

MVVSD0500R_-84
 MVVSD0600R_-84
 MVVSD0700R_-84
 MVVSD0800R_-84
 MVVSD0900R_-84

T = YT UNITS
 K = YK UNITS

NO	DRAWING NO	REV	DRAWING DESCRIPTION
00	I808JC00	9	MEDIUM VOLTAGE FLOOR MOUNT VFD
01	---	--	----
02	---	--	----
03	I808JC03	0	GROUNDING PROCEDURE
04	---	--	----
05	I808JC05	4	RATING SHEET
06	---	--	----
07	I808JC07	2	ONE-LINE DIAGRAM
08	---	--	----
09	---	--	----
10	I808JC10	2	THREE-LINE DIAGRAM
11	I808JC11	3	MAIN CIRCUIT
12	I808JC12	1	RECTIFIER CIRCUIT
13	---	--	----
14	---	--	----
15	I808JC15	2	CONTROL POWER AND FAN CIRCUITS

NO	DRAWING NO	REV	DRAWING DESCRIPTION
16	I808JC16	2	PCB INTERCONNECTION (1)
17	I808JC17	1	PCB INTERCONNECTION (2)
18	I808JC18	1	EXTERNAL I/O (1)
19	I808JC19	1	EXTERNAL I/O (2)
20	I808JC20	2	CONTROL CIRCUIT
21	---	--	----
22	---	--	----
23	---	--	----
24	---	--	----
25	---	--	----
26	---	--	----
27	---	--	----
28	I808JC28	2	CHILLER SYSTEM TERMINAL CONNECTIONS
29	---	--	----
30	I808JC30	1	ENCLOSURE OUTLINE
31	---	--	----

REV. LEV.	DATE	REVISION RECORD	CHG. NO.	DR.	CK.	REV. LEV.	DATE	REVISION RECORD	CHG. NO.	DR.	CK.	REV. LEV.	DATE	REVISION RECORD	CHG. NO.	DR.	CK.
6	10/24/11	REVISED 5		XZ	AL	13						20					
5	06/23/11	REVISED 5,7,11		XZ	AL	12						19					
4	07/22/10	REVISED		XZ	AL	11						18					
3	11/05/09	REVISED SHEET 5,15,16		XZ	AL	10						17					
2	05/22/08	REVISED		OB	AL	9	11/22/15	REVISED SHT 20			JO	AL	16				
1	10/15/08	REVISED		OB	AL	8	06/06/14	UPGRADED TO ACE FORMAT			JO	AL	15				
0	06/17/06	FIRST ISSUE		OB	AL	7	08/16/13	SHT 11			JO	AL	14				

YORK INTERNATIONAL CORPORATION
 YORK, PA .17405

DIMENSIONS ARE IN INCHES DO NOT SCALE TOLERANCES PER ENG. STD. M-282 WELDING PER ENG. STD. M-30 REF. DWG.		MEDIUM VOLTAGE VFD FLOOR MOUNT FRAME 0 4160V		MATERIAL TYPE _____ ENG. STD. _____ PART NO. _____ CUT SIZE _____	
DR. _____	DATE _____	SIZE D	CAGE NO _____	DRAWING NUMBER I808JC00	
APPR. _____	SCALE _____	WT. = _____	LBS. _____	ORIG. NO. _____	SHEET 1 of 15

ALL PROPRIETARY RIGHTS IN THE SUBJECT MATTER HEREOF ARE RESERVED, AND NO PERMISSION IS GRANTED TO REPRODUCE THIS PRINT IN WHOLE OR IN PART, OR DISCLOSE ANY OF THE INFORMATION UPON IT TO OTHERS WITHOUT WRITTEN RELEASE BY YORK INTERNATIONAL CORPORATION.

STANDARD PANEL GROUNDING PROCEDURES
TO BE FOLLOWED AT INSTALLATION

SCOPE

THIS DRAWING WILL DOCUMENT PROCEDURES WHICH ARE TO BE FOLLOWED BY CUSTOMER'S CONTRACTOR WHEN INSTALLING INDUSTRIAL DRIVE AND MOTOR SYSTEMS

IN ORDER TO UNDERSTAND THE REASONS FOR MANY OF THE PRACTICES THAT ARE RECOMMENDED, IT IS HELPFUL TO SEGREGATE THESE PRACTICES INTO TWO CATEGORIES AS FOLLOWS:

1) THOSE GENERALLY REFERRED TO AS EQUIPMENT GROUNDING PRACTICES WHOSE PURPOSES ARE:

- TO PROTECT AGAINST THE RISK OF ELECTRICAL SHOCK OR BURN.
- TO PROTECT THE EQUIPMENT FROM FIRE OR OTHER DAMAGE DUE TO GROUND FAULTS OR LIGHTNING STRIKES.

THESE PRACTICES WOULD TYPICALLY BE FOLLOWED BY THE CONTRACTOR IN COMPLIANCE WITH NEC OR OTHER CODE REQUIREMENTS.

2) THOSE PRACTICES WHICH MAKE THE EQUIPMENT IMMUNE TO ELECTRICAL NOISE ORIGINATING WITHIN OR OUTSIDE THE EQUIPMENT. THESE COMPLEMENT THE EQUIPMENT GROUNDING AND LEVEL WIRING PRACTICES IN PROVIDING NOISE IMMUNITY.

EQUIPMENT GROUNDING

- 1) ALL METAL BUILDING STRUCTURES SUCH AS COLUMNS, FLOOR BEAMS, ETC. SHOULD BE GROUNDED BY AN INTERCONNECTING HEAVY GROUND CABLE (5) IN ACCORDANCE WITH RECOMMENDED BUILDING PRACTICES AND LOCAL CODES.
- 2) ALL ELECTRICAL JOINTS AND CONNECTIONS TO THE BUILDING STRUCTURES SHOULD BE BRAZED OR EXOTHERMIC WELDED TO ASSURE THAT THE REQUIRED GOOD ELECTRICAL AND MECHANICAL PROPERTIES DO NOT DETERIORATE WITH THE PASSAGE OF TIME.
- 3) ALL PANELS SHOULD BE GROUNDED AT LEAST ONE POINT USING A HEAVY SAFETY CABLE (7). PANELS GREATER THAN 15 FT LONG SHOULD BE GROUNDED AT BOTH ENDS. THE GROUND CABLE NEEDS TO BE AT LEAST 1/0 AWG FOR MECHANICAL REASONS AND NEED NOT BE GREATER THAN 500 MCM. THIS CABLE IS USUALLY NON-INSULATED.
- 4) THE SAFETY GROUND CABLE (7) SHOULD BE BRAZED OR EXOTHERMIC WELDED (7A) TO A BUILDING STEEL STRUCTURE THAT IS CLOSEST TO THE PANEL, PREFERABLY WITHIN 25 FT.
- 5) THE EQUIPMENT END (7B) SHOULD BE BOLTED OR BRAZED TO A GROUND TERMINATION POINT ON THE PANEL.
- 6) THE EQUIPMENT GROUNDING TERMINAL IS A COPPER GROUND BUS OR STUB BUS BONDED TO THE PANEL ENCLOSURE USING BRAZING OR BOLTING IN SUCH MANNER THAT THE CONDUCTING PATH HAS A RESISTANCE OF 0.1 OHMS OR LESS.
- 7) THE GROUNDING CONDUCTORS MUST BE CAPABLE OF HANDLING ANTICIPATED GROUND FAULT CURRENTS.
- 8) THERE SHOULD BE A JUMPER CABLE (11) ACROSS THE GROUND BUS FLOOR SILL BETWEEN ANY SHIPPING SPLITS AND SIZED THE SAME AS THE SAFETY GROUND UNLESS OTHERWISE SPECIFIED.
- 9) THE PROTECTIVE GROUNDING DESCRIBED ABOVE FOR POWER CONVERSION AND CONTROL CABINETS IS ALSO NEEDED FOR MOTORS, TRANSFORMERS AND REACTORS. EACH OF THESE SHOULD HAVE ITS OWN GROUNDING CONDUCTOR GOING DIRECTLY TO THE BUILDING GROUND GRID.

GROUNDING PROCEDURES NEEDED TO ENSURE ELECTRICAL NOISE IMMUNITY

- 1) LEVELING BEAMS, STEEL MESH, GALVANIZED FLOOR, DECKING, ETC. SHOULD BE INSTALLED PRIOR TO PLACING THE EQUIPMENT. THESE SHOULD BE CONNECTED TO THE BUILDING GROUND SYSTEM USING A BRAZING OR EXOTHERMIC WELDING PROCESS.
- 2) GROUNDING LEVELING BEAMS ARE NOT AN ABSOLUTE NECESSITY FOR SATISFACTORY OPERATION. ON NEW CONSTRUCTION SUCH BEAMS CAN BE PROVIDED WITH LITTLE DIFFICULTY. FOR EXISTING CONSTRUCTION IT USUALLY WILL BE MORE DIFFICULT, IN WHICH CASE THE LEVELING BEAMS MAY BE DISPENSED WITH, PROVIDED OTHER GROUNDED STRUCTURES SUCH AS COLUMNS AND FLOOR BEAMS ARE WITHIN 10 FEET OF THE EQUIPMENT.
- 3) AFTER SETTING THE CONTROL PANELS IN PLACE, THE PERIPHERY OF THE CONTROL PANELS SHOULD BE SPOT WELDED TO THE STEEL CHANNELS APPROXIMATELY EVERY 18 INCHES. THIS CREATES A VERY GOOD HIGH FREQUENCY GROUND PLANE. CARE SHOULD BE TAKEN TO AVOID ELECTRONIC COMPONENT DAMAGE DURING THE WELDING PROCESS BY KEEPING THE WELDED RETURN PATH AS CLOSE AS POSSIBLE TO THE WORK POSITION. THAT IS, THE RETURN PATH SHOULD ALWAYS BE WITHIN 3 FEET OF THE ELECTRODE.
- 4) IF LEVELING BEAMS ARE NOT INSTALLED, A NUMBER OF GROUNDING CABLES (7C) SHOULD BE RUN FROM THE GROUND LUGS PROVIDED ON THE PANEL TO THE NEAREST GROUNDED COLUMN OR FLOOR BEAM, OR WIRE FLOOR MESH, ETC. THIS WILL PROVIDE THE NECESSARY HIGH FREQUENCY GROUND PLANE.

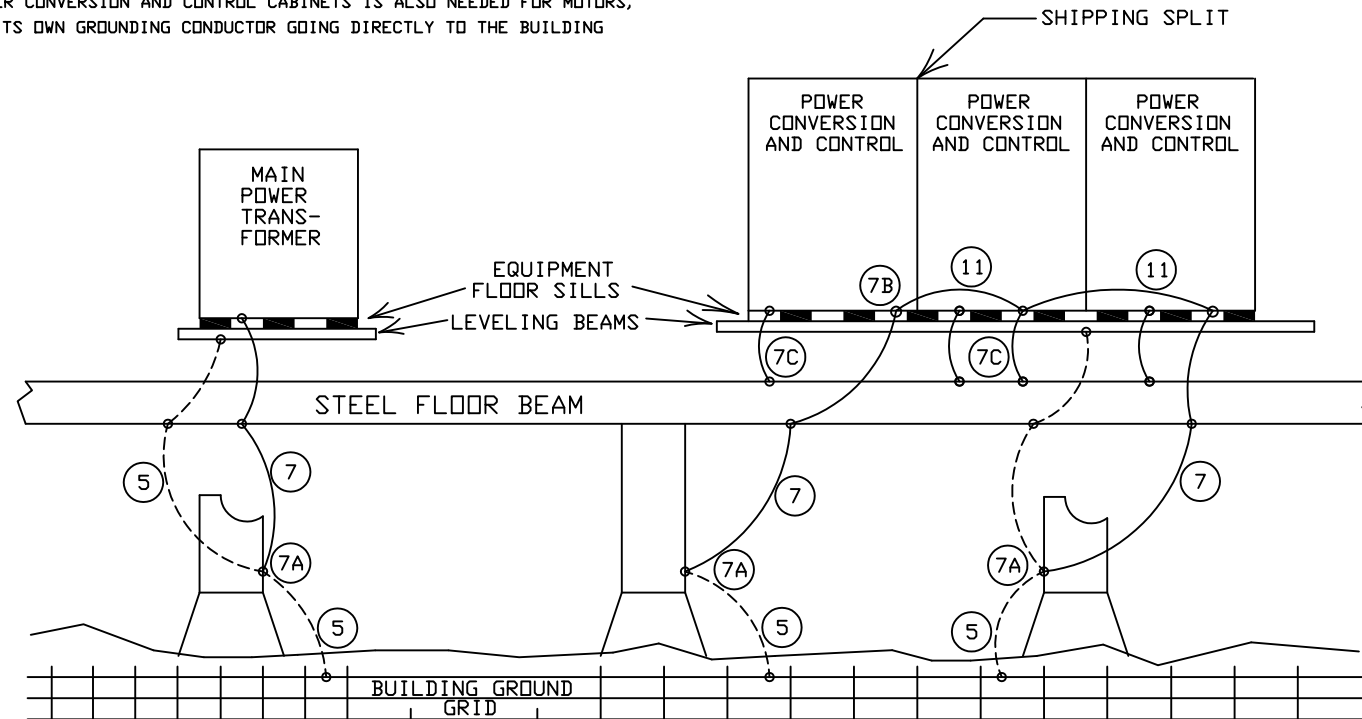

REV. LEV.	DATE	REVISION RECORD	CHG. NO.	DR.	CK.	REV. LEV.	DATE	REVISION RECORD	CHG. NO.	DR.	CK.	REV. LEV.	DATE	REVISION RECORD	CHG. NO.	DR.	CK.
6						13						20					
5						12						19					
4						11						18					
3						10						17					
2						9						16					
1						8						15					
0	06/17/06	FIRST ISSUE		OB	AL	7						14					

ALL PROPRIETARY RIGHTS IN THE SUBJECT MATTER HEREOF ARE RESERVED, AND NO PERMISSION IS GRANTED TO REPRODUCE THIS PRINT IN WHOLE OR IN PART, OR DISCLOSE ANY OF THE INFORMATION UPON IT TO OTHERS WITHOUT WRITTEN RELEASE BY YORK INTERNATIONAL CORPORATION.

YORK INTERNATIONAL CORPORATION YORK, PA .17405			
DIMENSIONS ARE IN INCHES DO NOT SCALE TOLERANCES PER ENG. STD. M-282 WELDING PER ENG. STD. M-30 REF. DWG.		GROUNDING PROCEDURE	MATERIAL TYPE _____ ENG. STD. _____ PART NO. _____ CUT SIZE _____
DR. _____ APPR. _____ SCALE: _____	NAME _____ DATE _____ SIZE D	CAGE NO. _____	DRAWING NUMBER 1808JC03
WT. = _____ LBS.	ORIG. NO. _____	SHEET 2 of 15	

COMPONENT RATING		
SHEET NUMBER	COMPONENT	MVSD0500R_-84 ~ 0900R_-84
		RATING
5	10LA	6kV
	10ISW1	360A, 6.6kV
	10FU1~3	SEE TABLE A
	10M1	360A, 6.6kV
	10M1A	360A, 6.6kV
	10ACL	40mH
	10F4~7	2E, 4.8kV
	10PT1~2	500VA, 4200:120V
	10CPT	SEE TABLE A
	10F8~10	3E, 4.8kV
	10F12~14	SEE TABLE A
	10F15	20A, 600Vac
	6	HCTU,HCTW
11T1		SEE TABLE A
11R11		100k ohm, 225W
GDI		---
11L1		SEE TABLE A
7	FUSE	SEE TABLE A
	DIODE	2200V, 160A
	POWER MODULE (U,V,W)	±1800Vdc, 124A
8	15MCB1	15A, 600V
	15V1	480V, 2a2b
	15MS1~2	1.6~2.5A, 480V (set @ 2.3A)
	15MOV1~3	625V, 230J
	15FN1~2	460V, 1.2kW
	15MCB2	240Vac, 20A, 2P
	15F1~2	5A, 600Vac
	PDM	---
	15PS1	120/240:+5,+/-15,24V,80W
	15DS1	10A, 600V
	VX	25A, 4a4b/2a2b, 120Vac
9	CTR	---
	GSD	---
	16R1,3	SEE TABLE A
	16R2,4	SEE TABLE A
	MODBUS	ETHERNET/RTU (RS485)
10	IPAD	---
	DISP	G7A
	XIO	---
11	BLR	24Vdc, 4a0b
	FLT,INPC	24Vdc, 2a2b
13	EXT	115V, 4a0b
	SS	50-129V AC/DC

MODEL NUMBER	MOTOR HP	DRIVE FLA	OIL PUMP TYPE	10FU1~3	10CPT	10F12~14	11T1	11L1	FUSE	16R1,3	16R2,4
				RATING	RATING	RATING	RATING	RATING	RATING	RATING	RATING
MVSD0500RT-84	500	62	YT	80E, 5.5KV	4160:460V-2KVA,115V-2KVA	5A, 600V	449kVA,4160V:635V(12)	100uH, 75A	700V, 100A	50 ohm, 3W, 1%	40 ohm, 3W, 1%
MVSD0500RK-84	500	62	YK	80E, 5.5KV	4160:460V-3KVA,115V-2KVA	7A, 600V	449kVA,4160V:635V(12)	100uH, 75A	700V, 100A	50 ohm, 3W, 1%	40 ohm, 3W, 1%
MVSD0600RT-84	600	74	YT	100E, 5.5KV	4160:460V-2KVA,115V-2KVA	5A, 600V	534kVA,4160V:635V(12)	100uH, 75A	700V, 100A	50 ohm, 3W, 1%	25 ohm, 3W, 1%
MVSD0600RK-84	600	74	YK	100E, 5.5KV	4160:460V-3KVA,115V-2KVA	7A, 600V	534kVA,4160V:635V(12)	100uH, 75A	700V, 100A	50 ohm, 3W, 1%	25 ohm, 3W, 1%
MVSD0700RT-84	700	87	YT	125E, 5.5KV	4160:460V-2KVA,115V-2KVA	5A, 600V	618kVA,4160V:635V(12)	100uH, 130A	700V, 125A	35 ohm, 3W, 1%	30 ohm, 3W, 1%
MVSD0700RK-84	700	87	YK	125E, 5.5KV	4160:460V-3KVA,115V-2KVA	7A, 600V	618kVA,4160V:635V(12)	100uH, 130A	700V, 125A	35 ohm, 3W, 1%	30 ohm, 3W, 1%
MVSD0800RT-84	800	99	YT	150E, 5.5KV	4160:460V-2KVA,115V-2KVA	5A, 600V	703kVA,4160V:635V(12)	100uH, 130A	700V, 125A	32 ohm, 3W, 1%	25 ohm, 3W, 1%
MVSD0800RK-84	800	99	YK	150E, 5.5KV	4160:460V-3KVA,115V-2KVA	7A, 600V	703kVA,4160V:635V(12)	100uH, 130A	700V, 125A	32 ohm, 3W, 1%	25 ohm, 3W, 1%
MVSD0900RT-84	900	112	YT	150E, 5.5KV	4160:460V-2KVA,115V-2KVA	5A, 600V	788kVA,4160V:635V(12)	100uH, 130A	700V, 150A	25 ohm, 3W, 1%	25 ohm, 3W, 1%
MVSD0900RK-84	900	112	YK	150E, 5.5KV	4160:460V-3KVA,115V-2KVA	7A, 600V	788kVA,4160V:635V(12)	100uH, 130A	700V, 150A	25 ohm, 3W, 1%	25 ohm, 3W, 1%

YORK INTERNATIONAL CORPORATION
YORK, PA . 17405

REV. LEV.	DATE	REVISION RECORD	CHG. NO.	DR.	CK.	REV. LEV.	DATE	REVISION RECORD	CHG. NO.	DR.	CK.	REV. LEV.	DATE	REVISION RECORD	CHG. NO.	DR.	CK.
6						13						20					
5						12						19					
4	06/06/14	UPGRADED TO ACE FORMAT		JO	AL	11						18					
3	10/24/11	REVISED 11L1		XZ	AL	10						17					
2	06/23/11	ADDED 11L1		XZ	AL	9						16					
1	11/05/09	REVISED SHEET 11,13		XZ	AL	8						15					
0	06/17/06	FIRST ISSUE		OB	AL	7						14					

ALL PROPRIETARY RIGHTS IN THE SUBJECT MATTER HEREOF ARE RESERVED, AND NO PERMISSION IS GRANTED TO REPRODUCE THIS PRINT IN WHOLE OR IN PART, OR DISCLOSE ANY OF THE INFORMATION UPON IT TO OTHERS WITHOUT WRITTEN RELEASE BY YORK INTERNATIONAL CORPORATION.

DIMENSIONS ARE IN INCHES
DO NOT SCALE
TOLERANCES PER ENG. STD. M-282
WELDING PER ENG. STD. M-30
REF. DWG.

RATING SHEET, COMPONENTS

MATERIAL
TYPE _____ ENG. STD. _____
PART NO. _____
CUT SIZE _____

DR. _____ DATE _____ SIZE _____ CAGE NO. _____ DRAWING NUMBER 1808JC05
APPR. _____
SCALE: _____

WT. = _____ LBS. ORIG. NO. _____ SHEET 3 of 15

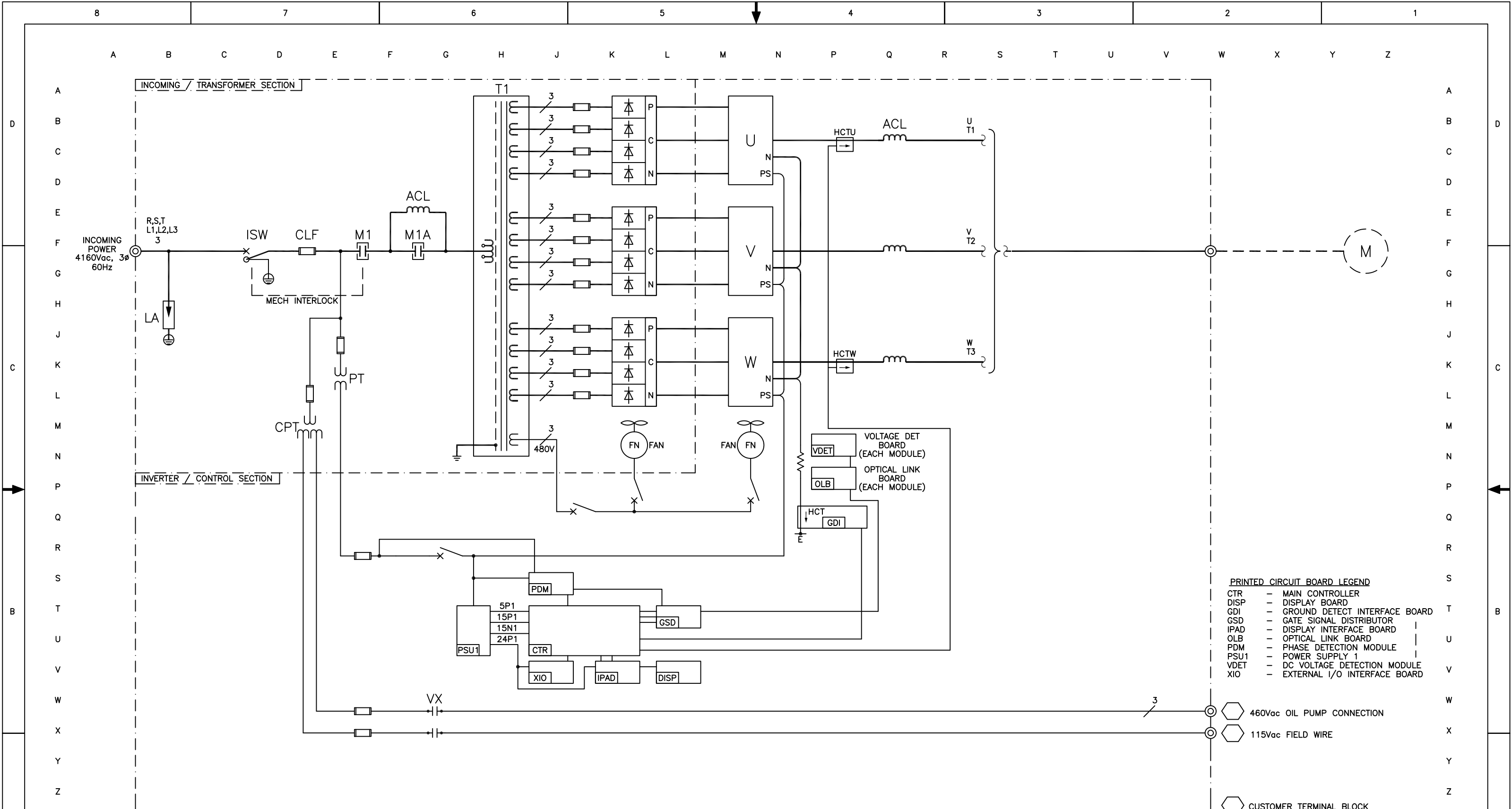

- PRINTED CIRCUIT BOARD LEGEND**
- CTR - MAIN CONTROLLER
 - DISP - DISPLAY BOARD
 - GDI - GROUND DETECT INTERFACE BOARD
 - GSD - GATE SIGNAL DISTRIBUTOR
 - IPAD - DISPLAY INTERFACE BOARD
 - OLB - OPTICAL LINK BOARD
 - PDM - PHASE DETECTION MODULE
 - PSU1 - POWER SUPPLY 1
 - VDET - DC VOLTAGE DETECTION MODULE
 - XIO - EXTERNAL I/O INTERFACE BOARD

- 460Vac OIL PUMP CONNECTION
- 115Vac FIELD WIRE
- CUSTOMER TERMINAL BLOCK

YORK INTERNATIONAL CORPORATION
YORK, PA .17405

DIMENSIONS ARE IN INCHES DO NOT SCALE TOLERANCES PER ENG. STD. M-282 WELDING PER ENG. STD. M-30 REF. DWG.		ONE-LINE DIAGRAM		MATERIAL TYPE _____ ENG. STD. _____ PART NO. _____ CUT SIZE _____	
DR. _____	DATE _____	SIZE D	CAGE NO. _____	DRAWING NUMBER 1808JC07	
APPR. _____	SCALE: _____	WT. = _____	LBS. _____	ORIG. NO. _____	SHEET 4 of 15

REV. LEV.	DATE	REVISION RECORD	CHG. NO.	DR.	CK.	REV. LEV.	DATE	REVISION RECORD	CHG. NO.	DR.	CK.	REV. LEV.	DATE	REVISION RECORD	CHG. NO.	DR.	CK.
6						13						20					
5						12						19					
4						11						18					
3						10						17					
2	06/06/14	UPGRADED TO ACE FORMAT				9						16					
1	06/23/11	ADDED ACL				8						15					
0	06/17/06	FIRST ISSUE				7						14					

"ALL PROPRIETARY RIGHTS IN THE SUBJECT MATTER HEREOF ARE RESERVED, AND NO PERMISSION IS GRANTED TO REPRODUCE THIS PRINT IN WHOLE OR IN PART, OR DISCLOSE ANY OF THE INFORMATION UPON IT TO OTHERS WITHOUT WRITTEN RELEASE BY YORK INTERNATIONAL CORPORATION."

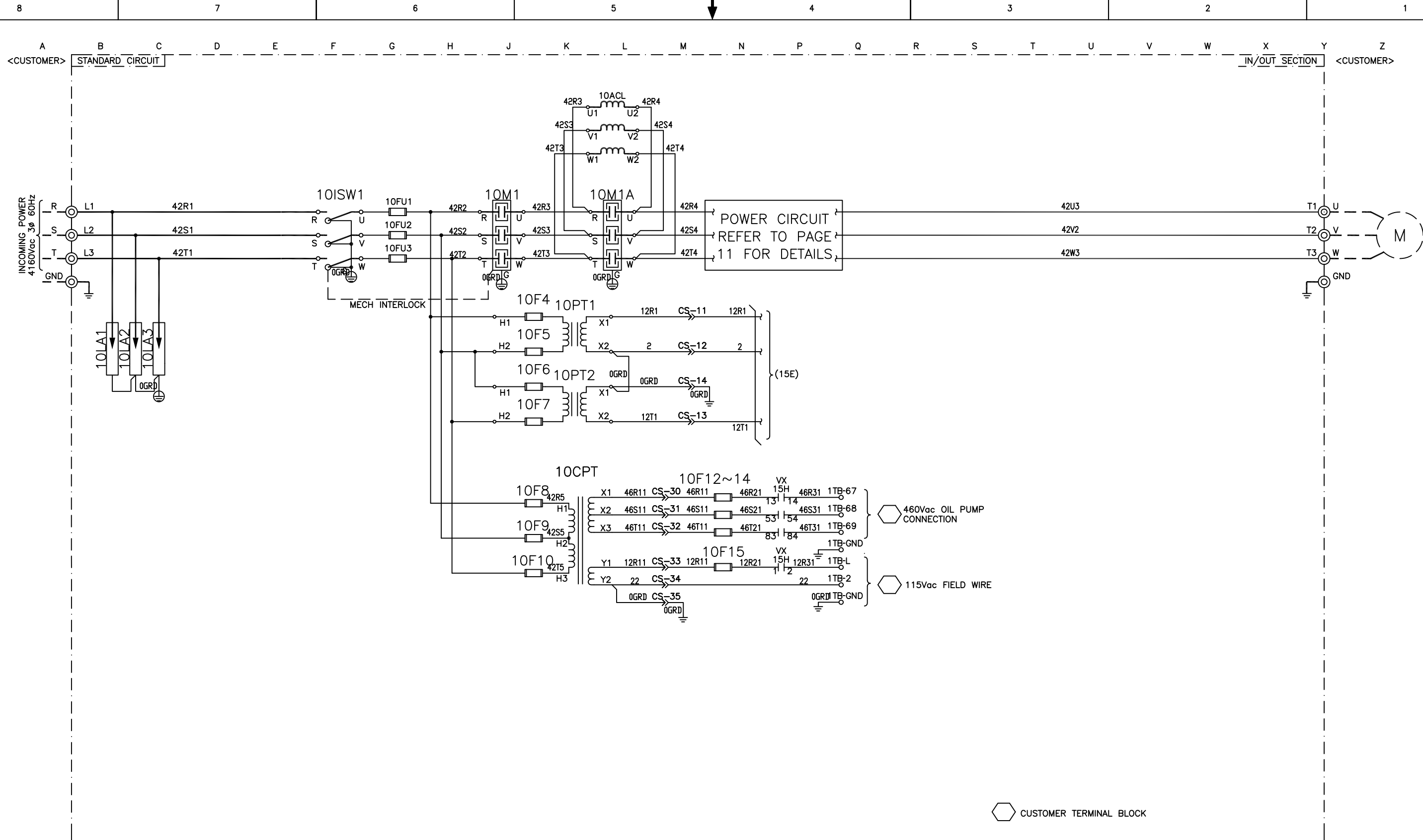

CUSTOMER TERMINAL BLOCK

CUSTOMER TERMINAL BLOCK

YORK INTERNATIONAL CORPORATION
YORK, PA . 17405

DIMENSIONS ARE IN INCHES DO NOT SCALE TOLERANCES PER ENG. STD. M-282 WELDING PER ENG. STD. M-30 REF. DWG.		THREE-LINE DIAGRAM		MATERIAL TYPE _____ ENG. STD. _____ PART NO. _____ CUT SIZE _____	
DR. _____	NAME _____	DATE _____	SIZE D	CAGE NO. _____	DRAWING NUMBER 1808JC10
SCALE: _____			WT. = _____	LBS. _____	ORIG. NO. _____

SHEET 5 of 15

REV. LEV.	DATE	REVISION RECORD	CHG. NO.	DR.	CK.	REV. LEV.	DATE	REVISION RECORD	CHG. NO.	DR.	CK.	REV. LEV.	DATE	REVISION RECORD	CHG. NO.	DR.	CK.
6						13						20					
5						12						19					
4						11						18					
3						10						17					
2	06/06/14	UPGRADED TO ACE FORMAT		JO	AL	9						16					
1	05/22/08	ADDED CS-35		OB	AL	8						15					
0	06/17/06	FIRST ISSUE		OB	AL	7						14					

*ALL PROPRIETARY RIGHTS
IN THE SUBJECT MATTER
HEREOF ARE RESERVED,
AND NO PERMISSION IS
GRANTED TO REPRODUCE
THIS PRINT IN WHOLE
OR IN PART, OR DISCLOSE
ANY OF THE INFORMATION
UPON IT TO OTHERS
WITHOUT WRITTEN RELEASE
BY YORK INTERNATIONAL
CORPORATION.*

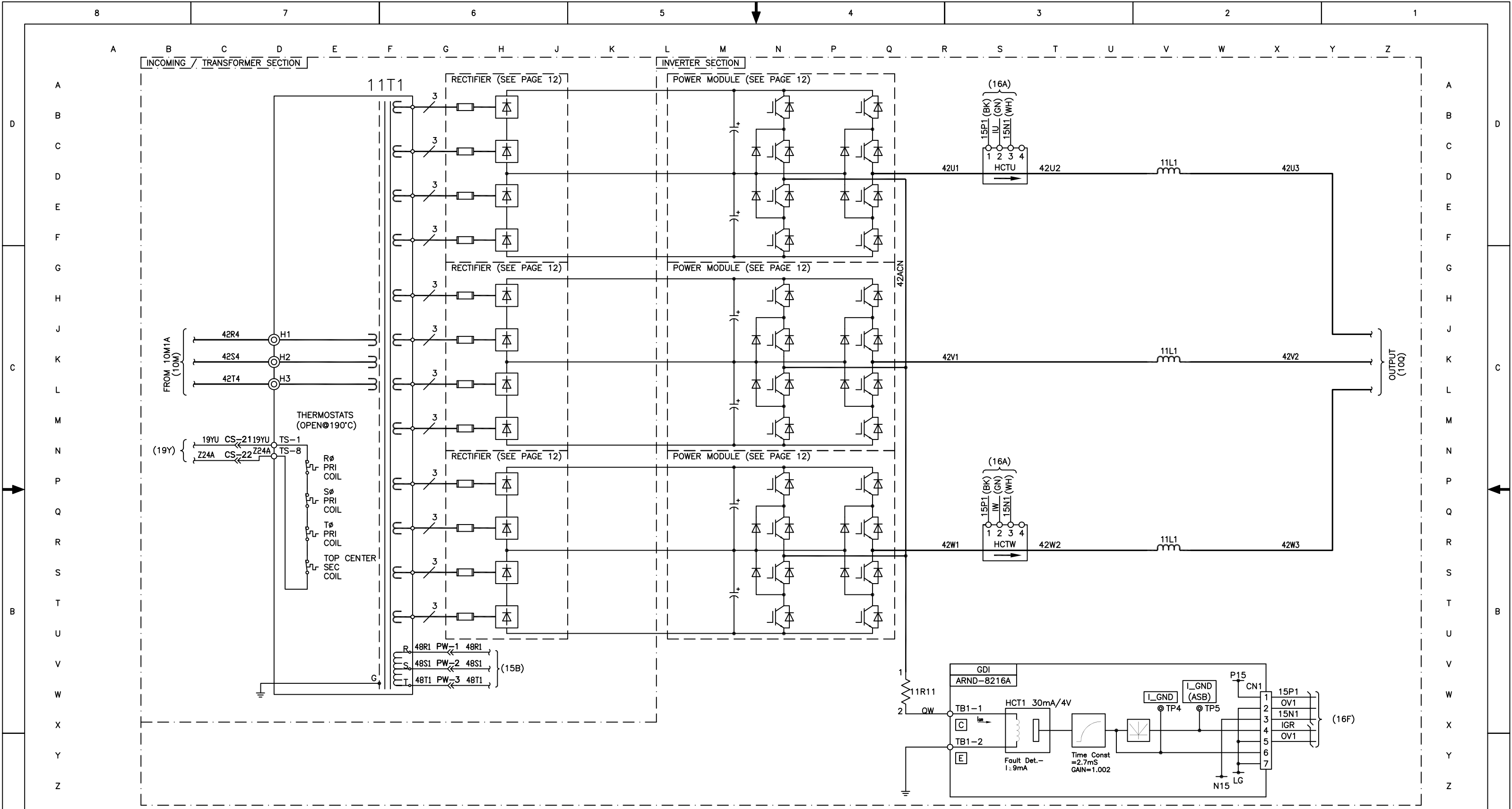

YORK INTERNATIONAL CORPORATION YORK, PA . 17405																				
REVISION RECORD						REVISION RECORD						REVISION RECORD								
REV. LEV.	DATE	CHG. NO.	DR.	CK.	REV. LEV.	DATE	CHG. NO.	DR.	CK.	REV. LEV.	DATE	CHG. NO.	DR.	CK.	REV. LEV.	DATE	CHG. NO.	DR.	CK.	
6					13					20										
5					12					19										
4					11					18										
3	06/06/74		JO	AL	10					17										
2	08/16/73		JO	AL	9					16										
1	06/23/71		XZ	AL	8					15										
0	06/17/66		OB	AL	7					14										

DIMENSIONS ARE IN INCHES DO NOT SCALE TOLERANCES PER ENG. STD. M-282 WELDING PER ENG. STD. M-30 REF. DWG.												MAIN CIRCUIT						MATERIAL TYPE _____ ENG. STD. _____ PART NO. _____ CUT SIZE _____					
NAME _____ DATE _____			SIZE D			CAGE NO. _____			DRAWING NUMBER 1808JC11														
DR. APPR. _____ SCALE: _____												WT. = _____ LBS.			ORIG. NO. _____			SHEET 6 of 15					

*ALL PROPRIETARY RIGHTS
 IN THE SUBJECT MATTER
 HEREOF ARE RESERVED,
 AND NO PERMISSION IS
 GRANTED TO REPRODUCE
 THIS PRINT IN WHOLE
 OR IN PART, OR DISCLOSE
 ANY OF THE INFORMATION
 UPON IT TO OTHERS
 WITHOUT WRITTEN RELEASE
 BY YORK INTERNATIONAL
 CORPORATION.

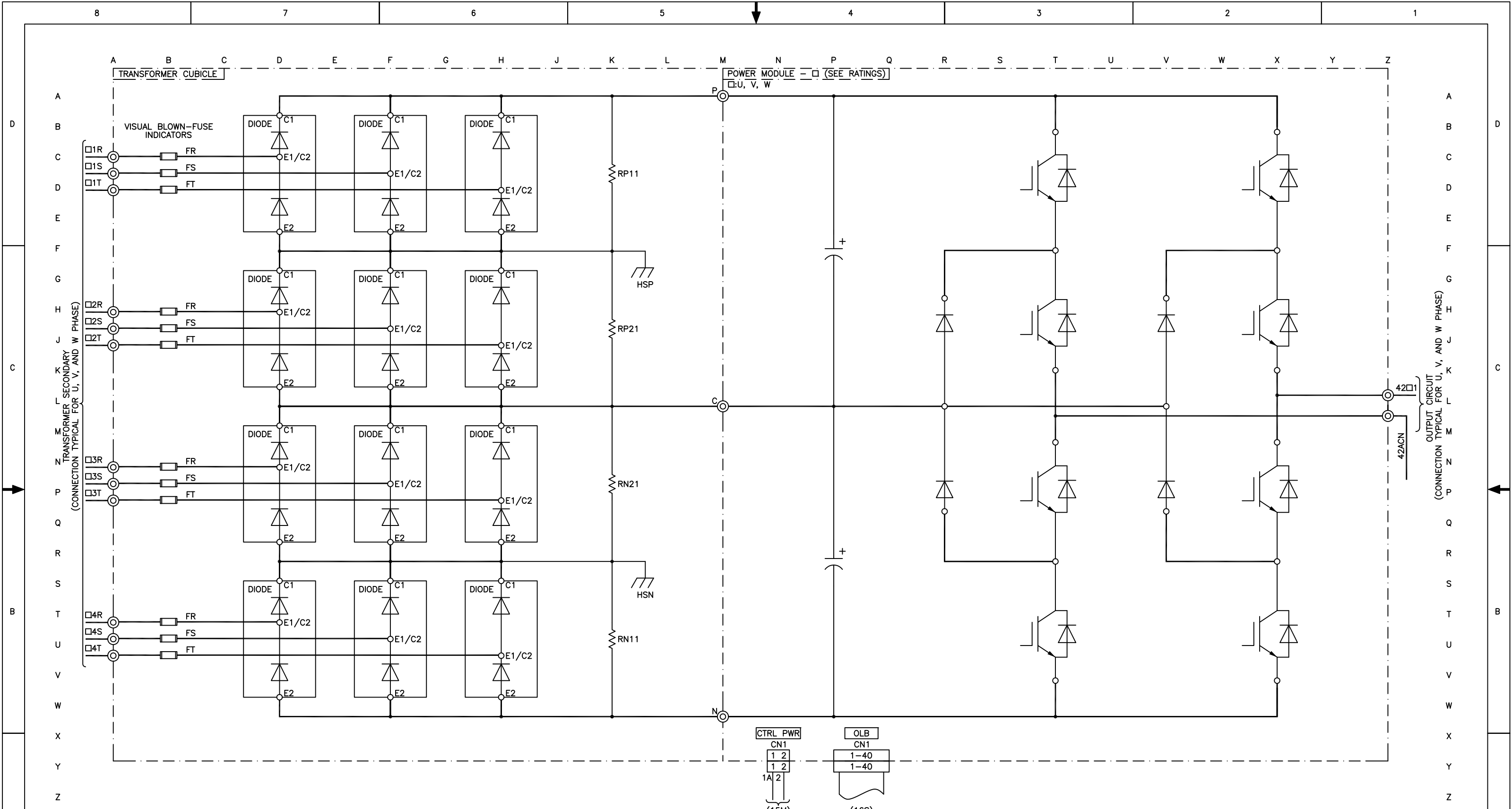

YORK INTERNATIONAL CORPORATION YORK, PA . 17405																				
REVISION RECORD				REVISION RECORD				REVISION RECORD				REVISION RECORD								
REV. LEV.	DATE	CHG. NO.	DR.	CK.	REV. LEV.	DATE	CHG. NO.	DR.	CK.	REV. LEV.	DATE	CHG. NO.	DR.	CK.	REV. LEV.	DATE	CHG. NO.	DR.	CK.	
6					13					20										
5					12					19										
4					11					18										
3					10					17										
2					9					16										
1	06/06/14		UPGRADED TO ACE FORMAT		8					15										
0	06/17/06		FIRST ISSUE		7					14										

DR. _____ DATE _____ SIZE _____ CAGE NO. _____ DRAWING NUMBER 1808JC12

APPR. _____ SCALE: _____ WT. = _____ LBS. ORG. NO. _____ SHEET 7 of 15

DIMENSIONS ARE IN INCHES
DO NOT SCALE
TOLERANCES PER ENG. STD. M-282
WELDING PER ENG. STD. M-30
REF. DWG.

RECTIFIER CKT.
(ONE PHASE)

MATERIAL
TYPE _____ ENG. STD. _____
PART NO. _____
CUT SIZE _____

ALL PROPRIETARY RIGHTS IN THE SUBJECT MATTER HEREOF ARE RESERVED, AND NO PERMISSION IS GRANTED TO REPRODUCE THIS PRINT IN WHOLE OR IN PART, OR DISCLOSE ANY OF THE INFORMATION UPON IT TO OTHERS WITHOUT WRITTEN RELEASE BY YORK INTERNATIONAL CORPORATION.

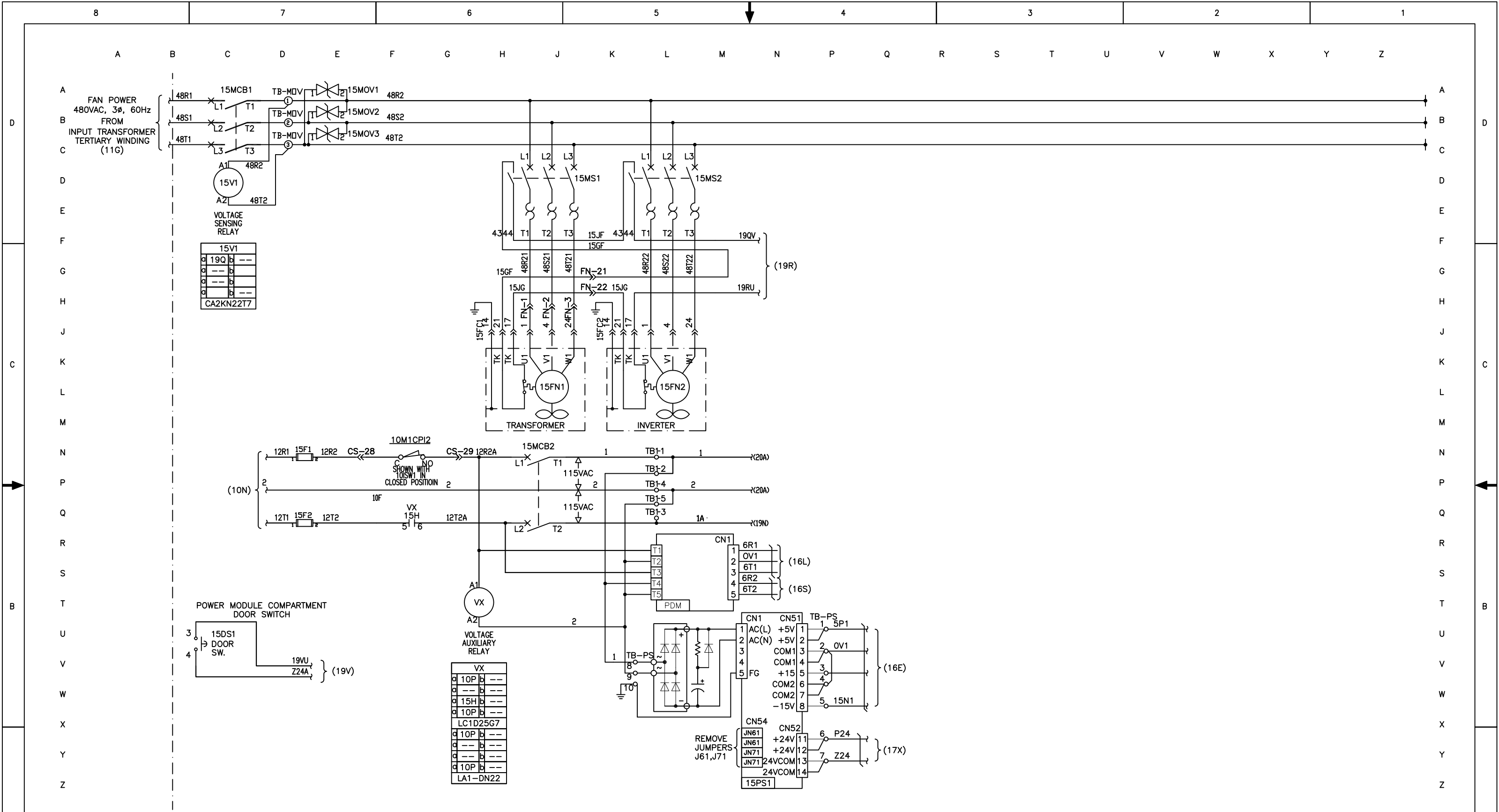

YORK INTERNATIONAL CORPORATION YORK, PA .17405											
CONTROL POWER AND FANS CIRCUIT											
DIMENSIONS ARE IN INCHES DO NOT SCALE TOLERANCES PER ENG. STD. M-282 WELDING PER ENG. STD. M-30 REF. DWG.											
MATERIAL TYPE _____ ENG. STD. _____ PART NO. _____ CUT SIZE _____											
NAME _____ DATE _____			SIZE D		CAGE NO _____		DRAWING NUMBER 1808JC15				
DR. APPR. _____			WT. = _____ LBS.		ORIG. NO. _____		SHEET 8 of 15				

REV. LEV.	DATE	REVISION RECORD	CHG. NO.	DR.	CK.	REV. LEV.	DATE	REVISION RECORD	CHG. NO.	DR.	CK.	REV. LEV.	DATE	REVISION RECORD	CHG. NO.	DR.	CK.
6						13						20					
5						12						19					
4						11						18					
3						10						17					
2	06/06/14	UPGRADED TO ACE FORMAT			AL	9						16					
1	11/05/09	REVISED TB-PS			XZ	8						15					
0	06/17/06	FIRST ISSUE			OB	7						14					

ALL PROPRIETARY RIGHTS IN THE SUBJECT MATTER HEREOF ARE RESERVED, AND NO PERMISSION IS GRANTED TO REPRODUCE THIS PRINT IN WHOLE OR IN PART, OR DISCLOSE ANY OF THE INFORMATION UPON IT TO OTHERS WITHOUT WRITTEN RELEASE BY YORK INTERNATIONAL CORPORATION.

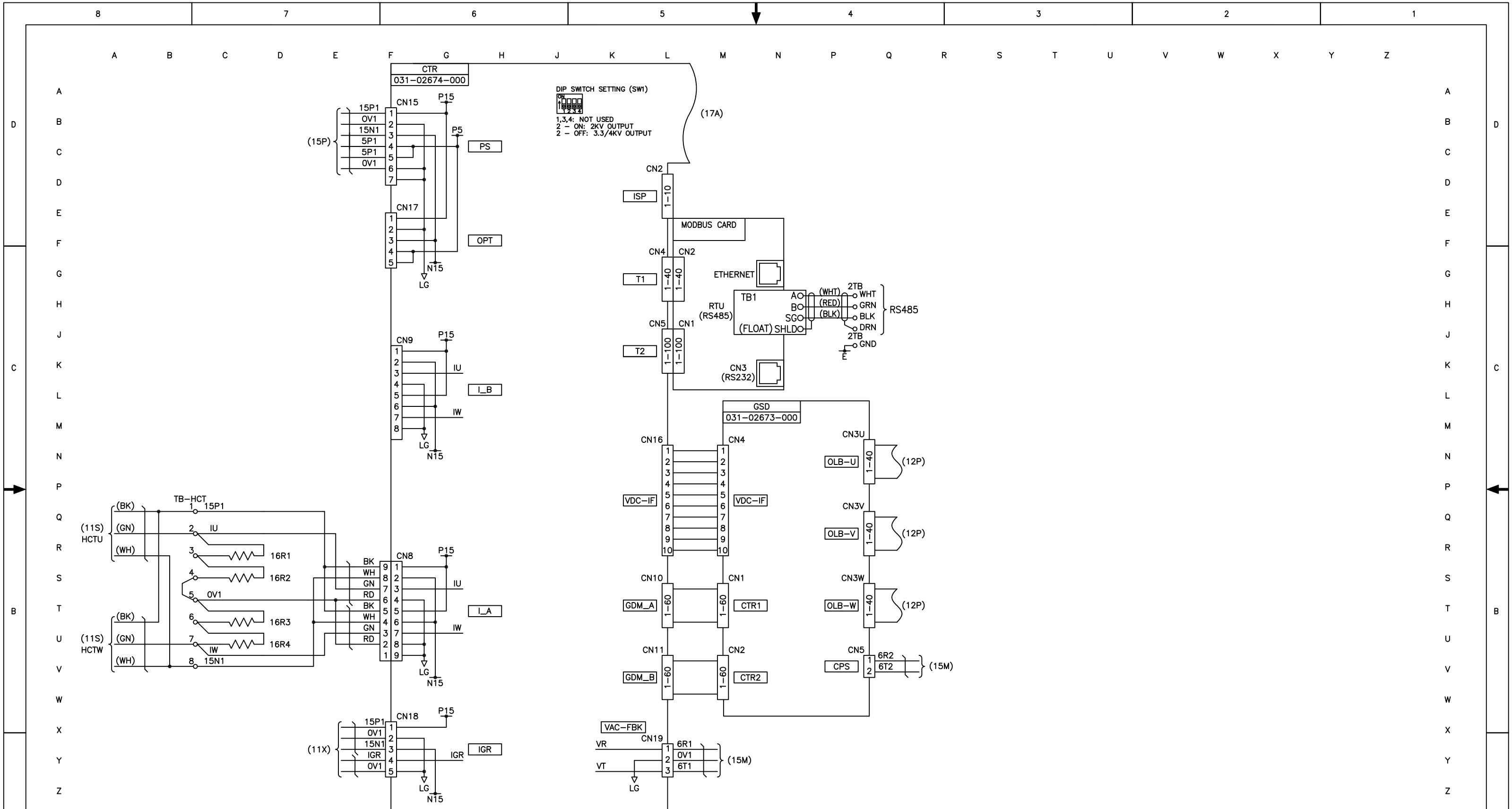

YORK INTERNATIONAL CORPORATION
YORK, PA . 17405

DIMENSIONS ARE IN INCHES DO NOT SCALE TOLERANCES PER ENG. STD. M-282 WELDING PER ENG. STD. M-30 REF. DWG.		PCB (1) INTERCONNECTION		MATERIAL TYPE _____ ENG. STD. _____ PART NO. _____ CUT SIZE _____
DR. _____	DATE _____	SIZE D	CAGE NO. _____	DRAWING NUMBER 1808JC16
APPR. _____	SCALE: _____	WT. = _____ LBS.	ORIG. NO. _____	SHEET 9 of 15

REV. LEV.	DATE	REVISION RECORD	CHG. NO.	DR.	CK.	REV. LEV.	DATE	REVISION RECORD	CHG. NO.	DR.	CK.	REV. LEV.	DATE	REVISION RECORD	CHG. NO.	DR.	CK.
6						13						20					
5						12						19					
4						11						18					
3						10						17					
2	06/06/14	UPGRADED TO ACE FORMAT		JO	AL	9						16					
1	02/05/08	REMOVED 2TB JUMPER & RES		OB	AL	8						15					
0	05/17/06	FIRST ISSUE		OB	AL	7						14					

*ALL PROPRIETARY RIGHTS
IN THE SUBJECT MATTER
HEREOF ARE RESERVED,
AND NO PERMISSION IS
GRANTED TO REPRODUCE
THIS PRINT IN WHOLE
OR IN PART, OR DISCLOSE
ANY OF THE INFORMATION
UPON IT TO OTHERS
WITHOUT WRITTEN RELEASE
BY YORK INTERNATIONAL
CORPORATION.

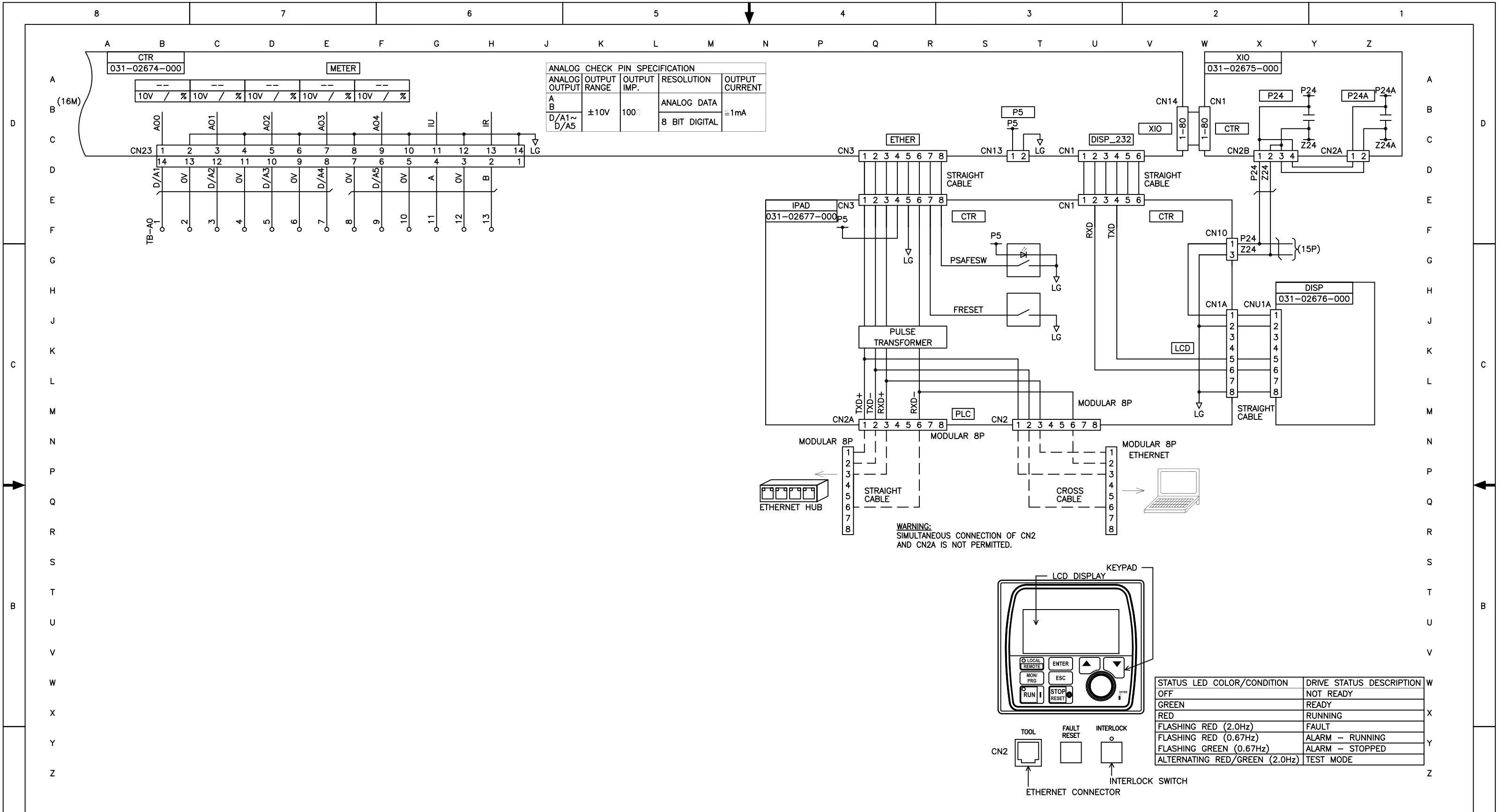

ANALOG CHECK PIN SPECIFICATION				
ANALOG OUTPUT	OUTPUT RANGE	OUTPUT IMP.	RESOLUTION	OUTPUT CURRENT
A	±10V	100Ω	ANALOG DATA	±1mA
B			8 BIT DIGITAL	

STATUS LED COLOR/CONDITION	DRIVE STATUS DESCRIPTION
OFF	NOT READY
GREEN	READY
RED	RUNNING
FLASHING RED (2.0Hz)	FAULT
FLASHING RED (0.67Hz)	ALARM - RUNNING
FLASHING GREEN (0.67Hz)	ALARM - STOPPED
ALTERNATING RED/GREEN (2.0Hz)	TEST MODE

REV. LEV.	DATE	REVISION RECORD	CHG. NO.	DR.	CK.	REV. LEV.	DATE	REVISION RECORD	CHG. NO.	DR.	CK.	REV. LEV.	DATE	REVISION RECORD	CHG. NO.	DR.	CK.
6						13						20					
5						12						19					
4						11						18					
3						10						17					
2						9						16					
1	06/06/14	UPGRADED TO ACE FORMAT		JO	AL	8						15					
0	05/17/06	FIRST ISSUE		OB	AL	7						14					

YORK INTERNATIONAL CORPORATION
YORK, PA . 17405

**PCB (2)
INTERCONNECTION**

MATERIAL
TYPE _____ ENG. STD. _____
PART NO. _____
CUT SIZE _____

DR. _____ DATE _____ SIZE D CAGE NO. _____ DRAWING NUMBER 1808JC17
APPR. _____ SCALE: _____ WT. = _____ LBS. ORIG. NO. _____ SHEET 10 of 15

*ALL PROPRIETARY RIGHTS IN THE SUBJECT MATTER HEREOF ARE RESERVED, AND NO PERMISSION IS GRANTED TO REPRODUCE THIS PRINT IN WHOLE OR IN PART, OR DISCLOSE ANY OF THE INFORMATION UPON IT TO OTHERS WITHOUT WRITTEN RELEASE BY YORK INTERNATIONAL CORPORATION.

XIO JUMPER SETTINGS			
JUMPER	EXPLANATION	SILKSCREEN	SETTING
JP3	Pulse Generator (PG) power supply level selection. "P15" = +15VDC power supply "P5" = +5VDC power supply	PT5	1-2
		P5	2-3
		PT	2-3
JP4	Motor temperature sensor type selection. External transducer required when using 100 ohm sensor. "PT" = 1k ohm platinum motor temperature sensor "RTD" = 100 ohm platinum motor temperature sensor	PT	2-3
		RTD	1-2

FLT		INPC		BLR	
a	20Y	b	---	a	20D
b	---	b	---	b	---
c	---	b	---	c	20C
d	---	b	---	d	---
CA44KN22BW3		CA44KN22BW3		CA44KN40BW3	
VFD FAULT		INPUT CONT CLOSE/OPEN		AC TRIP	

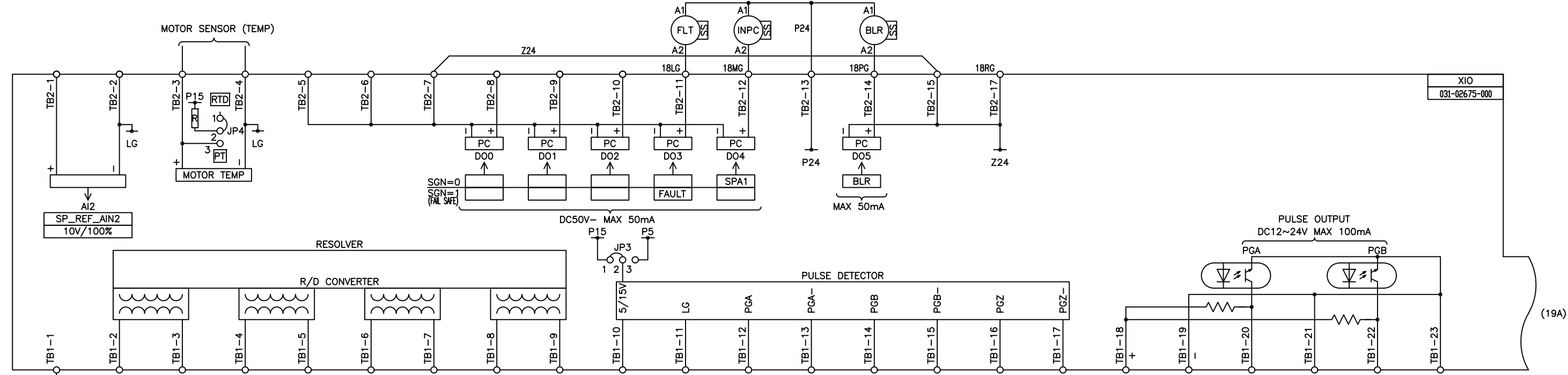

REV. LEV.	DATE	REVISION RECORD	CHG. NO.	DR.	CK.	REV. LEV.	DATE	REVISION RECORD	CHG. NO.	DR.	CK.	REV. LEV.	DATE	REVISION RECORD	CHG. NO.	DR.	CK.
6						13						20					
5						12						19					
4						11						18					
3						10						17					
2						9						16					
1	06/06/14	UPGRADED TO ACE FORMAT		JO	AL	8						15					
0	06/17/06	FIRST ISSUE		OB	AL	7						14					

ALL PROPRIETARY RIGHTS IN THE SUBJECT MATTER HEREOF ARE RESERVED, AND NO PERMISSION IS GRANTED TO REPRODUCE THIS PRINT IN WHOLE OR IN PART, OR DISCLOSE ANY OF THE INFORMATION UPON IT TO OTHERS WITHOUT WRITTEN RELEASE BY YORK INTERNATIONAL CORPORATION.

YORK INTERNATIONAL CORPORATION
YORK, PA .17405

EXTERNAL I/O (1)

DIMENSIONS ARE IN INCHES
DO NOT SCALE
TOLERANCES PER ENG. STD. M-282
WELDING PER ENG. STD. M-30
REF. DWG.

MATERIAL
TYPE _____ ENG. STD. _____
PART NO. _____
CUT SIZE _____

DR. _____ DATE _____ SIZE D CAGE NO. _____ DRAWING NUMBER 1808JC18
APPR. _____
SCALE: _____

WT. = _____ LBS. ORG. NO. _____ SHEET 11 of 15

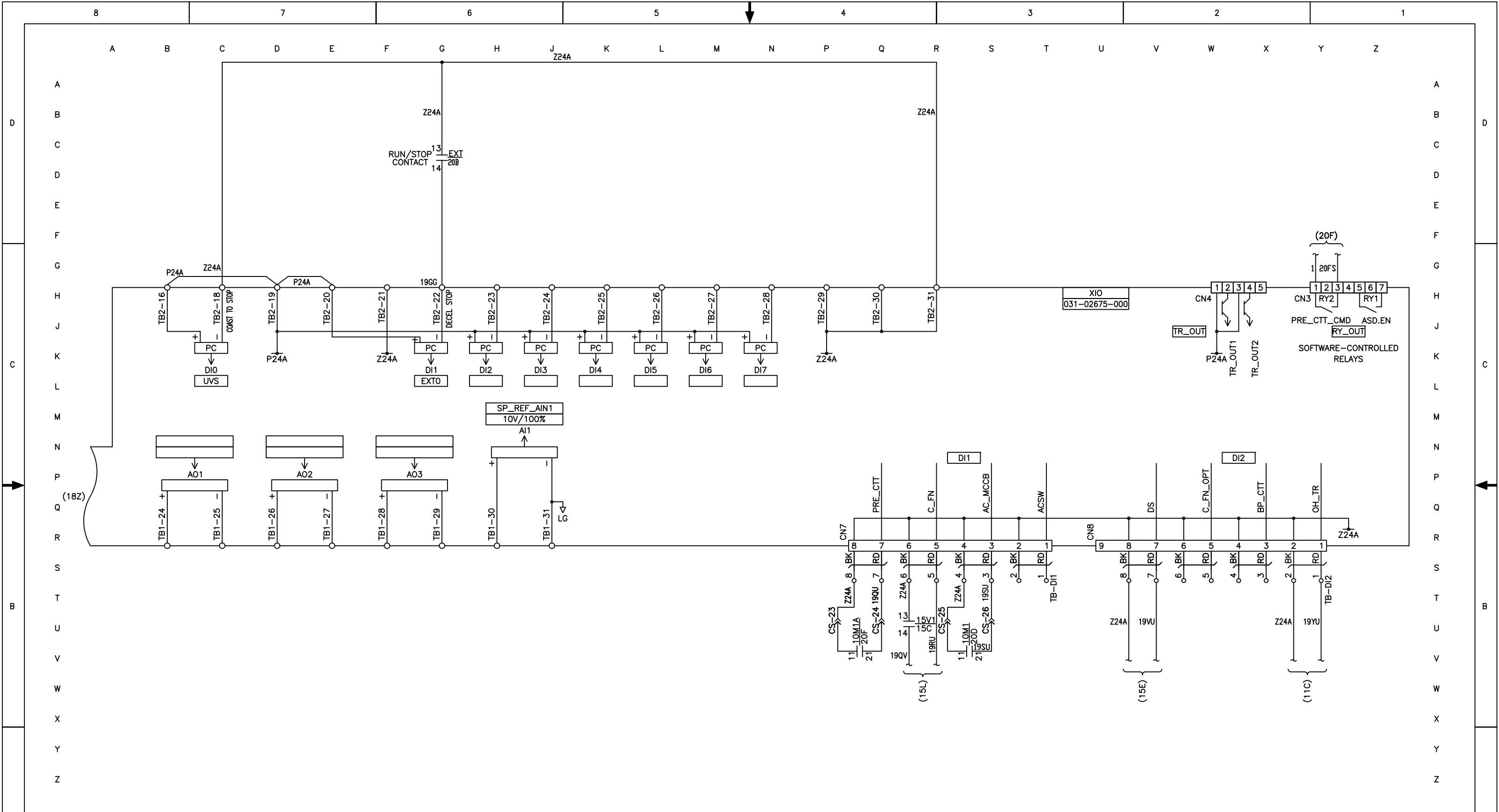

YORK INTERNATIONAL CORPORATION
YORK, PA . 17405

DIMENSIONS ARE IN INCHES DO NOT SCALE TOLERANCES PER ENG. STD. M-282 WELDING PER ENG. STD. M-30 REF. DWG.		EXTERNAL I/O (2)		MATERIAL TYPE _____ ENG. STD. _____ PART NO. _____ CUT SIZE _____	
DR. _____ APPR. _____ SCALE: _____	NAME _____ DATE _____	SIZE D	CAGE NO. _____	DRAWING NUMBER 1808JC19	
WT. = _____ LBS.		ORIG. NO. _____		SHEET 12 of 15	

REV. LEV.	DATE	REVISION RECORD	CHG. NO.	DR.	CK.	REV. LEV.	DATE	REVISION RECORD	CHG. NO.	DR.	CK.	REV. LEV.	DATE	REVISION RECORD	CHG. NO.	DR.	CK.
6						13						20					
5						12						19					
4						11						18					
3						10						17					
2						9						16					
1	06/05/14	UPGRADED TO ACE FORMAT		JO	AL	8						15					
0	04/20/06	FIRST ISSUE		OB	AL	7						14					

ALL PROPRIETARY RIGHTS IN THE SUBJECT MATTER HEREOF ARE RESERVED, AND NO PERMISSION IS GRANTED TO REPRODUCE THIS PRINT IN WHOLE OR IN PART, OR DISCLOSE ANY OF THE INFORMATION UPON IT TO OTHERS WITHOUT WRITTEN RELEASE BY YORK INTERNATIONAL CORPORATION.

CHILLER SYSTEM INTERFACE

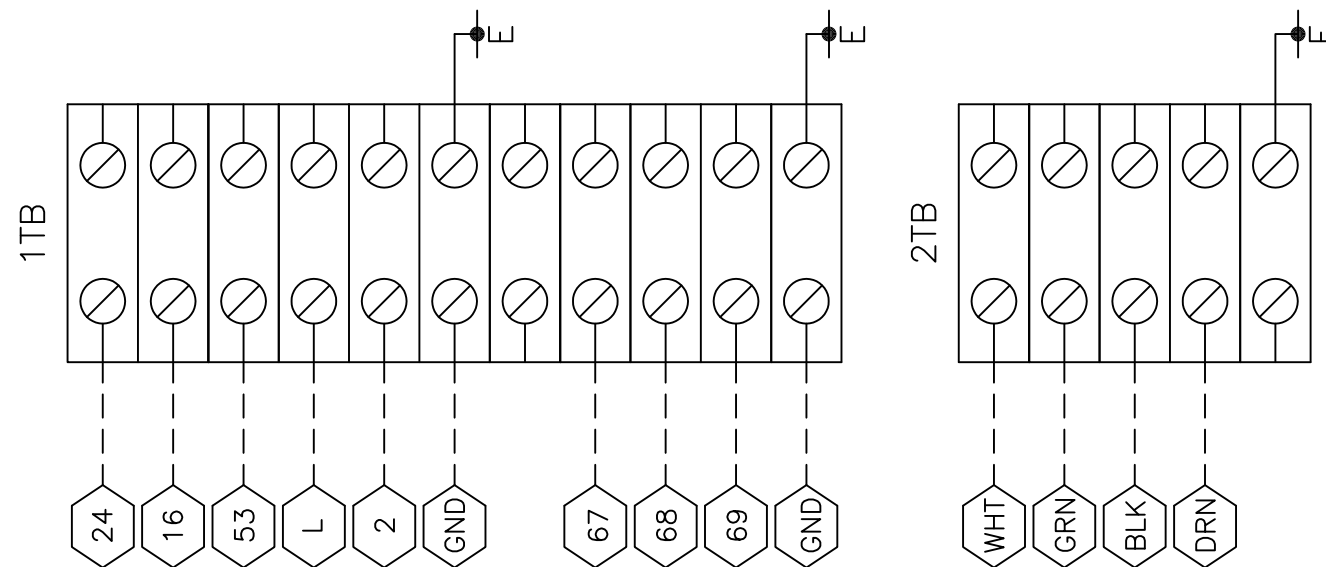

CUSTOMER TERMINAL BLOCK

REV. LEV.	DATE	REVISION RECORD	CHG. NO.	DR.	CK.	REV. LEV.	DATE	REVISION RECORD	CHG. NO.	DR.	CK.	REV. LEV.	DATE	REVISION RECORD	CHG. NO.	DR.	CK.
6						13						20					
5						12						19					
4						11						18					
3						10						17					
2	06/06/14	UPGRADED TO ACE FORMAT		JO	AL	9						16					
1	02/05/08	REMOVED 2TB JUMPER		OB	AL	8						15					
0	06/17/06	FIRST ISSUE		OB	AL	7						14					

*ALL PROPRIETARY RIGHTS IN THE SUBJECT MATTER HEREOF ARE RESERVED, AND NO PERMISSION IS GRANTED TO REPRODUCE THIS PRINT IN WHOLE OR IN PART, OR DISCLOSE ANY OF THE INFORMATION UPON IT TO OTHERS WITHOUT WRITTEN RELEASE BY YORK INTERNATIONAL CORPORATION.

YORK INTERNATIONAL CORPORATION YORK, PA .17405			
DIMENSIONS ARE IN INCHES DO NOT SCALE TOLERANCES PER ENG. STD. M-282 WELDING PER ENG. STD. M-30 REF. DWG.	CHILLER SYSTEM TERMINAL CONNECTIONS	MATERIAL TYPE _____ ENG. STD. _____ PART NO. _____ CUT SIZE _____	
DR. _____ APPR. _____ SCALE: _____	NAME _____ DATE _____ SIZE D	CAGE NO. _____ ORIG. NO. _____	DRAWING NUMBER 1808JC28 SHEET 14 of 15
WT. = _____ LBS.		SHEET 14 of 15	

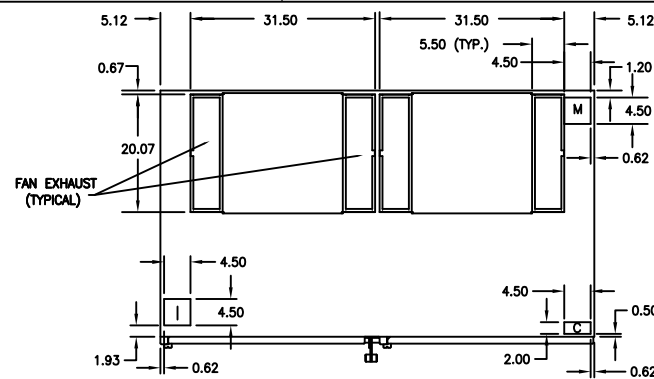

TOP VIEW

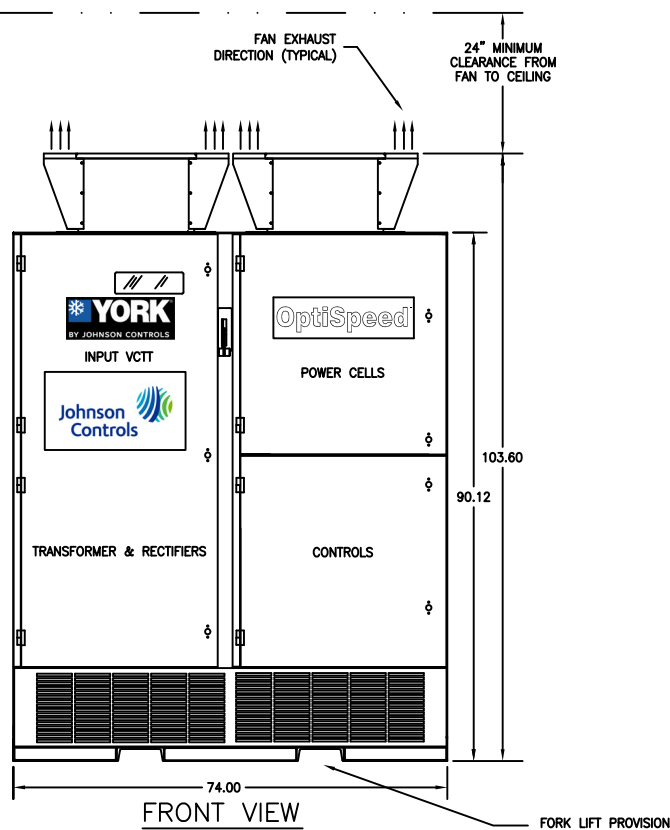

FRONT VIEW

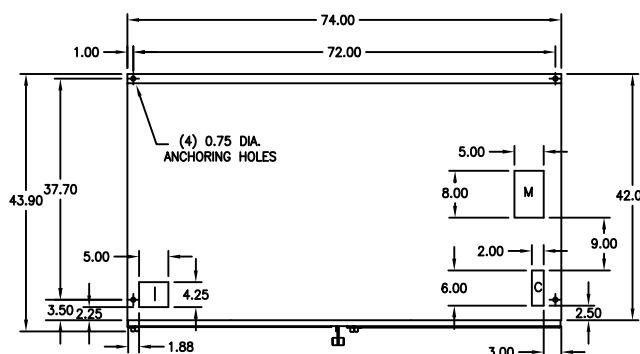

FLOOR PLAN VIEW

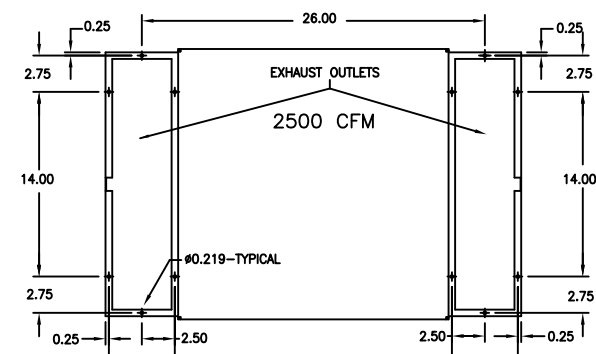

TYPICAL EXHAUST FAN HOLE PATTERN FOR CUSTOMER DUCTWORK (TOP VIEW)

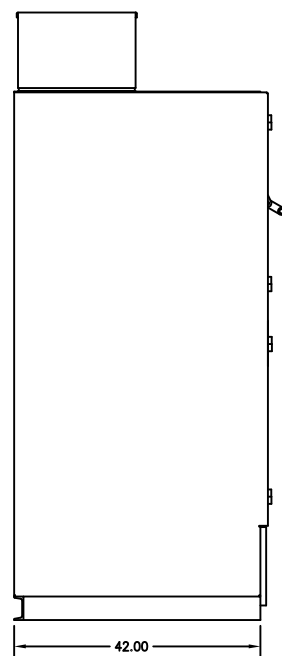

LH VIEW

CABLE TERMINATIONS			
ENTRY	INCOMING CABLES	MOTOR LEADS	CONTROL WIRE
TOP	I	M	C
BOTTOM	I	M	C

INCOMING TERMINATIONS USE NEMA 4-HOLE PATTERN
MOTOR TERMINATIONS USE NEMA 2-HOLE PATTERN

NOTES
 1. ENCLOSURE TYPE: NEMA 1 W/GASKETED DOORS
 2. ALL WEIGHTS ARE APPROXIMATE
 3. ALL DIMS ARE IN INCHES
 4. POWER CELLS NEED TO BE REMOVED FOR ACCESS

	500HP	600HP	700HP	800HP	900HP
VFD	6,400 lbs	6,600 lbs	6,800 lbs	7,200 lbs	7,500 lbs

YORK INTERNATIONAL CORPORATION
 YORK, PA . 17405

DIMENSIONS ARE IN INCHES DO NOT SCALE TOLERANCES PER ENG. STD. M-282 WELDING PER ENG. STD. M-30 REF. DWG.		OUTLINE ENCLOSURE		MATERIAL TYPE _____ ENG. STD. _____ PART NO. _____ CUT SIZE _____	
DR. _____	DATE _____	SIZE D	CAGE NO _____	DRAWING NUMBER 1808JC30	
APPR. _____	SCALE _____	WT. = _____	LBS. _____	ORIG. NO. _____	SHEET 15 of 15

REV. LEV.	DATE	REVISION RECORD	CHG. NO.	DR.	CK.	REV. LEV.	DATE	REVISION RECORD	CHG. NO.	DR.	CK.	REV. LEV.	DATE	REVISION RECORD	CHG. NO.	DR.	CK.
6						13						20					
5						12						19					
4						11						18					
3						10						17					
2						9						16					
1	07/22/10	LABEL CHANGE		XZ	AL	8						15					
0	06/17/06	FIRST ISSUE		OB	AL	7						14					

ALL PROPRIETARY RIGHTS IN THE SUBJECT MATTER HEREOF ARE RESERVED, AND NO PERMISSION IS GRANTED TO REPRODUCE THIS PRINT IN WHOLE OR IN PART, OR DISCLOSE ANY OF THE INFORMATION UPON IT TO OTHERS WITHOUT WRITTEN RELEASE BY YORK INTERNATIONAL CORPORATION.