



MILLENNIUM VARIABLE SPEED DRIVE

SERVICE INSTRUCTIONS

Supersedes: 160.00-M1 (200)

Form 160.00-M1 (702)



28561A

YORK MODEL YK CHILLER WITH OPTIONAL VARIABLE SPEED DRIVE

| VSD SIZE (HP) | |
|---------------|-------|
| 60 HZ | 50 HZ |
| 351 | 292 |
| 503 | 419 |
| 790 | 658 |
| 1100 | 900 |

TABLE OF CONTENTS

| | |
|--|----|
| VSD Style Variations | 3 |
| VSD / Harmonic Filter Component Overview | 3 |
| VSD Control System Overview | 7 |
| Control Panel VSD Related Keypad Functions | 12 |
| VSD Adaptive Capacity Control | 14 |
| VSD Display Messages | 15 |
| Start-Up Preparations | 22 |
| Frequently Asked Questions | 23 |
| EPRM Reference List | 28 |

Changeability:

In complying with YORK's policy for continuous product improvement, the information contained in this document is subject to change without notice. While YORK makes no commitment to update or provide current information automatically to the manual owner, that information, if applicable, can be obtained by contacting your local YORK Service Office. It is the responsibility of the reader (operator / service person) to verify the applicability of these documents to the equipment in question. If there is any question in the mind of the reader (operator / service person) as to the applicability of these documents, then prior to working on the equipment, they should verify with owner whether the equipment has been modified and if the current literature is available.

Use of Document:

This document is intended for use by owner-authorized operators and / or service personnel. It is expected that this owner-authorized individual will possess independent training that will enable them to perform their assigned tasks properly and safely. It is essential that prior to performing any task on this equipment, that the individual shall have read and understood this document, any referenced materials contained therein, and be familiar with and comply with all applicable federal, state and local standards and regulations pertaining to the task in question.

It is the obligation and responsibility of the owner-authorized individual to work safely. Failure to comply with any of these requirements could result in serious damage to the equipment and the property in which it is situated, as well as severe personal injury or death to people at the site.

General Safety Guidelines:

This equipment is a relatively complicated apparatus. During installation, operation, maintenance or service, individuals may be exposed to certain components or conditions including, but not limited to, refrigerants, oils, materials under pressure, rotating components and electrical voltage. Each of these items has the potential, if misused or handled improperly, to injure. It is essential that the technician / operator identify and recognize these inherent hazards and proceed safely in completing their tasks.



Bodily injury or death may result from high voltage electrical components and controls as well as from rotating equipment. During installation or any service/maintenance, the electrical supply should be disconnected, locked out and tagged. If any testing, service or maintenance must be done while the equipment is still energized, then it is the responsibility of the person performing these tasks to identify all possible risks to personal safety that they may be exposed to during the course of performing the task and only proceed when that individual feels that the task can be completed safely and with minimal risk.

VSD STYLE VARIATIONS

Original Style –

| Model Number | Part Number |
|--------------|---------------|
| 351 -46 | 371-01742-XXX |
| 503 -46 | 371-01484-XXX |
| 790 -46 | 371-01749-XXX |

Style “A” – This series applies to 503 HP only. Ground fault protection was incorporated into the circuit breaker, rather than utilizing separate GFI modules.

| Model Number | Part Number |
|--------------|---------------|
| 503 -46A | 371-02241-XXX |

Style “B” – This series includes wire harness changes to address 50HZ, higher voltage scaling on the ‘519’ Filter Logic Board with matching software changes, and various other software modifications. Note: Style “B” Software cannot be installed in Style A units without also making significant hardware changes.

| Model Number | Part Number |
|------------------|---------------|
| 351 -46B | 371-02289-XXX |
| 503 -46B | 371-02291-XXX |
| 790 -46B | 371-02293-XXX |
| 292 -50B (50 HZ) | 371-02249-XXX |
| 419 -50B (50 HZ) | 371-02248-XXX |
| 658 -50B (50 HZ) | 371-02247-XXX |

Style “C” – This series is identical to the Style B series, except that the circuit breaker and some fuses have been changed to permit a 65,000 A. Short-Circuit Rating.

| Model Number | Part Number |
|------------------|---------------|
| 351 -46C | 371-02412-XXX |
| 503 -46C | 371-02413-XXX |
| 790 -46C | 371-02414-XXX |
| 292 -50C (50 HZ) | 371-02415-XXX |
| 419 -50C (50 HZ) | 371-02416-XXX |
| 658 -50C (50 HZ) | 371-02417-XXX |

Style “D” – This series incorporates changes to the ‘519’ Filter Logic Board and Filter Gate Driver Board, resulting in improved Percent TDD values:

| Model Number | Part Number |
|--------------|---------------|
| 351 -46D | 371-02526-XXX |
| 503 -46D | 371-02527-XXX |
| 790 -46D | 371-02528-XXX |
| 1100 -46D | 371-02461-XXX |
| 292 -50D | 371-02529-XXX |
| 419 -50D | 371-02530-XXX |
| 658 -50D | 371-02531-XXX |
| 900 -50D | 371-02532-XXX |

- XXX Suffix:

| | |
|------|------------------------------|
| -101 | Factory Package YT Basic |
| -102 | Factory Package YK Basic |
| -103 | Factory Package YT w/ Filter |
| -104 | Factory Package YK w/ Filter |
| -111 | Retrofit YT Basic |
| -112 | Retrofit YK Basic |
| -113 | Retrofit YT w/ Filter |
| -114 | Retrofit YK w/ Filter |

VSD/HARMONIC FILTER COMPONENT OVERVIEW

Variable Speed Drive

The new YORK VSD is a liquid cooled, transistorized, PWM inverter packaged in a compact cabinet small enough to mount directly onto the chiller and directly onto the motor. The power section of the drive is composed of four major blocks: an AC to DC rectifier section with accompanying pre-charge circuit and free-wheeling diode, a DC link filter section, a three phase DC to AC inverter section and an output suppression network.

The AC to DC rectifier utilizes a semi-converter formed by the connection of three SCR/diode modules (1SCR-3SCR) in a three-phase bridge configuration (Fig. 1). The modules are mounted on a liquid cooled heatsink. Use of the semi-converter configuration permits implementation of a separate pre-charge circuit to limit the flow of current into the DC link filter capacitors when the drive is switched on and it also provides a fast disconnect from the power mains when the drive is switched off. When the drive is turned off, the SCRs in the semi-converter remain in a non-conducting mode and the DC link filter capacitors remain uncharged. When the drive is commanded to run, a set of precharge resistors (1RES, 2RES) are switched into the circuit by contactor 1M. The DC link filter capacitors are slowly charged via the precharge resistors and the diodes of the semi-converter for a fixed time period of 15 seconds. After the 15-second time period has expired, the SCR’s are gated fully on and the contactor 1M is dropped out. A “free-wheeling” diode 1CR is included to reduce the surge current which must be conducted through the semi-converter if a serious fault were to occur across the DC link. Three power fuses 1FU-3FU and an electronic circuit breaker 1SW with ground fault sensing connects the AC to DC converter to the power mains. Very fast semiconductor power fuses are utilized to ensure that the SCR/diode module packages do not rupture if a catastrophic failure were to occur on the DC link. The SCR Trigger board (031-01472) provides the gating pulses for the SCR’s as commanded by the VSD Logic board (031-01433).

The DC Link filter section of the drive consists of two basic components, a DC Link “smoothing” inductor or pair of inductors (1L,2L) and a series of electrolytic filter capacitors (C1-C36). This inductor / capacitor combination forms a low pass L-C filter which effectively smooths the ripple voltage from the AC to DC rectifier while simultaneously providing a large energy reservoir for use by the DC to AC inverter section of the drive. In order to achieve a suitable voltage capability for the capacitor portion of the filter, filter capacitor “banks” are formed by connecting two capacitors in series to form a “pair”, and then paralleling a suitable number of “pairs” to form a capacitor “bank”. In order to assure an equal sharing of the voltage between the series connected capacitors, and to provide a discharge means for the capacitor bank

when the VSD is powered off, “bleeder” resistors (3RES and 4RES) are connected across the capacitor banks.

The DC to AC inverter section of the VSD serves to convert the rectified and filtered DC back to AC at the magnitude and frequency commanded by the VSD Logic board. The inverter section is actually composed of three identical inverter output phase assemblies. These assemblies are in turn composed of a series of Insulated Gate Bipolar Transistor (IGBT) modules (Q1-Q4) mounted to a liquid cooled heatsink, a filter capacitor “bank” (C13-C20) and a VSD Gate Driver board (031-01476) which provides the On and Off gating pulses to the IGBT’s as determined by the VSD Logic board. In order to minimize the parasitic inductance between the IGBT’s and the capacitor banks, copper plates which electrically connect the capacitors to one another and to the IGBT’s are connected together using a “laminated bus” structure. This “laminated bus” structure is actually composed of a pair of copper bus plates with a thin sheet of insulating material acting as the separator/insulator. The “laminated bus” structure forms a parasitic capacitor which acts as a small valued capacitor, effectively canceling the parasitic inductance of the busbars themselves. To further cancel the parasitic inductances, a series of small film capacitors (C43-C51) are connected between the positive and negative plates of the DC link. To provide electrical shielding for the VSD Gate Driver board, an IGBT driver “shield board” (031-01627) is mounted just beneath the VSD Gate Driver board.

The VSD output suppression network is composed of a series of capacitors (C61-C66) and resistors (5RES-10RES) connected in a three-phase delta configuration. The parameters of the suppression network components are chosen to work in unison with the parasitic inductance of the DC to AC inverter sections in order to simultaneously limit both the rate of change of voltage and the peak voltage applied to the motor windings. By limiting the peak voltage to the motor windings, as well as the rate-of-change of motor voltage, we can avoid problems commonly associated with PWM motor drives, such as stator-winding end-turn failures and electrical fluting of motor bearings.

Various ancillary sensors and boards are used to convey information back to the VSD Logic board. Each liquid cooled heatsink within the DC to AC inverter section contains a thermistor heatsink temperature sensor (RT1-RT3) to provide temperature information to the VSD logic board. The AC to DC semi-converter heatsink temperature is also monitored using thermistor temperature sensor RT4. The Bus Isolator board (031-01624) utilizes three resistors on the board to provide a “safe” impedance between the DC link filter capacitors located on the output phase bank assemblies and the VSD logic board. It provides the means to sense the positive, midpoint and negative connection points of the VSD’s DC link. A Cur-

rent Transformer (3T-5T) is included on each output phase assembly to provide motor current information to the VSD logic board.

Harmonic Filter Option

The VSD system may also include an optional harmonic filter designed to meet the IEEE Std 519 -1992, “IEEE Recommended Practices and Requirements for Harmonic Control in Electrical Power Systems”. The filter is offered as a means to “clean up” the input current waveform drawn by the VSD from the power mains, thus reducing the possibility of causing electrical interference with other sensitive electronic equipment connected to the same power source.

Figure 2A is a plot of the typical input current waveform for the VSD system without the optional filter when the system is operating at 50% load. Figure 2B is a plot of the typical input current waveform for the VSD system with the optional harmonic filter installed when operating at the same load conditions. The plots show that the input current waveform is converted from a square wave to a fairly clean sinusoidal waveform when the filter is installed. In addition, the power factor of the system with the optional filter installed corrects the system power factor to nearly unity.

The power section of the Harmonic Filter is composed of four major blocks: a pre-charge section, a “trap” filter network, a three phase inductor and an IGBT Phase Bank Assembly (see figure 4).

The pre-charge section is formed by three resistors (11RES - 13RES) and two contactors, pre-charge contactor 2M and supply contactor 3M. The pre-charge network serves two purposes, to slowly charge the DC link filter capacitors associated with the filter Phase Bank Assembly (via the diodes within the IGBT modules Q13-Q18) and to provide a means of disconnecting the filter power components from the power mains. When the drive is turned off, both contactors are dropped out and the filter phase bank assembly is disconnected from the mains. When the drive is commanded to run, the pre-charge resistors are switched into the circuit via contactor 2M for a fixed time period of 5 seconds. This permits the filter capacitors in the phase bank assembly to slowly charge. After the 5-second time period, the supply contactor is pulled in and the pre-charge contactor is dropped out, permitting the filter Phase Bank Assembly to completely charge to the peak of the input power mains. Three power fuses (11FU -13FU) connect the filter power components to the power mains. Very fast semiconductor power fuses are utilized to ensure that the IGBT modules do not rupture if a catastrophic failure were to occur on the DC link of the filter phase bank assembly.

CONTINUED
ON PAGES
5B & 6

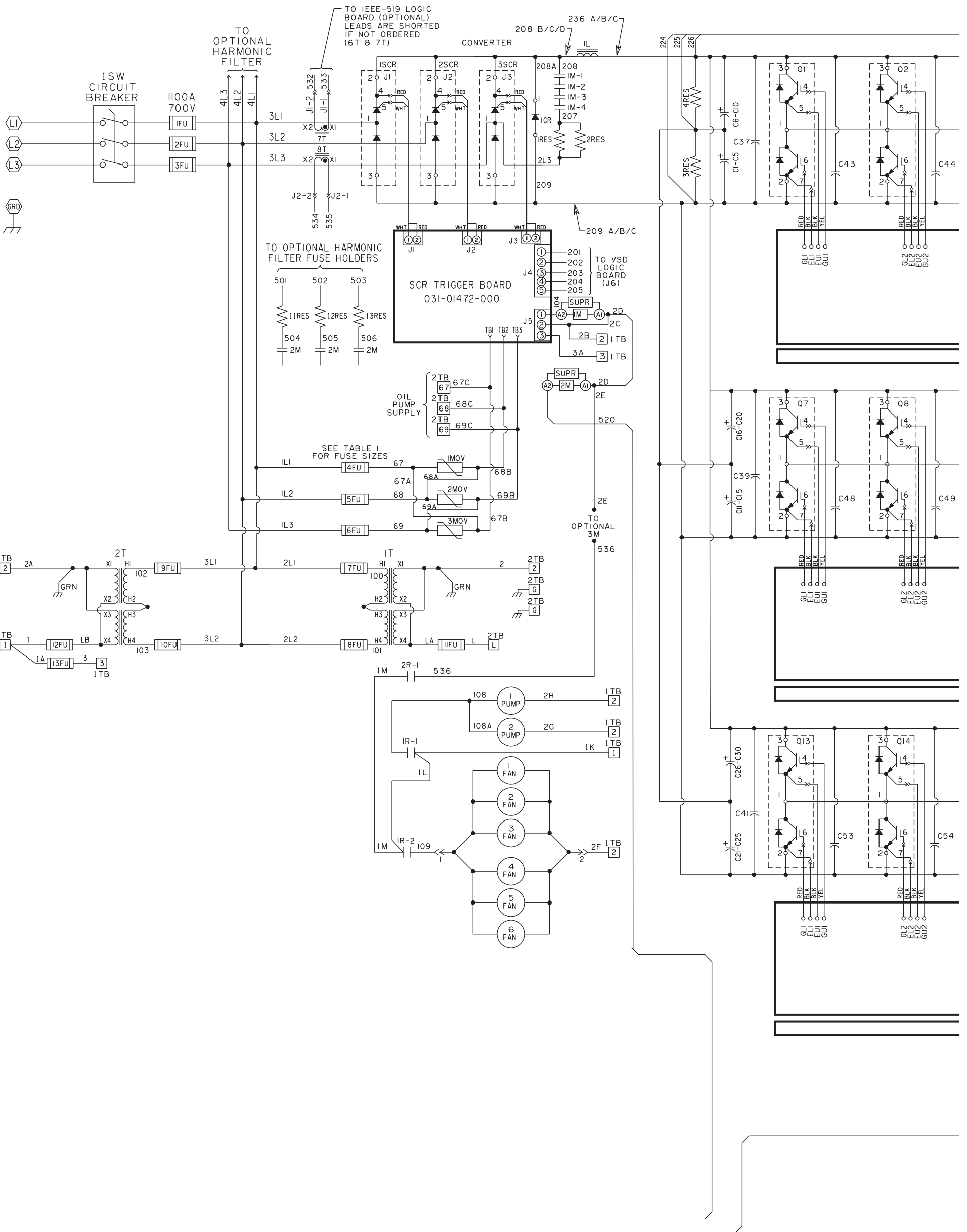
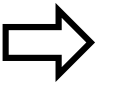

FORM 160.00-M1 (702)

FORM 160.00-M1 (702)

FIG. 1 - AC TO DC CONVERTER AND DC LINK FILTER

LD02724

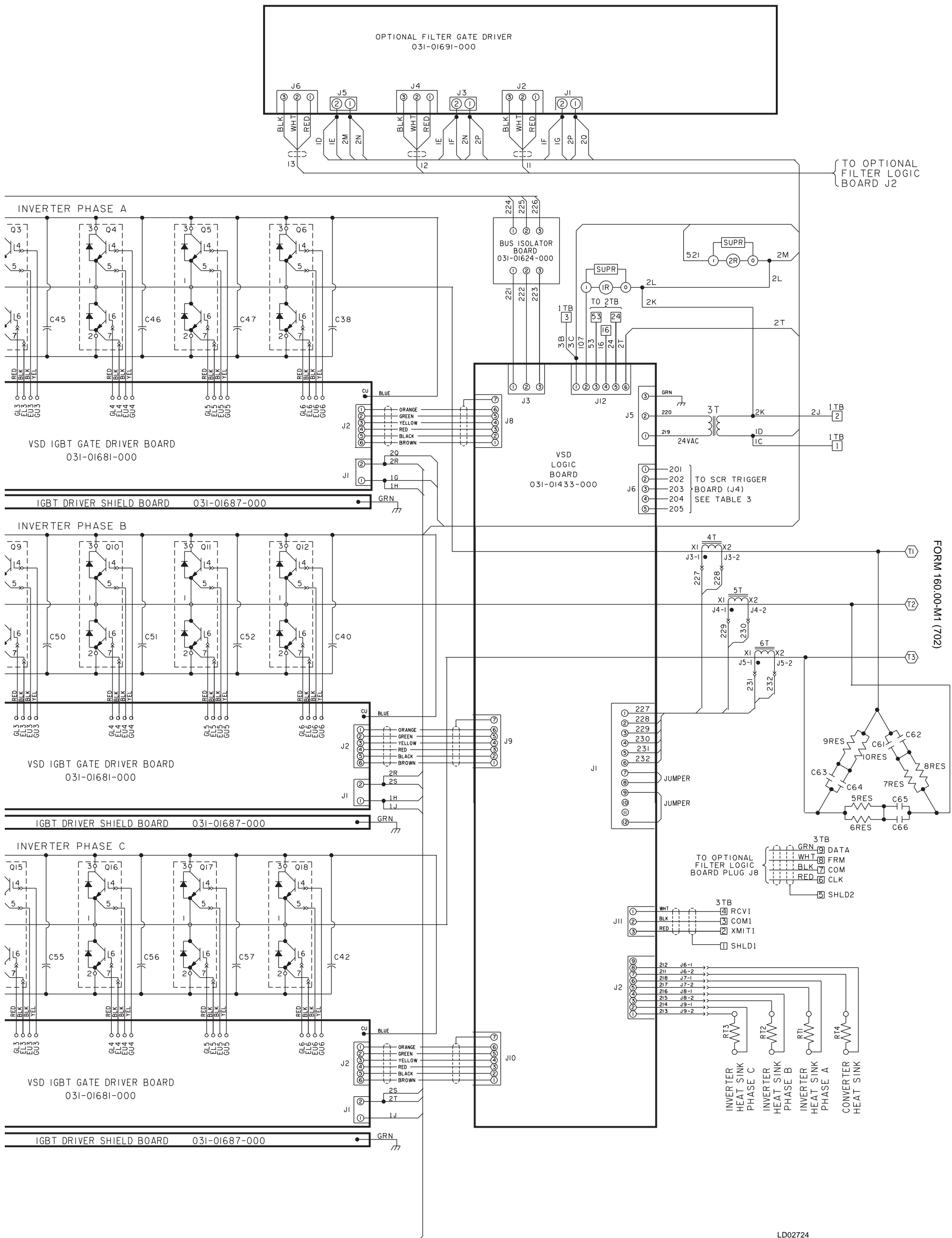

FORM 160.00-M1 (702)

LD02724

FIG. 1 (Cont'd) – AC TO DC CONVERTER AND DC LINK FILTER

The “**trap**” filter is composed of a series of capacitors (C84-C92), inductors (4L-6L) and resistors (16RES-18RES). The “trap” filter acts as a low impedance for a range of frequencies centered at the PWM switching frequency of the filter (20 KHz). The purpose of the trap is to block currents at the switching frequency of the filter from getting onto the power mains.

The **three phase inductor** provides some impedance for the filter to “work against”. It effectively limits the rate of change of current at the input to the filter to a reasonable level.

The **IGBT Phase Bank Assembly** is the most complicated power component in the optional filter. Its purpose is to generate the harmonic currents required by the VSD’s AC-to-DC converter so that these harmonic currents are not drawn from the power mains. The phase bank is composed of a series of IGBT modules (Q13-Q18) mounted to a liquid cooled heatsink, a filter capacitor “bank” (C67-C76) and an IEEE 519 Filter Gate Driver board (031-01626) which provides the On and Off gating pulses to the IGBT’s as determined by the 519 Filter Logic board. In order to assure an equal sharing of the voltage between the series connected capacitors on the filter bank, “bleeder” resistors 14RES and 15RES are connected across the banks. In order to counteract the parasitic inductances in the mechanical structure of the phase bank, the filter incorporates “laminated bus” technology and a series of small film capacitors (C77-C83). The technology used is identical to that used in the VSD’s DC to AC inverter section of the drive.

Various ancillary sensors and boards are used to convey information back to the Filter Logic board. A thermistor temperature sensor RT5 is mounted onto the liquid cooled heatsink to provide temperature information. Current Transformers 6T and 7T sense the input current drawn by the VSD’s AC to DC converter. DC Current Transformers DCCT1 and DCCT2 sense the current generated by the optional filter. The Line Voltage Isolation board (031-01625) senses the input voltage to the system, steps the voltage down to a safe level and provides isolation between the Filter Logic board and the power mains. The Bus Isolation board (031-01624) incorporates three resistors to provide a “safe” impedance between the DC filter capacitors located on the phase bank assembly and the Filter logic board. It provides the means to sense the positive, midpoint and negative connection points of the filter’s DC link.

VSD CONTROL SYSTEM OVERVIEW

The VSD control system is composed of various components located within both the Microcomputer Control Center and the VSD thus integrating the Control Center with the VSD Drive. The VSD system utilizes various microprocessors and Digital Signal Processors (DSPs)

which are linked together through a network of parallel and serial communications links.

MicroComputer Control Center

The MicroComputer Control Center contains two boards that act upon VSD related information, the Microboard (031-01065) and the Adaptive Capacity Control board (031-01579). The ACC board performs two major functions in the VSD control system - (1) to act as a gateway for information flow between the Micro Computer Control Center and the VSD and (2) to determine the optimum operating speed and vane position for maximum chiller system efficiency by implementing a totally new and novel means of Capacity Control.

The ACC board acts as an information gateway for all data flowing between the VSD and the Control Center. The ACC board communicates serially with both the VSD logic board (via J8 on the ACC board) and the optional Harmonic Filter logic board (via J9 on the ACC board) using a pair of shielded cables. Once the information is received by the ACC board, the information is then passed on to the Microboard via two ribbon cables connecting the ACC to the Microboard (J1 and J2 on the ACC board).

In order to achieve the most efficient operation of a centrifugal compressor, the speed of the compressor must be reduced to match the “lift” or “head” of the load. This “lift” or “head” is determined by the chilled and condenser water temperatures (and their corresponding refrigerant pressures). However, if the compressor speed is reduced too much, the refrigerant gas will flow backwards against the compressor wheel causing the compressor to “surge”, an undesirable and extremely inefficient operating condition. Thus there exists one particular optimum operating speed (on the “edge” of surge) for a given head, which provides the optimum system efficiency. The compressor’s inlet guide vanes, which are used in fixed speed applications to throttle the gas flowing through the compressor, are controlled together with the compressor speed on a VSD chiller system, to obtain the required chilled water temperature while simultaneously requiring minimum power from the power system.

The older Turbo-Modulator capacity control boards utilized a pre-programmed three dimensional surge surface map for each compressor/refrigerant combination; whereas the new ACC board automatically generates its own “Adaptive” three dimensional surge surface map while the chiller system is in operation. This “Adaptive” operation is accomplished through the use of a patented surge detection algorithm. The novel surge detection system utilizes pressure information obtained from the chillers’ pressure transducers in combination with the VSD’s instantaneous power output to determine if the system is in “surge”. Thus the adaptive system permits construction of a custom compressor map for each individual chiller system. Benefits of this new adaptive system in-

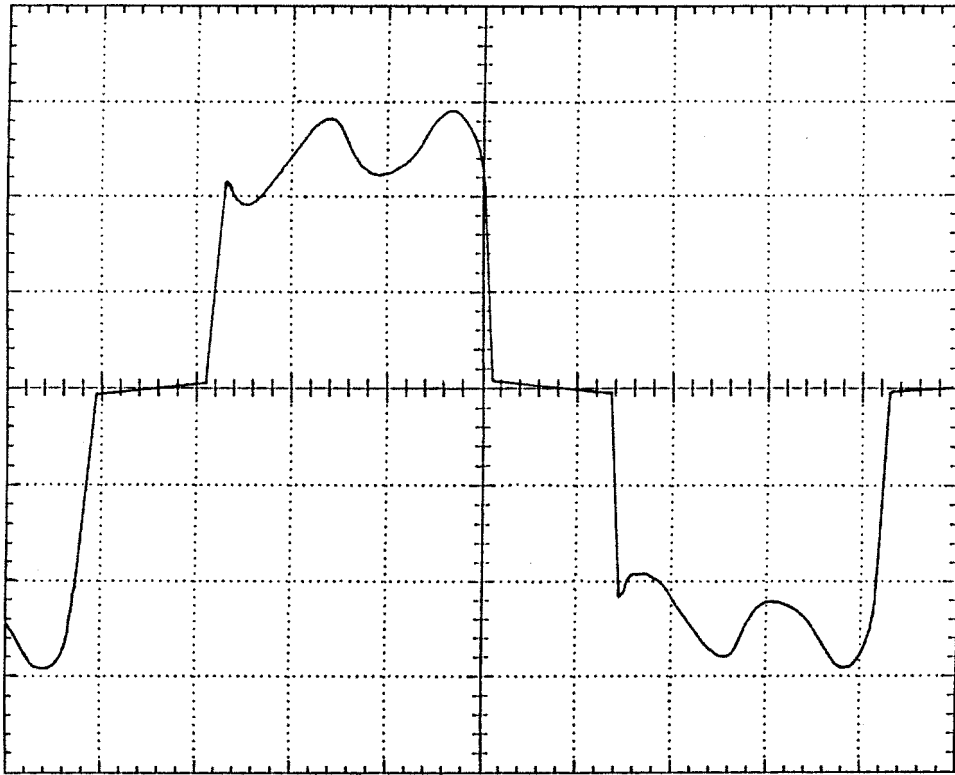

LD02726

FIG. 2A – VSD INPUT CURRENT WITHOUT FILTER

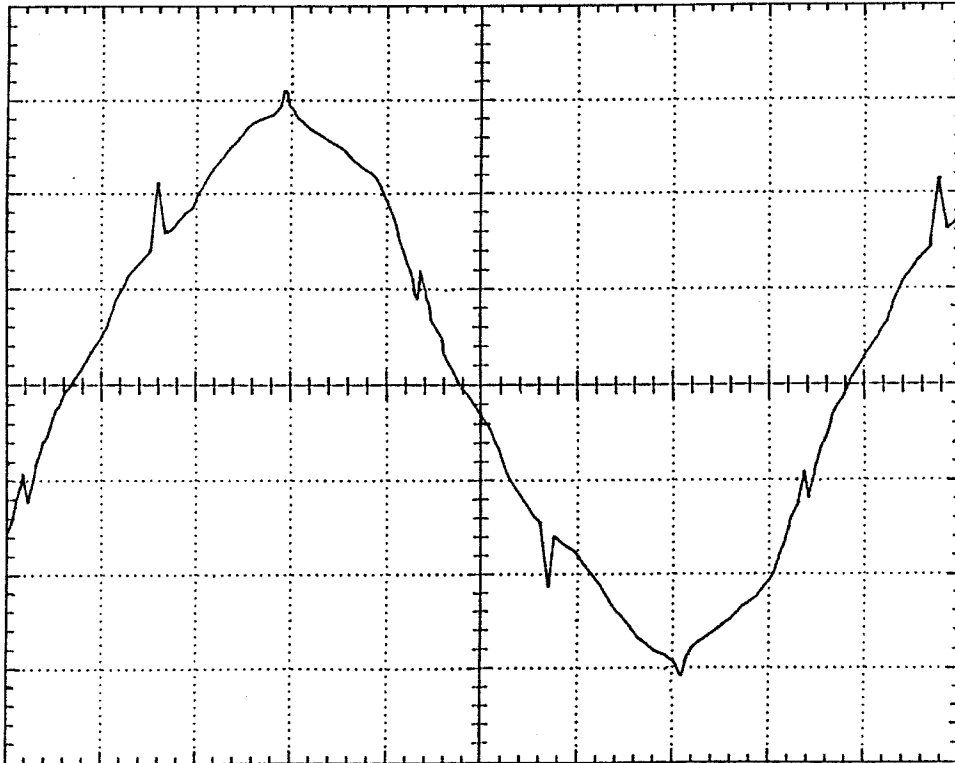

LD02727

FIG. 2B – VSD INPUT CURRENT WITH FILTER

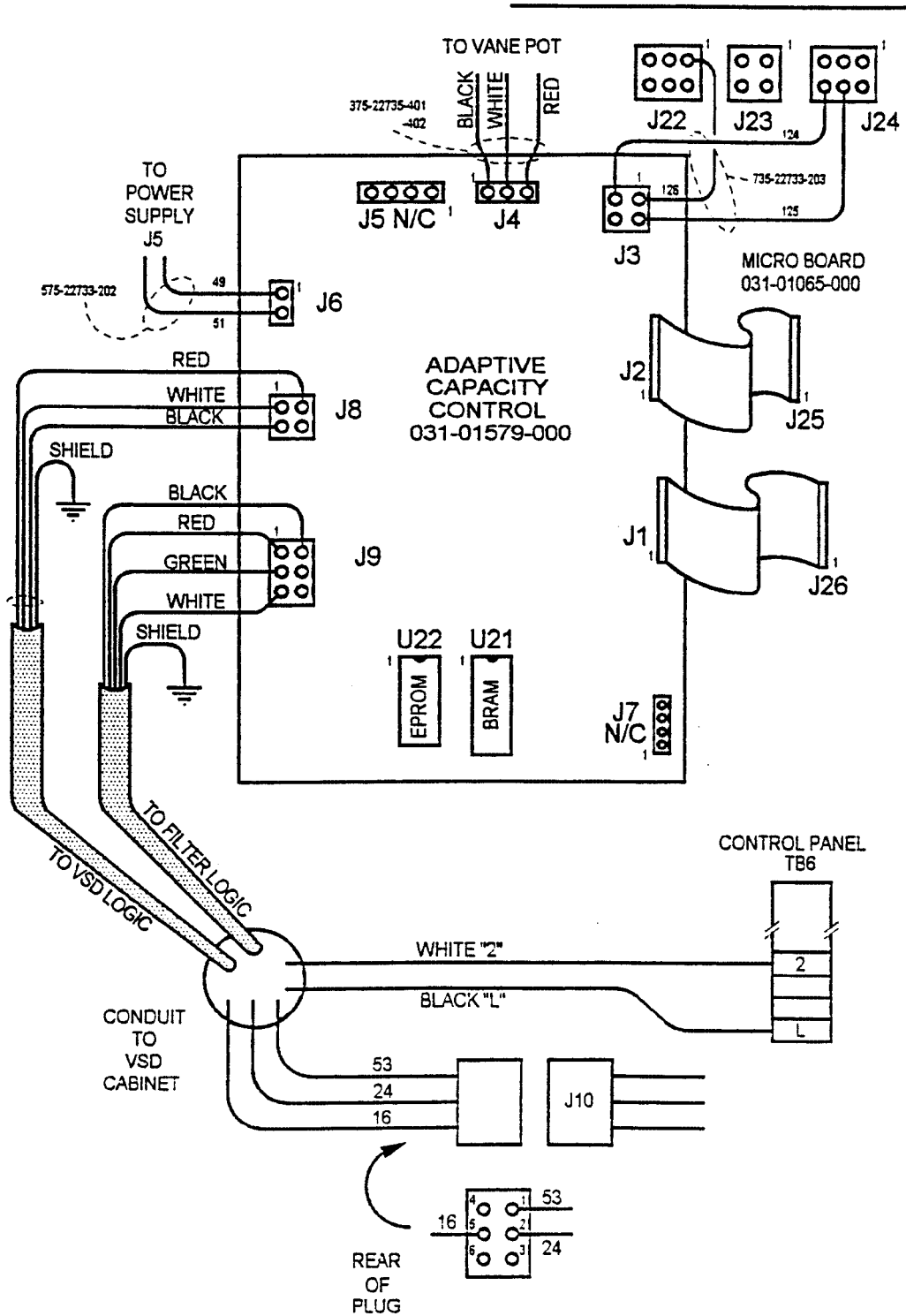

LD02969

NOTE:

This conduit routes to the lower left corner of the VSD cabinet. Terminals for each wire are located inside the VSD cabinet, adjacent to the conduit knock-out.

FIG. 3 – ADAPTIVE CAPACITY CONTROL BOARD (ACC)

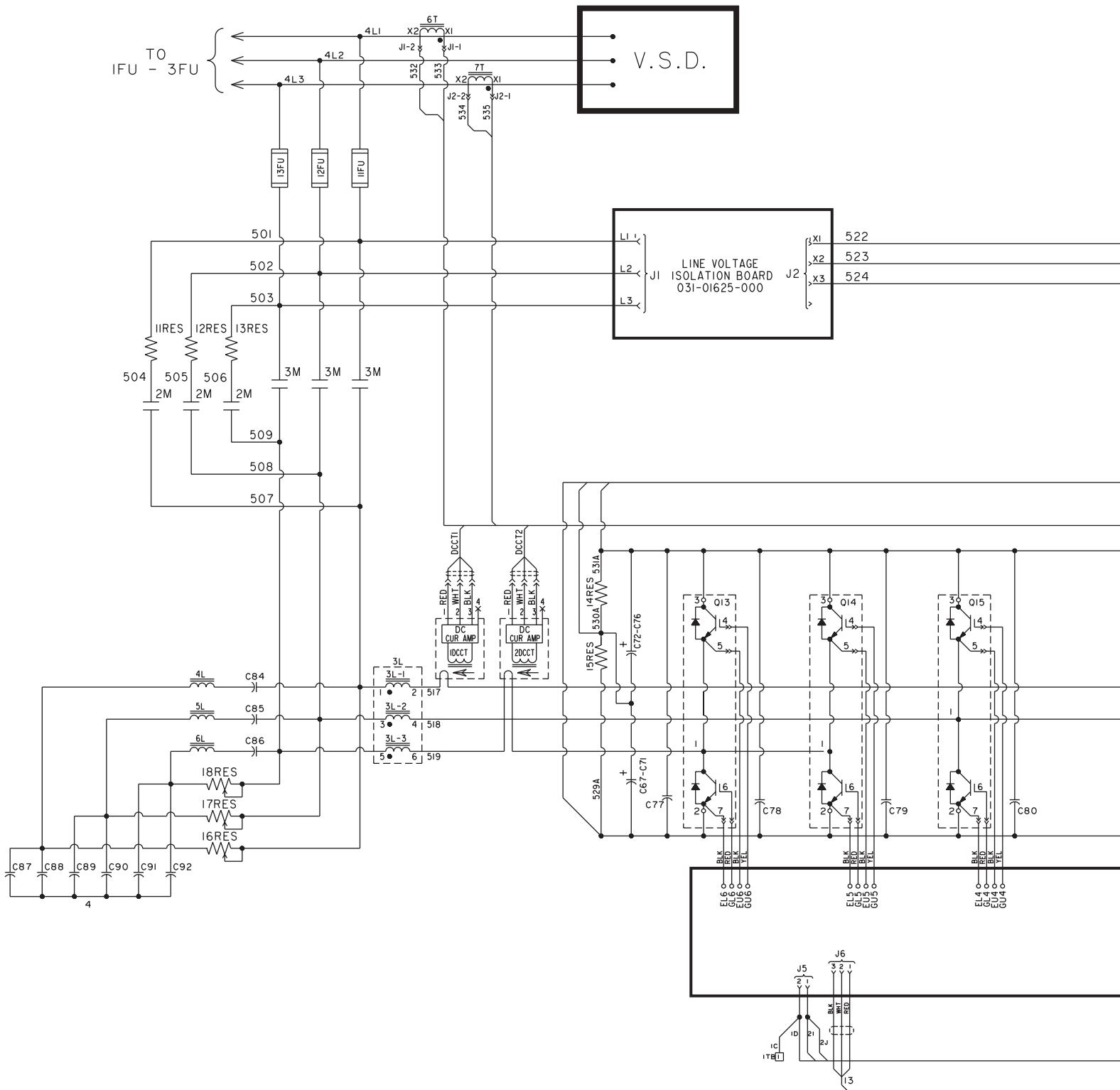
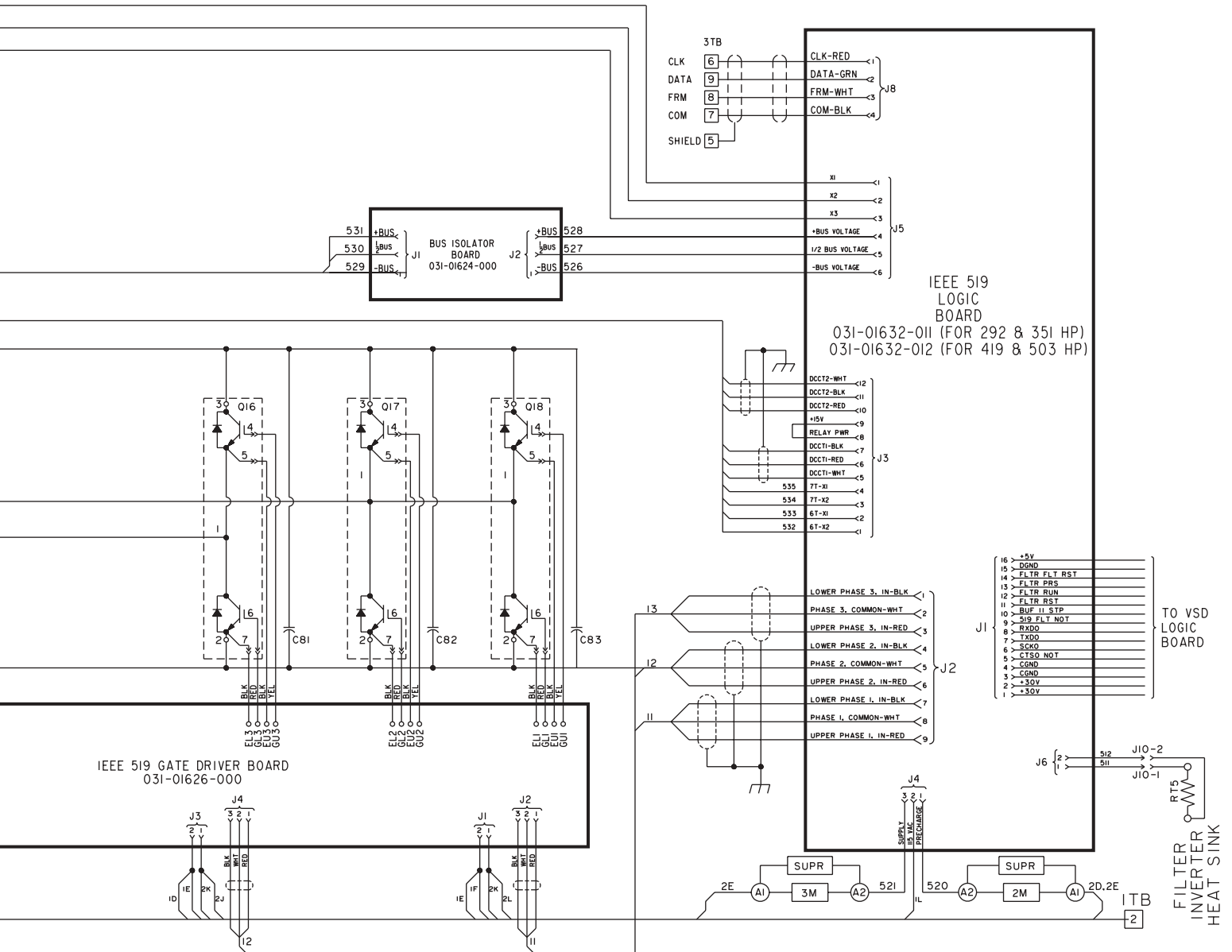

FIG. 4 – IEEE-519 FILTER OPTION



LD02725

clude: (1) a custom compressor map for each installation which eliminates inefficient operation due to the safety margin built into the previous programmed map controller which was necessary to compensate for compressor manufacturing tolerances (2) the ability to update the system's surge surface as the unit ages and (3) automatic updating of the compressor map if changes in refrigerant are implemented at a later date.

VSD and Optional Harmonic Filter Logic Control Boards

Within the VSD enclosure, the VSD logic board and optional Harmonic Filter logic boards are interconnected via a 16-position ribbon cable which joins the two boards together. The Filter Logic board derives its power from the VSD Logic board over this ribbon cable. In addition, various logic level "handshake" signals convey the operating status of the VSD to the Filter and vice versa over this cable. Finally, the cable includes a unidirectional serial communications link which permits the transmission of a limited amount of data from the VSD to the optional Harmonic Filter.

The VSD Logic board performs numerous functions, including control of the VSD's cooling fans and pumps, control of the pre-charge contactor, control of the semi-converter gating and generation of the PWM firing pulses which are sent to the VSD gate driver and ultimately gate the IGBT's on and off.

The VSD Logic board also gathers data from the Current Transformers which monitor the three phases of motor current, the heatsink temperatures, the internal ambient temperature within the enclosure and the DC Link voltage. This data is periodically sent to the Micro Computer Control Center via the ACC board.

CONTROL PANEL VSD RELATED KEYPAD FUNCTIONS

The following keypad functions are in addition to the standard keypad functions as addressed in the standard chiller literature. The features below are present only when the control panel is configured for operation with the VSD:

Options Key – When depressed, the display will show

VSD 100% JOB FLA = ___ A.

Additional lines of display are available by scrolling, using the white key labeled, "Advance Day / Scroll". All available lines are listed below:

VSD 100% JOB FLA = ___ A.

VSD DC LINK VOLTAGE = ___ V.

VSD DC LINK CURRENT = ___ A.

VSD INTERNAL AMBIENT TEMP = ___ °F.

VSD CONVERTER HEATSINK TEMP = ___ °F.

VSD PHASE A INVERTER HEATSINK TEMP = ___ °F.

VSD PHASE B INVERTER HEATSINK TEMP = ___ °F.

VSD PHASE C INVERTER HEATSINK TEMP = ___ °F.

VSD PRECHARGE RELAY DE-ENERGIZED (OR ENERGIZED)

VSD SCR GATE DRIVER DISABLED (OR ENABLED)

VSD COOLING PUMP STOPPED (OR RUNNING)

FILTER PRESENT (OR NOT PRESENT)

When the Filter is Present, these additional lines are available by scrolling:

FILTER HEATSINK TEMP = ___ °F.

FILTER CURR: A=___ A.; B=___ A.; C=___ A.

FILTER DC LINK VOLTAGE = ___ V.

INPUT PEAK V.: A=___ V.; B=___ V.; C=___ V.

FILTER STOPPED (RUNNING)

FILTER PRECHARGE RELAY DE-ENERGIZED (ENERGIZED)

FILTER SUPPLY RELAY DE-ENERGIZED (ENERGIZED)

INPUT PHASE ROTATION - ABC (CBA)

VSD Parameters Key – When this key is pressed, the VSD output frequency and voltage are displayed. Additional lines of display are available by pressing the white key labeled, "Advance Day / Scroll". All available lines are listed below:

OUTPUT FREQ ___ HZ; OUTPUT VOLTS ___ V.

OUTPUT CURR: A=___ A.; B=___ A.; C=___ A.

INPUT POWER = ___ KW; KWH = _____

When the Filter is present, these additional lines are available by scrolling:

INPUT KVA = ___; TOTAL PWR FACTOR = ___

INPUT V AB=___ V.; BC=___ V.; CA=___ V.

INPUT CURR A=___ A.; B=___ A.; C=___ A.

INPUT V THD: A=___%; B=___%; C=___%

INPUT CURR TDD%: A=___%; B=___%; C=___%

Display Data Key – This key functions as normal, but offers two additional lines of display with VSD operation. After scrolling through the normal displays, these additional lines are displayed:

D-P/P= ___; PRV POS = ___%; FREQ = ___ HZ

TOTAL ACC SURGE COUNTS = _____

VSD History Key – This key provides four historical records. Its exact operation varies, depending on the style level of the VSD and software. The two types of operation are as follows:

Original and Style "A" Units – Four previous safety / cycling messages are stored, listing the message, and indicating the historical order by placing the history number, one through four, in parenthesis after the message.

Using the white key labeled, “Advance Day / Scroll”, one can view the same lines of data as are available by pressing the “Options” and “VSD Parameters” keys. The data displayed will be that recorded at shutdown, if running - or will be data from the last time the chiller ran, if the message was generated while the chiller was idle. The recording of data from the last time the chiller ran, is consistent with history data records on all previous YORK micropanel designs. Below is an example of four histories:

```

22 OCT 1501 SERIAL RECEIVE FAULT (1)
21 OCT 1635 SYSTEM CYCLING - AUTOSTART (2)
20 OCT 1000 SYSTEM CYCLING - AUTOSTART (3)
20 OCT 0808 SYSTEM CYCLING - AUTOSTART (4)

```

These displays will appear sequentially while depressing the VSD History key. When the VSD History key is released, the message present at that time is maintained on the screen. With any one of these messages on the screen, the associated VSD operating data just prior to unit shutdown may be viewed by scrolling using the white “Advance Day / Scroll” key.

Style “B” Units – For the first time, we have implemented a system which records real-time data, even if the chiller is not running. Since four power losses, or four unsuccessful attempts at starting would overwrite data from the last time the chiller ran, specific history displays have been generated as follows:

```

CURRENT OR LAST SYSTEM RUN DATA
LAST SFTY / CYCL SHUTDOWN WHILE RUNNING
SFTY / CYCL SHUTDOWN HISTORY (1)
SFTY / CYCL SHUTDOWN HISTORY (2)

```

The above lines appear sequentially when the VSD History Key is depressed. When this key is released, the message being viewed at that time is maintained. Using the white “Advance Day / Scroll” key, the Display Status Message may be viewed, and by continuing to depress the white “Advance Day / Scroll” key, all VSD operating data from that instant in time may be viewed. For example, by depressing the VSD History key once, you will see:

```
CURRENT OR LAST SYSTEM RUN DATA
```

Now by depressing the white “Advance Day / Scroll” key, you might see:

```
21 OCT 0804 NO MALFUNCTION DETECTED
```

Depressing the white “Advance Day / Scroll” key again will display the first line of historical data. Continue to depress the white key to view all lines of data.

“Hidden” Key – There is an unmarked button on the face of the control panel membrane keypad, located just below the “Clock” key. When this button is pressed, you will see a display of four parameters:

```
DPP = X.XX; PRV = XXX%; LWTD = XX.X; FQ = XX HZ
```

- D-P/P, the ratio of the condenser pressure minus the evaporator pressure to the evaporator pressure.
- Percent Vane Position. 100% is wide open vanes.
- Delta T, the difference between the leaving water temperature setpoint and actual leaving water temperature.
- Output frequency in hertz.

Special Key Functions While in “VSD Service Mode” & and in “Program” – The following keys provide special functions when the panel is in VSD Service Mode, and also in the Program mode:

Chilled Liquid Temps – This key provides control over the ACC’s determination of stability, and programmed surge margin. Do not change these values unless instructed to do so by YORK factory service. When in VSD Service mode, and in program mode, the display will show:

```
STABILITY LIMIT = 4500
```

```
SURGE MARGIN ADJUST = 0.0 HZ
```

Press the Program key to exit this screen.

VSD Parameters – When in VSD Service mode and in program mode, manual programming of the VSD’s operating frequency over a range of 1 to 60 Hz is permitted. The display will show:

```
MANUAL VSD FREQUENCY = ____ HZ
```

Options – When in VSD Service mode and in program mode, use of this key permits the IEEE-519 Filter to be inhibited via software. The filter related parameters will still be displayed on the panel although the filter is inhibited. This feature can only be enabled while the chiller is shut down. The display will show:

```
DEFEAT IEEE-519 FILTER OPERATION? NO
```

Use the white “Advance Day / Scroll” key to change to YES, then press “Enter”.

Print – In the above stated modes, this key permits the compressor surge map to be dumped to a printer, or to be recorded to the printer as new surge points are determined. In this mode the Print key will display:

```
ENABLE PRINT MAP? NO; RESTART MAP? NO
```

Use the white “Advance Day / Scroll” key to change the NO to YES, then press the “Enter” key to begin printing. Answering “Yes” to “Enable Print Map” causes the printer to begin printing new points as they are mapped. Answering “Yes” to both questions causes the printer to begin printing all mapped points, beginning with the first point ever mapped. This could be hundreds of surge points.

VSD ADAPTIVE CAPACITY CONTROL

The new York VSD utilizes a different approach to speed reduction compared to earlier variable speed products. There is no pre-programmed surge map - our adaptive system experiments with the speed and vanes to find the optimum speed for any given condition. It does not always encounter a "Surge" in the process, but when it does, the ACC stores into memory, the conditions surrounding the Surge, and therefore remembers to avoid the stored operating point anytime in the future. This sounds a bit mysterious, but the process is really quite simple. Once you have an understanding of the steps involved, you will be able to watch the chiller adjust itself to different conditions, and understand exactly why it is performing in the manner it does.

Upon startup the chiller will always go to full speed. This is different compared to earlier systems which could go to a reduced speed if the total head across the chiller was low enough. With the VSD, the chiller will always run at fixed speed until two conditions are met. These two conditions are:

Achieve Setpoint - The leaving water temp must be within +0.3 to -0.6 of a degree from setpoint. Speed reduction will not occur until the leaving water reaches setpoint.

Achieve Stability - The leaving water temp must be stable, with the vanes not driving open or closed to maintain the temperature at this point. Lack of stability will be evidenced by the vanes hunting, the leaving water temperature varying, and the green LED on the ACC board will be on, to indicate instability.

Once the above conditions are met, the ACC begins to lower the speed 1/10 of a hertz at a time. As the ACC lowers the speed, the leaving water temperature will begin to creep up, due to the reduction in speed. As this occurs, you will see the vanes begin to open slightly, just enough to keep the leaving water temperature within the setpoint window. The ACC will continue to lower speed, with the leaving water temperature in turn driving the vanes to a more open position. This process will continue until one of three situations occur:

Vanes Full Open - Once the vanes reach the full open position, the ACC knows it can no longer reduce speed. The ACC will maintain operation at this point, with the vanes full-open, and the speed at the last point reached when the vanes hit 100%. If there is an increase in load while at this point, the ACC will increase speed until the vanes are at 95%. The ACC will then be allowed to continue to optimize the speed and vanes.

Surge is Detected - If in the process of dropping speed and opening vanes the compressor should surge, the ACC will boost the speed back up enough to get the chiller out of surge, and will store in memory the head and flow conditions present at the time of the surge. The chiller will then know not to reduce speed this low again, should the same head and flow conditions be encountered again in the future. As the chiller encounters more head and flow combinations which result in surge, it will store more points, and eventually this plotting of points creates a "Surge Map". Surges may be detected in two ways, by monitoring the pressure differential across the compressor, or by monitoring the compressor motor current. Either detection will light the Red LED on the ACC board, indicating a surge was detected. The chiller may surge 6 to 8 times before the ACC can raise the speed enough to get the chiller back out of surge. Each surge is counted on the surge accumulator, which may be called up on the panel display. This surge counter will always display the total number of surges encountered by the chiller, not the total number of surge points. Surging which occurs at fixed speed will increment the surge counter as well. We know of one chiller which ran in continuous surge for two weeks due to a cooling tower problem. The customer's fixed speed chiller was surging continuously for 2 weeks also. During this time, the VSD surge counter accumulated over 18,000 surges.

Instability is Encountered - The ACC may begin the process of reducing speed and opening the vanes, but may stop speed reduction prematurely if instability is encountered. This is the same instability discussed as one of the two conditions which must be met to begin reducing speed initially (See "Achieve Stability" above). Once the system again becomes unstable, no additional speed reduction can occur. The most common causes of instability are:

- Valves on air-handler coils causing rapid changes in heat-load.
- Extremely short chilled water loop.
- Parallel chiller with poor control is causing temperature variations.

If you experience a problem with a VSD not reducing speed at all, make certain the system is not in manual speed control, and locked into fixed speed. Refer to the section on "Manual Speed Control" in the "Frequently Asked Questions" section on page 23. Also, make certain the wiring at J3 on the ACC board is properly con-

nected per the wiring diagram in this same manual. Either situation will cause the chiller to maintain full speed.

If the VSD is reducing speed, but not running as low as you expect it should, it is likely because it is either in an unstable condition, or running just above a mapped surge point. As described above, the chiller must achieve stability, which is evidenced by the Green LED being extinguished. Instability will cause the Green LED to be illuminated. To determine if the chiller is running just above a surge point, switch the system to manual speed control, and force the speed lower by one or two hertz. If you encounter a surge, this explains why the chiller would not reduce speed. If you find the chiller does drop speed without surging, instability was likely preventing further speed reduction.

VSD DISPLAY MESSAGES

Message: **VSD SHUTDOWN - REQUESTING FAULT DATA**

This shutdown is initiated when the #53 to #16 circuit has been interrupted, and the control panel has not yet received the cause of the fault over the serial link. Whenever the VSD initiates a fault, it first opens the IIS relay in the VSD (between #53 and #16). The VSD then sends a message serially to the ACC, detailing the cause of the fault. Since the communications link loop is initiated every two seconds, the message should appear for just a few seconds and then be replaced with a VSD Fault message.

Message: **INVERTER INITIATED STOP FAULT**

Whenever the VSD initiates a fault, it first opens the IIS relay in the VSD (between #53 and #16). It then sends a message serially to the ACC, detailing the cause of the fault. If this #53 to #16 circuit ever opens without receiving an accompanying cause for the trip over the serial link (within 11 communication tries, approximately 22 seconds) this message will be displayed. Loose wiring is often the cause of this problem. Check the #1 to #53 horseshoe jumper in the panel and all other wiring involving #53 and #16.

Message: **START SEQUENCE INHIBITED BY VSD**

This shutdown will occur if a VSD fault takes place during the "Start Sequence Initiated" period. The chiller is inhibited from entering the starting sequence during the time period that a VSD fault occurs. When the VSD fault is cleared the start sequence will resume.

Message: **PHASE A (OR B,C) OVERCURRENT FAULT**

This shutdown is generated by the VSD if the motor current exceeds a given limit. The motor current is sensed

by the Current Transformers on the VSD output pole assemblies and the signals are sent to the VSD logic board for processing. Maximum instantaneous permissible currents are:

| | | |
|------------|---|-----------|
| 351/292HP | = | 771 Amps |
| 503/419HP | = | 1200 Amps |
| 790/658HP | = | 1890 Amps |
| 1100/900HP | = | 3093 Amps |

If an overcurrent trip occurs, but the chiller restarts and runs without a problem, the cause may be attributed to a voltage sag on the utility power feeding the VSD that is in excess of the specified dip voltage for this product. This is especially true if the chiller was running at, or near, full load. If there should be a sudden dip in line voltage, the current to the motor will increase, since the motor wants to draw constant horsepower. The chiller vanes cannot close quickly enough to correct for this sudden increase in current, and the chiller will trip on an overcurrent fault. Contact YORK factory service if this is confirmed to be a problem.

If the chiller will not restart, but keeps tripping on this same shutdown, an output pole problem is the most likely culprit. Check that both red LEDs are illuminated on each of the pole assemblies. Also, check for output short-circuits using an ohm-meter set to the minimum ohms scale. Measure from T1 to the Positive Bus and from T1 to the Negative Bus, checking with the ohm-meter in both directions. Repeat this same check for T2 and T3.

If no short circuits are discovered in the output poles, it is also possible you have a VSD logic board problem. This is especially true if the trip occurs during startup, before the motor begins to turn. If this is the case, it is possible to monitor the motor current during startup on the logic board. Using an oscilloscope, connect the ground clip to the GND test point on the board. Connect the probe tip to the top of one of the three CT terminating resistors R1, R2 or R3. If you find that the trip occurs, and no signal at all appears at the input, it is definitely a logic problem. If you do not have access to an oscilloscope, and the problem fits this description exactly, you may want to replace the VSD logic board and see if this corrects the problem.

Message: **PHASE A (B,C) GATE DRIVER FLT**

A second level of current protection exists on the VSD driver boards themselves. The collector-to-emitter saturation voltage of each IGBT is checked continuously while the device is being gated on. If the voltage across the IGBT is greater than a set threshold, the IGBT is gated off and a shutdown pulse is sent to the VSD logic board shutting down the entire VSD system. To diagnose the problem, first check the LED's on the gate driver board on the phase indicated in the message. Usually one of

the two LED's will be out. This clearly points to a bad gate driver, and requires replacement of the complete pole assembly for that phase. If both LED's are out, check for 120VAC at the 2-pin connector to the gate driver. If 120VAC is present, both LED's should be lighted. If both LED's are lit, and the problem repeatedly occurs in one phase, swap all three pole cables at the logic board J8, J9, and J10. Plug A into B, B into C, and C into A. If the display now reports a trip in a different phase, the problem is either in the pole or in the cable that feeds the pole from the VSD logic board. If the display continues to report a gate driver FLT in the same phase, even with cables swapped, the problem is in the logic board. Once you have finished troubleshooting, **be sure to put all of the cables back into their original mating connectors**. Also, be aware that a gate driver fault can be initiated when the VSD is not running.

Message: SINGLE PHASE POWER SUPPLY

This shutdown is generated by the SCR Trigger control and relayed to the VSD logic board to initiate a system shutdown. The SCR Trigger control uses circuitry to detect the loss of any one of the three input phases. The trigger will detect the loss of a phase within one half line cycle of the phase loss. This message is also displayed every time power to the VSD is removed or if the input power dips to a very low level. Usually it indicates that someone has opened the disconnect switch.

Message: HIGH PHASE A (B,C) HEATSINK TEMP

This shutdown will occur if the heatsink temperature exceeds 158°F on any of the output pole assemblies. This shutdown requires a manual reset via the Reset push-button on the VSD logic board. This shutdown will seldom occur, since in most cases where the coolant temperature has risen abnormally, the VSD will trip on "Ambient Temperature" (140°F) before the heatsinks can reach 158°F. If this message does occur, make certain you have an adequate level of coolant, check to be sure the cooling pump is operating when the unit is running and check the strainer in the primary of the heat exchanger for clogs and silt. If no cause is found, the culprit may be a bad temperature sensor on an output pole assembly. Using an ohm-meter check the resistance of the thermistor at plug P2 on the VSD logic board. The thermistor resistance should be 10K ohms at 77°F and a resistance vs. probe temperature chart is shown below.

| Temp. Deg. F | 32 | 50 | 59 | 77 | 100 | 115 | 140 |
|--------------|----------|-------|-------|-----|------|------|------|
| Resistance | Infinite | 19.9K | 15.7K | 10K | 5.8K | 4.2K | 2.5K |

Message: HIGH CONVERTER HEATSINK TEMP

Reference "High Phase A (B,C) Heatsink Temp" above for the troubleshooting procedure. The thermistor sensor is located on the AC to DC SCR/Diode semi-converter heatsink. This shutdown requires a manual reset via the Reset push-button on the VSD logic board.

Message: 105% MOTOR CURRENT OVERLOAD

This shutdown is generated by the VSD logic board and it indicates that a motor overload has occurred. The shutdown is generated when the VSD logic board has detected that at least one of the three output phase currents has exceeded 105% of the programmed 100% job full load amps (FLA) value for more than 7 seconds. The 100% job FLA setpoint is determined by adjustment of the FLA trimpot on the VSD logic board. The 100% job FLA setpoint may be viewed by pressing the "Options" key. This shutdown requires a manual reset via the Reset push-button on the VSD logic board.

Message: BUS OVER-VOLTAGE FAULT

The VSD's DC link voltage is continuously monitored and if the level exceeds 745 VDC, a Bus Over-Voltage shutdown is initiated. If this shutdown occurs, it will be necessary to look at the level of the 460 VAC applied to the drive. The specified voltage range is 414 to 508. If the incoming voltage is in excess of 508, steps should be taken to reduce the voltage to within the specified limits.

Message: MAIN BOARD POWER SUPPLY

This shutdown is generated by the VSD logic board and it indicates that the low voltage power supplies for the logic boards have dropped below their allowable operating limits. The power supplies for the logic boards are derived from the secondary of the 120 to 24 VAC transformer (Fig. 2) which in turn is derived from the 480 to 120 VAC control transformer (Fig. 1). This message usually means that power to the VSD was removed. If this was not the case, check the DC voltage test points on the VSD logic board at TPC (+15V), TPD (+10V), TPE (+5V), TPF (+7.5V) and TPG (-15V) with respect to TPH (Ground). If any of these voltages are incorrect, replace the VSD logic board.

Message: LOW DC BUS VOLTAGE FLT

If the DC link drops below 500 VDC (or 414 VDC for 50 HZ), the drive will initiate a system shutdown. A common cause for this shutdown is a severe sag in the incoming power to the drive. Monitor the incoming three

phase AC line for severe sags and also monitor the DC link with a digital meter. If the AC line or the DC link voltage is not dropping, check the wiring and connections from the DC link to the Voltage Isolator Board (wires 224, 225 and 226), and from this board to the VSD logic board 221, 222 and 223). Also check the associated connectors. If no problem is found, try replacing the Bus Isolation board (031-01624) and the VSD logic board.

Message: BUS VOLTAGE IMBALANCE FAULT

The DC link is filtered by many large, electrolytic capacitors which are rated for 450 VDC. These capacitors are wired in series to achieve a 900 VDC capability for the DC link. It is important that the voltage be shared equally from the junction of the center, or series capacitor connection, to the negative bus and to the positive bus. This center point should be approximately $\frac{1}{2}$ of the total DC link voltage. Verify the problem truly exists using a pair of digital meters, measuring from the series capacitor connection point to the positive bus, and from the series capacitor connection point to the negative bus. When the precharge relay engages, both voltage readings should come up together, and be approximately equal. If you find the voltages are equal, you likely have a problem with the bus isolator board, the VSD logic board or the wiring/connectors between them. Check the voltages at the input to the VSD Logic board, J3 pin 1 to J3 pin 2 and J3 pin 2 to J3 pin 3. The voltages should be approximately equal. If they are not, the likely cause is a bad isolator board, or a loose connection. If they are balanced, the VSD logic board should be replaced.

Most actual bus voltage imbalance conditions are caused by a shorted capacitor, or a leaky or shorted IGBT transistor in an output phase bank assembly. In order to check for these conditions, the laminated bus structure connecting the output phase banks together must be removed. Then connect a 12 VDC source (such as a battery charger used to charge automobile batteries) and apply 12 VDC between the positive bus and negative bus plates on each output pole assembly while measuring the voltage from center to plus, and center to minus. The bank which is causing the imbalance will be evident via unequal voltage readings. Replace the appropriate output phase bank assembly.

Message: HIGH AMBIENT TEMPERATURE FLT

The ambient temperature monitored is actually the temperature detected by a component mounted on the VSD logic board. The high ambient trip threshold is set for 140°F. Some potential causes for this shutdown are: internal VSD fan failure, VSD water pump failure or an entering condenser water temperature which exceeds the allowable limit for the job. Additional causes for the shutdown include:

- **Plugged Strainer** – The standard 1.5" Y-Strainer contains a woven wire mesh element with 20 stainless-steel wires per inch. This has been found to work adequately in most applications. Some users may have very dirty condenser water which can cause the strainer to plug. Locations with special conditions may want to consider a dual strainer arrangement with quarter turn valves, to permit cleaning of one strainer with the unit still on-line.
- **Plugged Heat-Exchanger** – In cases where the strainer plugs frequently, the heat-exchanger eventually may plug or become restricted to the point of reduced flow. At this point we suggest you back-flush the heat-exchanger by reversing the two rubber hoses which supply condenser water to/from the heat-exchanger. If the rust or sludge cannot be back-flushed, you may need to replace the heat-exchanger.
- **Low Condenser Flow** - The VSD system requires 8 feet of pressure drop across the heat exchanger to maintain adequate GPM. If the pressure drop is less than 8 feet, it will be necessary to correct the flow problem, or add a booster pump as is applied on retrofit chillers.

Message: INVALID CURRENT SCALE FAULT

The J1 connector on the VSD logic board contains jumpers along with wires from the output CTs. Since the part number of the logic board is the same on all horsepower sizes, the jumpers tell the logic board the size of the VSD being employed in order to properly scale the output current. If the jumper configuration is found by the logic to be invalid, the system will be shut down and the above message will be generated. The proper jumper configuration is shown on the wiring label for the VSD.

Message: LOW (CONV, OR PHASE A,B,C) HEATSINK TEMP.

A heatsink temperature sensor indicating a temperature below 37°F will generate a shutdown and display this message. In most cases the problem will actually be an open thermistor or broken wiring to the thermistor. The normal thermistor resistance is 10K ohms at 77°F. Check the circuit for continuity at VSD logic board plug J2. Also, make certain one side of the circuit is not shorted to the cabinet. Sometimes a thermistor wire can be pinched between the heatsink and the cabinet.

Message: OUTPUT CURRENT IMBALANCE

Normally the three phases of output current will be closely balanced since the voltage being applied to the motor is derived from the same DC Link voltage and the output transistors all switch in an identical pattern. Thus most imbalances will be due to variations in the motor wind-

ings, which may be as high as 8% typically. If this shutdown should occur, first check the log of output currents in each phase from the history display. Then measure the actual motor currents with a digital meter. If the imbalance is real, you are likely facing a pole problem. However, in most cases you will find the measured currents are false, and the problem is likely due to a bad CT, wrong value CT, faulty wiring to the CT, or a bad VSD logic board. Using a DVM set to the AC voltage scale, connect one lead to the GND test point on the board. Connect the remaining lead to the top of each of the three CT terminating resistors R1, R2 and R3. Measure the three voltages at the top of each resistor. If they are equal, the problem is the logic board.

Message: PRECHARGE BUS V IMBALANCE

This situation is identical to the above shutdown, "Bus Voltage Imbalance Flt", except that it has occurred during the precharge period which begins during pre-lube.

Message: PRECHARGE LOW VOLTAGE FAULT

During precharge the DC Link must be equal to or greater than 50 VDC (41 VDC for 50 HZ) ½ second after the precharge relay is energized. The unit is shut down and this message is generated if this condition is not met. If this shutdown occurs, check the precharge relay, pre-charge resistors, and the wiring between the VSD logic board and the pre-charge relay.

Message: PRE-CHARGE HIGH VOLTAGE FAULT

During precharge, the DC Link must reach at least 500 VDC (414 VDC for 50 HZ) 15 seconds after the pre-charge relay is energized. The unit is shut down and this message is generated if this condition is not met. If this shutdown occurs, check the pre-charge relay, pre-charge resistors, and the wiring between the VSD logic board and the pre-charge relay.

Message: PRE-CHARGE FAULT LOCKOUT

If the unit fails to make pre-charge the pre-charge relay will drop out for a time period of 10 seconds during which time the units fan(s) and water pump(s) shall remain energized in order to permit the pre-charge resistors to cool. Following this 10-second cool-down period pre-charge shall again be initiated. The unit shall attempt to make pre-charge three consecutive times. If the unit fails to make pre-charge on three consecutive tries, the unit will shut down, lockout, and display this message. In order to initiate pre-charge again, the Micropanel's rocker switch must first be placed into the STOP/RESET position.

Message: PWM COMMUNICATIONS FAULT

This shutdown is generated if a communications prob-

lem occurs between the two microprocessors on the VSD logic board. If this shutdown should occur, replace the VSD logic board.

Message: RUN RELAY FAULT

Redundant run signals are generated by the Micropanel, one via wire #24 and the second via the serial communications link. Upon receipt of either of the two run commands by the VSD logic board, a 5-second timer will commence timing. If the missing run command is not asserted within the 5-second window the unit will shut down and the Micropanel will display the message "Run Relay Fault". This shutdown could occur if there is a problem with the wiring between the control panel and the VSD. Check the #24 to #25 horseshoe jumper in the panel, and all other wiring involved in energizing #24 in the VSD. Also check to ensure that the serial communications wiring between the VSD and the Micropanel is connected properly.

Message: SERIAL RECEIVE FAULT

This message is generated when communications between the ACC and VSD logic is disrupted. Check the shielded cable between J11 on the VSD logic and J8 on the ACC board. Check for continuity and also check to see that none of the conductors are shorted together or shorted to ground. The terminal block in the lower left corner of the VSD cabinet serves as a junction point for this cable, and it is possible for strands of wire to bridge across the terminals at this location. If all wiring is intact, this problem may also be caused by electrical noise. Make certain the shield for this cable is tied to chassis ground at the control panel end only via a green chassis ground screw. If all of this has been done and communications can never be established, even at power-up, you may have a bad communications driver on either the VSD logic or the ACC. Change out both the ACC and VSD logic boards. If the Serial Receive fault problem only occurs intermittently during times when the unit is running, the culprit could be electrical noise. At times ferrite beads placed over the shielded cables will attenuate high frequency noise sufficiently. The part number for these ferrite beads may be found on the VSD parts list.

Message: VSD INITIALIZATION FAILED

At power-up, all the boards go through a process called initialization. At this time, memory locations are cleared, jumper positions are checked, and serial communications links are established. There are many causes for an unsuccessful initialization. The following check list should aid in determining why initialization has not completed:

- The Micro-Panel and the VSD must be energized at the same time. The practice of pulling the fuse in the control panel to make wiring changes will create a

problem. Power-up must be done by closing the main disconnect on the VSD cabinet with all fuses in place. Be sure you do not have a blown fuse, causing loss of power to the VSD logic board.

- The EPROMs must be correct for each board, and they must be correctly installed. There are a total of seven (7) EPROMs in each VSD - Micropanel system. These EPROMs are created as a set, and cannot be intermixed between earlier and later styles of units. Also, the ACC EPROM must be in the ACC board, and the Micropanel EPROM in the Microboard, etc. All pins must be properly inserted into the EPROM sockets.
- Serial data communications must be established. See the write-ups for the messages, "Serial Receive Fault" and "FLTR Serial Receive Fault". If communication among the VSD logic, the filter logic, the ACC and the Microboard does not take place at initialization, the "VSD Initialization Failed" message will occur before any other message can be generated. You can check to see that serial communications has been established by pressing the OPIONS key and noting the %Job FLA value displayed. A zero displayed value for this parameter (and all other VSD parameters) indicates a serial communications link or EPROM problem.
- If the IEEE-519 Filter option is included, make sure the '519' Logic board is not in continuous reset. This will be evidenced by the LEDs on the filter logic board alternately blinking. This situation is addressed elsewhere in this literature. To rule out the '519' filter as the cause of initialization failure, you can disconnect the filter by switching the filter logic board's SW1 switch to the OFF position, and removing the 16 wire ribbon cable between the '519' logic and VSD logic boards.

Message: **FLTR HEATSINK OVERTEMP FLT**

The '519' filter power assembly has one heatsink thermistor on the 351 & 503 HP units, and two heatsink thermistors on the 790 HP units. If the temperature on any heatsink exceeds 167 °F, the unit will shut down, and require a manual reset by pressing the "Overtemp Reset" pushbutton located on the Filter Logic board. This message is usually an indication that the level of coolant in the closed loop system on the back of the VSD is low. If the coolant level is found to be adequate, using an ohmmeter, check the resistance of the thermistor at plug P6 (and P13 for the 790/658 Hp) on the filter logic board. The thermistor resistance should be 10K ohms at 77°F and a resistance vs. probe temperature chart is shown below.

| | | | | | | | |
|--------------|----------|-------|-------|-----|------|------|------|
| Temp. Deg. F | 32 | 50 | 59 | 77 | 100 | 115 | 140 |
| Resistance | Infinite | 19.9K | 15.7K | 10K | 5.8K | 4.2K | 2.5K |

Message: **FLTR BUS OVER-VOLTAGE FLT**

The harmonic filter's DC link voltage is continuously monitored and if the level exceeds 860 VDC, a Filter Bus Over-Voltage shutdown is initiated. Keep in mind that the harmonic filter has its own DC bus as part of the filter power assembly, and this DC Link is not connected in any way with the drive's DC Link and Laminated Bus. If this shutdown occurs, it will be necessary to look at the level of the 460 VAC applied to the drive. The specified voltage range is 414 to 508. If the incoming voltage is in excess of 508, steps should be taken to reduce the voltage to within the specified limits. The cause of this message will typically be high line voltage, or a surge on the utility supply.

Message: **FLTR LOW BUS VOLTAGE FLT**

The harmonic filter dynamically generates its own filter DC link voltage by switching its IGBT's. This DC level is actually higher than the level one could obtain by simply rectifying the input line voltage. Thus the harmonic filter actually performs a voltage "boost" function. This is necessary in order to permit current to flow into the power line from the filter when the input line is at its peak level. This particular shutdown and its accompanying message is generated if the filter's DC link voltage drops to a level less than 60 VDC below the filter DC link voltage setpoint. The filter DC link voltage setpoint is determined by the filter logic board via the sensing of the three phase input line-to-line voltage. This setpoint is set to the peak of the sensed input line to line voltage plus 32 volts, not to exceed 760 volts and varies with the input line to line voltage. If this shutdown occurs occasionally, the likely cause is a severe sag in the input line voltage. A power monitor should be installed to determine if a power problem exists.

Message: **FLTR PHASE A (B,C) OVERCURRENT**

The maximum instantaneous harmonic filter current is monitored and compared against a preset limit. If this limit is exceeded, the unit is shut down and this message is generated. The filter current is monitored using two DCCTs and these signals are processed by the filter logic board. The preset limits are as follows:

| | | |
|-------------|---|-----------|
| 351/292 HP | = | 378 Amps |
| 503/419 HP | = | 523 Amps |
| 790/658 HP | = | 782 Amps |
| 1100/900 HP | = | 1225 Amps |

If you experience this shutdown and the VSD auto-restarts and continues to run properly with the filter operating, it is likely the filter tripped on Overcurrent due to a sag or surge in the voltage feeding the chiller. If this happens frequently, contact YORK factory service for suggestions on how to improve the situation. If this message re-occurs, preventing the unit from being restarted, you will need to check the filter power assembly for shorted transistors by measuring from wires 519, 518, and 517

to the filter's positive bus, checking in both directions - and from 519, 518, and 517 to the filter's negative bus in both directions. None of the readings should be less than 5 ohms.

Message: FLTR PHASE LOCK LOOP FLT

This shutdown indicates that a circuit called a "phase locked loop" on the filter logic board has lost synchronization with the incoming power line for a period of time. This is normally an indication that one of the filter's incoming power fuses is blown. Check filter power fuses 11FU, 12FU and 13FU if this shutdown occurs. If the fuses are OK, check the output of the line voltage isolation board at J5, pins 1,2,and 3 on the filter logic board. With 480 VAC present on the input to the line voltage isolation board, 1.7 VAC should be present from pins 1 to 2, pins 2 to 3, and pins 3 to 1 at J5 on the filter logic board.

Message: FLTR POWER SUPPLY FLT

This shutdown indicates that the low voltage power supplies on the filter logic board have dropped below their permissible operating voltage range. The filter logic board receives its power from the VSD logic board via the ribbon cable which connects the two. The power supplies for the logic boards are in turn derived from the secondary of the 120 to 24 VAC transformer (Fig. 2) which in turn is derived from the 480 to 120 VAC control transformer (Fig. 1). If this shutdown occurs, check the CR10 LED, labeled "Power Supply OK". If this is not illuminated, check the ribbon cable connecting the filter logic board to the VSD logic board. If the CR10 LED is illuminated, you likely have a faulty Filter logic board, and it needs to be replaced.

Message: FLTR BUS V IMBALANCE FLT

The filter DC link is filtered by large, electrolytic capacitors which are rated for 450 VDC. These capacitors are wired in series to achieve a 900 VDC capability for the DC link. It is important that the voltage be shared equally from the junction of the center or series capacitor connection, to the negative bus and to the positive bus. This center point should be approximately $\frac{1}{2}$ of the total DC link voltage. Verify the problem truly exists using a pair of digital meters, measuring from the series capacitor connection point (wire 530A) to the positive bus (wire 531A), and from the series capacitor connection point to the negative bus (wire 529A). When the filter pre-charge relay engages, both voltage readings should come up together, and be approximately equal. If you find the voltages are equal, you likely have a problem with the filter bus isolator board, the filter logic board or the wiring/connectors between them. Check the voltages at the input to the filter logic board, J5 pin 4 to J5 pin 5 and J5 pin 5 to J5 pin 6. The voltages should be approximately equal. If they are not, the likely cause is a bad isolator

board, or a loose connection. If they are balanced, the filter logic board should be replaced. If the voltages do not come up equally, check the wiring between the bleeder resistors 14RES and 15RES and the filter phase assembly. Also check the value of these resistors. They should be 3000 ohms nominally. If no problem can be found by performing these steps, replace the filter phase assembly.

Message: FLTR PCHARGE LOW BUS V FLT

During pre-charge the filter's DC link must be equal to or greater than 50 VDC (41 VDC for 50 HZ) 1/10 second after the filter pre-charge relay is energized. The unit is shut down and this message is generated if this condition is not met. If this shutdown occurs, check the filter pre-charge relay, filter pre-charge resistors, and the wiring between the filter logic board and the filter pre-charge relay.

Message: FLTR PCHARGE HI BUS V FLT

During pre-charge, the filter's DC Link must reach at least 525 VDC (425 VDC for 50 HZ) 5 seconds after the filter pre-charge relay is energized. The unit is shutdown and this message is generated if this condition is not met. If this shutdown occurs, check the filter pre-charge relay, filter pre-charge resistors, and the wiring between the filter logic board and the filter pre-charge relay.

Message: FLTR OVERLOAD FLT

The three phases of RMS filter current are monitored and if the level of any one of the three phases continuously exceeds a given threshold for seven seconds, unit shutdown is initiated and this message is displayed. The maximum permissible continuous RMS current ratings for the harmonic filters are as follows:

| | | |
|-------------|---|----------|
| 351/292 HP | = | 128 Amps |
| 503/419 HP | = | 176 Amps |
| 790/658 HP | = | 277 Amps |
| 1100/900 HP | = | 385 Amps |

Message: FLTR HIGH TDD FLT

This shutdown indicates that the filter is not operating correctly and the input current to the VSD/filter system is not sinusoidal. This shutdown will occur if the TDD exceeds 25% continuously for 45 seconds. TDD is an acronym for Total Demand Distortion, a term defined by the IEEE Std 519-1992 standard as "the total root - sum - square harmonic current distortion, in percent of the maximum demand load current (15 or 30 min demand)". In the filter option supplied by York, the displayed TDD is the total RMS value of all the harmonic current supplied by the power mains to the VSD system divided by the job FLA of the VSD, in percent. The harmonic filter option was designed to provide an input current TDD level of 8% or less for the VSD system. A standard VSD less the optional filter typically has an input current TDD level

on the order of 28 - 30%. Causes for this shutdown are numerous but it would most likely be caused by a bad filter logic board.

Message: WARNING - FILTER DATA LOSS

This message is displayed if the communications link between the VSD logic board and the filter logic board, or the communications link between the filter logic board and the ACC board is interrupted. This message can also occur as a background message when the chiller is running. When this message is displayed all filter related parameters are replaced with X's. If communications is re-established, the message will disappear, and normal values will again be displayed. If this problem is encountered, the ribbon cable connecting the VSD logic board to the filter logic board should be checked. The integrity of the shielded communications cable between the filter logic board and the ACC board should also be checked. Finally, replacement of the filter logic board, the ACC board and the VSD logic board should be tried, one board per try.

Message: FILTER DCCT 1 (OR 2) ERROR

During initialization, with no current flowing through the DCCT's, the DCCT output voltages are measured and compared with a preset limit via the filter logic board. If the measured values exceed the preset limits, the DCCT's are presumed to be bad and this shutdown will be generated. If this shutdown should occur, check the signal output from the DCCT's by measuring the voltage at filter logic board plug J3 pin 5 and J3 pin 12 with respect to signal ground (J5 pin 2) with the unit stopped. Both voltages should be approximately 0 VDC. These DCCT's are powered from +15 VDC supplies via the filter logic board. Check for the presence of the +15 VDC power supplies by measuring the voltages at filter logic board J3 pins 6 and 10 with respect to signal ground (J5 pin 2). Check for the presence of the -15 VDC power supplies by measuring the voltages at filter logic board J3 pins 7 and 11 with respect to signal ground (J5 pin 2). If the DCCT output is not zero and the + 15 volt supplies are present, replace the offending DCCT. If no problem with the DCCT output voltage is found, replace the filter logic board.

Message: FLTR RUN RELAY FLT

When a digital run command is received at the filter logic board from the VSD logic board via the 16 position ribbon cable, a 1/10 second timer is begun. A redundant run command must also occur on the serial data link from the VSD logic board via the ribbon cable before the timer expires or the unit will be shut down and this message will be displayed. If this shutdown occurs, check the integrity of the 16 wire ribbon cable installed between the VSD logic board and the filter logic board. If the prob-

lem persists, replace the VSD logic board and if the problem remains, the filter logic board.

The Following Messages Pertain to Original and "Style A" Units Only:

Message: FLTR CO-PROCESSOR FLT

This message indicates a clock timing problem has occurred on the filter logic board. If this occurs more than once, replace the filter logic board.

Message: FLTR SW-BACKGRND FLT

(or, **FLTR SW-PRECHARGE LOOP FLT** on early units)

This message means the software did not complete the program loop in the allotted time. This is a watchdog timer function on the Filter Logic board.

Message: FLTR +15 V POWER SUPPLY FLT

This message indicates a failure of a low voltage DC regulator on the filter logic board.

Message: FLTR -5 V POWER SUPPLY FLT

This message indicates a failure of a low voltage DC regulator on the filter logic board.

Message: FLTR -15 V POWER SUPPLY FLT

This message indicates a failure of a low voltage DC regulator on the filter logic board.

Message: FLTR THERMISTOR SUPPLY FLT

This message indicates a failure of a low voltage DC regulator on the filter logic board.

Message: FLTR LOW HEATSINK TEMP FLT

The temperature as measured by the filter's thermistor (2 thermistors on 790 HP) has dropped below 37°F. This may be caused by an unplugged thermistor, loose connections, or a wire pinched against the chassis. Normal thermistor value is 10K ohms at 77°F. An open circuit will simulate a temperature of 32°F.

Message: FLTR A/D CONVERTER FLT

The '519' Filter logic does a check where it looks at ground and converts the voltage to a digital value. This level should be zero. However, if there is electrical noise present on ground, this value will be greater than zero, and this fault message may appear. Locations experiencing this nuisance message can by-pass this check by installing a special EPROM in the '519' filter logic board. Contact YORK factory service for this EPROM.

Message: FLTR INPUT FREQUENCY FLT

The input frequency as measured by the Filter Logic, is outside the acceptable range of +/- 1 Hertz.

Message: FLTR HIGH INPUT V FLT

The input voltage as measured phase to ground, and in "peak" volts, must not exceed 424.6 Volts peak. If exceeded for over 30 seconds, this message will be generated. The normal cause will be a high utility voltage, greater than 500 VAC on a 460 VAC system, for example. Since our systems are designed to operate up to 508 VAC, if this becomes a source of nuisance trips, contact the YORK factory service group for advice.

Message: FLTR TRIANGLE WAVE FLT

This message was intended as a check of the '519' logic board's internal triangle waveform generator. However the accuracy of the measuring circuit on the board can have as much error as the generator it is trying to measure, resulting in nuisance shutdowns. If this message occurs repeatedly, it can be corrected by installing a special EPROM. Contact YORK factory service in this case.

Message: FLTR SERIAL RECEIVE FAULT

is a message which would occur on some early installations with the IEEE-519 Filter option. It is related to the level of electrical noise picked up on the serial communications lines. We have corrected for this by a modification to the filter logic board. Filter logic boards (P/N 031-01632-002 or 001) of a "G" revision or later should not experience this problem.

Message: FLTR PHASE ROTATION FLT

The filter determines phase rotation upon receiving a run signal. Once determined, the phase rotation must remain constant for 30 line cycles. If not, this message will be generated. The most likely cause of this message would be an interruption in utility power supplying the VSD.

Message: FILTER DSP FAULT

On initialization, the Filter logic writes all zero's to DSP memory, and then writes all one's to the same memory. If any error occurs during read-back, this message is generated. This would indicate a failure of the Filter Logic board.

Message: FILTER MEMORY FAULT

On initialization, the Filter logic writes all zero's to External memory, and then writes all one's to the same memory. If any error occurs during read-back, this message is generated. This would indicate a failure of the Filter Logic board.

START-UP PREPARATIONS

Make certain the correct EPROMs are all installed in the proper locations by referring to the EPROM Reference List in this publication. Be sure the dimple in the end of the chip is oriented in the correct direction. Also, be sure the TM/Non-TM jumper is cut on the Microboard.

Apply power to the VSD, and check the front panel display. After a few seconds you should get the message, "System Ready to Start". If you do not, turn off power, wait five minutes for the voltage to discharge, verify voltage is no longer present, and then double check all wiring and connections.

At this point, start-up is as simple as one, two, three...

1. If initial power-up is successful, set the Full Load Amps (FLA) on the VSD by pressing the "Options" key. You will see a display of "VSD 100% Job FLA = (some value) Amps". Adjust this value to the correct FLA for your installation by turning the small trimpot located in the upper-middle area of the VSD logic board inside the VSD. Clockwise will increase the FLA. You will need to alternate between making an adjustment, and checking the value on the display, until the displayed value is correct within one amp. UL requires that the FLA be set by a hardware adjustment within the VSD, and cannot be software dependent. On later-built units, this pot is a multi-turn pot to aid in this adjustment.
2. Next fill the coolant loop using York's pre-mixed solution, part number 013-02987-000. Pour the solution into the top of the header pipe until the level is within an inch of the top. Then run the pump by unplugging connector P2 on the VSD logic board. The level in the fill-pipe will drop quickly. Add more coolant so the level is maintained at one inch from the top of the pipe. Continue to run the pump for 15 minutes, adding more coolant as needed, then reinstall P2, make certain the level is one inch from the top, and install the pipe plug in the header pipe using teflon tape to assure coolant does not evaporate through the pipe threads.
3. The vane pot is now automatically calibrated by the micro-panel. The pot itself was previously installed, and should have been set so that neither end of travel runs up against either end-stop of the pot. The closed end of the pot should be set for a feedback voltage somewhere between 0.3 and 0.7 VDC, as measured from the wiper (white wire) to common (black wire). The full-open feedback voltage will then be some greater value. For example, you might get a range of 0.54 VDC closed, to 1.12 VDC at full open. This range of voltage will be scaled by the microcomputer to a range of 0% to 100%. The computer will remember the voltage that corresponds with the percentage of vanes.

This scaling is accomplished by an automatic calibration routine in the micro-panel. To run the auto-calibration do the following:

- Enter an Access Code of 1380
- Change the operating mode of the panel to the VSD Service Mode (not Service mode)
- Check to ensure that the panel is in the Program Mode
- Press the Open key.
- The display will show, "Calibration in Progress - Vanes Opening"
- The vanes will run to the full open position and stop.
- After a few seconds the display will show, "Calibration in Progress - Vanes Closing"
- The vanes will run to the full closed position and stop.
- The display should show, "Calibration Successful"
- If so, press the Enter key to accept this calibration. Calibration is not accepted unless the Enter key is depressed.
- If "Calibration Successful" is not achieved, press the cancel key to abort the procedure.

This completes the extra start-up procedures which are required for chillers with the VSD. If any difficulty is encountered, refer to the other sections of this publication.

VSD FREQUENTLY ASKED QUESTIONS

Measured Amps at input to the VSD does not agree with rated FLA. The input current to the VSD will be considerably lower, compared to the output current. This is due to the power factor at the input to the VSD being greater than .95, and nearly unity when the IEEE-519 option is included. Chiller FLA must be measured at the motor terminals, where the power factor is the normal motor power factor. Use a true RMS reading meter to make these measurements.

Manual Speed Control is a bit more complicated than it was on earlier products. It first requires you go into the VSD Service mode. Once in the VSD Service mode, make certain you are NOT in program by pressing the program button and watching the display. With the panel NOT in program, you can adjust the frequency setpoint using the increment and decrement keys which are combined with the vanes open and closed buttons. You can also select fixed 60HZ by pressing the 60HZ key. The VSD will begin to change speed, moving toward the manual setpoint you entered. It may take some time to attain the programmed frequency. To exit the manual VSD speed mode, press the Auto key. Be sure the unit is in Auto speed mode before exiting the VSD service mode, otherwise the unit will stay in the manual VSD speed mode after exiting the VSD service mode.

Manual Vanes are controlled as before in the Service Mode (not VSD service). The panel must NOT be in program mode, or these keys will program the Turbo Guard Boost Pump.

Retrofit DV/DT Network is a 7 inch by 7 inch accessory box which connects to the motor leads at the motor terminal box on retrofits. This delta connected filter network suppresses excessively large and fast rising voltages that would otherwise be applied to the motor due to the combination of long wiring and the use of a PWM inverter. This DV/DT network must be connected directly across the motor windings.

On all VSD units, this same circuit is located on the red fiberglass vertical support located just to the left of the pole assemblies. Since this filter is already present inside the cabinet on all VSD units, some installers have questioned whether the internal circuit must be disabled when using the terminal box mounted accessory. The answer is no - you do not need to disconnect the filter inside the VSD cabinet.

Condenser Water Strainer is supplied on all installations to prevent plugging of the flat-plate heat exchanger on the rear of the VSD. This strainer contains a 1.5 inch diameter stainless steel wire mesh element. This mesh is a woven material containing 20 wires per inch. A few early shipments contained elements which used a steel cylinder with punched holes. These strainers may plug prematurely, and should be replaced by the woven wire type.

Anti-Recycle with VSD is now five (5) times in succession, followed by a ten minute wait. After ten minutes, you get five more successive starts. This is permitted on VSD units only, due to the low inrush current and reduced motor heating during inrush.

YT Condenser Transducer for VSD is now a 025-29148-009, which has a lower range of operation to address applications with low entering condenser water. Its range is 4 to 34 PSIA, with a proportional output of 0.5 to 4.5 VDC. The VSD software for YT chillers require the use of this transducer.

Auto-Calibration of the vane feedback potentiometer is difficult to recall without having a printed reference. Refer to item 3 of "Start-up Preparations" in this publication (page 22).

If the vane motor reverses direction prematurely, it is likely the voltage feedback has not changed enough during successive program loops. Likewise, if the vane motor gets to the full open position, and does not change direction, it is likely the voltage is still changing, even though the linkage is at the end of its travel. In some cases electrical noise may be present on the signal,

and the microprocessor is seeing this noise as a change in voltage. If you run into either of these situations, call YORK factory service.

Wire #61 in the Control Panel on YK chillers is wired differently when a VSD is applied. The vent line solenoid and the oil return solenoid are both tied together and energized by wire #61. The vent line solenoid is no longer on #34 when a VSD is applied. Output to wire #34 now energizes the liquid line solenoid (gear cooling) alone, and ONLY when the sump temperature rises above 140°F. Wire #34 now de-energizes when the sump drops below 135°F.

ACC print Map is a feature which allows printing a record of all surge points stored in the ACC battery backed memory. With a printer connected to the micro-board in the normal manner, you can enable this feature while in the VSD Service mode, by entering Program mode, and pressing the front panel "Print" key. The display will say, "Enable Map Print? NO; Restart Map? NO". Change NO to YES in both cases using the scroll key and pressing enter each time. The printer will begin printing the map. This can take quite a long time, and therefore we do not suggest you try this with the Weightronix printer due to its slow printing speed. If you wish to leave a printer connected and log new surge points as they occur, you can answer YES + NO to the above two questions. The printer will log all new points and will printout system data present at the time of each surge.

Stability Limit determines whether a surge is stored in the compressor map if the leaving water temperature is changing faster than the programmed rate. If a surge occurs, and the leaving water is within the window of +0.3°F to -0.8°F, it will not be mapped if the temperature is changing. The stability limit index normal value is 4500, but may be changed to a value between 1000 and 7000, and it is programmed in the VSD service mode by entering program mode and pressing the chilled liquid temps display key. Do not make changes unless directed to do so by YORK factory service.

Remote 1 to 11 Second Reset Pulse not working, is the result of this feature being removed, in favor of support for FAX4500. If you have an existing installation using the 1 to 11 second PWM control (or a card file), and you find this feature is not working, contact YORK factory service. We can supply special software to re-enable this function on early production units. This feature has been reinstated as a standard offer on "B" style VSD units.

Wire Ampacity to VSD, and VSD to Chiller – Power wires are sized at 1.25 times the full-load amps, plus oil pump amps and control transformer amps. Note this differs from the 1.38 multiplier used on earlier drives. VSD

to Motor wires need only be 1.25 times the motor FLA, since the oil pump and control power are not part of the equation at this point.

Surge Counter – The surge counter increments each time the ACC detects a chiller surge. It is not uncommon to receive a chiller with some number of surges recorded in memory. The only way to zero this value is to zero the B-RAM memory which stores the compressor surge map and other non-volatile data. Zeroing of the B-RAM generally is not done unless some condition has caused false data to be stored - see section titled "Zeroing B-RAM" below. Also, be aware it is not uncommon to find very high numbers of surges. We had one chiller which surged for two weeks, running 60 HZ, along with a fixed-speed chiller which was also surging due to tower problems. After two weeks, the customer decided it was time to fix the tower! In this case we logged over 18,000 surges.

Zeroing B-RAM – This memory, located on the ACC board, is maintained by an internal lithium battery. It stores the compressor surge map information, and other data such as the vane pot calibration. There are only two cases where the this memory should be cleared - when the chiller has been running and storing invalid surge information due to a mis-calibrated vane pot, and when the chiller has been running and storing invalid data due to a faulty condenser or evaporator transducer. Vane position and refrigerant pressures are the basis of the surge map, and if these values are false, the map created with false information will be a false map. Any other conditions which may be abnormal will only cause the chiller to run at an abnormal part of the map, but will still be valid data for the conditions. For example, if the cooling tower should by-pass water, causing a false high-head, the chiller will figure out the best mode of operation for these conditions, even though they are abnormal. When the problem with the tower is fixed, the chiller will determine a new optimum operation on a different part of the map. Neither set of stored values is incorrect. If the same tower problem ever develops again, the chiller will already know what to do. If you believe you need to zero the B-RAM, call YORK factory service for assistance.

DV/DT Snubber Network Leads Too Short – On some large motor terminal boxes there will be no location which permits the wires supplied to reach all three motor conductors. The instruction with the retrofit materials cautions not to lengthen these leads. It is acceptable to add 10" of wire, butt-spliced to each of these wires from the Snubber Network.

Isolation of Power Conduits – We no longer require a section of non-metallic conduit at entrance and exit to/

from the VSD as we did on previous products. If any customer or installer wishes to continue to follow this practice, we have no objections.

Wiring ACC to Power Supply Board in Control Panel

The ACC is powered by +30 VDC Unregulated from the control panel's power supply board. There are two connectors on this power supply which can furnish +30 VDC Unregulated. The plug designated in the retrofit drawings is sometimes already being used by the liquid level control. It is permissible to daisy chain off this same wiring, or you may elect to utilize the alternate +30 VDC Unregulated connection.

Retrofit Instructions – There are 3 drawings shipped with each retrofit kit. These drawings are:

- Vane Pot Installation and Set-Up
- Piping Installation
- Control Panel Retrofit

12 Lead Motor Wiring – We have received many questions about how to wire a twelve lead motor. Most of these motors actually have two sets of parallel windings, and therefore have two one's, two two's, etc. VSD's and Solid-State Starters are connected to the motor in the delta configuration, that is 1&6, 2&4, 3&5. The T1 lug will then have two one's and two sixes tied to it.

There were a few motors, made several years ago, which were numbered 1 through 12. These motors had the first set of wires marked 1 to 6. Numbering then continued, with the second 1 numbered 7, the second 2 numbered 8, and so on, up to 12. In other words, take the numbers above six, subtract 6 from the number, and re-label as the result.

Peak Input Voltage – The displayed value is the Phase to Ground voltage at the input to the drive in terms of peak voltage, as would be measured with an oscilloscope.

Phase to ground is normally the phase-to-phase voltage divided by the square root of three, or 265 VAC phase to ground, for a 460 VAC system. The peak value of the 265 VAC measurement is approximately that number times the square root of two, or 375 volts in this example.

KWH Meter Zeroing Procedure – This accumulator is reset by going into the "VSD Service Mode", making sure the panel is in "Program Mode", and pressing the "Operating Hours / Start Counter" button. The display will show, "Reset Hours? Y/N". Use the advance day / Scroll key to select "Y", and press "Enter".

Remote Setpoint Range – Note that 1 to 11 second temperature reset is not an offered feature in YT-VSD chillers prior to the B-Revision Units. In early YK, and in later "B-Revision" VSD chillers, the remote ranges are as follows:

| Microboard Jumpers Set | Temperature Range |
|------------------------|-------------------|
| Water, Non-TM | 38 - 70 |
| Water, TM | 40 - 60 |
| Brine, Non-TM | 10 - 45 |
| Brine, TM | 34 - 54 |

The remote reset feature may be added to early YT-VSD chillers by contacting YORK factory service for a software update.

Clock Chip & BRAM Chips – If you are familiar with the RTC Clock chip used on the control panel microboard, you may notice what appears to be clock chips on the ACC board and on the VSD logic board. These two boards contain similar black plastic chips which are battery backed random access memory (BRAM). They have a different number of pins from the RTC Clock chips, and cannot be replaced by the familiar clock chip.

Booster Pump on Retrofits – On retrofit installations, where the VSD is located away from the chiller shells, it is likely the condenser water to the VSD will be piped from the chiller, up to the ceiling, across some distance, and back down to the VSD. This piping (field supplied) is to be 1" rigid pipe, and may result in the inability to achieve 8 feet of pressure drop across the VSD heat exchanger. In this case a booster pump is necessary. This pump is to be field purchased, and selected for 10 GPM at 15 Feet of Head. We suggest a Grundfos Model UP26-96BF which is readily available and should meet your requirement. You will also need to purchase a pilot relay, which we suggest you wire in parallel with the oil pump contactor coil. The 120 VAC supply for the pump must come from an external source. Be certain to install a YORK suppresser across the coil of this pilot relay.

VSD on Generator Power – There is no special trigger board or other modification needed for backup generator application. We have several VSD installations running on generator power without difficulty. It is necessary that the generator's output voltage be maintained within the specified range of 414 to 508 VAC, and frequency be maintained within +/- 1 HZ (on 60 HZ applications). This is usually not a problem for most generators, since motor inrush is limited to less than 1X the Full Load Amps (FLA).

5 Sec. Ventline Timing Problem – Early Style “B” VSD software for YT chillers contained an error, where the ventline timer was 5 Seconds, rather than 5 Minutes. If you discover this problem, order a new 031-01676-003 EPROM. All EPROMs in stock are of a later revision.

Blown MOVs – The metal oxide varistors (MOVs) connected across the input to the VSD rectifier, are there solely to protect the VSD against any high voltage transients which could otherwise damage the VSD unit. If you find an MOV blown, or shorted, it is likely due to a voltage transient. More than one MOV blown is definitely due to a power surge.

Causes of Chiller Speed Not Reducing - The VSD will not reduce the motor speed until the leaving water temperature is within +0.3 to -0.8 of a degree from setpoint. Once in this window, the speed still cannot be reduced until the operation is deemed to be stable, based upon the vanes are not continually moving open and closed to maintain temperature. This hunting effect is normally due to one of the following:

- Chilled water and Condenser water flows are not at design GPMs.
- Return water temperature is varying due to 3-way valves or other system configuration, and the chiller is simply following changes in load.
- Vane stroke is too large. Remove the sensitivity jumper in the Micro-Panel. Also, check the vane motor to see that the fullest possible stroke is being utilized. Moving the vane motor arm pivot point closer to center, and extending the degrees of travel by adjusting the internal end stops, will reduce the amount of vane action for the same period of operation.

Failure to reduce speed may also be due to the system having been placed in Manual Speed when in VSD Service Mode. Other causes are a missing or disconnected wiring harness at ACC board J3, or a faulty ACC board itself.

Green LED on ACC Board – This LED will light if the system is in Manual, or if the chiller is running in current limit, or if the leaving water temperature rate of change is greater than that programmed by the stability limit function.

Not Detecting Surge – When “Surge” is detected, the ACC board will light the red LED on this board. Failure to light the red LED may be due to one of the following:

- Condition is “Low Load Rumble”, Not Surge - Low load rumble is a very noisy condition which is due to gas pulsations hitting the impeller wheel in a random fashion. System pressures and motor current may fluctuate in brief, random pulses, but this is not a surge. True surge will be characterized by a repeated howling sound, with pressure and motor current swinging in a cyclical manner.

- The wire harness connecting the ACC board J3 to the Micro-board may be missing or disconnected. This harness passes system pressure information to the ACC board.
- The ACC board may be defective.

Coolant Color Loss – The coolant normally has a pink or rose color when new. After several months of operation, this color may dissipate, and the coolant may appear almost colorless. This does not necessarily indicate a problem. Most colorless samples test above 1000 PPM nitrite, which is normal. There is no need to flush the system unless you find the coolant becoming opaque or cloudy. In this case we suggest you obtain a sample for analysis, then flush the system and install fresh coolant. The coolant must be changed every two years regardless of color or test results.

Retrofit DV/DT Network Smoking – The retrofit DV/DT network, housed in a 7” by 7” perforated metal box, can emit smoke if the resistors inside should be located too near to the red fiberglass back-wall. These resistors can reach 300°F, and if positioned too close to the fiberglass, will cause the fiberglass material to smoke. Re-position the resistors away from the fiberglass, and be certain the resistors are also spaced away from each other.

VSD Circuit Breaker Tripped – Normally any major failure within the VSD will result in blowing the semi-conductor fuses, before the circuit breaker can operate. A tripped circuit breaker may be due to the presence of a ground fault condition, or may be due to the breaker itself being faulty. Check for leakage current to ground. If none is found, try raising the adjustable thresholds on the breaker, and if it still trips, it is likely defective.

TEST Button on VSD Logic Board – When the VSD is not running, this button may be used to test operation of the logic outputs to the poles, as well as the operation of the gate driver boards on the pole assemblies. When this button is depressed, six output LEDs on the VSD logic board alternately light the three plus (+) LEDs, then the three minus (-) LEDs. At the same time, two LEDs on each output pole assembly will alternate between dim and bright intensity. Several conditions can inhibit this test function:

- If any VSD fault exists.
- If the unit is in pre-charge.
- If the SCR trigger is enabled.
- If the VSD unit is running.
- If the 4 minute timer has not timed out.

Pole Assembly Replacement Procedure

The following step by step procedure includes several

helpful hints which should make the process easier, and minimize the possibility of damage to other components or to the VSD.

Before unpacking the new pole, check for presence of any residual voltage on the new pole using a Simpson meter. Allow any charge to drain off before handling the pole. Save the carton and all pieces of foam padding. This packing is to be re-used when returning a defective pole as required for warranty.

Be certain the VSD has been de-energized for over five minutes, and then double check for presence of voltage using a VOM. The DC bus must be fully discharged. Personnel not familiar with AC drives and proper electrical safety procedures should not be working on this product.

The coolant must be drained to below the level of the pole to be replaced. Save the coolant in a clean jug or one previously used for coolant. Coolant may be re-used, provided it is clean and not cloudy in appearance. Once the coolant has been drained, remove both hoses from the pole, and use electrical tape or duct tape to seal the two hose barbs on the rear of the pole to be replaced. **This is very important!** When you later lift the defective pole out of the cabinet, there will always be some coolant remaining inside the heatsink. This coolant is **conductive**, and as little as one drop falling on the gate driver board of an adjacent pole can cause the adjacent pole to fail! Now remove the four hex-head bolts which secure the pole heatsink to the cabinet's back-wall.

The laminated bus structure is removed next. Remove the large bolts at the bottom of the bus which attach the DC power cables to the copper plates. Also disconnect wire #226A from the copper plate on the right side. The two large vertically oriented resistors on the copper bus must be disconnected from the Bus Isolator board, and from the pigtail wires coming from each pole assembly. Once all this wiring is disconnected, you can remove the nine bolts holding the outer copper plate, and set this plate aside. The insulator sheet will also be free to be removed. Set this sheet in a location where it will be protected from dirt, and cannot be creased or torn. The nine bolts holding the inner copper plate may now be removed, along with the inner plate.

On the 503 HP VSD, it is necessary to remove the upper bolts holding the red, fiberglass vertical support holding the left corner of each shelf used to hold each pole assembly. The two bottom bolts are fairly non-accessible, but they may be left as-is. This support may be tilted away from the upper shelf at the top of the VSD. This provides enough clearance to remove the poles.

Disconnect the motor wires and the smaller output snubber wire, where they tie to the copper bus bar coming

from the pole to be removed. Also disconnect the pole's CT plug and thermistor plug located in this same area. There are two connections to the gate driver board on top of the pole which must also be disconnected. These are the two-pin 120 VAC plug, and the shielded cable which goes to the VSD logic board.

The defective pole is now ready to be removed. Although the 351HP and 503HP poles weigh less than 70 pounds, the 790HP poles weigh considerably more. On VSD units which are not at floor level, lifting the pole out of the VSD, and getting it down to the floor, may require some planning.

Installation is the reverse of the above procedure. With the replacement pole inside the VSD, and with its hose barbs sticking out the back of the cabinet, install the four bolts into the heatsink, but do not tighten them. This allows the pole to be moved slightly to permit aligning the bolts for the laminated bus.

On 503HP units, reinstall the red fiberglass support. Reconnect the motor leads and snubber wire. Plug in the CT connector, the thermistor connector, and the two plugs which plug into the gate driver board. Mount the inner copper plate, carefully aligning its nine bolts. The insulator sheet may be positioned with its holes resting on the bolt-heads of the first nine bolts. Then position the outer copper plate and align the second set of nine bolts. Once all eighteen bolts are aligned, tighten all these bolts securely.

Reconnect all of the wires to the two large resistors, and be certain the pigtail wires are connected to each pole assembly. Reconnecting the large DC bus cables and wire #226A completes the wiring. You can now tighten the four bolts on the back of the cabinet, and reconnect the two hoses. Follow the standard procedure for refilling the coolant and purging air from the system.

All poles failing in warranty must be returned for warranty credit. Contact YORK factory service for an RMA number and shipping instructions. Be sure the coolant is drained from the pole before boxing, and also try to place the foam blocks around the pole in the same manner as with the pole you received. Defective poles which are damaged during return shipment will not be accepted for credit, and cost of the pole may be charged back to your service operation.

In-Warranty Parts Return – Any VSD parts failing within the standard warranty period must be returned. Contact YORK factory service for instructions.

EPROM REFERENCE LIST

Original and Style "A" Units

| Location | Part Number |
|------------------|---------------|
| YT Microboard | 031-01676-001 |
| YK Microboard | 031-01675-001 |
| ACC Board | 031-01674-001 |
| VSD Logic u34 | 031-01617-001 |
| VSD Logic u45 | 031-01618-001 |
| VSD Logic u40 | 031-01619-001 |
| Filter Logic u42 | 031-01633-001 |
| Filter Logic u26 | 031-01680-001 |

Style "B & C" Units - 60 HZ Only

| Location | Part Number |
|------------------|---------------|
| YT Microboard | 031-01676-003 |
| YK Microboard | 031-01675-003 |
| ACC Board | 031-01674-002 |
| VSD Logic u34 | 031-01617-003 |
| VSD Logic u45 | 031-01618-001 |
| VSD Logic u40 | 031-01619-001 |
| Filter Logic u42 | 031-01633-003 |
| Filter Logic u26 | 031-01680-002 |

Style "B & C" Units - 50 HZ Only

| Location | Part Number |
|------------------|---------------|
| YT Microboard | 031-01676-002 |
| YK Microboard | 031-01675-002 |
| ACC Board | 031-01674-002 |
| VSD Logic u34 | 031-01617-002 |
| VSD Logic u45 | 031-01618-002 |
| VSD Logic u40 | 031-01619-001 |
| Filter Logic u42 | 031-01633-002 |
| Filter Logic u26 | 031-01680-002 |

Style "D" Units - 60 HZ Only

| Location | Part Number |
|------------------|---------------|
| YT Microboard | 031-01675-003 |
| YK Microboard | 031-01676-003 |
| ACC Board | 031-01674-002 |
| VSD Logic u34 | 031-01617-005 |
| VSD Logic u45 | 031-01618-001 |
| VSD Logic u40 | 031-01619-001 |
| Filter Logic u42 | 031-01633-005 |
| Filter Logic u26 | 031-01680-003 |

Style "D" Units - 50 HZ Only

| Location | Part Number |
|------------------|---------------|
| YT Microboard | 031-01675-002 |
| YK Microboard | 031-01676-002 |
| ACC Board | 031-01674-002 |
| VSD Logic u34 | 031-01617-004 |
| VSD Logic u45 | 031-01618-002 |
| VSD Logic u40 | 031-01619-001 |
| Filter Logic u42 | 031-01633-004 |
| Filter Logic u26 | 031-01680-003 |

