



**MILLENNIUM®
CENTRIFUGAL LIQUID CHILLERS**

SERVICE INSTRUCTIONS

Supersedes: See Back Cover

Form 160.55-M1 (101)

OPTIVIEW™ CONTROL CENTER

- 371-02264-104 (ELECTRO-MECHANICAL STARTER - NEMA 1)
- 371-02486-104 (ELECTRO-MECHANICAL STARTER - CE)
- 371-02448-104 (ELECTRO-MECHANICAL STARTER - NEMA 4/12)
- 371-02264-105 (SOLID STATE STARTER - NEMA 1)
- 371-02486-105 (SOLID STATE STARTER - CE)
- 371-02448-105 (SOLID STATE STARTER - NEMA 4/12)
- 371-02264-106 (VARIABLE SPEED DRIVE - NEMA 1)
- 371-02486-106 (VARIABLE SPEED DRIVE - CE)
- 371-02448-106 (VARIABLE SPEED DRIVE - NEMA 4/12)

MODEL YT (STYLE J)

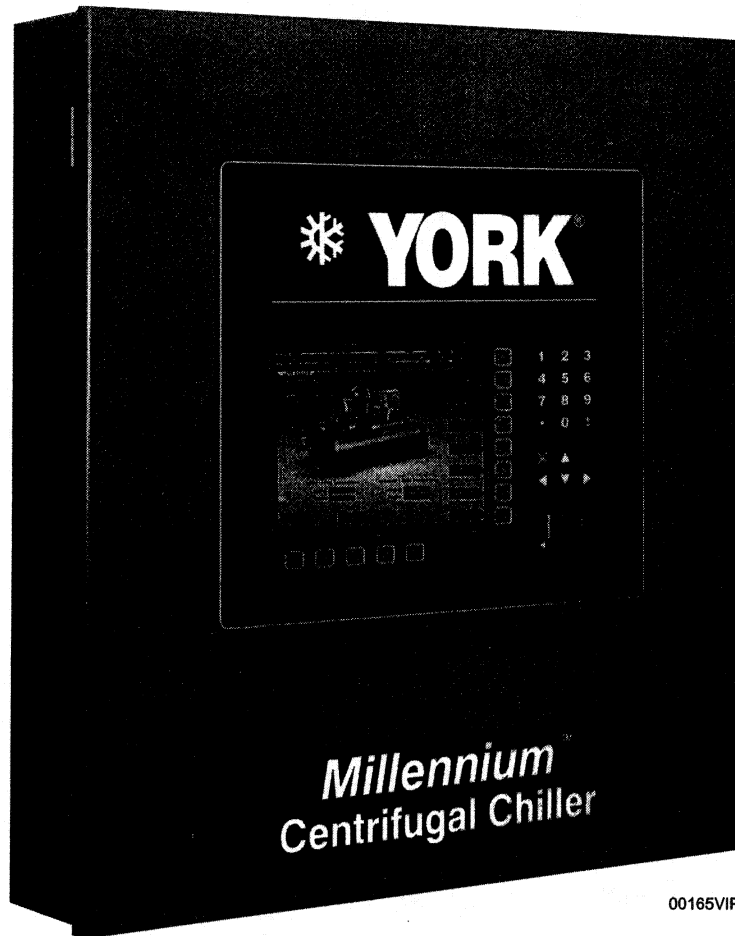

00165VIP



IMPORTANT!

READ BEFORE PROCEEDING!

GENERAL SAFETY GUIDELINES

This equipment is a relatively complicated apparatus. During installation, operation, maintenance or service, individuals may be exposed to certain components or conditions including, but not limited to: refrigerants, oils, materials under pressure, rotating components, and both high and low voltage. Each of these items has the potential, if misused or handled improperly, to cause bodily injury or death. It is the obligation and responsibility of operating/service personnel to identify and recognize these inherent hazards, protect themselves, and proceed safely in completing their tasks. Failure to comply with any of these requirements could result in serious damage to the equipment and the property in which

it is situated, as well as severe personal injury or death to themselves and people at the site.

This document is intended for use by owner-authorized operating/service personnel. It is expected that this individual possesses independent training that will enable them to perform their assigned tasks properly and safely. It is essential that, prior to performing any task on this equipment, this individual shall have read and understood this document and any referenced materials. This individual shall also be familiar with and comply with all applicable governmental standards and regulations pertaining to the task in question.

SAFETY SYMBOLS

The following symbols are used in this document to alert the reader to areas of potential hazard:



DANGER indicates an imminently hazardous situation which, if not avoided, will result in death or serious injury.



CAUTION identifies a hazard which could lead to damage to the machine, damage to other equipment and/or environmental pollution. Usually an instruction will be given, together with a brief explanation.



WARNING indicates a potentially hazardous situation which, if not avoided, could result in death or serious injury.

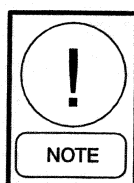

NOTE is used to highlight additional information which may be helpful to you.



External wiring, unless specified as an optional connection in the manufacturer's product line, is NOT to be connected inside the micro panel cabinet. Devices such as relays, switches, transducers and controls may NOT be installed inside the micro panel. NO external wiring is allowed to be run through the micro panel. All wiring must be in accordance with YORK's published specifications and must be performed ONLY by qualified YORK personnel. YORK will not be responsible for damages/problems resulting from improper connections to the controls or application of improper control signals. Failure to follow this will void the manufacturer's warranty and cause serious damage to property or injury to persons.

CHANGEABILITY OF THIS DOCUMENT

In complying with YORK's policy for continuous product improvement, the information contained in this document is subject to change without notice. While YORK makes no commitment to update or provide current information automatically to the manual owner, that information, if applicable, can be obtained by contacting the nearest YORK Applied Systems Service office.

It is the responsibility of operating/service personnel as to the applicability of these documents to the equipment in question. If there is any question in the mind of operating/service personnel as to the applicability of these documents, then, prior to working on the equipment, they should verify with the owner whether the equipment has been modified and if current literature is available.

REFERENCE INSTRUCTIONS

DESCRIPTION	FORM NO.
SOLID STATE STARTER (MOD "A") – OPERATION & MAINTENANCE	160.46-OM3.1
SOLID STATE STARTER (MOD "B") – OPERATION & MAINTENANCE	160.00-O2
VARIABLE SPEED DRIVE – OPERATION	160.00-O1
VARIABLE SPEED DRIVE – SERVICE INSTRUCTIONS	160.00-M1
INSTALLATION	160.55-N1
OPERATION	160.55-O1
WIRING DIAGRAM – UNIT WITH ELECTRO-MECHANICAL STARTER	160.55-PW1
WIRING DIAGRAM – UNIT WITH MOD "B" SOLID STATE STARTER	160.55-PW2
WIRING DIAGRAM – UNIT WITH VARIABLE SPEED DRIVE	160.55-PW3
RENEWAL PARTS – UNIT	160.48-RP5
RENEWAL PARTS – OPTIVIEW CONTROL CENTER	160.55-RP1

NOMENCLATURE

The model number denotes the following characteristics of the unit:

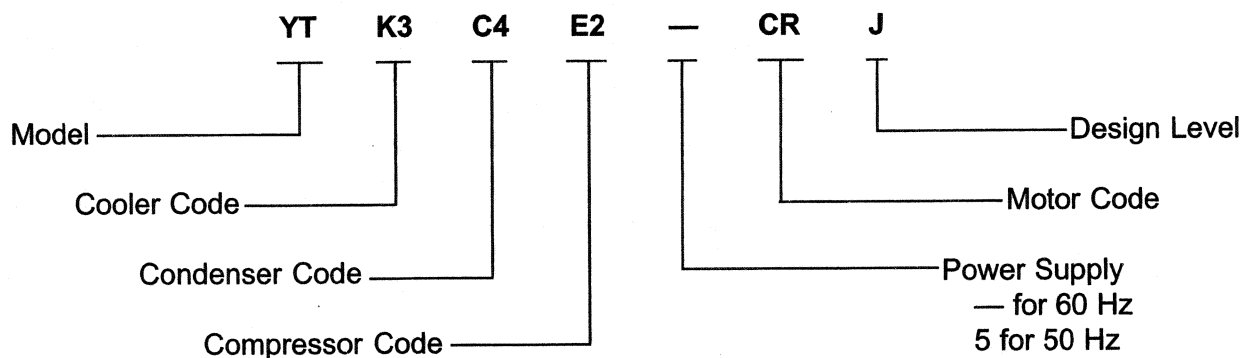

TABLE OF CONTENTS

SECTION	1	Introduction	8
SECTION	2	System Architecture	9
		Figure 1 - Block Diagram, Electro-Mechanical Starter Applications	11
		Figure 2 - Block Diagram, Mod "A" Solid State Starter Applications	12
		Figure 3 - Block Diagram, Mod "B" Solid State Starter Applications	13
		Figure 4 - Block Diagram, Compressor Motor Variable Speed Drive Applications	14
		Figure 5 - Operation Sequence Timing Diagram (Electro-Mechanical Starter & Solid State Starter Applications)	15
		Figure 6 - Operation Sequence Timing diagram (Compressor Motor Variable Speed Drive Applications)	15
SECTION	3	Microboard	16
		Figure 7 - Microboard	22
		Figure 8 - Flash Memory Card	23
		Figure 9 - Block Diagram, Microboard	24
		Table 1 - Program Jumpers	25
		Table 2 - Program Switches	27
		Figure 10- Microboard Lamp Dimmer Circuit	28
		Figure 11 - Microboard Serial Data Communications Ports	29
		Figure 12 - Configurable Analog and Remote Setpoint Inputs	30
SECTION	4	I/O Board	31
		Figure 13 - I/O Board	33
		Figure 14 - Digital Inputs	34
		Figure 15 - Typical Opto-coupler Circuit	35
		Figure 16 - Typical Field Connections	35
		Figure 17 - Digital Outputs	36
SECTION	5	Liquid Crystal Display	39
		Figure 18 - Display, Mounting	42
		Figure 19 - SHARP LQ10D367 Display Assembly	43
		Figure 20 - SHARP LQ10D421 Display Assembly	43
		Figure 21 - NEC NL6448AC33-24 Display Assembly	44
		Figure 22 - LG SEMICON LP104V2-W Display Assembly	44
		Figure 23 - Typical Control Signal Timing	45
		Figure 24 - Backlight Lamp Replacement (SHARP LQ10D367)	46
		Figure 25 - Backlight Lamp Replacement (SHARP LQ10D421)	46
		Figure 26 - Backlight Lamp Replacement (NEC NL6448AC33-24)	47
		Figure 27 - Backlight Lamp Replacement (LG SEMICON LP104V2-W) .	47

SECTION	6	Display Interface Board	48
		Figure 28 - Display Interface Board	49
SECTION	7	Display Backlight Inverter Board	50
		Figure 29 - Backlight Inverter Board, SHARP LQ10D367 & LG Semicon LP104V2-W Display	51
		Figure 30 - Backlight Inverter Board, SHARP LQ10D421 Display	52
		Figure 31 - Backlight Inverter Board, NEC NL6448AC33-24 Display	52
SECTION	8	Keypad	53
		Figure 32 - Keypad	54
		Figure 33 - Diagram, Keypad	55
SECTION	9	Power Supply	56
		Figure 34 - Power Supply	57
		Figure 35 - Block Diagram, DC Power Distribution	58
<hr/>			
SECTION	10	Current Module (CM-2)	58
		Figure 36 - Current Module	60
		Figure 37 - Block Diagram, Current Module	60
		Figure 38 - Interface, Current Transformers & Variable Resistors	61
SECTION	11	Solid State Starters	62
		Figure 39 - Mod "B" Solid State Starter – Interface	63
		Figure 40 - Solid State Starter – Logic Board	65
		Figure 41 - Mod "A" Liquid Cooled Solid State Starters Interface	68
		Figure 42 - Mod "A" Solid State Starter Logic Board	69
SECTION	12	Adaptive Capacity Control (ACC) Board	70
		Figure 43 - ACC Board	76
		Figure 44 - Interface, ACC Board	77
		Figure 45 - Block Diagram, ACC Board	78
SECTION	13	Purge System	79
		Figure 46 - Purge System	81
		Figure 47 - High Efficiency Purge System – Interface	82
		Figure 48 – Lower Emissions Purge System	85
		Figure 49 – Lower Emissions Purge System - Purge Canister Alarm Interface	86

SECTION	14	Refrigerant Level Control	83
		Figure 50 - Refrigerant Liquid Level Sensor	85
		Figure 51 - Refrigerant Liquid Level Sensor - Interface	86
SECTION	15	MicroGateway	87
		Figure 52 - Block Diagram	88
SECTION	16	Pressure Transducers	90
		Figure 53 - Pressure Transducers	91
SECTION	17	Temperature Thermistors	92
		Figure 54 - Leaving Chilled Liquid Temperature, Volts/Temp Chart	93
		Figure 55 - Return Chilled Liquid Temperature, Volts/Temp Chart	98
		Figure 56 - Return and Leaving Condensing Water, Volts/Temp Chart	100
		Figure 57 - Oil and Discharge Temperature, Volts/Temp Chart	104
		Figure 58 - Drop Leg refrigerant Temperature Volts/Temp Chart	109
		Figure 59 - Evaporator Temperature Volts/Temp Chart	109
SECTION	18	Remote Setpoints	110
SECTION	19	Hot Gas Bypass	115
		Figure 60 - Interface, Hot Gas Bypass	118
SECTION	20	Smart Freeze Protection	119
SECTION	21	Surge Protection	119
SECTION	22	System Calibration, Service Setpoints and Reset Procedures	121
		Electro-Mechanical Starter Applications	
		Variable Resistors (RES)	121
		CM-2 Current Module	121
		Solid State Starter Applications	
		Mod "B" Solid State Starter	122

- Mod "A" Solid State Starter 123
 - Logic Board 123
 - Compressor Variable Speed Drive Applications 124
 - Logic Board 124
 - Pre-rotation Vanes Potentiometer 125
- Purge System 127
- Refrigerant Level Control (Future)..... 128
- High Condenser Pressure Warning Threshold 129
- Brine Low Evaporator Pressure Cutout Threshold 129
- Leaving Chilled Liquid Temperature Control Sensitivity 130
- Drop Leg Refrigerant Temperature 130
- Smart Freeze Protection 130
- Evaporator Refrigerant Temperature Sensor 130
- Sales Order Data 131
- Custom User ID and Passwords 132

- SECTION 23 Diagnostics and Troubleshooting 133**
 - Main Diagnostics Screen 134
 - Figure 61 - Main Diagnostics Screen 134
 - Keypad Test 135
 - Figure 62 - Keypad Test Screen 135
 - Display Test 136
 - Figure 63 - Display Test Main Screen 136
 - Figure 64 - Bit Pattern Test Screen 137
 - Serial I/O Test 138
 - Figure 65 - Serial I/O Test Screen 138
 - Figure 66 - Com 5 Serial Data Port and Loop-back Connector 139
 - Digital I/O Test 140
 - Figure 67 - Digital I/O Test Screen 140
 - Analog Inputs Test..... 142
 - Figure 68 - Analog Inputs Test Screen 142
- SECTION 24 System Commissioning Checklist 146**

SECTION 1

INTRODUCTION

This document explains the operation of the printed circuit boards and major components of the Control Center to a level that allows a Service Technician to troubleshoot and locate the source of a problem.

The overall system architecture is described and illustrated with block diagrams. This describes the general function of each component and provides the system interface and signal flow. The function of each component and signal flow between components must be understood before effective troubleshooting can commence.

The operation of each printed circuit board is described and illustrated with a block diagram that is a simplified representation of board circuitry. The expected voltage level at all inputs and outputs of each board for any operating condition is provided.

Included in this document are procedures that have to be performed at chiller commissioning or during service. They should not be performed by anyone other than a Service Technician. For example, calibration procedures have to be performed or verified at system commissioning or when a component is replaced. Certain Safety shutdowns require special reset procedures to be performed before the chiller can be restarted. Since the operating program supplied in each Control Center is universal to all applications, special setpoints, program jumpers and program switches are required to configure the chiller for local operating conditions.

A System Commissioning Checklist is provided as reference of items to be performed during chiller commissioning.

In addition to this document, several levels of supporting documentation are required while servicing the system. Field Control Modifications Diagram 160.55-PW7 provides details of the interface to remote devices. Operations Manual 160.55-O1 explains the operation of the Control Center Keypad, how to enter Setpoints and explains all the messages displayed on the Control Center display. The following wiring diagrams provide the

connections between the printed circuit boards and components within the Control Center:

- YORK Form 160.55-PW1 – Chillers equipped with Electro-mechanical starter
- YORK Form 160.55-PW2 – Chillers equipped with YORK Solid State Starter (Mod B)
- YORK Form 160.55-PW3 – Chillers equipped with YORK Variable Speed Drive

When the chiller shuts down on a **SAFETY** or **CYCLING** shutdown or is being prevented from starting, a message is displayed providing the reason for the shutdown. This message, along with all the chiller operating conditions at the instant of the event are stored in the Microboard battery-backed memory. This history data can be displayed or printed using an optional printer. The Operations Manual 160.55-O1 provides a detailed description of this message, including the conditions required to produce the message and conditions required to restart the chiller.

Diagnostic Routines allow service analysis of the following functions:

- Display
- Analog inputs
- Digital inputs
- Digital outputs
- Serial Data ports

Before beginning any troubleshooting, observe the shutdown message and retrieve the **HISTORY** data of that event. Refer to the Operations Manual for an explanation of the message. The conditions required to produce the message must be clearly understood before proceeding. (If this is not heeded, much time will be wasted). Armed with a knowledge of the overall system architecture and the function of each printed circuit board and signal flow provided by this manual, proceed with the appropriate Wiring Diagram listed above to trace the problem through the system. Use the Diagnostic Routines where appropriate.

SECTION 2

SYSTEM ARCHITECTURE

2

The Control Center performs the following functions:

- Controls chiller capacity to chill liquid to the chilled liquid temperature setpoint.
 - Controls chiller solenoid valves, relays, actuators and motor contactors per the operating program.
 - Displays chiller operating conditions, alarms, shut-down messages and history data.
 - Accepts operator-programmed setpoints and controls the chiller accordingly.
 - Allows manual control of chiller motor contactors and actuators.
-
- Monitors chiller operating conditions and shuts down chiller when Safety or Cycling thresholds are exceeded.
 - Allows local manual start/stop and accepts start/stop commands from remote devices, via contact closures or serial communications.
 - Allows setpoints to be changed from a remote location via 0-10VDC, 2-10VDC, 0-20mA, 4-20mA, contact closures or serial communications.
 - Provides chiller operating data and status to remote devices via serial communications and contact closures.
 - Allows real-time data and history data to be printed on an optional printer.
 - Controls the compressor motor starter and contains a printed circuit board logic that supports Electro-mechanical Starters, Solid State Starters and YORK Variable Speed Drive.

The Control Center is a microprocessor based control system that receives analog, digital and serial data inputs and controls analog, digital and serial data outputs per instructions in the operating program. A panel mounted display and touch-sensitive keypad permit local operation.

System pressures are sensed by pressure **transducers**. The output of each transducer is a DC voltage that is analogous to the pressure input. System temperatures are sensed by **thermistors**. The output of each thermistor is a DC voltage that is analogous to the temperature it is sensing. Typical output voltage range of both is 0.5 to 4.5VDC. These are **analog** inputs to the Control Center.

Digital Inputs are on/off inputs to the Control Center in the form of switch and relay contacts. These inputs are 115VAC when the contacts are closed and 0VAC when open. These include flow switches, local start/stop switch, remote cycling and high pressure safety device, etc.

Digital Outputs are on/off outputs from the Control Center in the form of relay contacts and triacs. The relay contacts typically switch 115VAC and the triacs typically switch a nominal 30VAC. Relay outputs include status/alarm, chiller solenoid valves, oil heater, oil pump starter and chilled and condenser water pump starters, etc. Triac outputs include pre-rotation vane control and variable orifice control (future).

Serial Data is transmitted to and received from devices in RS-232, RS-485 and TX/RX (opto-couple) form.

The Control Center supports three types of starters; Electro-Mechanical Starter, Solid State Starter Mod "A" or "B" and Variable Speed Drive. However, all Control Centers contain the following standard components, regardless of the starter type applied:

- Microboard
- I/O (input/output) Board
- Keypad
- Display
- Power Supply

In addition to the standard components, the Control Center contains a printed circuit board that provides certain control and interface functions for the starter type applied. Each starter type requires a different board as follows:

- Electro-mechanical Starter - CM-2 Current Module
- Solid State Starter (Mod "A" only) - Logic Board
- Variable Speed Drive - Adaptive Capacity Control Board

Figures 1 through 4 are Control Center block diagrams of the three starter types. On each block diagram, the standard components are shown, along with the printed circuit board that supports the applied starter type. Figures 5 and 6 are Operation Sequence timing diagrams of the different starter applications.

The microprocessor and all supporting logic circuits, along with the memory devices containing the operating program, reside on the **Microboard**. All chiller operating decisions are made here. It receives analog and digital inputs from the chiller and remote devices. The analog inputs are connected directly to the Microboard. The digital inputs are received via the **I/O Board** (see description below). Under Program control, the Microboard operates the relays and triacs that are located on the **I/O Board**.

The **I/O Board** acts as an input/output device for the Microboard. It conditions the digital input signals for the Microboard and contains relays and triacs that are controlled by the Microboard to control solenoids, motor contactors and actuators. The 115VAC digital inputs from switch and relay contacts are converted to logic level voltages by Opto-Couplers. The relays have +12VDC coils that are energized and de-energized by the Microboard. The contacts of these relays control the 115VAC system solenoids, relays and motor contactors. The triacs are turned on and off by the Microboard. The outputs of these triacs control actuators.

A front panel-mounted **Keypad** allows Operator and Service Technician user interface. Membrane keys are used to display chiller and system parameters, enter setpoints and perform chiller and Control Center diagnostics. It also contains a **START-RUN-STOP/RESET** Switch that is used to locally start and stop the chiller and perform manual reset functions.

A front panel mounted liquid crystal **Display** allows graphic animated display of the chiller, chiller subsystems and system parameters. The chiller and working components of the chiller are displayed, along with chiller operating pressures and temperatures. The Keypad is used to select displays showing increasing levels of detail of chiller working components.

A self-contained **Power Supply** supplies the necessary DC voltages for all the components within the Control Center.

When the compressor motor is driven by an Electro-mechanical Starter, the Control center is equipped with a **CM-2 Current Module**. This printed circuit board provides current overload and power fault protection for the compressor motor. Current Transformers, located in the compressor motor terminal box, along with rectifying and calibration circuitry, provide an analog voltage representing compressor motor current to the CM-2 Module. This signal is further conditioned and provided to the Microboard.

When the compressor motor is driven by a YORK Solid State Starter, there could be either of two different Solid Starters applied. New production chillers are equipped with the Mod "B" Solid State Starter. This starter contains a combination Logic/Trigger Board that interfaces the Microboard via a serial communications link. Earlier vintage chillers, such as those encountered in Control Center retrofit applications, are equipped with the Mod "A" Solid State Starter. This starter contains a Trigger Board that interfaces to a Logic Board that is installed inside the Control Center. The Logic Board interfaces the Microboard via a multiplexed data interface.

When the compressor motor is driven by the YORK Variable Speed Drive (VSD), the Control Center is equipped with an **Adaptive Capacity Control Board**. This printed circuit board monitors system parameters and controls the VSD to drive the compressor at the slowest speed it will operate without surging, while maintaining required chiller capacity.

Serial data interface to the YORK ISN Building Automation System is through the optional **MicroGateway**, mounted inside the Control Center. This printed circuit board requests the required data from the Microboard and makes it available for the ISN network.

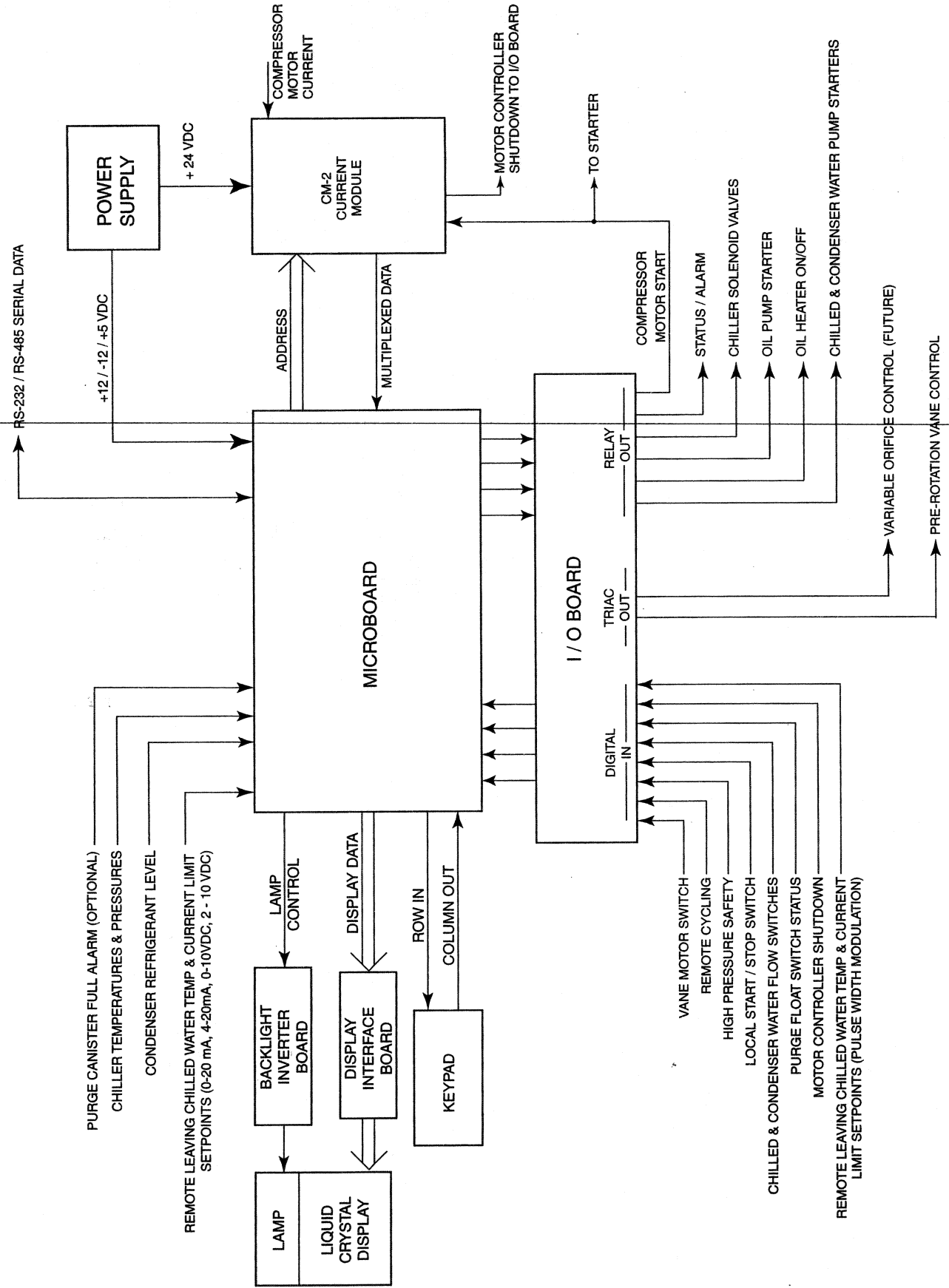
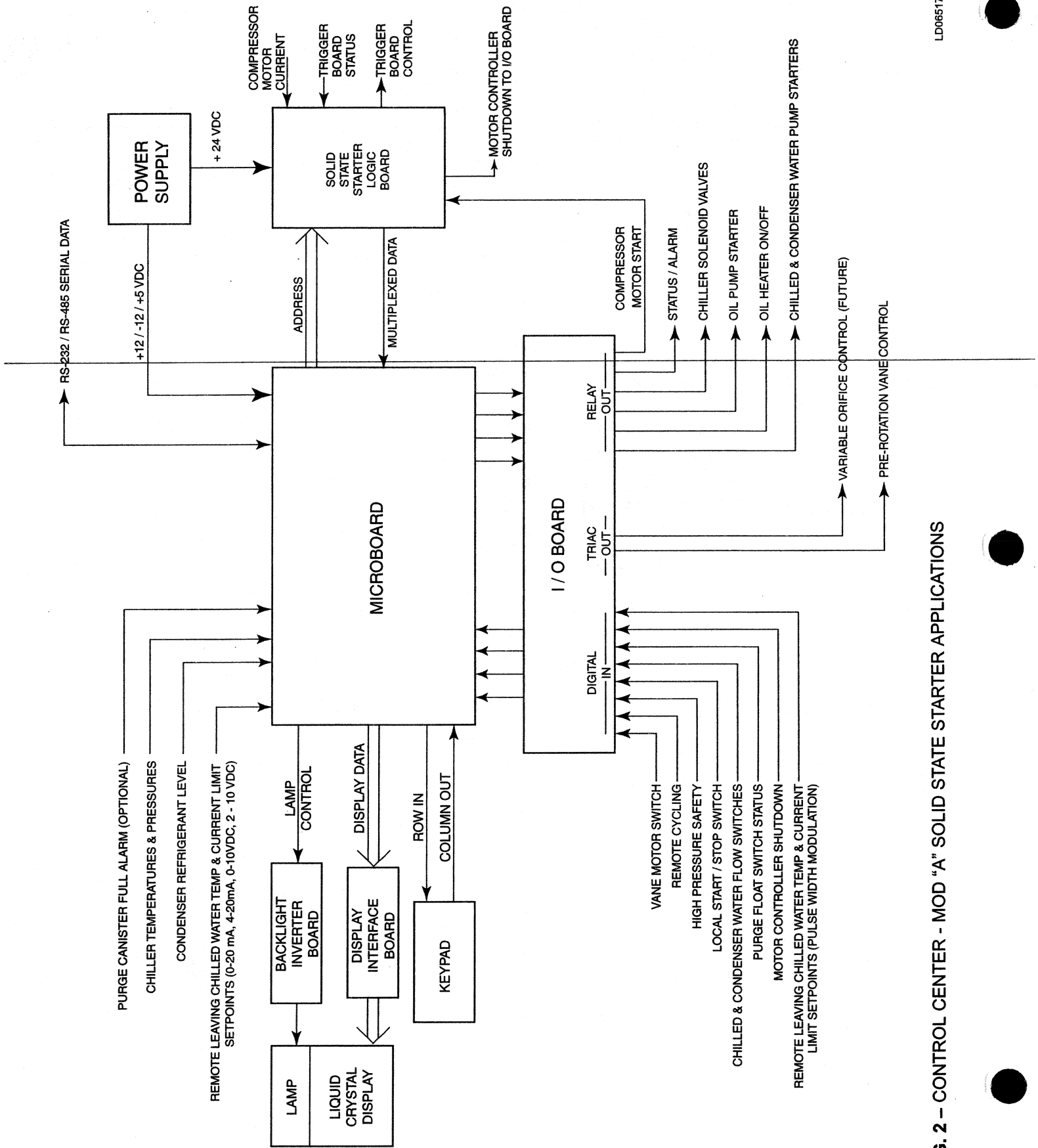

FIG. 1 - CONTROL CENTER - ELECTRO-MECHANICAL STARTER APPLICATIONS



LD06517

FIG. 2 - CONTROL CENTER - MOD "A" SOLID STATE STARTER APPLICATIONS

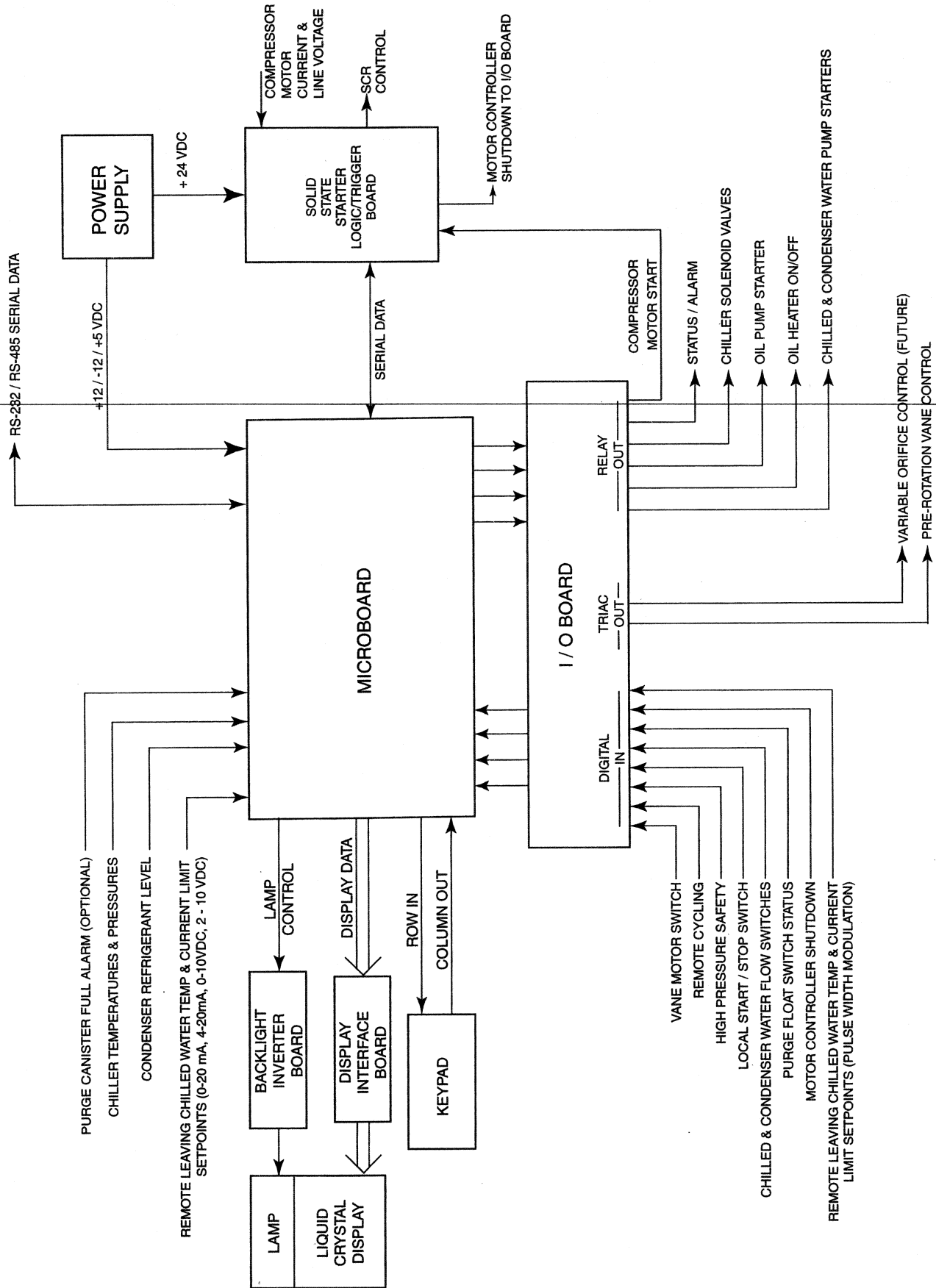

FIG. 3 - CONTROL CENTER - MOD "B" SOLID STATE STARTER APPLICATIONS

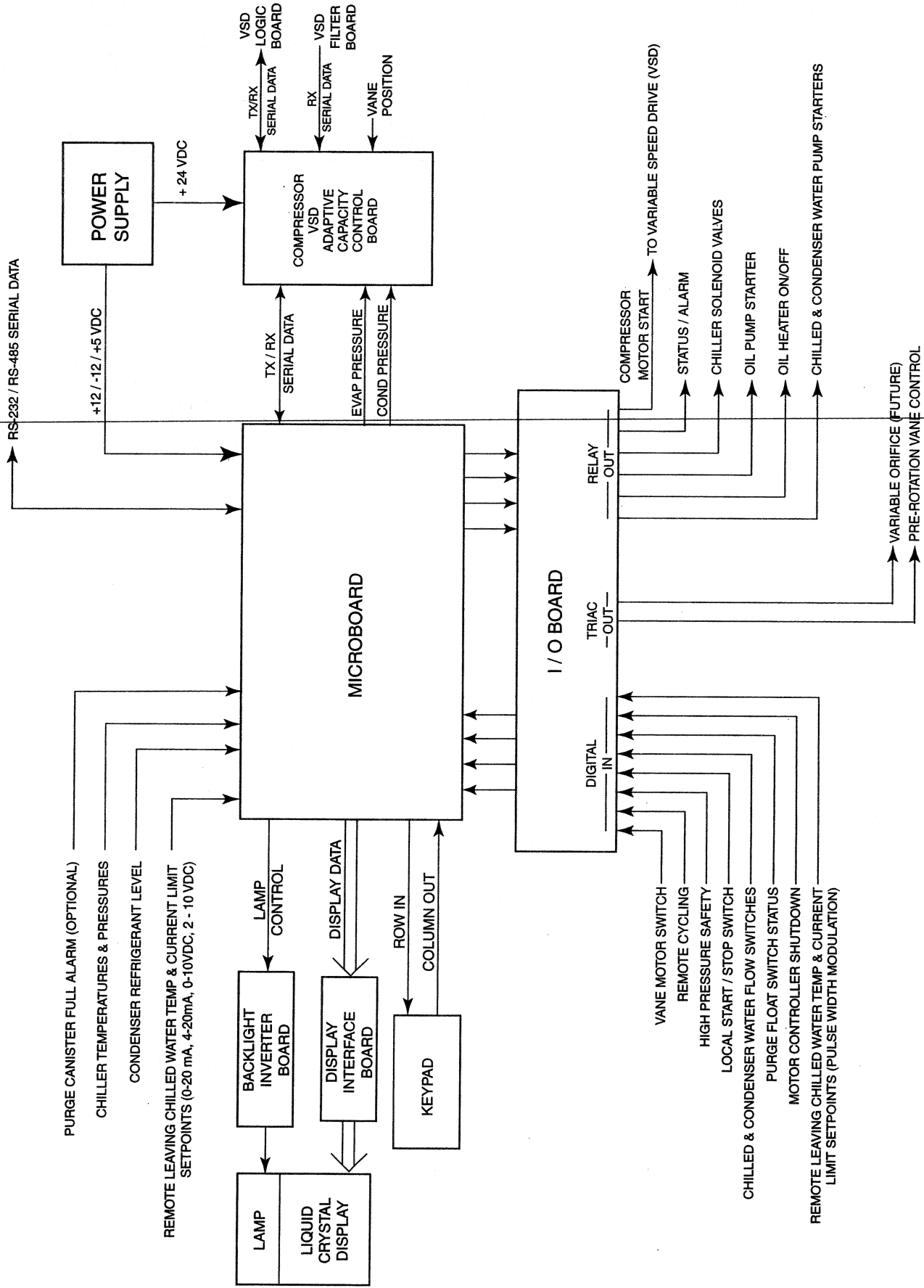

FIG. 4 - CONTROL CENTER - COMPRESSOR MOTOR VARIABLE SPEED DRIVE

LD06520

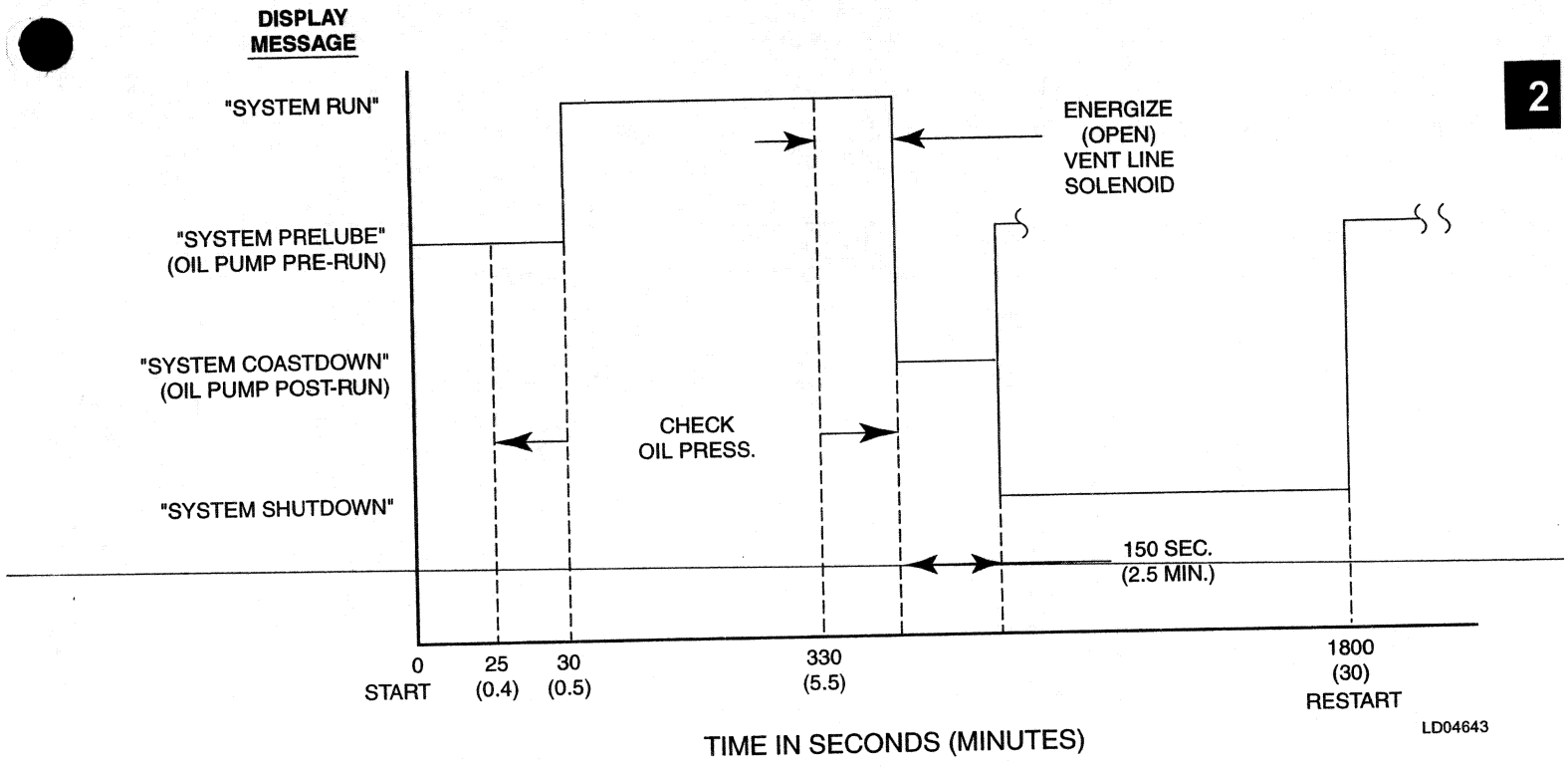

FIG. 5 – OPERATION SEQUENCE TIMING DIAGRAM (ELECTRO-MECHANICAL AND SOLID STATE STARTER APPLICATIONS)

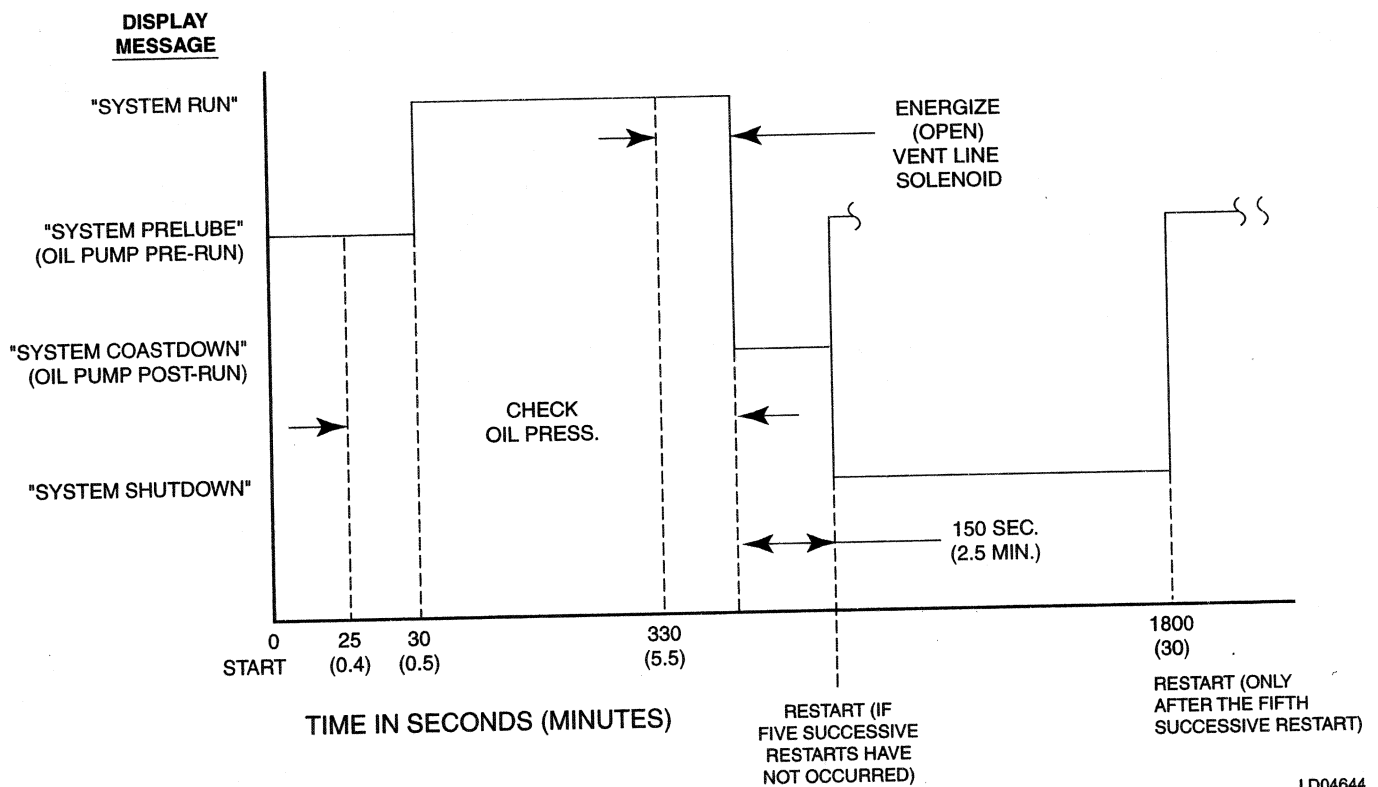

FIG. 6 – OPERATION SEQUENCE TIMING DIAGRAM (COMPRESSOR MOTOR VARIABLE SPEED DRIVE APPLICATIONS)

SECTION 3

MICROBOARD

(REFER TO FIG. 7 - 12)

The **Microboard** contains the operating software (Program), microprocessor (Micro), and supporting circuits for the Micro.

The **Program** is a set of instructions to control the chiller, the display and peripheral devices. It also contains the Safety and Cycling shutdown thresholds (non changeable) and Display messages and screens. It is stored in a memory device called a **flash memory card**. This is a type of nonvolatile memory that can be read from or written to, but requires the locations to be erased before they are written to. With the exception of a write/read sequence that occurs during the Boot-up process explained below, this device is used primarily as read-only in this application. A write protect switch is located on the left edge of the card as shown in Fig. 8. It must be placed in the "Write Enabled" position in order to allow successful Boot-up. The card is located in socket location U46 (ref. Fig. 8). It connects to the Board via an Elastomeric connector that is a silicon rubber strip embedded with silver conductors. The Card can be removed from its socket by using the thumb to press down on the socket's plastic tension spring. The card is installed by inserting it into the socket/holder and pressing on the surface of the Card until it snaps into place. The Memory card is a replaceable component. Refer to YORK Renewal Parts List Form 160.55-RP1. The version of the Memory card is an alphanumeric code that represents the application and revision level. The version is printed on a label adhered to the memory card's surface. The version code is as follows:

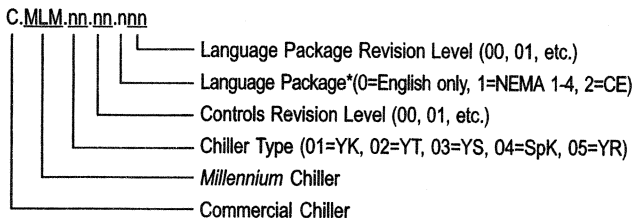

There are several Flash Memory Cards available. The difference between them is the different languages that can be displayed on the Display Screens. Language selection is performed on the USER Screen following instructions in Operations Manual 160.55-O1. Not all languages are available. Refer to Renewal Parts List 160.55-RP1 for list of available Flash Memory Cards

and display languages. **IMPORTANT!** – Not all versions of Flash Memory Cards are compatible with revision "E" (and later) Microboards or all BIOS Eproms. If an incompatible version is used, the initialization (boot-up) process will not complete and the chiller will not run! Refer to Renewal Parts List 160.55-RP1 and "Service Replacement" paragraph in this section.

The **Micro** controls the chiller by reading and executing the Program instructions in a sequence determined by the Program. Under Program control, the Micro reads the Analog and Digital Inputs to determine the operating conditions and controls Digital Outputs based upon these inputs. These inputs are compared to stored thresholds to determine if a Safety or Cycling shutdown is required. If a threshold has been exceeded, a shutdown is performed and the appropriate message is retrieved from the Program and displayed on the Liquid Crystal Display. As operating conditions require, status messages are retrieved and displayed. The Keypad is read as Digital Inputs. When an operator presses a key to request a display, the Micro interprets the request, retrieves the display from the Program and displays it. The Program assembles data in the correct format for transmission through the Serial Data Ports to peripheral devices. The Program also instructs the Micro to respond to requests from peripheral devices for serial data transmissions.

The **MUX** (multiplexer) is a switching device that only allows one analog input through at a time. The inputs are selected sequentially by the Micro per Program instructions.

The **A/D Converter** converts each analog input to a 12-bit word. In this form, the values can be stored in memory devices, compared to values in the Program, transmitted through Serial Ports or sent to the Display Controller for display. Control signals to start conversion process are from the Micro via the FPGA.

The **Watchdog** circuit monitors the +5VDC supply from the external Power Supply to determine when a power failure is occurring. Just prior to the supply decreasing to a level where the Micro and supporting circuits can no longer operate, it applies a reset signal to the Micro. The Micro responds by de-energizing the run digital output through the FPGA, shutting down

the chiller and retrieving the **Power Failure** message from the Program and sending it to the Display Controller for display. Similarly, when power is first applied after a power failure, it maintains the Micro in a reset state until the +5VDC has returned to a sufficient level. The Watchdog circuit also assures that all the Program instructions are being performed and that the Program has not latched-up, bypassing important safety thresholds. If the Program has latched-up, The Micro initiates a Safety shutdown and displays **WATCHDOG – SOFTWARE REBOOT** message.

The **Program Jumpers** (Table 1) and **Program Switches** (Table 2) are used to alter the Program operation or configure the Microboard hardware for specific operation. This allows the Program and Microboard to be universal for all applications of the chiller. Refer to Table 1 and 2 for the function of each jumper and switch. The position of some can be determined and set by the Service Technician to meet the desired operation or chiller application. The position of others is dictated by the size, type or style of certain Control Center components and thus the position is determined by the YORK Factory. The required position of each is listed in these tables. The Program Jumpers are wire bridges that are either left in place or cut. The Program Switches are miniature switches that are placed in either the **ON** or **OFF** position.

The **DRAM** (dynamic random access memory) is a non battery-backed memory device. The Micro stores data here temporarily for further processing. Data in this device is lost during power failures. DRAM differs from RAM in that DRAM must be periodically refreshed in circuit.

The **BIOS EPROM** (basic input/output system erasable programmable read only memory) is a memory device that contains the bootstrap or power-up program. It is located in socket location U45. This EPROM is replaceable. Refer to YORK Renewal Parts List Form 160.55-RP1. The EPROM version is an alphanumeric code that represents the application and revision level. The version is printed on a label adhered to the EPROM's surface. The version code is as follows:

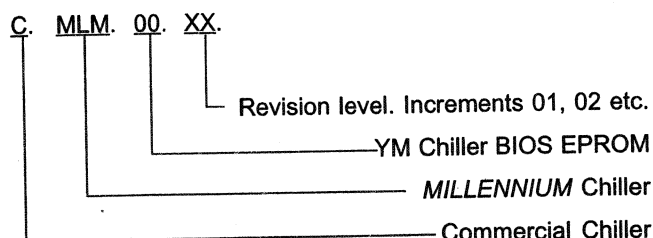

There are two different BIOS Eproms. Eprom 031-01796-001 can only be used in revision "A" through "D" Microboards. Eprom 031-01796-002, although it can be used in revision "A" through "D" Microboards, is required in revision "E" and later Microboards to support the use of either 65548 or 65550 Display Controllers (U29). **IMPORTANT!** Eprom 031-01796-002 is **NOT** compatible with all versions of Flash Memory Cards. If an incompatible Flash Memory Card version is used with this BIOS, the initialization (boot-up) process will not complete and the chiller will not run! (refer to Renewal Parts List 160.55-RP1 and "Service Replacement" paragraph in this section.

When power is applied to the Control Center following a power failure, the Micro executes the instructions in the BIOS EPROM program to initialize, configure and start operation of certain Microboard components before the main program (stored in the Flash Memory Card) is started. Depending upon the application, the Microboard could be equipped with an EPROM that has either 128K, 256K, or 512K capacity. Microboard Program Jumper JP38 must be positioned according to the actual EPROM installed. Refer to Table 1 (Program Jumpers). There are 5 steps to the boot-up process. During the boot-up process, there is a visual indication as each step is performed, followed by a Pass/Fail status of the step. On the Microboard, a green LED (CR17 - Pass) flashes to indicate the step was successful. If a step is unsuccessful, a red LED (CR18 - Fail) flashes and the Boot-up process terminates. The execution and Pass/Fail status of steps 3 through 5 are displayed on a white Keypad Display Screen as they are performed. This white display screen also lists the BIOS EPROM Version. The steps of the Boot-up process are as follows. Also, below is listed the LED activity associated with each step.

BOOT-UP STEP AND DESCRIPTION

1. First initiate table complete.

Registers in the Micro are configured to allow it to perform basic memory read/write functions.

2. FPGA configuration.

The Field Programmable Gate Array (FPGA) is configured to process Digital Inputs and Outputs.

3. Mini-card signature test.

A location in the Flash Memory Card that contains a code identifying the Manufacturer is compared to other locations that contain the manufacturer's name. If these values are the same, it is **pass**. If they are different, it is **fail**.

4. Mini-card checksum.

The **Flash Memory Card** checksum is calculated and compared to the checksum value that is stored in the Card at the time the Card was initially programmed at the YORK factory. If both values are the same, it is considered **pass**. If the calculated value is different than the stored value, it is considered **fail**.

5. BRAM quick test.

Test data is written to and then read from several memory locations to verify BRAM operation.

LED INDICATORS

When power is applied to the Control Center, both the red (CR18 - Fail) and green LED's (CR17 - Pass) simultaneously illuminate for 1 second, then the Boot-up process begins in the following sequence. When all steps have been completed, both LED's illuminate and remain illuminated.

STEP	PASS	FAIL
1	Green on, Red off	Watchdog will initiate a re-boot.
2	Green flash once	Boot-up process halts. One red flash repeating
3	Green flash once	Boot-up process halts. Two red flashes repeating
4	Green flash once	Boot-up process halts. Three red flashes repeating
5	Green flash once	Boot-up process halts. Four red flashes repeating

The **BRAM** (battery backed random access memory) is a memory device that contains a battery that preserves the data during power failures. It is a replaceable part. Refer to YORK Renewal Parts List Form 160.55-RP1. It is located in socket location U52. The Micro stores the setpoints programmed by the Operator or Service Technician, History Data and other data that requires preservation, in this device. Also, the day of week, time of day and calendar date time-keeping are done here.

The **FPGA** (field programmable gate array) is a single chip consisting of generic circuits that can be configured to perform a specific task. In this Control Center, it is used to control the Digital Outputs. As part of the power-up initialization sequence, each time control power is applied to the Control Center, the Micro configures the FPGA to control the Digital Outputs. During chiller operation, the Micro controls the Digi-

tal Outputs by writing the desired output state, logic low (<+1VDC) or logic high (+VDC) to the FPGA. Writing a logic high actually turns off the output, allowing it to be pulled up by the source voltage applied to the device connected to this output. These voltages could be +5VDC, +12VDC or +24VDC. Therefore, when the Micro turns off the output, the actual voltage measured at the output will vary according to the voltage connected to this output. The FPGA latches and holds this state until changed by the Micro. The Micro controls the relays and triacs on the I/O Board (via Microboard J19) by writing the desired state to the FPGA. To energize a relay or turn on a triac, the FPGA output is a logic low voltage level (<+1VDC). To de-energize a relay or turn off a triac, the output is a logic high voltage level (+12VDC). The outputs that control the compressor motor start relay (K13 on I/O Board) and the chilled water pump start/stop relay (K0 on I/O Board) have anti-recycle timers associated with them. The output that controls K13 will not change at a rate greater than once every 20 seconds. The output that controls K0 will not change at a rate greater than once every 10 seconds. The FPGA is used to read the keypad (via Microboard J5) to determine if any keys are being pressed. The **keypad** is a matrix of conductors arranged in rows and columns (ref. Fig. 32 & 33). There are 4 rows and 8 columns. When a key is pressed, the conductors are pressed together at that point, creating continuity between that row conductor and the column conductor. The Keypad is read by applying a logic low to a row while leaving +5VDC pullup on all the other rows. The Micro then reads the 8 columns. If any column has a logic low on it, the key corresponding to that coordinate (row, column) is being pressed. The Micro reads the entire Keypad by repeating this routine beginning with row 1 and ending with row 4. The entire Keypad is read every Program cycle. The Micro selects the MUX inputs (Microboard J7, J8, J9) for input to the A/D Converter by writing sequential addresses to the FPGA. The FPGA holds each address until a new one is received from the Micro. As each address is applied to the MUX, the input corresponding to that address is passed through the MUX to the A/D Converter. The A/D Converter will convert the analog value to a digital word when the Micro writes a "start conversion" pulse to the FPGA. The FPGA passes this to the A/D Converter. The Micro retrieves certain operating parameters (via Microboard J10) from the compressor motor starter control board (CM-2 Current Module or Solid State Starter Logic Board, Mod A) by writing addresses to it via the FPGA. The addresses, 0 through 7 are written sequentially. On

the Mod A starter control board is an 8 channel MUX. As each address is received by the starter control board MUX, it causes the appropriate analog value to be passed to the Microboard as an analog input and processed as described above. The Micro determines the type of starter applied by the voltage received from channel 0. A voltage of $<0.4\text{VDC}$ indicates the starter is electro-mechanical type; $\geq 0.4\text{VDC}$ indicates starter type is Mod A solid state. If it determines there is an electro-mechanical starter present, it reads channel 7 and processes the 0-4VDC output and displays it as %FLA. If it determines there is a Mod A Solid State Starter present, the channel 0 voltage indicates the starter size (model) and voltmeter range (300V or 600V). Channel 1 is a hardware generated current limit command that will force current limit control at 100%FLA (prevent vanes from opening) and 104%FLA (drive vanes closed until current $<102\%$), regardless of the software current limit operation. Channels 2 through 4 are analog voltages that represent phase A, B and C motor current. Channels 5 through 7 are analog voltages that represent Phase A, B and C line voltage.

The addresses and associated data are shown below.

CM-2 Board		Solid State Starter Mod A Logic Board	
Address	Data	Address	Data
0 thru 6	Gnd	0	starter model / voltmeter range
		1	current limit command
7	Peak Motor Current	2 - 4	phase C, B, A motor current
		5 - 7	phase A, B, C line voltage

The **Input Buffers** latch and hold the Digital Inputs (Microboard J19) from the I/O Board and the column outputs from the keypad until read by the Micro. 115VAC digital inputs from relay contacts and external devices are converted to +5VDC logic levels by the I/O Board prior to application to the Microboard. Similarly, the Keypad column outputs are held and read by the Micro as described above.

To provide flexibility for future Analog Inputs (to Microboard J7), 2 analog inputs can be configured for either 0-10VDC, 2-10VDC, 0-20mA or 4-20mA, Transducer or Thermistor inputs using Program Jumpers JP21 through JP24. The position of the jumper determines which type of input can be connected. Refer to Fig. 12 and Table 1, "Program Jumpers".

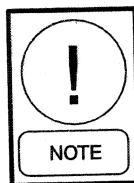

These inputs are for future YORK Factory expansion use only. They are not general application spare inputs that will support arbitrarily installed devices. Devices CANNOT be connected to these inputs until the program has been modified to read and process the input. Unless YORK documentation shows a device connected to the input with a defined function, the input cannot be used.

Remote Leaving Chilled Liquid Temperature and Current Limit Setpoints can be applied to the RS-232 serial port J2 via the GPIC or directly to the Microboard at J22 (ref. Fig. 11). The inputs at J22 can be configured with Program Jumpers JP23 and JP24 to accept these inputs in either 0-10VDC, 2-10VDC, 0-20mA or 4-20mA form. Refer to Table 1 for Program Jumper configurations.

The Microboard receives 3 supply voltages (Microboard J1) from the **Power Supply**; +12VDC, -12VDC, +5VDC and Ground. The -12VDC and +12VDC are used directly by various circuits. The +12VDC and +5VDC are input to **Voltage Regulators** to derive other regulated voltages. The +5VDC (fused by 5 Amp fuse F1 on rev "E" boards) is input to a +3.3VDC regulator. The output is a 3.3VDC regulated voltage. The +12VDC (fused by 5 Amp fuse F2 on rev "E" boards) is input to a 5VDC regulator. The output of this regulator powers only the Analog circuits. This includes the MUX, A/D converter, CM-2 module, Solid State Starter (Mod A) Logic Board, Transducers and Thermistors. As depicted on Fig. 5, these voltages can be monitored at Test Posts TP1 through TP6.

The **Microboard** is equipped with 5 **Serial Data Ports** (ref. Fig. 11). Connector J2 is shared with both COM 1 and COM 4B. Each Port is dedicated for a specific function as follows:

- COM 1 (J2) - RS-232. Printer.
- COM 2 (J13) - RS-232. Not Used.
- COM 3 (J12) - RS-485. Optional I/O.
- COM 4 (4A-J11), (4B-J2) - This port is actually two ports. However, they cannot be used simultaneously; only one of these ports can be connected to a device at a time. The position of Microboard Program Jumper J27 determines which port can be used (refer to Table 1). COM 4A (J11) is an

RS-485 port that is used for Multi-Unit Communications. COM 4B (J2) is an RS-232 port that is used for MicroGateway.

- e.) COM 5 (J15) – Opto-coupled TX/RX. VSD Adaptive Capacity Control board or Mod B solid state starter.

COM 1 is connected directly to the Micro. COM 2 through 5 are connected directly to the **UART** (Universal Asynchronous Receive Transmit). The UART converts the parallel data to serial form for transmission to the peripheral device and converts the incoming serial data to parallel form for use by the Micro. It also generates and processes control signals for the Modem communications (DTR, CTS, DSR, RTS). Under Program control, the Micro instructs the UART of the desired data transmission Baud rate. A crystal oscillator provides the frequency reference. Each port is equipped with two LED'S; a red one indicates when data is being transmitted to the remote device and a green one indicates when data is being received from the remote device. The RS-232 output voltages are industry standard ± 3 to ± 15 VDC, with ± 9 VDC typical. The RS-485 output voltages are industry standard ± 1.5 to ± 5 VDC, with ± 2.5 VDC typical. The TX/RX signals of COM 5 are 0 and +5VDC logic level signals. A loopback diagnostic test can be performed on each serial port. This test permits verification of the data transmitted from the serial port. Refer to "Diagnostics" section of this book for details if these tests.

The graphic screens that are displayed on the **Liquid Crystal Display** are created from preformed graphics and messages that are stored in the Program (FLASH Memory Card), and real-time system operating parameters, such as system pressures and temperatures. The graphics, message and number data are in the form of digital words. The **Display Controller** converts this data into display drive signals and sends them to the Display from Microboard J5. The Display has 307,200 pixels arranged in a 640 columns x 480 rows matrix configuration. Each pixel consists of 3 windows; red, green and blue, through which a variable amount of light from the Display **backlight** is permitted to pass through the front of the display. Imbedded in each window of the pixel is a transistor, the conduction of which determines the amount of light that will pass. The drive signal determines the amount of conduction of the transistor and therefore the amount of light passed through the window. The overall pixel color becomes a result of the gradient of red, green and blue light allowed to pass. The drive signal for each pixel is an 18 bit binary word; 6 for each of the 3 colors, red, green and blue.

The greater the binary value, the greater the amount of light permitted to pass. The pixels are driven sequentially from left to right, beginning with the top row. To coordinate the drive signals and assure the pixels in each row are driven sequentially from left to right and the columns are driven from top to bottom, each drive signal contains a horizontal and vertical sync signal.

The **Display DRAM** is a memory device that supports the operation of the **display controller**. This device could be either of two types; FPM (fast page mode) or EDO (extended data out) type. Program Jumper JP6 must be positioned according to the type of DRAM device installed in the Microboard; JP6 in - EDO, out - FPM. Refer to Table 1, "Program Jumpers". Depending upon the requirement, there could be one or two DRAM devices installed in the Microboard. If the design requires only one DRAM, it is installed in socket U27. If an additional one is required, it is installed in socket U25.

During the power-up sequence, the program in the BIOS EPROM reads Program Jumper JP6 to determine the type of **Display DRAM** installed (as explained above). It also reads wire jumpers PID0 through PID3 (via Microboard J5) on the **Display Interface Board** to determine the manufacturer of the display (refer to description of Display Interface Board). Each display manufacturer requires a slightly different control. The program in the BIOS EPROM then configures the **Display Controller** for operation with the actual display that is present.

Revision "A" through "D" Microboards are equipped with Display Controller (U29) type 65548. Revision "E" and later boards could be equipped with either a 65548 or 65550 Display Controller. To accommodate the use of either device, BIOS Eprom part number 031-01796-002 is required on revision "E" and later Microboards. Also, Program Jumpers JP43 and JP44 (refer to Table 1) must be configured according to the actual Display Controller installed on the board. These jumpers are positioned appropriately at the time the board is manufactured and should not require field configuration.

Different display manufacturers can require different supply and control voltages for their displays and backlights. Program Jumpers JP 2 through 4 and 5 through 8 must be configured to provide the required supply and control voltages to the display and backlight control. Table 1 lists the required Program Jumper configuration for each Display. Also, a label attached to the Display mounting plate lists the required Program Jumper configuration for that particular Display.

The power supply voltage that operates the **Display** is provided by the Microboard J5. The position of Program Jumper JP2 determines whether this supply voltage is +5VDC or +3.3VDC. The **Display** requires a specific power-up and power-off sequencing to prevent damage. During power-up, the supply voltage must be applied to the **Display** before the drive signals are applied. Similarly, during power-off sequencing, the display drive signals must be removed prior to removing the supply voltage. The **Display Controller** applies the supply voltage and data drive signals to the **Display** in the proper sequence. The **Display Controller** controls the **Display Backlight** by applying control signals (from Microboard J6) to the **Backlight Inverter Board**. The **Backlight Inverter Board** converts low voltage DC (+12VDC or +5VDC, depending on position of Program Jumper JP5) to high voltage AC (500 to 1500VAC). This high voltage AC is applied to the lamp to cause it to illuminate. The **Backlight** is turned on and off with the "Enable Backlight" (J6-5) signal. The position of Program Jumper JP4 determines whether this is a +12VDC or +5VDC signal. In some displays, the **Backlight** turns on when this signal transitions from low to high; others turn on when it transitions from high to low. The position of Program Jumper JP3 determines the transition that will occur when the Display Controller outputs the "Enable Backlight" signal. Program Jumper JP3 must be positioned according to the Display manufacturer's requirement.

Under Program control, the **Display Controller** controls the Backlight brightness via the **Lamp Dimmer** circuit. In order to extend the life of the backlight lamp, the lamp brightness is driven to 50% brightness after 10 minutes of Keypad inactivity. At this brightness level, the Display can still be read. Subsequently, when Keypad activity is detected (i.e.; a Keypad key is pressed), the lamp is driven back to full brightness (100% brightness). Some display manufacturers require a variable voltage to vary the brightness; others require a variable resistance. Program Jumpers JP7 and JP8 allow either method to be used. The **Lamp Dimmer** is an integrated circuit that is the electrical equivalent of a 10K ohm potentiometer with 100 positions or steps (ref. Fig. 10). The **Display Controller** controls the position of the potentiometer. The **Lamp Dimmer** varies the brightness of the Backlight by applying either a variable voltage (0-5.0VDC) or a variable resistance (0-10K ohms), to the **Backlight Inverter Board**. If Program Jumpers JP7 and JP8 are installed, the **Lamp Dimmer** output is a variable voltage; if both are removed, the output is a variable resistance.

The Lamp Dimmer outputs "Brightness Control Wiper" (J6-7) and "Brightness Control -" (J6-8) to the **Backlight Inverter Board**. If configured for variable voltage output, the voltage between J6-7 and J6-8 can be varied from 0 (100% brightness) to 5.0VDC (0% brightness). If configured for variable resistance, the resistance between J6-7 and J6-8 would vary from 0 ohms (0% brightness) to 10K ohms (100% brightness).

The **PC-104 Port** (J16 & J17) is an industry standard arrangement of two connectors that allows the stacking of 3.6 x 3.8 inch printed circuit boards (PC-104 Modules) on the Microboard. The circuits on these boards have access to the Microboard's address/data bus, and therefore become an extension of the Microboard. This provides expansion of the Microboard's capabilities without re-designing or changing the size of the Microboard. PC-104 Modules are not used in all Control Center applications.

System pressures and temperatures, in the form of analog DC voltages from pressure transducers and temperature thermistors, are input to the **MUX** (multiplexers). Under Program control, the Micro selects these values, one at a time, for input to the Analog to Digital (A/D) converter. As each one is selected, it is passed to the **A/D Converter** for conversion to a 12-bit digital word that is then input in parallel form to the Micro. The Micro stores each value in the **DRAM** for display requests, further processing or Serial Port transmission. Each value is also stored in the **BRAM** for History data. The Micro compares each value to Safety and Cycling shutdown thresholds stored in the FLASH Memory Card. If any thresholds are exceeded, the Micro initiates a shutdown by removing the run signal to the compressor starter by de-energizing the appropriate digital output through the **FPGA**. It retrieves the appropriate shutdown message from the FLASH Memory Card and sends it to the **Display Controller** for display. If any analog inputs require the state of any digital outputs to be changed, the Micro does this through the **FPGA**.

The system Pressure Transducers are described in Section 16 of this book. Formulas and graphs are included to calculate the expected Transducer output voltage for a given input pressure.

The Temperature Thermistors are described in Section 17 of this book. Included are tables to convert the expected output voltage for any temperature applied to the Thermistor.

Service Replacement: Service Replacement Microboards are ordered under part number 331-01730-602. This part number includes an 031-01730-000 Microboard equipped as described below and the latest version of Flash Memory Card 031-02004-001.

If the Microboard is replaced within the warranty period, return the defective board along with any unused Flash Memory Cards per the Warranty Return Procedure.

Some removable components will have to be transferred from the defective board to the replacement board. The revision level of the replacement board determines which components from the defective board can be transferred to the new board. When the replacement Microboard is received, observe the revision level of the replacement board. Revision "E" and later boards have different component requirements and are supplied differently than revision "A" through "D" boards as follows:

Replacement Boards that are Revision "A" through "D":

Supplied without the following:

- BIOS Eprom (U45)
- BRAM (U52)

Remove the above devices from the defective board and use in replacement board. Transfer Flash Memory Card 031-02004-002 (available after October 2000) from the defective board to the replacement board or use latest version of Card 031-02004-001 supplied with replacement board. Select the Flash Memory Card based upon the display language requirements (refer to Renewal Parts List 160.55-RP1).

Not all combinations of Flash Memory Cards and BIOS Eproms are compatible. If incompatible versions are used, the initialization (boot-up) process will not complete and the chiller will not run! Acceptable Flash Memory Card and BIOS Eprom combinations that can be used in revision "A" through "D" Microboards are as follows:

1. BIOS Eprom 031-01796-001 can be used with Flash Memory Card 031-02004-001 (any version) or 031-02004-002 (any version; available after October, 2000).

2. BIOS Eprom 031-031-01796-002 can only be used with Flash Memory Card 031-02004-001 (version C.MLM.02.01 and later; ie., .02, .03, etc.) or 031-02004-002 (any version).

Replacement Boards that are Revision "E" or Later:

Supplied with:

- BIOS Eprom (U45) part number 031-01796-002

Supplied without:

- BRAM (U52)

Remove the BRAM from the defective board and use in the replacement board. Transfer Flash Memory card 031-02004-002 from the defective board to replacement board or use latest version of Card 031-002004-001 supplied with replacement board. Select Flash Memory Card based upon display language requirements (refer to Renewal Parts List 160.55-RP1).

Not all combinations of Flash Memory Cards and BIOS Eproms can be used in revision "E" and later boards. If incompatible versions are used, the initialization (boot-up) process will not complete and the chiller will not run! The following is the requirements:

1. BIOS Eprom 031-01796-002 is required.
2. Flash Memory Card 031-02004-001 can be used. However, it **MUST** be version C.MLM.02.01 or later (ie., .02, .03, etc.). Earlier version C.MLM.02.00 is not compatible.
3. Flash Memory Card 031-02004-002 (any version) can be used.

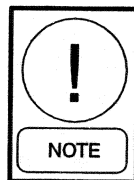

IMPORTANT! Since the BRAM memory device contains all of the programmed setpoints and Sales Order data, using the existing BRAM in the replacement Microboard eliminates the need to re-program this extremely large amount of data. The process to manually program the Sales Order Data is extremely time-consuming. However, if the BRAM fails and field replacement is necessary, follow the procedure in the "Systems Calibration, Service Setpoints and Reset Procedures" section of this book.

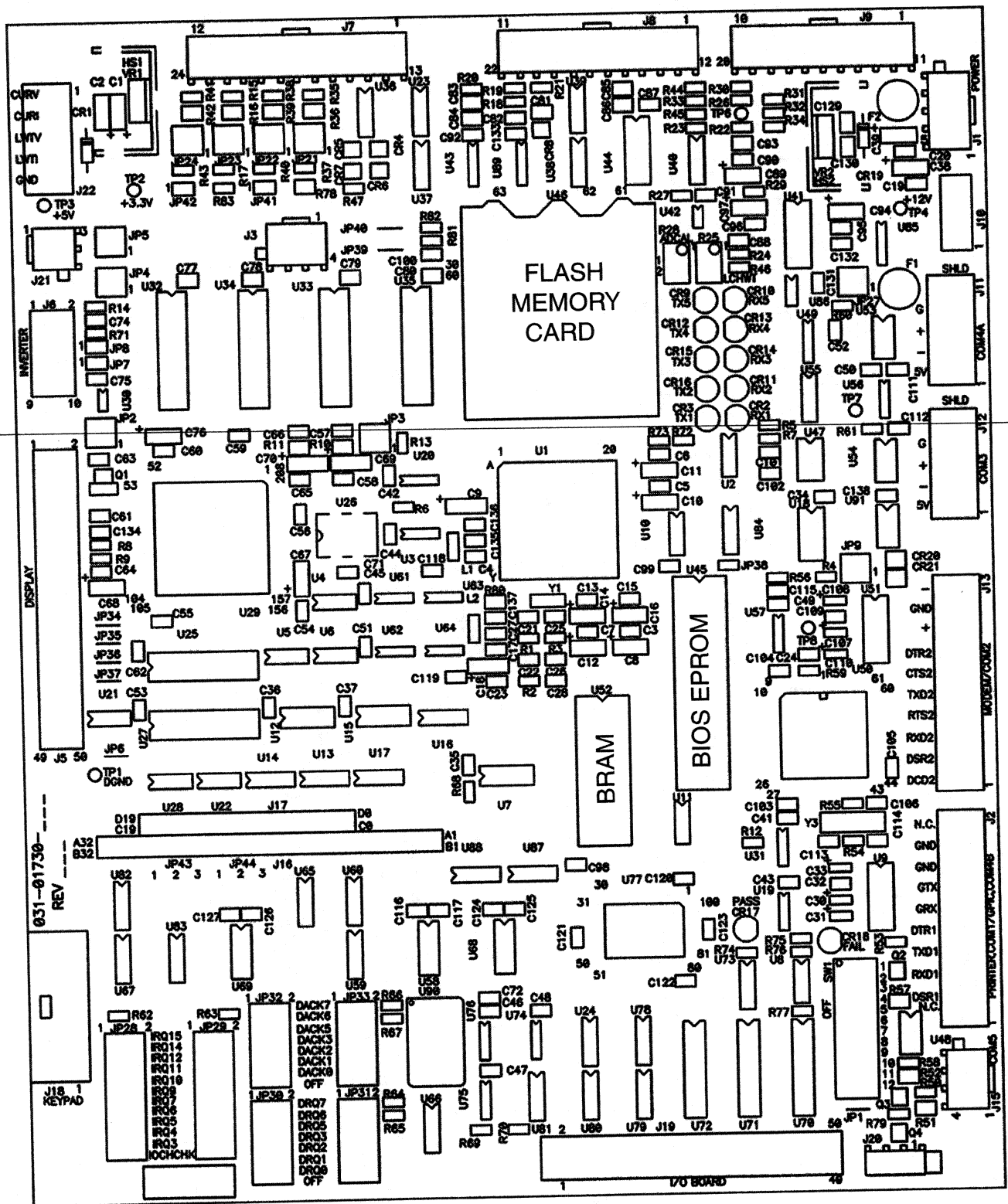

3

FIG. 7 - MICROBOARD

YORK INTERNATIONAL

LD05813

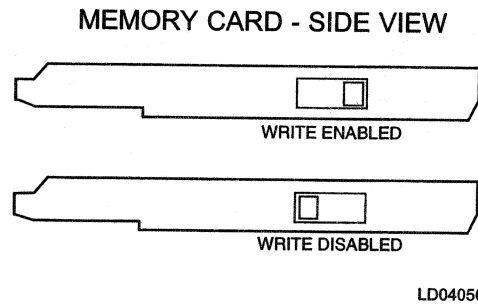
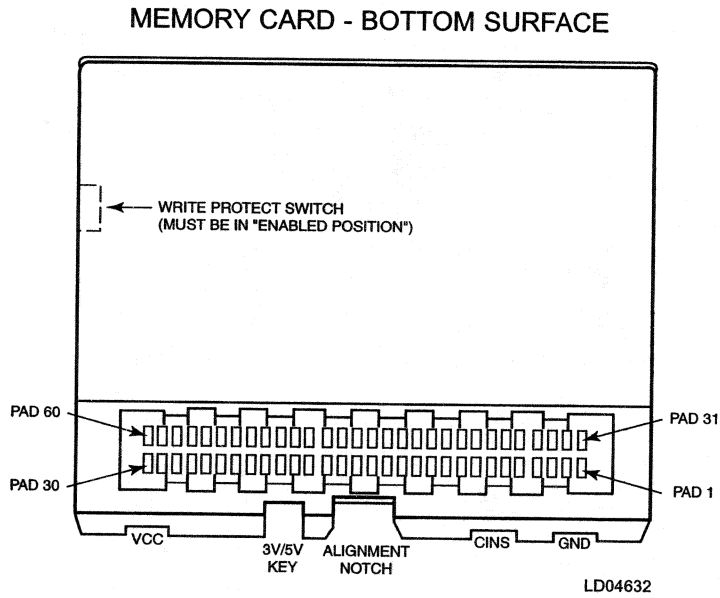
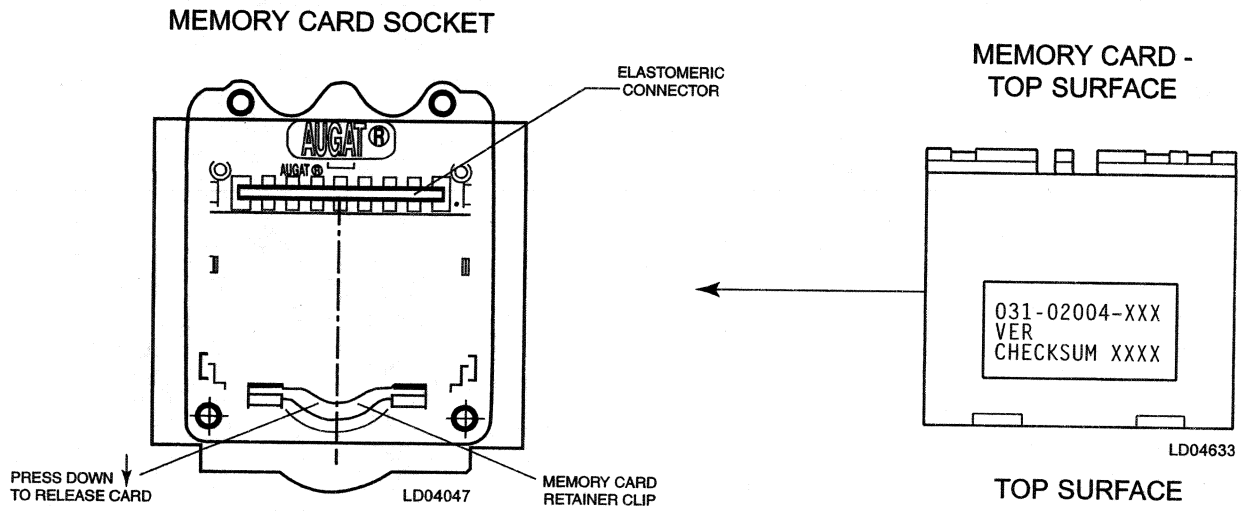
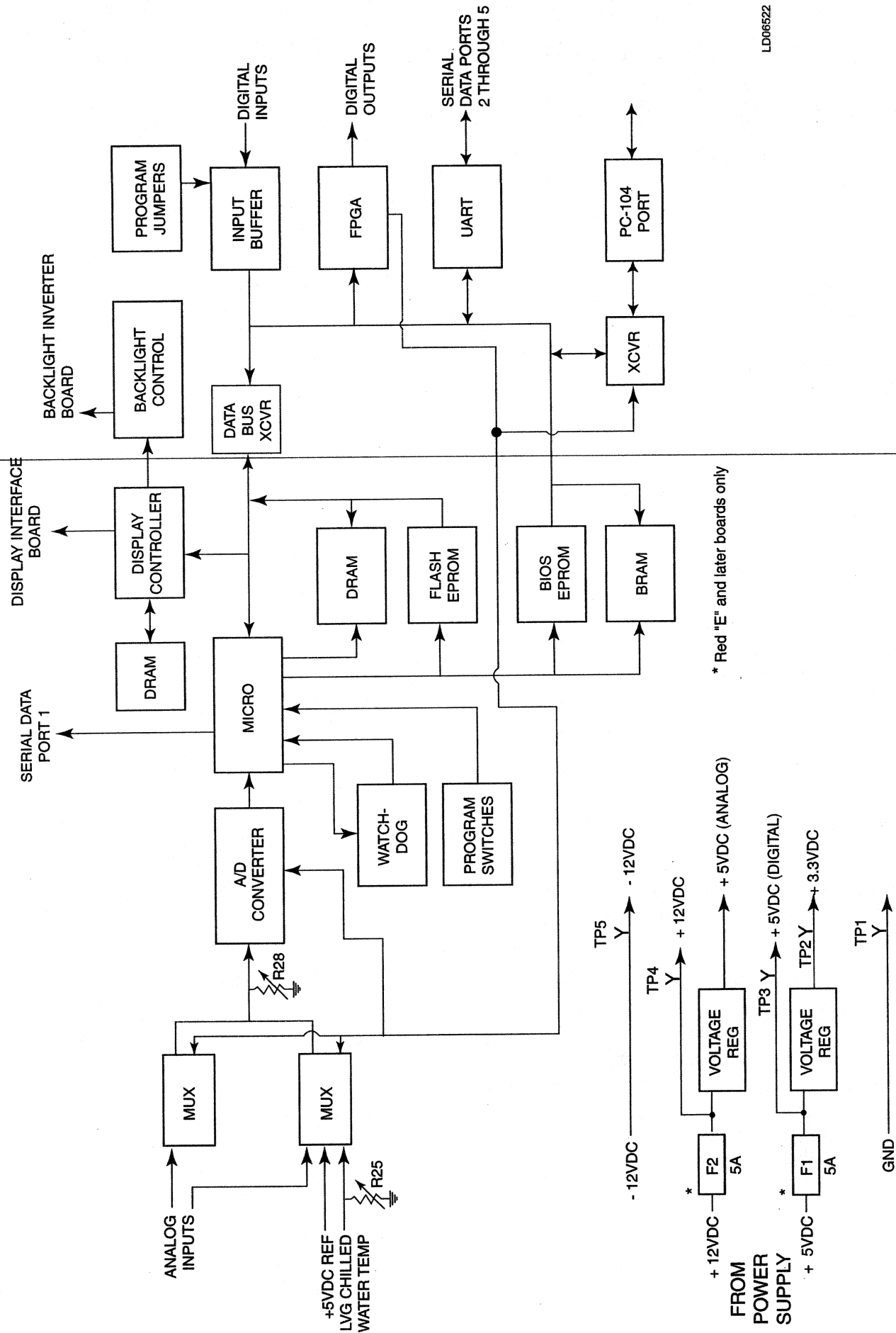

FIG. 8 - FLASH MEMORY CARD

LD06522



* Red "E" and later boards only

FIG. 9 - MICROBOARD

TABLE 1 MICROBOARD PROGRAM JUMPERS

MICROBOARD PROGRAM JUMPERS

JP1 - Watchdog enable/disable. The position of this jumper, in conjunction with Program switch SW 1 position 12 enables or disables the program Watchdog protection.



Never disable the watchdog protection. Severe compressor or chiller damage could result. The ability to disable the watchdog protection is provided for factory testing only!!!

~~**IN** - Watchdog protection enabled.~~

OUT - Permits Program switch SW1 position 12 to enable or disable the program

Watchdog protection as follows:

Position 12 **ON** - Watchdog protection enabled
OFF - Watchdog protection disabled

JP2 - Display power and logic levels. Determines the power supply voltage applied to the display.

Pins 1-2: +5VDC SHARP LQ10D367 and LQ10D421 displays.

Pins 2-3: +3.3VDC NEC NL6448ACCC33-24 and LG Semicon LP104V2-W displays.

JP3 - Display backlight enable signal level polarity. Jumper must be positioned according to the voltage level required to turn on the Display Backlight.

Pins 1-2: 0VDC SHARP LQ10D421 Display.

Pins 2-3: +12VDC or +5VDC as determined by position of JP4. SHARP LQ10D367, NEC NL6448AC33-24 and LG Semicon LP104V2-W displays.

JP4 - Display backlight enable signal logic levels. Determines the logic levels of the Backlight enable signal.

Pins 1-2: +12VDC/0VDC SHARP LQ10D421 display.

Pins 2-3: +5VDC/0VDC SHARP LQ10D367, NEC NL6448AC33-24 and LG Semicon LP104V2-W displays.

JP5 - Display backlight power. Determines the power supply voltage applied to the Display Backlight Inverter Board.

Pins 1-2: +12VDC. SHARP LQ10D367 and LQ10D421, NEC NL6448AC33-24 and LG Semicon LP104V2-W displays.

Pins 2-3: +5VDC. Not used

JP6 - Display memory type. Jumper must be positioned according to type of RAM used for display memory devices (U25 & U27).

IN - EDO: (extended data out) type. Jumper should be IN.

OUT - FPM: (fast page mode) type. Not used at this time.

JP7, JP8 - Display brightness control technique. Determines whether the display brightness is controlled by a variable voltage or variable resistance.

IN: Variable voltage (0-5.0VDC). SHARP LQ10D367 and LQ10D421, and LG Semicon LP104V2-W displays.

OUT: Variable resistance. NEC NL6448AC33-24 display.

JP9 - JP20 - Not Used

JP21 - Configurable Analog input (J7-2 & J7-14) type. Configures analog input for 0-10VDC, 4-20mA, thermistor (temperature) or transducer (pressure) input.

OUT: Allows a 0-10VDC input on J7-2 or a transducer input on J7-14.

Pins 1-2: Allows a 4-20mA input on J7-14.

Pins 2-3: Allows a thermistor input on J7-14.

JP22 - Configurable Analog input (J7-4 & J7-16) type. Configures analog input for 0-10VDC, 4-20mA, thermistor (temperature) or transducer (pressure) input.

OUT: Allows a 0-10VDC input on J7-4 or a transducer input on J7-16.

Pins 1-2: Allows a 4-20mA input on J7-16.

Pins 2-3: Allows a thermistor input on J7-16.

JP23 - Remote Current Limit Setpoint (J22) type. Configures analog input for 0-10VDC, 2-10VDC, 0-20mA or 4-20mA.

OUT: Allows a 0-10VDC or 2-10VDC input on J22-1

Pins 1-2: Allows a 0-20mA or 4-20mA input on J22-2

Pins 2-3: Not Used

JP24 - Remote Leaving Chilled Liquid Temp Setpoint (J22) type. Configures analog input for 0-10VDC, 2-10VDC, 0-20mA or 4-20mA.

OUT: Allows a 0-10VDC OR 2-10VDC input on J22-3

Pins 1-2: Allows a 0-20mA or 4-20mA input on J22-4

Pins 2-3: Not Used

JP25, JP26 - Not Used

JP27 - COM 4 serial communications port. Configures COM 4 port to be either RS-485 for Multi-Unit Communications (COM 4A) or RS-232 for GPIC board (COM4B).

Pins 1-2: Enables port 4A. Allows an RS-485 connection to Microboard J11 for Multi-Unit Communications.

Pins 2-3: Enables port 4B. Allows an RS-232 connection to Microboard J2 for MicroGateway communications.

JP28 - PC-104 Port interrupt assignment. Assigns selected PC-104 interrupt request to PIRQ7 on the microprocessor. Interrupt request selections are silk screened on the microboard adjacent to the program jumper. Not used on YT chiller applications.

JP29 - PC-104 Port interrupt assignment. Assigns selected PC-104 interrupt request to PIRQ6 on the microprocessor. Interrupt request selections are silk screened on the microboard adjacent to the program jumper. Future modem application.

JP30 - PC-104 Port DMA assignment. Assigns selected PC-104 DMA request to PIRQ0 on the microprocessor. DMA request selections are silk screened on the microboard adjacent to the program jumper. Not used on YT Chiller applications.

JP31 - PC-104 Port DMA assignment. Assigns selected PC-104 DMA request to PIRQ1 on the microprocessor. DMA request selections are silk screened on the microboard adjacent to the program jumper. Not used on YT Chiller applications.

JP32 - PC-104 Port DMA acknowledge assignment. Assigns selected PC-104 DMA acknowledge to PDACK0 on the microprocessor. DMA acknowledge selections are silk screened on the microboard adjacent to the program jumper. Not used on YT Chiller applications.

JP33 - PC-104 Port DMA acknowledge assignment. Assigns selected PC-104 DMA acknowledge to PDACK1 on the microprocessor. DMA acknowledge selections are silk screened on the microboard adjacent to the program jumper. Not used on YT Chiller applications.

JP34 - Refrigerant type. Jumper must be positioned according to the refrigerant type installed in the chiller.

IN: R11

OUT: R123

JP35 - Water/Brine application. Jumper must be positioned according to whether the chiller is cooling water or a brine solution.

IN: Water. Leaving chilled liquid temperature setpoint range 38°F (36°F if Smart Freeze is enabled) to 70°F.

OUT: Brine. Leaving chilled liquid temperature setpoint range 10°F to 70°F.

JP36 - Steam Turbine or Electric Motor drive - Determines the "Coastdown" duration (Oil Pump run duration after shutdown) and whether the "Motor Controller-Loss of Current" Program check is performed while the chiller is running.

IN: 150 seconds. Electric motor drive applications.

OUT: 15 minutes. Steam Turbine applications. "Motor controller-Loss of Current" check is not performed.

JP37 - Compressor Motor starter type.

IN: Electro-Mechanical or Solid State Starter

OUT: Variable Speed Drive

JP38 - BIOS EPROM U45 size. Jumper must be positioned according to size of U45. Jumper is a 10 Ohm resistor that is soldered to board. It is not a shunt jumper.

IN: 256K

OUT: 64K or 128K. Should be **OUT** for YT chiller applications.

JP39 - Solid State Starter style.

IN: Mod "A" Starter - Old style with Logic Board mounted in Control Center.

OUT: Mod "B" Starter - New style with integrated Logic/Trigger Board mounted Starter cabinet.

JP40 - Not Used

JP41 - Not Used

JP42 - Not Used

JP43, JP44 - Display Controller (U29) type (rev "E" and later boards only). Must be positioned according to the Display Controller type installed on Microboard. Configured at the time the board is manufactured and should not require field configuration.

Pins 1-2: Type 65548

Pins 2-3: Type 65550

TABLE 2

MICROBOARD PROGRAM SWITCHES

SW1

1 - Not Used

2 - Not Used

3 - Prerun - Determines the duration of the "Start Sequence Initiated" period, including the prelube duration.

ON: Extended prerun. "Start Sequence Initiated" period is 180 seconds in duration. Oil Pump runs for 167 seconds.

OFF: Standard prerun. "Start Sequence Initiated" period is 50 seconds in duration. Oil Pump runs for 37 seconds.

4 - Diagnostics - Enables or disables software diagnostics

ON: Enables software diagnostics. Disables normal chiller operation

OFF: Disables software diagnostics. Enables normal chiller operation.

5 - Auto-restart - Determines the course of action required to restart the chiller, if a power failure occurs while the chiller is running.

ON: Chiller will automatically restart when power is restored.

OFF: Requires a manual reset after power is restored. The chiller will not start until the operator moves the keypad **START-RUN-STOP/RESET** rocker switch to the **STOP/RESET** po-

sition. If in **LOCAL** mode, the chiller can then be restarted by initiating a local start. If in **REMOTE** mode, the chiller will restart upon receipt of a remote start signal.

6 - Anti-recycle - Enables or disables the anti-recycle timer.



The anti-recycle timer must NEVER be disabled unless it is absolutely necessary to do so during troubleshooting.

ON: Enables anti-recycle timer. Solid State Starter and Electro-Mechanical starter applications - Chiller cannot be started at intervals shorter than once every 30 minutes. VSD applications (JP37 Out) - Chiller can be started at the completion of **SYSTEM COASTDOWN** at intervals shorter than once every 10 minutes up to 5 times. On the 5th shutdown, a 10 minute timer is started and restart is inhibited until the timer has elapsed.

OFF: Disables anti-recycle timer. Chiller can be started at the completion of **SYSTEM COASTDOWN**, regardless of how long the chiller had been running.

7 - Compressor Motor Variable Speed Drive - Motor/Power Line frequency application.

ON: 50Hz

OFF: 60Hz

8 - Chilled Water Pump operation - Determines Chilled Water Pump control contacts (I/O Board TB2-44/45) operation when chiller shuts down on various **CYCLING** shutdowns.

ON: Enhanced operation. Contacts open at completion of **System Coastdown** after all shutdowns except when it shuts down on "**LEAVING CHILLED LIQUID - LOW TEMPERATURE**", "**MULTIUNIT CYCLING - CONTACTS OPEN**" AND "**SYSTEM CYCLING - CONTACTS OPEN**".

OFF: Standard operation. Contacts open at completion of **System Coastdown** after all shutdowns except when chiller shuts down on "**LEAVING CHILLED LIQUID - LOW TEMPERATURE**". On Low Water temp shutdowns, they remain closed, causing the pump to continue to run while the chiller is shutdown.

10 - Not Used

11 - Not Used

12 - Watchdog Protection -Used in conjunction with Program Jumper JP1 (see above) to enable/disable the program watchdog protection. With JP1 **IN**, this switch setting has no effect. With JP1 **OUT**, this switch setting determines whether the watchdog protection is enabled or disabled.



NEVER disable the watchdog protection! Severe compressor or chiller damage could result. The ability to disable the watchdog protection is provided for **YORK** factory testing only.

3

9 - Not Used

ON: Watchdog protection enabled.

OFF: Watchdog protection disabled.

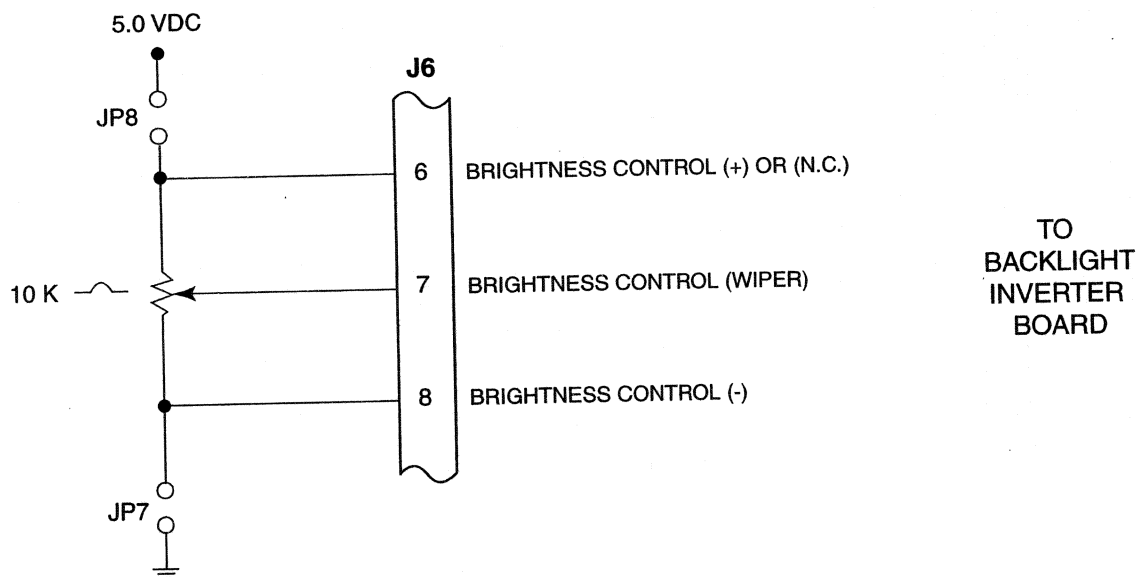

LD04054

NOTES:

1. J6-6 not connected (N.C.) to Backlight Inverter Board when display is manufactured by Sharp or NEC.
2. The position of Program Jumpers JP7 & JP8 determine the output at J6-7; In = Variable Voltage; Out = Variable Resistance. Refer to Program Jumper Listing in Table 1 for applications.
3. Potentiometer is actually an integrated circuit that is the electrical equivalent of a 10K potentiometer.

FIG. 10 – MICROBOARD LAMP DIMMER CIRCUIT

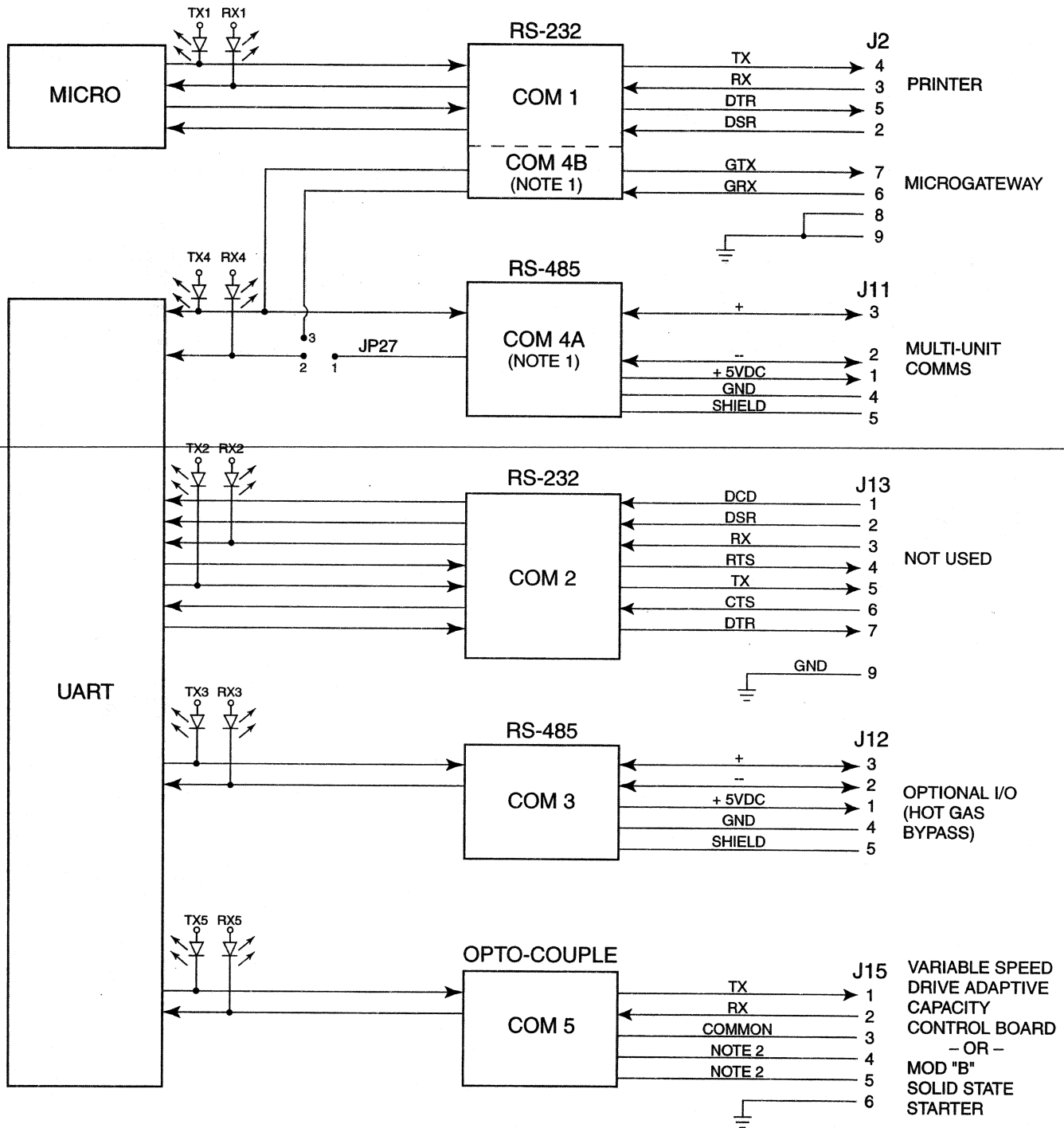

LD06523

NOTES:

1. Microboard Program Jumper JP27 determines whether COM 4A or 4B can be used. 1 & 2 - 4A, 2 & 3, 4B. Refer to Table 1.
2. J15-4 Loop-Around Test IN. J15-5 Loop-Around Test OUT. Refer to Fig. 66 for details.

FIG. 11 – MICROBOARD SERIAL DATA COMMUNICATIONS PORTS

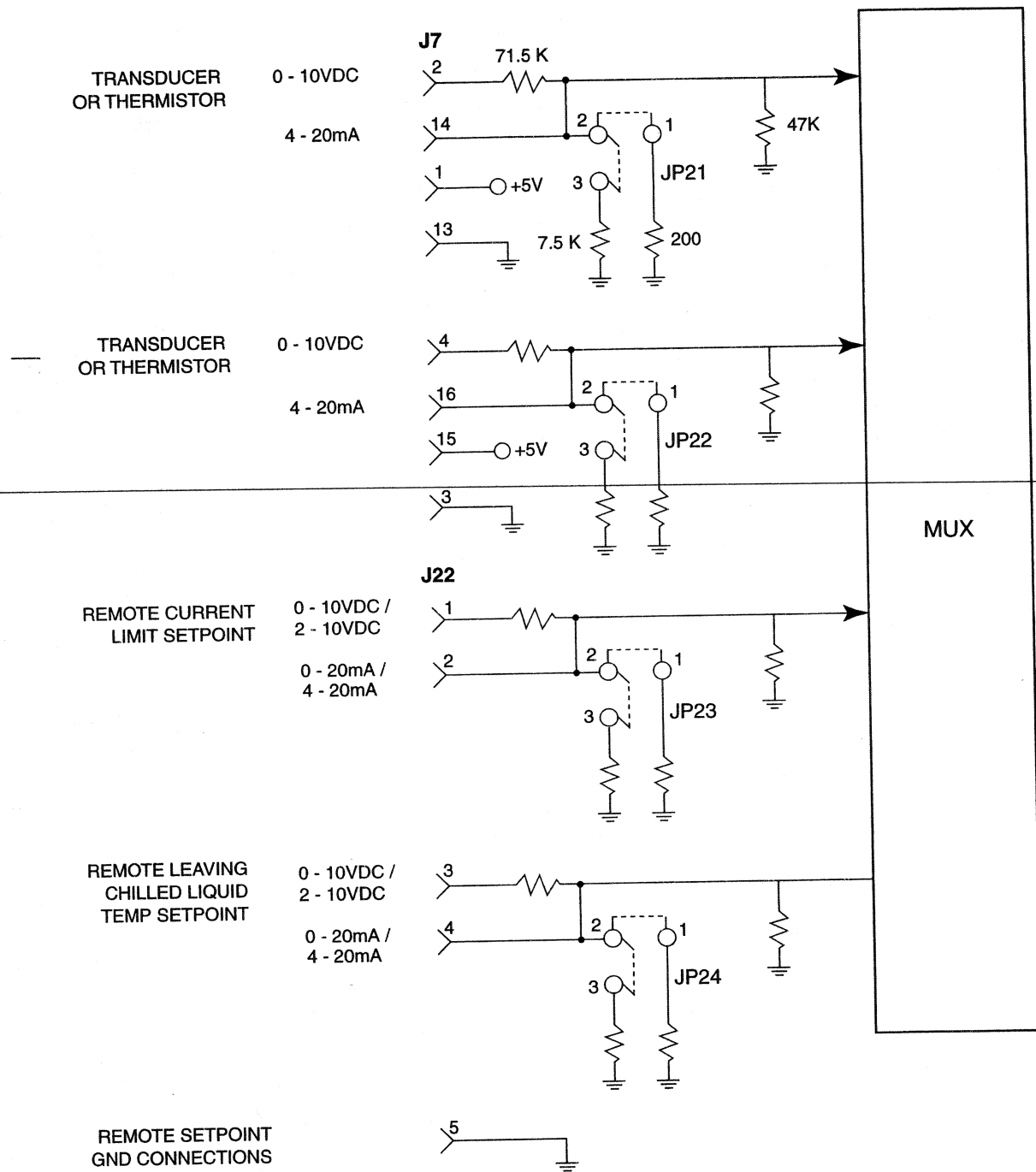

3

LD04636

NOTE:

1. Program Jumpers JP21 – JP24 must be positioned according to input signal type. Refer to Table 1.

FIG. 12 – CONFIGURABLE ANALOG & REMOTE SETPOINT INPUTS

SECTION 4

I/O BOARD

(REFER TO FIG. 13 - 17)

The **I/O (input/output) Board** conditions the Digital Inputs for the Microboard and conditions the Microboard's Digital Outputs for application to other components and devices. The left side of the I/O Board performs the Digital Inputs function; the right side performs the Digital Outputs function. Refer to Fig. 13.

Digital Inputs are on/off inputs to the Microboard from relay and switch contacts, such as flow switches, start/stop switch, and remote cycling/safety devices (ref. Fig. 14). The Micro reads the state of these contacts and reacts per the Program instructions. The contact voltage is 115VAC when closed and 0VAC when open. These voltages are not suitable for direct input to the Microboard. Therefore, the I/O Board converts the 115VAC/0VAC contact voltages to 0VDC/+5VDC logic level inputs for the Microboard. Individual Opto-coupler circuits (ref. Fig. 15) perform the conversion for each Digital Input. When the input is 115VAC, the output will be 0VDC; when the input is 0VAC, the output will be +5VDC.

Field connected Digital Inputs, such as those from external devices that cycle the chiller, are connected to terminal strip TB4 (ref. Fig. 14). These inputs are in the form of dry contacts connected as shown in Fig. 16. The 115VAC power source that is switched by the remote contacts is supplied by the I/O Board TB4-1. There are multiple TB4-1 terminals located adjacent to the field input connections, as shown in Fig. 13 and 14.

Digital Outputs are on/off outputs from the Microboard that control solenoid valves, motor contactors, actuators, system relays and provide operating status to external devices (ref. Fig. 17). Per Program instructions, the Microboard energizes and de-energizes these devices. The coils of these devices operate on 115VAC and therefore cannot be directly connected to the Microboard. The Digital Outputs section of the I/O Board contains +12VDC coil relays that are driven by the Microboard's logic level outputs. The contacts of these +12VDC relays operate the external 115VAC coil devices. On the I/O Board, one side of each of the relay coils is permanently connected to +12VDC at J19-26/27. The other side of each relay coil is connected to the Microboard via I/O Board connector J19. The Microboard energizes each relay by driving the appropriate input at J19 to logic low voltage level (ground potential). The DC voltage at the appropriate input pin

at J19 will be a logic high (>+10VDC) when the Microboard is commanding a relay to de-energize; logic low (<+1VDC) when commanding a relay to energize.

Relay K18 is different from all other relays on the I/O Board; it has a 115VAC coil. It provides the start/stop signal to the Compressor Motor Starter and provides **Compressor Run** status to remote devices (ref. Fig. 17). Relay K18 is controlled by DC relays K13 (start) and K14 (stop). To start the compressor motor, the Microboard energizes K13 and K14 simultaneously. The 115VAC at TB1-6 is applied to the coil of K18 via K13 contacts, energizing K18. Approximately 0.2 seconds later, K13 is de-energized. K18 remains energized through K14 contacts and holding contacts of K18. To stop the compressor motor, the Microboard de-energizes K14. To prevent sags in Utility Power from chattering K18, the holding contact of K18, along with the contact of K13, creates an anti-chatter circuit for relay K18. Once energized, K18 cannot be re-energized until K13 is again energized; this will not occur until after a controlled shutdown has occurred and another start sequence has been initiated.

There are conditions external to the I/O Board required to energize relay K18. The 115VAC will be present at TB1-16 only if the motor controller contacts "CM" are closed and the circuit between external Terminal Strip TB6-1 and TB6-53 is closed. The "CM" are located on the CM-2 Board (relay K1), Electro-Mechanical starter applications, the Solid State Starter Logic Board (relay K1), Solid State Starter applications or a relay mounted on the Variable Speed Drive Logic Board on Variable Speed Drive applications. The High Pressure safety switch "HP", must be closed and the RUN Switch "1SS" must be in the RUN position.

Triacs are used to control the Pre-Rotation Vanes Actuator and the Refrigerant Level Variable Orifice Actuator (ref. Fig. 17). An actuator has an open winding and a close winding. Current flowing through a winding will cause the actuator shaft to rotate in the respective direction. Each winding is controlled by a Triac. When a Triac is turned on, it permits current to flow through the actuator winding, causing the actuator shaft to rotate. Under Program control, the Microboard turns the Triacs on and off by applying control signals to the respective **Triac Driver**. The Triac Driver is an opto-coupler device that isolates the Microboard low

voltage circuits from the higher actuator voltages. To turn on the Triac, the Microboard drives the Triac Driver input to logic low (<+1VDC) level. The Triac driver responds by shorting the Triac GATE to Triac terminal 2. To turn the Triac off, the Microboard opens its input to the Triac Driver and allows the input to pull up to +12VDC. The Triac Driver responds by opening the short from triac Gate to Triac terminal 2. A voltmeter can be used to determine if a Triac is turned on or off. Measure across the Triac; from Triac terminal 1 to Triac terminal 2. When the Triac is turned off, the voltage will be approximately 20 to 30VAC; when turned on, it will be <10VAC.

The Pre-rotation Vanes Actuator has three windings; a Field winding and two direction windings. One direction winding produces clockwise rotation, the other produces counterclockwise rotation. The 115VAC applied to the Field Winding induces a 20 to 30VAC voltage into each of the direction windings. The desired rotation is produced by shorting the Actuator common terminal to the appropriate direction terminal, causing current to flow in the direction winding. As described above, Triacs control the current through the open and close windings.

The Refrigerant Level Variable Orifice Actuator has two windings; open and close. One winding produces clockwise rotation and one produces counterclockwise rotation. This actuator operates from 24VAC. As described above, Triacs are turned on to allow current to flow through the appropriate winding to produce the desired rotation.

RELAY TIMING

Under Program control, the relays are energized and de-energized producing contact operation as follows. Unless otherwise noted, contact rating is 5 amps resistive or 2 Amps inductive @ 250VAC.

K0 - Chilled Water Pump Starter (TB2-44/45)

Dry closure contacts. When the chiller is started, the Contacts close 13 seconds after the start of "System Prelube". Normally, they open coincident with the completion of **SYSTEM COASTDOWN** with the following exceptions:

- a. If a **LEAVING CHILLED LIQUID - LOW TEMPERATURE** cycling shutdown occurs, they do not open at the completion of **SYSTEM COASTDOWN**. They remain closed for the duration of the shutdown or until the Keypad **COM-**

PRESSOR switch is placed in the Stop-Reset (O) position, whereupon they open.

- b. If Microboard Program Switch SW1-8 is in the ON position, they do not open at the completion of **SYSTEM COASTDOWN** when the chiller shuts down on a **MULTIUNIT CYCLING - CONTACTS OPEN** or **SYSTEM CYCLING - CONTACTS OPEN** cycling shutdown. They remain closed for the duration of the shutdown or until the Keypad **COMPRESSOR** switch is placed in the Stop-Reset (O) position, whereupon they open.

K1 - Anticipatory Alarm (TB2-55/56)

Dry closure contacts. Contacts close when one of the following Warning messages is Displayed. On most warnings, the contacts automatically open when the warning condition is no longer present. On those warnings marked with an asterisk, the contacts will open only after the warning condition is no longer present and the **WARNING RESET** key is pressed when logged in at **OPERATOR** access level or higher.

Real Time Clock Failure, Condenser or Evaporator Transducer Error*, Refrigerant Level Out of Range, Standby Lube-Low Oil Pressure*, Setpoint Override*, Condenser-High Pressure limit, Evaporator-Low Pressure Limit, Excess Purge*, Vanes Uncalibrated - Fixed Speed, Harmonic Filter-Operation Inhibited, Harmonic Filter-Data Loss, Harmonic Filter-Input Frequency Out Of Range, Purge - High Pressure*, Purge - Float Switch Error*, Vanes Uncalibrated, External I/O - Serial Communications. Flash memory Card version C.MLM.02.02.xxx and later - (Excess Surge Detected*, Surge Detected - Excess Surge Limit, Purge Canister #1 Full*)

K2 - Remote Mode Ready to Start (only operational in Digital, Analog or ISN Remote mode)(TB2-26/27)

Dry closure status contacts that are closed to indicate to a Remote device that the chiller will start upon receipt of a remote start signal. The contacts open coincident with any Cycling or Safety shutdown or anytime the Keypad **COMPRESSOR** switch is placed in the Stop-Reset (O) position. On Cycling shutdowns, the contacts will close when the cycling condition clears. On safety shutdowns, the contacts will close only after the Safety condition clears, a manual reset is performed by placing the **COMPRESSOR** switch in the Stop-Reset (O) position and then back to the RUN (I) position.

K3 - Safety Shutdown Status (TB2-42/43)

Dry closure status contacts. They close coincident with a Safety shutdown. They remain closed until the safety

condition clears and a manual reset is performed by placing the **COMPRESSOR** switch in the **STOP-RESET (O)** position, whereupon they open.

K4 - Cycling Shutdown Status (TB2-40/41)

Dry closure status contacts. They close coincident with a Cycling shutdown. They remain closed until the cycling condition clears, whereupon they open.

K5 - Condenser Motor Pump Starter (TB2-150/151) (Flash Memory Card version C.MLM.02.01 and later)

Dry closure contacts. Contacts close coincident with beginning of "SYSTEM RUN". They open coincident with the beginning of "SYSTEM COASTDOWN" unless the chiller is equipped with the Mod "B" Solid State Starter. On Mod "B" Solid State Starter applications, the contacts remain closed at shutdown until all SCR Heatsink temperatures are $\leq 105^{\circ}\text{F}$ or a maximum of 45 minutes.

If it is desired to supply the dry contacts with 115VAC power from the OptiView Control Panel to control the Condenser Pump Motor Starter, a field installed wire must be connected from TB5-22 to I/O Board TB2-150. Then connect I/O Board TB2-151 to the Condenser Pump Motor Starter.

K6-K 10 - Not Used

K11 - Oil Pump Starter (TB 1-29/1)

In automatic operation, contacts close when **SYSTEM PRELUBE** is initiated. Contacts open at completion of **SYSTEM COASTDOWN**. In manual Oil Pump operation, the contacts close for the duration of manual pump operation. Anytime the chiller is not in **SYSTEM RUN** or **SYSTEM COASTDOWN** and a motor current value of $>15\%$ FLA is detected, the contacts close until motor current is no longer detected, whereupon a complete **SYSTEM COASTDOWN** is performed.

K12 - Purge Oil Solenoid (TB1-61)

Contacts close, energizing the Purge Oil Solenoid Valves, to place the Purge Tank in a fill cycle. A fill

cycle is initiated when both the Top and Bottom Purge Float Switches close, indicating the Purge Tank is empty. The contacts remain closed until both Purge Float Switches open, indicating the Purge Tank is full, whereupon the contacts open, performing a drain cycle.

K13 - Compressor Motor Starter (start) (TB1-6/16)

Contacts close coincident with the beginning of **SYSTEM RUN**. They remain closed for 0.2 seconds and then open.

K14 - Compressor Motor Stop (stop) (TB 1-6/16)

Contacts close coincident with the beginning of **SYSTEM RUN**. They remain closed for the duration of **SYSTEM RUN**. They open coincident with the beginning of **SYSTEM COASTDOWN**.

K15 - Vent Line Solenoid (TB1-34)

Contacts close five minutes after compressor motor start, energizing (opening) the Vent Line Solenoid Valve. Contacts open, de-energizing the valve, coincident with the beginning of **SYSTEM COASTDOWN**.

K16 - Purge Air Exhaust Solenoid (TB1-62)

Contacts close, energizing (opening) the Purge Air Exhaust Solenoid Valve when the Purge Tank Pressure increases to >90.0 (34.7) PSIA. The contacts subsequently open when the pressure decreases to <80.0 (29.7) PSIA. Pressures in parentheses are valid for non pump-assisted purge systems.

K17 - Condenser Motor Pump Starter (TB1- 164) (Flash Memory Card version C.MLM.02.00 ONLY)

Contacts operate the same as K14.

K18 - Compressor Motor Starter (TB5-22/25) Run Status (TB2-35/36)

Contacts operate the same as K14.

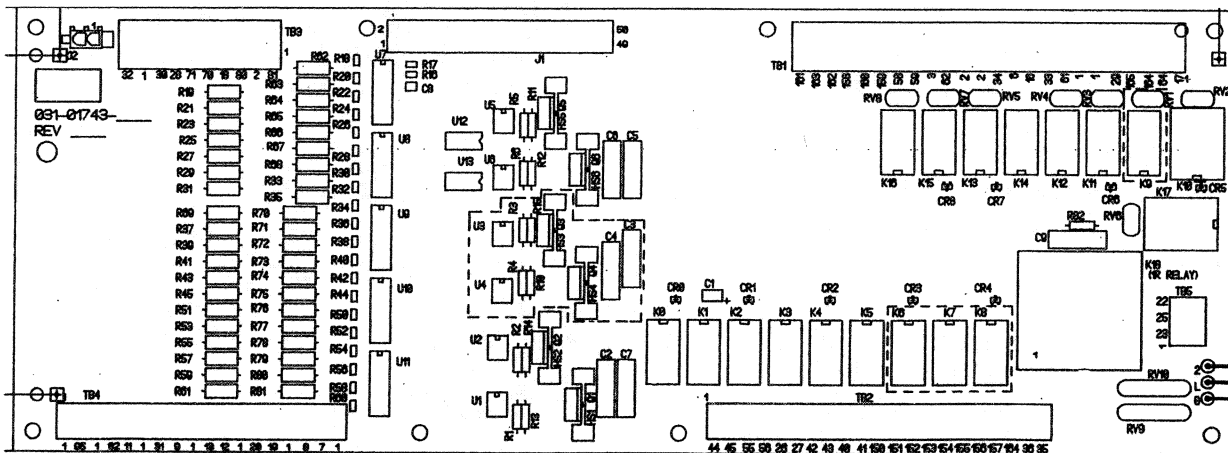
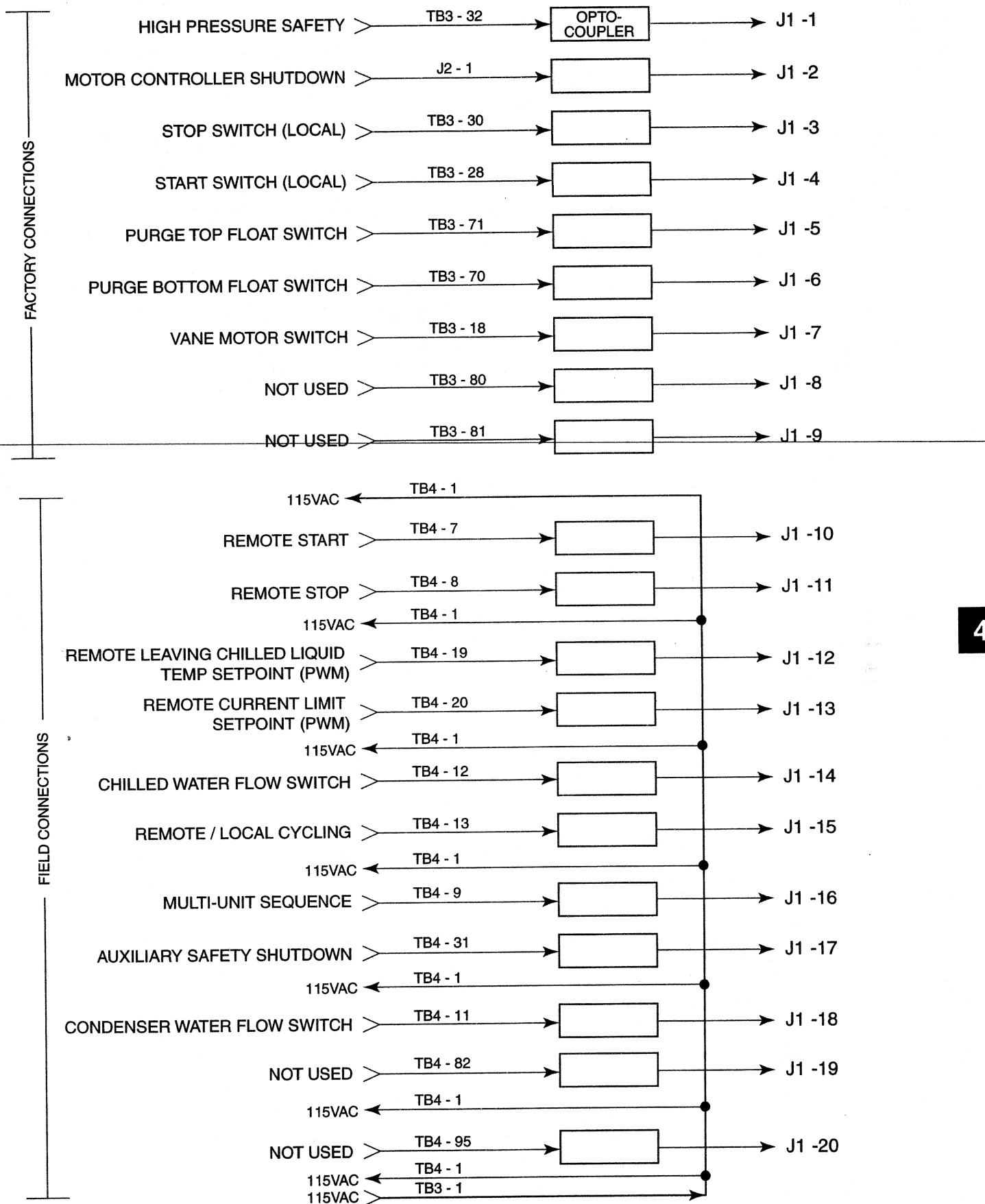

FIG. 13 – I/O BOARD

LD04055



4

FIG. 14 – I/O BOARD DIGITAL INPUTS

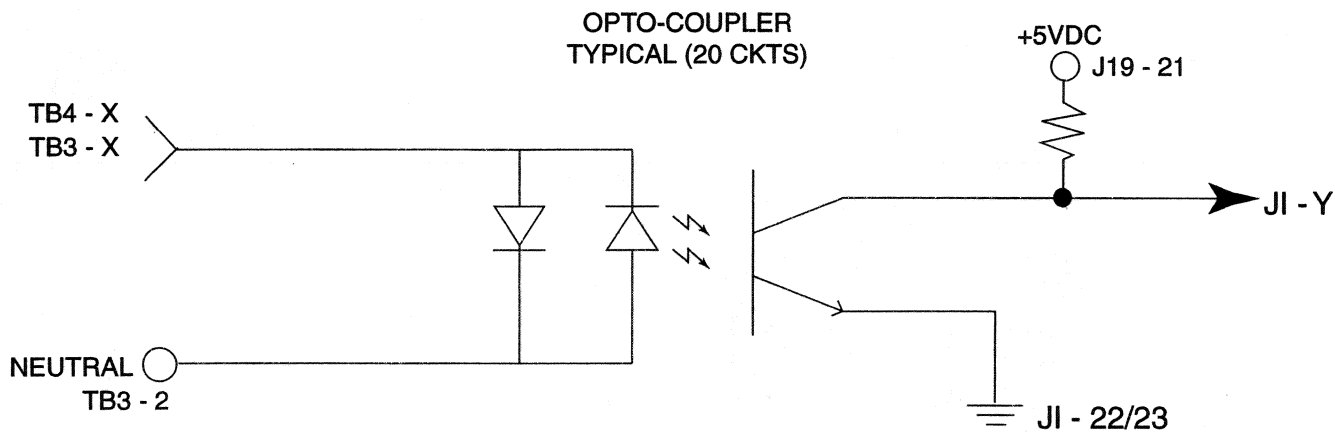

LD04057

FIG. 15 – I/O BOARD TYPICAL OPTO-COUPLER CIRCUIT

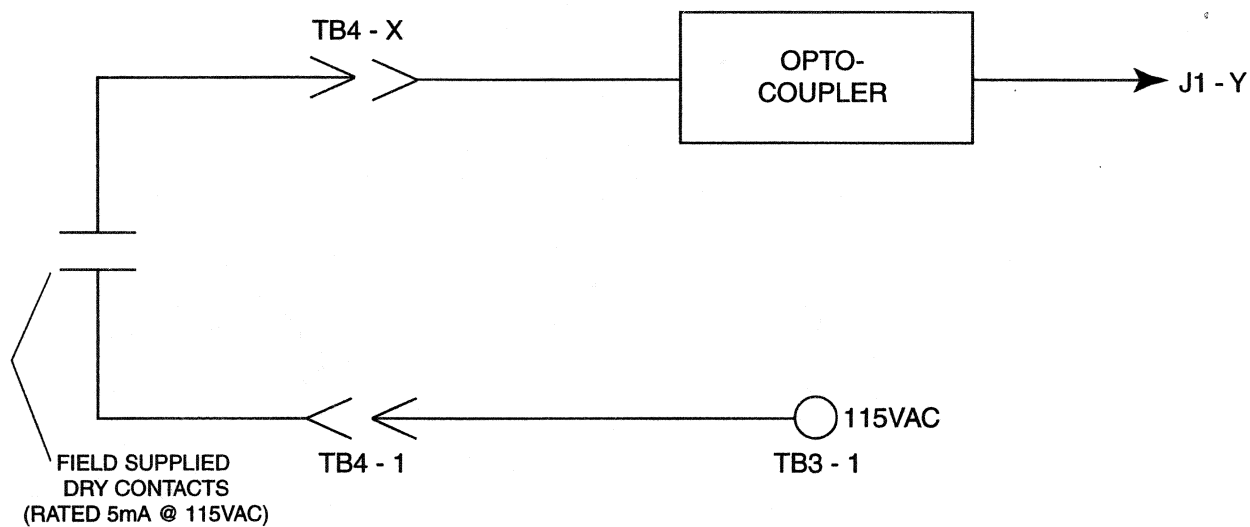

LD04058

FIG. 16 – I/O BOARD TYPICAL FIELD CONNECTIONS

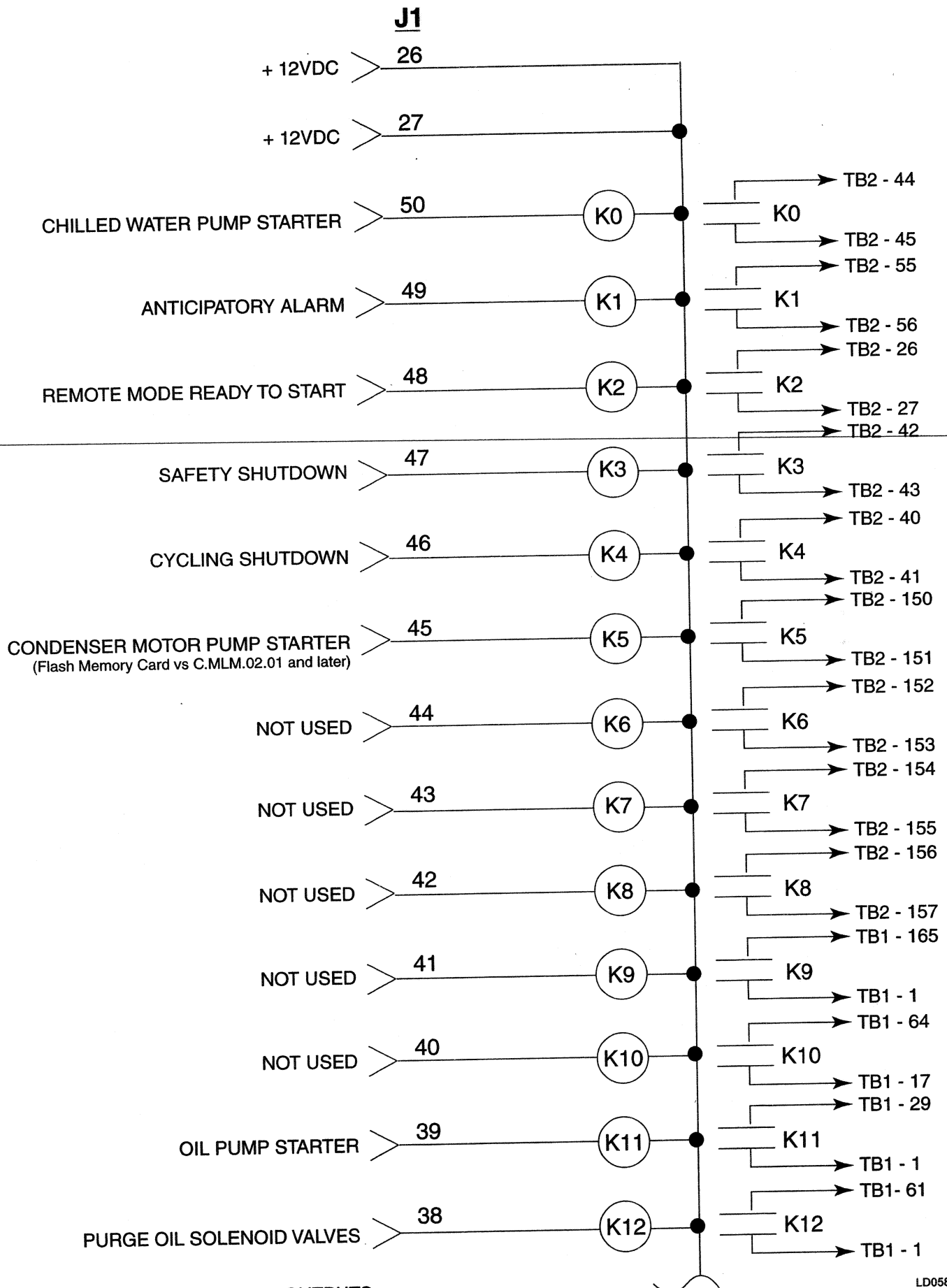

4

FIG. 17 - I/O BOARD DIGITAL OUTPUTS

LD05814

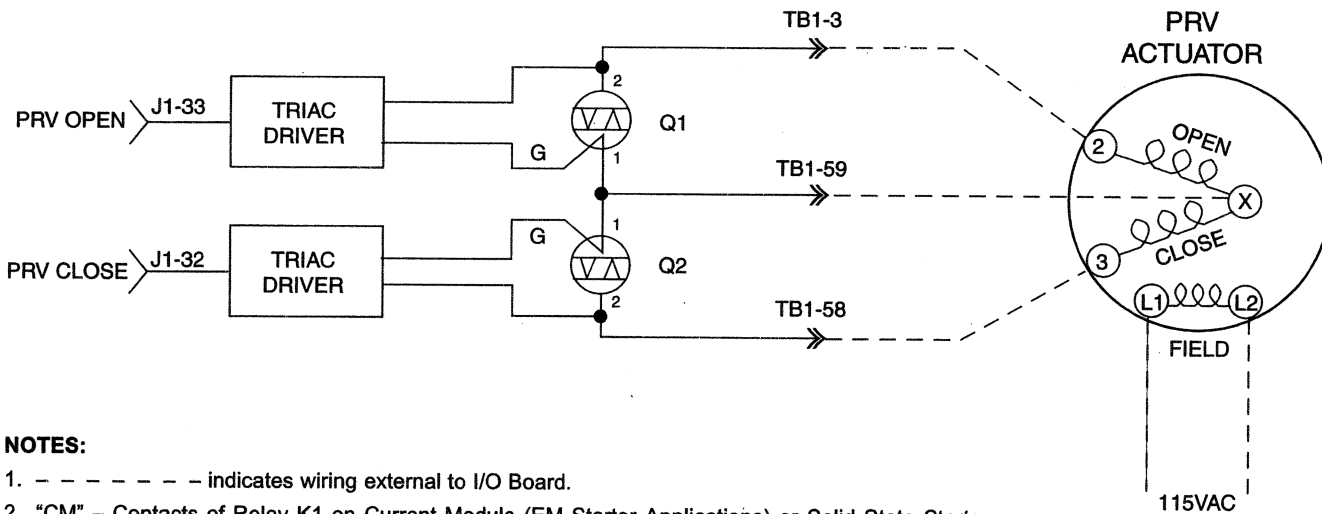
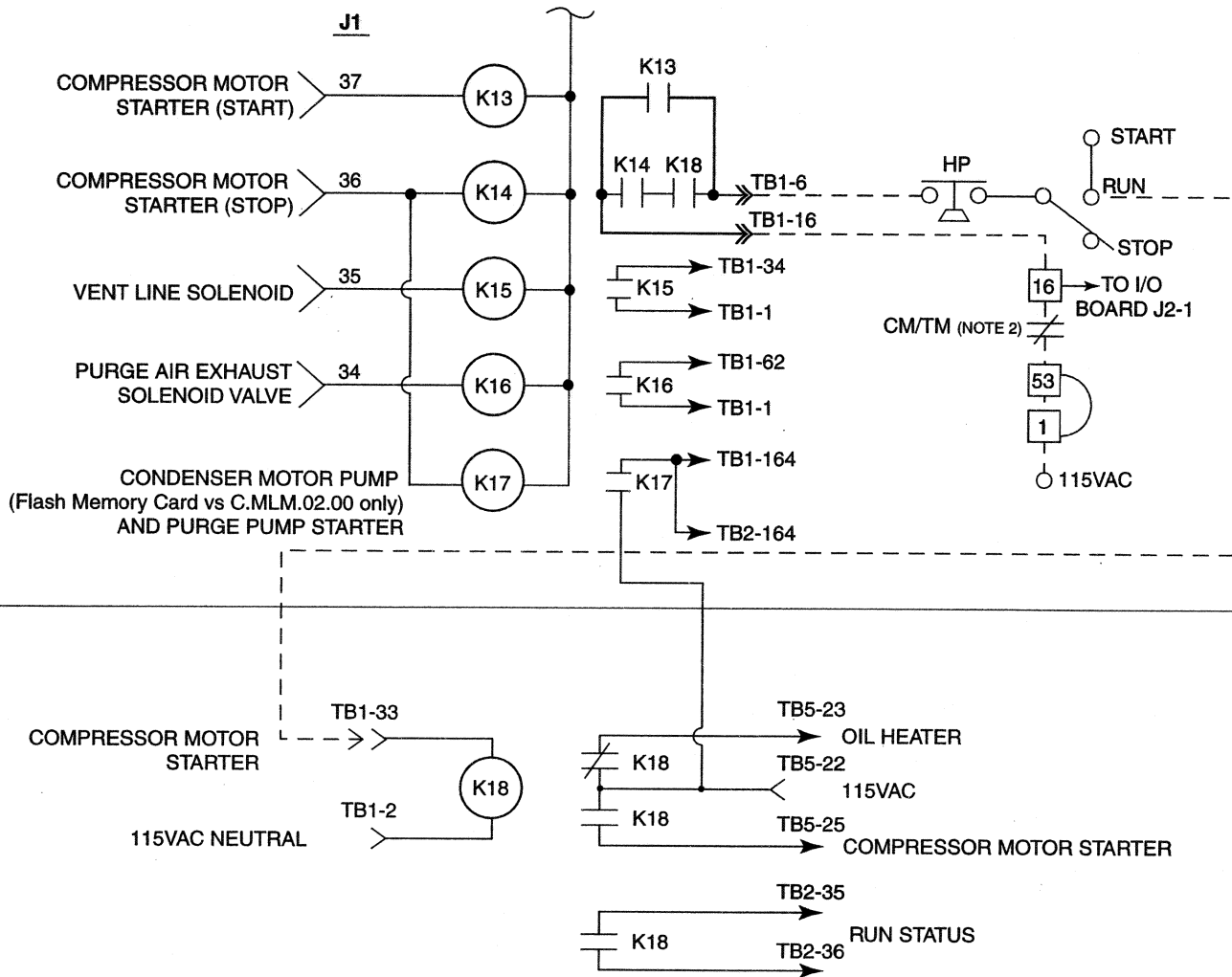

NOTES:

1. - - - - - indicates wiring external to I/O Board.
2. "CM" - Contacts of Relay K1 on Current Module (EM Starter Applications) or Solid State Starter Logic/Trigger Board (Solid State Starter Applications) or VSD Logic Board (Compressor Motor Variable Speed Drive Applications).

LD05815

FIG. 17 (CONT'D) - I/O BOARD DIGITAL OUTPUTS

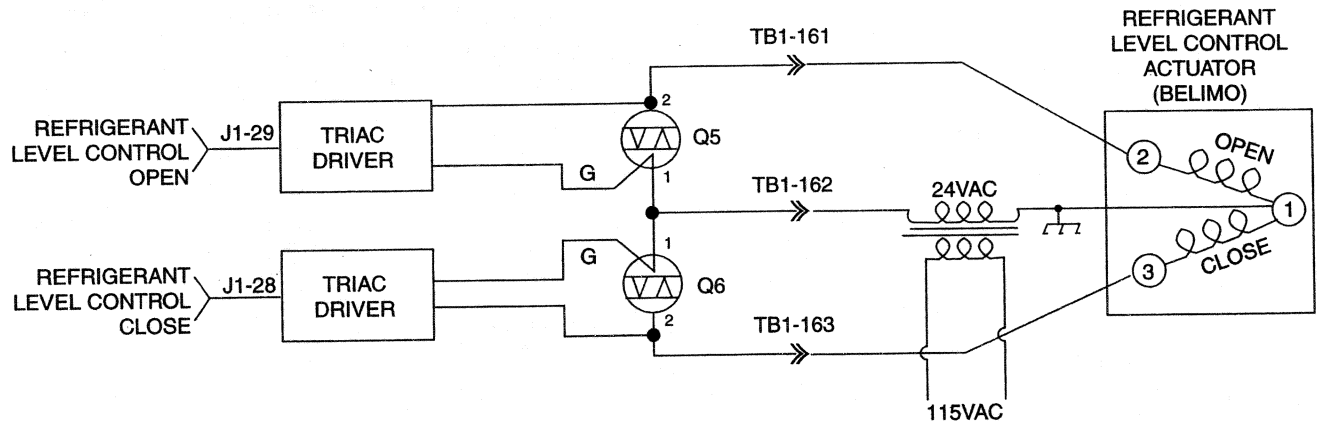
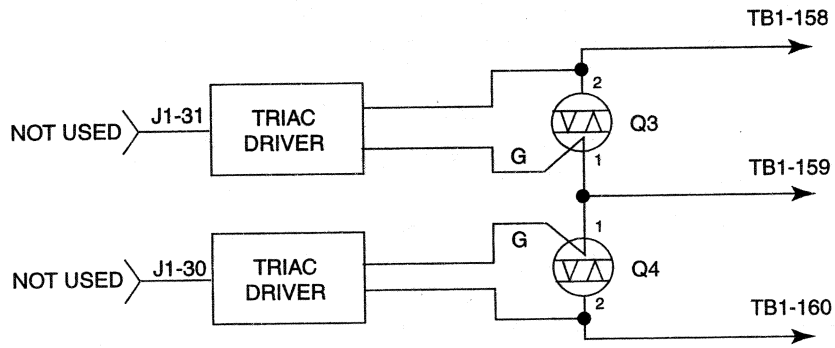

4

LD05816

FIG. 17 (CONT'D) - I/O BOARD DIGITAL OUTPUTS

SECTION 5

LIQUID CRYSTAL DISPLAY

(REFER TO FIG. 18 - 27)

A 10.4 inch color **Liquid Crystal Display**, along with supporting components **Display Interface Board** and **Backlight Inverter Board** are mounted on a plate that is attached to the OptiView Control Center door. A clear plexiglass faceplate prevents display surface damage. System operating parameters are displayed on various color graphic screens. The various display screens are selected for display using the Keypad keys.

The Display provided in the new chiller or from YORK as a service replacement part, could be manufactured by any of several approved manufacturers. Each Display requires a specific Display Interface Board, Backlight Inverter Board, Inverter Board interface cable and Program command set. **Therefore, Service replacement Displays or supporting components cannot be arbitrarily selected!!!** As explained below, replacement Displays are provided from YORK as kits to assure compatibility of all components. **Non-compatibility of components will result in incorrect operation!!!** Refer to "Display Interface Board" and "Backlight Inverter Board" sections that follow this section. Displays that could be provided from YORK in new chillers or as replacement parts are:

- SHARP LQ10D367
- SHARP LQ10D421
- NEC NL6448AC33-24
- LG SEMICON LP104V2-W

The YORK part numbers of the Display Interface Board, Backlight Inverter Board and Inverter ribbon cable provided, are listed on a label attached to the Display mounting plate. These are the part numbers of the supporting components that are compatible with the installed display. These supporting components can be individually replaced. However, if the Liquid Crystal Display fails, Display replacement kit 331-01771-000 must be ordered as detailed below. This kit contains a replacement Display and all compatible supporting components.

The Display has 307,200 pixels arranged in a 640 columns X 480 rows matrix configuration. Each pixel consists of 3 windows; red, green and blue, through which a variable amount of light from the Display Backlight is permitted to pass through the front of the display. Imbedded in each window of the pixel is a transistor, the conduction of which determines the amount of light

that will pass through the window. The conduction of each transistor is controlled by a signal from the Display Controller on the Microboard. The overall pixel color is a result of the gradient of red, green and blue light allowed to pass.

Under Program control, the Display Controller on the Microboard sends a drive signal for each pixel to create the image on the display. Each pixel's drive signal is an 18 bit binary word; 6 bits for each of the 3 colors, red green and blue. The greater the binary value, the greater the amount of light permitted to pass. The columns of pixels are driven from left to right and the rows are driven top to bottom. To coordinate the drive signals and assure the columns are driven from left to right and the rows are driven from top to bottom, each drive signal contains a horizontal and vertical sync signal. The **Display Interface Board** receives these display drive signals from the Microboard J5 and applies them to the Display at connector CN1. Refer to Fig. 28.

Although there are variations in control signal timing between different display manufacturers, Fig. 23 depicts typical control signals. Since these control signals occur at rates greater than can be read with a Voltmeter, the following description is for information only. There are 480 horizontal rows of pixels. Each row contains 640 3-window pixels. Beginning with the top row, the drive signals are applied within each row, sequentially left to right, beginning with the left most pixel and ending with the right most pixel. The rows are driven from top to bottom. The Vertical Sync (VSYNC) pulse starts the scan in the upper left corner. The first Horizontal Sync (HSYNC) pulse initiates the sequential application of RGB drive signals to the 640 pixels in row 1: Upon receipt of the **ENABLE** signal, an RGB drive signal is applied to the first pixel. As long as the **ENABLE** signal is present, RGB drive signals are then applied to the remaining 639 pixels at the CLK rate of 25.18MHz, or one every 39.72 nanoseconds. Typically it takes 31 microseconds to address all 640 pixels. Similarly, the next HSYNC pulse applies drive signals to row 2. This continues until all 480 rows have been addressed. Total elapsed time to address all 480 rows is approximately 16 milliseconds. The next VSYNC pulse causes the above cycle to repeat. Displays can be operated in **FIXED** mode or **DISPLAY ENABLE** mode. In **FIXED** mode, the first pixel drive signal is applied a fixed number (48) of clock (CLK) cycles from the end of the HSYNC pulse and the drive signals are termi-

nated a fixed number (16) of CLK cycles prior to the next HSYNC pulse. In **DISPLAY ENABLE** mode, the pixel drive signals are applied to the pixels only while **ENABLE** signal is present. This signal is typically present 4-48 CLKS after the end of the HSYNC pulse and 2-16 CLKS prior to the next HSYNC pulse. All YORK applications operate in the **DISPLAY ENABLE** mode. The state of the **ENABLE** (Display Interface Board J1-27) signal from the Microboard places the Display in the desired mode as follows:

- SHARP LDQ10D367 & LDQ10D421 Displays - When **ENABLE** maintained "low", display operates in fixed mode.
- NEC NL6448AC33-24 Displays - When **ENABLE** maintained "high" or "open", display operates in fixed mode.
- LG SEMICON Display does not have the fixed mode feature.

As described above, in OptiView Control Center applications, the Display scan is left to right, beginning with the top row and continuing sequentially through the rows to the last row. However, in Display applications other than OptiView Control Centers, image reversal is sometimes required. In image reversal applications, the scan is reversed; the scan is right to left, beginning with the last row and proceeding to the top row. The SHARP or NEC Display is placed in the **NORMAL** or **REVERSE** scan mode by the voltage levels on the Display Interface Board J1-30 and J1-31 (display connector CN1-30/31). These voltage levels are determined by the configuration of Wire jumpers P30 and P31 on the Display Interface Board (ref. Fig. 28). The Display reads these voltage levels and automatically assumes **NORMAL** or **REVERSE** scan operation. Refer to **DISPLAY INTERFACE BOARD** section that follows for jumper configurations.

Displays by different manufacturers can require different timing and control signals. The Microboard must know which Display is present in order provide the correct signals. Therefore, when AC control power is first applied to the OptiView Control Center, as part of the power-up sequence, the Microboard reads the Panel ID wire jumpers P1D0 - P1D3 on the **Display Interface Board** and determines which Display is present. It can then provide the correct timing and control signals to produce the graphic image, as required by the Display manufacturer. Since the **Display Interface Board** identifies the Display for the Microboard, there is a different **Display Interface Board** required for each Display application and each has a unique jumper configuration that identifies the Display. A complete explanation

YORK INTERNATIONAL

tion of this process is included in the preceding "Microboard" section and the "Display Interface Board" section that follows.

The DC power source to operate the Display is provided by the Microboard J5. Some Display manufacturers require +5VDC; others require +3.3VDC. The position of Microboard Program Jumper JP2 determines which of these power sources is supplied to the Display. JP2 must be positioned according to the Display manufacturers requirements. Refer to Table 1, "Program Jumpers".

The **Backlight Lamp** provides the illumination for the display. Average lamp life is 25000 hours (2.9 years). Some displays use one lamp. Others use two lamps. Lamps are replaceable, but not interchangeable between different displays. Each Display manufacturer specifies the required lamp for their display. Refer to replacement parts list for appropriate replacement lamp. Service replacement lamps are stocked in the YORK Service Parts Distribution Center. The lamp is illuminated by applying a high voltage AC (500 to 1500VAC) to it. This illumination voltage is created from a low level DC voltage (+12VDC or +5VDC as required by the Display manufacturer) by the **Backlight Inverter Board**. Lamp brightness is controlled by varying the high voltage AC. The greater the voltage the brighter the illumination. The lamp is controlled by on/off commands and brightness control signals applied to the **Backlight Inverter Board** from the Microboard. The Microboard Program determines when the lamp is turned on and off and the lamp brightness. Each Display manufacturer specifies the **Backlight Inverter Board** to be used. Therefore, it will vary according to the Display manufacturer. The ribbon cable that connects the Microboard to the Backlight Inverter Board also varies according to the Display manufacturer's requirements. Refer to Fig. 29 to 31. Microboard Program Jumpers JP3, 4, 5, 7 and 8 determine the voltage levels of the control signals sent to the **Backlight Inverter Board** and must be configured per the Display manufacturer's requirements as listed in Table 1. A detailed description of the operation of this board is in the "Backlight Inverter Board" section that follows. Also refer to the preceding "Microboard" section for a detailed description of the **Lamp Dimmer** circuit.

The actual Display that is installed in the OptiView Control Center of the new chiller is determined by the Display manufacturer contractual agreement in place during the time of OptiView Control Center production. Displays stocked for Service replacement are a result of that same agreement. Therefore, the Display received for service replacement may be by a different manufacturer than

the one in the OptiView Control Center. Since each Display manufacturer requires a specific Display Interface Board, Backlight Inverter Board and Inverter Ribbon Cable, replacement Displays are ordered and supplied as a Display Replacement Kit (YORK Part Number 331-01771-000) to assure component compatibility. The items supplied in the kit are compatible with the supplied Display. The kit consists of the following items mounted on a Display mounting plate:

Display Replacement Kit 331-01771-000:

1. Liquid Crystal Display with Lamp
2. Appropriate Display Interface Board for item 1
3. Appropriate Backlight Inverter Board for item 1
4. Appropriate ribbon cable (Backlight Inverter Board to Microboard) for item 1
5. Ribbon cable (Display Interface Board to Microboard)
6. All mounting hardware
7. Installation instructions. A label attached to the Display mounting plate lists the YORK part numbers of the Display supporting components mounted on the Display mounting plate and the required Microboard Program Jumper (JP2 through 8) configurations. **Microboard Program Jumpers JP2 - JP8 will have to be configured appropriately for the replacement display.**

Display Handling:

1. The display is made of glass. It could break if dropped.
2. The display front surface is easily scratched. If soiled, wipe with a dry cotton cloth. Use no water or chemicals.
3. The display is static sensitive. Electrostatic discharges may damage the display.
4. A laminated film is adhered to the display front glass surface to prevent it from being scratched. Peel off very slowly to prevent static damage.



Always remove control power from the OptiView control center before connecting or disconnecting wires to the display. Connecting or disconnecting wires to the display with power applied will damage the display!!!

BACKLIGHT LAMP REPLACEMENT:

SHARP LQ10D367 Display: (Refer to Fig. 29)

Removal:

The Lamp slides into the Display from left to right and is secured with a locking tab.

1. Remove Control Power from the OptiView Control Center.
2. Remove protective cover from rear of Display.
3. Disconnect Lamp AC power connector from Backlight Inverter Board.
4. Using fingernail or thin flat blade screwdriver, bend the locking tab outward slightly to clear the Lamp housing protrusion.
5. Grasp Lamp AC power connector and gently pull until Lamp housing clears locking tab.
6. Grasp Lamp housing and pull until Lamp housing is completely removed from the Display.

Installation:

1. Slide new Lamp into Display from left to right until Lamp housing protrusion locks into Display locking tab.
2. Connect Lamp AC power connector to Backlight Inverter Board.
3. Apply Control Power to OptiView Control Center.

SHARP LQ10D421 Display (refer to Fig. 30)

Removal:

Both the top and bottom lamps slide into the Display from left to right and are secured with locking tabs.

1. Remove Control power from the OptiView Control Center.
2. Remove protective cover from rear of display.
3. Disconnect lamp AC power connector from defective lamp.
4. Using a thin flat blade screwdriver, press in on the small black locking tab.
5. Grasp Lamp AC power connector and gently pull until Lamp clears locking tab.
6. Grasp Lamp housing and pull until Lamp housing is completely removed from the display.

Installation:

Follow instructions above for SHARP 367 Display.

NEC NL6448AC33-24 Display (refer to Fig. 31)

Removal:

Not available at this time.

Installation:

Not available at this time.

LG Semicon LP104V2-W Display (refer to Fig. 29)**Removal:**

The Lamp slides into the Display from left to right and is secured with a screw.

1. Remove Control Power from the OptiView Control Center.
2. Remove protective cover from rear of Display.
3. Disconnect Lamp AC power connector from Backlight Inverter Board.

4. Using small Phillips screwdriver, remove lamp retaining screw.
5. Grasp Lamp AC power connector and gently pull until Lamp housing is completely removed from the Display.

Installation:

1. Slide new Lamp into Display from left to right until Lamp housing is fully inserted.
2. Secure Lamp with Lamp retaining screw.
3. Connect Lamp AC power connector to Backlight Inverter Board.
4. Apply AC power to OptiView Control Center.

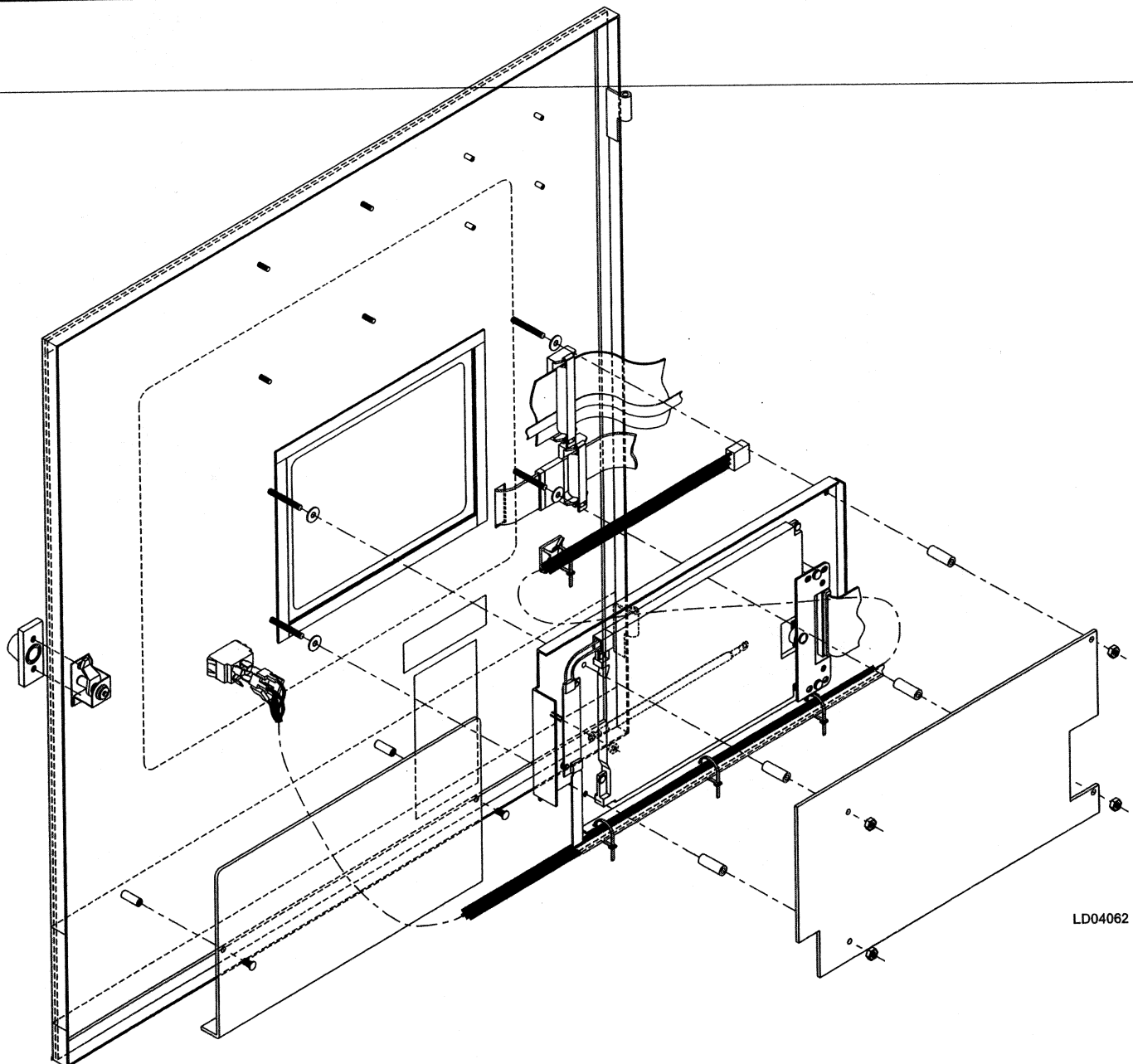
**FIG. 18 – DISPLAY, MOUNTING**

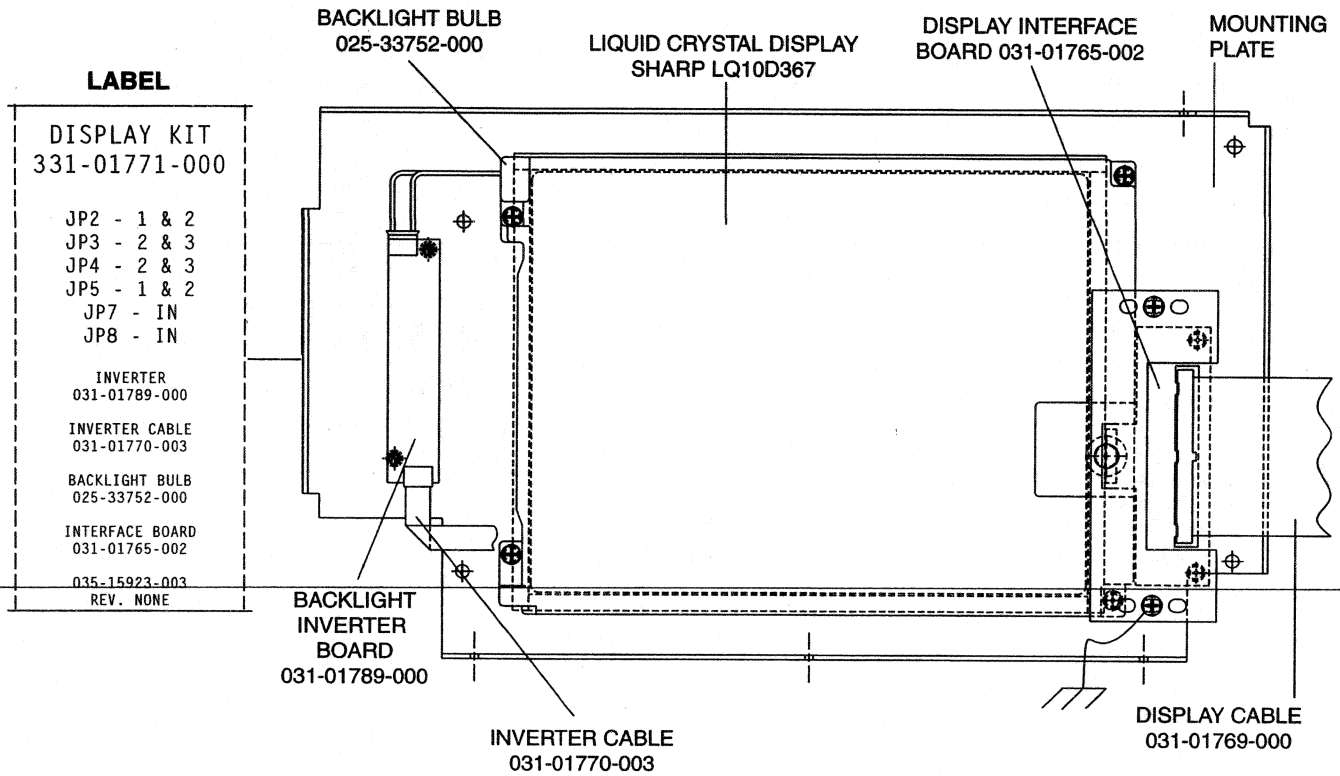

NOTE:

1. Configure Microboard Program Jumpers per label.

LD05817

FIG. 19 – LIQUID CRYSTAL DISPLAY ASSEMBLY – SHARP LQ10D367 DISPLAY

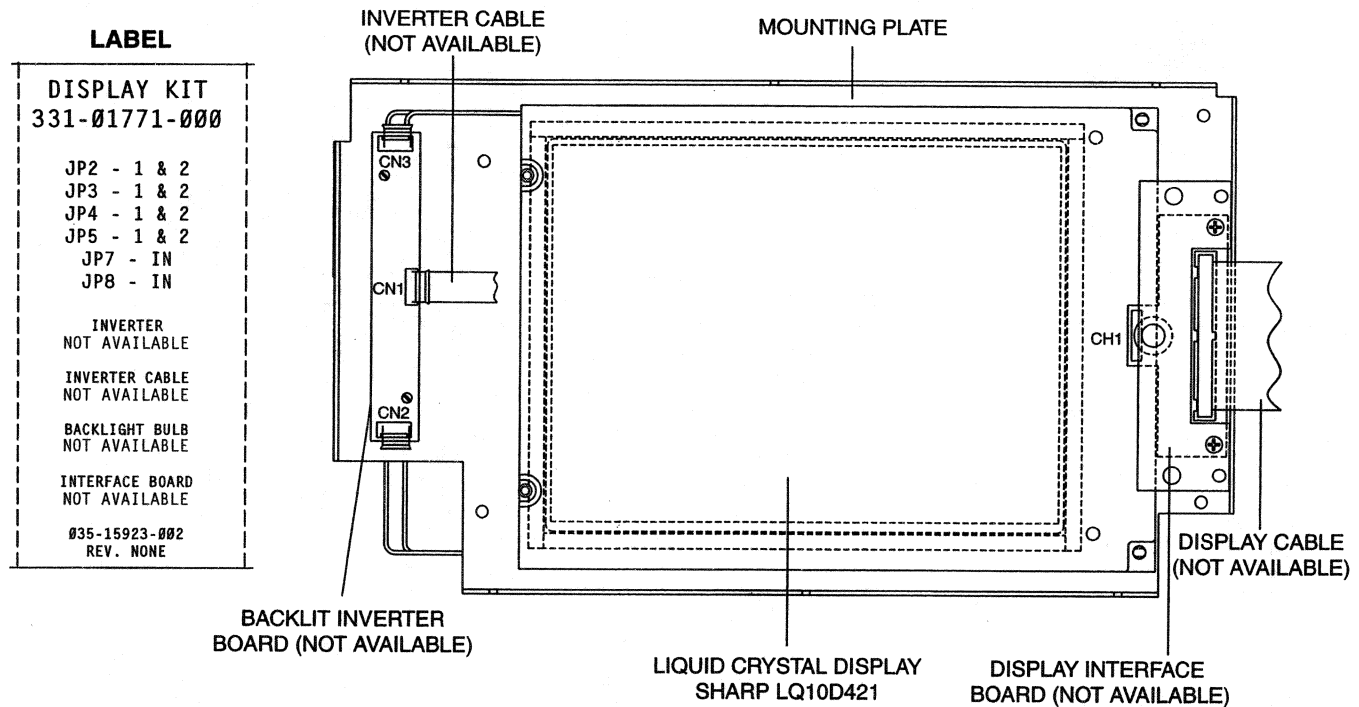

NOTE:

1. Configure Microboard Program Jumpers per label.

LD04064

FIG. 20 – LIQUID CRYSTAL DISPLAY ASSEMBLY – SHARP LQ10D421 DISPLAY

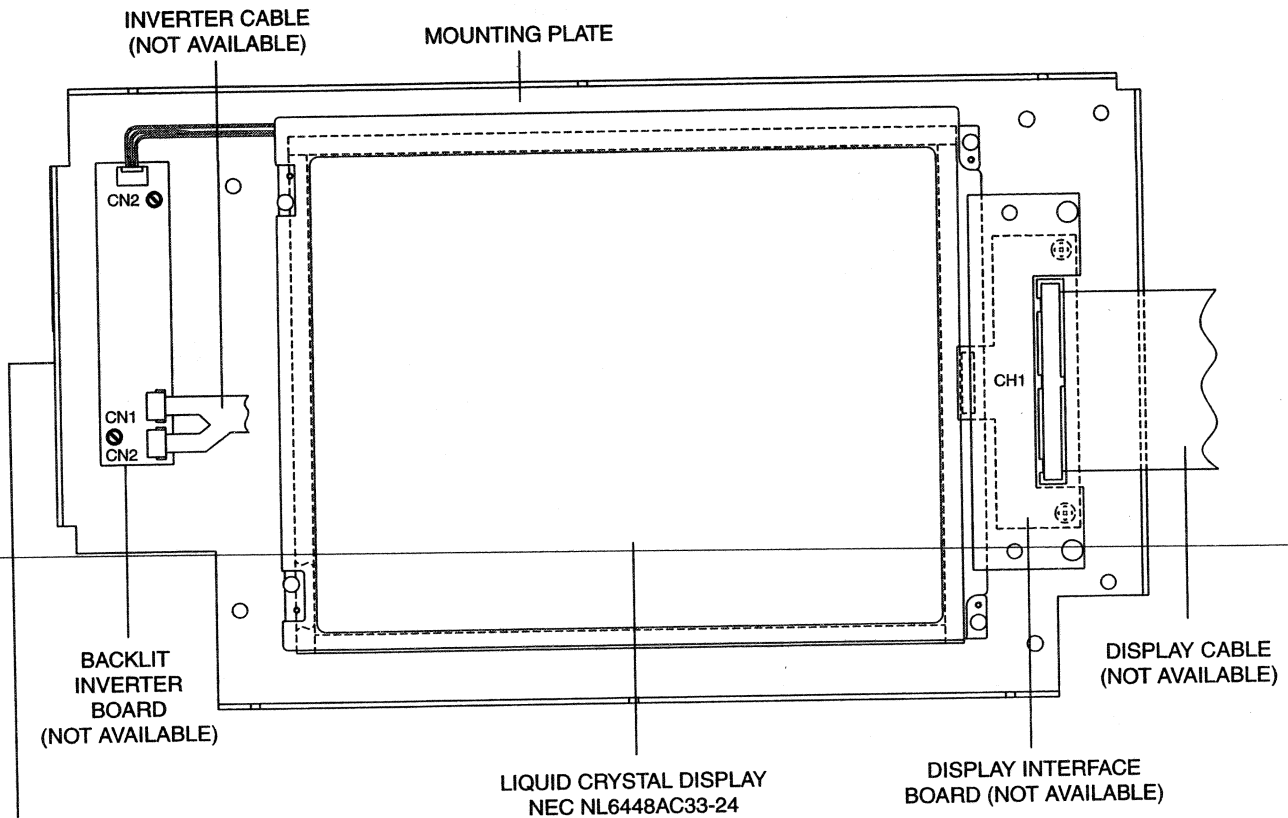

LABEL

DISPLAY KIT
331-01771-000

JP2 - 2 & 3
JP3 - 2 & 3
JP4 - 2 & 3
JP5 - 1 & 2
JP7 - OUT
JP8 - OUT

INVERTER
NOT AVAILABLE

INVERTER CABLE
NOT AVAILABLE

BACKLIGHT BULB
NOT AVAILABLE

INTERFACE BOARD
NOT AVAILABLE

035-15923-001
REV. NONE

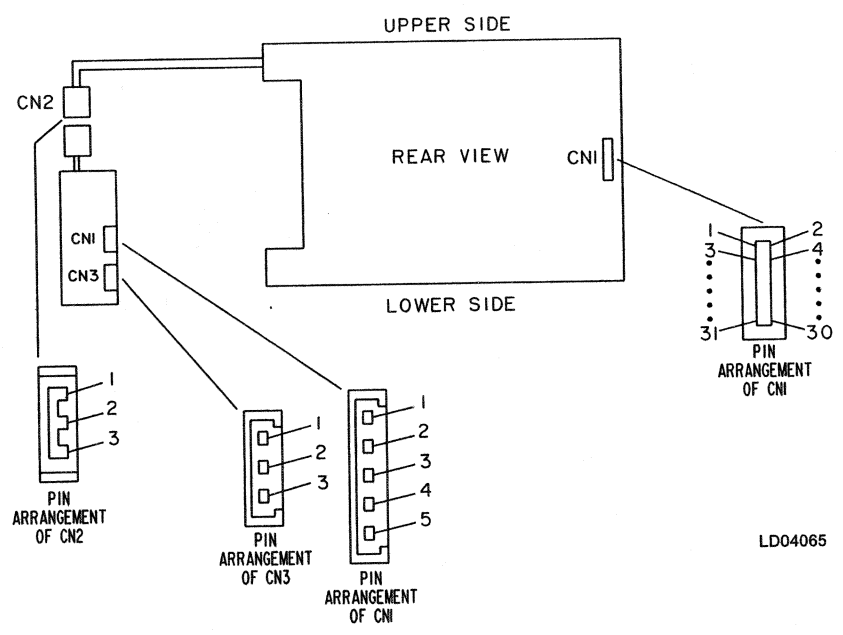

NOTE:
1. Configure Microboard Program Jumpers per label.

FIG. 21 - LIQUID CRYSTAL DISPLAY ASSEMBLY - NEC NL6448AC33-24 DISPLAY

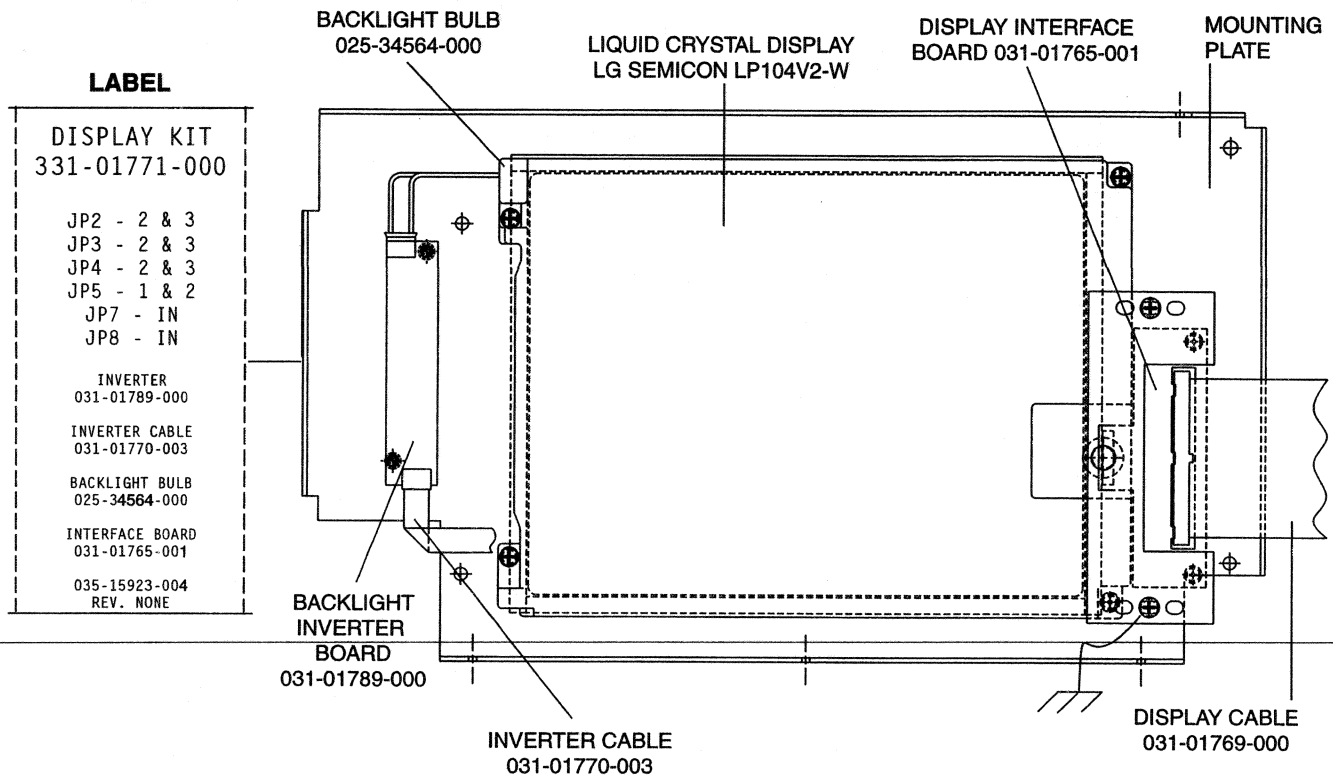

NOTE:

1. Configure Microboard Program Jumpers per label.

LD05818

FIG. 22 – LIQUID CRYSTAL DISPLAY ASSEMBLY - LG SEMICON LP104V2-W

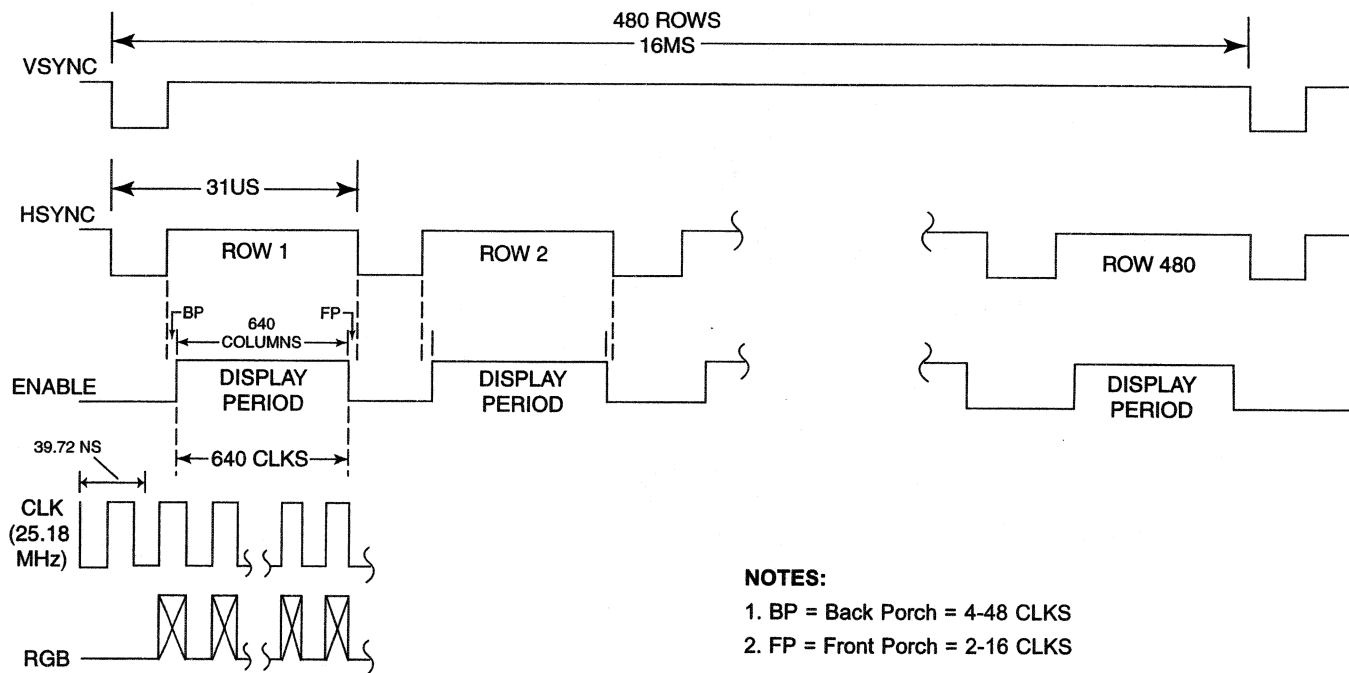

NOTES:

- 1. BP = Back Porch = 4-48 CLKS
- 2. FP = Front Porch = 2-16 CLKS

LD04066

FIG. 23 – LIQUID CRYSTAL DISPLAY TYPICAL CONTROL SIGNAL TIMING

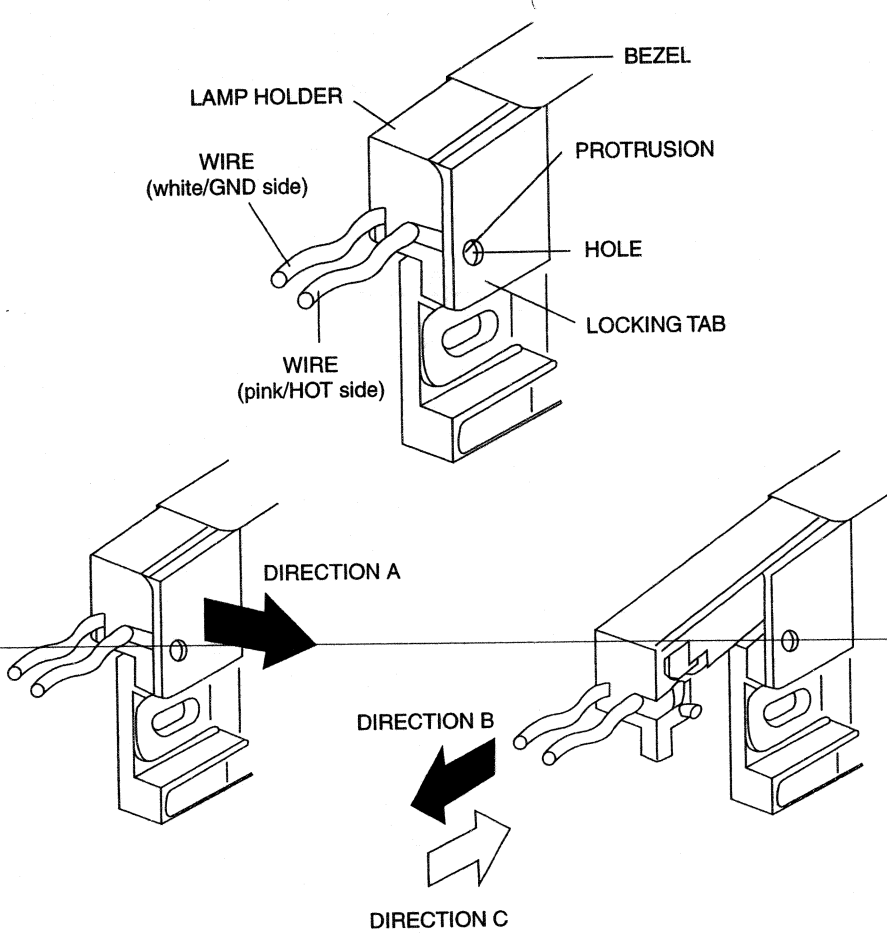

LD04067

FIG. 24 – DISPLAY (SHARP LQ10D367) LAMP REPLACEMENT

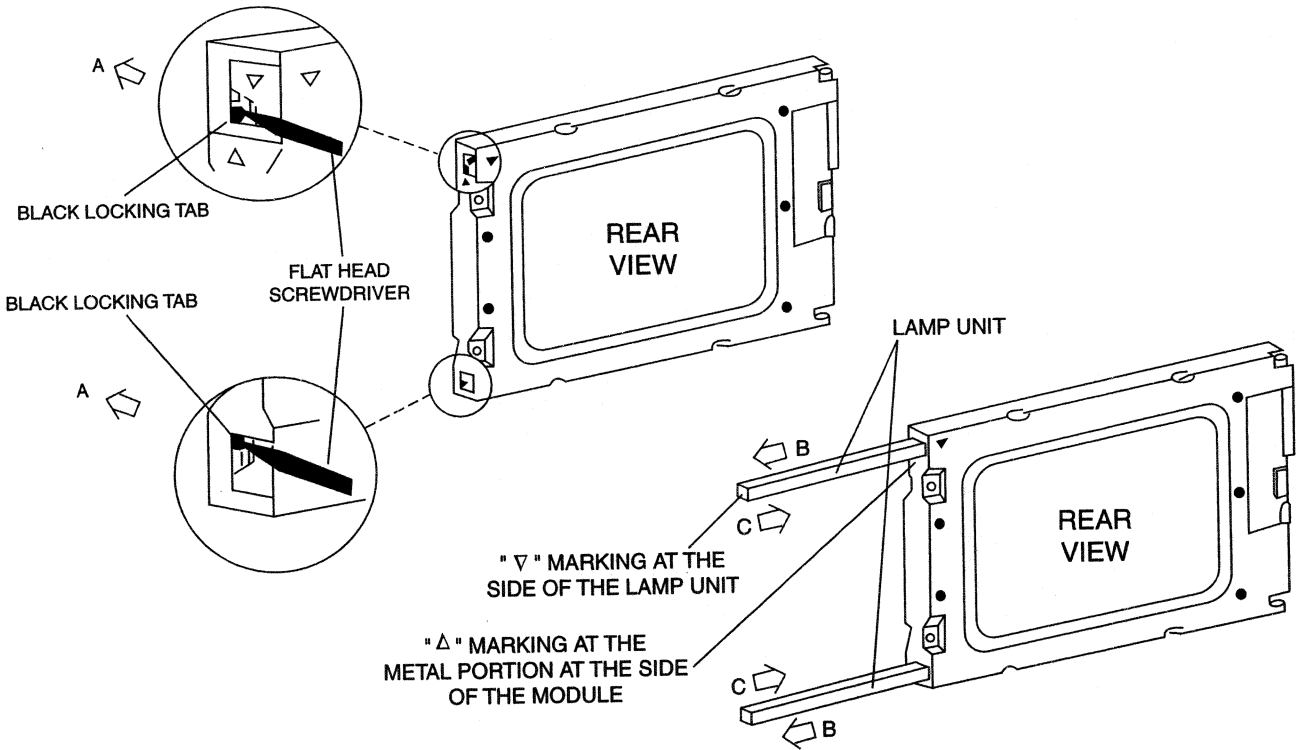

5

LD04068

FIG. 25 – DISPLAY (SHARP LQ10D421) LAMP REPLACEMENT

NOT AVAILABLE AT THIS TIME

LD04069

FIG. 26 – DISPLAY (NEC NL6448AC33-24) LAMP REPLACEMENT

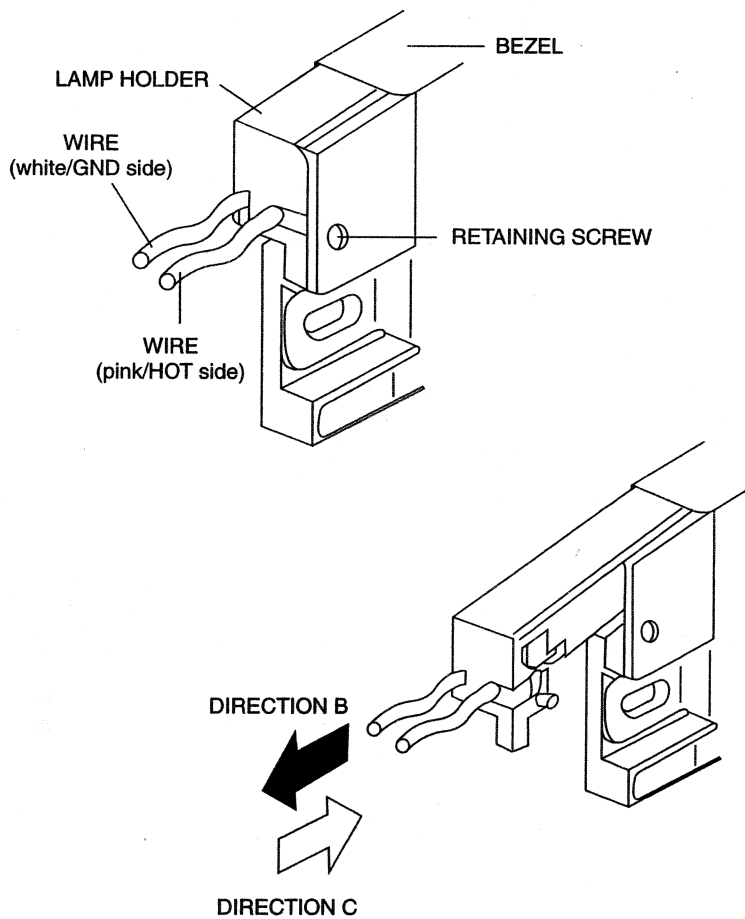

LD05819

FIG. 27 – DISPLAY (LG SEMICON LP104V2-W) LAMP REPLACEMENT

SECTION 6

DISPLAY INTERFACE BOARD

(REFER TO FIG. 28)

6

The **Display Interface Board** is located on the **Liquid Crystal Display** mounting plate and is part of the Microboard interface to the Display. It permits the use of Displays by different manufacturers, by providing the Microboard with a means of automatically determining which Display is present.

Since different Display manufacturers require different timing and control signals, the Display Controller on the Microboard must be configured to meet the requirements of the actual Display installed. When AC power is applied to the Control Center, as part of the power-up sequence, the Microboard reads the four Panel ID wire jumpers, P1D0 through P1D3, on the **Display Interface Board** to determine which Display is present. The configuration of these jumpers indicates the actual Display that is installed on the Control Center door. The Display Controller on the Microboard is then configured appropriately.

On Sharp and NEC displays the configuration of wire jumpers P30 and P31 determines whether the Display scan orientation is **Normal** or **Reverse** (image reversal) scan. As described in the preceding "Display" section, Normal scan is left to right, beginning with the top row and continuing sequentially through the rows to the bottom row. Normal scan is used in OptiView Control Center applications. In Display applications other than OptiView Control Center applications, image reversal is sometimes required. In image reversal applications, the scan is reversed; the scan is right to left, beginning with the bottom row and proceeding to the top row. The jumper configurations determine the voltage level at Display Interface Board J1-30 (P30) and J1-31 (P31). If P30 is IN, the voltage at J1-30 is +5.0VDC or +3.3VDC (as determined by position of Microboard Program Jumper JP2); if OUT, 0VDC. If P31 is IN, the voltage at J1-31 is GND; if OUT, 0VDC. The Display reads these voltages and adopts a scan mode as follows:

SHARP LQ10D367 & LQ10D421 Displays:

SHARP displays require configuration of both jumpers to achieve total image reversal.

- P30 IN - Normal scan; left to right
OUT - Reverse scan: right to left
- P31 IN - Normal scan; top to bottom
OUT - Reverse scan; bottom to top

NEC NL6448AC33-24 Display:

- P30 Not Used
- P31 IN or OUT - Normal scan; left to right, top to bottom

The wire jumpers on this board are not field configurable, as with typical Program Jumpers. There are two variations of the **Display Interface Board**. Each board has the wire jumpers configured appropriately for the display to which it is attached, as shown below. **Display Interface Boards** are available individually for service replacement. The YORK part number of the Display Interface Board compatible with the installed Display is listed on a label attached to the Display mounting plate. However, service replacement Displays are provided as a kit (331-01771-000) that includes, among other items, the appropriate **Display Interface Board** for the Display included in the kit. Refer to explanation in "Liquid Crystal Display" section.

031-01765-001:

- Display applicability - LG Semicon LP104V2-W & NEC NL6448AC33-24
- Jumper configuration - PID0 - IN
PID1 - OUT
PID2 - OUT
PID3 - OUT
P30 - OUT
P31 - OUT

031-01765-002:

- Display applicability - SHARP LQ10D367 & LQ10D421
- Jumper configuration - PID0 - OUT
PID1 - IN
PID2 - OUT
PID3 - OUT
P30 - IN
P31 - IN

The red, green and blue display drive and control signals are simply passed through the **Display Interface Board**. The value of VCC is either +5VDC or +3.3VDC, as determined by the position of Program Jumper JP2 on the Microboard. PID0 through PID3, when installed, connect their respective Microboard (J5) inputs to GND; when removed, the Microboard pulls these signals up to +5VDC. When P30 is installed, the Display input (CN1-30) is connected to VCC (+5VDC or +3.3VDC as determined by Microboard Program Jumper JP2). When P31 is installed, the Display input (CN1-31) is connected to GND.

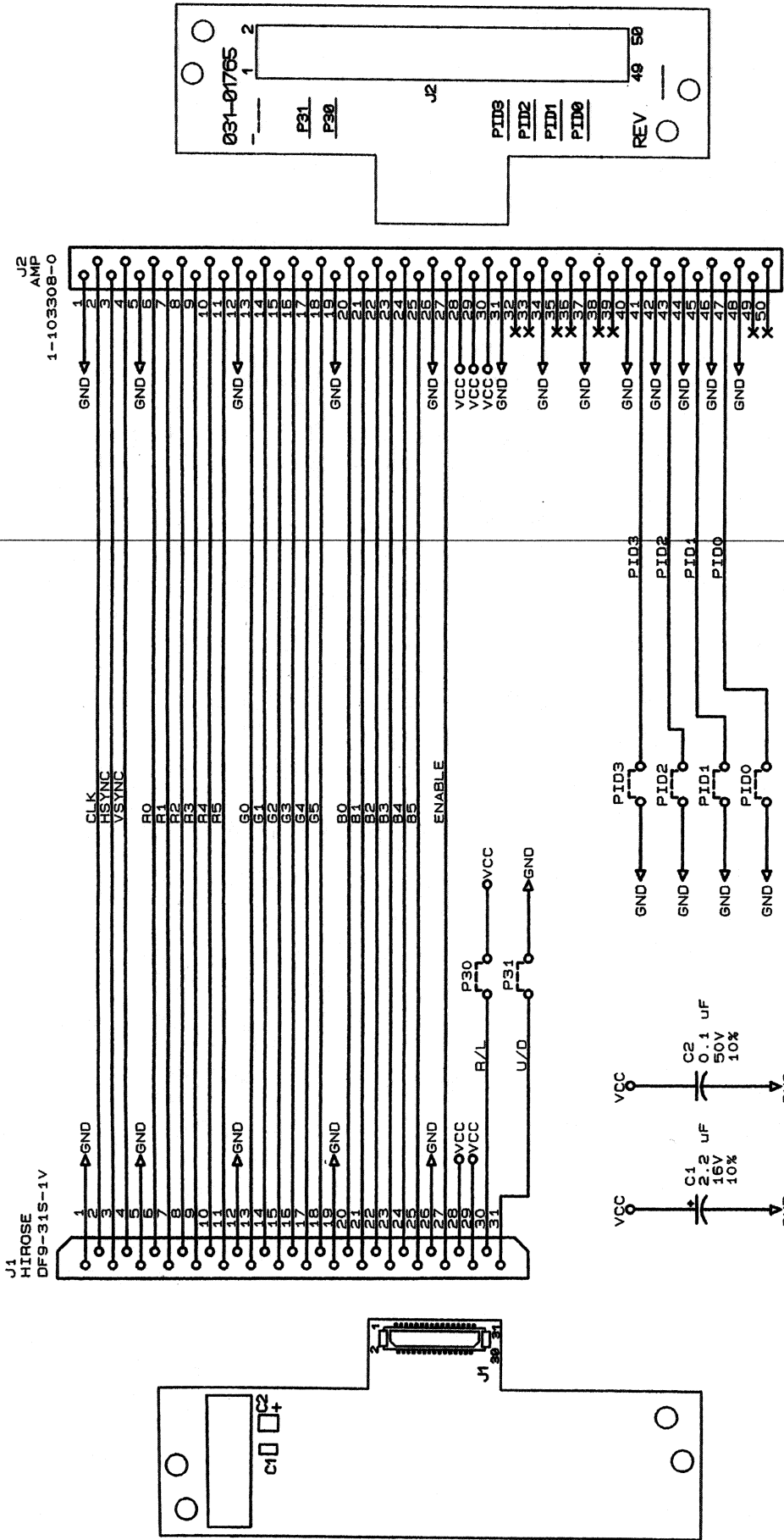

LG SEMICON LP104V2-W	031-01765-001	-	PID0	IN
NEC NL648AC33-24 DISPLAY			PID1-3	OUT
			P30, P31	OUT
SHARP LQ10D367 & LQ10D421 DISPLAYS	031-01765-002	-	PID0	OUT
			PID1	IN
			PID2, 3	OUT
			P30, 31	IN

LD04070

FIG. 28 - DISPLAY INTERFACE BOARD

THIS PAGE INTENTIONALLY LEFT BLANK
TO MAINTAIN FORMAT

SECTION 7

DISPLAY BACKLIGHT INVERTER BOARD

(REFER TO FIG. 29 - 31)

The **Display Backlight Inverter Board** generates a high voltage AC signal that is applied to the backlight lamp, causing it to illuminate. The magnitude of the signal determines the lamp brightness. Displays by some manufacturers have two lamps; one at the top and one at the bottom of the display. Other Display manufacturers have only a lamp at the top of the display.

An **Inverter** converts low level DC voltage (+12VDC or +5VDC, as required by the manufacturer) from the Microboard to a 500 to 1500VAC 60KHz signal that is applied to the lamp. The higher the AC voltage, the greater the brightness of the lamp. When this voltage is not present, the lamp is turned off.



High voltage, up to 1500VAC, is present at the output of the backlight inverter board. Refer to Figures 29 to 31 and locate the output connectors. Use extreme caution when working in this area!!!

Different Display manufacturers require different Backlight Inverter Boards. The different board designs require different control voltage inputs. To accommodate these variations, Microboard Program Jumpers JP3 - JP5, JP7 and JP8 must be configured to provide the required voltage levels. A label attached to the Display mounting plate lists the required Program Jumper configuration for that particular display. Refer to Table 1 for required Program Jumper configurations for the various Display applications.

Under Program control, the Microboard generates the control signals that are applied to the Backlight Inverter Board. The Program determines when the lamp is turned on and off. It also adjusts the lamp brightness. To increase the average lamp life of 25000 hours, the lamp brightness is normally adjusted to 50%. This brightness level will still allow the display to be visible. When the Program senses a Keypad key has been pressed, it adjusts the brightness to 100% (maximum).

The lamp illumination high voltage AC is generated from either +12VDC or +5VDC as required by the manufacturer. Microboard Program Jumper JP5 must be positioned to provide the required voltage. The

Microboard provides the **Backlight Enable** signal. This signal turns the lamp on and off. Some manufacturers require this signal to be +12VDC, others require +5VDC. Program Jumper JP4 must be positioned to provide the required voltage. Further, some applications require this signal to be a +VDC (+12VDC or +5VDC) to turn on the lamp. Others require this signal to be 0VDC to turn on the lamp. Program Jumper JP3 must be positioned to provide the required polarity.

Depending upon the Display manufacturer, the brightness control input from the Microboard must be either a variable voltage or a variable resistance. Microboard Program Jumpers JP7 and JP8 are used to provide the appropriate technique (refer to Fig. 10). The lamp dimmer circuit on the Microboard is an IC that is the electrical equivalent of a 10K ohm potentiometer with 100 positions or steps. The Program adjusts the position of the potentiometer. When configured for variable voltage (JP7 & JP8 installed), the output between Microboard J6-7 and J6-8 is a 0 to +5.0VDC signal. Not all applications require the full 5.0VDC range. If configured for variable resistance (JP7 and JP8 removed), the output between Microboard J6-7 and J6-8 is a 0 to 10K ohm variable resistance.

The Control Center could be supplied with any of several approved Displays. Each Display requires a specific Backlight Inverter Board as specified below and in Figures 29 to 31. These boards are individually available as service replacement parts (the required Backlight Inverter Board part number is listed on the label attached to the Display mounting plate). However, service replacement Displays are provided in a kit (YORK P/N 331-01771-000) that includes the appropriate Backlight Inverter Board (refer to "Liquid Crystal Display" Section).

SHARP model LQ10D367 and LG Semicon LP104V2-W displays require a TDK CXA-LO612-VJL Backlight Inverter Board (YORK P/N 031-01789-000) (ref. Fig. 29). These boards generate a lamp illumination high voltage AC from +12VDC. When the Backlight Enable signal at connector CN1-3 is +5VDC, the high voltage signal is applied to the lamp. When CN1-3 is 0VDC, the high voltage signal is removed from the lamp, turning it off. The lamp brightness is controlled by a variable voltage signal, developed by the lamp dimmer circuit (ref. Fig. 10) on the Microboard

and applied to connector CN1-4. The lamp dimmer circuit varies the voltage at CN1-4 over the range of 0 to +3.0VDC. 0VDC produces maximum (100%) brightness; +3.0VDC produces minimum (0%) brightness. Voltages between these values produce a linear brightness 0 and 100%. Connector CN2 applies the high voltage lamp illumination signal to the lamp.

SHARP model LQ10D421 displays require a XENTEK LS520 Backlight Inverter Board (YORK P/N XXX-XXXXX-XXX) (refer to Fig. 30). These boards generate the lamp illumination high voltage AC from +12VDC. When the "Backlight Enable" signal at connector CN1-5 is 0VDC, the high voltage signal is applied to the lamp, turning it on. When CN1-5 is +12VDC, the high voltage signal is removed from the lamp, turning it off. The lamp brightness is controlled by a variable voltage signal, developed by the lamp dimmer circuit (ref. Fig. 10) on the Microboard and applied to connector CN1-6 and CN1-7. The Microboard places CN1-7 at ground (GND) potential. The lamp dimmer varies the voltage at CN1-6 over the range of 0 to +2.5VDC. 0VDC produces maximum (100%) lamp brightness; 2.5VDC produces minimum (0%) brightness. Voltages between these values

produce a linear brightness between 0 and 100%. This display has a lamp at the top of the display and one at the bottom of the display. Connector CN2 applies the high voltage lamp illumination signal to the lower lamp; CN3 the upper lamp.

NEC model NL6448AC33-24 displays require an NEC 104PWBR1 Backlight Inverter Board (YORK P/N XXX-XXXXX-XXX) (refer to Fig. 31). These boards generate the lamp illumination high voltage AC from +12VDC. When the **Backlight Enable** signal at connector CN3-1 is +5VDC, the high voltage signal is applied to the lamp, turning it on. When CN3-1 is 0VDC, the high voltage signal is removed from the lamp, turning it off. The lamp brightness is controlled by a variable resistance, developed by the lamp dimmer circuit (ref. Fig. 10) on the Microboard and applied to connector CN3-2 and CN3-3. The lamp dimmer varies the resistance between CN3-2 and CN3-3 over the range of 0 to 10K Ohms. 0 Ohms produces minimum (0%) brightness; 10K Ohms produces maximum (100%) brightness. Resistances between these extremes produce linear brightness between 0% and 100%. Connector CN2 applies the high voltage lamp illumination signal.

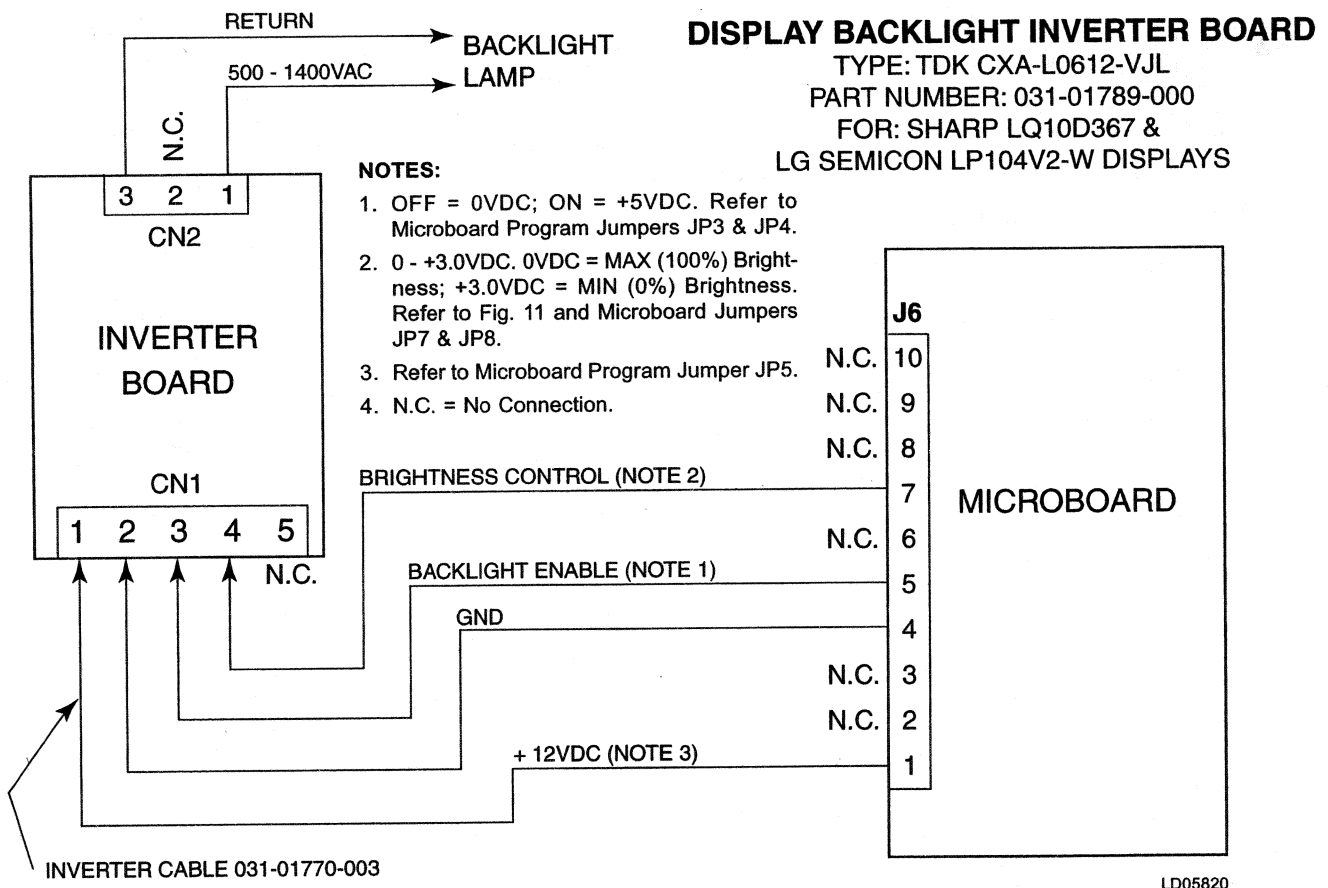
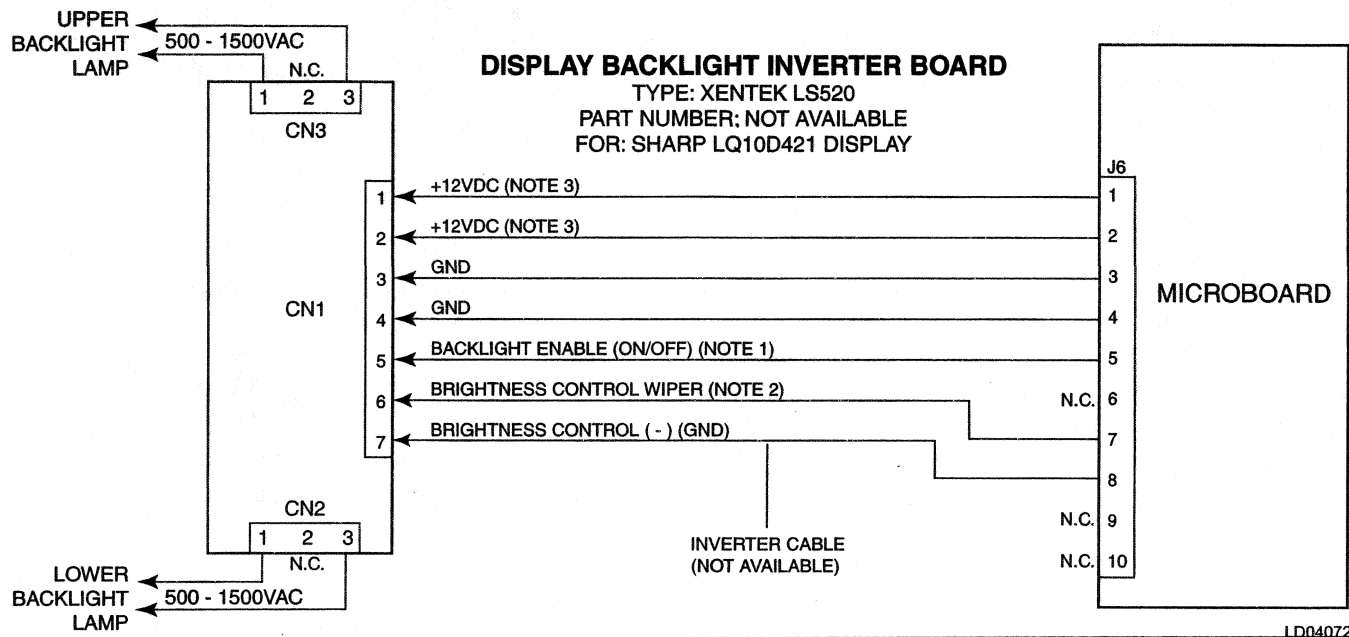

FIG. 29 – DISPLAY BACKLIGHT INVERTER BOARD (SHARP LQ10D367 & LG SEMICON LP104V2-W)

Display Backlight Inverter Board



NOTES:

1. ON = 0VDC; OFF = +12VDC. Refer to Microboard Program Jumpers JP3 & JP4.
2. 0 - +2.5VDC. 0VDC = MAX (100%) Brightness; +2.5VDC = MIN (0%) Brightness. Refer to Fig. 9 and Microboard Program Jumpers JP7 & JP8.
3. Refer to Microboard Program Jumper JP5.
4. N.C. = No Connection.

FIG. 30 – DISPLAY BACKLIGHT INVERTER BOARD (SHARP LQ10D421)

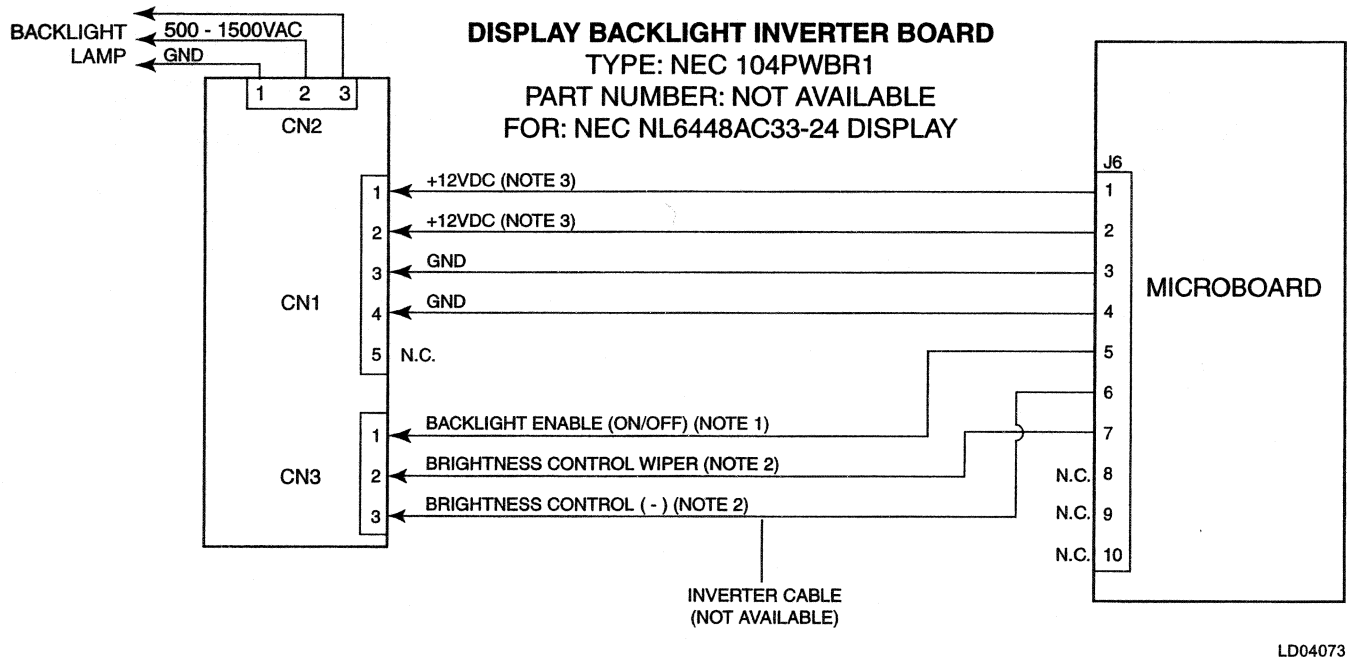

NOTES:

1. ON = +5VDC; OFF = 0VDC. Refer to Microboard Program Jumpers JP3 & JP4.
2. 0 - 10K Ohms. 0 Ohms = MIN (0%) Brightness; 10K Ohms = MAX (100%) Brightness. Refer to Fig. 9 and Microboard Program Jumpers JP7 & JP8.
3. Refer to Microboard Program Jumper JP5.
4. N.C. = No Connection.

FIG. 31 – DISPLAY BACKLIGHT INVERTER BOARD (NEC NL6448AC33-24)

SECTION 8

KEYPAD

(REFER TO FIGURES 32 & 33)

The **Keypad** contains touch-sensitive keys that allow the Operator to interface with the Control Center. The Operator presses the keys to request the desired screens of information and enter System Setpoints.

The top layer of the Keypad contains embossed areas identifying the keys. Under each embossed key area are two conductors, one on top of the other, separated by an air space. The conductors are arranged in a matrix of rows and columns and connected to the Keypad connector as shown in Fig. 32. The embossed area of each key is located directly over the intersection point of the conductors. Pressing the embossed key area causes contact and electrical continuity between the two conductors. For example, pressing the "1" key creates continuity between the Keypad connector pin 5 (column 3) and pin 13 (row 4). Since this connector is interfaced to the Microboard (J18), the Microboard senses this continuity as described below and concludes the "1" key is pressed.

The Microboard Program continuously scans the Keypad to determine if a key is pressed. Beginning with row 1 and proceeding through all rows, the Program places a "logic low" (<1VDC) on a row, a "logic high" (>4VDC) on the remaining rows and reads the columns. A logic low in any column indicates a key in that column and row is pressed. For example, if at the time row 4 is being driven low, if column 3 is low, then the

Micro concludes the key at coordinate of row 4 and column 3 is pressed. Since the coordinates of all keys are stored in the Microboard's Program, it can identify which key is at this coordinate and responds accordingly. In this example the "1" key is pressed.

In order for the Microboard to reliably detect closed and open keys, each key must meet a closed circuit and open circuit resistance requirement. When a key is pressed, the contact resistance must be ≤ 100 Ohms. When a key is not pressed, the contact resistance must be ≥ 1 Meg Ohm. If the Microboard is not responding to a pressed key, or if it's detecting a closed key when none are pressed, it could be because the contact resistance requirements are not being met. The operation of each key can be checked with an Ohmmeter. To check the open and closed contact resistance of any key, refer to the "Diagnostics and Troubleshooting" Section 23 of this book.

The Keypad is attached to the front of the Control Center door with an adhesive backing. If service replacement is required, start at one corner and slowly peel the Keypad from the door. The rear side of the replacement Keypad is coated with an adhesive covered with a paper backing. Remove the paper backing, align the Display and rocker switch openings and apply the Keypad to the door.

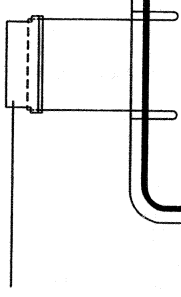
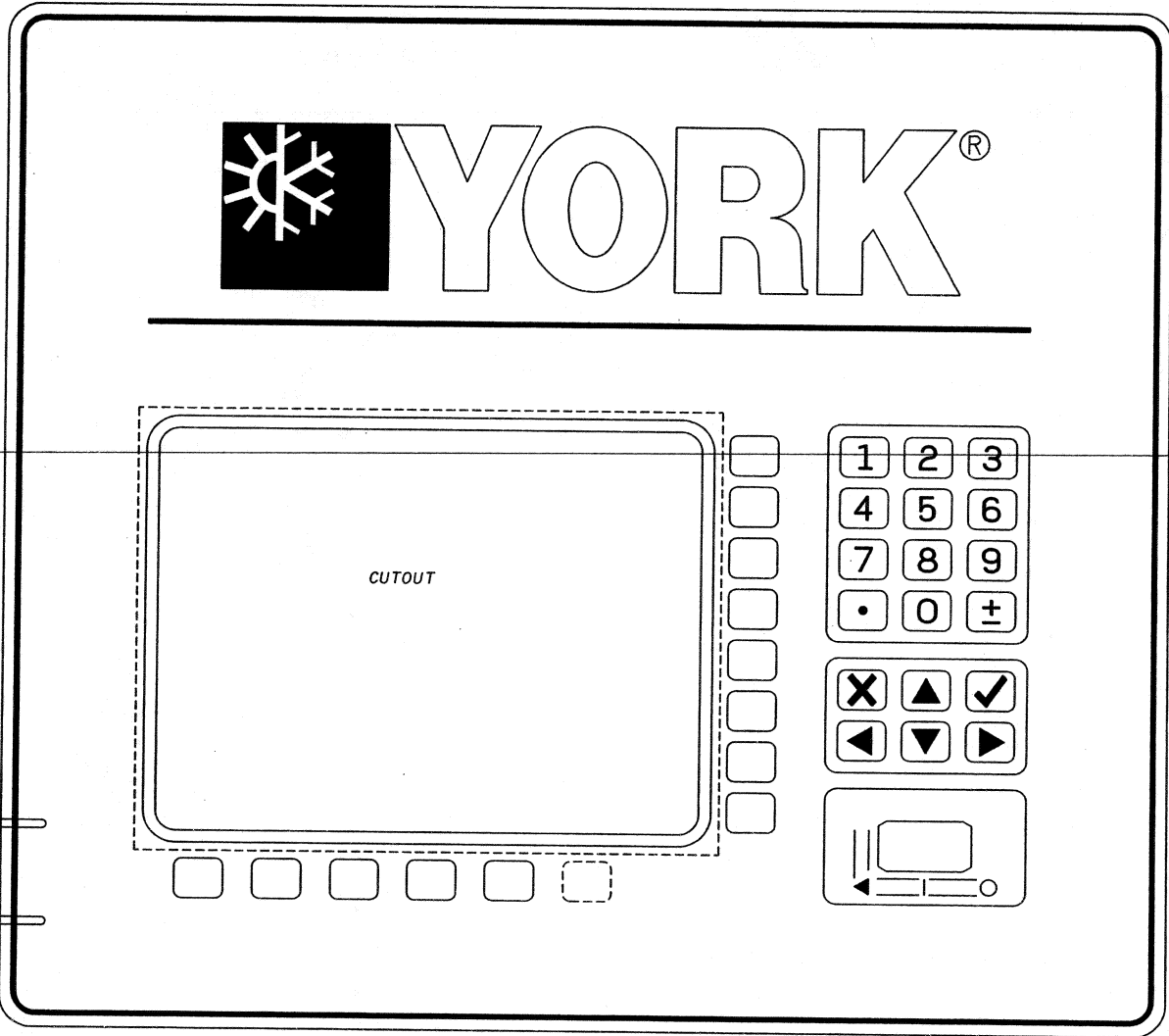

CONNECTOR

LD04074

FIG. 32 - KEYPAD

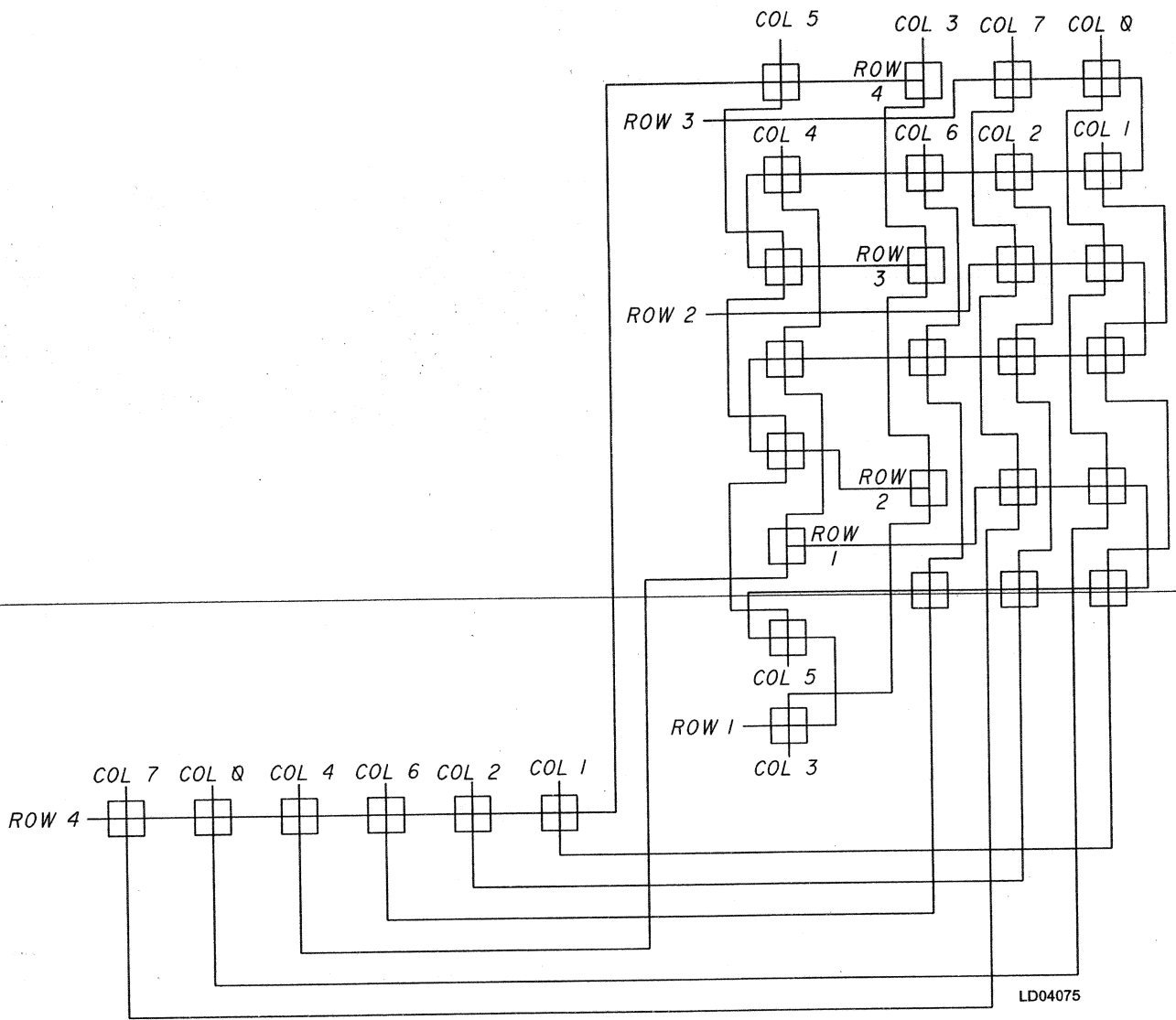

8

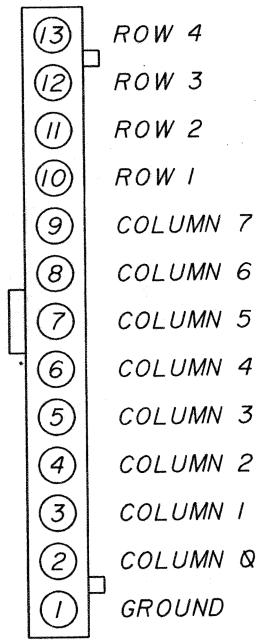

CONNECTOR PIN OUT

LD04076

FIG. 33 - KEYPAD

SECTION 9

POWER SUPPLY

(REFER TO FIG 34 & 35)

The Power Supply provides the DC power for the LCD Display and all the printed circuit boards in the Control Center. It receives a 102 to 132VAC input from an external power source and provides the following DC outputs:

- -12VDC
- +12VDC
- +5VDC
- +24VDC
- Ground

The +24VDC output provides power to the CM-2 Board (Electro-Mechanical starter applications), Solid State Starter Logic Board (Mod "A" SSS), Solid State Starter Logic/Trigger Board (Mod "B" SSS) or Adaptive Capacity Control (ACC) (Variable Speed Drive applications).

The -12VDC, +12VDC, Gnd and +5VDC outputs are applied to the Microboard. There, these voltages are applied to the circuits requiring the respective voltage. From the Microboard, the +12VDC and +5VDC are distributed to other system components requiring these voltages. These include the GPIC, I/O Board, LCD Display and Display Backlight Inverter Board.

As shown in Fig. 9, the Microboard contains two voltage regulators that create separate +5VDC and +3.3VDC supplies. The +5VDC supply is dedicated to all the Microboard Analog circuits and is labeled as the +5VDC (Analog) supply. It is also routed to all Pressure Transducers, Temperature Thermistors and Motor

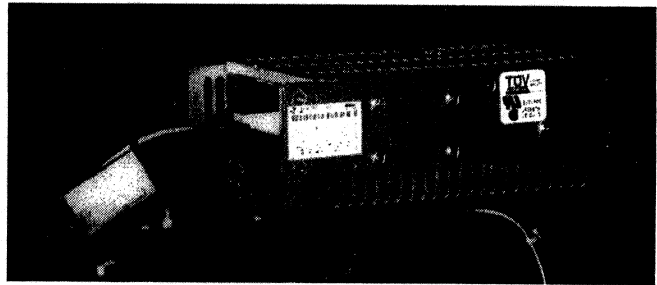
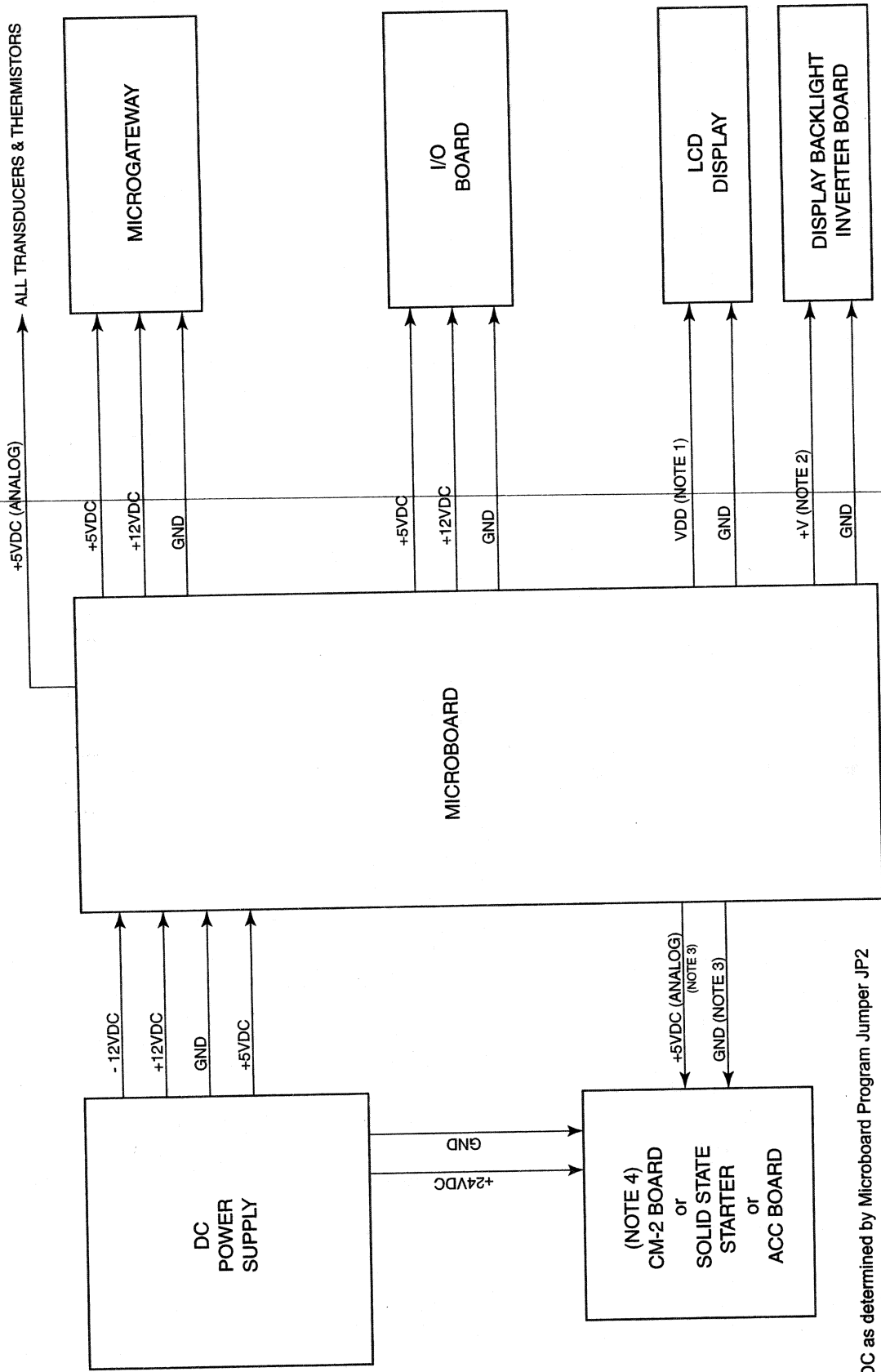

FIG. 34 – POWER SUPPLY

29136A

controller Board (CM-2, Solid State Starter Logic Board [Mod "A" SSS] or VSD ACC Board). This permits all Analog circuits to be powered by the same supply, eliminating any offsets caused by voltage regulator drift. The +3.3VDC supply is utilized by the Microprocessor, Flash Memory Card and other digital circuits. It could also be applied to the Backlight Inverter Board, depending on the Display manufacturer's requirements as explained below.

Different Display manufacturers can require different supply voltages for their display and supporting circuits. To accommodate the different Display manufacturer's voltage requirements, Microboard Program Jumpers JP2 and JP5 must be positioned to provide the required supply voltages to the Display and the Display Backlight Inverter Board. Either +5VDC or +3.3VDC, as determined by JP2, is applied to the Display. Either +12VDC or +5VDC, as determined by JP5, is applied to the Display Backlight Inverter Board. Refer to Table 1 "Microboard Program Jumpers".



LD06524

NOTES:

1. +5 or +3.3VDC as determined by Microboard Program Jumper JP2 & display requirements.
2. +12 or +5VDC as determined by Microboard Program Jumper JP5 & display requirements.
3. Not Applicable to VSD or Mod "B" Solid State Starter Applications.
4. Applications - CM2 (Em Starter), Logic Board (Mod "A" Solid State Starter), Logic/Trigger Board (Mod "B" Solid State Starter), Adaptive Capacity Control (VSD).

FIG. 35 – POWER SUPPLY – DC POWER DISTRIBUTION (REFER TO CONTROL CENTER WIRING DIAGRAM FOR WIRE CONNECTIONS)

SECTION 10

CURRENT MODULE (CM-2)

(REFER TO FIG 36 - 38)

On applications where the Compressor Motor is controlled by an Electro-Mechanical Starter, the Control Center is equipped with a **Current Module**. The Current Module provides compressor motor **Overload** and **Power Fault** protection. The Current Module also provides an analog voltage representing the compressor motor current to the Microboard for display and **Current Limit** control. While the chiller is running, the Microboard controls the Pre-rotation Vane (PRV) position to limit the motor current to the system 100% Full Load Amp (FLA) value.

The contacts of Current Module K1 relay (identified as "CM" contacts on the Control Center wiring diagram) are interfaced into the Motor Controller initiated shutdown circuit that is located between Control Center TB6-53 and I/O Board TB1-16 (ref. Fig 17 and 37). They are also connected as a digital input to I/O Board J2-1. Relay K1 is normally energized, maintaining its contacts in a closed position. Whenever the Current Module initiates a chiller shutdown, it de-energizes K1, opening its contacts. This interrupts the circuit to I/O Expansion Board RUN relay coil 1R (K18), de-energizing it and causing the Starter to shutdown. Simultaneously, the Microboard reads the opening of these contacts via I/O Board J2-1, initiates a **SYSTEM COASTDOWN** and displays the appropriate message as described below.

Three **Current Transformers** in the Compressor Motor Terminal Box (ref. Fig. 38) provide 3-phase motor current signals to the **Diode Bridge (DB)**. The required turns ratio of the Current Transformers is determined by the system 100% FLA. The Diode Bridge rectifies and combines the three signals into one DC signal that is applied to the parallel **Variable Resistors (RES)**. These are Factory adjusted (field adjusted on service replacements) to provide a nominal 1.0VDC (0.15 to 1.10VDC) signal to the Current Module at J1-1 and J1-2 when the compressor motor current is at 100% FLA. Fig. 38 contains a formula to calculate the resistance of RES required to achieve 1.0VDC at 100% FLA. The 100% FLA value is located on a label adhered to the inside of the Control Center door.

The motor current signal input at J1-1 & J1-2 is applied to potentiometer R8. This is Factory adjusted (field adjusted on service replacements) to illuminate the 105% CURR indicator (CR6) when the compressor motor current reaches 105% FLA. This calibrated voltage is applied to the **Power Fault** detector, **Overload** detectors and Multiplexer (MUX).

The **Power Fault** circuit protects the compressor motor and driveline from transient torque damage. It anticipates the transient torque condition by detecting a momentary interruption in motor current and de-energizing the starter before damage can occur. If the chiller has been running for >75 seconds and the motor current decreases to $\leq 10\%$ FLA, a **Power Fault** shutdown is initiated. The **Power Fault** indicator (CR5) is illuminated and remains illuminated until manually reset with **RESET** switch S2. Relay K1 is de-energized for 1 second and then returned to the energized state. Relay K1 contacts (CM) open for 1 second and then return to the closed state. A **SYSTEM COASTDOWN** is initiated and **POWER FAULT** is displayed on the Display. The chiller will automatically restart upon completion of **SYSTEM COASTDOWN**.

If the motor current remains continuously at $\geq 105\%$ FLA for 50 seconds (Nominal), an **OVERLOAD** shutdown is initiated. The **Overload** indicator (CR4) is illuminated and remains illuminated until manually reset with **RESET** switch S2. Relay K1 is de-energized, opening K1 contacts (CM). Relay K1 remains de-energized until manually reset with **RESET** switch S2. A **SYSTEM COASTDOWN** is initiated and **MOTOR CONTROLLER-CONTACTS OPEN** is displayed. The chiller cannot be started until **RESET** switch S2 is manually pressed.

If the motor current remains continuously at 245% FLA for 40 seconds, 290% FLA for 20 seconds or 360% FLA for 10 seconds, an **OVERLOAD** shutdown is initiated. Relay K1 and **Overload** indicator CR4 operate as described immediately above. A **SYSTEM COASTDOWN** is initiated and **MOTOR CONTROLLER - CONTACTS OPEN** is displayed. The

chiller cannot be restarted until **RESET** switch is manually pressed. **LRA/FLA** Potentiometer R16 is factory adjusted (field adjusted on service replacements) to the ratio of Locked Rotor Amps to Full Load Amps. The correct setting is determined by dividing the LRA by the FLA. If Switch S1 is in the "Y-Delta/57%" position, there is no 245% FLA threshold. Switch S1 must be positioned according to the type of Electro-Mechanical starter present; **UP** for Y-delta or Autotransformer starters, **DOWN** for Across-the-Line starters.

The Multiplexer (MUX) is an electronic switch with 8 inputs and 1 output. The address applied to it determines the position of the switch (i.e., which input is routed to the output). The inputs to channel 0 through 6 are grounded (0VDC). The input to channel 7 is a 0 to 4.0VDC analog signal, representing motor current over the range of 0 to 100% FLA. It is Factory calibrated by Potentiometer R34 to be 4.0VDC when the compressor motor current is at 100% FLA. Under Program control, the Microboard commands the MUX to route the inputs to the MUX output by applying 3-bit Binary addresses to the MUX address inputs at J5-1,2,3. The voltage level for a logic 1 is +12VDC and logic 0 is 0VDC. The Microboard reads the MUX outputs at J5-6. It first addresses channel 0 to determine the type of starter applied. The 0VDC at channel 0 indicates to the Microboard that this is an Electro-Mechanical Starter application (In all starter applications, the Micro reads channel 0 to determine the type starter applied; 0VDC = EM starter, >0VDC=Solid State Starter). It then addresses channel 7 (ignoring channels 1 through 6) to read the analog motor current voltage. The Microboard interprets this analog value in terms of %FLA and displays it upon operator keypad request. It also uses this value to invoke compressor motor **Current Limit** at 100% FLA and 104% FLA. When motor current rises to 100% FLA, the Microboard prevents any further current rise by inhibiting further Pre-rotation Vanes

(PRV) opening until it decreases to 98% FLA. If the motor current continues to rise to 104% FLA, the Microboard applies a close signal to the PRV until the motor current decreases to 102% FLA. While **Current Limit** is in effect, "**MOTOR - HIGH CURRENT LIMIT**" is displayed.

As detailed in the "System Calibration" section of this book, to field calibrate Potentiometer R8, the PRV must be manually operated to achieve 105% FLA compressor motor current. Therefore, during this procedure, **Current Limit** is not invoked until 107% FLA and 110% FLA. The first time the **PRV OPEN** key is pressed on the **COMPRESSOR** Screen after logging in at **SERVICE** access level, a 10 minute window is opened, allowing the current to rise to 107% FLA before further PRV opening is inhibited. This inhibit is released when the current decreases to 106% FLA. If the current continues to rise to 110%, manual control is overridden and a close signal is applied to the PRV until the current decreases to 109% FLA. After 10 minutes, the normal current limit thresholds of 100% FLA and 104% FLA are applied.

The MUX address inputs along with respective outputs are as follows:

BINARY			DECIMAL	OUTPUT
J5-1	J5-2	J5-3		
0	0	0	0	Ground
0	0	1	1	Ground
0	1	0	2	Ground
0	1	1	3	Ground
1	0	0	4	Ground
1	0	1	5	Ground
1	1	0	6	Ground
1	1	1	7	0-5.0VDC motor current analog signal calibrated on CM-2 board to be +4.0VDC at 100% FLA.

10

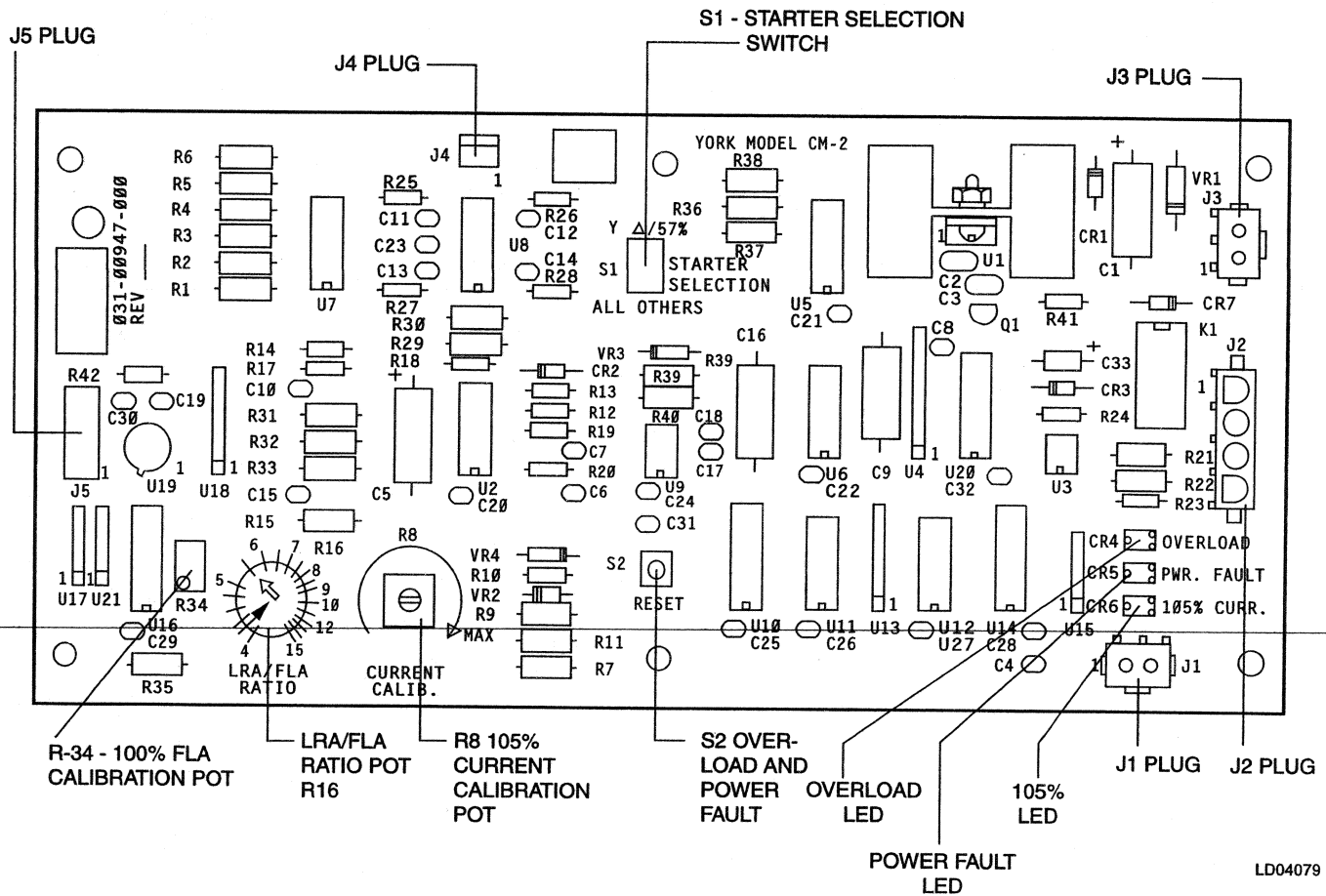

LD04079

FIG. 36 - CM-2 CURRENT MODULE (ELECTRO-MECHANICAL STARTER APPLICATION)

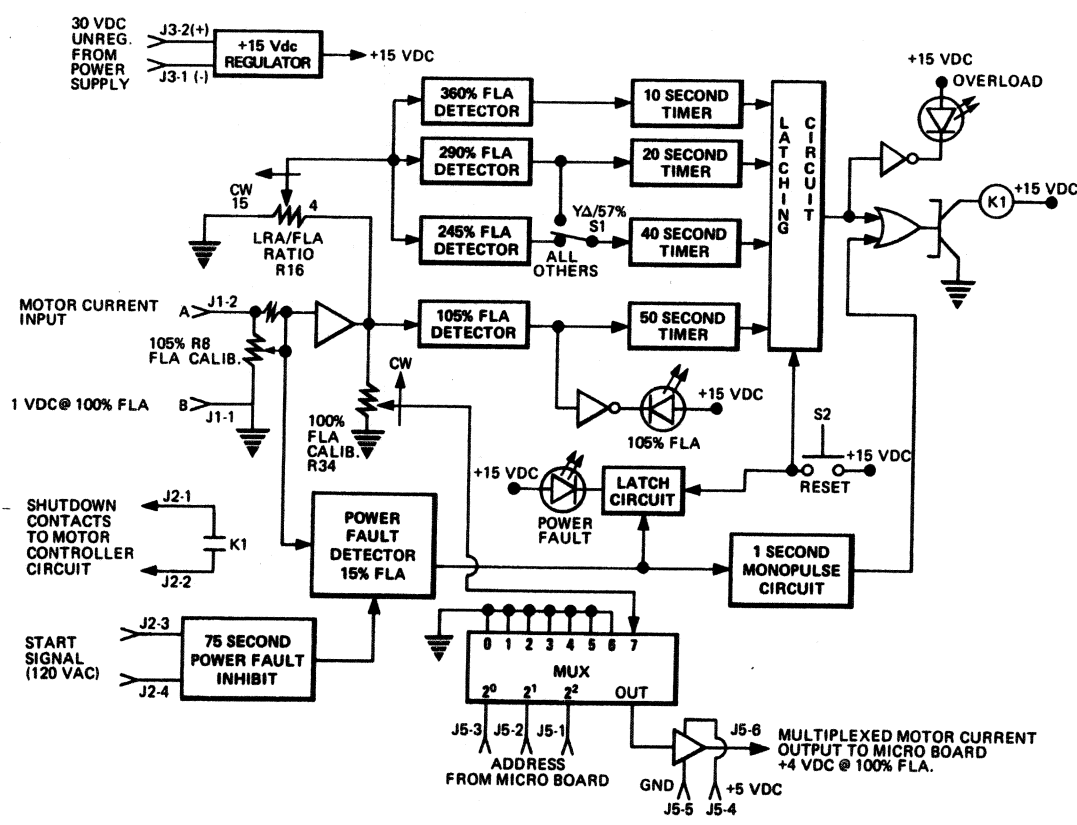

LD04080

FIG. 37 - CM-2 CURRENT MODULE (ELECTRO-MECHANICAL STARTER APPLICATIONS)

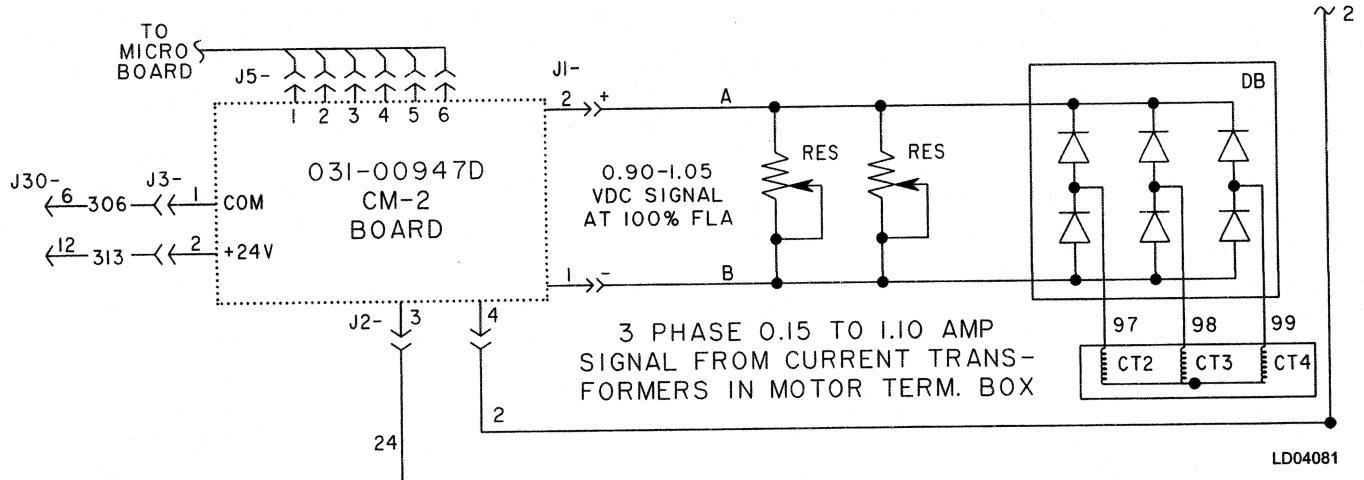

LD04081

MOTOR VOLTAGE	FLA	CT RATIO	RES ^D (OHMS)
208-600	65-111 ^A	200:1	R = 1.282 (CT RATIO) FLA
	112-224 ^A	350:1	
	225-829 ^A	700:1	
	830-1790 ^A	1400:1	
2300-4160	11-18 ^C	200:1	R = 0.247 (CT RATIO) FLA
	19-37 ^B	200:1	R = 0.370 (CT RATIO) FLA
	38-123 ^A	200:1	R = 0.740 (CT RATIO) FLA
	124-264 ^A	350:1	
	265-518 ^A	700:1	

NOTES:

- A. Requires passing motor lead through current transformer (CT) **once** before connecting to power supply.
- B. Requires passing motor lead through CT **twice** before connecting to power supply.
- C. Requires passing motor lead through CT **three** times before connecting to power supply.
- D. Calculates resistance of "RES" to achieve 1.0VDC at FLA.

10

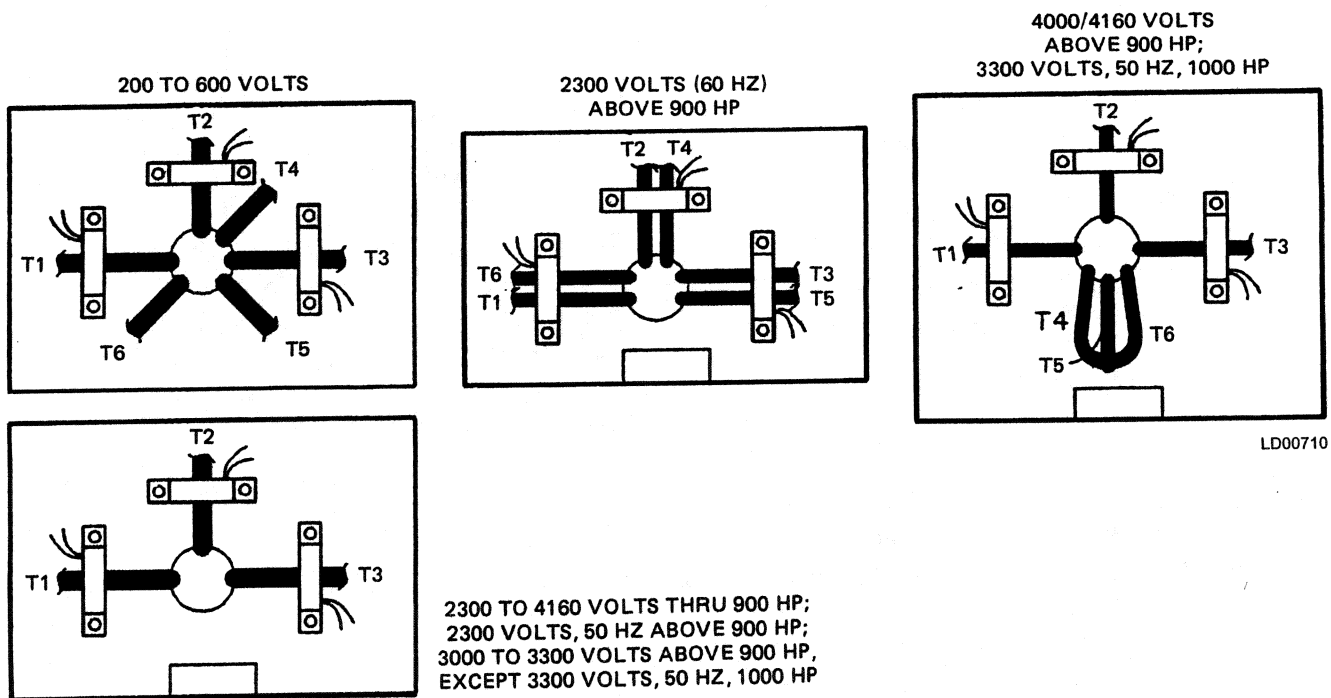

LD00710

FIG. 38 – CM-2 CURRENT MODULE – INTERFACE, CURRENT TRANSFORMERS & VARIABLE RESISTORS

SECTION 11

SOLID STATE STARTERS

(REFER TO FIGS. 39 - 42)

SOLID STATE STARTERS

The Control Center will accommodate either of two different YORK Liquid Cooled Solid State Starters (LCSSS). New production chillers after August 1999, are equipped with the Mod "B" LCSSS. This style LCSSS contains the Silicon Controlled Rectifier (SCR) assemblies, an integrated Logic/Trigger Board and interfaces the Control Center via a serial data communications link and hardwired relay contacts. The Control Center can be retrofit to earlier vintage chillers equipped with the previous version LCSSS that interfaces the Control Center via a multiplexed data interface and ~~hardwired relay contacts~~. This earlier vintage LCSSS houses the SCR assemblies and Trigger Board; a separate Logic Board is located inside the Control Center. Microboard Program Jumper JP39 must be positioned to invoke the appropriate Microboard/Program operation for the starter applied (refer to Table 1).

Mod "B" Serial Interface LCSSS (Refer to Fig. 39)

A complete description, theory of operation and troubleshooting instructions of this LCSSS are contained in YORK Service Manual 160.00-02. The following describes the interface and interaction of the LCSSS with the Control Center.

As shown in Figure 39, the LCSSS contains a single Logic/Trigger printed circuit board. This board performs the following functions:

- Generates the SCR trigger pulses
- Receives start/stop commands from the Microboard
- Transmits status and fault data to the Microboard
- Generates all LCSSS initiated Safety and Cycling shutdowns.

The Logic/Trigger Board is powered by +24VDC from the Control Center Power Supply. The Control Center Microboard (J15) communicates with this board via a 1200 baud 0/+5VDC serial data communications link. If this communications link does not operate properly, correct Microboard J15 serial port operation can be verified using the Serial Inputs and Outputs diagnostic procedure in the "Diagnostics and Troubleshooting" section of this book. The **STOP** relay contacts

on the Logic/Trigger Board assure a positive shutdown on all LCSSS initiated shutdowns.

After power has been applied to the system, the Microboard will attempt to establish communications with the Logic/Trigger Board. If unsuccessful within 10 attempts, the Microboard initiates a Cycling shutdown and displays "**LCSSS INITIALIZATION FAILED**" on the System Details line of the Control Center display. The Microboard will continue to establish communications until successful. Also, at power-up, the Logic/Trigger Board reads wire jumpers in its connector J1 to determine the LCSSS model applied (refer to 160.00-02). If an invalid jumper configuration is read, the Logic/trigger Board initiates a Cycling shutdown and "**LCSSS - INVALID CURRENT SCALE SELECTION**" is displayed on the System Details line of the Control Center Display. The model designation is transmitted to the Microboard for display on the **MOTOR** Screen. This designation determines the allowable range for the Full Load Amps (FLA) Setpoint and Start Current Setpoint. There are 4 LCSSS models: 7L, 14L, 26L and 33L. Each model has an allowable Full Load Amps (FLA) range and Start Current range as listed below.

Communications between the Microboard and Logic/Trigger Board are in the form of master/slave. The Microboard is the master and the Logic/Trigger Board is the slave. The Logic/Trigger Board sends two types of data to the Microboard: Status data and Fault data. After successful initialization, the Microboard sends a data request every 2 seconds. Normally, the Logic/Trigger Board responds to each request. However, if the Microboard does not receive a response to 10 consecutive requests, the Microboard initiates a Cycling shutdown and displays "**LCSSS - SERIAL COMMUNICATIONS**" on the System Details line of the Control Center display. In addition, the Logic/Trigger Board will initiate the same Cycling shutdown if it does not receive a data request from the Microboard after 10 successive attempts to send data.

Anytime the Logic/Trigger Board initiates a Cycling or Safety shutdown, it opens its **STOP** contacts that are connected in series with the Control Center's 1R (K18) **RUN** relay coil. The contacts remain open as long as the condition exists. The open **STOP** contacts

interrupt the circuit to 1R causing it to de-energize, removing the run signal to the LCSSS. Simultaneously, the Microboard reads the opening of the LCSSS STOP contacts via the I/O Board J2- 1. This signals the Microboard that the LCSSS has initiated a shutdown. The Logic/Trigger Board sends the cause of the shutdown in response to the next data request. This is logged on the **HISTORY** Screen as the “**LAST FAULT WHILE RUNNING**”. A snapshot of the LCSSS operating parameters valid at the instant of the fault are also sent. Any additional faults that occur within the 2 second transmission time are also sent and logged on the **HISTORY** Screen under “**LAST TEN FAULTS**”. Refer to Operation Manual 160.55-O1 for description of all Cycling and Safety shutdown messages. While this data is being sent, “**LCSSS - SHUTDOWN - REQUESTING FAULT DATA**” is displayed on the System Details line of the Control Center display. If fault data is not returned within 2 seconds, the Microboard will continue to send a request at 2 second intervals until the fault data is returned. If none is returned within 10 consecutive requests, it assumes it is not forthcoming and it displays “**LCSSS - STOP CONTACTS OPEN**” on the System Details line of the display.

The chiller can be started if there are no Safety and Cycling conditions. If the temperature of any of the SCR modules are >110°F, the LCSSS cooling pump will run and the chiller will be inhibited from starting until the temperature has decreased below 109°F. While this start inhibit is in effect, “**LCSSS - HIGH TEMPERATURE PHASE X - STOPPED**” (where X is phase A, B, or C) is displayed on the System Details line of the display. When the chiller is started, the Control Center sends two start signals simultaneously to the Logic/Trigger Board. One is transmitted via the serial communications link. The other is the closure of 1R (K18) Start relay, applying 115VAC to Logic/Trigger Board TB1-24. If these two signals are not received within 5 seconds of one another, the Logic/Trigger Board initiates a cycling shutdown and “**LCSSS - RUN SIGNAL**” is displayed on the System Details line of the display.

The Logic/Trigger Board transmits the following parameters over the serial communications link for display on the **MOTOR** Screen:

- Three phase motor current
- Three phase line-to-line motor supply voltage
- Input Power (KW)

- Three phase SCR module temperature
- Starter model designation

The following are the programmable setpoints associated with the LCSSS. They are programmed on the **MOTOR** Screen. Refer to programming instructions in the “System Calibration, Service Setpoints and Reset Procedures” section of this book.

- **Full Load Amps** - This is the maximum allowed motor current at which this chiller is permitted to operate to achieve maximum design capacity. It is the Full Load Amps (FLA) of the chiller, as listed on the **SALES ORDER** Screen. Each starter model has a permissible range over which this setpoint can be programmed as follows:

LCSSS Model	Permissible FLA
7L-46, 58 and 50	35 to 260 Amps
14L-17, 28, 46, 58 and 50	65 to 510 Amps
26L-17, 28, 46, 58 and 50	125 to 850 Amps
33L-17, 28, 46 and 50	215 to 1050 Amps

- **Start Current** - The Logic/Trigger Board will limit inrush motor current to this value during starting. The programmed value is sent to the Logic/Trigger Board over the serial communications link. This setpoint should be programmed to (0.45 x motor Delta Locked Rotor Amps) as listed on the **SALES ORDER** Screen. Each model starter has a permissible range over which this setpoint can be programmed as follows:

LCSSS Model	Permissible Start Current Range
7L-46, 58 and 50	310 to 700 Amps
14L- 17, 28, 46, 58 and 50	620 to 1400 Amps
26L- 17, 28, 46, 58 and 50	1150 to 2600 Amps
33L-17, 28, 46 and 50	1460 to 3300 Amps

- **Supply Line Voltage Range** - This setpoint is the line voltage application and establishes the high and low line voltage shutdown thresholds. Shutdown and restart thresholds are contained in Operation manual 160.55-O1 under the messages “**LCSSS - LOW SUPPLY LINE VOLTAGE**” and “**LCSSS - HIGH SUPPLY LINE VOLTAGE**”.
- **Open SCR Enable/Disable** - This enables or disables the Open SCR detection Safety protection per-

formed by the Logic/Trigger Board. This protection must **never** be disabled unless advised by the YORK factory.

- **Kilowatt Hours (KWH) Reset** - This allows the accumulated KWH to be set to a desired starting value in the event the BRAM has to be field replaced. This must **never** be arbitrarily performed.

To assure the chiller is not permitted to run for extended periods with the supply line voltage outside of acceptable limits, the Logic/Trigger Board compares the actual 3-phase line voltage to the thresholds established with the Supply Line Voltage Range setpoint. Each supply voltage application has an allowable upper and lower limit. If the supply voltage goes above or below these limits continuously for 20 seconds, the logic trigger Board initiates a Cycling shutdown and displays "LCSSS - HIGH SUPPLY LINE VOLTAGE" or "LCSSS - LOW SUPPLY LINE VOLTAGE" as appropriate. The chiller will automatically restart when the line voltage is within the acceptable range.

While the chiller is running, the Microboard will close or inhibit opening of the Pre-rotation Vanes (PRV), as required, to limit the compressor motor current to the Current Limit or Pulldown Demand Limit setpoint (30% to 100% FLA) that is in effect. The Microboard calculates the "% Full Load Amps" (FLA) by dividing the highest phase of the 3-phase motor current, received from the Logic/Trigger Board, by the value programmed for the **FULL LOAD AMPS** setpoint. "% **FULL LOAD AMPS**" is displayed on the **MOTOR** Screen. If the motor current increases to the extent that the "% **FULL LOAD AMPS**" reaches 100% of the Current Limit Setpoint, the PRV are inhibited from further opening until the motor current decreases to $\leq 98\%$ of the Current Limit setpoint. If the motor current increases to the extent that the "% **FULL LOAD AMPS**" is 104% of the Current Limit setpoint, the PRV will be driven closed until the "% **FULL LOAD AMPS**" decreases to 102% of the Current Limit setpoint. The PRV opening will then be inhibited until the "% **FULL LOAD AMPS**" decreases to $\leq 98\%$ of the Current Limit setpoint.

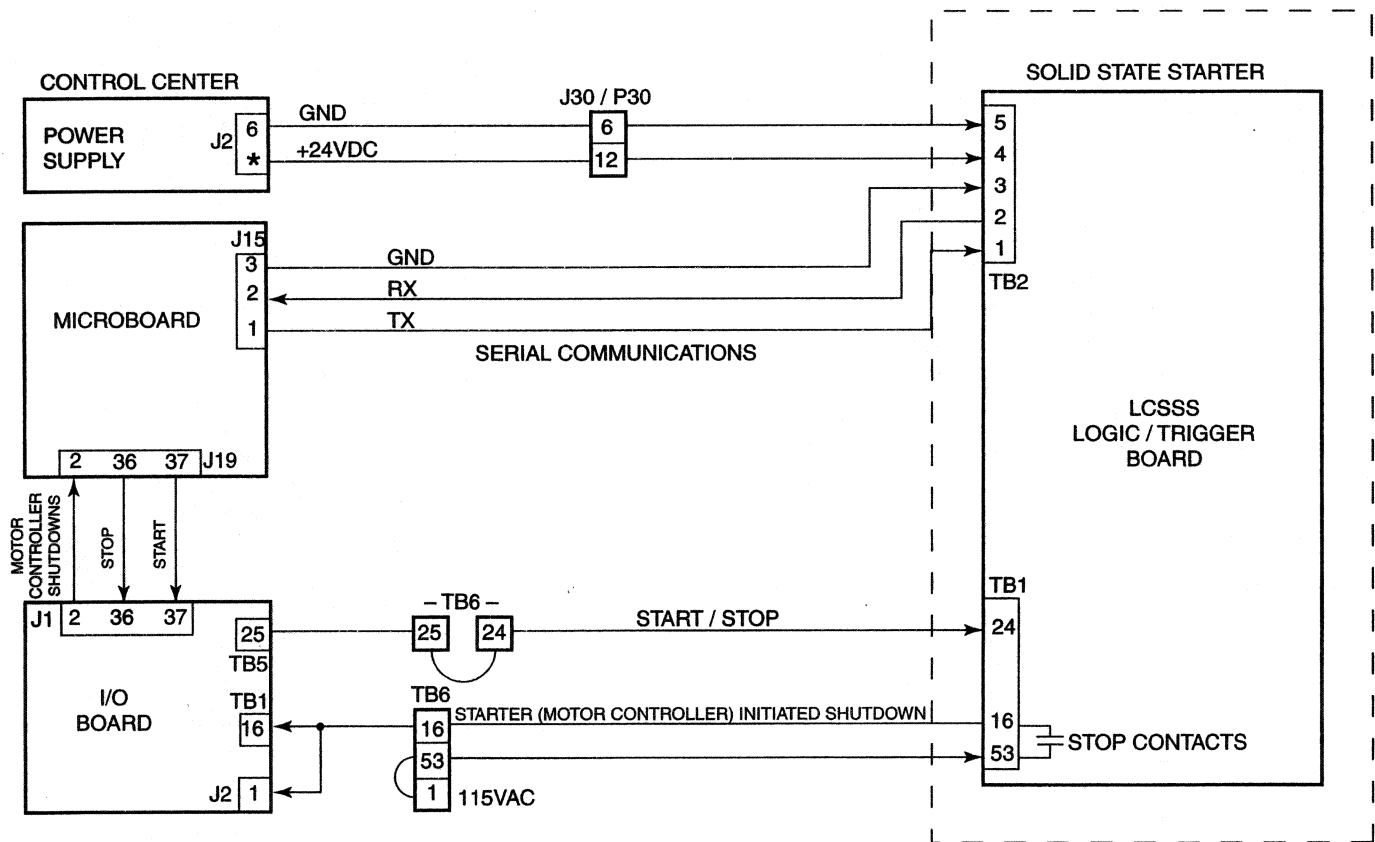

NOTES:

* 9 - "CONDOR" Power Supply; 13 - "POWER ONE" Power Supply

LD04648

FIG. 39 - MOD "B" LIQUID COOLED SOLID STATE STARTER (LCSSS) - INTERFACE

Mod "A" Multiplexed Data Interface LCSSS (Refer to Fig. 40, 41 & 42)

A complete description, theory of operation and troubleshooting instructions of this LCSSS are contained YORK Service Manual 160.46-OM3. 1.

As shown in Fig. 40, the Logic Board of this model starter is mounted inside the Control Center.

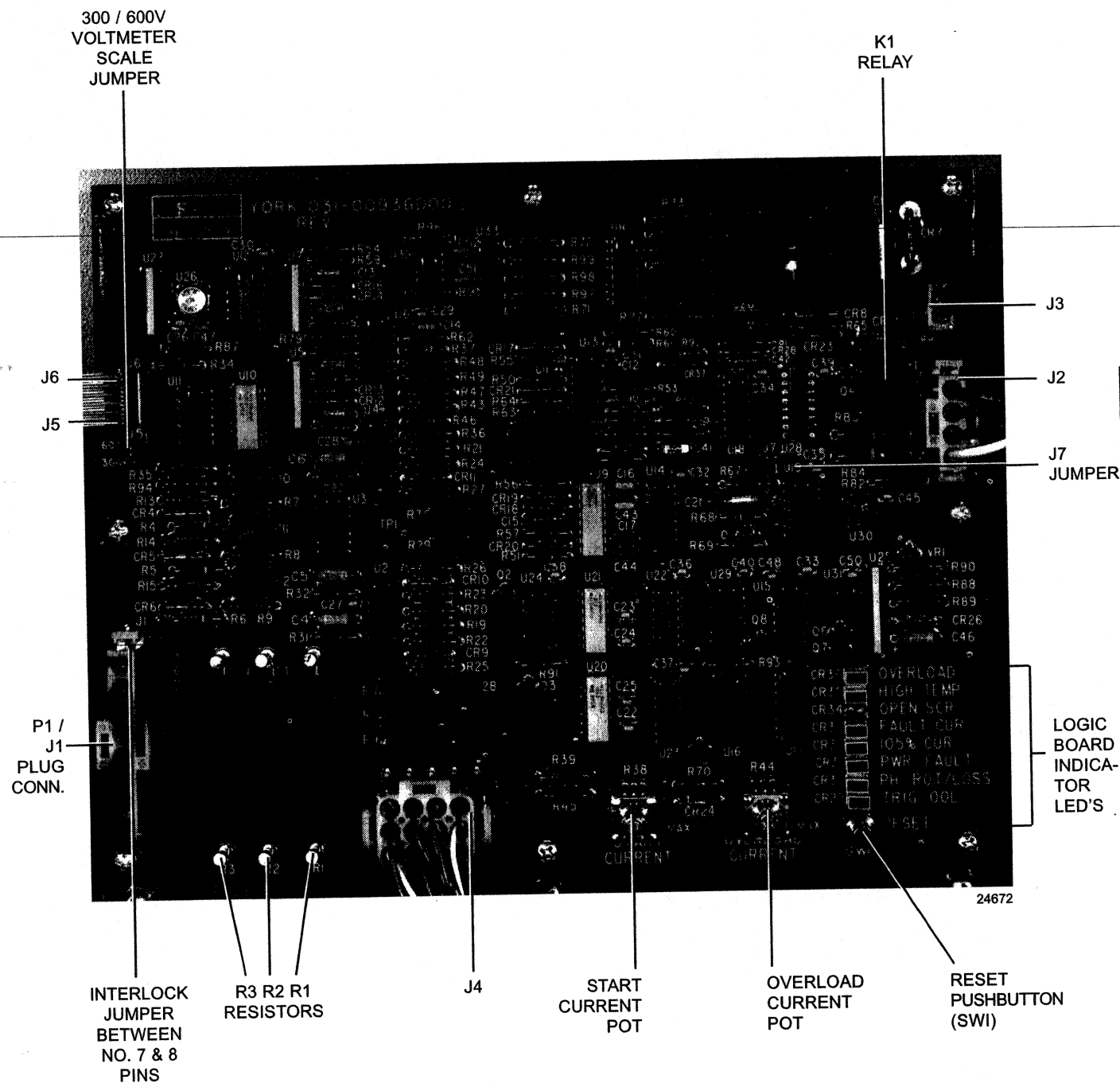

FIG. 40 – SOLID STATE STARTER LOGIC BOARD

This board provides **Overload, Power Fault, Fault Current, Phase Rotation/Loss, and Half Phase Protection** for the Compressor Motor. It also receives SCR High Temp and Trigger Out Of Lock (OOL) shutdown signals from the Starter Trigger Board. Finally, it provides analog voltages representing Compressor Motor Current, Power Line Voltage, Current Limit commands and a Starter Model code to the Microboard.

The contacts of Logic Board relay K1 (identified as "CM" contacts on the Control Center wiring diagram) are interfaced into the Motor Controller initiated shutdown circuit that is located between Control Center TB6-53 and I/O Board TB1-16 (ref. Fig. 16 and 37). They are also connected as a digital input to I/O Board J2-1. Relay K1 is normally energized, maintaining its contacts in a closed position. Whenever the Logic Board initiates a chiller shutdown, it de-energizes K1, opening its contacts. This interrupts the circuit to I/O Board RUN relay coil 1R (K18), de-energizing it and causing the Starter to de-energize. Simultaneously, the Microboard reads the opening of these contacts via I/O Board J2-1, initiates a **SYSTEM COASTDOWN** and displays the appropriate message as described below.

When the Logic Board detects an **Overload** condition, Relay K1 contacts open and the **Overload LED** illuminates. "**MOTOR CONTROLLER – CONTACTS OPEN**" is displayed. The contacts remain open and the LED remains illuminated until manually reset with the Logic Board's S1 **RESET** switch. After S1 is pressed, the chiller can be restarted.

When a **Power Fault, Fault Current** or **Half Phase** condition is detected, Relay K1 contacts open for 1 second and then close. The **Power Fault LED** illuminates and will remain illuminated until manually reset with the S1 **RESET** switch. **POWER FAULT** is displayed. At the completion of **SYSTEM COASTDOWN**, the chiller will automatically restart.

When a Power line Phase Rotation/Loss or Trigger Board Out of Lock (OOL) condition is detected, Relay K1 contacts open and remain open for as long as the condition exists. If the contacts remain open for more than 3 seconds, **MOTOR CONTROLLER – CONTACTS OPEN** is displayed; if less than 3 seconds, **POWER FAULT** is displayed. The respective Ph. Rot/

Loss or Trig. OOL LED illuminates and remains illuminated until manually reset with the S1 **RESET** switch. The chiller will automatically restart when the contacts close.

The Starter Trigger Board monitors the Starter's Silicon Controlled Rectifier (SCR) heatsink temperature. Whenever the heatsink temperature increases to 212°F, the Trigger Board signals the Logic Board. **MOTOR CONTROLLER – CONTACTS OPEN** is displayed. The Logic Board illuminates the **High Temp LED** and opens Relay K1 contacts. The LED remains illuminated and the contacts remain open until the temperature decreases to less than 110°F and manually reset with the Logic Board's S1 **RESET** switch. After S1 is pressed, the chiller can be restarted. In routine operation, each time the chiller is shutdown for any reason, it is prevented from restarting until the heatsink temperature decreases to less than 110°F. While it is waiting for the temperature to decrease to this threshold, the **HIGH TEMP LED** is illuminated, Relay K1 contacts are open, and **MOTOR CONTROLLER – CONTACTS OPEN** is displayed. When the temperature is below 110° F, K1 contacts will open, the LED is extinguished, **MOTOR CONTROLLER – CONTACTS OPEN** message is cleared and the chiller will automatically restart.

The Multiplexer (MUX) is an electronic switch with 8 inputs and 1 output. The address applied to it determines the position of the switch and therefore the output. Under Program control, the Microboard sequentially addresses MUX channels 0 through 7. The voltage output of each channel is listed in the table below. Channel 0 is an analog voltage that represents the Starter model and Power Line voltage Voltmeter scale. The Program uses this value to limit the Full Load Amps Setpoint range to the maximum allowed value for the Starter size. This value also determines the Line Voltage display range and Motor current display range. Channel 1 is a current limit command that forces the Micro to perform Pre-rotation vanes inhibit and closure at the 100% and 104% FLA. This command is in addition to the Micro's software current limit feature that's based on a calculation comparing the highest current phase to the programmed Full Load Amp Setpoint to arrive at an FLA Percentage. Channels 2 though 4 are analog voltages representing Phase C, B and A

Power Line Voltages. Channels 5 through 7 are analog voltages representing Phase A, B and C Compressor Motor Current. The addresses are +12VDC for logic high (1). <1VDC for logic low (0).

The Logic Board MUX address inputs, along with the respective outputs are as follows:

BINARY			DECIMAL	OUTPUT
J6-1	J6-2	J6-3		
0	0	0	0	Starter Model/Voltmeter/Ammeter full scale, max FLA: 0.41 to 0.77VDC – 7L, 600VAC, max FLA 281, full scale 787A 0.78 to 1.22VDC – 14L, 300VAC, max FLA 551, full scale 1574A 1.23 to 1.76VDC – 14L, 600VAC, max FLA 551, full scale 1574A 1.77 to 2.39VDC – 26L, 300VAC, max FLA 916, full scale 2938A 2.40 to 3.08VDC – 26L, 600VAC, max FLA 916, full scale 2938A 3.09 to 3.87VDC – 33L, 300VAC, max FLA 1134, full scale 3672A 3.88 to 5.00VDC – 33L, 600VAC, max FLA 1134, full scale 3672A
0	0	1	1	Current Limit commands 3.46 to 5.00VDC - <98% FLA 1.21 to 3.45VDC - ≥100% FLA 0.0 to 1.20VDC - ≥104% FLA
0	1	0	2	Phase "C" AC Power Line voltage as follows: $300\text{VAC scale} = \text{VDC}(\text{out}) = \frac{\text{VAC}}{67.9}$ $600\text{VAC scale} = \text{VDC}(\text{out}) = \frac{\text{VAC}}{135.8}$
0	1	1	3	Phase "B" AC Power Line voltage. Same as Phase "C" above.
1	0	0	4	Phase "A" AC Power Line voltage Same as Phase "C" above.
1	0	1	5	Phase "A" Compressor Motor Current. 0 to +5VDC spanning range in address 0 above.
1	1	0	6	Phase "B" Compressor Motor Current. 0 to +5VDC spanning range in address 0 above.
1	1	1	7	Phase "C" Compressor Motor Current. 0 to +5VDC spanning range in address 0 above.

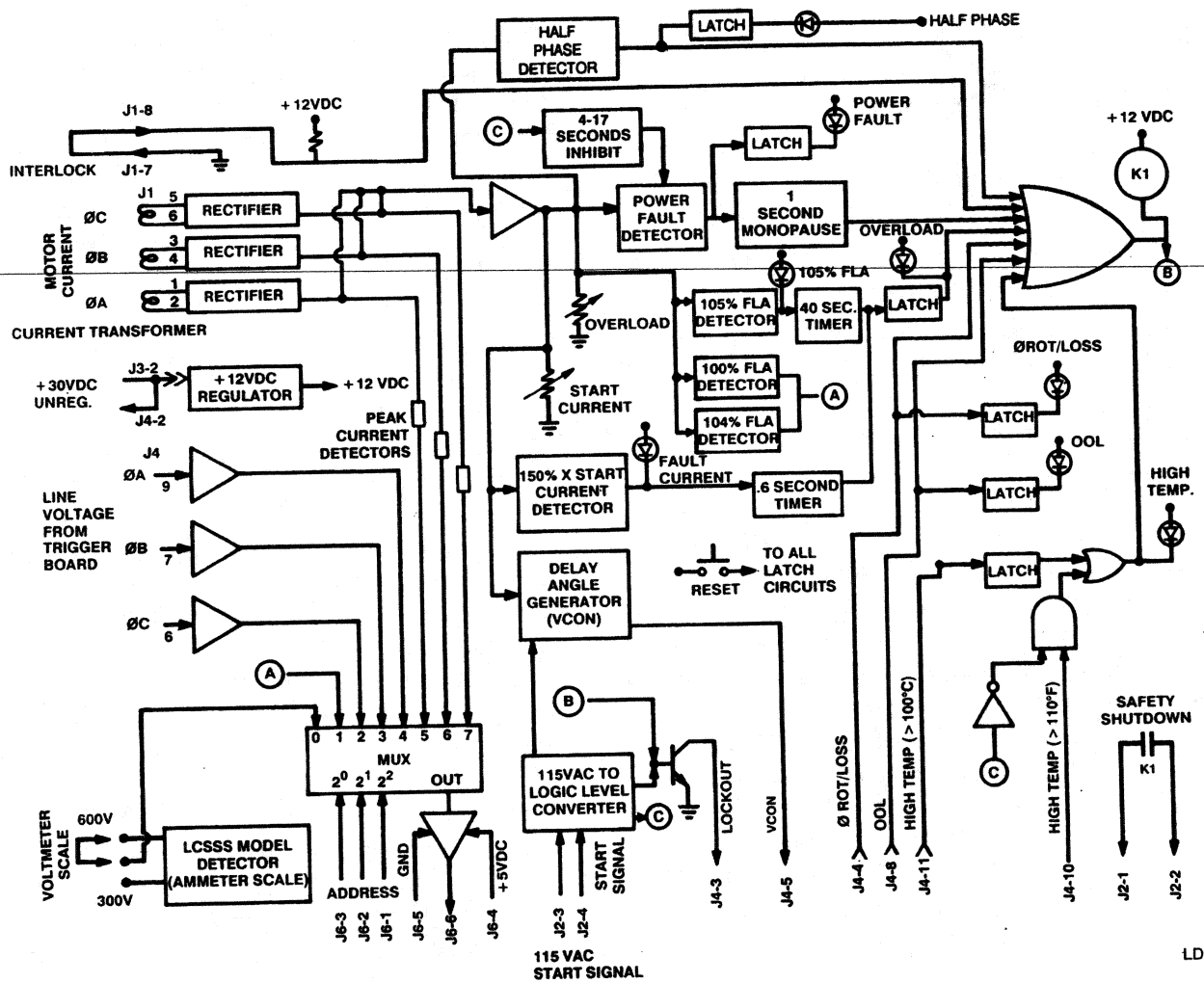

11

FIG. 42 - MOD A SOLID STATE STARTER LOGIC BOARD

SECTION 12

ADAPTIVE CAPACITY CONTROL BOARD

(REFER TO FIG. 43 - 45)

On applications where the compressor motor is driven by the YORK Variable Speed Drive (VSD), the Control center is equipped with an **Adaptive Capacity Control (ACC) Board** (Fig. 43). This board performs the following functions:

- Acts as a bidirectional serial communications gateway between the Microboard and the **VSD Logic Board** and **VSD Harmonic Filter Logic Board**.
- Tells the VSD Logic Board at what speed (frequency) to operate the compressor motor. The speed will be the lowest speed between 30 to 60(50)Hz it can operate without compressor surging.
- Detects Compressor surge conditions.
- Creates a **Surge Map** in battery backed memory by storing the Pre-rotation Vanes (PRV) position, motor speed (frequency) and Evaporator/Condenser pressure differential (head) that exists when each surge occurs.

The VSD consists of a power electronics section, Logic Board and an optional Harmonic Filter with Harmonic Filter Logic Board, all mounted in a cabinet that is either mounted to the compressor motor or floor standing (retrofit applications). The ACC Board is mounted inside the Control Center. In operation, the VSD Logic Board a.) controls the VSD power electronics to drive the compressor motor at the speed designated by the ACC Board, b.) monitors power electronics parameters and initiates chiller shutdowns when safety thresholds are exceeded and c.) transmits the parameters to the ACC Board for transfer to the Microboard for display. The optional Harmonic Filter reduces the power line harmonics produced by the VSD. The Harmonic Filter Logic Board a.) controls the filter b.) monitors filter parameters and initiates chiller shutdowns when safety thresholds are exceeded and c.) transmits these parameters to the ACC Board for transfer to the Microboard for display. Complete operation and service details of the VSD and ACC Board is contained in YORK manual 160.00-M1.

The Microboard communicates with the ACC Board, VSD Logic Board and the optional Harmonic Filter Logic Board via 0/+5VDC 1200 baud serial communications (Fig. 44). The ACC Board is the center point of

communications between the Microboard and the VSD components. The communications is in master/slave form. The VSD Logic Board and Harmonic Filter Logic Boards act as slaves to the ACC and the ACC acts as a slave to the Microboard. The Microboard initiates all communications by sending a command to the ACC Board. The ACC Board passes the command to the VSD Logic Board. The VSD Logic Board responds to the command by returning the requested data to the ACC Board and passes the command to the Harmonic Filter logic Board. The Harmonic Filter Logic Board returns the requested data to the ACC Board. The ACC Board returns both the VSD Logic Board's response and the Harmonic Filter's response to the Microboard.

There are three different commands issued from the Microboard: **Test and Initialize**, **Fault Data Request** and **Status Data Request**. When power is first applied to the Control Center, the Microboard establishes serial communications with the ACC, VSD Logic and Harmonic Filter Logic Boards. To establish communications, it sends a Test and Initialize command to the ACC Board, which sends the command on to the VSD Logic Board. The VSD Logic Board relays the command to the Harmonic Filter Logic Board. If the VSD Logic and Harmonic Filter Boards respond appropriately to the ACC Board, the ACC Board responds to the Microboard and communications are established. If any of these boards fail to respond to the first command, the Microboard sends the command again 4 seconds later. It will continue to send this command at 4 second intervals until a response is received. If, after 10 attempts, no response is received, a Cycling shutdown is performed and **VSD -INITIALIZATION FAULT** is displayed. The Microboard will continue to establish communications until successful. Anytime communications have been established and then lost, the Microboard will repeat this process to reestablish communications.

After communications have been established, the Microboard sends a Fault Data Request command. If there have been any faults detected by the VSD Logic or Harmonic Filter Boards since communications were lost, they are returned to the Microboard at this time. If there is no response within 2 seconds, this command is sent at 2 second intervals until a response is received.

If no response is received in 10 attempts, a Cycling shutdown is performed and **VSD – SERIAL COMMUNICATIONS** is displayed.

The Microboard then begins normal communications with the ACC, VSD Logic and Harmonic Filter Boards. During normal communications, commands and data are exchanged every 2 seconds on the serial communications link. The Microboard sends a Status Data Request command every 2 seconds to the ACC Board which is passed along to the VSD Logic Board and Harmonic Filter Logic Boards as described above. It expects to receive the data listed below in response each of these commands. If a response is not received to 10 consecutive commands, a Cycling shutdown is performed and **VSD – SERIAL COMMUNICATIONS** is displayed. The VSD Logic and Harmonic Filter Boards send the data listed below to the ACC Board and the ACC Board adds its data to it and returns all the data to the Microboard in one response. This continues until the VSD Logic or Harmonic Filter Boards detect a fault condition.

As stated above, if communications are lost with the VSD Logic Board, a Cycling shutdown is performed and **VSD – SERIAL COMMUNICATIONS** is displayed. However, if communications are lost with the Harmonic Filter Logic Board, no shutdown is performed, only **WARNING – HARMONIC FILTER – DATA LOSS** is displayed.

When a VSD fault condition is detected, the VSD Logic Board opens its VSD Stop Contacts that are connected in series with the Control Center's 1R (K18) RUN RELAY coil. This interrupts the circuit to 1R causing it to de-energize, removing the run signal to the VSD. Simultaneously, the Microboard reads the opening of the VSD Stop Contacts via its interface to the Control Center's I/O Board input J2-1. This notifies the Microboard that a VSD shutdown has occurred. The Microboard requests the cause of the shutdown by sending a Fault Data Request command. While this request is being processed, the Microboard displays **VSD SHUTDOWN – REQUESTING FAULT DATA**. When the cause of the shutdown is received, the Microboard displays a message describing the shutdown (refer to YORK Operation Manual 160.55-O1 for complete listing of messages) and begins sending normal Status Data Request commands. If the fault data is not returned to the Microboard within 2 seconds, it sends the command every 2 seconds until fault data is returned.

If none is returned within 10 requests, it assumes it is not forthcoming and displays **VSD – STOP CONTACTS OPEN**.

The following VSD status data is transmitted from the VSD Logic Board to the ACC Board for transfer to the Microboard for display:

- Output Frequency
- Output Voltage
- Output Current - three phase
- Input Power KW
- KWH
- 100% Job FLA
- DC Link Voltage
- DC Link Current
- Internal Ambient Temperature
- Inverter Heatsink Temperature – phase A, B, & C
- Converter Heatsink Temperature
- Pre-charge Relay energized/de-energized
- SCR Gate Drivers enabled/disabled
- Water (cooling) Pump on/off
- VSD running/stopped
- VSD Software version
- Motor HP

The following Harmonic Filter status data is transmitted from the Harmonic Filter Logic Board to the ACC Board for transfer to the Microboard for display:

- Input KVA
- Total Power Factor
- Filter DC Link Voltage
- Input voltage- phase A, B & C
- Input voltage THD – phase A, B & C
- Input Peak voltage – phase A, B & C
- Input Current – phase A, B & C
- Input current TDD – phase A, B & C
- Filter current – phase A, B & C
- Filter Heatsink temperature
- Filter Operation- running/stopped
- Filter Pre-charge relay – energized/de-energized
- Filter Supply Relay - energized/de-energized
- Input Phase Rotation – ABC/CBA
- Harmonic Filter – present/not present

The following ACC status data is transmitted from the ACC Board to the Microboard for display.

- Delta P/P (Head pressure)
- Pre-rotation Vanes position
- Surge count

The compressor motor speed can be controlled either manually in **MANUAL** mode or automatically in **AUTO** mode.

In **MANUAL** speed control mode, the speed can be controlled from the **VSD Tuning** Screen using Keypad keys. The speed can be set to a pre-selected frequency over the range of 10 to 60(50)Hz, Or, it can be increased or decreased over the range of 0.0 to 60(50)Hz in increments of 0.1 to 10Hz. Instructions for manual control are included in the "System Calibration, Service Setpoints and Reset Procedures" section of this book. Via Serial communications, the speed command is sent from the Microboard to the ACC Board, where it is passed on to the VSD Logic Board. The VSD Logic Board controls the VSD to operate the motor at this frequency. While Manual control is selected, **VALID POINT LED CR8** is illuminated, indicating that surges will not be mapped in the Surge Map. Anytime this LED is illuminated, surges are not mapped, as explained below. In making the transition from Manual to Auto mode, if the speed was manually set to <30Hz, it will automatically be set to 30Hz and automatically adjusted from this value. If not in Current Limit and the actual speed is <60(50)Hz, and 60(50)Hz is selected, the speed will be increased as follows. If the Leaving Chilled Liquid temperature is within 0.2°F, the PRV will simultaneously be driven closed per the following:

Speed Increase

- 0.2Hz every second if Leaving Chilled Liquid Temperature >0.2°F below the Setpoint and motor current is <80% FLA.
- 0.2Hz every 1 + (%FLA-80) second if Leaving Chilled Liquid Temperature is >0.2°F below the Setpoint and the motor current is >80% but < 98% FLA.
- 0.2Hz every 19 seconds if none of the above conditions are present.

PRV Close

A close signal of the following durations is applied every 4.5 seconds:

- 3.9 seconds if PRV position >50%.

- 3.0 seconds if PRV position >25% but <50%.
- 1.5 seconds if PRV position <25%.

In **AUTO** speed control mode, the ACC Board controls the speed. It determines the optimum compressor motor speed (frequency) over the range of 30 to 60(50)Hz and sends this value to the VSD Logic Board via the Serial communications link. The VSD logic Board controls the VSD to operate the motor at this frequency. The optimum speed is the slowest speed possible that will avoid compressor surge conditions but still allow the chiller to meet capacity requirements. This speed is found in an adaptive sense as explained below.

In determining the optimum motor speed, the ACC Board employs the following:

- **Delta P/P** – This is the chiller Head pressure. It is calculated as (Condenser pressure – Evaporator pressure) / Evaporator pressure. It ranges from 0.00 to 3.60. The ACC Board calculates this value from evaporator and condenser pressure values received from the Microboard via serial communications link. The ACC Board returns the calculated Delta P/P value to the Microboard for display over the same link.
- **Pre-rotation Vanes (PRV) position** – A potentiometer provides PRV position (0 to 100%) to the ACC Board. The position is 0% when fully closed, 100% when fully open. This value is sent to the Microboard via serial communications for display. The potentiometer must be calibrated by a qualified Service technician using a procedure in the "System Calibration, Service setpoints and Reset Procedures" section of this book. No speed reduction is permitted if this calibration has not been performed.
- **Motor Speed** – This is the actual drive frequency of 30 to 60(50) Hz.
- **Surge Map** – This contains the Delta P/P, PRV position and motor speed that existed at the instant of each previously encountered surge condition. These parameters are stored as a 3-dimensional array for each surge. The surge map is stored in the ACC Board's BRAM battery backed memory. The following procedures are detailed in the "System Calibration, Service Setpoints and Reset Procedures" section of this book: The entire Surge Map can be printed by pressing the **SURGE MAP PRINT** keypad key. Surge Map points can be automatically printed to an external printer as they are plotted. The Surge Map can be cleared.



The Surge Map must never be cleared unless advised by the YORK Factory.

The following conditions must be met before speed reduction is permitted:

- The PRV calibration procedure must have been performed.
- **Auto** speed control mode must be selected at the Keypad.
- Current Limit must not be in effect. When current limit is in effect, Valid Point LED CR8 is illuminated.
- The Leaving Chilled Liquid Temperature must be within +0.3 and -0.6°F of the Leaving Chilled Liquid Setpoint.
- The Chiller must have been running for >2 minutes.
- The Leaving Chilled Liquid temperature must be stable. Lowering the speed while this temperature is unstable, would tend to increase the instability. The Microboard calculates the stability by comparing the Leaving Chilled Liquid Temperature to the Leaving Chilled Liquid Temperature Setpoint to arrive at a rate of change value. This value is then compared to the programmed **Stability Limit Setpoint**. If the rate of change exceeds the Stability Limit Setpoint value, the Microboard sends a flag to the ACC Board. In response, the ACC Board starts a 60 second timer. **VALID POINT LED CR8** will be illuminated and speed decreases are prohibited until the timer has elapsed. Also, when making the transition from Manual speed control Mode to Auto Mode, the stability timer is started, preventing speed reduction for 60 seconds. The Stability Limit setpoint is programmed over the range of 1000 to 7000, by a qualified Service Technician using the procedure in the "System Calibration, Service Setpoints and Reset Procedures" section of this book. This value is a relative value that represents magnitude of stability. Higher values correspond to decreasing sensitivity. Default value of 4500 will provide proper operation in most applications.

When the chiller is started, the speed is brought to 60Hz. After it has been running for >2 minutes and the Leaving Chilled Liquid Temperature is within +0.3 and -0.6°F of the Leaving Chilled Liquid Temperature Set-

point, the ACC Board evaluates if the speed can be reduced. If there are no conditions above that would inhibit speed reduction, the ACC Board compares the real-time Delta P/P, PRV Position and motor speed to the 3-dimensional arrays stored in the **Surge Map**. If the real-time array does not match any previous surge condition, the speed will be decreased 0.1Hz every 6 seconds until it is within 1Hz of previously plotted surge condition array in the Surge Map. It will then be decreased 0.1Hz every 9 seconds until it's to the lowest value allowed by the Surge Map. If no plotted points are encountered, the speed is lowered until a surge is encountered or a minimum of 30Hz is reached.

The ACC Board uses two different methods of **Surge Detection**; Delta P method and DC Link method. Surge detection is only enabled while the chiller is running. In detecting a surge using the Delta P method, the outputs of the Evaporator and Condenser pressure Transducers are monitored to detect when the difference between these pressures (Delta P) drops transiently toward Zero. This would be indicative of a surge. A surge detected by the Delta P method must have all of the following conditions occur within 5 seconds to be considered a valid surge: a.) Delta P must make a negative transition and exceed 3.4 PSIG for 100 Milliseconds. B.) Delta P must also exceed 3.5 PSIG for at least 340 milliseconds. C.) Delta P must make at least 2 positive transitions. When this criteria is met, **Surge LED CR9** illuminates for 2 seconds, indicating a valid surge has been detected. In detecting a surge using the **DC Link** method, the VSD's DC Link Current is monitored to detect when the current drops transiently toward zero. This, as the case with Delta P method, is indicative of a surge. A surge detected by this method must also meet the following requirements to be considered a valid surge: a.) At least 6 **DC Link** surges must occur within 2 minutes, and b.) At least 3 **Delta P** surges have occurred within the 2 minute interval. When both these criteria have been met, **Surge LED CR9** illuminates for 2 seconds, indicating a valid surge has been detected.

Each time a Valid Surge is detected, the ACC Board increases the motor speed (up to a maximum of 60(50)HZ) to take the compressor out of surge. It also evaluates other chiller conditions to determine if the surge should be plotted on the **Surge Map**. Surges that occur during certain operating conditions are not plotted, as explained below. Whenever **Valid Point LED CR8** is illuminated, surges are not plotted.

After each surge, the speed is increased either 1.0Hz or 0.8Hz (plus the programmed **Surge Margin Adjust Setpoint**), depending on operating conditions, in the following increments:

- 0.1Hz every 2 seconds if motor current <80% FLA.
- 0.1Hz every 2 + (%FLA-80) if motor current >80% FLA but <98% FLA.
- 0.1Hz every 20 seconds if motor current >98% FLA.

If **Current Limit** is in effect, or the **Stability Timer** is running when a surge occurs, the speed is increased 1.0Hz but the surge is not plotted on the **Surge Map** since these conditions would produce an erroneous value. **Valid Point LED CR8** is illuminated as a visual indication that one or both of these conditions are in effect.

Otherwise, the speed is increased 0.8Hz (plus the programmed **Surge Margin Adjust Setpoint**) and the surge event is plotted on the **Surge Map**. The **Surge Margin Adjust Setpoint** can be used to add an extra margin of surge prevention. It is programmed over the range of 0.0 to 25.0Hz following instructions in the "System Calibration, Service Setpoints and Reset Procedures" section of this book. The Default value of 0 should provide proper operation in most applications.

When the speed has been increased either 1.0Hz or 0.8Hz (plus the **Surge Margin Adjust Setpoint**), as described above, this speed is maintained for the next 15 seconds. During this period, new surges are ignored. When the 15 seconds have elapsed, a 5 minute time period is entered where the speed is inhibited from decreasing, but increases are allowed. If a surge is detected within this 5 minute period, it is not plotted on the **Surge Map**, but the speed is increased by the amount as described above. This is repeated as long as the compressor continues to surge. The compressor must be surge free for 5 minutes before a speed decrease is permitted or another surge or another surge can be plotted on the **Surge map**.

The ACC Board counts the surges as they occur and sends a total count to the Microboard for display. The total surge count is not incremented if a different surge type occurs within 10 seconds of the previous surge. A Surge that occurs within 10 seconds of the previous surge is only counted if it is of the same surge type. For example, if a **Delta P** surge is detected and a **DC Link** surge is detected within 10 seconds, the **DC Link** surge

is not counted. If the **DC Link** surge occurred >10 seconds after the **Delta P** surge, it would be counted.

A surge point can be manually inserted into the **Surge Map** using the **Manual Surge Point** keypad key on the **ACC Details** screen and switch SW1 on the ACC Board as described in the "System Calibration, Service Setpoints, and Reset Procedures" section of this book. This is only to be used for situations in which the automatic surge detection described above does not respond to surge events. This is usually not required and is to be used only by qualified Service Technicians as a method of plotting a surge event that the ACC Board does not find on its own. At the instant the condition is identified as a surge event, **Surge LED CR9** illuminates for 2 seconds. The motor speed, **Delta P/P** and **PRV Position** at the instant the point is established, is unconditionally plotted as a 3-dimensional array in the **Surge Map** as a surge condition, regardless of whether or not **Valid Point LED CR8** is illuminated. The motor speed will be automatically increased as described above. Once plotted, the ACC Board will respond to this point in exactly the same way it responds to automatically plotted surge points, as described above.

Surge points can be printed from the **ACC Details** Screen. The entire stored **Surge Map** can be printed using the **Surge Map Print** keypad key. Also, the surge points can be printed in real-time as they occur, using the **Auto Print** keypad key. Since the maximum rate at which new surges can be plotted is every five minutes, the rate at which new points are printed is also every five minutes.

When the **PRV's** approach their 100% open position, there is very little **PRV** movement remaining to compensate for an increasing load condition. Therefore, in **Auto** speed control mode, if there is no **Current Limit** in effect, and the **PRV** position reaches >98%, the speed is automatically increased at a rate based on the **Delta T** between the **Leaving Chilled Liquid** temperature and the **Leaving Chilled Liquid** temperature Setpoint as follows:

- 0.1Hz every 10 seconds if **Delta T** is >0.2 and <0.5°F.
- 0.1Hz every 8 seconds if **Delta T** is >0.5 and <0.9°F.
- 0.1Hz every 6 seconds if **Delta T** is >0.9°F.

If **Delta P/P** ever increases to >3.60, the speed will be slowly increased to 60Hz. If this were to occur, **Delta P/P** would have to decrease to <3.55 before a speed decrease would be allowed.

The microprocessor is the center point of the hardware architecture (Fig. 45). It coordinates the serial data communications between the Control Center Microboard and the VSD Logic Board and Harmonic Filter Logic Board. This serial data is in 0v/+5VDC form. YM XMT (CR7) and YM RCV (CR6) LED's illuminate during serial communications with the Control Center Microboard. Similarly, VS XMT (CR5) and VS RCV (CR4) LEDs illuminate during serial communications with the VSD Logic Board. Serial communications with the Harmonic Filter logic Board take place through the microprocessor via the Digital Signal Processor. This data is accompanied by a Framing pulse and a CLK signal. Although Evaporator and Condenser pressures are transmitted to the ACC Board via the serial communications link for **Delta P/P** calculation, these pressures are also applied directly from the Microboard to the **MUX** (multiplexer) for **Delta P** surge detection. Also applied to the MUX, is the output of the PRV position Potentiometer. Under program control, these values are input to the microprocessor. The EPROM contains the operating Program for the ACC Board. The RAM serves as the scratch pad memory. The BRAM is a battery backed memory device where the Surge Map is stored. The Watchdog circuit maintains the microprocessor in a reset state during low voltage conditions.

This prevents the microprocessor from reading/writing or processing data until it and supporting circuits have sufficient supply voltage. The Watchdog also assures that the entire Program is executed and that no Program latch-ups occur. **Surge LED CR9** illuminates for 2 seconds when a valid surge condition has been detected as explained above. **Valid Point LED CR8** illuminates whenever there is a condition in effect that prevents a Surge from being plotted on the **Surge Map**. These conditions are: a.) Current Limit is in effect b.) Leaving Chilled Liquid Temperature Stability Timer is running, indicating an unstable control condition c.) Speed control is in **MANUAL** mode. Switch SW1 is used to manually insert (plot) a surge point in the **Surge Map**.

Test points are provided as follows:

- TPA: +5VDC supply voltage.
- TPB: supply voltage ground.
- TPC: Watchdog power failure detected. Normally >+4.5VDC. Transitions to logic low (<3.5VDC) during low voltage conditions.
- TPD: Harmonic Filter Logic Board 0/+5VDC 1200 baud serial data.
- TPE: Harmonic Filter Logic Board Frame pulse.

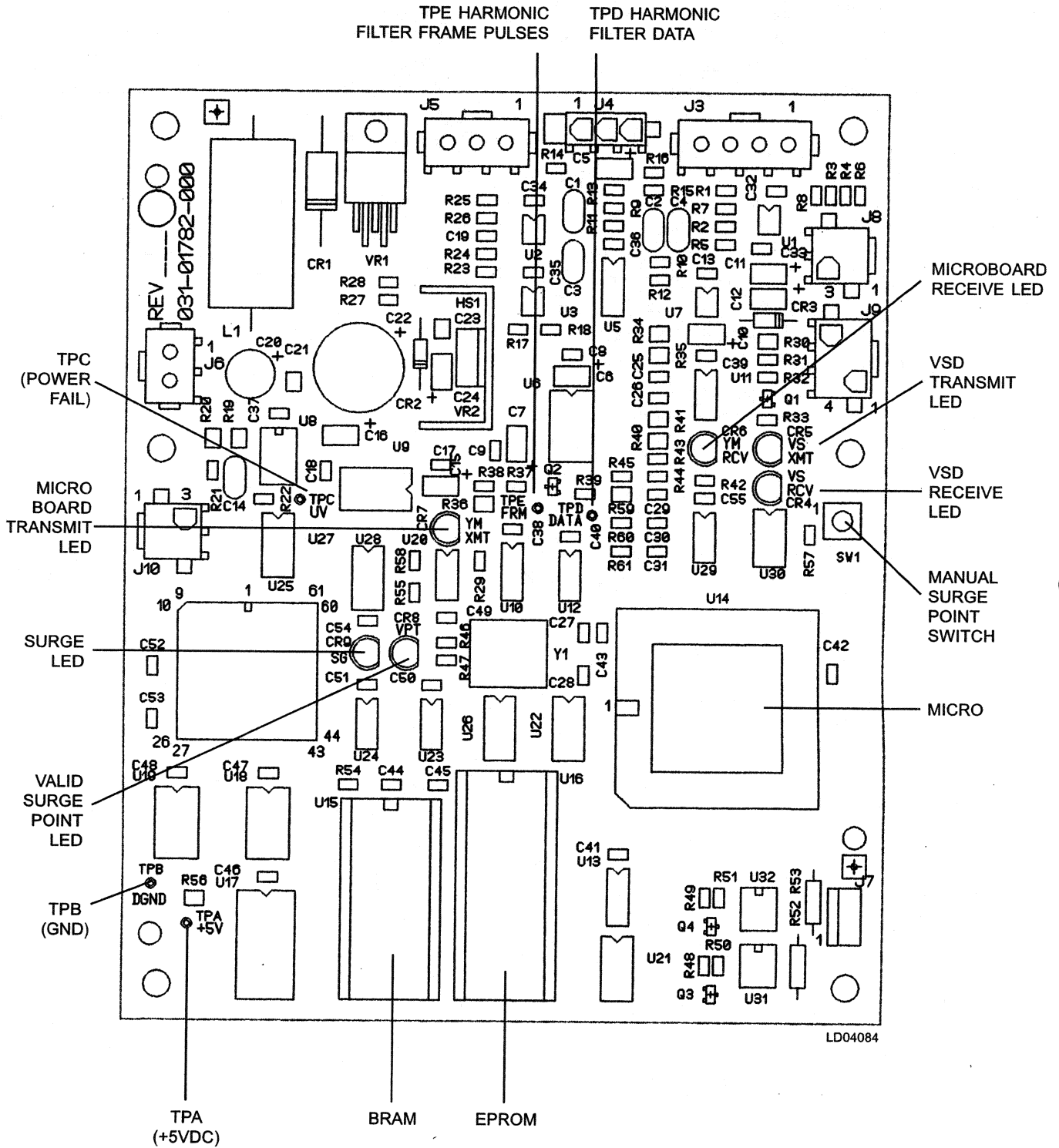

FIG. 43 – COMPRESSOR MOTOR VARIABLE SPEED DRIVE (VSD) ADAPTIVE CAPACITY CONTROL (ACC) BOARD

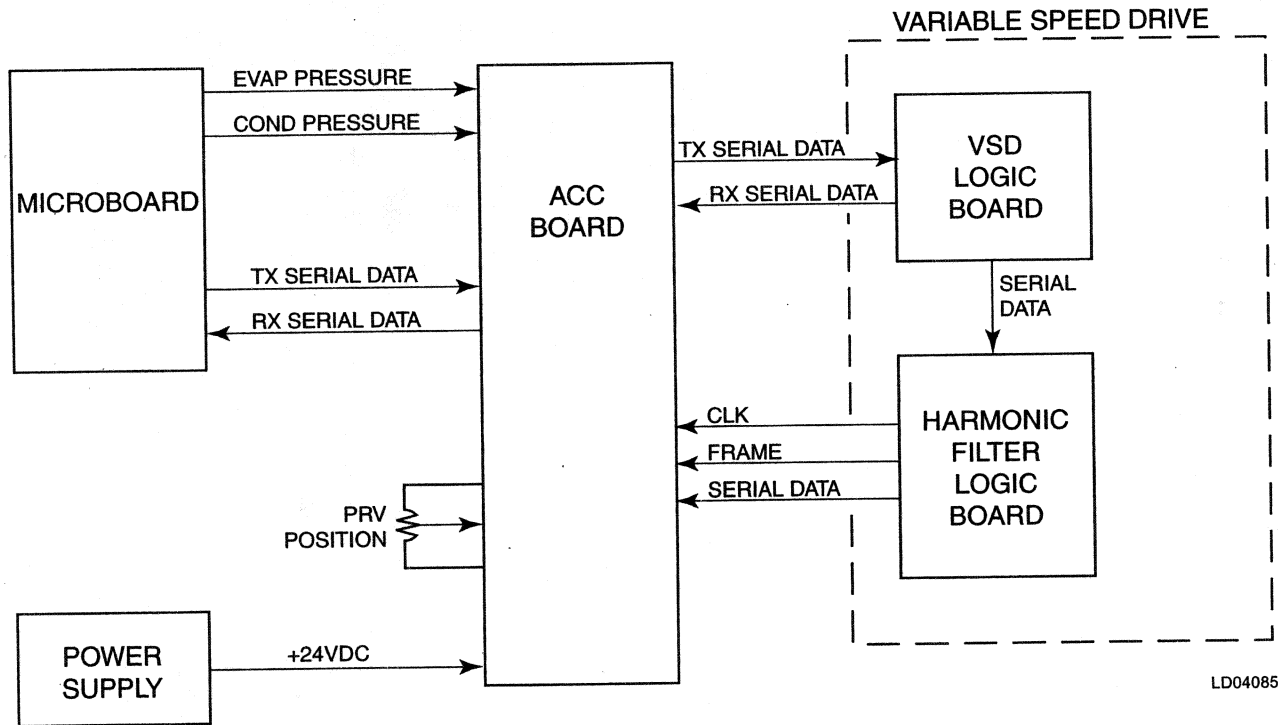
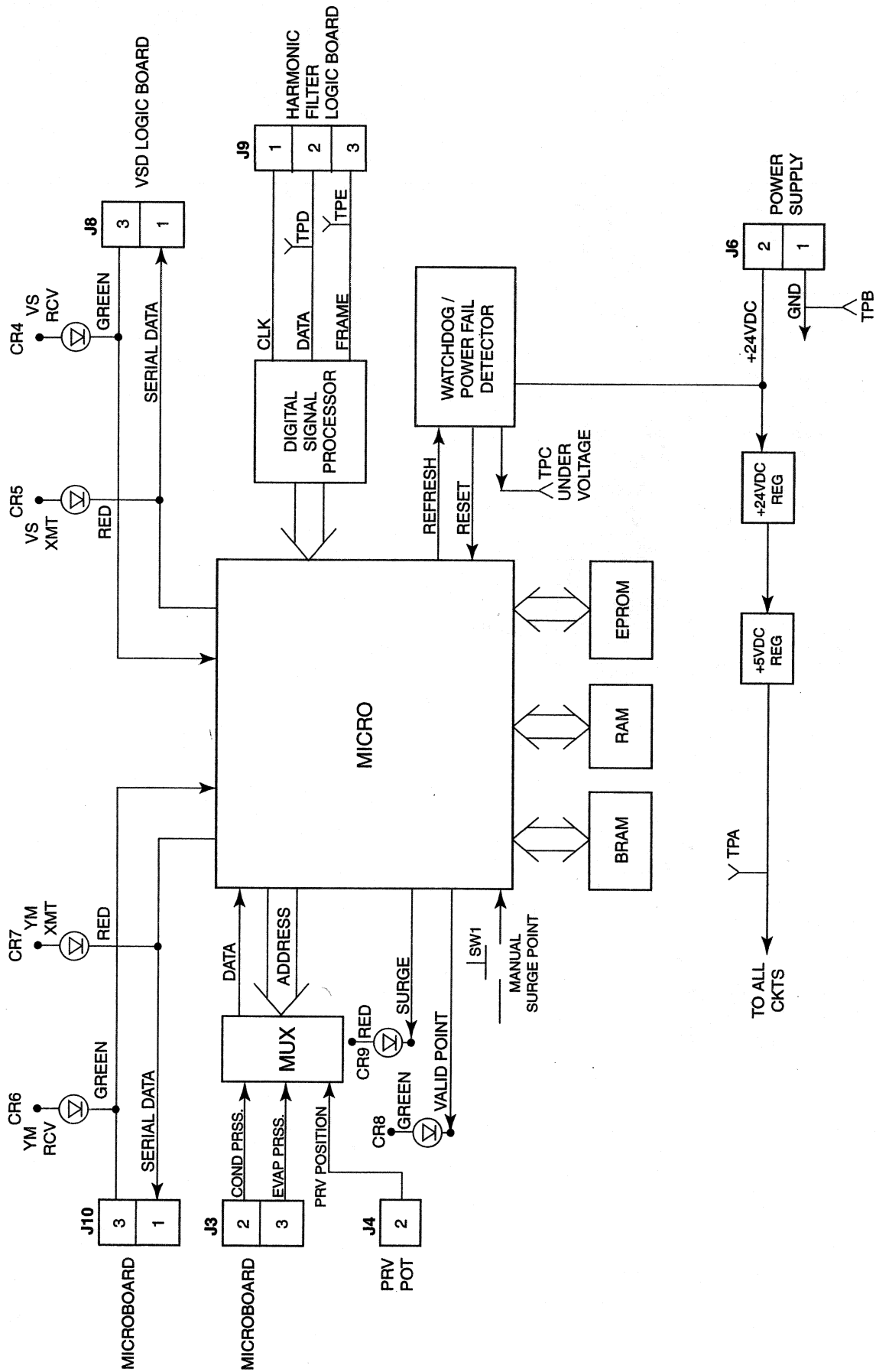

FIG. 44 – ADAPTIVE CAPACITY CONTROL (ACC) BOARD - INTERFACE



LD04086

FIG. 45 - ADAPTIVE CAPACITY CONTROL (ACC) BOARD

SECTION 13

PURGE SYSTEM

(REFER TO FIG. 46 - 49)

The Purge System automatically removes air and other non-condensibles from the condenser. Air in the system blankets some of the condensing surface, causing an increase in the discharge pressure and temperature, causing surging or high condenser pressure shutdowns. Moisture in the system causes acid formation that is destructive to internal parts.

There are two different types of Purge systems that could be applied, depending upon the chiller vintage. New production chillers are supplied with a pump assisted **High Efficiency** purge system. Earlier chillers, such as those encountered in retrofit applications, are not equipped with a pump and operate at lower pressures. Otherwise operation is the same for both types. If the chiller is equipped with the pump assisted purge system, High Efficiency operation must be **ENABLED** using the procedure in the "System Calibration, Service Setpoints and Reset Procedures" Section of this book. Otherwise, to provide proper operation on those chillers not equipped with the High Efficiency purge system, the High Efficiency operation must be **DISABLED**. In the explanations below, pressure thresholds applicable to those systems not equipped with a pump are shown in parentheses.

The purge system consists of the following components:

- **Purge Tank** - A tank in which the non-condensibles are compressed and vented.
- **Purge Oil Pump** - Fills the Purge Tank with oil to compress the non-condensibles.
- **Purge Oil 3-way Solenoid Valves** - Directs oil either into (fill) or out of (drain) the Purge tank.
- **Purge Air Exhaust Solenoid Valve** - Opens to vent non-condensable gases.
- **Purge Tank Pressure Transducer** - Provides analog voltage representing Purge Tank pressure to Microboard. Refer to Fig. 53 for pressure-to-voltage conversion formula.
- **Top Float Switch** - Indicates "FULL" Purge Tank oil level to Microboard.
- **Bottom Float Switch** - Indicates "EMPTY" Purge Tank oil level to Microboard.

While the chiller is running, a mixture of non-condensable and refrigerant gases from the top of the condenser are expelled into the bottom of the Purge Tank. The Microboard energizes the Oil Solenoid Valves to direct oil from the Purge Pump into the bottom of the Purge Tank. The Purge Pump runs constantly while the chiller is running. Liquid refrigerant from the condenser flows through a coil inside the tank and is returned to the evaporator. This cools the oil to aid separation of the non-condensibles from the oil. As the oil level increases in the tank, it rises above the Bottom Float Switch causing it to open. If there are any non-condensibles in the mixture, the pressure in the top of the tank will increase as they are compressed by the rising oil level. When the pressure increases to >90.0 (34.7) PSIA, as sensed by the Purge Pressure Transducer, the Microboard energizes (opens) the Air Exhaust Solenoid Valve, venting the air and non-condensibles and causing the tank pressure to decrease. When the pressure decreases to < 80.0 (29.7) PSIA, the Microboard de-energizes (closes) the Exhaust Solenoid Valve. This venting, based upon pressure, continues until the oil level rises to the Top Float Switch, causing it to open. The opening of both Float Switches signals the Microboard that the Purge Tank is full of oil. The Microboard then de-energizes the Oil Solenoid Valves, causing the oil to be pumped from the Purge Tank. As the oil level decreases below both the Top and Bottom Float Switches, they will both be closed. This signals the Microboard that the Purge Tank is empty and it energizes the Oil Solenoid Valves to cause the fill cycle and venting to repeat.

While the chiller is shut down, the Microboard shuts down the Purge Pump, de-energizes (closes) the Air Exhaust Solenoid Valve and de-energizes the Oil Solenoid Valve, initiating a drain cycle.

To prevent the Purge Tank pressure from reaching an excessively high level, the Purge Tank High Pressure (PTHP) switch opens at 105.0 PSIA. This stops the Purge Pump and prevents any further increases in pressure. The PTHP device will remain open until the pressure decreases ≤ 99.0 PSIA and it is manually reset. While the chiller is running, if the pressure in the Purge Tank, as sensed by the Purge Transducer, increases to

> 95.0 (55.0) PSIA continuously for 4 minutes, “**Warning - Purge - High Pressure**” is displayed and alarm contacts (TB2-55/56) close. This message will clear and the alarm contacts will open after the pressure decreases to ≤ 95.0 (55.0) PSIA (or the chiller is shutdown) and the **WARNING RESET** key is pressed on the **HOME** Screen in **OPERATOR** (or higher) access level. If a Purge Float Switch Error is present, as detailed below, the warning message is not displayed.

To assure the float switches are accurately depicting the oil level in the Purge tank, the position of both switches are compared while the chiller is running. Normally, when the oil level is at minimum (empty), the oil level is below both the Top Float Switch and Bottom Float Switch, causing both switches to be closed. When the oil level is at maximum (full), the level is above the Bottom Float switch and up to the Top Float switch, causing both switches to open. For levels between these extremes, the Bottom Float switch is open and the top Float Switch is closed. However, if the Bottom Float switch is closed and the Top Float switch is open, this would indicate the level is simultaneously below the Bottom switch and above the Top switch, an invalid condition. If this condition occurs, “**WARNING - PURGE - FLOAT SWITCH ERROR**” is displayed, alarm contacts (TB2-55/56) close and the Microboard de-energizes the Oil Solenoid Valve, performing a drain cycle. This message will clear and the alarm contacts will open, after the Float Switches are indicating acceptable states (or the chiller is shut down) and the **WARNING RESET** key on the **HOME** Screen is pressed in **OPERATOR** (or higher) access level. The purge fill and drain cycles will then continue.

The **PURGE** Screen, accessed from the **CONDENSER** Screen, displays a cutaway view of the Purge tank. LED's depict the state of the Top Float Switch, Bottom Float switch, Oil Solenoid Valve and Air Exhaust Solenoid Valve. When a Float switch is closed, the applicable LED is illuminated. The Oil Solenoid Valve LED illuminates when the valve is energized, filling the Purge Tank with oil. It is extinguished during a drain cycle. The Air Exhaust Solenoid Valve LED illuminates when the valve is energized (open), allowing non-condensibles to escape the Purge Tank. Otherwise, it is extinguished. The **HIGH EFFICIENCY** Purge Enable/Disable key is only displayed when logged in at **SERVICE** access level. The pressure in the Purge Tank, as sensed by the Purge Transducer, is displayed. The number of air exhausts that have occurred within the last

0-60 minutes, as explained below, are displayed as the **EXHAUST COUNT** and **EXHAUST WINDOW** respectively. The programmed **MAXIMUM PURGES/HOUR** Setpoint is also displayed. Animation, based on the position of the float switches, depicts the oil level in the Purge Tank. When both the Bottom and Top Float switches are closed, the oil level is shown at its lowest or empty level. When both float switches are open, the level is shown at its highest or full level. For levels between these extremes, the level is shown at midpoint.

Each time the chiller is started, air exhausts are not counted for the first 60 minutes of chiller operation. During this time, a countdown timer displays the minutes remaining in the exhaust count bypass. After the first hour has elapsed, air exhausts are counted and displayed as the **EXHAUST COUNT**, as the **EXHAUST WINDOW** increments from 0 to 60 in 1 minute intervals. The air exhausts displayed are those that have occurred in the last “X” minutes since the 60 minute bypass timer has elapsed. After the **EXHAUST WINDOW** reaches 60, the air exhausts that occurred in the oldest minute are discarded and exhausts from the most recent minute are shifted in, providing a rolling count of air exhausts that have occurred in the last 60 minutes. This continues until the exhaust count equals the programmed **MAXIMUM PURGES/HOUR** setpoint (see below) or the chiller is shut down. Either of these conditions freezes the exhaust count until the chiller is restarted, whereupon the **EXHAUST COUNT** and **EXHAUST WINDOW** are reset to zero.

The **MAXIMUM PURGES/HOUR** setpoint provides a means of evaluating the rate of purging. This setpoint can be programmed over the range of 10 to 30 purges/hour (Operator access level) or 1 to 30 purges/hour (Service access level) following instructions in the “System Calibration, Service Setpoints and Reset Procedures” section of this book. The default value for both access levels is 20. When the actual number of air exhausts within a 1 hour period equals the programmed setpoint value, “**WARNING - EXCESS PURGE**” is displayed, Alarm contacts (TB2-55/56) close and the **EXHAUST COUNT** is frozen. Although air exhausts will continue, the **EXHAUST COUNT** will not increment. To clear the warning message, open the alarm contacts and allow air exhausts to be counted. An Operator, logged in at **OPERATOR** access level, can press the **WARNING RESET** key on the **HOME** Screen.

LOWER EMISSIONS PURGE SYSTEM (ref. Fig. 48 and 49)

The optional Lower Emissions Purge System consists of two 5-lbs capacity canisters piped in series between the Purge Tank outlet and the purge vent line. Purge exhausts from the Purge Tank pass through canister number 1 to canister number 2 and then on to the vent line. Refrigerant is collected in the canisters and the non-condensables pass through to the vent line. Since the exhaust first passes through canister number 1, it will become full before number 2. A Purge Canister Alarm mounted on canister number 1 detects when the first canister is full. When full, the sensor's red light and buzzer alarm are activated and "Warning - Purge - Canister #1 Full" is displayed.

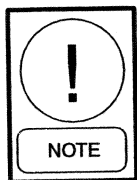

**Flash Memory Card version
C.MLM.02.02.xxx and later required
to display message.**

When canister number 1 becomes full, it must be removed and returned to the reclaim facility named on the canister. The complete canister replacement procedure is detailed on a label inside the Purge Panel Door and in YORK Operations Manual 160.55-O1.

The Purge Canister Alarm is powered from a +12VDC Power Supply (PS1) that is located in the Purge Panel. The Power Supply operates from a 115VAC source. A

two-state analog alarm output from P2 to Microboard J8-1 triggers the warning message when canister number 1 is full. This signal transitions from 0VDC to 5VDC when the canister is full. Any signal level $\geq 2.20\text{VDC}$ will trigger the message. The Warning message can be manually cleared using the Warning Reset key when the signal is $\leq 0.90\text{VDC}$.

The canister replacement procedure requires that power be removed from the Alarm while the canister is replaced. To eliminate the need to disconnect wiring, a pushbutton is supplied on the side of the Purge Panel that interrupts AC power to the Alarm Power Supply for up to 5 minutes (as set with time delay relay 2R) as follows: Momentary pushbutton PB1 (located in the Purge Panel) operates relay 2R to interrupt the power to the Purge Canister Alarm. This plug-in relay is a time delay type. The delay can be adjusted for 3-300 seconds. In this application, it should be set for 300 seconds (5 minutes). The delay is initiated by a momentary switch closure between relay socket terminals 5 and 7. The relay's normally closed R2-1 contacts from relay socket terminals 1 and 4 are connected in series with the 115VAC source to the Alarm Power Supply. Switch PB1 is connected to terminals 5 and 7 of the relay socket. Pressing and releasing PB1 causes a momentary closure between these terminals that causes the relay to energize and remain energized for the duration of the set time delay. While energized, contacts R2-1 open, interrupting the AC power to the Alarm Power Supply. When the time delay has elapsed, the relay de-energizes and contacts R2-1 Close, restoring power to the alarm.

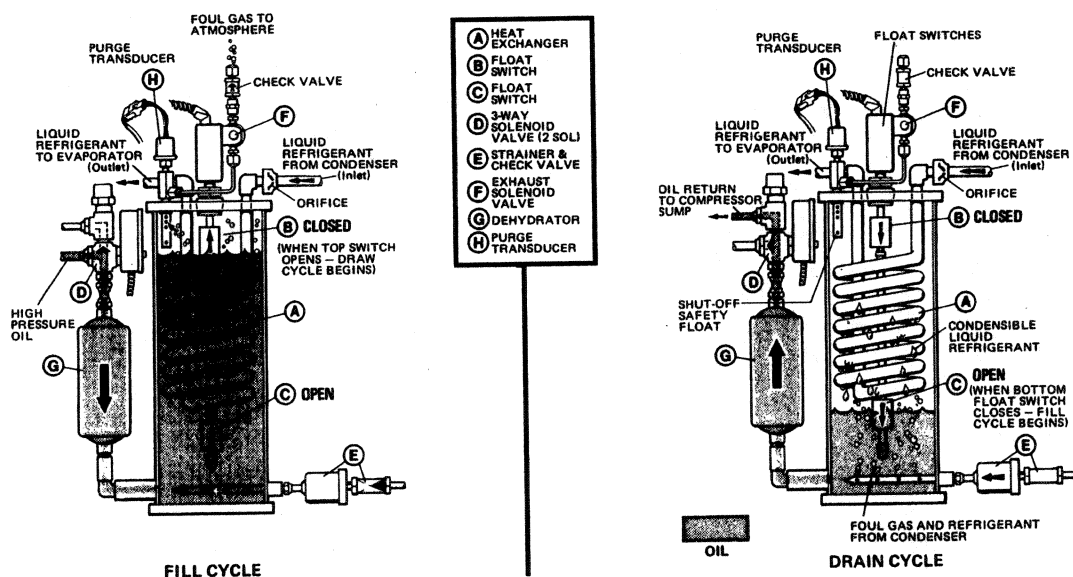
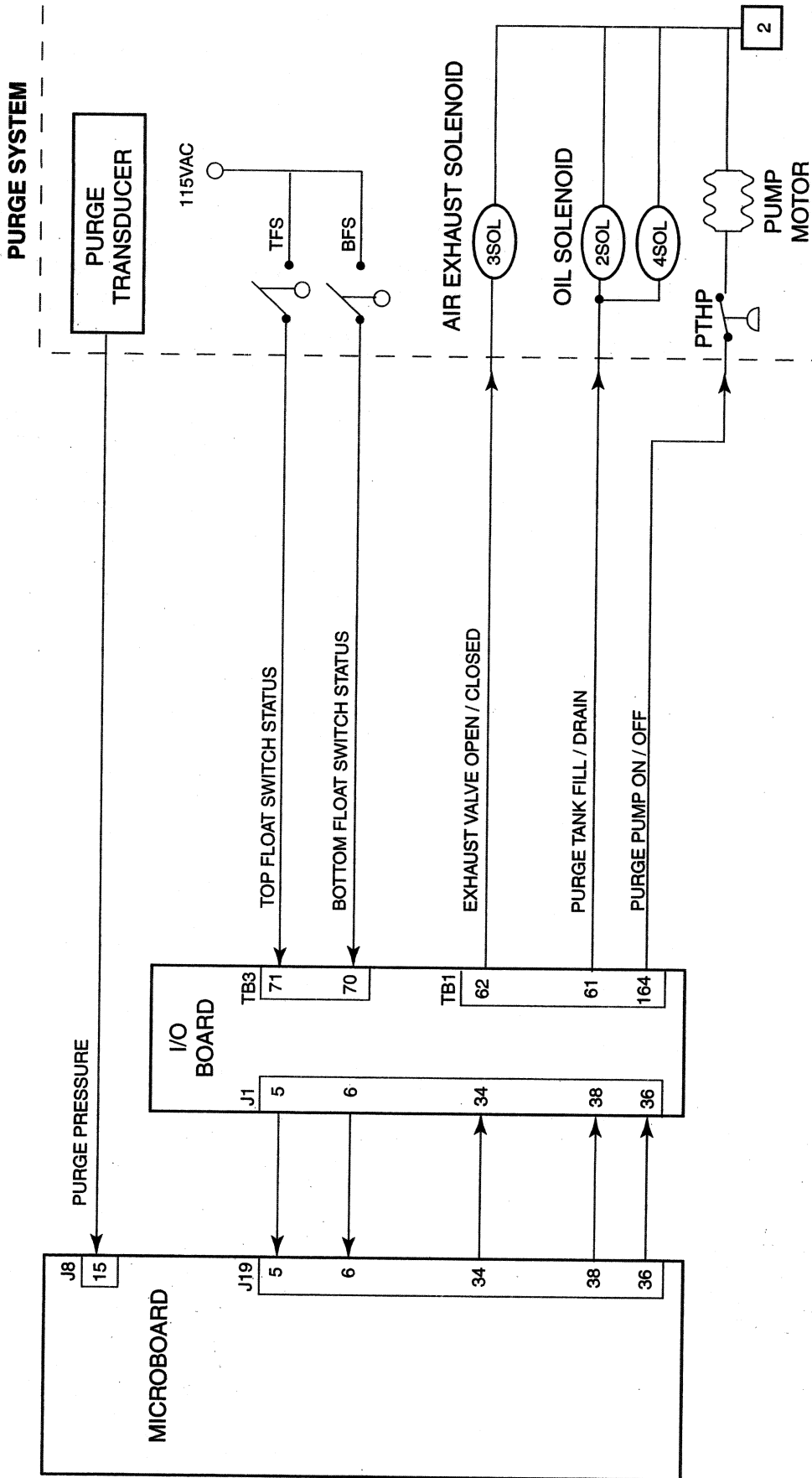

FIG. 46 - PURGE SYSTEM



LD04650

FIG. 47 - HIGH EFFICIENCY (PUMP ASSISTED) PURGE SYSTEM - INTERFACE

LD06627

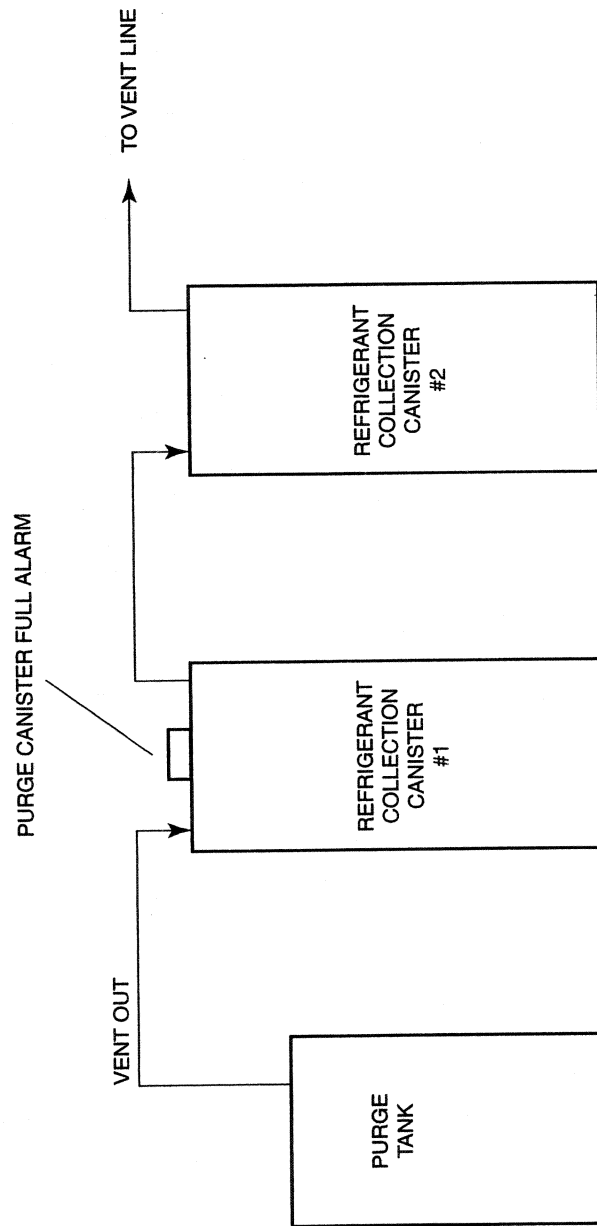
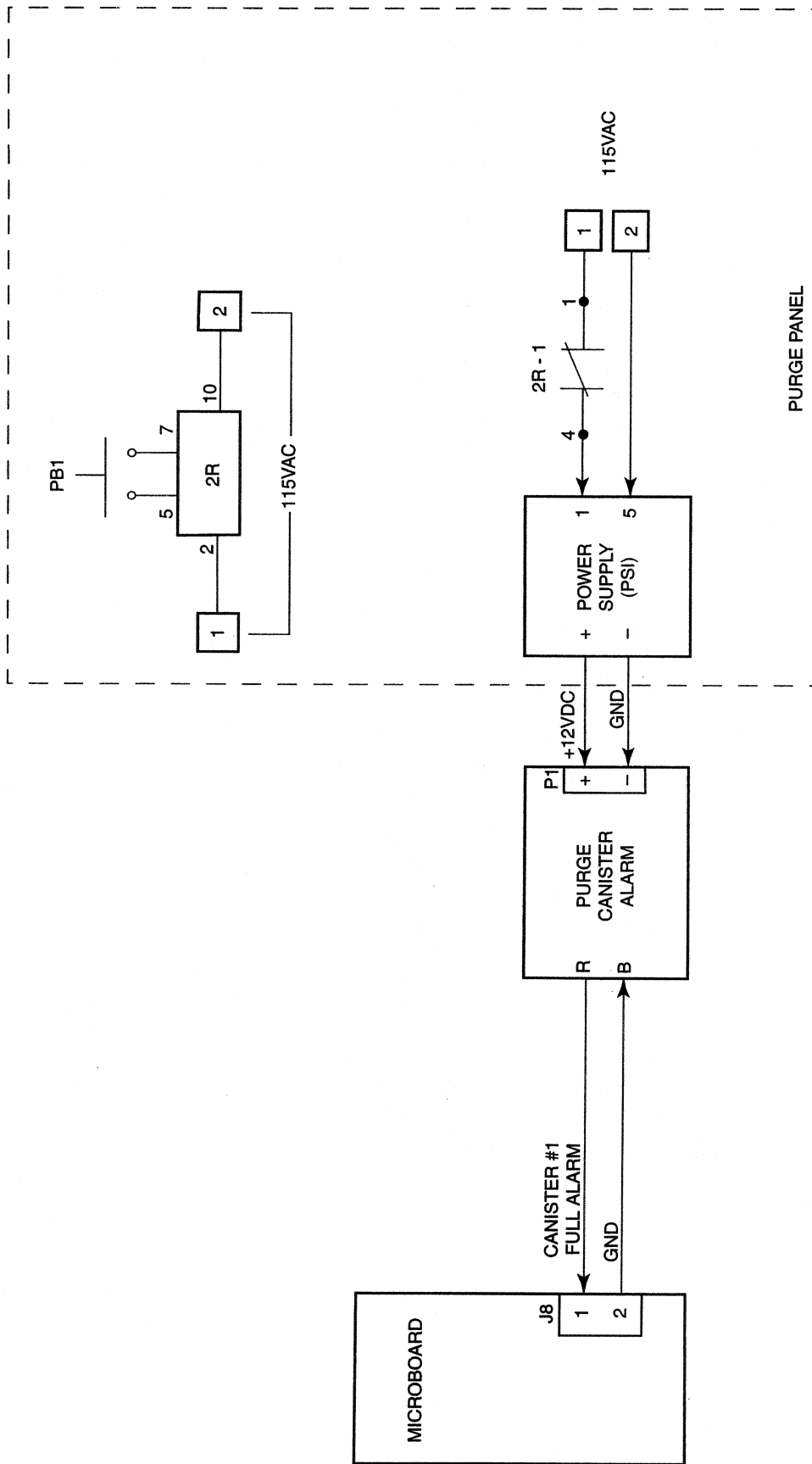

FIG. 48 - LOWER EMISSIONS PURGE SYSTEM



LD06528

Pushbutton PB1 and 2R relay are used to remove power from the Purge Canister alarm during canister replacement. Refer to "Purge System" section of this book.

FIG. 49 - LOWER EMISSIONS PURGE SYSTEM - PURGE CANISTER ALARM INTERFACE

SECTION 14

REFRIGERANT LEVEL CONTROL

(REFER TO FIG. 50 & 51)

14

The chiller can be provided with an optional **Condenser Refrigerant Level Control**. This feature is supported by Flash Memory Card version C.MLM.02.01.100 or C.MLM.02.01.200 and later versions. A **Variable Orifice**, located in the refrigerant liquid line between the Evaporator and Condenser, is used to control the refrigerant level in the Condenser. It is modulated by an **Actuator** that is driven by open and close output signals from Triacs on the I/O Board. These control signals originate at the Microboard. Automatic or Manual level control is allowed. If Automatic control is selected, the Program modulates the Variable Orifice to maintain the Condenser refrigerant to a programmable Setpoint level. If Manual control is selected, the Variable Orifice can be manually controlled with the Keypad keys. This Manual control can also be used to place the Orifice in a fixed position.

Since the Level Control feature is optional, the Program operation described here must be **ENABLED** on those chillers so equipped and **DISABLED** on all other chillers. This procedure, along with the programming of Setpoints described below, is performed on the Refrigerant Level Control/Tuning Screen using instructions in the "System Calibration, Service Setpoints and Reset Procedures Programming Procedures" section of this book.

The refrigerant level in the Condenser is expressed as a percentage; 0% = empty, 100% = full. A **Liquid Level Sensor (LLS)** detects the refrigerant level in the Condenser and outputs an analog voltage to the Microboard that represents this level; 0.50VDC = 0%, 5.00VDC = 100%. This is the **Level Position** and is displayed as "Refrigerant Level Position= xxx%" on the Condenser Screen. The desired level to be maintained is the **Level Setpoint** and is displayed as "Refrigerant Level Setpoint = xx%" on the same screen. This Setpoint is programmed by a Service Technician at chiller commissioning using the Refrigerant Level Control Screen. It is programmable over the range of 20% to 80%.

AUTOMATIC OPERATION

While the chiller is shut down, an Open signal is applied to the Actuator, driving the Orifice to the fully open position. This causes the Condenser refrigerant level to be approximately 0%. Elevated Evaporator pressure with respect to Condenser pressure could cause the level to be higher.

After the chiller is started, when the Vane Motor Switch (VMS) opens after entering **SYSTEM RUN**, if the actual level is greater than the Level Setpoint, the Microboard begins controlling the level to the Level Setpoint. However, if the actual level is less than the Level Setpoint, a linearly increasing ramp is applied to the Level Setpoint. This ramp causes the Setpoint to increase from the initial refrigerant level to the programmed Level Setpoint over a period of 15 minutes. While this ramp is in effect, the ramp value is displayed as **REFRIGERANT LEVEL TARGET = XX%** and replaces the Level Setpoint message on the Condenser Screen. While the ramp is in effect, **RAMP UP TIME REMAINING = XX MIN** is displayed. After the 15 minute ramp period has elapsed, the refrigerant level is controlled to the programmed Level Setpoint.

While the chiller is running, the refrigerant level is normally controlled to the Level Setpoint. However, anytime the Pre-rotation Vanes (PRV) fully close causing the Vane Motor Switch (VMS) to close, the following occurs: a.) normal level control is terminated. b.) any refrigerant level setpoint ramp that is in effect is canceled. c.) the control signals to the Orifice Actuator will be opposite of the signals applied to the PRV motor (i.e.; if a close signal is being applied to the PRV motor, an open signal will be applied to the Orifice Actuator). When the VMS opens, if the refrigerant level is less than the Level Setpoint, a setpoint ramp is initiated as previously described. If the refrigerant level is greater than the Level Setpoint when the VMS opens, the level is controlled to the Level Setpoint.

If the Liquid Level Sensor output ever increases to greater than 4.4VDC, indicating a level greater than 100%, **WARNING - REFRIGERANT LEVEL OUT OF RANGE** is displayed and the Orifice Actuator is driven open until the level has decreased to a level within range. When within range, the warning message is automatically cleared and normal control is resumed.

The Program applies an open or close signal, as required, from the Microboard to the actuator to maintain the level to the Level Setpoint. The duration of the signal determines the magnitude of change to the Orifice position. The duration of the signal and whether it is an open or close signal depends upon the Proportion Error and the Rate of Change of the actual level compared to the Level Setpoint in a recurring period of time called a **Level**

Control Period. At the end of each Level Control Period, the Proportion error and Rate of Change are compared to Programmable Setpoints **Proportion Limit Close, Proportion Limit Open and Rate Limit Close and Rate Limit Open.** The result of this comparison determines the signal that will be applied to the Actuator at the end of the Level Control Period as follows:

The entire chiller run time is divided into Level Control Periods. They occur consecutively and continuously. The first one begins upon entering **SYSTEM RUN** and when it ends the next one begins, etc. This repeats until the chiller is shutdown. The duration of these periods are programmed as the **Level Control Period Setpoint** over the range of 1.0 to 5.0 seconds. At the completion of each Level Control Period, the actual level is compared to the Level Setpoint. The result is the Proportion Error ($\pm 3\%$ is considered zero). The Proportion Error is compared to Setpoints Proportion Limit Open (if level is above setpoint) and Proportion Limit Close (if level is below setpoint). Both of these Setpoints are programmable over the range of 10% to 50%. If the Proportion Error exceeds the Limit Setpoint, the Proportion Error influence in the response will be large. If the Proportion Error is less than the Limit Setpoint, the Proportion error influence in the response is determined by how close the Proportion Error is to the Limit Setpoint; close yields larger influence, further yields smaller influence. To establish the response to the rate of change, the amount of change in the Level within the Level Control Period ($\pm 1\%$ is considered zero) is compared to the Rate Limit Close (if level less than setpoint) and Rate Limit Open (if level

greater than setpoint) Setpoints. Both are programmable over the range of 10% to 50%. If the result exceeds the Setpoint, the rate influence in the response will be large; if less than the Setpoint, the rate influence is determined by how close the result is to the Setpoint; close yields larger influence, further yields smaller influence.

Therefore, per the above, the values programmed for Proportion Limit Open/Close and Rate Limit Open/Close determine the sensitivity of the level control. Smaller values generally yield greater response for the same level change in the Level control Period. Also, the smaller the value programmed for the Level Control Period, the more often an output signal is applied to the Variable Orifice Actuator.

The orifice valve movement is animated on the Refrigerant Level Control Screen as follows: when 0 - 20% open, shown fully closed; 20 - 40% open, shown as 20% open; 40 - 60% open, shown as 40% open; 60 - 80% open, shown as 80% open; 80 - 100% open, shown as 100% open.

MANUAL OPERATION

The Orifice Actuator can be manually controlled from the Keypad using the Refrigerant Level Control Screen after logging in at **SERVICE** access level. Open, Close, Hold and Auto keys are used to control the Variable Orifice. Using the Open, Close and Hold keys, the Variable Orifice can be placed in a fixed position. Pressing the Auto key returns Level Control to Automatic operation.

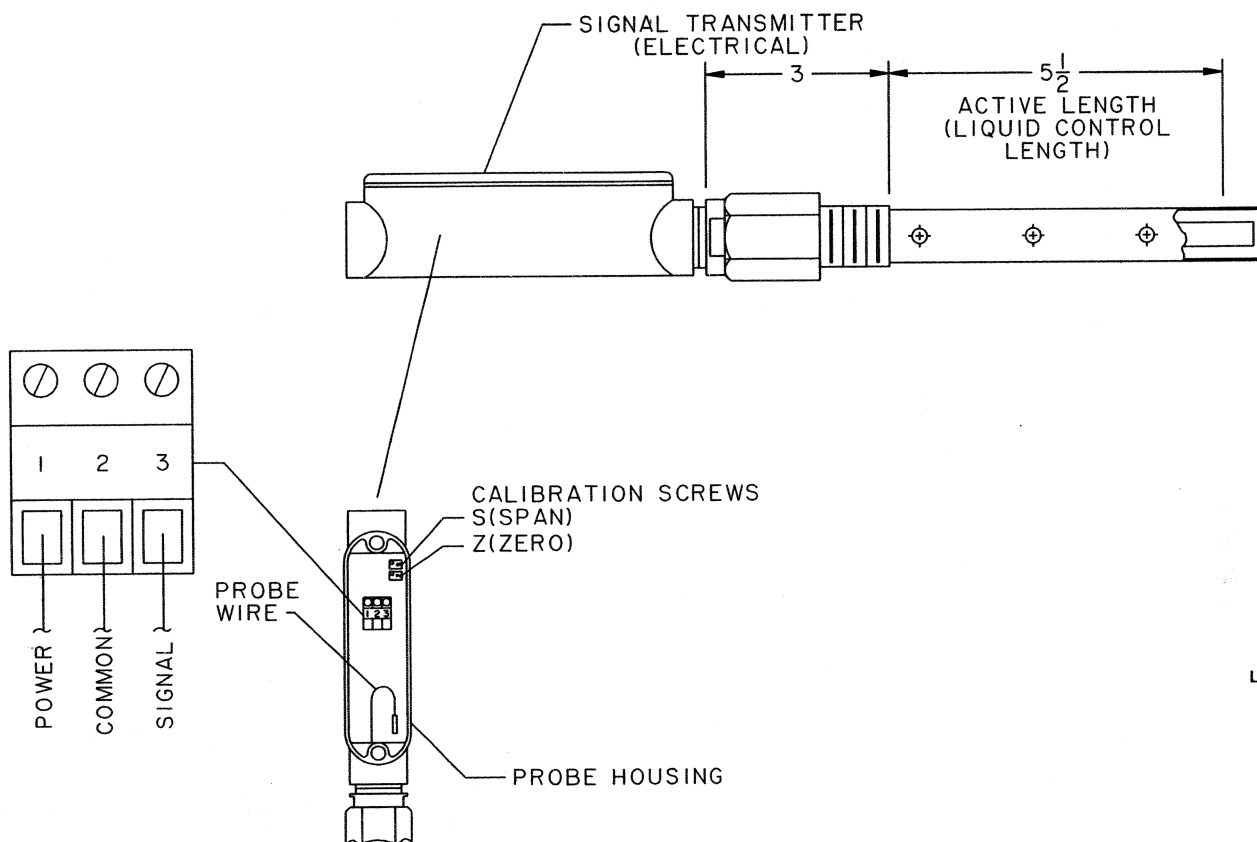

LD04091

FIG. 50 - REFRIGERANT LIQUID LEVEL SENSOR

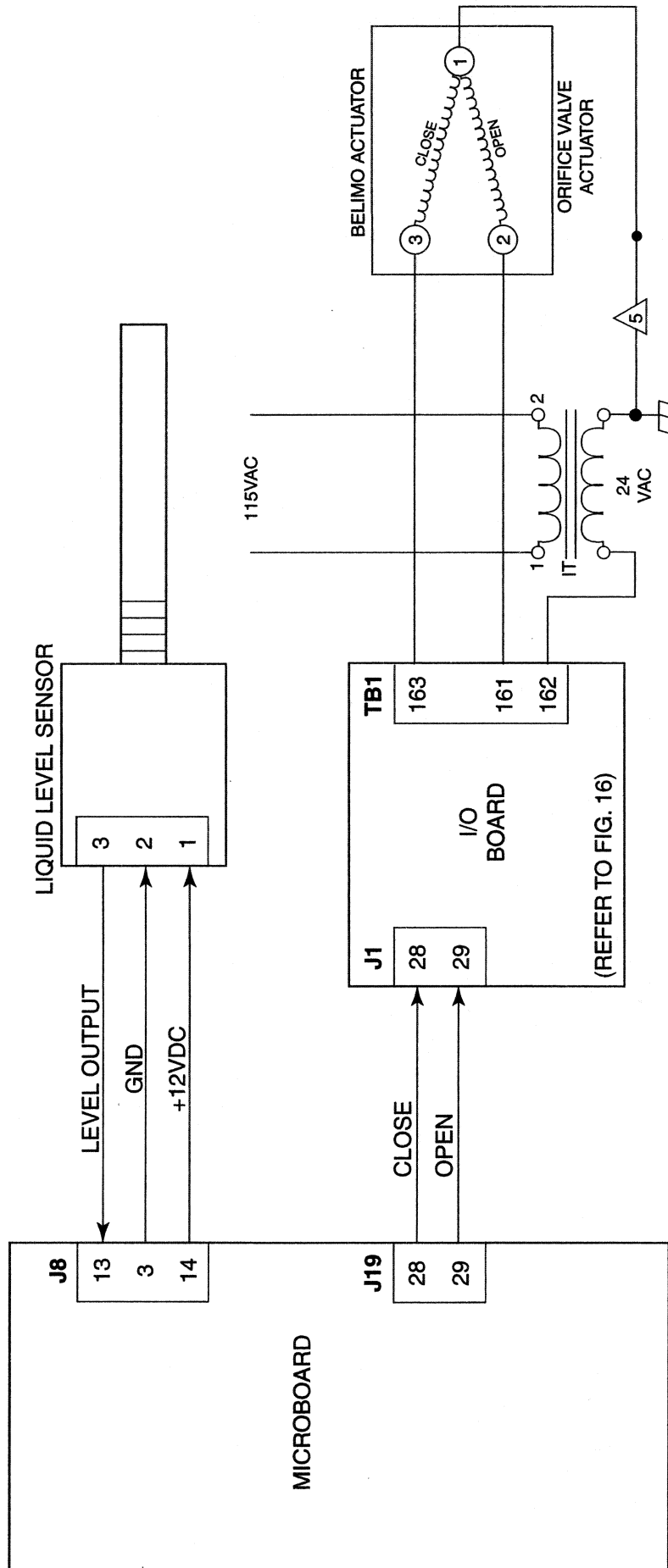

LD05821

FIG. 51 - REFRIGERANT LIQUID LEVEL CONTROL - INTERFACE

SECTION 15

MICROGATEWAY

(REFER TO FIG. 52)

The complete description of the MicroGateway installation and operation is contained in YORK Form 450.20-NOM1.

The MicroGateway is an optional printed circuit board that provides an interface between the OptiView Control Center and YORK ISN (Integrated Systems Network) or other selected networks. It can be mounted on the upper corner of the left wall of the OptiView Control Center or in its own enclosure in a remote location.

If installed in the OptiView Control Center, the MicroGateway is powered by +12VDC from the Microboard.

The MicroGateway communicates with the Microboard COM 4B communications port via an RS-232 interface (ref. Fig. 52). As shown in Figure 9, Microboard Program Jumper JP 27 must be placed on pins 2 and 3 to allow data to be received from the MicroGateway.

If the remote device that is connected to the MicroGateway is going to provide remote Start-Stop signals, remote Leaving Chilled Liquid Temperature

and/or remote Current Limit Setpoint resets, the Control Source must be set to ISN on the OPERATIONS Screen. Otherwise, communications will take place in any Control Source mode.

In operation, the Microboard provides chiller pressures, temperatures and status to the MicroGateway in response to requests from the MicroGateway. Microboard status LED's illuminate when the Microboard transmits and receives data on COM 4B. Green LED CR13 (RX4) illuminates when data is being received from the MicroGateway. Red LED CR12 (TX4) illuminates when data is being transmitted to the MicroGateway. Similar LEDs on the MicroGateway annunciate data transfer to/from the Microboard (refer to 450.20-NOM1).

If there is a communications problem between the Microboard and MicroGateway, use the LEDs described above to analyze the problem. The COM 4B Loop Back test can be used to verify operation of the Microboard COM 4B communications port. Refer to Diagnostics and Troubleshooting section of this book.

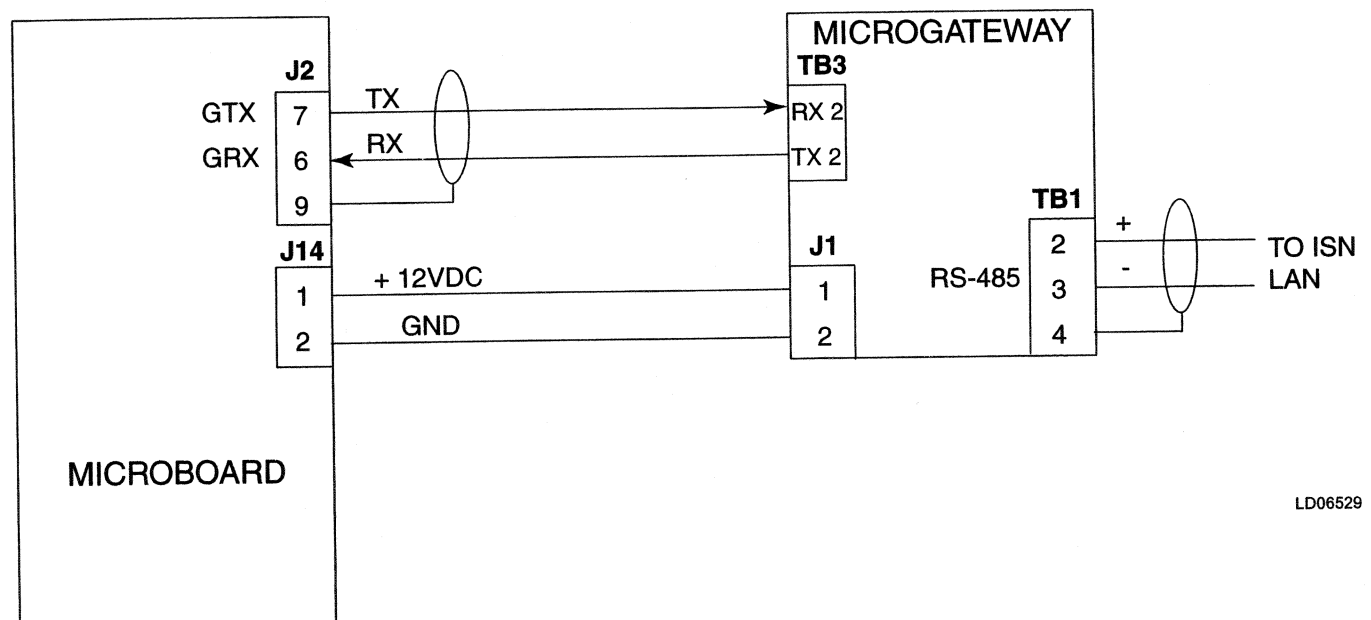

LD06529

FIG. 52 – MICROGATEWAY INTERFACE BLOCK DIAGRAM

SECTION 16

PRESSURE TRANSDUCERS

(REFER TO FIG. 53)

System pressures are sensed by **Pressure Transducers**. The Evaporator, Purge, Condenser, Pump Oil (high side) and Sump Oil (low side) pressures are sensed. There are different transducers used to sense the various system pressures. The actual transducer used is determined by the required pressure range and refrigerant application. The operation of the various transducers is identical. The difference between them is simply the pressure range over which they operate. Each of the different transducers has a different YORK part number. Fig. 53 lists the transducers and the application of each one.

The transducers output a 0.5 to 4.5VDC voltage that is analogous to the pressure applied to the device. These outputs are applied to the Microboard, where this voltage is interpreted as a pressure value in terms of PSIA (pounds per square inch absolute) in English mode or KpaA (Kilo Pascals) in Metric mode. The Program converts the transducer output voltage to a pressure value with the appropriate formula in Fig. 53. The pressures are displayed and used for Chiller control and Safety shutdowns.

The Evaporator and Condenser pressures are converted to Saturation Temperatures per the appropriate refrigerant pressure/temperature conversion table contained in the Program. These Saturation Temperatures are displayed and used for Chiller control.

The outputs of the Sump and Pump oil Pressure transducers are displayed individually as PSIA values. However, the System Oil Pressure is displayed as a differential value in terms of PSID (pounds per square inch differential absolute). This PSID value is arrived at by subtracting the Sump Oil Pressure transducer value from the Pump Oil Pressure transducer value.

The transducers operate from a +5VDC power source. This supply voltage is provided from the Power supply via the Microboard. Each transducer is connected to the Microboard with three wires. Two wires provide the +5VDC supply voltage and Ground (GND) and the remaining wire connects the transducer output to the Microboard. The voltage output of each transducer can be measured with a Voltmeter at the Microboard. Measurement should be made from the transducer output to Ground (GND). For example, the output of the Condenser transducer would be read from Microboard J8-21 (signal) to J8-22 (GND). To convert this output to a pressure, refer to the appropriate formula in Fig. 53. If the pressure is known, the transducer output can be predicted with the appropriate formula in Fig. 53.

If any of the displayed pressures do not appear to be correct, refer to the "Diagnostics and Troubleshooting" section of this book.

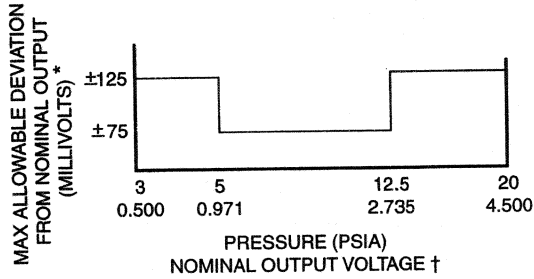

SUMP OIL PRESSURE
YORK PART NO. 025-29148-003

$$V = \frac{P - 0.875}{4.25} \quad P = (4.25 \times V) + 0.875$$

V = VOLTS DC P = PRESSURE (PSIA)

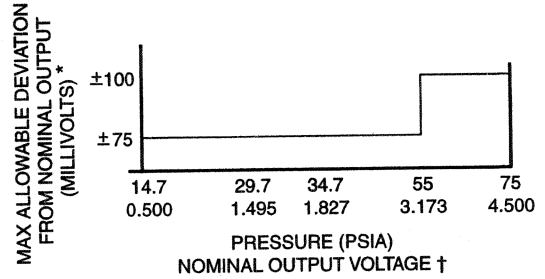

PUMP OIL PRESSURE
YORK PART NO. 025-29148-004

$$V = \frac{P - 7.185}{15.06} \quad P = (15.06 \times V) + 7.185$$

V = VOLTS DC P = PRESSURE (PSIA)

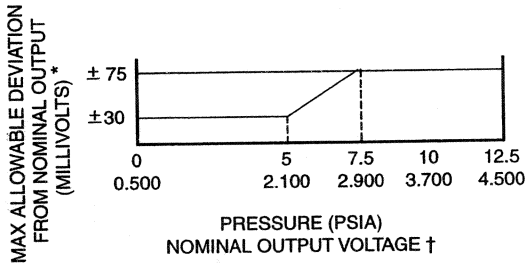

EVAPORATOR PRESSURE
YORK PART NO. 025-29148-102

$$V = \frac{P + 1.5625}{3.125} \quad P = (3.125 \times V) - 1.5625$$

V = VOLTS DC P = PRESSURE (PSIA)

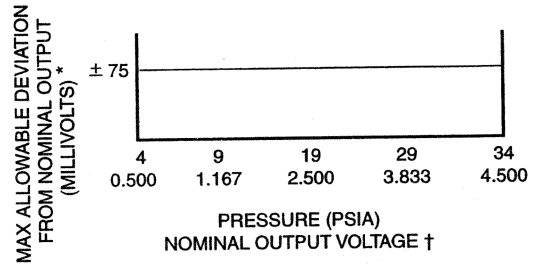

CONDENSER PRESSURE
YORK PART NO. 025-29148-019

$$V = (0.1333 \times P) - 0.333 \quad P = (7.5 \times V) + 0.25$$

V = VOLTS DC P = PRESSURE (PSIA)

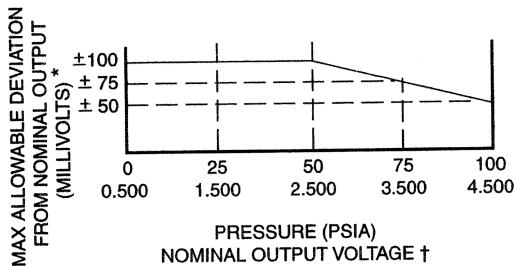

PURGE PRESSURE
YORK PART NO. 025-29148-008

$$V = \frac{P + 12.5}{25.0} \quad P = (25.0 \times V) - 12.5$$

V = VOLTS DC P = PRESSURE (PSIA)

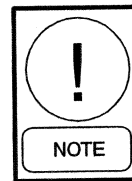

Line Numbers -003, -004 and -008 transducers have NPTF threads. All others have straight threads with neoprene O-rings.

FIG. 53 - PRESSURE TRANSDUCERS

SECTION 17

TEMPERATURE THERMISTORS

(REFER TO FIG. 54 - 59)

System temperatures are sensed by **Thermistors**. There are two different thermistor types used to sense the various system temperatures. Each type has its own YORK part number. Part numbers are listed in YORK Renewal Parts List 160.55-RP1. The Return and Leaving Chilled Liquid, Return and Leaving Condenser Liquid, Drop Leg Refrigerant and Evaporator Temperatures are sensed by 3K Ohm thermistors. The Oil and Compressor Discharge temperatures are sensed by 50K Ohm thermistors.

The 3K Ohm thermistors are defined by the characteristic of being 3000 Ohms at 77°F (25°C). Similarly, the 50K Ohm thermistors are 50,000 Ohms at the same temperature. Both thermistor types vary their resistance as the sensed temperature varies. Both are negative temperature coefficient devices. That is, as the temperature increases, the resistance decreases. As the temperature decreases, the resistance increases.

The thermistors are connected to the Microboard. A +5VDC supply voltage is applied to one side of the thermistor. The other side of the thermistor is connected to Ground through a series resistor on the Microboard, thus forming a voltage divider network. The temperature applied to the thermistor determines the resistance value. The resistance value determines the amount of current that will flow through the thermistor and thus

the voltage drop across it. The Program reads this voltage at the input to the Microboard and converts it to a temperature value.

Each thermistor is connected to the Microboard with two wires. One wire supplies the +5VDC voltage and the other is the output of the thermistor. This output voltage can be measured with a Voltmeter. Measurement should be made from the thermistor output to Ground (Gnd). For example, the Leaving Chilled Liquid Temperature would be read from Microboard J9-20 (output) to Microboard TP1 (Gnd). To convert this voltage to a pressure, refer to the appropriate volts/temp chart as follows:

- Leaving Chilled Liquid Temperature – Fig. 54
- Return Chilled Liquid Temperature – Fig. 55
- Leaving and Return Condenser Liquid Temperature – Fig. 56
- Oil and Discharge Temperature – Fig. 57
- Drop Leg Refrigerant Temperature – Fig. 58
- Evaporator Refrigerant Temperature – Fig. 59

If any of the displayed pressures do not appear to be correct, refer to the “Diagnostics and Troubleshooting” section of this book.

FIG. 54 – LEAVING CHILLED LIQUID TEMPERATURE

Temp (°F)	Temp (°C)	Vin
9.90	-12.28	1.4280
10.00	-12.22	1.4310
10.09	-12.17	1.4341
10.19	-12.12	1.4371
10.29	-12.06	1.4402
10.39	-12.01	1.4432
10.48	-11.96	1.4463
10.58	-11.90	1.4493
10.68	-11.85	1.4423
10.77	-11.80	1.4554
10.87	-11.74	1.4584
10.97	-11.68	1.4615
11.06	-11.63	1.4645
11.16	-11.58	1.4676
11.25	-11.53	1.4706
11.35	-11.47	1.4737
11.45	-11.42	1.4767
11.54	-11.37	1.4798
11.64	-11.31	1.4828
11.73	-11.26	1.4859
11.83	-11.21	1.4889
11.93	-11.15	1.4920
12.02	-11.10	1.4950
12.12	-11.05	1.4981
12.21	-11.00	1.5011
12.31	-10.94	1.5042
12.40	-10.89	1.5072
12.50	-10.83	1.5103
12.59	-10.78	1.5133
12.69	-10.73	1.5164
12.78	-10.68	1.5194
12.88	-10.62	1.5225
12.97	-10.57	1.5255
13.07	-10.52	1.5286
13.16	-10.47	1.5316
13.26	-10.41	1.5347
13.35	-10.36	1.5377
13.45	-10.31	1.5408
13.54	-10.26	1.5438
13.64	-10.20	1.5469
13.73	-10.15	1.5499
13.83	-10.10	1.5530
13.92	-10.05	1.5560
14.01	-10.00	1.5591
14.11	-9.94	1.5621
14.20	-9.89	1.5652
14.29	-9.84	1.5682
14.39	-9.78	1.5713
14.48	-9.73	1.5743
14.57	-9.68	1.5774
14.67	-9.63	1.5804
14.76	-9.58	1.5835
14.85	-9.53	1.5865
14.95	-9.47	1.5896
15.04	-9.42	1.5926

Temp (°F)	Temp (°C)	Vin
15.13	-9.37	1.5957
15.22	-9.32	1.5987
15.32	-9.27	1.6018
15.41	-9.22	1.6048
15.50	-9.17	1.6079
15.60	-9.11	1.6109
15.69	-9.06	1.6140
15.78	-9.01	1.6170
15.87	-8.96	1.6201
15.97	-8.91	1.6231
16.06	-8.86	1.6262
16.15	-8.81	1.6292
16.24	-8.76	1.6322
16.34	-8.70	1.6353
16.43	-8.65	1.6383
16.52	-8.60	1.6414
16.61	-8.55	1.6444
16.70	-8.50	1.6475
16.80	-8.45	1.6505
16.89	-8.40	1.6536
16.98	-8.35	1.6566
17.07	-8.30	1.6597
17.16	-8.25	1.6627
17.26	-8.19	1.6658
17.35	-8.14	1.6688
17.44	-8.09	1.6719
17.53	-8.04	1.6749
17.63	-7.98	1.6780
17.72	-7.93	1.6810
17.81	-7.88	1.6841
17.90	-7.83	1.6871
17.99	-7.78	1.6902
18.08	-7.73	1.6932
18.17	-7.68	1.6963
18.26	-7.63	1.6993
18.35	-7.58	1.7024
18.44	-7.53	1.7054
18.54	-7.48	1.7085
18.63	-7.43	1.7115
18.72	-7.38	1.7146
18.81	-7.33	1.7176
18.90	-7.28	1.7207
18.99	-7.23	1.7237
19.08	-7.18	1.7268
19.17	-7.13	1.7298
19.26	-7.08	1.7329
19.36	-7.02	1.7359
19.45	-6.97	1.7390
19.54	-6.92	1.7420
19.63	-6.87	1.7451
19.72	-6.82	1.7481
19.81	-6.77	1.7512
19.90	-6.72	1.7542
19.99	-6.67	1.7573
20.08	-6.62	1.7603

Temp (°F)	Temp (°C)	Vin
20.17	-6.57	1.7634
20.26	-6.52	1.7664
20.35	-6.47	1.7695
20.44	-6.42	1.7725
20.53	-6.37	1.7756
20.62	-6.32	1.7786
20.71	-6.27	1.7817
20.80	-6.22	1.7847
20.89	-6.17	1.7878
20.98	-6.12	1.7908
21.07	-6.07	1.7939
21.16	-6.02	1.7969
21.25	-5.97	1.8000
21.34	-5.92	1.8030
21.43	-5.87	1.8060
21.52	-5.82	1.8091
21.61	-5.77	1.8121
21.70	-5.72	1.8152
21.79	-5.67	1.8182
21.88	-5.62	1.8213
21.97	-5.57	1.8243
22.06	-5.52	1.8274
22.15	-5.47	1.8304
22.24	-5.42	1.8335
22.33	-5.37	1.8365
22.42	-5.32	1.8396
22.51	-5.27	1.8426
22.60	-5.22	1.8457
22.69	-5.17	1.8487
22.78	-5.12	1.8518
22.87	-5.07	1.8548
22.96	-5.02	1.8579
23.04	-4.98	1.8609
23.13	-4.93	1.8640
23.22	-4.88	1.8670
23.31	-4.83	1.8701
23.40	-4.78	1.8731
23.49	-4.73	1.8762
23.58	-4.68	1.8792
23.67	-4.63	1.8823
23.75	-4.58	1.8853
23.84	-4.53	1.8884
23.93	-4.48	1.8914
24.02	-4.43	1.8945
24.11	-4.38	1.8975
24.20	-4.33	1.9006
24.29	-4.28	1.9036
24.37	-4.24	1.9067
24.46	-4.19	1.9097
24.55	-4.14	1.9128
24.64	-4.09	1.9158
24.73	-4.04	1.9189
24.82	-3.99	1.9219
24.91	-3.94	1.9250
24.99	-3.89	1.9280

17

FIG. 54 – LEAVING CHILLED LIQUID TEMPERATURE (CONT'D.)

Temp (°F)	Temp (°C)	Vin	Temp (°F)	Temp (°C)	Vin	Temp (°F)	Temp (°C)	Vin
25.08	-3.84	1.9311	29.92	-1.16	2.0988	34.73	1.52	2.2665
25.17	-3.79	1.9341	30.01	-1.11	2.1018	34.82	1.57	2.2695
25.26	-3.74	1.9372	30.10	-1.06	2.1049	34.91	1.62	2.2726
25.35	-3.69	1.9402	30.18	-1.01	2.1079	34.99	1.66	2.2756
25.43	-3.65	1.9433	30.27	-0.96	2.1110	35.08	1.71	2.2787
25.52	-3.60	1.9463	30.36	-0.91	2.1140	35.17	1.76	2.2817
25.61	-3.55	1.9494	30.45	-0.86	2.1171	35.26	1.81	2.2848
25.70	-3.50	1.9524	30.53	-0.82	2.1201	35.34	1.86	2.2878
25.79	-3.45	1.9555	30.62	-0.77	2.1232	35.43	1.91	2.2909
25.87	-3.41	1.9585	30.71	-0.72	2.1262	35.52	1.96	2.2939
25.96	-3.36	1.9616	30.79	-0.67	2.1293	35.51	1.95	2.2970
26.05	-3.31	1.9646	30.88	-0.62	2.1323	35.70	2.06	2.3000
26.14	-3.26	1.9677	30.97	-0.57	2.1354	35.78	2.10	2.3031
26.23	-3.21	1.9707	31.06	-0.52	2.1384	35.87	2.15	2.3061
26.31	-3.16	1.9738	31.14	-0.48	2.1415	35.96	2.20	2.3092
26.40	-3.11	1.9768	31.23	-0.43	2.1445	36.05	2.25	2.3122
26.49	-3.06	1.9798	31.32	-0.38	2.1476	36.13	2.29	2.3153
26.58	-3.01	1.9829	31.41	-0.33	2.1506	36.22	2.34	2.3183
26.67	-2.96	1.9859	31.49	-0.28	2.1536	36.31	2.39	2.3214
26.76	-2.91	1.9890	31.58	-0.23	2.1567	36.40	2.44	2.3244
26.84	-2.87	1.9920	31.67	-0.18	2.1597	36.48	2.49	2.3274
26.93	-2.82	1.9951	31.76	-0.13	2.1628	36.57	2.54	2.3305
27.02	-2.77	1.9981	31.84	-0.09	2.1658	36.66	2.59	2.3335
27.11	-2.72	2.0012	31.93	-0.04	2.1689	36.75	2.64	2.3366
27.20	-2.67	2.0042	32.02	0.01	2.1719	36.83	2.68	2.3396
27.28	-2.62	2.0073	32.10	0.06	2.1750	36.92	2.73	2.3427
27.37	-2.57	2.0103	32.19	0.11	2.1780	37.01	2.78	2.3457
27.46	-2.52	2.0134	32.28	0.16	2.1811	37.10	2.83	2.3488
27.55	-2.47	2.0164	32.37	0.21	2.1841	37.18	2.88	2.3518
27.64	-2.42	2.0195	32.45	0.25	2.1872	37.27	2.93	2.3549
27.73	-2.37	2.0225	32.54	0.30	2.1902	37.36	2.98	2.3579
27.81	-2.33	2.0256	32.63	0.35	2.1933	37.45	3.03	2.3610
27.90	-2.28	2.0286	32.72	0.40	2.1963	37.54	3.08	2.3640
27.99	-2.23	2.0317	32.81	0.45	2.1994	37.62	3.12	2.3671
28.08	-2.18	2.0347	32.89	0.49	2.2024	37.71	3.17	2.3701
28.17	-2.13	2.0378	32.98	0.54	2.2055	37.80	3.22	2.3732
28.25	-2.08	2.0408	33.07	0.59	2.2085	37.89	3.27	2.3762
28.34	-2.03	2.0439	33.16	0.64	2.2116	37.98	3.32	2.3793
28.43	-1.98	2.0469	33.24	0.69	2.2146	38.07	3.37	2.3823
28.52	-1.93	2.0500	33.33	0.74	2.2177	38.15	3.42	2.3854
28.61	-1.88	2.0530	33.42	0.79	2.2207	38.24	3.47	2.3884
28.69	-1.84	2.0561	33.51	0.84	2.2238	38.33	3.52	2.3915
28.78	-1.79	2.0591	33.59	0.88	2.2268	38.42	3.57	2.3945
28.87	-1.74	2.0622	33.68	0.93	2.2299	38.51	3.62	2.3976
28.96	-1.69	2.0652	33.77	0.98	2.2329	38.60	3.67	2.4006
29.04	-1.64	2.0683	33.86	1.03	2.2360	38.69	3.72	2.4037
29.13	-1.59	2.0713	33.94	1.08	2.2390	38.77	3.76	2.4067
29.22	-1.54	2.0744	34.03	1.13	2.2421	38.86	3.81	2.4098
29.31	-1.49	2.0774	34.12	1.18	2.2451	38.95	3.86	2.4128
29.39	-1.45	2.0805	34.21	1.23	2.2482	39.04	3.91	2.4159
29.48	-1.40	2.0835	34.29	1.27	2.2512	39.13	3.96	2.4189
29.57	-1.35	2.0866	34.38	1.32	2.2543	39.22	4.01	2.4220
29.66	-1.30	2.0896	34.47	1.37	2.2573	39.30	4.06	2.4250
29.75	-1.25	2.0927	34.56	1.42	2.2604	39.39	4.11	2.4281
29.83	-1.21	2.0957	34.64	1.47	2.2634	39.48	4.16	2.4311

FIG. 54 - LEAVING CHILLED LIQUID TEMPERATURE (CONT'D.)

Temp (°F)	Temp (°C)	Vin	Temp (°F)	Temp (°C)	Vin	Temp (°F)	Temp (°C)	Vin
39.57	4.21	2.4342	44.46	6.92	2.6019	49.48	9.71	2.7696
39.66	4.26	2.4372	44.55	6.97	2.6049	49.57	9.76	2.7726
39.74	4.30	2.4403	44.64	7.02	2.6080	49.66	9.81	2.7757
39.83	4.35	2.4433	44.73	7.07	2.6110	49.75	9.86	2.7787
39.92	4.40	2.4464	44.82	7.12	2.6141	49.84	9.91	2.7818
40.01	4.45	2.4494	44.91	7.17	2.6171	49.94	9.97	2.7848
40.10	4.50	2.4525	45.00	7.22	2.6202	50.03	10.02	2.7879
40.19	4.55	2.4555	45.09	7.27	2.6232	50.12	10.07	2.7909
40.27	4.59	2.4586	45.18	7.32	2.6263	50.22	10.12	2.7940
40.36	4.64	2.4616	45.27	7.37	2.6293	50.31	10.17	2.7970
40.45	4.69	2.4647	45.36	7.42	2.6324	50.40	10.22	2.8001
40.54	4.74	2.4677	45.46	7.48	2.6354	50.50	10.28	2.8031
40.63	4.79	2.4708	45.55	7.53	2.6385	50.59	10.33	2.8062
40.71	4.84	2.4738	45.64	7.58	2.6415	50.68	10.38	2.8092
40.80	4.89	2.4769	45.73	7.63	2.6446	50.78	10.43	2.8123
40.89	4.94	2.4799	45.82	7.68	2.6476	50.87	10.48	2.8153
40.98	4.99	2.4830	45.91	7.73	2.6507	50.96	10.53	2.8184
41.07	5.04	2.4860	46.00	7.78	2.6537	51.06	10.59	2.8214
41.16	5.09	2.4891	46.09	7.83	2.6568	51.15	10.64	2.8245
41.24	5.13	2.4921	46.18	7.88	2.6598	51.24	10.69	2.8275
41.33	5.18	2.4952	46.27	7.93	2.6629	51.34	10.75	2.8306
41.42	5.23	2.4982	46.36	7.98	2.6659	51.43	10.80	2.8336
41.51	5.28	2.5012	46.45	8.03	2.6690	51.52	10.85	2.8367
41.60	5.33	2.5043	46.55	8.08	2.6720	51.62	10.90	2.8397
41.69	5.38	2.5073	46.64	8.13	2.6751	51.71	10.95	2.8428
41.78	5.43	2.5104	46.73	8.18	2.6781	51.80	11.00	2.8458
41.87	5.48	2.5134	46.82	8.23	2.6811	51.90	11.06	2.8458
41.96	5.53	2.5165	46.91	8.28	2.6842	51.99	11.11	2.8519
42.05	5.58	2.5195	47.00	8.33	2.6872	52.09	11.16	2.8549
42.14	5.63	2.5226	47.09	8.38	2.6903	52.18	11.21	2.8580
42.23	5.68	2.5256	47.18	8.43	2.6933	52.28	11.27	2.8610
42.31	5.73	2.5287	47.27	8.48	2.6964	52.37	11.32	2.8641
42.40	5.78	2.5317	47.36	8.53	2.6994	52.46	11.37	2.8671
42.49	5.83	2.5348	47.45	8.58	2.7025	52.56	11.42	2.8702
42.58	5.88	2.5378	47.55	8.64	2.7055	52.65	11.47	2.8732
42.67	5.93	2.5409	47.64	8.69	2.7086	52.75	11.53	2.8763
42.76	5.98	2.5439	47.73	8.74	2.7116	52.84	11.58	2.8793
42.85	6.03	2.5470	47.82	8.79	2.7147	52.94	11.63	2.8824
42.94	6.08	2.5500	47.91	8.84	2.7177	53.03	11.68	2.8854
43.03	6.13	2.5531	48.00	8.89	2.7208	53.13	11.74	2.8885
43.12	6.18	2.5561	48.09	8.94	2.7238	53.22	11.79	2.8915
43.21	6.23	2.5592	48.18	8.99	2.7269	53.32	11.85	2.8946
43.30	6.28	2.5622	48.27	9.04	2.7299	53.41	11.90	2.8976
43.39	6.33	2.5653	48.37	9.10	2.7330	53.51	11.95	2.9007
43.48	6.38	2.5683	48.46	9.15	2.7360	53.60	12.00	2.9037
43.57	6.43	2.5714	48.55	9.20	2.7391	53.70	12.06	2.9068
43.65	6.47	2.5744	48.64	9.25	2.7421	53.79	12.11	2.9098
43.74	6.52	2.5775	48.74	9.30	2.7452	53.89	12.16	2.9129
43.83	6.57	2.5805	48.83	9.35	2.7482	53.98	12.21	2.9159
43.92	6.62	2.5836	48.92	9.40	2.7513	54.08	12.27	2.9190
44.01	6.67	2.5866	49.01	9.45	2.7543	54.17	12.32	2.9220
44.10	6.72	2.5897	49.11	9.51	2.7574	54.27	12.37	2.9251
44.19	6.77	2.5927	49.20	9.56	2.7604	54.36	12.42	2.9281
44.28	6.82	2.5958	49.29	9.61	2.7635	54.46	12.48	2.9312
44.37	6.87	2.5988	49.38	9.66	2.7665	54.55	12.53	2.9342

FIG. 54 – LEAVING CHILLED LIQUID TEMPERATURE (CONT'D.)

Temp (°F)	Temp (°C)	Vin	Temp (°F)	Temp (°C)	Vin	Temp (°F)	Temp (°C)	Vin
54.65	12.58	2.9373	60.05	15.58	3.1050	65.75	18.75	3.2727
54.74	12.63	2.9403	60.15	15.64	3.1080	65.85	18.81	3.2757
54.84	12.69	2.9403	60.25	15.70	3.1111	65.96	18.87	3.2788
54.93	12.74	2.9464	60.36	15.76	3.1141	66.06	18.92	3.2818
55.03	12.80	2.9495	60.46	15.81	3.1172	66.17	18.98	3.2849
55.12	12.85	2.9525	60.56	15.87	3.1202	66.28	19.05	3.2879
55.22	12.90	2.9556	60.66	15.92	3.1233	66.39	19.11	3.2910
55.32	12.96	2.9586	60.76	15.98	3.1263	66.49	19.16	3.2940
55.41	13.01	2.9617	60.86	16.03	3.1294	66.60	19.22	3.2971
55.51	13.06	2.9647	60.96	16.09	3.1324	66.71	19.28	3.3001
55.61	13.12	2.9678	61.06	16.15	3.1355	66.82	19.35	3.3032
55.70	13.17	2.9708	61.17	16.21	3.1385	66.93	19.41	3.3062
55.80	13.22	2.9739	61.27	16.26	3.1416	67.03	19.46	3.3093
55.90	13.28	2.9769	61.37	16.32	3.1446	67.14	19.52	3.3123
56.00	13.33	2.9800	61.47	16.37	3.1477	67.25	19.58	3.3154
56.09	13.38	2.9830	61.57	16.43	3.1507	67.36	19.65	3.3184
56.19	13.44	2.9861	61.67	16.48	3.1538	67.47	19.71	3.3215
56.29	13.50	2.9891	61.78	16.55	3.1568	67.58	19.77	3.3245
56.39	13.55	2.9922	61.88	16.60	3.1599	67.68	19.82	3.3276
56.48	13.60	2.9952	61.98	16.66	3.1629	67.79	19.88	3.3306
56.58	13.66	2.9983	62.08	16.71	3.1660	67.90	19.95	3.3337
56.68	13.71	3.0013	62.18	16.77	3.1690	68.01	20.01	3.3367
56.78	13.77	3.0044	62.28	16.82	3.1721	68.12	20.07	3.3398
56.87	13.82	3.0074	62.39	16.88	3.1751	68.23	20.13	3.3428
56.97	13.87	3.0105	62.49	16.94	3.1782	68.34	20.19	3.3459
57.07	13.93	3.0135	62.59	17.00	3.1812	68.45	20.25	3.3489
57.17	13.98	3.0166	62.69	17.05	3.1843	68.56	20.31	3.3520
57.26	14.03	3.0196	62.80	17.11	3.1873	68.67	20.37	3.3550
57.36	14.09	3.0227	62.90	17.17	3.1904	68.78	20.43	3.3581
57.46	14.15	3.0257	63.01	17.23	3.1934	68.90	20.50	3.3611
57.56	14.20	3.0287	63.11	17.28	3.1965	69.01	20.56	3.3642
57.66	14.26	3.0318	63.22	17.35	3.1995	69.12	20.62	3.3672
57.76	14.31	3.0348	63.32	17.40	3.2025	69.23	20.68	3.3703
57.86	14.37	3.0379	63.43	17.46	3.2056	69.34	20.75	3.3733
57.96	14.42	3.0409	63.53	17.52	3.2086	69.45	20.81	3.3763
58.06	14.48	3.0440	63.63	17.57	3.2117	69.56	20.87	3.3794
58.15	14.53	3.0470	63.74	17.63	3.2147	69.67	20.93	3.3824
58.25	14.58	3.0501	63.84	17.69	3.2178	69.78	20.99	3.3855
58.35	14.64	3.0531	63.95	17.75	3.2208	69.89	21.05	3.3885
58.45	14.70	3.0562	64.05	17.81	3.2239	70.01	21.12	3.3916
58.55	14.75	3.0592	64.16	17.87	3.2269	70.12	21.18	3.3946
58.65	14.81	3.0623	64.26	17.92	3.2300	70.24	21.25	3.3977
58.75	14.86	3.0653	64.37	17.98	3.2330	70.35	21.31	3.4007
58.85	14.92	3.0684	64.47	18.04	3.2361	70.46	21.37	3.4038
58.95	14.97	3.0714	64.58	18.10	3.2391	70.58	21.44	3.4068
59.05	15.03	3.0745	64.68	18.16	3.2422	70.69	21.50	3.4099
59.15	15.08	3.0775	64.79	18.22	3.2452	70.80	21.56	3.4129
59.25	15.14	3.0806	64.90	18.28	3.2483	70.92	21.62	3.4160
59.35	15.20	3.0836	65.00	18.33	3.2513	71.03	21.69	3.4190
59.45	15.25	3.0867	65.11	18.40	3.2544	71.15	21.75	3.4221
59.55	15.31	3.0897	65.21	18.45	3.2574	71.26	21.81	3.4251
59.65	15.36	3.0928	65.32	18.51	3.2605	71.37	21.87	3.4282
59.75	15.42	3.0958	65.43	18.57	3.2635	71.49	21.94	3.4312
59.85	15.47	3.0989	65.53	18.63	3.2666	71.60	22.00	3.4343
59.95	15.53	3.1019	65.64	18.69	3.2696	71.72	22.07	3.4373

FIG. 54 – LEAVING CHILLED LIQUID TEMPERATURE (CONT'D.)

Temp (°F)	Temp (°C)	Vin	Temp (°F)	Temp (°C)	Vin
71.83	22.13	3.4404	78.42	25.79	3.6081
71.95	22.20	3.4434	78.55	25.86	3.6111
72.06	22.26	3.4465	78.67	25.93	3.6142
72.18	22.32	3.4495	78.80	26.00	3.6172
72.29	22.39	3.4526	78.93	26.07	3.6203
72.41	22.45	3.4556	79.05	26.14	3.6233
72.52	22.51	3.4587	79.18	26.21	3.6264
72.64	22.58	3.4617	79.31	26.29	3.6294
72.75	22.64	3.4648	79.44	26.36	3.6325
72.87	22.71	3.4678	79.57	26.43	3.6355
72.98	22.77	3.4709	79.69	26.50	3.6386
73.10	22.84	3.4739	79.82	26.57	3.6416
73.21	22.90	3.4770	79.95	26.64	3.6447
73.33	22.96	3.4800	80.08	26.71	3.6477
73.44	23.02	3.4831	80.20	26.78	3.6508
73.56	23.09	3.4861	80.33	26.85	3.6538
73.68	23.16	3.4892	80.46	26.92	3.6569
73.80	23.22	3.4922	80.59	27.00	3.6599
73.92	23.29	3.4953	80.72	27.07	3.6630
74.04	23.36	3.4983	80.85	27.14	3.6660
74.16	23.42	3.5014	80.98	27.21	3.6691
74.28	23.49	3.5044	81.11	27.29	3.6721
74.40	23.56	3.5075	81.24	27.36	3.6752
74.52	23.62	3.5105	81.37	27.43	3.6782
74.64	23.69	3.5136	81.50	27.50	3.6813
74.75	23.75	3.5166	81.63	27.57	3.6843
74.87	23.82	3.5197	81.76	27.65	3.6874
74.99	23.89	3.5227	81.89	27.72	3.6904
75.11	23.95	3.5258	82.02	27.79	3.6935
75.23	24.02	3.5288	82.15	27.86	3.6965
75.35	24.09	3.5319	82.28	27.94	3.6996
75.47	24.15	3.5349	82.41	28.01	3.7026
75.60	24.22	3.5380			
75.72	24.29	3.5410			
75.84	24.36	3.5441			
75.96	24.42	3.5471			
76.08	24.49	3.5501			
76.20	24.56	3.5532			
76.32	24.62	3.5562			
76.44	24.69	3.5593			
76.57	24.76	3.5623			
76.69	24.83	3.5654			
76.81	24.90	3.5684			
76.93	24.96	3.5715			
77.05	25.03	3.5745			
77.18	25.10	3.5776			
77.30	25.17	3.5806			
77.43	25.24	3.5837			
77.55	25.31	3.5867			
77.68	25.38	3.5898			
77.80	25.45	3.5928			
77.93	25.52	3.5959			
78.05	25.59	3.5989			
78.17	25.65	3.6020			
78.30	25.72	3.6050			

FIG. 55 – RETURN CHILLED LIQUID TEMPERATURE

Temp (°F)	Temp (°C)	Vin	Temp (°F)	Temp (°C)	Vin	Temp (°F)	Temp (°C)	Vin
15.01	-9.44	1.5918	23.03	-4.98	1.8604	30.78	-0.68	2.1289
15.16	-9.36	1.5967	23.17	-4.91	1.8652	30.92	-0.60	2.1338
15.31	-9.27	1.6016	23.31	-4.83	1.8701	31.06	-0.52	2.1387
15.46	-9.19	1.6064	23.45	-4.75	1.8750	31.20	-0.44	2.1436
15.61	-9.11	1.6113	23.60	-4.67	1.8799	31.34	-0.37	2.1484
15.76	-9.02	1.6162	23.74	-4.59	1.8848	31.48	-0.29	2.1533
15.91	-8.94	1.6211	23.88	-4.51	1.8896	31.62	-0.21	2.1582
16.05	-8.86	1.6260	24.02	-4.43	1.8945	31.76	-0.13	2.1631
16.20	-8.78	1.6309	24.16	-4.36	1.8994	31.90	-0.06	2.1680
16.35	-8.70	1.6357	24.31	-4.27	1.9043	32.04	0.02	2.1729
16.50	-8.61	1.6406	24.45	-4.19	1.9092	32.18	0.10	2.1777
16.64	-8.53	1.6455	24.59	-4.12	1.9141	32.32	0.18	2.1826
16.79	-8.45	1.6504	24.73	-4.04	1.9189	32.46	0.26	2.1875
16.94	-8.37	1.6553	24.87	-3.96	1.9238	32.60	0.33	2.1924
17.09	-8.28	1.6602	25.01	-3.88	1.9287	32.74	0.41	2.1973
17.23	-8.21	1.6650	25.16	-3.80	1.9336	32.88	0.49	2.2021
17.38	-8.12	1.6699	25.30	-3.72	1.9385	33.02	0.57	2.2070
17.53	-8.04	1.6748	25.44	-3.64	1.9434	33.16	0.64	2.2119
17.68	-7.96	1.6797	25.58	-3.57	1.9482	33.30	0.72	2.2168
17.82	-7.88	1.6846	25.72	-3.49	1.9531	33.44	0.80	2.2217
17.97	-7.80	1.6895	25.86	-3.41	1.9580	33.59	0.88	2.2266
18.11	-7.72	1.6943	26.00	-3.33	1.9629	33.73	0.96	2.2314
18.26	-7.63	1.6992	26.14	-3.26	1.9678	33.87	1.04	2.2363
18.41	-7.55	1.7041	26.28	-3.18	1.9727	34.01	1.12	2.2412
18.55	-7.47	1.7090	26.42	-3.10	1.9775	34.15	1.19	2.2461
18.70	-7.39	1.7139	26.56	-3.02	1.9824	34.29	1.27	2.2510
18.84	-7.31	1.7188	26.71	-2.94	1.9873	34.43	1.35	2.2559
18.99	-7.23	1.7236	26.85	-2.86	1.9922	34.57	1.43	2.2607
19.13	-7.15	1.7285	26.99	-2.78	1.9971	34.71	1.51	2.2656
19.28	-7.07	1.7334	27.13	-2.71	2.0020	34.85	1.58	2.2705
19.43	-6.98	1.7383	27.27	-2.63	2.0068	34.99	1.66	2.2754
19.57	-6.91	1.7432	27.41	-2.55	2.0117	35.13	1.74	2.2803
19.71	-6.83	1.7480	27.55	-2.47	2.0166	35.27	1.82	2.2852
19.86	-6.74	1.7529	27.70	-2.39	2.0215	35.41	1.89	2.2900
20.00	-6.67	1.7578	27.84	-2.31	2.0264	35.55	1.97	2.2949
20.15	-6.58	1.7627	27.98	-2.23	2.0313	35.69	2.05	2.2998
20.29	-6.51	1.7676	28.12	-2.16	2.0361	35.83	2.13	2.3047
20.44	-6.42	1.7725	28.26	-2.08	2.0410	35.97	2.21	2.3096
20.58	-6.34	1.7773	28.40	-2.00	2.0459	36.11	2.28	2.3145
20.73	-6.26	1.7822	28.54	-1.92	2.5058	36.25	2.36	2.3193
20.87	-6.18	1.7871	28.68	-1.84	2.0557	36.39	2.44	2.3242
21.01	-6.11	1.7920	28.82	-1.77	2.0605	36.53	2.52	2.3291
21.16	-6.02	1.7969	28.96	-1.69	2.0654	36.67	2.59	2.3340
21.30	-5.94	1.8018	29.10	-1.61	2.0703	36.81	2.67	2.3389
21.45	-5.86	1.8066	29.24	-1.53	2.0752	36.95	2.75	2.3438
21.59	-5.78	1.8115	29.38	-1.46	2.0801	37.09	2.83	2.3486
21.73	-5.71	1.8164	29.52	-1.38	2.0850	37.23	2.91	2.3535
21.88	-5.62	1.8213	29.66	-1.30	2.0898	37.37	2.98	2.3584
22.02	-5.54	1.8262	29.80	-1.22	2.0947	37.51	3.06	2.3633
22.17	-5.46	1.8311	29.94	-1.14	2.0996	37.66	3.14	2.3682
22.31	-5.38	1.8359	30.08	-1.07	2.1045	37.80	3.22	2.3730
22.45	-5.31	1.8408	30.22	-0.99	2.1094	37.94	3.30	2.3779
22.60	-5.22	1.8457	30.36	-0.91	2.1143	38.08	3.38	2.3828
22.74	-5.14	1.8506	30.50	-0.83	2.1191	38.22	3.46	2.3877
22.88	-5.07	1.8555	30.64	-0.76	2.1240	38.36	3.53	2.3926

FIG. 55 - RETURN CHILLED LIQUID TEMPERATURE (CONT'D.)

Temp (°F)	Temp (°C)	Vin	Temp (°F)	Temp (°C)	Vin	Temp (°F)	Temp (°C)	Vin
38.51	3.62	2.3975	46.37	7.98	2.6660	54.56	12.53	2.9346
38.65	3.69	2.4023	46.51	8.06	2.6709	54.72	12.62	2.9395
38.79	3.77	2.4072	46.66	8.15	2.6758	54.87	12.71	2.9443
38.93	3.85	2.4121	46.80	8.22	2.6807	55.02	12.79	2.9492
39.07	3.93	2.4170	46.95	8.31	2.6855	55.17	12.87	2.9541
39.21	4.01	2.4219	47.09	8.38	2.6904	55.33	12.96	2.9590
39.35	4.08	2.4268	47.24	8.47	2.6953	55.48	13.05	2.9639
39.50	4.17	2.4316	47.39	8.55	2.7002	55.64	13.13	2.9688
39.64	4.24	2.4365	47.53	8.63	2.7051	55.79	13.22	2.9736
39.78	4.32	2.4414	47.68	8.71	2.7100	55.95	13.31	2.9785
39.92	4.40	2.4463	47.82	8.79	2.7148	56.11	13.40	2.9834
40.06	4.48	2.4512	47.97	8.87	2.7197	56.26	13.48	2.9983
40.20	4.56	2.4561	48.11	8.95	2.7246	56.42	13.57	2.9932
40.34	4.63	2.4609	48.26	9.03	2.7295	56.57	13.65	2.9980
40.48	4.71	2.4658	48.41	9.12	2.7344	56.73	13.74	3.0029
40.62	4.79	2.4707	48.56	9.20	2.7393	56.89	13.83	3.0078
40.76	4.87	2.4756	48.70	9.28	2.7441	57.04	13.91	3.0127
40.91	4.95	2.4805	48.85	9.36	2.7490	57.20	14.00	3.0176
41.05	5.03	2.4854	49.00	9.45	2.7539	57.36	14.09	3.0225
41.19	5.11	2.4902	49.15	9.53	2.7588	57.51	14.17	3.0273
41.33	5.18	2.4951	49.30	9.61	2.7637	57.67	14.26	3.0322
41.48	5.27	2.5000	49.44	9.69	2.7686	57.83	14.35	3.0371
41.62	5.34	2.5049	49.59	9.77	2.7734	57.99	14.44	3.0420
41.76	5.42	2.5098	49.74	9.86	2.7783	58.15	14.53	3.0469
41.90	5.50	2.5146	49.89	9.94	2.7832	58.31	14.62	3.0518
42.05	5.58	2.5195	50.04	10.02	2.7881	58.47	14.71	3.0566
42.19	5.66	2.5244	50.19	10.11	2.7930	58.62	14.79	3.0615
42.33	5.74	2.5293	50.34	10.19	2.7979	58.78	14.88	3.0664
42.48	5.82	2.5342	50.48	10.27	2.8027	58.94	14.97	3.0713
42.62	5.90	2.5391	50.63	10.35	2.8076	59.10	15.06	3.0762
42.76	5.98	2.5439	50.78	10.43	2.8125	59.26	15.15	3.0811
42.90	6.06	2.5488	50.93	10.52	2.8174	59.42	15.23	3.0859
43.05	6.14	2.5537	51.08	10.60	2.8223	59.59	15.33	3.0908
43.19	6.22	2.5586	51.23	10.68	2.8271	59.75	15.42	3.0957
43.33	6.29	2.5635	51.38	10.77	2.8320	59.91	15.51	3.1006
43.48	6.38	2.5684	51.53	10.85	2.8369	60.07	15.60	3.1055
43.62	6.46	2.5732	51.68	10.93	2.8418	60.23	15.68	3.1104
43.76	6.53	2.5781	51.83	11.02	2.8467	60.39	15.77	3.1152
43.91	6.62	2.5830	51.98	11.10	2.8516	60.55	15.86	3.1201
44.05	6.69	2.5879	52.13	11.18	2.8564	60.72	15.96	3.1250
44.19	6.77	2.5928	52.28	11.27	2.8613	60.88	16.05	3.1299
44.34	6.86	2.5977	52.44	11.36	2.8662	61.04	16.13	3.1348
44.48	6.93	2.6025	52.59	11.44	2.8711	61.20	16.22	3.1396
44.62	7.01	2.6074	52.74	11.52	2.8760	61.37	16.32	3.1445
44.77	7.10	2.6123	52.89	11.61	2.8809	61.53	16.41	3.1494
44.91	7.17	2.6172	53.04	11.69	2.8857	61.69	16.50	3.1543
45.06	7.26	2.6221	53.19	11.77	2.8906	61.85	16.58	3.1592
45.20	7.33	2.6270	53.34	11.86	2.8955	62.02	16.68	3.1641
45.35	7.42	2.6318	53.50	11.95	2.9004	62.18	16.77	3.1689
45.49	7.50	2.6367	53.65	12.03	2.9053	62.34	16.86	3.1738
45.64	7.58	2.6416	53.80	12.11	2.9102	62.51	16.95	3.1787
45.79	7.66	2.6465	53.95	12.20	2.0150	62.67	17.04	3.1836
45.93	7.74	2.6514	54.11	12.28	2.9199	62.84	17.13	3.1885
46.08	7.82	2.6563	54.26	12.37	2.9248	63.01	17.23	3.1934
46.22	7.90	2.6611	54.41	12.45	2.9297	63.17	17.32	3.1882

FIG. 55 – RETURN CHILLED LIQUID TEMPERATURE (CONT'D.)

Temp (°F)	Temp (°C)	Vin	Temp (°F)	Temp (°C)	Vin
63.34	17.41	3.2031	73.01	22.79	3.4717
63.51	17.51	3.2080	73.20	22.89	3.4766
63.68	17.60	3.2129	73.38	22.99	3.4814
63.84	17.69	3.2178	73.57	23.10	3.4863
64.01	17.78	3.2227	73.76	23.20	3.4912
64.18	17.88	3.2275	73.95	23.31	3.4961
64.34	17.97	3.2324	74.14	23.41	3.5010
64.51	18.06	3.2373	74.33	23.52	3.5059
64.68	18.16	3.2422	74.53	23.63	3.5107
64.85	18.25	3.2471	74.72	23.74	3.5156
65.02	18.35	3.2520	74.91	23.84	3.5205
65.19	18.44	3.2568	75.10	23.95	3.5254
65.36	18.53	3.2617	75.29	24.05	3.5303
65.53	18.63	3.2666	75.48	24.16	3.5352
65.70	18.72	3.2715	75.68	24.27	3.5400
65.87	18.82	3.2764	75.87	24.37	3.5449
66.04	18.91	3.2813	76.07	24.49	3.5498
66.21	19.01	3.2861	76.26	24.59	3.5547
66.39	19.11	3.2910	76.46	24.70	3.5596
66.56	19.20	3.2959	76.65	24.81	3.5645
66.73	19.30	3.3008	76.84	24.91	3.5693
66.91	19.40	3.3057	77.04	25.02	3.5742
67.08	19.49	3.3105	77.24	25.14	3.5791
67.25	19.58	3.3154	77.44	25.25	3.5840
67.43	19.68	3.3203	77.64	25.36	3.5889
67.60	19.78	3.3252	77.84	25.47	3.5938
67.77	19.87	3.3301	78.04	25.58	3.5986
67.95	19.97	3.3350	78.24	25.69	3.6035
68.12	20.07	3.3398	78.44	25.80	3.6084
68.30	20.17	3.3447	78.64	25.91	3.6133
68.48	20.27	3.3496	78.84	26.02	3.6182
68.66	20.37	3.3545	79.04	26.14	3.6230
68.83	20.46	3.3594	79.25	26.25	3.6279
69.01	20.56	3.3643	79.45	26.36	3.6328
69.19	20.66	3.3691	79.66	26.48	3.6377
69.36	20.76	3.3740	79.86	26.59	3.6426
69.54	20.86	3.3789	80.07	26.71	3.6475
69.72	20.96	3.3838	80.27	26.82	3.6523
69.90	21.06	3.3887	80.48	26.94	3.6572
70.08	21.16	3.3936	80.68	27.05	3.6621
70.26	21.26	3.3984	80.89	27.16	3.6670
70.45	21.36	3.4033	81.10	27.28	3.6719
70.63	21.46	3.4082	81.31	27.40	3.6768
70.81	21.56	3.4131	81.52	27.51	3.6816
70.99	21.66	3.4180	81.72	27.62	3.6865
71.17	21.76	3.4229	81.93	27.74	3.6914
71.36	21.87	3.4277	82.14	27.86	3.6963
71.54	21.97	3.4326	82.35	27.97	3.7012
71.72	22.07	3.4375	82.56	28.09	3.7061
71.91	22.17	3.4424			
72.09	22.27	3.4473			
72.28	22.38	3.4521			
72.46	22.48	3.4570			
72.64	22.58	3.4619			
72.83	22.69	3.4668			

FIG. 56 – RETURN AND LEAVING CONDENSING WATER

Temp (°F)	Temp (°C)	Vin	Temp (°F)	Temp (°C)	Vin	Temp (°F)	Temp (°C)	Vin
40.12	4.51	1.8408	48.39	9.11	2.1094	56.61	13.67	2.3779
40.27	4.59	1.8457	48.54	9.19	2.1143	56.76	13.76	2.3828
40.42	4.68	1.8506	48.69	9.27	2.1191	56.91	13.84	2.3877
40.58	4.77	1.8555	48.84	9.36	2.1240	57.06	13.92	2.3926
40.73	4.85	1.8604	48.99	9.44	2.1289	57.21	14.01	2.3975
40.88	4.93	1.8652	49.14	9.52	2.1338	57.36	14.09	2.4023
41.03	5.02	1.8701	49.29	9.61	2.1387	57.51	14.17	2.4072
41.18	5.10	1.8750	49.44	9.69	2.1436	57.66	14.26	2.4121
41.33	5.18	1.8799	49.59	9.77	2.1484	57.81	14.34	2.4170
41.48	5.27	1.8848	49.74	9.86	2.1533	57.97	14.43	2.4219
41.64	5.36	1.8896	49.89	9.94	2.1582	58.12	14.51	2.4268
41.79	5.44	1.8945	50.03	10.02	2.1631	58.27	14.60	2.4316
41.94	5.52	1.8994	50.18	10.10	2.1680	58.42	14.68	2.4365
42.09	5.61	1.9043	50.33	10.18	2.1729	58.57	14.76	2.4414
42.24	5.69	1.9092	50.48	10.27	2.1777	58.72	14.85	2.4463
42.39	5.77	1.9141	50.63	10.35	2.1826	58.87	14.93	2.4512
42.54	5.86	1.9189	50.78	10.43	2.1875	59.02	15.01	2.4561
42.70	5.94	1.9238	50.93	10.52	2.1924	59.17	15.10	2.4609
42.85	6.03	1.9287	51.08	10.60	2.1973	59.33	15.18	2.4658
43.00	6.11	1.9336	51.23	10.68	2.2021	59.48	15.27	2.4707
43.15	6.19	1.9385	51.38	10.77	2.2070	59.63	15.35	2.4756
43.30	6.28	1.9434	51.53	10.85	2.2119	59.78	15.43	2.4805
43.45	6.36	1.9482	51.68	10.93	2.1268	59.93	15.52	2.4854
43.60	6.44	1.9531	51.83	11.02	2.2217	60.09	15.61	2.4902
43.75	6.53	1.9580	51.97	11.10	2.2266	60.24	15.69	2.4951
43.90	6.61	1.9629	52.12	11.18	2.2314	60.39	15.77	2.5000
44.05	6.69	1.9678	52.27	11.26	2.2363	60.54	15.86	2.5049
44.20	6.78	1.9727	52.42	11.35	2.2412	60.69	15.94	2.5098
44.35	6.86	1.9775	52.57	11.43	2.2461	60.85	16.03	2.5146
44.50	6.95	1.9824	52.72	11.51	2.2510	61.00	16.11	2.5195
44.65	7.03	1.9873	52.87	11.60	2.2559	61.15	16.20	2.5244
44.80	7.11	1.9922	53.02	11.68	2.2607	61.30	16.28	2.5293
44.95	7.20	1.9971	53.17	11.76	2.2656	61.45	16.36	2.5342
45.10	7.28	2.0020	53.32	11.85	2.2705	61.61	16.45	2.5391
45.25	7.36	2.0068	53.47	11.93	2.2754	61.76	16.53	2.5439
45.40	7.45	2.0117	53.62	12.01	2.2803	61.91	16.62	2.5488
45.55	7.53	2.0166	53.77	12.10	2.2852	62.06	16.70	2.5537
45.70	7.61	2.0215	53.92	12.18	2.2900	62.21	16.78	2.5586
45.85	7.70	2.0264	54.07	12.26	2.2949	62.36	16.87	2.5635
46.00	7.78	2.0313	54.21	12.34	2.2998	62.52	16.96	2.5684
46.15	7.86	2.0361	54.36	12.42	2.3047	62.67	17.04	2.5732
46.30	7.95	2.0410	54.51	12.51	2.3096	62.82	17.12	2.5781
46.45	8.03	2.0459	54.66	12.59	2.3145	62.98	17.21	2.5830
46.60	8.11	2.0508	54.81	12.67	2.3193	63.13	17.30	2.5879
46.75	8.20	2.0557	54.96	12.76	2.3242	63.29	17.38	2.5928
46.90	8.28	2.0605	55.11	12.84	2.3291	63.44	17.47	2.5977
47.05	8.36	2.0654	55.26	12.92	2.3340	63.59	17.55	2.6025
47.20	8.45	2.0703	55.41	13.01	2.3389	63.75	17.64	2.6074
47.35	8.53	2.0752	55.56	13.09	2.3438	63.90	17.72	2.6123
47.50	8.61	2.0801	55.71	13.17	2.3486	64.06	17.81	2.6172
47.65	8.70	2.0850	55.86	13.26	2.3535	64.21	17.90	2.6221
47.79	8.77	2.0898	56.01	13.34	2.3584	64.36	17.98	2.6270
47.94	8.86	2.0947	56.16	13.42	2.3633	64.52	18.07	2.6318
48.09	8.94	2.0996	56.31	13.51	2.3682	64.52	18.07	2.6367
48.24	9.02	2.1045	56.46	13.59	2.3730	64.83	18.24	2.6416

17

FIG. 56 – RETURN AND LEAVING CONDENSING WATER (CONT'D)

Temp (°F)	Temp (°C)	Vin	Temp (°F)	Temp (°C)	Vin	Temp (°F)	Temp (°C)	Vin
64.98	18.32	2.6465	73.71	23.17	2.9150	83.04	28.36	3.1836
65.14	18.41	2.6514	73.87	23.26	2.9199	83.22	28.46	3.1885
65.29	18.50	2.6563	74.04	23.36	2.9248	83.39	28.55	3.1934
65.45	18.58	2.6611	74.20	23.45	2.9297	83.57	28.65	3.1982
65.60	18.67	2.6660	74.37	23.54	2.9346	83.75	28.75	3.2031
65.76	18.76	2.6709	74.53	23.63	2.9395	83.93	28.85	3.2080
65.91	18.84	2.6758	74.70	23.72	2.9443	84.10	28.95	3.2129
66.07	18.93	2.6807	74.86	23.81	2.9492	84.28	29.05	3.2178
66.22	19.01	2.6855	75.03	23.91	2.9541	84.46	29.15	3.2227
66.38	19.10	2.6904	75.19	24.00	2.9590	84.65	29.25	3.2275
66.54	19.19	2.6953	75.36	24.09	2.9639	84.83	29.35	3.2324
66.69	19.27	2.7002	75.52	24.18	2.9688	85.01	29.45	3.2373
66.85	19.36	2.7051	75.69	24.27	2.9736	85.19	29.55	3.2422
66.00	18.89	2.7100	75.85	24.36	2.9785	85.37	29.65	3.2471
67.16	19.53	2.7148	76.02	24.46	2.9834	85.55	29.75	3.2520
67.32	19.62	2.7197	76.19	24.55	2.9883	85.73	29.85	3.2568
67.47	19.71	2.7246	76.35	24.64	2.9932	85.92	29.96	3.2617
67.63	19.80	2.7295	76.52	24.74	2.9980	86.10	30.06	3.2666
67.78	19.88	2.7344	76.69	24.83	3.0029	86.28	30.16	3.2715
67.94	19.97	2.7393	76.85	24.92	3.0078	86.47	30.26	3.2764
68.10	20.06	2.7441	77.02	25.01	3.0127	86.65	30.36	3.2813
68.26	20.15	2.7490	77.19	25.11	3.0176	86.84	30.47	3.2861
68.41	20.23	2.7539	77.36	25.20	3.0225	87.02	30.57	3.2910
68.57	20.32	2.7588	77.53	25.30	3.0273	87.21	30.67	3.2959
68.73	20.41	2.7637	77.70	25.39	3.0322	87.39	30.77	3.3008
68.89	20.50	2.7686	77.86	25.48	3.0371	87.58	30.88	3.3057
69.05	20.58	2.7734	78.03	25.57	3.0420	87.76	30.98	3.3105
69.21	20.67	2.7783	78.20	25.67	3.0469	87.95	31.09	3.3154
69.36	20.76	2.7832	78.37	25.76	3.0518	88.13	31.19	3.3203
69.52	20.85	2.7881	78.54	25.86	3.0566	88.32	31.29	3.3252
69.68	20.94	2.7930	78.71	25.95	3.0615	88.51	31.40	3.3301
69.84	21.02	2.7979	78.88	26.05	3.0664	88.70	31.50	3.3350
70.00	21.11	2.8027	79.05	26.14	3.0713	88.88	31.60	3.3398
70.16	21.20	2.8076	79.22	26.24	3.0762	89.07	31.71	3.3447
70.32	21.29	2.8125	79.40	26.34	3.0811	89.26	31.81	3.3496
70.48	21.38	2.8174	79.57	26.43	3.0859	89.44	31.91	3.3545
70.64	21.47	2.8223	79.74	26.52	3.0908	89.63	32.02	3.3594
70.80	21.56	2.8271	79.91	26.62	3.0957	89.82	32.12	3.3643
70.96	21.65	2.8320	80.08	26.71	3.1006	90.01	32.23	3.3691
71.12	21.74	2.8369	80.26	26.81	3.1055	90.20	32.34	3.3740
71.28	21.82	2.8418	80.43	26.91	3.1104	90.39	32.44	3.3789
71.44	21.91	2.8467	80.60	27.00	3.1152	90.59	32.55	3.3838
71.61	22.01	2.8516	80.77	27.10	3.1201	90.78	32.66	3.3887
71.77	22.10	2.8564	80.95	27.20	3.1250	90.97	32.76	3.3936
71.93	22.19	2.8613	81.12	27.29	3.1299	91.16	32.87	3.3984
72.09	22.27	2.8662	81.29	27.39	3.1348	91.35	32.97	3.4033
72.25	22.36	2.8711	81.47	27.49	3.1396	91.54	33.08	3.4082
72.41	22.45	2.8760	81.64	27.58	3.1445	91.74	33.19	3.4131
72.57	22.54	2.8809	81.81	27.67	3.1494	91.93	33.30	3.4180
72.73	22.63	2.8857	81.99	27.77	3.1543	92.13	33.41	3.4229
72.89	22.72	2.8906	82.16	27.87	3.1592	92.32	33.51	3.4277
73.05	22.81	2.8955	82.33	27.96	3.1641	92.52	33.62	3.4326
73.22	22.90	2.9004	82.51	28.06	3.1689	92.72	33.74	3.4375
73.38	22.99	2.9053	82.69	28.16	3.1738	92.91	33.84	3.4424
73.54	23.08	2.9102	82.86	28.26	3.1787	93.11	33.95	3.4473

FIG. 56 – RETURN AND LEAVING CONDENSING WATER (CONT'D)

Temp (°F)	Temp (°C)	Vin	Temp (°F)	Temp (°C)	Vin
93.31	34.06	3.4521	105.04	40.58	3.7207
93.51	34.17	3.4570	105.27	40.71	3.7256
93.70	34.28	3.4619	105.50	40.84	3.7305
93.90	34.39	3.4668	105.73	40.96	3.7354
94.10	34.50	3.4717	105.96	41.09	3.7402
94.30	34.61	3.4766	106.20	41.23	3.7451
94.50	34.73	3.4814	106.44	41.36	3.7500
94.70	34.84	3.4863	106.67	41.49	3.7549
94.90	34.95	3.4912	106.91	41.62	3.7598
95.11	35.06	3.4961	107.14	41.75	3.7646
95.31	35.18	3.5010	107.38	41.88	3.7695
95.52	35.29	3.5059	107.62	42.01	3.7744
95.72	35.40	3.5107	107.86	42.15	3.7793
95.93	35.52	3.5156	108.11	42.29	3.7842
96.13	35.63	3.5205	108.35	42.42	3.7891
96.34	35.75	3.5254	108.59	42.55	3.7939
96.54	35.86	3.5303	108.84	42.69	3.7988
96.75	35.98	3.5352	109.08	42.83	3.8037
96.96	36.09	3.5400	109.32	42.96	3.8086
97.17	36.21	3.5449	109.57	43.10	3.8135
97.38	36.33	3.5498	109.82	43.24	3.8184
97.59	36.44	3.5547	110.06	43.37	3.8232
97.80	36.56	3.5596	110.31	43.51	3.8281
98.01	36.68	3.5645	110.56	43.65	3.8330
98.22	36.79	3.5693	110.81	43.79	3.8379
98.43	36.91	3.5742	111.05	43.92	3.8328
98.64	37.03	3.5791	111.31	44.06	3.8477
98.86	37.15	3.5840	111.36	44.09	3.8525
99.07	37.26	3.5889	111.82	44.35	3.8574
99.29	37.39	3.5938	112.08	44.49	3.8623
99.50	37.50	3.5986	112.34	44.64	3.8672
99.71	37.62	3.6035	112.59	44.78	3.8721
99.93	37.74	3.6084	112.85	44.92	3.8770
100.14	37.86	3.6133	113.11	45.06	3.8818
100.36	37.98	3.6182	113.37	45.21	3.8867
100.58	38.10	3.6230	113.63	45.35	3.8916
100.79	38.22	3.6279	113.88	45.49	3.8965
101.01	38.34	3.6328	114.14	45.64	3.9014
101.23	38.46	3.6377			
101.45	38.59	3.6426			
101.67	38.71	3.6475			
101.89	38.83	3.6523			
102.11	38.95	3.6572			
102.33	39.08	3.6621			
102.55	39.20	3.6670			
102.78	39.33	3.6719			
103.00	39.45	3.6768			
103.22	39.57	3.6816			
103.45	39.70	3.6865			
103.67	39.82	3.6914			
103.89	39.94	3.6963			
104.12	40.07	3.7012			
104.35	40.20	3.7061			
104.58	40.33	3.7109			
104.81	40.45	3.7158			

FIG. 57 – OIL AND DISCHARGE TEMPERATURE

Temp (°F)	Temp (°C)	Vin	Temp (°F)	Temp (°C)	Vin	Temp (°F)	Temp (°C)	Vin
31.99	-0.01	0.2637	58.43	14.68	0.5322	75.98	24.44	0.8008
32.63	0.35	0.2686	58.81	14.90	0.5371	76.25	24.59	0.8057
33.27	0.71	0.2734	59.18	15.10	0.5420	76.53	24.74	0.8105
33.90	1.06	0.2783	59.54	15.30	0.5469	76.81	24.90	0.8154
34.51	1.39	0.2832	59.90	15.50	0.5518	77.09	25.05	0.8203
35.12	1.73	0.2881	60.26	15.70	0.5566	77.36	25.20	0.8252
35.73	2.07	0.2930	60.63	15.91	0.5615	77.63	25.35	0.8301
36.32	2.40	0.2979	60.98	16.10	0.5664	77.90	25.50	0.8350
36.91	2.73	0.3027	61.33	16.30	0.5713	78.17	25.65	0.8398
37.49	3.05	0.3076	61.69	16.50	0.5762	78.44	25.80	0.8447
38.05	3.36	0.3125	62.04	16.69	0.5811	78.71	25.95	0.8496
38.61	3.67	0.3174	62.39	16.88	0.5859	78.98	26.10	0.8545
39.18	3.99	0.3223	62.73	17.07	0.5908	79.24	26.25	0.8594
39.72	4.29	0.3271	63.07	17.26	0.5957	79.50	26.39	0.8643
40.26	4.59	0.3320	63.41	17.45	0.6006	79.77	26.54	0.8691
40.80	4.89	0.3369	63.75	17.64	0.6055	80.03	26.69	0.8740
41.33	5.18	0.3418	64.09	17.83	0.6104	80.30	26.84	0.8789
41.85	5.47	0.3467	64.43	18.02	0.6152	80.56	26.98	0.8838
42.37	5.76	0.3516	64.76	18.20	0.6201	80.82	27.12	0.8887
42.89	6.05	0.3564	65.09	18.38	0.6250	81.08	27.27	0.8936
43.39	6.33	0.3613	65.42	18.57	0.6299	81.33	27.41	0.8984
43.89	6.61	0.3662	65.75	18.75	0.6348	81.59	27.55	0.9033
44.39	6.88	0.3711	66.08	18.93	0.6396	81.85	27.70	0.9082
44.88	7.16	0.3760	66.40	19.11	0.6445	82.11	27.84	0.9131
45.36	7.42	0.3809	66.72	19.29	0.6494	82.37	27.99	0.9180
45.84	7.69	0.3857	67.04	19.47	0.6543	82.62	28.12	0.9229
46.32	7.96	0.3906	67.36	19.65	0.6592	82.87	28.26	0.9277
46.79	8.22	0.3955	67.68	19.82	0.6641	83.12	28.40	0.9326
47.25	8.47	0.4004	68.00	20.00	0.6689	83.37	28.54	0.9375
47.72	8.73	0.4053	68.31	20.17	0.6738	83.62	28.68	0.9424
48.18	8.99	0.4102	68.62	20.35	0.6787	83.88	28.82	0.9473
48.63	9.24	0.4150	68.93	20.52	0.6836	84.13	28.96	0.9521
49.07	9.48	0.4199	69.24	20.69	0.6885	84.38	29.10	0.9570
49.52	9.73	0.4248	69.55	20.86	0.6934	84.62	29.24	0.9619
49.97	9.98	0.4297	69.86	21.04	0.6982	84.87	29.37	0.9668
50.40	10.22	0.4346	70.17	21.21	0.7031	85.11	29.51	0.9717
50.83	10.46	0.4395	70.47	21.37	0.7080	85.36	29.65	0.9766
51.26	10.70	0.4443	70.77	21.54	0.7129	85.61	29.79	0.9814
51.69	10.94	0.4492	71.07	21.71	0.7178	85.85	29.92	0.9863
52.11	11.17	0.4541	71.37	21.87	0.7227	86.10	30.06	0.9912
52.53	11.41	0.4590	71.67	22.04	0.7275	86.34	30.19	0.9961
52.94	11.63	0.4639	71.96	22.20	0.7324	86.58	30.32	1.0010
53.36	11.87	0.4688	72.26	22.37	0.7373	86.82	30.46	1.0059
53.77	12.10	0.4736	72.55	22.53	0.7422	87.06	30.59	1.0107
54.17	12.32	0.4785	72.84	22.69	0.7471	87.30	30.72	1.0156
54.57	12.54	0.4834	73.14	22.86	0.7520	87.54	30.86	1.0205
54.97	12.76	0.4883	73.43	23.02	0.7568	87.78	30.99	1.0254
55.37	12.98	0.4932	73.72	23.18	0.7617	88.02	31.12	1.0303
55.76	13.20	0.4980	74.00	23.34	0.7666	88.25	31.25	1.0352
56.15	13.42	0.5029	74.29	23.50	0.7715	88.49	31.39	1.0400
56.54	13.63	0.5078	74.57	23.65	0.7764	88.72	31.51	1.0449
56.92	13.85	0.5127	74.86	23.81	0.7813	88.96	31.65	1.0498
57.31	14.06	0.5176	75.14	23.97	0.7861	89.20	31.78	1.0547
57.68	14.27	0.5225	75.42	24.12	0.7910	89.43	31.91	1.0596
58.06	14.48	0.5273	75.70	24.28	0.7959	89.67	32.04	1.0645

FIG. 57 - OIL AND DISCHARGE TEMPERATURE (CONT'D.)

Temp (°F)	Temp (°C)	Vin	Temp (°F)	Temp (°C)	Vin	Temp (°F)	Temp (°C)	Vin
89.90	32.17	1.0693	101.92	38.85	1.3379	112.86	44.93	1.6064
90.13	32.30	1.0742	102.13	38.96	1.3428	113.06	45.04	1.6113
90.36	32.42	1.0791	102.33	39.08	1.3477	113.25	45.14	1.6162
90.59	32.55	1.0840	102.54	39.19	1.3525	113.44	45.25	1.6211
90.82	32.68	1.0889	102.74	39.30	1.3574	113.63	45.35	1.6260
91.05	32.81	1.0938	102.95	39.42	1.3623	113.82	45.46	1.6309
91.28	32.94	1.0986	103.15	39.53	1.3672	114.01	45.56	1.6357
91.51	33.06	1.1035	103.36	39.65	1.3721	114.20	45.67	1.6406
91.74	33.19	1.1084	103.56	39.76	1.3770	114.40	45.78	1.6455
91.96	33.31	1.1133	103.77	39.88	1.3818	114.59	45.89	1.6504
92.19	33.44	1.1182	103.97	39.99	1.3867	114.78	45.99	1.6553
92.42	33.57	1.1230	104.18	40.10	1.3916	114.97	46.10	1.6602
92.64	33.69	1.1279	104.38	40.21	1.3965	115.16	46.20	1.6650
92.87	33.82	1.1328	104.58	40.33	1.4014	115.35	46.31	1.6699
93.10	33.95	1.1377	104.78	40.44	1.4063	115.54	46.41	1.6748
93.32	34.07	1.1426	104.99	40.55	1.4111	115.73	46.52	1.6797
93.54	34.19	1.1475	105.19	40.66	1.4160	115.92	46.63	1.6846
93.77	34.32	1.1523	105.39	40.78	1.4209	116.11	46.73	1.6895
93.99	34.44	1.1572	105.59	40.89	1.4258	116.30	46.84	1.6943
94.21	34.56	1.1621	105.80	41.00	1.4307	116.49	46.94	1.6992
94.43	34.69	1.1670	105.99	41.11	1.4355	116.67	47.04	1.7041
94.65	34.81	1.1719	106.19	41.22	1.4404	116.86	47.15	1.7090
94.88	34.94	1.1768	106.39	41.33	1.4453	117.05	47.25	1.7139
95.10	35.06	1.1816	106.59	41.44	1.4502	117.24	47.36	1.7188
95.32	35.18	1.1865	106.79	41.55	1.4551	117.43	47.46	1.7236
95.53	35.30	1.1914	106.99	41.66	1.4600	117.62	47.57	1.7285
95.75	35.42	1.1963	107.19	41.78	1.4648	117.80	47.67	1.7334
95.97	35.54	1.2012	107.39	41.89	1.4697	117.99	47.78	1.7383
96.19	35.66	1.2061	107.59	42.00	1.4746	118.18	47.88	1.7432
96.41	35.79	1.2109	107.79	42.11	1.4795	118.37	47.99	1.7480
96.63	35.91	1.2158	107.99	42.22	1.4844	118.56	48.09	1.7529
96.84	36.03	1.2207	108.18	42.33	1.4893	118.74	48.19	1.7578
97.06	36.15	1.2256	108.38	42.44	1.4941	118.93	48.30	1.7627
97.27	36.26	1.2305	108.58	42.55	1.4990	119.12	48.40	1.7676
97.49	36.39	1.2354	108.78	42.66	1.5039	119.31	48.51	1.7725
97.70	36.50	1.2402	108.97	42.76	1.5088	119.49	48.61	1.7773
97.92	36.63	1.2451	109.17	42.88	1.5137	119.68	48.72	1.7822
98.13	36.74	1.2500	109.37	42.99	1.5186	119.87	48.82	1.7871
98.35	36.86	1.2549	109.56	43.09	1.5234	120.05	48.92	1.7920
98.56	36.98	1.2598	109.76	43.20	1.5283	120.24	49.03	1.7969
98.77	37.10	1.2646	109.95	43.31	1.5332	120.43	49.13	1.8018
98.98	37.21	1.2695	110.15	43.42	1.5381	120.61	49.23	1.8066
99.20	37.34	1.2744	110.34	43.53	1.5430	120.80	49.34	1.8115
99.41	37.45	1.2793	110.54	43.64	1.5479	120.98	49.44	1.8164
99.62	37.57	1.2842	110.73	43.74	1.5527	121.17	49.54	1.8213
99.83	37.69	1.2891	110.93	43.85	1.5576	121.35	49.64	1.8262
100.04	37.80	1.2939	111.12	43.96	1.5625	121.54	49.75	1.8311
100.25	37.92	1.2988	111.32	44.07	1.5674	121.72	49.85	1.8359
100.46	38.04	1.3037	111.51	44.18	1.5723	121.91	49.95	1.8408
100.67	38.15	1.3086	111.70	44.28	1.5771	122.10	50.06	1.8457
100.88	38.27	1.3135	111.90	44.39	1.5820	122.28	50.16	1.8506
101.09	38.39	1.3184	112.09	44.50	1.5869	122.47	50.27	1.8555
101.29	38.50	1.3232	112.28	44.60	1.5918	122.65	50.37	1.8604
101.50	38.61	1.3281	112.48	44.71	1.5967	122.84	50.47	1.8652
101.71	38.73	1.3330	112.67	44.82	1.6016	123.02	50.57	1.8701

FIG. 57 – OIL AND DISCHARGE TEMPERATURE (CONT'D.)

Temp (°F)	Temp (°C)	Vin	Temp (°F)	Temp (°C)	Vin	Temp (°F)	Temp (°C)	Vin
123.21	50.68	1.8750	133.27	56.27	2.1436	143.32	61.85	2.4121
123.39	50.78	1.8799	133.46	56.37	2.1484	143.51	61.95	2.4170
123.58	50.88	1.8848	133.64	56.47	2.1533	143.69	62.05	2.4219
123.76	50.98	1.8896	133.82	56.57	2.1582	143.87	62.15	2.4268
123.94	51.08	1.8945	134.00	56.67	2.1631	144.06	62.26	2.4316
124.13	51.19	1.8994	134.18	56.77	2.1680	144.24	62.36	2.4365
124.31	51.29	1.9043	134.37	56.88	2.1729	144.43	62.47	2.4414
124.50	51.39	1.9092	134.55	56.98	2.1777	144.61	62.57	2.4463
124.68	51.49	1.9141	134.73	57.08	2.1826	144.80	62.67	2.4512
124.86	51.59	1.9189	134.91	57.18	2.1875	144.98	62.77	2.4561
125.05	51.70	1.9238	135.09	57.28	2.1924	145.17	62.88	2.4609
125.23	51.80	1.9287	135.28	57.38	2.1973	145.35	62.98	2.4658
125.42	51.90	1.9336	135.46	57.48	2.2021	145.54	63.08	2.4707
125.60	52.00	1.9385	135.64	57.58	2.2070	145.72	63.18	2.4756
125.78	52.10	1.9434	135.82	57.68	2.2119	145.91	63.29	2.4805
125.97	52.21	1.9482	136.01	57.79	2.2168	146.09	63.39	2.4854
126.15	52.31	1.9531	136.19	57.89	2.2217	146.28	63.49	2.4902
126.33	52.41	1.9580	136.37	57.99	2.2266	146.46	63.59	2.4951
126.52	52.52	1.9629	136.55	58.09	2.2314	146.65	63.70	2.5000
126.70	52.62	1.9678	136.73	58.19	2.2363	146.84	63.81	2.5049
126.88	52.72	1.9727	136.92	58.29	2.2412	147.02	63.91	2.5098
127.07	52.82	1.9775	137.10	58.39	2.2461	147.21	64.01	2.5146
127.25	52.92	1.9824	137.28	58.49	2.2510	147.39	64.11	2.5195
127.43	53.02	1.9873	137.46	58.59	2.2559	147.58	64.22	2.5244
127.62	53.13	1.9922	137.65	58.70	2.2607	147.77	64.32	2.5293
127.80	53.23	1.9971	137.83	58.80	2.2656	147.95	64.42	2.5342
127.98	53.33	2.0020	138.01	58.90	2.2705	148.14	64.53	2.5391
128.17	53.43	2.0068	138.19	59.00	2.2754	148.32	64.63	2.5439
128.35	53.53	2.0117	138.37	59.10	2.2803	148.51	64.73	2.5488
128.53	53.63	2.0166	138.56	59.20	2.2852	148.70	64.84	2.5537
128.71	53.73	2.0215	138.74	59.30	2.2900	148.88	64.94	2.5586
128.90	53.84	2.0264	138.92	59.40	2.2949	149.07	65.04	2.5635
129.08	53.94	2.0313	139.11	59.51	2.2998	149.26	65.15	2.5684
129.26	54.04	2.0361	139.29	59.61	2.3047	149.45	65.26	2.5732
129.44	54.14	2.0410	139.47	59.71	2.3096	149.63	65.36	2.5781
129.63	54.24	2.0459	139.65	59.81	2.3145	149.82	65.46	2.5830
129.81	54.34	2.0508	139.84	59.92	2.3193	150.01	65.57	2.5879
129.99	54.44	2.0557	140.02	60.02	2.3242	150.20	65.67	2.5928
130.17	54.54	2.0605	140.20	60.12	2.3291	150.38	65.77	2.5977
130.36	54.65	2.0654	140.39	60.22	2.3340	150.57	65.88	2.6025
130.54	54.75	2.0703	140.57	60.32	2.3389	150.76	65.98	2.6074
130.72	54.85	2.0752	140.75	60.42	2.3438	150.95	66.09	2.6123
130.90	54.95	2.0801	140.94	60.53	2.3486	151.14	66.19	2.6172
131.09	55.05	2.0850	141.12	60.63	2.3535	151.33	66.30	2.6221
131.27	55.15	2.0898	141.30	60.73	2.3584	151.51	66.40	2.6270
131.45	55.25	2.0947	141.49	60.83	2.3633	151.70	66.51	2.6318
131.63	55.35	2.0996	141.67	60.93	2.3682	151.89	66.61	2.6367
131.82	55.46	2.1045	141.85	61.03	2.3730	152.08	66.72	2.6416
132.00	55.56	2.1094	142.04	61.14	2.3779	152.27	66.82	2.6465
132.18	55.66	2.1143	142.22	61.24	2.3828	152.46	66.93	2.6514
132.36	55.76	2.1191	142.40	61.34	2.3877	152.65	67.03	2.6563
132.54	55.86	2.1240	142.59	61.44	2.3926	152.84	67.14	2.6611
132.73	55.97	2.1289	142.77	61.54	2.3975	153.03	67.24	2.6660
132.91	56.07	2.1338	142.95	61.64	2.4023	153.22	67.35	2.6709
133.09	56.17	2.1387	143.14	61.75	2.4072	153.41	67.46	2.6758

FIG. 57 - OIL AND DISCHARGE TEMPERATURE (CONT'D.)

Temp (°F)	Temp (°C)	Vin	Temp (°F)	Temp (°C)	Vin	Temp (°F)	Temp (°C)	Vin
153.60	67.56	2.6807	164.36	73.54	2.9492	175.92	79.96	3.2178
153.79	67.67	2.6855	164.56	73.65	2.9541	176.14	80.08	3.2227
153.98	67.77	2.6904	164.76	73.76	2.9590	176.36	80.21	3.2275
154.17	67.88	2.6953	164.96	73.87	2.9639	176.58	80.33	3.2324
154.36	67.98	2.7002	165.17	73.99	2.9688	176.80	80.45	3.2373
154.55	68.09	2.7051	165.37	74.10	2.9736	177.02	80.57	3.2422
154.74	68.19	2.7100	165.57	74.21	2.9785	177.25	80.70	3.2471
154.94	68.31	2.7148	165.78	74.33	2.9834	177.47	80.82	3.2520
155.13	68.41	2.7197	165.98	74.44	2.9883	177.69	80.95	3.2568
155.32	68.52	2.7246	166.19	74.56	2.9932	177.91	81.07	3.2617
155.51	68.62	2.7295	166.39	74.67	2.9980	178.14	81.20	3.2666
155.70	68.73	2.7344	166.60	74.78	3.0029	178.36	81.32	3.2715
155.90	68.84	2.7393	166.80	74.89	3.0078	178.59	81.45	3.2764
156.09	68.94	2.7441	167.00	75.01	3.0127	178.81	81.57	3.2813
156.28	69.05	2.7490	167.21	75.12	3.0176	179.04	81.70	3.2861
156.47	69.16	2.7539	167.42	75.24	3.0225	179.26	81.82	3.2910
156.67	69.27	2.7588	167.62	75.35	3.0273	179.49	81.95	3.2959
156.86	69.37	2.7637	167.83	75.47	3.0322	179.72	82.07	3.3008
157.05	69.48	2.7686	168.04	75.58	3.0371	179.94	82.20	3.3057
157.25	69.59	2.7734	168.24	75.69	3.0420	180.17	82.32	3.3105
157.44	69.69	2.7783	168.45	75.81	3.0469	180.40	82.45	3.3154
157.64	69.81	2.7832	168.66	75.93	3.0518	180.63	82.58	3.3203
157.83	69.91	2.7881	168.87	76.04	3.0566	180.86	82.71	3.3252
158.02	70.02	2.7930	169.07	76.16	3.0615	181.09	82.83	3.3301
158.22	70.13	2.7979	169.28	76.27	3.0664	181.32	82.96	3.3350
158.41	70.23	2.8027	169.49	76.39	3.0713	181.55	83.09	3.3398
158.61	70.34	2.8076	169.70	76.51	3.0762	181.78	83.22	3.3447
158.80	70.45	2.8125	169.91	76.62	3.0811	182.01	83.35	3.3496
159.00	70.56	2.8174	170.12	76.74	3.0859	182.24	83.47	3.3545
159.19	70.67	2.8223	170.33	76.86	3.0908	182.48	83.61	3.3594
159.39	70.78	2.8271	170.54	76.97	3.0957	182.71	83.73	3.3643
159.59	70.89	2.8320	170.75	77.09	3.1006	182.94	83.86	3.3691
159.78	70.99	2.8369	170.96	77.21	3.1055	183.17	83.99	3.3740
159.98	71.11	2.8418	171.18	77.33	3.1104	183.41	84.12	3.3789
160.18	71.22	2.8467	171.39	77.45	3.1152	183.65	84.26	3.3838
160.37	71.32	2.8516	171.60	77.56	3.1201	183.88	84.38	3.3887
160.57	71.43	2.8564	171.81	77.68	3.1250	184.12	84.52	3.3936
160.77	71.54	2.8613	172.02	77.80	3.1299	184.36	84.65	3.3984
160.97	71.66	2.8662	172.24	77.92	3.1348	184.59	84.78	3.4033
161.16	71.76	2.8711	172.45	78.03	3.1396	184.83	84.91	3.4082
161.36	71.87	2.8760	172.66	78.15	3.1445	185.07	85.05	3.4131
161.56	71.98	2.8809	172.88	78.27	3.1494	185.31	85.18	3.4180
161.76	72.09	2.8857	173.10	78.40	3.1543	185.55	85.31	3.4229
161.96	72.21	2.8906	173.31	78.51	3.1592	185.79	85.45	3.4277
162.15	72.31	2.8955	173.53	78.63	3.1641	186.03	85.58	3.4326
162.35	72.42	2.9004	173.74	78.75	3.1689	186.27	85.71	3.4375
162.55	72.53	2.9053	173.96	78.87	3.1738	186.51	85.85	3.4424
162.75	72.64	2.9102	174.17	78.99	3.1787	186.75	85.98	3.4473
162.95	72.76	2.9150	174.39	79.11	3.1836	186.99	86.11	3.4521
163.15	72.87	2.9199	174.61	79.23	3.1885	187.24	86.25	3.4570
163.35	72.98	2.9248	174.83	79.36	3.1934	187.48	86.38	3.4619
163.55	73.09	2.9297	175.04	79.47	3.1982	187.73	86.52	3.4668
163.75	73.20	2.9346	175.26	79.60	3.2031	187.97	86.66	3.4717
163.96	73.32	2.9395	175.48	79.72	3.2080	188.22	86.80	3.4766
164.16	73.43	2.9443	175.70	79.84	3.2129	188.46	86.93	3.4814

FIG. 57 – OIL AND DISCHARGE TEMPERATURE (CONT'D.)

Temp (°F)	Temp (°C)	Vin	Temp (°F)	Temp (°C)	Vin
188.71	87.07	3.4863	203.40	95.23	3.7549
188.96	87.21	3.4912	203.69	95.39	3.7598
189.21	87.35	3.4961	203.99	95.56	3.7646
189.46	87.48	3.5010	204.28	95.72	3.7695
189.71	87.62	3.5059	204.57	95.88	3.7744
189.96	87.76	3.5107	204.86	96.04	3.7793
190.21	87.90	3.5156	205.16	96.21	3.7842
190.46	88.04	3.5205	205.46	96.37	3.7891
190.71	88.18	3.5254	205.76	96.54	3.7939
190.96	88.32	3.5303	206.05	96.70	3.7988
191.22	88.46	3.5352	206.35	96.87	3.8037
191.47	88.60	3.5400	206.65	97.04	3.8086
191.73	88.75	3.5449	206.96	97.21	3.8135
191.98	88.88	3.5498	207.26	97.37	3.8184
192.23	89.02	3.5547	207.57	97.55	3.8232
192.49	89.17	3.5596	207.87	97.71	3.8281
192.75	89.31	3.5645	208.17	97.88	3.8330
193.01	89.46	3.5693	208.48	98.05	3.8379
193.27	89.60	3.5742	208.79	98.22	3.8428
193.53	89.75	3.5791	209.10	98.40	3.8477
193.79	89.89	3.5840	209.42	98.57	3.8525
194.05	90.03	3.5889	209.73	98.75	3.8574
194.31	90.18	3.5938	210.04	98.92	3.8623
194.57	90.32	3.5986	210.35	99.09	3.8672
194.84	90.47	3.6035	210.67	99.27	3.8721
195.10	90.62	3.6084	210.99	99.45	3.8770
195.37	90.77	3.6133	211.31	99.62	3.8818
195.63	90.91	3.6182	211.62	99.80	3.8867
195.90	91.06	3.6230	211.94	99.97	3.8916
196.16	91.21	3.6279	212.27	100.16	3.8965
196.43	91.36	3.6328	212.59	100.34	3.9014
196.70	91.51	3.6377	212.92	100.52	3.9063
196.97	91.66	3.6426	213.24	100.70	3.9111
197.24	91.81	3.6475	213.57	100.88	3.9160
197.51	91.96	3.6523	213.90	101.06	3.9209
197.78	92.11	3.6572	214.23	101.25	3.9258
198.06	92.26	3.6621	214.56	101.43	3.9307
198.33	92.41	3.6670	214.89	101.61	3.9355
198.61	92.57	3.6719	215.23	101.80	3.9404
198.88	92.72	3.6768	215.56	101.99	3.9453
199.15	92.87	3.6816	215.90	102.17	3.9502
199.43	93.02	3.6865	216.24	102.36	3.9551
199.71	93.18	3.6914	216.58	102.55	3.9600
199.99	93.34	3.6963	216.92	102.74	3.9648
200.27	93.49	3.7012	217.26	102.93	3.9697
200.55	93.65	3.7061	217.60	103.12	3.9746
200.83	93.80	3.7109	217.95	103.31	3.9795
201.11	93.96	3.7158	218.30	103.51	3.9844
201.39	94.11	3.7207	218.65	103.70	3.9893
201.68	94.27	3.7256	219.00	103.90	3.9941
201.97	94.44	3.7305	219.35	104.09	3.9990
202.25	94.59	3.7354	219.70	104.29	4.0039
202.54	94.75	3.7402	220.06	104.49	4.0088
202.82	94.91	3.7451			
203.11	95.07	3.7500			

FIG. 58 – DROP LEG REFRIGERANT SENSOR

Temp (°F)	Temp (°C)	Vin
0.01	-17.77	0.753
3.72	-15.71	0.831
7.21	-13.77	0.909
10.51	-11.94	0.987
13.65	-10.20	1.066
16.65	-8.53	1.144
19.56	-6.91	1.222
22.36	-5.36	1.300
25.09	-3.84	1.378
27.74	-2.37	1.456
30.34	-0.92	1.534
32.89	0.49	1.613
35.40	1.89	1.691
37.87	3.26	1.769
40.31	4.62	1.847
42.73	5.96	1.925
45.14	7.30	2.003
47.53	8.63	2.081
49.92	9.96	2.160
52.31	11.28	2.238
54.70	12.61	2.316
57.10	13.95	2.394
59.52	15.29	2.472
61.95	16.64	2.550
64.40	18.00	2.628
66.89	19.38	2.707
69.40	20.78	2.785
71.97	22.21	2.863
74.57	23.65	2.941
77.23	25.13	3.019
79.96	26.65	3.097
82.73	28.19	3.175
85.60	29.78	3.254
88.56	31.42	3.332
91.59	33.11	3.410
94.75	34.86	3.488
98.06	36.70	3.566
101.50	38.61	3.644
105.10	40.61	3.722
108.90	42.73	3.801
112.92	44.96	3.879
117.17	47.32	3.957
121.76	49.87	4.035

FIG. 59 – EVAPORATOR REFRIGERANT SENSOR

Temp (°F)	Temp (°C)	Vin
0.04	-17.76	1.135
2.79	-16.23	1.214
5.44	-14.76	1.292
8.02	-13.32	1.370
10.53	-11.93	1.448
12.98	-10.57	1.526
15.39	-9.23	1.604
17.75	-7.92	1.683
20.08	-6.62	1.761
22.38	-5.34	1.839
24.66	-4.08	1.917
26.92	-2.82	1.995
29.17	-1.57	2.073
31.41	-0.33	2.151
33.66	0.92	2.230
35.90	2.17	2.308
38.15	3.42	2.386
40.41	4.67	2.464
42.69	5.94	2.542
44.99	7.22	2.620
47.31	8.51	2.698
49.67	9.82	2.777
52.06	11.15	2.855
54.49	12.50	2.933
56.96	13.87	3.011
59.50	15.28	3.089
62.10	16.72	3.167
64.77	18.21	3.245
67.51	19.73	3.324
70.35	21.31	3.402
73.29	22.94	3.480
76.36	24.65	3.558
79.55	26.42	3.636
82.89	28.27	3.714
86.41	30.23	3.792
90.12	32.29	3.871
94.07	34.49	3.949
98.31	36.84	4.027
102.87	39.38	4.105
107.81	42.12	4.183
113.26	45.15	4.261
119.30	48.50	4.339
126.10	52.28	4.418

SECTION 18

REMOTE SETPOINTS

(SEE FIGS. 11, 12 & 14)

There are three different Remote operating Modes that can be selected at the Keypad: **Analog** Remote mode, **Digital** Remote Mode or **ISN** Remote Mode.

The Control Center can receive a remote Current Limit and/or a Remote Leaving Chilled Liquid Temperature Setpoint via the following:

Analog Remote Mode

- 0-10VDC Analog Input
- 2-10VDC Analog Input
- 0-20mA Analog Input
- 4-20mA Analog Input

Digital Remote Mode

- Pulse width Modulation (PWM) Input

ISN Remote Mode

- RS-232 Serial Port via MicroGateway

The Analog inputs are connected to the Microboard J22 as shown in Figure 12 and described below. Microboard Program Jumpers JP23 and JP24 must be positioned appropriately to receive either a 0-10VDC, 2-10VDC, 0-20mA or a 4-20mA signal. Refer to Table 1 "Microboard Program Jumpers" and explanation below for required configurations.

The PWM inputs are in the form of a 1 to 11 second Relay contact closure that applies 115VAC to the I/O Board TB4-19 (Leaving Chilled Liquid Temp) and TB4-20 (Remote Current Limit) for 1 to 11 seconds. Refer to Figure 14. The source of 115VAC is I/O Board TB4-1. The PWM input must be received at a frequency of at least once every 30 minutes. If not received within this time interval, the Program assumes the remote device is defective and defaults the Current Limit Setpoint to 100% and the Leaving Chilled Liquid Temperature Setpoint to the locally programmed Local **BASE** value.

The Microboard COM 4B RS-232 Serial Port (J2) receives the Setpoints in serial data form from the

MicroGateway located inside the Control Center enclosure. The MicroGateway receives Setpoints from remote external devices and transfers them to the Microboard.

CURRENT LIMIT

REMOTE CURRENT LIMIT SETPOINT with 0-10VDC, 2-10VDC, 0-20mA, 4-20mA or Pulse Width Modulation Signal – The Remote Current Limit setpoint can be reset over the range of 100% to 30% Full Load Amps (FLA) by supplying (by others) a 0-10VDC, 2-10VDC, 0-20mA, 4-20mA or 1 to 11 second Pulse Width Modulated (PWM) signal to the Control Center. The Control Center must be configured appropriately to accept the desired signal type as follows:

- The appropriate Remote Mode must be selected: **ANALOG** Remote Mode must be selected when using a voltage or current signal input. **DIGITAL** Remote Mode must be selected when using a **PWM** input.
- If **ANALOG** Remote Mode is selected, the **REMOTE ANALOG INPUT RANGE** setpoint must be set to "0-10VDC" or "2-10VDC" as detailed below, regardless of whether the signal is a voltage or current input signal type.
- Microboard Program Jumper JP23 must be positioned appropriately per the input signal type as detailed below. It is recommended that a qualified Service Technician position this jumper.

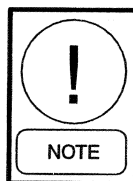

IMPORTANT! - *The signal type used for Remote Current Limit setpoint reset and the signal type used for Remote Leaving Chilled Liquid Temperature setpoint reset must be the same. For example, if a 0-10VDC signal is being used for Remote Leaving Chilled Liquid Temperature Reset, then a 0-10VDC signal must be used for Remote Current Limit Reset.*

0-10VDC

As shown in Fig. 12, connect input to Microboard J22-1 (signal) and J22-5 (Gnd). The setpoint varies linearly from 100% to 30% FLA as the input varies from 0 to 10VDC. This input will only be accepted when **ANALOG Remote Mode** is selected, the **REMOTE ANALOG INPUT RANGE** setpoint is set for "0-10 Volts" and Microboard Program Jumper JP23 has been removed. Calculate the setpoint for various inputs as follows:

$$\text{Setpoint (\%)} = 100 - (\text{VDC} \times 7)$$

For example, if the input is 5VDC, the setpoint would be set to 65% as follows:

$$\begin{aligned} \text{Setpoint (\%)} &= 100 - (5 \times 7) \\ &= 100 - 35 \\ &= 65\% \end{aligned}$$

2-10VDC

As shown in Fig. 12, connect input to Microboard J22-1 (signal) and J22-5 (Gnd). The setpoint varies linearly from 100% to 30% FLA as the input varies from 2 to 10VDC. This input will only be accepted when **ANALOG Remote Mode** is selected, the **REMOTE ANALOG INPUT RANGE** setpoint is set for "2-10 Volts" and Microboard Program Jumper JP23 has been removed. Calculate the setpoint for various inputs as follows:

$$\text{Setpoint (\%)} = 100 - [(\text{VDC} - 2) \times 8.75]$$

For example, if the input is 5VDC, the setpoint would be set to 74% as follows:

$$\begin{aligned} \text{Setpoint (\%)} &= 100 - [(5 - 2) \times 8.75] \\ &= 100 - [3 \times 8.75] \\ &= 100 - 26.25 \\ &= 74\% \end{aligned}$$

0-20mA

As shown in Fig. 11, connect input to Microboard J22-2 (signal) and J2-5 (Gnd). The setpoint varies linearly from 100% to 30% FLA as the input varies from 0mA to 20mA. This input will only be accepted when **ANALOG remote mode** is selected, the **REMOTE ANALOG INPUT RANGE** setpoint is set for "0-10 Volts" and Microboard Program Jumper JP23 has been placed on pins 1 and 2. Calculate the setpoint for various inputs as follows:

$$\text{Setpoint (\%)} = 100 - (\text{mA} \times 3.5)$$

For example, if the input is 8mA, the setpoint would be set to 72% as follows:

$$\begin{aligned} \text{Setpoint (\%)} &= 100 - (8 \times 3.5) \\ &= 100 - 28 \\ &= 72\% \end{aligned}$$

4-20mA

As shown in Fig. 11, connect input to Microboard J22-2 (signal) and J2-5 (Gnd). The setpoint varies linearly from 100% to 30% FLA as the input varies from 4mA to 20mA. This input will only be accepted when **ANALOG remote mode** is selected, the **REMOTE ANALOG INPUT RANGE** setpoint is set for "2-10 Volts" and Microboard Program Jumper JP23 has been placed on pins 1 and 2. Calculate the setpoint for various inputs as follows:

$$\text{Setpoint (\%)} = 100 - [(\text{mA} - 4) \times 4.375]$$

For example, if the input is 8mA, the setpoint would be set to 83% as follows:

$$\begin{aligned} \text{Setpoint (\%)} &= 100 - [(8 - 4) \times 4.375] \\ &= 100 - (4 \times 4.375) \\ &= 100 - 17.5 \\ &= 82.5 \\ &= 83\% \end{aligned}$$

PWM

The Pulse Width Modulation input is in the form of a 1 to 11 second relay contact closure that applies 115VAC to the I/O Board TB4-20 for 1 to 11 seconds. As shown in Fig. 14, connect dry closure relay contacts between I/O Board TB4-20 (signal) and TB4-1 (115VAC). The setpoint varies linearly from 100% to 30% as the relay contact closure time changes from 1 to 11 seconds. The relay contacts should close for 1 to 11 seconds at least once every 30 minutes to maintain the setpoint to the desired value. If a 1 to 11 second closure is not received within 30 minutes of the last closure, the setpoint is defaulted to 100%. A closure is only accepted at rates not to exceed once every 70 seconds. This input will only be accepted in **DIGITAL remote mode**. Calculate the setpoint for various pulse widths as follows:

$$\text{Setpoint (\%)} = 100 - [(\text{pulse width in seconds} - 1) \times 7]$$

For example, if the relay contacts close for 3 seconds, the setpoint would be set to 86% as follows:

$$\begin{aligned}
 \text{Setpoint (\%)} &= 100 - [(3 - 1) \times 7] \\
 &= 100 - (2 \times 7) \\
 &= 100 - 14 \\
 &= 86\%
 \end{aligned}$$

RS-232

As shown in Fig. 11, a setpoint can be received in serial data form at Microboard J2 from the GPIC.

LEAVING CHILLED LIQUID TEMPERATURE

REMOTE LEAVING CHILLED LIQUID TEMPERATURE SETPOINT with 0-10VDC, 2-10VDC, 0-20mA, 4-20mA or Pulse Width Modulation Signal – Remote Leaving Chilled Liquid Temperature setpoint reset can be accomplished by supplying (by others) a 0-10VDC, 2-10VDC, 0-20mA, 4-20mA or 1 to 11 second Pulse Width Modulated (PWM) signal to the Control Center. The **LEAVING CHILLED LIQUID TEMPERATURE** setpoint is programmable over the range of 38°F to 70°F (water applications); 36°F to 70°F (water applications with Smart Freeze protection enabled); or 10°F to 70°F (brine applications). The Remote input signal changes the setpoint by creating an offset above the locally programmed Leaving Chilled Liquid Temperature Base setpoint value. The setpoint can be remotely changed over the range of 10 or 20°F (as per the locally programmed **REMOTE RESET TEMPERATURE RANGE** setpoint) above the Local Leaving Chilled Liquid Temperature Setpoint. For example, if the Local setpoint is 40°F and the **REMOTE RESET TEMPERATURE RANGE** setpoint is programmed for 10°F, the Leaving Chilled Liquid Temperature setpoint can be remotely reset over the range of 40°F to 50°F. The setpoint received through the COM 4B RS-232 serial port is not an offset that is applied to the locally programmed **BASE** value as described above. Rather, it is an actual Setpoint value. The locally programmed value is not used as a **BASE** in this application.

The Control Center must be configured appropriately to accept the desired signal type as follows:

- The appropriate Remote Mode must be selected: **ANALOG** Remote Mode must be selected when using a voltage or current signal input. **DIGITAL** Remote Mode must be selected when using a PWM input.

- If **ANALOG** Remote Mode is selected, the **REMOTE ANALOG INPUT RANGE** setpoint must be set to “0-10VDC” or “2-10VDC” as detailed below, regardless of whether the signal is a voltage or current signal type.
- Microboard Program Jumper JP24 must be positioned appropriately per the input signal type as detailed below. It is recommended a qualified Service Technician position this jumper.

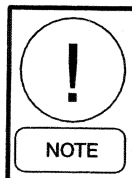

IMPORTANT! - The signal type used for Remote Leaving Chilled Liquid Temperature setpoint reset and the signal type used for Remote Current Limit setpoint reset must be the same. For example, if a 0-10VDC signal is being used for Remote Current Limit setpoint reset, then a 0-10VDC signal must be used for Leaving Chilled Liquid Temperature reset.

0-10VDC

As shown in Fig. 12, connect input to Microboard J22-3 (signal) and J22-5 (Gnd). A 0VDC signal produces a 0°F offset. A 10VDC signal produces the maximum offset (10 or 20°F above the Local Setpoint value). The setpoint is changed linearly between these extremes as the input varies linearly over the range of 0VDC to 10VDC. This input will only be accepted when **ANALOG** Remote mode is selected, the **REMOTE ANALOG INPUT RANGE** setpoint is set for “0-10VDC” and Microboard Program Jumper JP24 has been removed. Calculate the setpoint for various inputs as follows:

$$\text{Offset (°F)} = \frac{(\text{VDC})(\text{Remote Reset Temp Range})}{10}$$

$$\text{Setpoint (°F)} = \text{Local Setpoint} + \text{Offset}$$

For example, if the input is 5VDC and the Remote Reset Temp Range setpoint is programmed for 10°F and the Local Leaving Chilled Liquid Temperature setpoint is programmed for 40°F, the setpoint would be set to 45°F as follows:

$$\begin{aligned}
 \text{Offset (°F)} &= \frac{5 \times 10}{10} \\
 &= \frac{50}{10} \\
 &= 5^\circ\text{F}
 \end{aligned}$$

$$\begin{aligned}\text{Setpoint} &= 40 + 5 \\ &= 45^{\circ}\text{F}\end{aligned}$$

2-10VDC

As shown in Fig. 12, connect input to Microboard J22-3 (signal) and J2-5 (Gnd). A 2VDC signal produces a 0°F offset. A 10VDC signal produces the maximum allowed offset (10°F or 20°F above the Local Setpoint value). The setpoint is changed linearly between these extremes as the input varies over the range of 2VDC to 10VDC. This input will only be accepted when **ANALOG** remote mode is selected, the **REMOTE ANALOG INPUT RANGE** setpoint is set for "2-10VDC" and the Microboard Program Jumper JP24 has been removed. Calculate the setpoint for various inputs as follows:

$$\text{Offset } (^{\circ}\text{F}) = \frac{(\text{VDC} - 2)(\text{Remote Reset Temp Range})}{8}$$

$$\text{Setpoint } (^{\circ}\text{F}) = \text{Local Setpoint} + \text{Offset}$$

For example, if the input is 5VDC and the Remote Reset Temp Range setpoint is programmed for 10°F and the Local Leaving Chilled Liquid Temperature setpoint is programmed for 40°F, the setpoint would be set to 43.8°F.

$$\begin{aligned}\text{Offset } (^{\circ}\text{F}) &= \frac{(5 - 2)(10)}{8} \\ &= \frac{(3)(10)}{8} \\ &= \frac{30}{8} \\ &= 3.8^{\circ}\text{F}\end{aligned}$$

$$\begin{aligned}\text{Setpoint } (^{\circ}\text{F}) &= 40 + 3.8 \\ &= 43.8^{\circ}\text{F}\end{aligned}$$

0-20mA

As shown in Fig. 12, connect input to Microboard J22-4 (signal) and J22-5 (Gnd). A 0mA signal produces a 0°F offset. A 20mA signal produces the maximum allowed offset (10 or 20°F above the Local setpoint value). The setpoint is changed linearly between these extremes as the input varies over the range of 0-20mA. This input will only be accepted when **ANALOG** remote mode is selected, the **REMOTE ANALOG INPUT RANGE** setpoint is set for "0-10VDC" and Microboard Program Jumper J24 has been placed on pins 1 and 2. Calculate the setpoint for various inputs as follows:

$$\text{Offset } (^{\circ}\text{F}) = \frac{(\text{mA})(\text{Remote Reset Temp Range})}{20}$$

$$\text{Setpoint } (^{\circ}\text{F}) = \text{Local Setpoint} + \text{Offset}$$

For example, if the input is 8mA, the Remote Reset Temp Range Setpoint is programmed for 10°F and the Local Leaving Chilled Liquid Temperature setpoint is programmed for 40°F, the setpoint would be set to 44°F as follows:

$$\begin{aligned}\text{Offset } (^{\circ}\text{F}) &= \frac{(8)(10)}{20} \\ &= \frac{80}{20} \\ &= 4^{\circ}\text{F}\end{aligned}$$

$$\begin{aligned}\text{Setpoint } (^{\circ}\text{F}) &= 40 + 4 \\ &= 44^{\circ}\text{F}\end{aligned}$$

4-20mA

As shown in Fig. 12, connect input to Microboard J22-4 (signal) and J22-5 (Gnd). A 4mA signal produces a 0°F offset. A 20mA signal produces the maximum allowed offset (10 or 20°F above the Local Setpoint value). The setpoint is changed linearly between these extremes as the input varies over the range of 4-20mA. This input will only be accepted when **ANALOG** Remote mode is selected, the **REMOTE ANALOG INPUT RANGE** setpoint is set for "2-10VDC" and Microboard Program Jumper JP24 has been placed on pins 1 and 2. Calculate the setpoint for various inputs as follows:

$$\text{Offset } (^{\circ}\text{F}) = \frac{(\text{mA}-4)(\text{Remote Reset Temp Range})}{16}$$

$$\text{Setpoint } (^{\circ}\text{F}) = \text{Local Setpoint} + \text{Offset}$$

For example, if the input is 8mA, and the Remote Reset Temp Range setpoint is programmed for 10°F and the Local Leaving Chilled Liquid Temperature setpoint is programmed for 40°F, the setpoint would be set to 42.5°F as follows:

$$\begin{aligned}\text{Offset } (^{\circ}\text{F}) &= \frac{(8-4)(10)}{16} \\ &= \frac{(4)(10)}{16}\end{aligned}$$

$$= \frac{40}{16}$$

$$= 2.5^{\circ}\text{F}$$

$$\text{Setpoint } (^{\circ}\text{F}) = 40 + 2.5$$

$$= 42.5$$

PWM

The Pulse Width Modulation input is in the form of a 1 to 11 second relay contact closure that applies 115VAC to the I/O Board TB4-19 for 1 to 11 seconds. As shown in Fig. 14, connect dry closure relay contacts between I/O Board TB4-19 (input) and TB4-1 (115VAC). A contact closure time (pulse width) of 1 second produces a 0°F offset. An 11 second closure produces the maximum allowed offset (10 or 20°F above the Local Setpoint value). The relay contacts should close for 1 to 11 seconds at least once every 30 minutes to maintain the setpoint to the desired value. If a 1 to 11 second closure is not received within 30 minutes of the last closure, the setpoint is defaulted to the Local setpoint value. A closure is only accepted at rates not to exceed once every 70 seconds. This input will only be accepted in **DIGITAL** Remote mode. Calculate the setpoint for various pulse widths as follows:

$$\text{Offset } (^{\circ}\text{F}) = \frac{(\text{pulse width in seconds} - 1)(\text{Remote Reset Temp Range})}{10}$$

$$\text{Setpoint } (^{\circ}\text{F}) = \text{Local Setpoint} + \text{Offset}$$

For example, if the relay contacts close for 5 seconds and the Remote Reset Temp Range setpoint is programmed to 10°F and the Local Leaving Chilled Liquid Temperature setpoint is programmed for 40°F, the setpoint would be set to 44°F as follows:

$$\text{Offset } (^{\circ}\text{F}) = \frac{(5 - 1)(10)}{10}$$

$$= \frac{(4)(10)}{10}$$

$$= \frac{40}{10}$$

$$= 4^{\circ}\text{F}$$

$$\text{Setpoint } (^{\circ}\text{F}) = 40 + 4$$

$$= 44^{\circ}\text{F}$$

RS-232

As shown in Fig. 11, a Setpoint can be received in serial data form at the Microboard COM 4B serial port (J2) from the MicroGateway.

SECTION 19

HOT GAS BYPASS

(SEE FIG. 60)

With the optional Hot Gas Bypass feature, the Control Center modulates a valve located in the Hot Gas Bypass connection between the condenser and the evaporator to control the flow of gas to the evaporator. The valve is modulated in response to load and surging conditions.

A Hot Gas Bypass Screen, accessed from the COMPRESSOR Screen displays all the applicable parameters and allows a Service Technician to program the applicable setpoints and manually control the Hot Gas valve. If the chiller is equipped with the optional Hot Gas Bypass control, it must be Enabled from the OPERATIONS Screen using a procedure in the "System Calibration Service Setpoints and Reset Procedures" section of this book. If Disabled, the valve is driven to the fully closed position.

The Microboard controls the Hot Gas valve by sending a positioning command over the COM 3 RS-485 serial communications link to the optional **Analog I/O Board** that is mounted inside the control Center. The Analog I/O Board converts this command into a 2-10VDC signal and applies it to the Hot Gas Valve Actuator. A 2VDC signal drives the valve fully closed (0% position); a 10VDC signal drives the valve fully open (100% position). Positions between these extremes are linearly scaled. For example, 50% position would be achieved with a 6VDC signal. The actual valve position is displayed on the HOT GAS BYPASS Screen as 0% to 100%.

A 2.5K Ohm **PRV Potentiometer** mounted on the Pre-rotation Vanes (PRV) assembly provides the PRV position (0 to 100%) to the Analog I/O Board. A +12VDC source is applied to the potentiometer. This position value is sent over the RS-485 serial communications link to the Microboard, where it is displayed on the COMPRESSOR Screen. When the PRV are fully closed, the position is display as 0%; fully open displayed as 100%. Positions between these extremes are linearly scaled. To assure accuracy, a PRV Calibration procedure must be performed as detailed in the "System Calibration, Service Setpoints and Reset Procedures" section of this book. The PRV position is displayed as XX on the COMPRESSOR Screen and "Warning - Vanes Uncalibrated" is displayed on the System Details line of the display until the calibration is performed.

The Evaporator and Condenser pressure transducers provide these pressure values to the Microboard. The Microboard uses these values to calculate the **DELTA P/P** parameter as follows: [(condenser pressure - evaporator pressure) / evaporator pressure]. Although this parameter is not used in the Hot Gas Control, it represents compressor "Head" and is displayed on the Hot Gas Bypass Screen for reference only. These pressures are also used to detect when a surge occurs.

The Leaving Chilled Liquid Temperature thermistor provides the temperature to the Microboard. This value is subtracted from the Leaving Chilled Liquid Temperature Setpoint to produce the **TEMPERATURE DIFFERENTIAL** parameter. This parameter is indicative of chiller load.

When a surge is detected, the **SURGE DETECTED** LED illuminates for 5 seconds and the **TOTAL SURGE COUNT** is incremented. This count is the accumulated surge events that have been detected over the lifetime of the chiller. This value can be reset to zero using the procedure detailed in the "System Calibration, Service Setpoints and Reset Procedures" section of this book. This should not be arbitrarily performed. The **SURGE SENSITIVITY** setpoint can be used to make the detection more or less sensitive.

SETPOINTS

- **Surge Sensitivity** (0.3 to 1.3; default 0.3) – Determines the surge detection sensitivity. The smaller the number, the greater the sensitivity. Programmable in 0.1 increments. This setpoint is programmed on the Surge Protection Screen and is common to the Surge Protection feature.
- **Hold Period** (30 to 120 minutes; default 30) – This is the period of time after no more surges are detected that the Hot Gas valve closing will begin. It will be driven toward the closed position in increments equal to the Close Percentage setpoint at 10 minute intervals until fully closed. Programmable in 1 minute increments.
- **Close Percentage** (5 to 15%; default 5%) – This is the incremental amount that the Hot Gas valve will be closed at 10 minute intervals after the HOLD PERIOD has elapsed. Refer to HOLD PERIOD above.

- **Minimum Load** (0°F to 4°F; default 0°F) – This sets the Minimum Load override threshold. It is the offset below the Leaving Chilled Liquid Temperature Setpoint at which the Hot Gas Bypass valve will be opened to the position allowed per the MAXIMUM OPEN setpoint (25% to 100%). If “0” is entered for this value, this feature is disabled.
- **Maximum Open** (25% to 100%; default 100%) – This is the maximum allowed position for the Hot Gas valve during a Minimum Load override condition. Allows the user to adjust the quantity of hot gas for the local requirements.

OPERATION

While the chiller is shutdown, the Hot Gas valve is driven to the fully closed position. While the chiller is running, the valve is modulated in response to low load, high load or surge conditions. However, manual control can override this operation.

If the Leaving Chilled Liquid Temperature decreases to less than the **Minimum Load** setpoint, the valve is opened to the maximum allowed by the **Maximum Open** setpoint and “Override” is displayed as the Hot Gas Bypass Control mode on the Hot Gas Bypass Screen. For example, if the Minimum Load is set for 4°F and the Maximum Open is set for 80%, the valve will be positioned to 80% open when the Leaving Chilled Liquid Temperature decreases to more than 4°F below the Leaving Chilled Liquid Temperature setpoint. After this Minimum Load Override is initiated, as the Leaving Chilled Liquid Temperature rises to the Leaving Chilled Liquid Temperature setpoint, the valve is closed by an amount proportional to the difference between the temperature delta and the minimum Load setpoint. In this example, when the Leaving Chilled Liquid Temperature increases to 2°F below the Leaving Chilled Liquid Temperature setpoint, the valve will be positioned to 40% open. The valve is closed accordingly until the temperature delta is 0°F.

If the Pre-rotation Vanes are more than 95% open and the Leaving Chilled Liquid Temperature is at least 5°F above the Leaving Chilled Liquid Temperature setpoint, the valve is set to one-half of its present position for 10 minutes. After the 10 minutes have elapsed, the valve is driven fully closed.

If the chiller is equipped with a Variable Speed Drive (VSD), whenever the VSD is running at < full speed (50/60Hz), the Hot Gas Bypass valve is driven to the

fully closed position and “Override” is displayed as the Hot Gas Bypass Control Mode.

If none of the above conditions are in effect, the Hot Gas Bypass valve is driven to the fully closed position, until a surge condition is detected. When a surge is detected, the Hot Gas valve is opened a certain percentage every few minutes until the surging stops or the valve is fully opened as follows:

- If Hot Gas valve is fully closed, it is driven to the 50% position. There will be no valve response to surge events for the next 5 minutes.
- If Hot Gas valve position is < 35%, it is driven to the 50% position. There will be no valve response to surge events for the next 3.5 minutes.
- If Hot Gas valve position is > 35% but < 50%, it is driven to the 50% position. There will be no valve response to surge events in the next 2 minutes.
- If Hot Gas valve position is >50%, it is driven open another 10%. There will be no valve response to surge events in the next 2 minutes.

After the chiller has not surged for the period of time programmed as the **HOLD PERIOD** setpoint, the valve is driven toward the closed position at 10 minute intervals by incremental amounts determined by the **CLOSE PERCENTAGE** setpoint. After it is fully closed, it remains there until another surge is detected.

Whenever the Hot Gas valve is partially or fully open, the existing safety check that subtracts the evaporator saturation temperature from the leaving chilled liquid temperature changes the range from standard range of (-2.5°F to +25°F) to (-5.0°F to +25°F). Whenever the hot gas bypass valve is closed or not used, this safety check uses the standard values.

If RS-485 serial communications between the Microboard and the Analog I/O Board are lost continuously for 20 seconds, “Warning – External I/O – Serial Communications” is displayed on the System Details line of the Display and the Hot Gas valve will remain at the position when communications were lost.

MANUAL CONTROL

The Hot Gas Bypass valve can be manually controlled from the Hot Gas Bypass Screen in Service access level. Manual control has priority over Minimum Load Override, Variable Speed Drive Override and Automatic control.

When the OPEN or CLOSE key is pressed, the valve position will be increased or decreased by 5% to a maximum of 100% or minimum of 0%. Each time either key is pressed, the LED in the respective key will illuminate for 2 seconds. The Hot Gas Bypass Control Mode will display "Manual".

ANALOG I/O BOARD

The optional Analog I/O Board mounts inside the Control Center, on the upper right hand side of the Control Center. It receives the Hot Gas valve positioning command from the Microboard over the RS-485 serial communications link and converts this digital value to a 2-10VDC analog control signal that is applied to the valve actuator. The scaling of this signal is as described above. Valve position is displayed on the HOT GAS BYPASS Screen as 0% (closed) to 100% (fully open). Positions between these extremes are linearly scaled.

The Pre-rotation Vanes (PRV) potentiometer (2.5K Ohms) is connected to P1, providing a 0 to 5VDC voltage from a +12VDC source that represents PRV position. Potentiometer rotation is limited to 37 degrees.

PRV position is displayed on the COMPRESSOR Screen as 0 (closed) to 100% (fully open). Positions between these extremes are linearly scaled. To assure position accuracy, a calibration procedure must be performed as detailed in the "System Calibration, Service Setpoints and Reset Procedures" section of this book. The PRV position is transmitted to the Microboard via the RS-485 serial communications link.

The Analog I/O Board must be configured properly for the Hot Gas control. The on-board Program Jumpers must be configured as follows:

JUMPER	POSITION
J1	PINS 2 & 3
J26	PINS 2 & 3
J39	PINS 1 & 2

There must be a 499 Ohm, 1%, 1/2 watt resistor connected between P10-2 and P10-5. This converts the normal 4-20ma Analog I/O Board output to a 2-10VDC valve positioning output, required by the Hot Gas valve actuator.

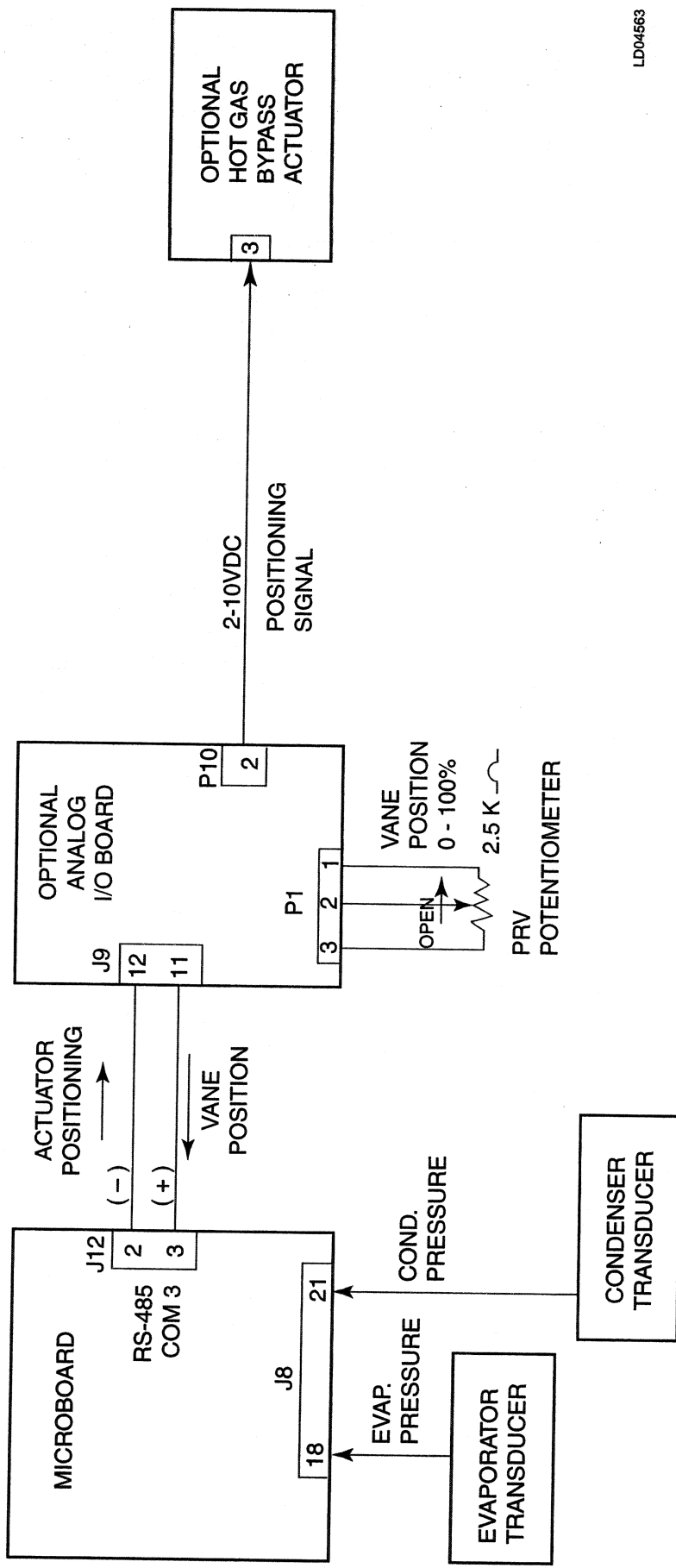

LD04563

FIG. 60 - INTERFACE, HOT GAS BYPASS

SECTION 20

SMART FREEZE PROTECTION

The **Smart Freeze** feature prevents nuisance chiller shutdowns due to brief periods of chilled liquid flow fluctuations or other brief operating conditions that would normally cause Low Evaporator Pressure Safety shutdowns. With this feature enabled and activated, the chiller is permitted to ride through these temporary conditions. Also, this feature allows the Leaving Chilled Liquid temperature Setpoint to be set as low as 36.0°F. **Smart Freeze** protection can be enabled or disabled at the Keypad, by a Service Technician, using a procedure detailed in the “System Calibration, Service Setpoints and Reset Procedures” section of this book. It **cannot** be used in Brine cooling mode.

The basis of this feature is that the chilled liquid contains an amount of heat, which cannot be eliminated immediately. Therefore, it requires a certain amount of time for the liquid to change to a solid. During this period of time, those parameters that determine when solidification will occur, are evaluated and the appropriate Low Evaporator Temperature shutdown threshold is applied. This threshold could be lower, but not higher than the normal Safety threshold.

Smart Freeze protection uses the Evaporator Refrigerant Temperature as one of the variables to determine when freezing is imminent. If the chiller is equipped with the Evaporator Refrigerant Temperature Sensor (RT7), and the sensor is enabled using the “System Calibration, Service Setpoints and Reset Procedures” section of this book, this value is used as the refrigerant temperature. Otherwise, the Evaporator Saturation Temperature (as derived from the output of the Evaporator Pressure Transducer. The pressure is converted to a temperature via the appropriate refrigerant “pressure/temperature lookup table”) is used as the refrigerant temperature.

When **Smart Freeze** protection is Enabled, the Leaving Chilled Liquid Temperature Setpoint can be set as low as 36.0°F. If set to < 38.0°F, the **LEAVING CHILLED LIQUID – LOW TEMPERATURE** cycling shutdown threshold becomes a minimum of 34.0°F.

Unless **Smart Freeze** protection is **activated**, the fixed Low Evaporator Pressure Safety thresholds (R11 = <5.4 PSIA) (R123 = 4.4 PSIA) are used. **SMART FREEZE** protection is **activated** only when the feature is enabled **AND** the Leaving Chilled Liquid Temperature Setpoint is < 38°F. Once activated, the total number of seconds that the evaporator refrigerant temperature is below the freeze threshold is counted. The freeze threshold is 32.8°F (refrigerant temp sensor RT7) or 34.0°F (evaporator saturation temp). The count is incremented once for every second the evaporator refrigerant temperature is below the freeze threshold and decrements once for every second it is above the freeze threshold (but it never decrements below zero). Thus, if the evaporator refrigerant temperature goes below the freeze threshold for 30 seconds, then goes above it for 10 seconds, then goes below the threshold for 5 seconds, the total number of seconds the evaporator refrigerant temperature was below the freeze threshold was 25 seconds. If Smart Freeze is no longer activated due to the Leaving Chilled Liquid Temperature Setpoint being raised to ≥ 38.0°F, the total number of seconds being tracked is set to zero.

The number of seconds it will take the chilled liquid to freeze is based on how far the evaporator refrigerant temperature is below the freeze threshold as follows:

$$\text{Number of seconds to freezing} = \frac{(4053.7)}{(\text{freeze threshold} - \text{evaporator refrigerant temperature})}$$

Thus, if the Evaporator Saturation Temperature is being used as the evaporator refrigerant temperature, and that temperature is 26.0°F, it would take 8 minutes and 26 seconds for the chilled liquid to freeze.

When the total number of seconds the evaporator refrigerant temperature is below the freeze threshold exceeds the “Number of seconds to freezing”, a safety shutdown is performed and “**EVAPORATOR – LOW PRESSURE – SMART FREEZE**” is displayed on the System details line of the display.

Even though **Smart Freeze** protection is enabled and activated, the Pre-rotation Vanes Load inhibit still occurs at the same thresholds as with normal operation; inhibit at ≤ 5.5 PSIA (R11) and ≤ 4.5 PSIA (R123). As in normal operation, loading will be allowed when the pressure increases to ≥ 5.6 PSIA (R11) and ≥ 4.7 PSIA (R123).

The following is a summary of the operation with **Smart Freeze** enabled and disabled:

SMART FREEZE DISABLED:

- Minimum Leaving Chilled Liquid Setpoint: 38.0°F
- Low Chilled Liquid Temp cycling shutdown threshold: 1° to 34.0°F below the Leaving Chilled Liquid temp Setpoint, as programmed, or a minimum of 36.0°F.
- Low Evaporator Pressure safety shutdown threshold: R11 = < 5.4 PSIA; R123 = < 4.4 PSIA
- PRV Load Inhibit: R11 = ≤ 5.5 PSIA; R123 = ≤ 4.5 PSIA
Load Inhibit disable: R11 = ≥ 5.6 PSIA; R123 = ≥ 4.7 PSIA

SMART FREEZE ENABLED:

- Minimum Leaving Chilled Liquid Setpoint: 36.0°F

- *If the Leaving Chilled Liquid Temperature Setpoint is $\geq 38.0^\circ\text{F}$:*
 1. The Low Leaving Chilled Liquid Temperature Cycling shutdown threshold: 1 to 34.0°F below the Leaving Chilled Liquid Temperature Setpoint, as programmed, or a minimum of 36.0°F.
 - 2.) The Low Evaporator Pressure Safety shutdown threshold is the same as **Smart Freeze Disabled** above.
- *If the Leaving Chilled Liquid Temperature Setpoint is $< 38.0^\circ\text{F}$:*
 1. The Low Leaving Chilled Liquid Temperature Cycling shutdown threshold: 1 to 3.0°F below the Leaving Chilled Liquid Temperature Setpoint, as programmed, or a minimum of 34.0°F.
 2. Low Evaporator Pressure shutdown threshold: Determined by how far the evaporator refrigerant temperature is below the freeze threshold of 32.8°F (refrigerant temperature sensor RT7) or 34.0°F (Evaporator Saturation Temperature) and the total number of seconds it remains there. Refer to explanation above.
- PRV Load Inhibit: same as **Smart Freeze Disabled** above.
- Load Inhibit Disable: same as **Smart Freeze Disabled** above.

SECTION 21

SURGE PROTECTION

This feature applies to Flash Memory Card version C.MLM.02.02.xxx and later.

The Surge Protection feature detects surge events and provides a running count of the events that occur over the lifetime of the chiller (up to a maximum of 65535). If excess surging is detected, it can be configured to shut-down the chiller or initiate a special surge correction/avoidance mode or simply display a warning message.

The SURGE PROTECTION Screen, accessible from the COMPRESSOR Screen, displays all parameters relevant to this feature. All setpoints relating to this feature are maintained on this screen.

SURGE DETECTION

Surge events are detected by monitoring the relationship between the Condenser pressure and Evaporator pressure while the chiller is running. When the difference between these pressures decreases transiently and remains so for a period of time described below, and then makes a positive transition within 7 seconds, a surge event has been detected.

The surge detection sensitivity can be adjusted with the SURGE SENSITIVITY setpoint. It is adjustable over the range of 0.3 to 1.3 in 0.1 increments. Default value is 0.3. The smaller the number, the greater the sensitivity.

The Evaporator pressure transducer output is subtracted from the Condenser pressure output to determine the differential. If either of the following negative transitions occur in the differential followed by a 0.061VDC positive differential transition within 7 seconds, a surge event is detected:

- If the differential decreases $\geq 0.6\text{VDC}$ for ≥ 0.260 seconds.
- If the differential decreases $\geq x.x\text{VDC}$ for ≥ 0.390 seconds.

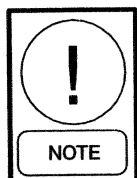

$x.x\text{VDC}$ calculated as $[(\text{surge sensitivity setpoint} \times 300) \times 1.22] + 1000$

Each time a surge event is detected, the SURGE DETECTED LED indicator on the SURGE PROTECTION Screen illuminates for 5 seconds and the TOTAL SURGE COUNT increments 1 count.

The TOTAL SURGE COUNT can be reset to zero using the CLEAR SURGE COUNT key with the ADMIN access level.

EXCESS SURGE DETECTION

An excess surge condition is detected by comparing the number of surge events that occur in a selectable time period to a selectable threshold.

If the number of surge events (Surge Window Count) detected in the time period programmed as the COUNT WINDOW setpoint (1 to 5 minutes; default 5) exceed the threshold programmed as the COUNT LIMIT setpoint (4 to 20; default 4) an excess surge condition has been detected.

Unless the SHUTDOWN or EXTENDED RUN features have been enabled, as explained below, the chiller will continue to run under the same conditions displaying "Warning – Excess Surge Detected". This message will be displayed until manually reset with the Warning Reset key in Operator access level.

SURGE PROTECTION

The Control Center can be configured to take the following courses of action when an excess surge condition has been detected. The SHUTDOWN setpoint is used to invoke a safety shutdown. The EXTENDED RUN setpoint is used to invoke a special 10 minute surge correction/avoidance mode that temporarily eliminates the conditions causing the surging, while allowing the chiller to continue to run. However, if the Hot Gas Bypass control is Enabled, the Hot Gas Bypass Valve position must be 100% before the Extended Run mode is implemented. If the chiller is equipped with a compressor motor Variable Speed Drive, the output frequency must be at full speed (50Hz/60Hz) before the Extended Run mode is implemented. If the chiller is equipped with Hot Gas Bypass and compressor motor Variable Speed Drive, both conditions must be met before Extended Run is implemented.

- If the SHUTDOWN setpoint is Enabled, and the EXTENDED RUN setpoint is Disabled, a safety shutdown will be performed and “Surge Protection – Excess Surge” is displayed.
- If the SHUTDOWN setpoint is Disabled and the EXTENDED RUN setpoint is Enabled, the Pre-rotation Vanes are driven closed for 10 minutes and “Warning – Surge Protection – Excess surge Limit” is displayed. When the 10 minutes have elapsed, if the Surge Window Count is \leq the Count Limit, this message and load inhibit are automatically cleared, otherwise another 10 minute period is initiated. Alternating with this message is “Warning – Excess Surge Detected” that is displayed until manually reset with the Warning Reset key in OPERATOR access level. During the 10-minute period, a countdown timer on the Surge Protection Screen displays the time remaining in the period. See Hot Gas Bypass and compressor motor Variable Speed Drive exception above.
- If both the SHUTDOWN and EXTENDED RUN setpoints are Enabled, the 10 minute Extended Run period is invoked as above. However, if the SURGE WINDOW COUNT exceeds the COUNT LIMIT at the end of the 10 minute Extended Run period, a safety shutdown is performed and “Surge Protection – Excess Surge” is displayed.

SECTION 22

SYSTEM CALIBRATION, SERVICE SETPOINTS AND RESET PROCEDURES

The chiller is supplied from the YORK Factory with all factory mounted components fully calibrated. The following procedures are used to verify these calibrations or calibrate a component after it has been field replaced.

Programmable Service Setpoints are used by the Program to control critical chiller operation. Also, some of these Setpoints can be used to enable or disable certain features. Although they have been entered at the YORK Factory, they can be changed by a field Service Technician that has logged in at **SERVICE** access level. If the **BRAM** battery backed memory device (U52) is field replaced, all of the programmed setpoints will be lost. They will have to be reentered into the new **BRAM**. Each of these Setpoints is described below. Programming procedures and Control Center Keypad operation required in the procedures below are detailed in YORK Operation Manual 160.55-O1. In general, the following procedure is used to enter Setpoints in this section:

1. Unless noted otherwise in procedures below, log in at **SERVICE** access level using Password **1380**.
2. Select the appropriate Display Screen.
3. Press the desired Setpoint key.
A dialog box appears, giving the minimum and maximum allowed values, Default value and present value. The dialog box can be canceled at any time by pressing the **CANCEL (X)** key.
4. If the dialog box begins with the word "Enter", use the numeric keys to enter the desired value. Leading zeroes are not necessary. Press the **.** key to place a decimal point at the appropriate place. Pressing the **.** key displays the Default value. Pressing the **-** key clears the entry. The **◀** key is a backspace key and causes the entry point to move back one space. If the dialog box begins with "Select" or "Enable", use the **◀** and **▶** keys to select the desired value. The **◀** key decreases the value. The **▶** key increases the value.
5. Press the **ENTER (✓)** key. If the value is within range, it is accepted and the dialog box disappears. The chiller will begin to operate based on the new value. If out of range, the value is not accepted and a message describing why it is not acceptable is displayed momentarily.

Some Safety shutdowns will not permit the chiller to start until a special reset procedure is performed. These reset procedures require **SERVICE** access level and should not be performed by anyone other than a Service Technician. Each of these procedures is described below.

ELECTRO-MECHANICAL STARTER APPLICATIONS

If the Compressor Motor is driven by an Electro-Mechanical Starter, the Control Center is equipped with a CM-2 Current Module along with supporting components Diode Bridge (DB) and Calibration Resistors (RES), as described in a previous chapter of this book. The following procedures can be used to verify the calibration and perform the calibration if necessary. In addition to the calibration, Switch S1 and Potentiometer R16 have to be set appropriately on the CM-2 Module. If the CM-2 and/or RES are field replaced, field calibration is necessary.

CM-2 Settings:

1. Place Switch S1 in the appropriate position per the Starter type:
UP: Y-Delta or Auto-transformer Starter
Down: All others
2. Calculate LRA/FLA ratio by dividing the Motor Lock Rotor Amps by the chiller Full Load Amps (LRA/FLA = ratio) and then adjust Potentiometer R16 to the ratio value.

Calibration Verification:

1. At the Keypad, log in at **SERVICE** access level using Password **1380**.
2. Select **MOTOR** Screen and set Current Limit and Pulldown Demand Limit Setpoints to 100% FLA.
3. Run chiller. Read compressor motor current in Phase A, B, and C using a clamp-on Ammeter. Apply ammeter to highest Phase.
4. Select **COMPRESSOR** Screen.
5. Manually operate the Pre-rotation Vanes by pressing the **OPEN** and **CLOSE** Keypad keys as required to achieve a motor current equivalent to 100% FLA as indicated by the clamp-on Ammeter. The motor current value on the Display should indicate 100% FLA.

6. Manually operate the Pre-rotation Vanes by pressing the **OPEN** and **CLOSE** keys as required to achieve a motor current equivalent to 105% FLA as indicated by the clamp-on Ammeter. The 105% LED on the CM-2 Module should illuminate.

If the calibration verification does not perform as above, the following Calibration procedure will have to be performed:

Calibration:

1. At the Keypad, log in at **SERVICE** access level using password **1 3 8 0**.
2. Select **MOTOR** Screen and set Current Limit and Pulldown Demand Limit Setpoints to 100% FLA.
3. Select **COMPRESSOR** Screen.
4. Run chiller and read compressor motor current in Phase A, B and C using a clamp-on Ammeter. Apply Ammeter to highest Phase.
5. Manually operate the Pre-rotation Vanes by pressing the **OPEN** and **CLOSE** Keypad keys as required to achieve a motor current equivalent to 100% FLA as indicated by the clamp-on Ammeter. The voltage across Variable Resistors (RES) should be 0.90 to 1.05VDC. Measure this voltage by connecting a Voltmeter at CM-2 Board J1-2 (+) to J1-1(-). If necessary, adjust RES to achieve this value. Figure 38 contains formulas to calculate the resistance of RES required to achieve this voltage. Adjust both resistors equally such that the combined resistance equals the calculated value.
6. Manually operate the Pre-rotation Vanes by pressing the **OPEN**, **CLOSE** and **HOLD** Keypad keys, as required, to achieve a motor current equivalent to 105% FLA as indicated by the clamp-on Ammeter. Loosen locking nut on Potentiometer R8 on CM-2 and adjust until the CM-2 Module 105% LED illuminates. Counterclockwise increases signal level; Clockwise decreases signal level. Tighten locking nut.
6. Manually operate the Pre-rotation Vanes by pressing the **OPEN** and **CLOSE** Keypad keys, as required, to achieve a motor current equivalent to 100% FLA as indicated by the clamp-on Ammeter. Loosen locking nut on Potentiometer R34 on CM-2 and adjust until the motor current value on the Display indicates 100% FLA. Clockwise increases the signal level; Counterclockwise decreases the signal level. Tighten locking nut.

SOLID STATE STARTER APPLICATIONS

The chiller could be equipped with either of two different YORK Solid State Starters. New production chillers after August 1999 are equipped with the Mod "B" serial data interface Liquid Cooled Solid State Starter (LCSSS). Earlier vintage chillers, such as those encountered in retrofit applications are equipped with the Style "A" multiplexed data interface LCSSS. Microboard Program Jumper JP39 must be positioned to invoke the appropriate Microboard/Program operation for the starter applied (Refer to Table 1). A description of these starters is contained in the Solid State Starter section of this book. The procedures for both starters are listed below.

MOD "B" SERIAL DATA INTERFACE LIQUID COOLED SOLID STATE STARTER

Complete details of the operation of this starter are contained in YORK Service Manual 160.00-O2.

1. At the Keypad, log in at **SERVICE** Access level using Password **1 3 8 0**.
2. Select **MOTOR** Screen.
3. Enter the following setpoints using the procedures below:

Full Load Amps:

This is the Full Load Amps (FLA) of the chiller as listed on the Sales Order Screen. The Microboard uses the programmed value to perform Current Limit functions and display compressor motor current in terms of %FLA.

1. Press **FULL LOAD AMPS** key.
2. Use numeric keypad keys to enter correct value.
3. Press **ENTER** (✓) key.

Start Current:

The Logic/Trigger Board will limit compressor motor current to this value during starting. The correct value is (0.45 x Delta Locked Rotor amps), as listed on the **SALES ORDER** Screen.

1. Press **STARTING CURRENT** key.
2. Use numeric keypad keys to enter correct value.
3. Press **ENTER** (✓) key.

Voltage Range

This is the compressor motor AC power line application. Selections are 200-208, 220-240, 380, 400, 415, 440-480, 550-600 and Disabled. The Microboard uses the programmed value to determine the overvoltage and undervoltage shutdown thresholds for "LCSSS – HIGH SUPPLY LINE VOLTAGE" and "LCSSS – LOW SUPPLY LINE VOLTAGE" cycling shutdowns as described in Operation Manual 160.55-O1. If **DISABLED** is selected, the shutdown thresholds will be ignored. This check should not be arbitrarily disabled.

1. Press **VOLTAGE RANGE** key.
2. Use ◀ and ▶ keys to scroll to desired value.
3. Press **ENTER (✓)** key.

Open SCR Enable/Disable:

This allows the Open SCR safety check, performed by the Logic/Trigger Board, to be disabled. **This must NEVER be disabled unless advised by the YORK factory.**

1. Press **OPEN SCR** key.
2. Use ◀ and ▶ keys to select Enable or Disable.
3. Press **ENTER (✓)** key.

Shorted SCR Enable/Disable:

(Flash Memory Card version C.MLM.02.01 or later)
This allows the Shorted SCR safety check, performed by the Logic/Trigger Board, to be disabled. **This must NEVER be disabled unless advised by the YORK factory.**

1. Press **SHORTED SCR** key.
2. Use ◀ and ▶ keys to select Enable or Disable.
3. Press **ENTER (✓)** key.

Kilowatt Hours (KWH) Reset:

This allows the KWH to be set to a desired starting value in the event the BRAM has to be field replaced. **This must never be arbitrarily performed.**

1. Press **KWH RESET** key.
2. Use numeric keypad keys to enter desired value.
3. Press **ENTER (✓)** key.

MOD "A" MULTIPLEXED DATA INTERFACE LIQUID COOLED SOLID STATE STARTER

If the chiller is equipped with this model starter the starter Logic Board is located in the Control Center. Operation of this board and overall starter operation is contained in YORK Service Manual 160.46-OM3.1.

The following procedures can be used to verify the calibration and perform the calibration if necessary. If the Logic Board is field replaced, field calibration is necessary. Logic Board Program Jumper JP5 (300V/600V) must be placed in the appropriate position per the compressor motor AC power line.

Logic Board Program Jumper:

Place Jumper J5 (300V/600V) in appropriate position per the Compressor Motor AC Power Line application as follows:

- 600V** - Place over pins 1 & 2 for 380/400/415, 440/460/480 or 550/575/600VAC applications.
- 300V** - Place over pins 2 & 3 for 200/208 or 220/230/240VAC applications.

Setpoints:

1. At the Keypad, log in at **SERVICE** access level using password **1 3 8 0**.
2. Select **MOTOR** Screen.
3. Enter the following Setpoints using procedures below:

Full Load Amps :

This is the Full Load Amps (FLA) of the chiller as listed on the Sales Order Screen. The Microboard uses the programmed value to perform Current Limit functions and display compressor motor current in terms of % FLA.

1. Press **FULL LOAD AMPS** key.
2. Use numeric keypad keys to enter correct value.
3. Press **ENTER (✓)** key.

Voltage Range:

This is the AC Power line voltage applied to the Compressor Motor. Selections are: 200-208, 220-240, 380, 400, 415, 440-480, 550-600 and Supply Voltage Range Disabled. The Microboard uses the programmed selection to determine the overvoltage and undervoltage thresholds for **Starter High Supply Line Voltage** and **Starter Low Supply Line Voltage** cycling shutdowns as described in Operator Manual 160.55-O1. If Supply Voltage Range Disabled is selected, the thresholds will be ignored and these shutdowns will not occur. This check should not be arbitrarily disabled.

1. Press **VOLTAGE RANGE** key.
2. Use ◀ and ▶ keys to scroll to desired value.
3. Press **ENTER (✓)** key.

Current Unbalance Check Enable/Disable:

While the chiller is running, if the compressor Motor current in phase A, B and C becomes unbalanced, a Safety shutdown is performed. Refer to Operator Manual 160.55-O1 for complete description of this check. This Setpoint allows the check to be enabled or disabled. If enabled, the check is performed; if disabled, the check is not performed.

1. Press **CURRENT UNBALANCE** key.
2. Use ◀ and ▶ keys to select Enable or Disable.
3. Press **ENTER (✓)** key.

Calibration Verification:

At the Keypad, login at **SERVICE** access level using password **1 3 8 0**.

1. Compressor Motor current display accuracy -
 - a. Run chiller.
 - b. Select **COMPRESSOR** Screen.
 - c. Use the Pre-rotation Vanes **HOLD** keypad key to stabilize the Compressor Motor current.
 - d. Measure phase A, B and C Compressor Motor current with a clamp-on ammeter. Compare the Ammeter values with displayed motor current values. If displayed values are not within $\pm 5\%$ of Ammeter values, refer to Solid State Starter Service Manual 160.46-OM3.1 to troubleshoot Starter.
2. Start Current - Proper starting current is (45% x Delta locked Rotor amps).
 - a.) Select **COMPRESSOR** Screen.
 - b.) Start chiller and monitor Compressor Motor starting current in phase A, B and C on the **COMPRESSOR** Screen.

Highest phase should be equivalent to (45% x Delta Locked rotor amps).
3. Overload -
 - a. Select **COMPRESSOR** Screen.
 - b. Run chiller and monitor Compressor Motor current on the **COMPRESSOR** Screen.
 - c. Manually operate the Pre-rotation Vanes by pressing the **OPEN**, **CLOSE** and **HOLD** keys, as required, until the highest phase indicates a current equivalent to 105% FLA.

The Display should indicate 105% and the 105% LED on the Solid State Starter Logic Board should illuminate when the 105% FLA value is reached.

If the calibration verification does not perform as above, one or both of the following Calibration procedures will have to be performed:

Calibration:

At the Keypad, log in at **SERVICE** access level using password **1 3 8 0**.

1. Start Current -
 - a. Select **COMPRESSOR** Screen.
 - b. Loosen locking nut on Solid State Starter Logic Board Potentiometer R38.
 - c. Start chiller and monitor Compressor Motor starting current in Phase A, B and C on the **COMPRESSOR** Screen.
 - d. While chiller is starting, adjust **START CURRENT** potentiometer (R38) on Solid State Starter Logic Board to achieve the proper starting current of (0.45 x Delta Locked rotor Amps) on the highest phase. Turning R38 Clockwise increases current; Counterclockwise decreases current. Multiple starts could be required to achieve the correct calibration. Tighten locking nut.
2. Overload -
 - a. Select **COMPRESSOR** Screen.
 - b. Run Chiller and monitor Compressor Motor current on the **COMPRESSOR** Screen.
 - c. Manually operate the Pre-rotation Vanes by pressing the **OPEN**, **CLOSE** and **HOLD** keypad keys, as required, until the highest phase indicates a current equivalent to 105% FLA. Adjust **OVERLOAD** potentiometer (R44) on Solid State Starter Logic Board until the 105% FLA LED illuminates. Clockwise increases signal level; Counterclockwise decreases signal level. Tighten locking nut.

COMPRESSOR MOTOR VARIABLE SPEED DRIVE APPLICATIONS

If the Compressor Motor is driven by the YORK Variable Speed Drive (VSD), the Control Center is equipped with an Adaptive Capacity Control (ACC) Board. Operation of this board and overall VSD operation is detailed in YORK Form 160.00-M1. There are two calibrations that have to be performed; VSD Full Load Amps and Pre-rotation Vanes position Potentiometer.

The **VSD Full Load Amps** value is the chiller full load amps value as listed on the Sales Order. It is used by the Program to initiate Current Limit at 100% and 104% FLA.

The **PRV Calibration** establishes the voltage feedback to the ACC Board at the fully closed and fully open positions. Since the feedback between these extremes is linear, the ACC Board will then know the actual PRV position at all times. PRV position is required for the speed control and surge prevention. If this procedure is not performed or not performed successfully, variable speed control is inhibited.

There are two setpoints that affect VSD operation; **Surge Margin** and **Stability Limit**. They should **never** be changed unless advised by YORK Factory Service. The Surge Margin Setpoint allows the entire surge map to be adjusted up by a fixed offset value. It is programmable over the range of 0 to 25.0 Hz. The Stability Limit Setpoint determines whether a surge event is stored in the compressor map. When the Leaving Chilled Liquid Temperature is within +0.3 and -0.8°F of the Setpoint and the rate of change of this liquid exceeds the programmed Stability Limit index, the system is considered unstable and a surge event that occurs under these conditions is not stored. The index is programmable over the range of 1000 to 7000, with the Default or nominal being 4500. The procedure to change these is described below.

The **ACC Surge Map** can be printed. By connecting a Printer and performing the procedure below, all previously established surge points can be printed. Also, while leaving a Printer connected, all new surge Points can be printed as they are established. The Map can be cleared using the procedure below. However, it should never be cleared unless advised by the YORK Factory.

If required, an operating point can be established as a Surge Point by pressing the Manual surge Point key and then pressing a switch on the ACC Board. The operating conditions at that instant will be captured and stored as a surge point. This is known as a **Manual Surge Point**. Refer to procedure below.

The **Kilowatt Hour (KWH)** accumulation can be cleared or set to a value using the **KWH RESET** key as described below. This should not be performed unless advised by the YORK Factory.

Full Load Amps Calibration:

1. Place **COMPRESSOR START/STOP** Switch in the **STOP-RESET (O)** position.
2. At the keypad, log in at **SERVICE** access level using password **1 3 8 0**.
3. Select **VSD DETAILS** Screen from the **MOTOR Screen**.

4. In the VSD, locate the small trimpot located in the upper-middle area of the VSD Logic Board.
5. While monitoring the **VSD Full Load Amps 000.0** A message on the **VSD DETAILS** Screen, adjust this trimpot until the correct Full Load Amps value is displayed. Clockwise will increase the value.

Pre-rotation Vanes Position Potentiometer:

When initially installed, the Potentiometer should be set so that the feedback voltage, as measured between the wiper (white wire) and common (black wire) is 0.3 to 0.7VDC.

1. Place **COMPRESSOR START/STOP** Switch in the **STOP-RESET (O)** position and wait until the **COASTDOWN** is complete.
2. At the Keypad, log in at **SERVICE** access level using password **1 3 8 0**.
3. Select the **PRV CALIBRATE** Screen from the **COMPRESSOR** Screen.
4. On the **PRV CALIBRATE** Screen, press the **START CALIB** key to initiate the calibration.

The **CALIBRATION IN PROGRESS** LED will illuminate, the PRV opening LED will illuminate and an open signal is applied to the PRV. When the feedback voltage from the PRV potentiometer stops increasing for 25 seconds, the ACC Board assumes this is the full open position and logs this value as 100% open. It then applies a close signal to the PRV and illuminates the PRV Opening LED. When the feedback voltage stops decreasing, the ACC Board assumes this is the fully closed position and logs it as 0% open. These endpoint voltages are stored in the BRAM as the fully closed and fully open positions.

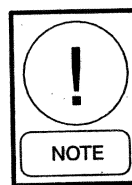

*The calibration procedure can be terminated at any during the procedure by pressing the **CANCEL CALIB** key. If the PRV were previously calibrated successfully, it will revert to using the previous calibration values. If they were not previously calibrated successfully, Variable Speed control will be inhibited and the VSD will operate at fixed speed.*

5. If the difference between the endpoint voltages is not greater than 0.49VDC, or if an endpoint is not detected within 8 minutes, the calibration is considered "unsuccessful".

Setpoints:

The following are the Setpoints and range of programmable values. The Default value is shown in parenthesis. It is the recommended value and should provide proper operation in most applications. Never change these values unless advised by YORK Factory Service.

- a. Surge Margin – 0.0 to 25.0Hz. (0.0)
 - b. Stability Limit – 1000 to 7000 (4500)
1. At the Keypad, log in at **SERVICE** access level using password **1 3 8 0**.
 2. Select **ACC DETAILS** Screen from the **MOTOR** screen.
 3. On the **ACC DETAILS** Screen, press the appropriate Setpoints key above.
 4. Use the numeric keypad keys to enter the desired value.
Press **ENTER** (✓) key.

ACC Surge Map:

To perform any of the following ACC Surge Map functions, proceed as follows:

1. At the Keypad, log in at **SERVICE** access level using password **1 3 8 0**.
2. Select **ACC DETAILS** Screen from the **MOTOR** Screen.
3. On the **ACC DETAILS** Screen, press the appropriate key as follows:
 - a. **Surge Map Clear** – Clears all of the previously established surge points that are stored in memory. When this key is pressed, a dialog box appears requesting the special ACC Map Clear Password. Enter 0 3 6 8 and press the Enter (✓) key. Press switch SW1 on ACC Board within 15 seconds of pressing the Enter (✓) key. A message is displayed advising the clearing is in progress. Another is displayed when clearing is completed. **Important! - This should never be performed unless advised by YORK Factory Service.**
 - b. **Surge Map Print** – Prints the entire array of stored surge points to a printer connected to COM1 Serial Port. Press key again to stop print.
 - c. **Auto Print enable/disable** – Prints new surge points, as they are established, to a printer connected to COM1 Serial Port. Press key again to stop print.
 - d. **Manual Surge Point** – Within 15 seconds of pressing this key, press SW1 on the ACC Board for at least 1 second. The ACC Board will confirm recognition of this point by illuminating red

SURGE LED CR9 for 2 seconds. The operating conditions at that instant are captured and stored as a surge point.

Kilowatt Hours:

1. At the Keypad, log in at **SERVICE** access level using password **1 3 8 0**.
2. Select **MOTOR** Screen.
3. Press **KWH RESET** key.
4. Use numeric keypad keys to enter desired value.
5. Press **ENTER** (✓) key.

VSD Frequency Control:

The VSD Frequency can be manually controlled as follows:

1. At the Keypad, log in at **SERVICE** access level using password **1 3 8 0**.
2. Select **VSD TUNING** Screen from the **COMPRESSOR** Screen.
3. On the **VSD TUNING** Screen, press the appropriate key as follows:
 - a. **Set** – Places Frequency Control in Manual Mode. Sets the VSD speed at a specific frequency between 1.0 and 60 (50) Hz.
 - b. **Auto** – Places the VSD in automatic frequency control. The frequency is determined by the ACC Board to achieve slowest speed possible while avoiding surge.
 - c. **Fixed** – Sets the VSD frequency at maximum: 60 (50) Hz.
 - d. **Raise** – Places Frequency Control in Manual Mode. Increases the VSD frequency by 0.1 to 10.0 Hz, as programmed with the **INCR AMT** (increment amount) key.
Each press of this key increases the frequency by the programmed Amount (0.1 to 10.0Hz)
 - e. **Lower** – Places frequency Control in Manual Mode. Decreases the VSD frequency by ?? to 10.0 Hz, as programmed with the **INCR AMT** (increment amount) key.
Each press of this key decreases the frequency the programmed amount (0.1 to 10.0 Hz).
 - f. **Incr Amt** - Programmable Setpoint (0.1 to 10.0 Hz) that determines the amount of increase or decrease in VSD frequency that occurs with each press of the **INC** or **DEC** key in Manual frequency control mode.

PURGE SYSTEM

A complete description of the Purge System and setpoints that affect its operation is provided in the "Purge System" section of this book. There are two different types of Purge Systems that could be applied. New production chillers are equipped with a pump-assisted High Efficiency system. Earlier chillers, such as those encountered in retrofit applications, are not equipped with a pump and operate at lower pressures. The difference between these systems is the Purge Tank pressure at which the air exhaust valve is opened to release non-condensibles. The appropriate purge type must be enabled to have the purge exhaust occur at the correct pressure.

The Maximum Purges/Hour setpoint determines when the excess purge warning occurs. When the number of air exhausts within an hour equals the programmed value, the warning is displayed.

Purge Type Select:

If the chiller is equipped with the High Efficiency Purge, "Hi Efficiency" operation must be enabled. Otherwise, it must be disabled. Use the following procedure:

1. At the Keypad, log in at **SERVICE** access level, using password **1 3 8 0**.
2. Select **PURGE** screen from **CONDENSER** screen.
3. Use ◀ and ▶ keys to select **ENABLE** or **DISABLE**.
4. Press **ENTER** (✓) key.

Maximum Purges/Hour Setpoint:

The excess purge warning threshold is programmed as the Maximum Purges/Hour setpoint. It is programmable over the range of 1 to 30 (default 20). Proceed as follows to enter this value:

1. At the Keypad, log in at **SERVICE** access level using password **1 3 8 0**.
2. Select **PURGE** screen from the **CONDENSER** screen.
3. Using numeric keypad keys, enter desired value.
4. Press **ENTER** (✓) key.

HOT GAS BYPASS CONTROL

A complete description of the optional Hot Gas Bypass Control and the Setpoints that affect this control are provided in the "Hot Gas Bypass" section of this book.

The Setpoints are listed below. If the chiller is equipped with this feature, it must be "Enabled" and the setpoints programmed using the procedure below. Otherwise, it must be "Disabled". The Hot Gas valve can be manually controlled using the procedure below. The total lifetime Surge Count can be cleared. However, this should **NOT** be arbitrarily performed! Since the Pre-Rotation Vanes (PRV) position is used in the Hot Gas control, the PRV position feedback potentiometer must be calibrated with the procedure below.

Enable/Disable:

If the chiller is equipped with the optional Hot Gas Bypass control, operation must be "enabled". Otherwise, it must be "disabled". Use the following procedure:

1. At the Keypad, log in at **SERVICE** access level, using password **1 3 8 0**.
2. Select **SETPOINTS** Screen. From **SETPOINTS** Screen, select **SETUP** Screen. From **SETUP** Screen, select **OPERATIONS** Screen.
3. Use ◀ and ▶ keys to select Enable or Disable.
4. Press **ENTER** (✓) key.

Setpoints:

The following are the Setpoints and range of programmable values. The **DEFAULT** value is shown in parentheses. The Default value is the recommended value and should provide proper operation in most applications. However, the Setpoint can be programmed to other values to compensate for local operating conditions. Enter Setpoints with procedure below:

- a. Hold Period - 30 to 120 minutes (30)
- b. Close Percentage - 5% to 15% (5%)
- c. Minimum Load - 0°F to 4°F (0°F)
- d. Maximum Open - 25% to 100% (100%)
(Flash Memory Card version C.MLM.02.02.xxx and later)

1. At the Keypad, log in at **SERVICE** access level using password **1 3 8 0**.
2. Select **HOT GAS BYPASS** Screen from the **COMPRESSOR** Screen.
3. On the **HOT GAS BYPASS** Screen, press the appropriate key to select the Setpoint to be programmed.
4. Using the numeric Keypad keys, enter the desired value.
5. Press **ENTER** (✓) key.

Manual Control:

The Hot Gas Valve can be manually controlled as follows:

1. At the Keypad, log in at **SERVICE** access level using password **1 3 8 0**.
2. Select **HOT GAS BYPASS** Screen from the **COMPRESSOR** Screen.
3. On the **HOT GAS BYPASS** Screen, press the **OPEN** or **CLOSE** keys as desired. Each time the key is pressed, the valve position will be increased or decreased 5%. Pressing the **AUTO** key invokes automatic operation.

Pre-rotation Vanes Position Potentiometer Calibration:

1. Place **COMPRESSOR START/STOP** switch in the **STOP-RESET** position (O) and wait until the **SYSTEM COASTDOWN** is complete.
2. At the Keypad, log in at **SERVICE** access level using password **1 3 8 0**.
3. Select the **PRE-ROTATION VANES CALIBRATE** Screen from the **COMPRESSOR** Screen.
4. On the **PRE-ROTATION VANES CALIBRATE** Screen, press the **START CALIBRATION** key to initiate the calibration. The **CALIBRATION IN PROGRESS** and **PRV OPENING LED** will illuminate and an open signal is applied the PRV. When the feedback voltage from the Analog I/O Board, via the RS-485 serial communications link, stops increasing for 25 seconds, the Microboard assumes this is the fully open position and logs this value as the 100% position. It then applies a close signal to the PRV and illuminates the **PRV CLOSING LED**. When the feedback voltage stops decreasing for 25 seconds, the Microboard assumes this is the fully closed position and logs it as the 0% position. These endpoint voltages are stored in BRAM as the fully closed and fully open positions.

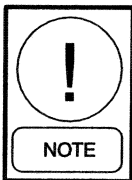

*The calibration can be terminated at any time during the procedure by pressing the **CANCEL CALIB** key. If the PRV were previously calibrated successfully, it will revert to using the previous calibration values. If they were not previously calibrated successfully, they will remain uncalibrated.*

5. If the difference between the endpoint voltages is not greater than 0.49VDC, “**PRV CALIBRATION FAILED**” is displayed on the Hot Gas Bypass Screen.

REFRIGERANT LEVEL CONTROL

(Optional - Flash Memory Card Version C.MLM.02.01.100 or C.MLM.02.01.200 and later versions)

A complete description of the Condenser refrigerant level control and the Setpoints that affect this control are provided in the “Refrigerant Level Control” section of this book. These setpoints are listed below. The Program uses these setpoints to control the refrigerant to the desired level. If the chiller is equipped with this feature, the Program control must be **ENABLED** and the Setpoints programmed using the procedure below.

The refrigerant level can be manually controlled through manual control of the Variable Orifice using the procedure below.

The refrigerant Level Sensor, located in the Condenser, must be properly calibrated to accurately detect the refrigerant level in the Condenser. The procedure below is used to perform this calibration.

Enable/Disable:

If the chiller is equipped with the Refrigerant Level Control, Level control operation must be “Enabled”. Otherwise, it must be “Disabled”. Use following procedure:

1. At the Keypad, log in at **SERVICE** access level, using access code **1 3 8 0**.
2. Select **SETPOINTS** Screen. From **SETPOINTS** Screen select **SETUP** Screen. From **SETUP** Screen select **OPERATIONS** Screen.
3. Use ◀ and ▶ keys to select Enable or Disable.
4. Press **ENTER** (✓) key.

Setpoints:

The following are the Setpoints and range of programmable values. The **DEFAULT** value is shown in parenthesis. The **DEFAULT** value is the recommended value and should provide proper operation in most applications. However, the Setpoint can be programmed to other values to compensate for local operating conditions. Enter Setpoints with procedure below:

- a. Level Setpoint - 20% to 80% (50%)
- b. Level Control Period - 1.0 to 5.0 seconds (3.5)

- c. Proportion Limit Open - 10% to 50% (15%)
 - d. Proportion Limit Close - 10% to 50% (45%)
 - e. Rate Limit Open - 10% to 50% (10%)
 - f. Rate Limit Close - 10% to 50% (10%)
1. At the Keypad, log in at **SERVICE** access Level using access code **1 3 8 0**.
 2. Select **REFRIGERANT LEVEL CONTROL** Screen from the **CONDENSER** Screen.
 3. On the **REFRIGERANT LEVEL CONTROL** Screen, press the appropriate key to select the Set-point to be programmed.
 4. Using the numeric keypad keys, enter desired value.
 5. Press **ENTER** (✓) key.

Manual Control:

The Variable Orifice can be manually controlled as follows:

1. At the Keypad, log in at **SERVICE** access level using access code **1 3 8 0**.
2. Select **REFRIGERANT LEVEL CONTROL** Screen from the **CONDENSER** Screen.
3. On the **REFRIGERANT LEVEL CONTROL** Screen, press the **OPEN**, **CLOSE** or **HOLD** key as required to control the Variable Orifice to achieve the desired refrigerant level. Pressing the **AUTO** key invokes automatic operation.

Level Sensor Calibration:

The refrigerant level displayed on the **CONDENSER** Screen should be 50% when the refrigerant level is midpoint in the Condenser level sensor site glass. If a value other than 50% is displayed, the Refrigerant Level Sensor could be out of calibration. If calibration is necessary, use procedure below (ref. Fig. 49).

1. Remove the Level Sensor cover plate to expose the "S" (span) and "Z" (zero) calibration screws and the output terminal strip. Connect a Voltmeter between terminal 3 (output signal) and 2 (ground).
2. At the Keypad, log in at **SERVICE** access level using access code **1 3 8 0**.
3. At the Keypad, select the **REFRIGERANT LEVEL CONTROL** Screen from the **CONDENSER** Screen.
4. Shutdown the chiller. After the Pre-rotation Vanes have fully closed and the Vane End Switch has closed, the Variable Orifice will be driven to the fully open position, causing the refrigerant level in the Condenser to be at minimum. With the orifice fully open, adjust the Level Sensor "Z" (zero)

calibration screw until the Level Sensor output voltage is 0.05VDC.

5. Start the chiller and use the **OPEN**, **CLOSE** and **HOLD** keypad keys, as required, to manually control the Variable Orifice to place the Condenser refrigerant level at the midpoint of the site glass. With the refrigerant at this level, adjust the Level Sensor "S" (span) calibration screw until the Level Sensor output voltage is 2.5VDC.

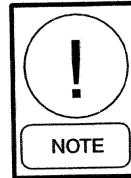

Due to turbulence in the Condenser, it could be difficult to maintain the level at the midpoint of the sight glass. Therefore, the calibration should be performed with the level as close to the midpoint as can be achieved.

6. Seal the calibration screws with a small amount of sealant.
7. Replace Level Sensor cover plate.

HIGH CONDENSER PRESSURE WARNING THRESHOLD

The condenser pressure at which a High Pressure warning message is displayed and the Pre-rotation Vanes are inhibited from further opening, is programmable over the range of 14.0 to 28.8 PSIA. The Default value is 28.8 PSIA. The Warning message will clear and the PRV inhibit is removed when the pressure decreases to 0.1 PSIA below the programmed value. Proceed as follows to enter this value:

1. At the Keypad, log in at **SERVICE** access level using password **1 3 8 0**.
2. Select **CONDENSER** Screen.
3. On the Condenser Screen, press **HIGH PRESSURE WARNING THRESHOLD** key.
4. Using numeric keypad keys, enter desired value.
5. Press **ENTER** (✓) key.

BRINE LOW EVAPORATOR PRESSURE CUTOUT

On Brine cooling applications, the Low Evaporator Pressure safety shutdown threshold is programmable over the range of 0.0 to 12.5 PSIA. The Default value is 12.5 PSIA. The actual percentage of Brine solution determines this threshold. It is calculated at the YORK Factory and programmed at the time of manufacture. If the BRAM memory device on the Microboard is replaced, the threshold will have to be programmed in

the field. The threshold is logged on an adhesive label attached to the inside of the Control Center door. Proceed as follows to enter this value:

1. At the Keypad, log in at **SERVICE** access level using password **1 3 8 0**.
2. Select **EVAPORATOR** Screen.
3. On the **EVAPORATOR** Screen, press the **BRINE LOW EVAPORATOR CUTOUT** key.
4. Using numeric keypad keys, enter desired value.
5. Press **ENTER** (✓) key.

LEAVING CHILLED LIQUID TEMPERATURE CONTROL SENSITIVITY

This Setpoint adjusts the Leaving Chilled Liquid Temperature control sensitivity. It determines the magnitude of Pre-rotation Vanes (PRV) response to correct the error between the Leaving Chilled Liquid Temperature Setpoint and the actual liquid temperature leaving the chiller. There are two selections as follows:

NORMAL - Provides standard control operation. PRV open and close pulses are standard durations for any given error. Longest allowed pulse is 18 seconds in duration. This selection will provide proper operation in most applications.

50% - Provides decreased sensitivity. Each PRV open and close pulse is 50% shorter in duration than the standard response. Also, the longest allowed pulse is limited to 7 seconds. This reduces the overall amount of PRV movement. This selection will reduce PRV instability in short chilled liquid loops, multi-pass chillers, parallel chiller configurations and other applications that cause PRV instability.

Proceed as follows to select this value:

1. At the Keypad, log in at **SERVICE** access level using password **1 3 8 0**.
2. Select **EVAPORATOR** Screen.
3. Press **SENSITIVITY** key.
4. Use ◀ and ▶ keys to select desired value.
5. Press **ENTER** (✓) key.

DROP LEG REFRIGERANT TEMPERATURE

The chiller can be equipped with a refrigerant temperature sensor in the drop leg between the condenser and evaporator. If "Enabled" with the procedure below, this temperature is displayed on the **CONDENSER** Screen

as the "Drop Leg Temperature". It is subtracted from the Condenser Saturation Temperature to produce "Sub Cooling Temperature", also displayed on the Condenser Screen. If the chiller is equipped with the Drop Leg Refrigerant Temperature sensor, the values are displayed on the **CONDENSER** Screen only if enabled with the following procedure.

1. At the Keypad, log in at **SERVICE** access Level using password **1 3 8 0**.
2. Select **CONDENSER** Screen.
3. Press **DROP LEG** key.
4. Use ◀ and ▶ keys to select Enable or Disable.
5. Press **ENTER** (✓) key.

SMART FREEZE PROTECTION

This feature is described in the "Smart Freeze Protection" section of this book. When turned on, it allows the Leaving Chilled Liquid Temperature Setpoint to be as low as 36°F for water cooling applications. Along with this feature is a correspondingly lower Low Water Temperature Cycling Shutdown threshold and Low Evaporator Pressure Safety Shutdown threshold. The Smart Freeze Protection feature can be turned **ON** or **OFF** using the following procedure:

1. Shut down the chiller and wait for completion of **COASTDOWN**.
2. At the Keypad, log in at **SERVICE** access level using password **1 3 8 0**.
3. Select **EVAPORATOR** Screen.
4. Press **SMART FREEZE** key.
5. Use ◀ and ▶ keys to select **ON** or **OFF**.
6. Press **ENTER** (✓) key.

EVAPORATOR REFRIGERANT TEMPERATURE

If the chiller is equipped with an Evaporator Refrigerant Temperature sensor, the feature must be Enabled with the procedure below. If not equipped with this sensor, it must be Disabled. If enabled, this temperature is displayed on the **EVAPORATOR** Screen, and is also used in the **Smart Freeze** protection Low Evaporator Pressure Safety Shutdown threshold calculation, as explained in the "Smart Freeze Protection" section of this book.

Use the following procedure to Enable or Disable this feature:

1. At the keypad, log in at **SERVICE** access level using password **1 3 8 0**.
2. Select **EVAPORATOR** Screen.
3. Press **REFRIGERANT** key.

4. Use ◀ and ▶ keys to select Enabled or Disabled.
5. Press ENTER (✓) key.

SERVICE PHONE NUMBERS

(Flash Memory card version C.MLM.02.02.xxx and later)

Two service phone numbers (Regional and Local), with labels, can be displayed on the OPERATIONS Screen. The Default value for the Regional number is the "North American Toll Free Number" (1-800-861-1001). However, the label and number can be changed to any desired value. The Default value for the Local label and number is blank. The Service Technician enters the Local phone number and label.

The entry format consists of 4 fields (rows), vertically from the top. Up to 40 characters/numbers can be entered for each field.

Field 1 – Regional phone number label. Default value

Field 2 – Regional phone number. Default value is 1-800-861-1001.

Field 3 – Local service phone number label. Default value is blank.

Field 4 – Local service phone number. Default value is blank.

Use the following procedure to change any of the fields:

1. At the Keypad, login at **SERVICE** access level using access code **1 3 8 0**.
2. Select **OPERATIONS** Screen.
3. Press **EDIT PHONE NUMBERS** Key.
4. Use ▲ and ▼ keys to move green selection box to the desired field to be changed.
5. Press the **ENTER (✓)** key.
6. In the Dialog box that appears, a red box appears over the first changeable value. Use the ▲ and ▼ keys to position the red box over the number/character to be changed or entered. Use the ▲ and ▼ keys to scroll sequentially through numbers, alphabet characters and punctuation marks to select the desired value. When the desired value displayed, use the ◀ and ▶ keys to move the red box to the next value to be changed. The numeric keypad keys can also be used to enter numbers. Continue this process until all desired values have been entered.
7. After all desired values have been entered in previous step, press **ENTER (✓)** key.

SURGE PROTECTION

(Flash Memory Card version C.MLM.02.02.xxx and later)

A complete description of the Surge Protection feature and setpoints that affect this control are provided in the "Surge Protection" section of this book. Although most setpoints are entered with Operator access level, the Surge Sensitivity setpoint and Total Surge Count clearing require Service access level or higher.

Surge Sensitivity:

1. At the keypad, log in at **SERVICE** access level, using **1 3 8 0**.
2. Select **SURGE PROTECTION** Screen from **COMPRESSOR** Screen.
3. Press **SURGE SENSITIVITY** key.
4. Using numeric and decimal point keypad keys, enter desired Value. Programmable over range of 0.3 to 1.3. Default value is 0.3. Use leading zeroes where necessary and place decimal point between first and second digit (ie; 0.3, 1.2, etc.)
5. Press **ENTER (✓)** key.

Clear Surge Count:



This should not be arbitrarily performed.

1. At the keypad, log in at **ADMIN** access level. Obtain **ADMIN** password from local service office. This password changes daily.
2. Select **SURGE PROTECTION** Screen from **COMPRESSOR** Screen.
3. Press **CLEAR SURGE COUNT** key.

CHILLER STARTS AND OPERATING HOURS RESET

The Number of Starts and the Operating Hours can be reset to zero or preset to a desired number. However, this should never be arbitrarily performed. Use the following procedure:

1. At the keypad, login at **ADMIN** access level. This password changes daily. Contact your local YORK Service Office.
2. Select **OPERATIONS** screen.
3. Press **NUMBER of STARTS** or **OPERATING HOURS** key as appropriate.

4. Using numeric keypad keys, enter desired number.
5. Press **ENTER** key (✓) key.

SALES ORDER DATA

All of the Sales Order Data, except the "Chiller Commissioning Date" is entered at the YORK Factory at the time of chiller manufacture. The Service Technician must enter the Chiller Commissioning Date and modify the Job Name or Job Location if necessary at the completion of commissioning. Normally, the remainder of the Sales Order Data should never be modified. However, if there is a change to the chiller design, in the field, this data can be modified. If the BRAM battery-backed memory device (U52) fails and requires field replacement, all of the data will be lost and will have to be manually programmed.

There are three different Passwords used, depending on the circumstances, to change the Sales Order Data as follows:

- **Chiller Commissioning** - Service Technician must use password **1 3 8 0** to enter the Commissioning Date and modify Job Name and Job Location if necessary.
- **Modifying Sales Order Data** - Service Technician must use the **ADMIN** password. This password changes daily. Contact your local YORK Service Office.
- **BRAM Replacement** - If the BRAM (U52) is field replaced, the Service Technician must use password **0 2 2 8** to enter all Sales Order Data into a new blank BRAM. When logged in at this level, the **ACCESS LEVEL** shown will be **TEST OP**. This password **only** works with a blank BRAM.



*When using this password to enter data into a new blank BRAM, the **FINISH PANEL SETUP** procedure (listed at the end of the entry procedure below) must be performed after all data has been entered. Failure to perform this procedure will result in unreliable Control Center operation! If this procedure is performed prior to entering all data, the ability to enter more data will be terminated.*

Use the following procedure to enter data:

1. At the keypad, log in using the appropriate password as described above.

2. From the **SETPOINTS** Screen, select **SETUP SCREEN**. From the **SETUP** Screen, select **SALES ORDER** Screen.
3. If logged in at **SERVICE** Access level, press **SET ORDER INFO** key to enter Commissioning date, Job Name or Location and proceed to step 4. If logged in at **ADMIN** level, Press **SELECT** key to select the data category (**ORDER**, **DESIGN**, **NAMEPLATE**, **SYSTEM**) to be entered.
4. Press **CHANGE** key. The first changeable area in the selected category will be outlined in a green selection box. The procedure can be terminated anytime after this by pressing the **CANCEL (X)** key.
4. Use the **▲** and **▼** keys to move the green selection box to the desired value to be changed, within the category selected.
5. Press **ENTER (✓)** key.
6. Enter the appropriate data. Use the numeric keypad keys to enter numbers. Use the **•** key to enter a decimal point. Use the **▲** and **▼** keys to scroll sequentially up and down through the alphabet to enter letters or a comma (,), slash (/) or minus sign (-). Each time the **▲** key is pressed, the next higher sequential alphabet letter is displayed. Each time the **▼** key is pressed, the next lower alphabet letter is displayed. The comma, slash and minus sign can be selected after scrolling through the entire alphabet. During the entry process, the **▶** key can be used to backspace and the **◀** key can be used to forward space.
7. Press **ENTER (✓)** key.
8. Use **▲** and **▼** keys to select another value to be changed within the same category or press **CANCEL (X)** key to exit and allow selection of another category.
9. **EXTREMELY IMPORTANT!** If the procedure above was performed using password **0 2 2 8** to enter data into a new blank BRAM, the following procedure must be performed after all the desired data is entered. If the following procedure is performed prior to entering all of the data, the ability to enter more data will be terminated. Failure to perform this procedure after all data has been entered will result in unreliable Control Center Operation!
 - a. On **SALES ORDER** screen, press **FINISH PANEL SETUP** key.

- b. Use ◀ or ▶ key to select YES.
- c. Press ENTER (✓) key.

CUSTOM USER ID AND PASSWORDS

When logging in, the user is requested to enter a **User ID**, followed by a **Password**. The universal and Default **User ID** is zero (0). The universal **Password** to log in at **OPERATOR** access level is **9 6 7 5**. The universal **Password** to log in at **SERVICE** access level is **1 3 8 0**. No log in is required for **VIEW** access level. However, if desired, the service technician can establish up to four custom **User ID**'s and **Passwords** that can be used by Operations personnel to log in at **VIEW**, **OPERATOR**, or **SERVICE** level.

Up to four Custom Users can be established with **User ID**'s from 1 to 9999. Each user can be assigned a **Password** of 0 to 9999 and an access level of **VIEW**, **OPERATOR** or **SERVICE**.

Use the following procedure to establish Custom Users:

1. At the Keypad, log in at **SERVICE** access level using **1 3 8 0**.
2. From the **SETPOINTS** Screen, select **SETUP** Screen. From **SETUP** Screen, select **USER** Screen.
3. Press **CHANGE USER ATTRIBUTES** key. The first changeable area is outlined in a green selection box.
4. Use the ◀, ▶, ▲ or ▼ keys to move the green selection box to the desired value to be changed.
5. Press the **ENTER** (✓) key.
6. Using numeric Keypad keys, enter desired parameter as follows:
User ID – 1 to 9999 (numbers cannot be duplicated for more than one user)
Password – 0 to 9999
Access Level – 0 = View, 1 = Operator, 2 = Service
7. Press **ENTER** (✓) key.
8. After all values have been entered, press **CANCEL** key (X) to exit.

SECTION 23

DIAGNOSTICS & TROUBLESHOOTING

(REFER TO FIG. 61 - 68)

The problems that could be encountered in the Control Center are in the following categories:

- Keypad
- Display
- Serial Input/Output (I/O)
- Digital Input/Output (I/O)
- Analog Inputs

There is a Diagnostic and associated Troubleshooting procedure for each category. They are described on the following pages. Each Diagnostic is accessed from the Diagnostics Main Screen, which is entered using the procedure below. If there is a Control Center problem, determine the category of the problem. Then perform the applicable Diagnostic. If the Diagnostic reveals a malfunction, perform the Troubleshooting procedure to locate the defective component.

There are several documents that must be referred to while performing the Diagnostics and Troubleshooting procedures. Each procedure references the Section and figures of this book that describe the operation of the component being tested. Also, the applicable Control Center wiring diagram must be used as follows: 160.55-PW1 (Electro-Mechanical Starter), 160.55-PW2 (Mod "B" Solid State Starter) or 160.55-PW3 (Variable Speed Drive).

There are two versions of the Diagnostics screens available as follows:

1. Shown in figures 61 through 68. These screens are used during the Diagnostics and Troubleshooting process. They allow output states to be changed. Access the **DIAGNOSTICS** Main Screen as follows:

1. The chiller must be stopped.
2. Place **COMPRESSOR START/STOP** switch in the **STOP-RESET** position (O).
3. Ensure the Compressor motor current is 0% FLA.
4. Log in at **SERVICE** access level using password **1 3 8 0**.
5. Move Microboard Program Switch SW1-4 to the **ON** position. A Watchdog reset will occur and the Boot-up process will commence. At the completion of the Boot-up process, the **DIAGNOSTICS** Main Screen will appear. (Note: If SW1-4 is moved to the **ON** position before step 4 above is performed, the **LOG IN** key will be displayed and Logging in at **SERVICE** access level must be performed before the Main Screen is displayed.
2. Not shown. Available when logged in at **SERVICE** access level, whether the chiller is running or not. Accessed from the **SETUP** screen via the **SETPOINTS** screen. There are two screens available that allow the Analog Inputs voltage levels and Digital I/O states to be monitored. These screens are preceded by a general screen that provides the installed software versions.

SOFTWARE VERSION

Controls - FLASH Memory Card on Microboard

BIOS - BIOS Eprom on Microboard

Kernel - Software that is part of FLASH Memory Card

GUI - Software that is part of FLASH Memory Card

SIO - Software that is part of FLASH Memory Card

GPIC - Eprom in MicroGateway

MAIN DIAGNOSTICS SCREEN

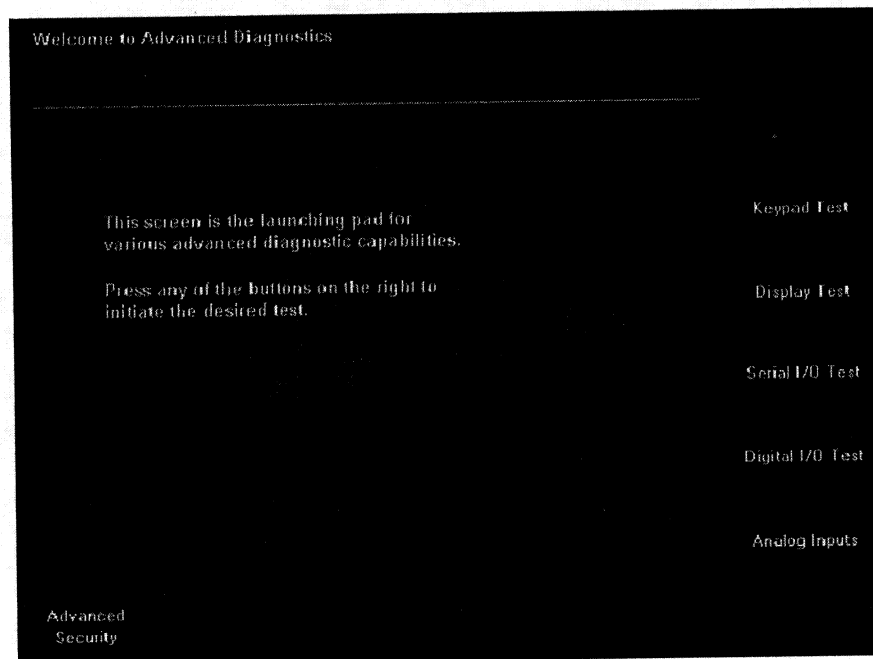

FIG. 61- MAIN DIAGNOSTICS SCREEN

00379VIP

23

Each of the Diagnostics is accessed from this screen. Press the appropriate key to select the desired diagnostic. After each diagnostic is performed, return to this **MAIN** Screen, from which the next diagnostic can be selected.

Some of the diagnostics have sub-screens that are accessed from the selected diagnostic screen. The sub-screens are shown indented below:

Main screen

- Keypad test
- Display test
 - Bit patterns test
 - All red
 - All green
 - All blue
 - All white
 - All black
- Serial I/O test
- Digital I/O test
- Analog Inputs

The **ADVANCED SECURITY** key is used during the manufacturing process and has no field service use.

KEYPAD TEST

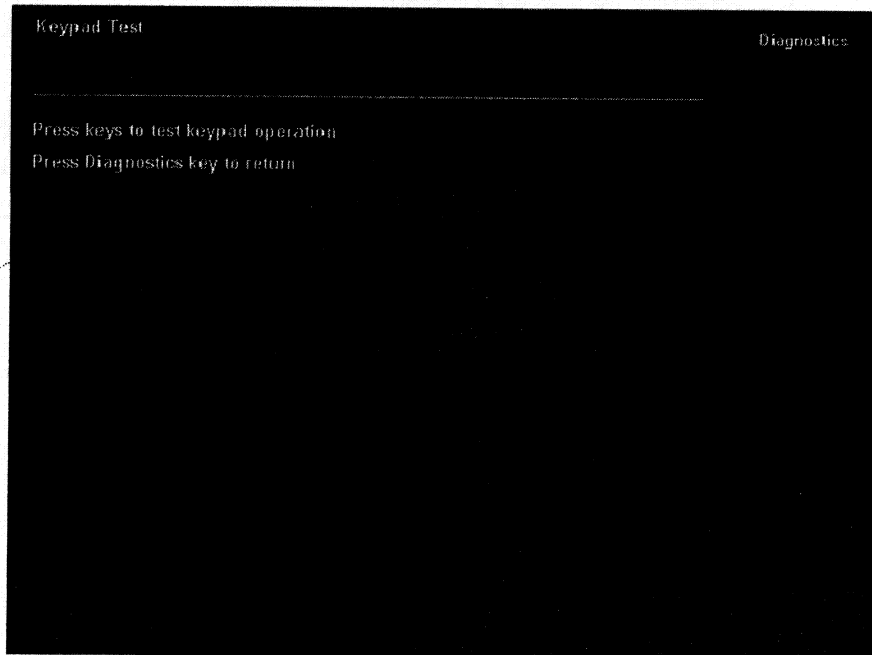

FIG. 62 – KEYPAD TEST SCREEN

00380VIP

This diagnostic is used to verify Keypad operation and the Microboard's ability to respond to a pressed key. Refer to description of Keypad operation in Section 8 of this book.

PROCEDURE

1. Press each keypad key. As the key is pressed, an illuminated LED is displayed corresponding to the key location on the keypad.
2. Press the **DIAGNOSTICS** key to return to the **MAIN DIAGNOSTICS** Screen.

TROUBLESHOOTING

If an LED is not displayed when a key is pressed, the Keypad, Keypad ribbon cable or Microboard could be defective. Use the following procedure to locate the defective component.

1. **Keypad**

- a. Disconnect the ribbon cable from the Keypad.

- b. Identify row/column coordinate of the key to be tested. Refer to Figure 33.

- c. In the Keypad connector, locate the pins of the row/column coordinate of the key of the key to be tested.

- d. Insert the leads of an Ohmmeter into the pins identified in step "c" above.

- e. Press the key to be tested. If the contact resistance is >100 Ohms, the Keypad is defective.

- f. Release the key. If the contact resistance is < 1 Meg Ohm, the Keypad is defective.

2. **Ribbon Cable**

Using an Ohmmeter, perform a continuity test on all conductors in the ribbon cable. An open circuit would indicate the ribbon Cable is defective.

3. **Microboard**

There are no checks or measurements to be made on the Microboard. If the Keypad and Ribbon Cable check OK per the above procedures, the Microboard is most likely the cause of the problem.

DISPLAY TEST

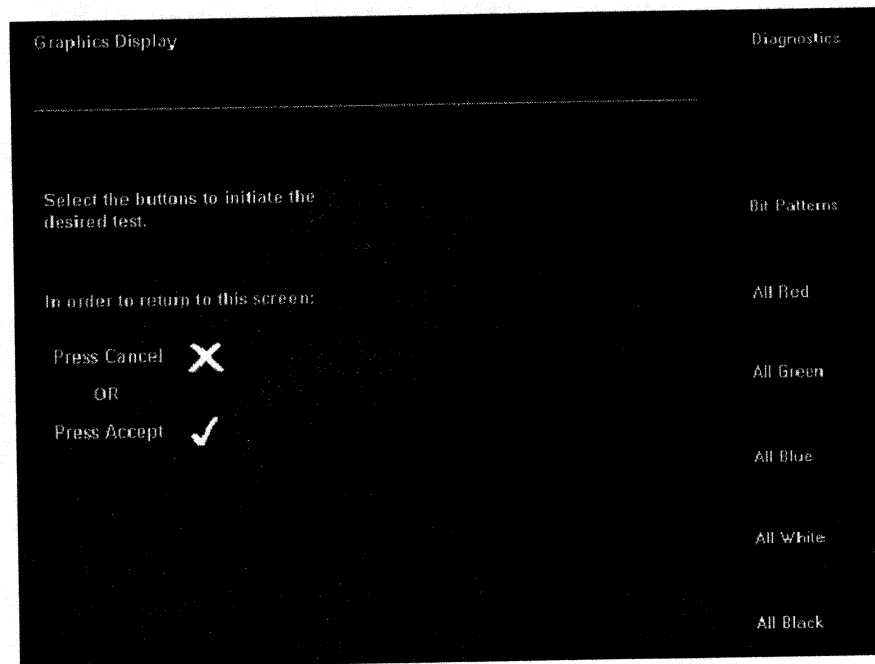

FIG. 63 – DISPLAY TEST MAIN SCREEN

Each of the Display Diagnostics is accessed from this screen. After each diagnostic is performed, return to this screen, from which the next diagnostic can be selected. Refer to description of Display operation in Sections 5 through 7 of this book.

PROCEDURE

1. Press the appropriate keypad key to perform the desired test from the list below.
 2. Press the **CANCEL (X)** or **ENTER (✓)** key to terminate test and return to **DISPLAY TEST MAIN SCREEN**, from which another test can be selected.
 3. When all the desired tests have been performed, press the **DIAGNOSTICS** key to return to the **MAIN DIAGNOSTICS SCREEN**.
- **Bit Patterns** - This test is used to detect jitter and alignment defects. It verifies proper operation and compatibility of the Microboard Display Controller with the display. Four vertical bars of green, dark blue, light blue and yellow, outlined by a red border are displayed. If the vertical bars are not stable or straight, or the red border is not completely visible, then either the Microboard Program Jumpers are not configured correctly for the installed display or the Microboard Display controller is defective. Refer to Fig. 64.
 - **All Red** - This test verifies the operation of all of the red pixels. All of the red pixels are turned on to create a completely red screen. Any red pixels that do not turn on will appear as black dots on the display. If any black dots appear, first ascertain it is not caused by dirt that is lodged between the display surface and the protective plastic cover. It is normal for a small number of randomly spaced pixels to not illuminate. It is not necessary to replace the display if a small number of black dots appear. They will not be visible on the normal screens displayed outside of this diagnostic mode. However, large black areas would be indicative of a defective display.
 - **All Green** - This test verifies the operation of all of the green pixels. All of the green pixels are turned on to create a completely green screen. Refer to description of "All Red" test above.
 - **All Blue** - This test verifies the operation of all of the blue pixels. All of the blue pixels are turned on to create a completely blue screen. Refer to description of "All Red" test above.
 - **All White** - This test verifies the display's ability to turn on all pixels to display a completely white screen. Any pixel that does not turn on will appear as a black dot. Refer to description of "All Red" test above.
 - **All Black** - This test verifies the display's ability to turn off all pixels to display a completely black screen. Any pixel that does not turn off will appear as a red, green, blue or white dot. Refer to description "All Red" test above.

BIT PATTERNS TEST

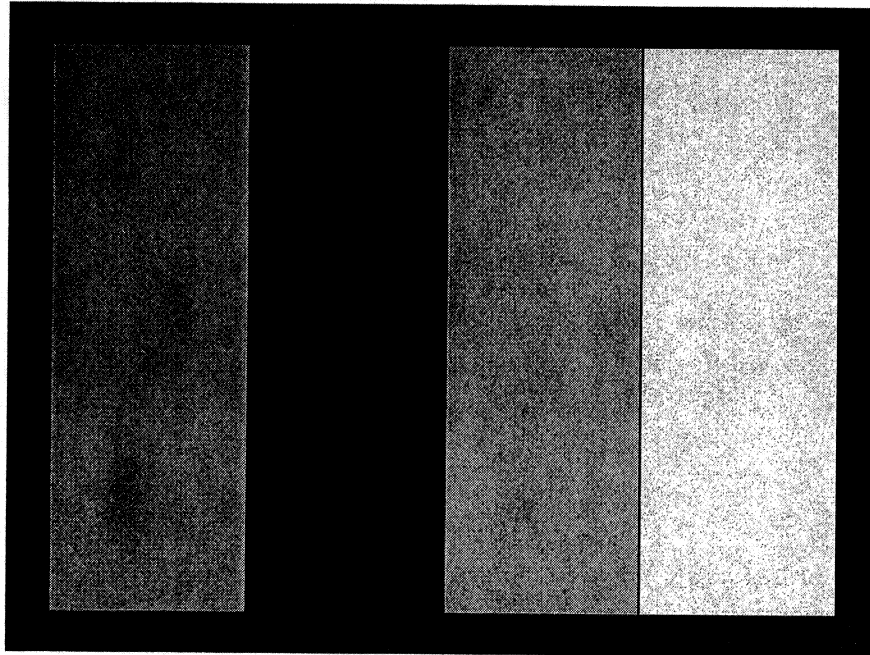

FIG. 64 – BIT PATTERNS TEST SCREEN

00382VIP

TROUBLESHOOTING

If any of the above tests do not perform correctly as described above, perform the applicable procedure below:

Test Failed:

Bit Patterns - If the vertical bars are not straight or if the red border is not completely visible, either the Microboard Program Jumpers are not configured correctly or for the installed Display or the Microboard is defective.

All Red, All Green, All Blue, All White or All Black:

If these tests do not produce appropriate solid color screens, the Display Ribbon Cable, Display Interface Board, Microboard or Display could be defective. To locate the defective component perform tests in the following order:

1. **Display Ribbon Cable:**

Using an Ohmmeter, perform a continuity test on all conductors in the ribbon cable. An open circuit would indicate the ribbon cable is defective.

2. **Display Interface Board:**

Using an Ohmmeter, perform a continuity test on all conductors of the Interface Board. An open circuit would indicate the Interface Board is defective.

3. **Microboard:**

- a. With the "All Red" test selected, the voltage at

Microboard J5-6 through J5-11 (Red drivers bits 0-5), as measured to Gnd, should be $> 3.0\text{VDC}$. If not, the Microboard is defective.

- b. With the "All Green" test selected, the voltage at Microboard J5-13 through J5-18 (Green drivers bits 0-5), as measured to Gnd, should be $> 3.0\text{VDC}$. If not, the Microboard is defective.

- c. With the "All Blue" test selected, the voltage at Microboard J5-20 through J5-25 (Blue drivers bits 0-5), as measured to Grid, should be $> 3.0\text{VDC}$. If not, the Microboard is defective.

- d. With the "All White" test selected, the voltage at Microboard J5-6 through J5-11, J5-13 through J5-18 and J5-20 through J5-25 should be $> 3.0\text{VDC}$. If not, the Microboard is defective.

- e. With the "All Black" test selected, the voltage at Microboard J5-6 through J5-11, J5-13 through J5-18 and J5-20 through J5-25 should be $< 1.0\text{VDC}$. If not, the Microboard is defective.

4. **Display:**

If the Display Ribbon Cable, Display Interface Board and Microboard check OK per the above procedures, the Display is most likely the cause of the problem.

SERIAL INPUTS / OUTPUTS TESTS

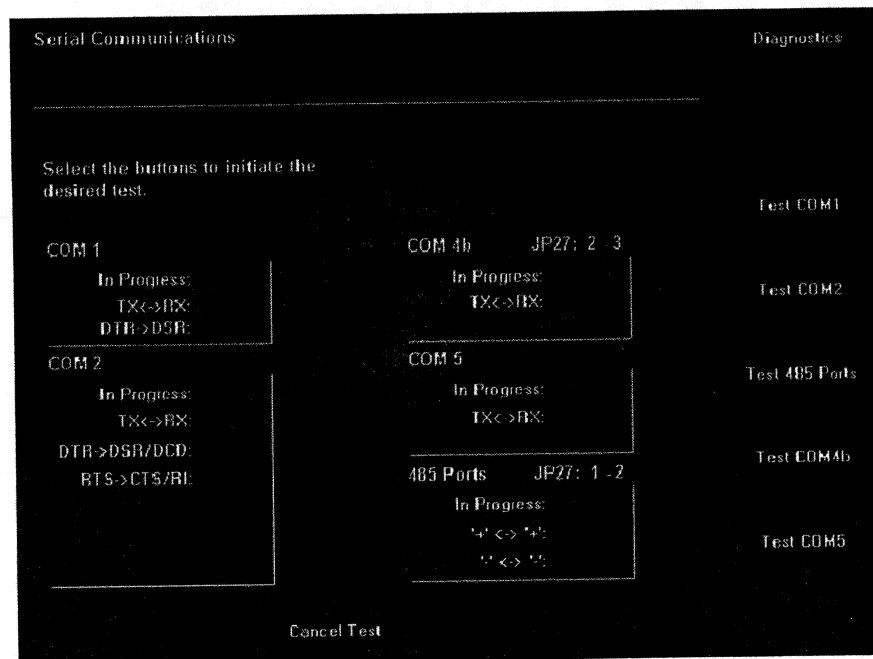

FIG. 65 – SERIAL INPUTS / OUTPUTS TEST SCREEN

00383VIP

23

This diagnostic is used to verify correct operation of the Serial Data Ports. There is a test for each of the five Serial Data Ports. Each RS-232 port (COM 1, 2 and 4b) is tested by transmitting serial test data from outputs to inputs of each port. Both the transmit and receive functions as well as the control lines are tested. The RS-485 ports (COM 3 and 4a) are tested by transmitting serial test data from one RS-485 port to another. The TX/RX opto-coupled port (COM 5) is tested by transmitting serial test data from the TX output to the RX input. If the received data matches the transmitted data, PASS is displayed, indicating the serial port is OK. Otherwise, FAIL is displayed, indicating the serial port is defective. Prior to performing each test, the Service Technician must install a wire loop-back connection as described below. Refer to Section 3 and Figure 10 of this book for description of the Serial data Ports.

PROCEDURE

- Using small gauge wire, fabricate loop-back connections and install as follows for each port to be tested. Failure to install the loop-back connection or configure the Microboard Program jumper as noted will result in a FAIL outcome for the test.

	From	To
COM 1	J2-4 (TX) J2-5 (DTR)	J2-3 (RX) J2-2 (DSR)

	From	To
COM 2	J13-5 (TX) J13-7 (DTR) J13-4 (RTS)	J13-3 (RX) J13-1(DCD) & J13-2 (DSR) J13-6 (CTS) & J13-8 (RI)

	From	To
RS-485 (COM 3 & 4a)	J12-3 (+) J12-2 (-)	J11-3 (+) J11-2 (-)

Microboard Program Jumper JP27 must be installed in position 1 & 2.

	From	To
COM 4b	J2-7 (GTX)	J2-6 (GRX)

Microboard Program Jumper JP27 must be installed in position 2 & 3.

	From	To
COM 5	J15-1 (TX) J15-2 (RX) J15-3 (Common)	J15-4 J15-5 J15-6

Make individual wire connections or use YORK loop-around diagnostic connector 025-33778-000 as depicted in Figure 66. This connector is available from the YORK Parts Distribution Center.

2. After connecting appropriate loop-back connections above, press the appropriate key to initiate the desired test. An LED will illuminate indicating the test is in progress. If it is desired to terminate the test, press the **CANCEL TEST** key. Test data is sent from an output to an input as described below. At the completion of each test, if the data received matches the data sent, the Serial Port operates properly and **PASS** is displayed. Otherwise, **FAIL** is displayed, indicating the Serial Port is defective. A **FAIL** result would be indicative of a defective Microboard. The following is a description of each test.

COM 1 – Two tests are performed. Test data is sent from TX (J2-4) to RX (J2-3) at 9600 Baud and DTR (J2-5) is set to a Logic High level and read at DSR (J2-2). If any test fails, COM 1 tests are terminated.

COM 2 – Three tests are performed. Test data is sent from TX (J13-5) to RX (J13-3) at 19200 Baud.

DTR (J13-7) is set to a Logic High and read at DSR (J13-2) & DCD (J13-1). RTS (J13-4) is set to a Logic High and read at CTS (J13-6) & R1 (J13-8). If any test fails, COM 2 tests are terminated.

RS-485 (COM 3 & 4a) – Test data is sent from COM 3 RS-485 port to COM 4a RS-485 Port at 19200 Baud. Test data is then sent from COM 4a to COM 3 at the same rate. If either test fails, RS-485 tests are terminated.

COM 4b – Test data is sent from GTX (J2-7) to GRX (J2-6) at 19200 Baud.

COM 5 – Test data is sent from TX (J15-1) to J15-4 at 1200 Baud. This output turns the Microboard's loop-around test Transistor on and off, applying 0/+5VDC pulses from J15-5 to RX (J15-2) input.

3. After all desired tests have been performed, press the **DIAGNOSTICS** key to return to the **MAIN DIAGNOSTICS** Screen.

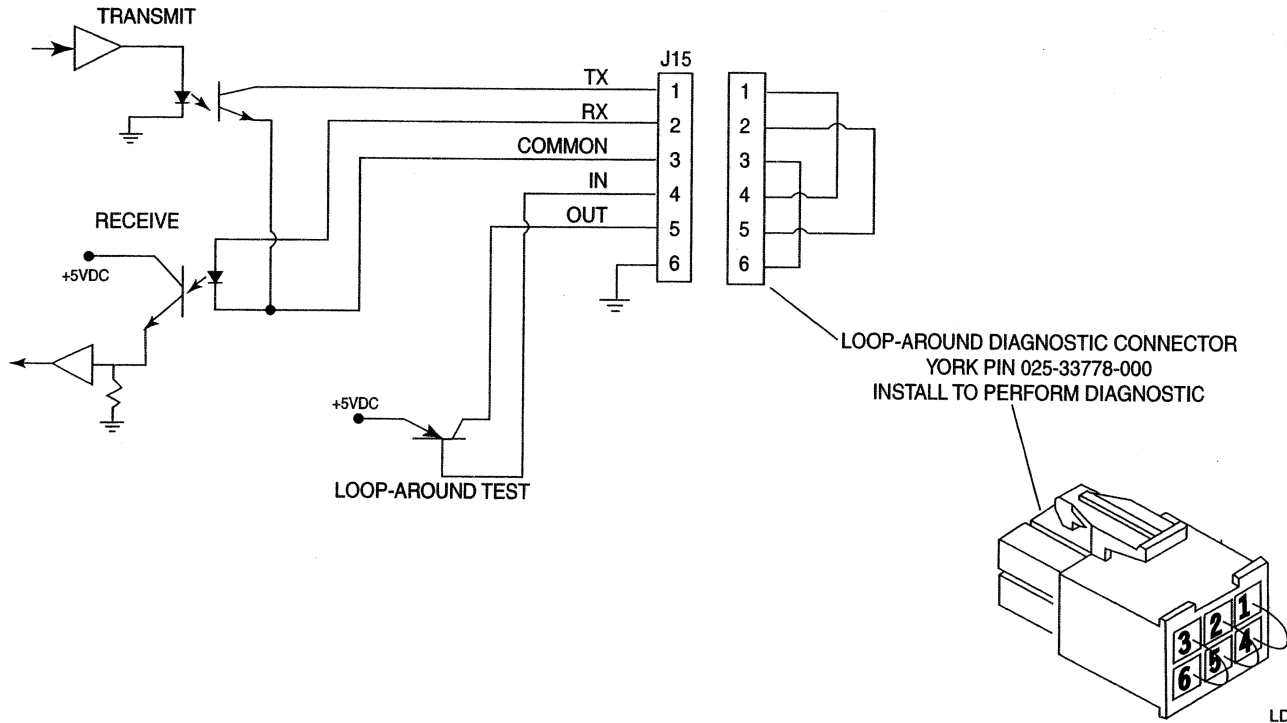

LD04250

FIG. 66 – MICROBOARD - COM 5 SERIAL DATA PORT

DIGITAL INPUTS / OUTPUTS TESTS

Digital Inputs		Digital Outputs		Diagnostics
TB#: 35	JP37	K0	K12	Use the arrow keys to select the desired Digital Output channel.
TB#: 32	JP36	K1	K13	
TB#: 11	JP35	K2	K14, K17	Use the keys below to Enable or Disable the selected output.
TB#: 31	JP34	K3	K15	
TB#: 9	TB#: 28	K4	K16	Select Output
TB#: 13	TB#: 30	K5	Q1	
TB#: 12	TB#: J2-1	K6	Q2	Enable Output
TB#: 20	TB#: 32	K7	Q3	
TB#: 19	DIP 1	K8	Q4	Disable Output
TB#: 8	DIP 2	K9	Q5	
TB#: 7	DIP 3	K10	Q6	
TB#: 31	DIP 4	K11	J20-3	
TB#: 30	DIP 5			
TB#: 18	DIP 6			
TB#: 70	DIP 7			
TB#: 71	DIP 8			
	JP39			

00384VIP

FIG. 67 – DIGITAL INPUTS / OUTPUTS TEST SCREEN

This diagnostic is used to analyze the digital inputs and outputs of the Microboard. Refer to description of I/O Board in Section 4 of this book.

The state of each Microboard Digital Input, Program Jumper and Program DIP Switch, as interpreted by the Microboard, is depicted by an LED. If the Microboard interprets its input as being at a Logic Low (<1.0VDC) level, the LED is illuminated. If interpreted as being at a Logic High (>4.0VDC) level, the LED is extinguished.

The state of the Microboard's intended drive signals to each of the Relays on the I/O Board is depicted by an LED. If the intended output is a Logic Low level (<1.0VDC), the LED is illuminated. If the intended output is a Logic High level (>10.0VDC), the LED is extinguished. Logic Low outputs energize the Relays. Logic High outputs de-energize the Relays. The state of any output can be manually set to either the ENABLED (Logic Low) or DISABLED (Logic High) state.

PROCEDURE

Digital Inputs:

1. The Digital Inputs are listed on this screen according to a.) Terminal number on the I/O Board and b.) Microboard Program Jumpers and Program DIP Switches. Figure 13 shows the devices connected

to these terminals. Tables 1 and 2 list the functions of the Program Jumpers and Switches.

2. With 115VAC applied to a particular I/O Board Digital Input, the applicable LED should be illuminated. If the LED is not illuminated, perform appropriate Troubleshooting procedure below.
3. With 0VAC applied to a particular I/O Board Digital Input, the applicable LED should be extinguished. If the LED is not extinguished, perform appropriate Troubleshooting procedure below.
4. If a Program Jumper is present, the applicable LED should be extinguished. If the LED is not extinguished, the Microboard is defective.
5. If a Program Jumper is not present, the applicable LED should be illuminated. If the LED is not illuminated, the Microboard is defective.
6. If a Program Switch (DIP) is in the ON position, the applicable LED should be illuminated. If the LED is not illuminated, the Microboard is defective.
7. If the Program Switch (DIP) is in the OFF position, the applicable LED should be extinguished. If the LED is not extinguished, the Microboard is defective.
8. When all desired tests have been performed, press **DIAGNOSTICS** key to return to **MAIN DIAGNOSTICS** Screen.

Digital Outputs:

1. **IMPORTANT!** - The following steps cannot be performed until the Motor Controller connection between TB6-1 and TB6-53 has been removed. This connection could be a jumper or it could be a connection from external devices in the starter. The Program will prevent manual control of Digital Output devices until this connection is removed.
2. The Digital Outputs are listed on this Screen according to Relay and Triac number (KI, Q3, etc.). Figure 16 shows the external devices that are connected to these Relays and Triacs and the functions of each one.
3. Press **SELECT** key. An arrow will appear adjacent to Relay KO.
4. Select a relay or triac for manual control by using the **▲** and **▼** keys to place the arrow adjacent to the desired device.
5. Press the **ENABLE OUTPUT** key to enable the selected output. The LED adjacent to the selected output should illuminate. If it does not, perform **KEYPAD** Diagnostics test. If a relay is selected, it should energize, closing its contacts. If a triac is selected, it will turn on, energizing the device it is connected to. If the relay does not energize or triac does not turn on, perform appropriate troubleshooting procedure below.
6. Press the **DISABLE OUTPUT** key to disable the selected output. The LED adjacent to the selected output should extinguish. If it does not, perform **KEYPAD** diagnostic test. If a relay is selected, it should de-energize, opening its contacts. If a triac is selected, it will turn off, de-energizing the device it is connected to. If relay does not de-energize or triac does not turn off, perform appropriate troubleshooting procedure below.
7. When all desired tests have been performed, press **DIAGNOSTICS** key to return to the **MAIN DIAGNOSTICS** Screen.
8. Install Motor Controller connection from TB6-I to TB6-53 removed in step 1.

Digital Inputs Troubleshooting:

If any of the Digital Inputs tests fail to perform as described above, perform the following steps in sequence. Refer to Figure 13 and applicable wiring diagram referenced at the beginning of Section 23. If a defective component is found during any of the following steps, replace the component as instructed and repeat the digi-

tal Inputs Procedure above to determine if the problem has been resolved.

1. Remove I/O Board ribbon cable. Using an Ohmmeter, perform a continuity check on I/O Board ribbon cable J1-21 to J19-21, J1-22 to J19-22 and applicable output pin of function that failed in Procedure above. If an open circuit is detected, replace ribbon cable. Otherwise, install ribbon cable and proceed to next step.
2. Measure the +5VDC supply voltage to the I/O Board on I/O Board between J1-21 and J1-22. If >4.5VDC, proceed to next step. If < 4.5VDC, disconnect ribbon cable at I/O Board J1 and repeat the measurement at J1. If <4.5VDC, replace the Microboard. Reinstall the ribbon cable.
3. With 115VAC ($\pm 10\%$) applied to the I/O Board digital input that failed in Procedure above, the applicable I/O Board output at J1 should be at a Logic low level (<1.0VDC). If it is >1.0VDC, replace the I/O Board. If the output is at a Logic Low level, the applicable LED should be illuminated. If the LED is not illuminated, replace the Microboard.
4. With 0VAC applied to the I/O Board digital input that failed in Procedure above, the applicable I/O Board output at J1 should be at a Logic High level (>4.0VDC). If it is <4.0VDC, replace the I/O Board. If the output is at a Logic High level, the applicable LED should be extinguished. If it is not extinguished, replace the Microboard.

Digital Outputs Troubleshooting:

If any of the Digital outputs tests fail to perform as described above, perform the following steps in sequence. Refer to Figure 16 and applicable wiring diagram referenced at the beginning of Section 23. If a defective component is found during any of the steps, replace the component as instructed and repeat the Procedure above to determine if the problem has been resolved.

1. Remove I/O Board ribbon cable. Using an Ohmmeter, perform a continuity test on the cable J1-25 to J19-25, J1-26 to J19-26 and applicable output pin of function that failed in Procedure above. If an open circuit is detected, replace ribbon cable. Otherwise, install ribbon cable and proceed to next step.
2. Measure the +12VDC supply voltage to the I/O Board on I/O Board between J1-26 (+12VDC) and J1-25 (Gnd). If >11.0VDC, proceed to next step. If <11.0VDC, disconnect ribbon cable at I/O Board J1 and repeat measurement at J1. If <11.0VDC, replace the Microboard. Reinstall the ribbon cable.

3. Using the Digital Outputs Procedure above, select the output that failed the digital Output test above.
4. Press **ENABLE OUTPUT** key. The LED adjacent to the selected output will illuminate. The appropriate Microboard output pin at J19 for the selected output should be at a Logic Low level (<1.0VDC). If it is >1.0VDC, replace the Microboard. With the output at a Logic Low, the following should occur:
 - a. If a Relay is selected as the output, the contacts of the relay should be closed. If they are not closed, replace the I/O Board.
 - b. If a Triac is selected as the output, the Triac should be turned on. If the Triac has not turned on, replace the I/O Board. See note 1 below for Triac testing.
5. Press **DISABLE OUTPUT** key. The LED adjacent to the selected output will extinguish.
 - a. If a Relay is selected as the output, the appropriate Microboard output pin at J19 for the selected output should be at a Logic High (>10.0VDC) level. With the output at a Logic High level, the relay contacts should be open. If they are not open, replace the I/O Board. If it is <10.0VDC, remove the ribbon cable from J1 of the I/O Board. On the

I/O Board, measure the resistance from J1-26 to the appropriate pin of J1 on the I/O Board for the selected relay. If the resistance is >100 Ohms, replace the I/O Board. If the resistance is <100 Ohms, replace the Microboard.

b. If a Triac is selected as the output, the appropriate Microboard output pin at J19 for the selected output should be at a Logic High (>10.0VDC) level. If it is <10.0VDC, replace the Microboard. With the output at a Logic High level, the Triac should be turned off. If the Triac has not turned off, replace the I/O Board. See note 1 below for Triac testing.

Notes:

1. The load (actuator) must be connected across the Triac to determine the on/off state of the Triac. The on/off state of the Triac can be determined by measuring across the device (for example, TB1-3 to TB1-59 or TB1-58 to TB1-59) with an AC Voltmeter. If the Triac is turned on, the voltage will be <10VAC. If the Triac is turned off, the voltage will be >100VAC (Slide Valve actuator) or >20VAC (PRV, Hot Gas or Refrigerant Level Control actuator).

ANALOG INPUTS TEST

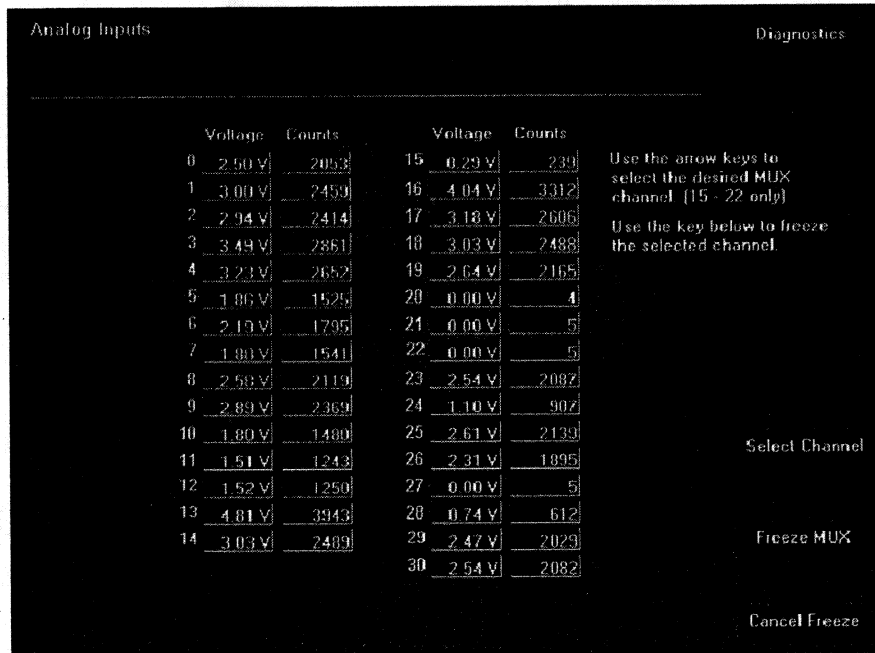

00385VIP

FIG. 68— ANALOG INPUTS TEST SCREEN

This diagnostic is used to analyze the Analog Inputs to the Microboard. The voltage level of each Analog input, as interpreted by the Microboard, is displayed. The "Counts" listed for each parameter is the Analog-to-Digital (A/D) converter value and is for manufacturing and engineering use only.

If the chiller is shutting down on an Analog Safety or is prevented from starting because of an Analog input, there is probably an Analog Input problem. This Screen can be used in the investigation of this problem.

Important! This test does not apply to the Leaving Chilled Liquid Temperature analog input or a 0-10VDC Remote Setpoint input at channels 27 and 28.

The following is a list of the Analog inputs displayed. Refer to the appropriate Section of this book for an explanation of each: Pressure Transducers - Section 16, Thermistors - Section 17, Purge System - Section 13, Refrigerant Level Control - Section 14, Solid State Starter (Mod "A" only) - Section 11 and Current Module (CM-2) - Section 10.

Channel

- 0 - +2.5VDC Analog supply voltage reference. Microboard TP6.
- 1 - Not Used

- 2 - Return Chilled Liquid Temperature
- 3 - Leaving Condenser Liquid Temperature
- 4 - Return Condenser Liquid Temperature
- 5 - Drop Leg Refrigerant Temperature
- 6 - Discharge Temperature
- 7 - Oil Temperature
- 8 - Evaporator Refrigerant Temperature
- 9 - Condenser Pressure
- 10 - Evaporator Pressure
- 11 - Sump Oil Pressure
- 12 - Pump Oil Pressure
- 13 - Not Used
- 14 - Purge Pressure
- 15 - Solid State Starter/CM-2 MUX output Channel 0
- 16 - Solid State Starter/CM-2 MUX output Channel 1
- 17 - Solid State Starter/CM-2 MUX output Channel 2
- 18 - Solid State Starter/CM-2 MUX output Channel 3
- 19 - Solid State Starter/CM-2 MUX output Channel 4
- 20 - Solid State Starter/CM-2 MUX output Channel 5
- 21 - Solid State Starter/CM-2 MUX output Channel 6
- 22 - Solid State Starter/CM-2 MUX output Channel 7
- 23 - Refrigerant Level Position
- 24 - Purge Canister Full Alarm (Optional)
- 25 - Not Used

- 26 - Not Used
- 27 - Remote Leaving Chilled Liquid Temperature Setpoint (0-20mA, 4-20mA)
- 28 - Remote Current Limit Setpoint (0-20mA, 4-20mA)
- 29 - Not Used
- 30 - Not Used

Procedure:

1. From the chart above, select the analog input that is malfunctioning. All inputs except channel 0, 15 through 22, 27 and 28 are sensors that connect directly to the Microboard via shielded cable. Channel 0 is a reference voltage for the Analog circuits on the Microboard. Channels 15 through 22 are multiplexed outputs from the Mod "A" Solid State Starter (Solid State Starter applications) or CM-2 Current Module (Electro-Mechanical Starter applications). Channels 27 and 28 are Remote Setpoint inputs used in Analog Remote mode.

2. Refer to Wiring Diagrams listed in front of this Section to identify the device that performs this function and the jack and pin connection to the Microboard.

3. • Channel 0:

Using a Voltmeter, measure the voltage between Microboard TP6 (+2.5VDC) and TP1 (Gnd).

Compare this measured value to the displayed value. If the value is not within $\pm 10\%$, replace the Microboard.

• All channels except 0, 1, 15-22:

Using a Voltmeter, measure the analog input to the Microboard. Make the measurement between the device output and Ground connection to the device. For example, measure the output of the Evaporator Transducer at Microboard J8-18 (signal) to J8-9 (Gnd).

• Channels 15-22:

Select the desired channel by pressing the **SELECT CHANNEL** key and using the **▲** and **▼** keys to place the arrow head next to the desired channel. Then, freeze the address of that channel to the Mod "A" Solid State Starter or CM-2 MUX. Then measure MUX output at Microboard J10-6 (signal) to J10-5 (Gnd). When completed, press **CANCEL FREEZE** key.

• Channels 27, 28:

IMPORTANT! This procedure only applies to 4-20mA inputs. It does not apply to 0-10VDC inputs. Using a Voltmeter, measure the Remote Current Limit setpoint input at J22-2 (signal) or Remote Leaving Chilled Liquid Temperature setpoint input at J22-4 (signal) to J22-5 (Gnd).

4. Compare the measured value in the previous step with the value displayed on the Analog Inputs Screen for that value.
5. If the measured value is not within $\pm 15\%$ of the displayed value, replace the Microboard. Otherwise, proceed to the troubleshooting procedure below to find the cause of the problem.
6. When all desired tests have been performed, press **DIAGNOSTICS** key to return the **MAIN DIAGNOSTICS** Screen.

Troubleshooting:

• All Channels except 0, 1, 15-22, 27, 28:

1. Disconnect both ends of the cable of the Analog input that is malfunctioning. Using an Ohmmeter, perform a continuity test on all conductors in the cable. An open circuit would indicate the cable is defective.
2. Using a Voltmeter, measure the +12VDC supply voltage input at the Microboard J1-3 (+12VDC) to J1-2 (Gnd). If voltage is $< 11.5\text{VDC}$, check wiring to Power Supply. If wiring is OK, the Power supply is most likely defective.
3. Using a Voltmeter, measure the supply voltage (+5VDC, +1 2VDC or +24VDC) to the sensor. If voltage is not within $\pm 10\%$ of specified voltage, disconnect J7, J8 and J9 from the Microboard. This disconnects all analog devices from the Microboard. If the voltage increases to the correct level, a Thermistor or Transducer is shorted. Locate the shorted device and replace. If, after disconnecting the connectors the supply voltage is still not within 10% of the specified value, the voltage supply source (Microboard or Power Supply) is most likely defective.
4. Verify sensor accuracy using appropriate test device. Replace sensor if necessary.

• Channels 15 - 22:

1. Disconnect both ends of ribbon cable connected to Microboard J10. Using an Ohmmeter, perform a continuity test on all conductors in the cable. An open circuit would indicate the cable is defective.

2. Using a Voltmeter, measure the +12VDC supply voltage input at the Microboard J1-3 (+12VDC) to J1-2 (Gnd). If voltage is <11.5VDC, check wiring to Power Supply. If wiring is OK, the Power Supply is most likely defective.
3. Using a Voltmeter, measure the +5VDC supply voltage to the Solid State Starter Logic Board or CM-2 Board. Make measurement at Microboard J10-4(+5VDC) to J10-5 (Gnd). If voltage is <4.5VDC, replace the Microboard.
4. Using a Voltmeter, verify the correct address is being sent from the Microboard to the Solid State Starter Logic Board or CM-2 Board. Freeze address as described above. If the address is correct, the Solid State Starter Logic Board or CM-2 Board or input devices to these boards is most likely the cause of

the problem. If address is not correct, the Microboard is most likely the cause of the problem.

5. Press **CANCEL FREEZE** key.

• **Channels 27, 28:**

1. Refer to Table 1 "Microboard Program Jumpers" and verify Program Jumpers JP23 and JP24 are configured correctly for the type of input (0-10VDC or 4-20mA).
2. Disconnect both ends of the cable of the remote input that is malfunctioning. Using an Ohmmeter, perform a continuity check on all conductors in the cable. An open circuit would indicate the cable is defective.
3. If steps are OK, problem most likely is in the remote device that supplies the remote signal.

SECTION 24

SYSTEM COMMISSIONING CHECKLIST

Use the following checklist during commissioning to assure all Setpoints have been programmed to the desired value and all calibrations have been performed. The programming of some of the Setpoints require a **SERVICE** access level. To assure access to all Setpoints, login at **SERVICE** access level before beginning. The Setpoints are grouped under the Display Screen in which they appear. The indented screens are subscreens of the numbered screens and are accessed from the numbered screens. An explanation of each setpoint or Calibration Procedure below is contained in the reference document listed in parenthesis adjacent to each item. If any of the Setpoints have to be changed, use the standard programming procedures in Operation Manual Form 160.55-O1. Thresholds, values and calibrations of items marked with an asterisk "*" have been determined and entered/set at the YORK Factory at the time of manufacture.

1. PROGRAM JUMPERS/SWITCHES: (160.55-M1)

___ Verify Microboard Program Jumpers and Program Switches are configured appropriately.

2. EVAPORATOR Screen: (160.55-O1)

Enter the following Setpoints:

___ Leaving Chilled Liquid Temp (except ISN Remote mode)

___ Remote Leaving Chilled Liquid Temp Setpoint Range (except ISN Remote mode)

___ Low Chilled Liquid Temp cycling shutdown temperature

___ Low Chilled Liquid Temp cycling shutdown Restart temperature

___ Leaving Chilled Liquid Temp control Sensitivity (160.55-M1)

___ Brine Low Evaporator Pressure Cutout threshold* (160.55-M1)

___ Smart Freeze Protection On/Off (160.55-M1)

___ Refrigerant Temp Sensor Enable/Disable (160.55-M1)

3. CONDENSER Screen: (160.55-M1)

___ Enter the High Pressure Limit/Warning threshold Setpoint

___ Drop Leg refrigerant Temp Sensor Enable/Disable

PURGE Screen: (160.55-M1)

___ High Efficiency Purge Enable/Disable

___ Enter the Maximum Purges/Hour Setpoint

REFRIGERANT LEVEL CONTROL/TUNING Screen: (160.55-M1) (Optional - Flash Memory Card Version C.MLM.02.01.100 or C.MLM.02.01.200 and later versions)

Verify the following Setpoints:

___ Level Setpoint*

___ Control Period*

___ Proportional Limit Open*

___ Proportional Limit Close*

___ Rate Limit Open*

___ Rate Limit Close*

___ Manual or Auto control (as desired)

___ Verify Refrigerant Level Sensor calibration

4. COMPRESSOR Screen: (160.55-M1)

___ Select Pre-rotation Vanes Manual or Auto control.

HOT GAS BYPASS Screen: (160.55-M1)

If chiller is equipped with optional Hot Gas Bypass, enable operation on the **OPERATIONS** screen and enter the following setpoints:

___ Maximum Open (Flash Memory Card version C.MLM.02.02.xxx and later)

___ Surge Sensitivity (moved to Surge Protection Screen in Flash Memory Card version C.MLM.02.02.xxx and later)

___ Hold Period

___ Close Percentage

___ Minimum Load

___ Manual or Auto Control, as desired

SURGE PROTECTION Screen: (160.55-M1) (Flash Memory Card version C.MLM.02.02.xxx and later)

___ Enable/Disable Excess Surge Shutdown feature

___ Enable/Disable Extended Run feature

___ Count Window

___ Count Limit

___ Surge Sensitivity

PRE-ROTATION VANES CALIBRATE Screen:

___ Perform Pre-rotation Vanes calibration (compressor motor VSD applications only)

VSD TUNING Screen:

___ Select Auto or Manual compressor motor frequency control (compressor motor VSD applications only)

5. MOTOR Screen:

___ Enter the desired Current Limit Setpoint (160.55-01)

___ Enter the desired Pulldown Demand Limit and Time Setpoint (160.55-01)

Solid State Starter Applications: (160.55-M1)

Mod "B" Solid State Starter:

Verify the following Setpoints have been programmed:

___ Full Load Amps*

___ Start Current*

___ Supply Voltage Range*

___ Enable Open SCR Detection

___ Enable Shorted SCR Detection (Flash Memory Card version C.MLM.02.01 and later)

___ KWH Reset

Mod "A" Solid State Starter:

Verify the following Setpoints have been programmed:

___ Full Load Amps*

___ Supply Voltage Range*

___ Current Unbalance Check – Enable/Disable*

Logic Board:

___ Verify location of 300V/600V Jumper*

___ Verify Start Current calibration*

___ Verify 105% FLA calibration*

Electro-Mechanical Starter applications: (160.55-M1)

Current Module:

___ Verify Switch S1 (Ydelta/57% or all others) setting*

___ Verify Pot R16 (LRA/FLA ratio) setting*

___ Verify slide bar resistor "RES" setting*

___ Verify 105% FLA calibration*

___ Verify 100% FLA display*

Variable Speed Drive applications: (160.55-M1 and 160-00-M1)

___ KWH Reset

VSD DETAILS Screen:

___ Set chiller Full Load amps (FLA) value by adjusting Potentiometer on VSD Logic Board

ADAPTIVE CAPACITY CONTROL (ACC)

DETAILS Screen:

___ Surge Map Auto Print Enable/Disable

The following Setpoints should not be changed unless instructed by YORK Factory.

___ Surge Margin adjust*

___ Stability Limit*

6. SETPOINTS Screen: (160.55-01)

The setpoints listed on the SETPOINTS Screen have already been programmed above on Previous Screens. The values shown reflect the previously programmed values. However, the setpoints listed here can be changed on this screen if desired. This screen is used primarily as a central location from which most setpoints can be programmed. If it is not desired to change any of the listed setpoints, proceed to the SETUP Screen below.

SETUP Screen:

___ Enable Clock

___ Enter CLOCK Time and Date

___ Select 12 or 24 hour display mode

___ The state of Program Jumpers/Switches that affect Chiller operation are shown on the setup Screen. These were configured in step 1 above. Refer to Table 1 and 2 of Service Manual 160.55-M1 if it is desired to change them.

SCHEDULE Screen:

___ Enable or Disable Daily start/stop schedule as required.

___ Enter chiller START/STOP schedule if required.

USER Screen:

___ Select desired Display language

___ Select desired Display units; ENGLISH or METRIC

___ If desired, establish custom USER ID's and PASSWORDS (160.55-M1)

COMMS Screen:

If Modem and or Printer is connected to the Microboard Serial data ports, enter the following parameters as required for each device connected:

___ Baud rate

___ Number of data bits

___ Number of stop bits

___ Parity

Enter appropriate number for Modem, Printer or ISN Remote application:

___ Chiller ID (identification)

PRINTER Screen:

If Printer is connected to Microboard serial ports, enter the following:

- Automatic print logging Enable/disable
- Automatic printer logging start time
- Automatic print logging interval
- Printer type
- Report type; STATUS, SETPOINTS, SCHEDULE or SALES ORDER

SALES ORDER Screen:

- Enter system commissioning date

OPERATIONS Screen:

- Select desired Control Source (operating mode); LOCAL, ISN Remote, DIGITAL Remote or ANALOG Remote
- Refrigerant Level Control operation Enable/Disable (Future)
- Hot Gas Bypass Control (optional) Enable/Disable
- Edit Regional phone number if necessary (Flash Memory Card version C.MLM.02.02.xxx and later)
- Enter Local phone number (Flash Memory Card version C.MLM.02.02.xxx and later)

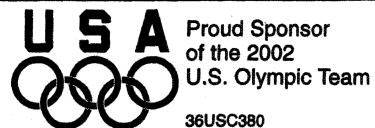

P.O. Box 1592, York, Pennsylvania USA 17405-1592
Copyright © by York International Corporation 2001
FORM 160.55-M1 (101)
SUPERSEDES: 160.55-M1 (400), 160.55-M1 (LS1) (700)

Tele. 800-861-1001
www.york.com

Subject to change without notice. Printed in USA
ALL RIGHTS RESERVED
SHU 3M 301 12.48
CODE: SJ4