



BY JOHNSON CONTROLS

MAXE™ CENTRIFUGAL LIQUID CHILLERS

SERVICE INSTRUCTIONS

Supersedes: 160.54-M1 (309)

Form 160.54-M1 (809)

OPTIVIEW™ CONTROL CENTER

- 371-02264-101 (Electro-Mechanical Starter - NEMA 1)
- 371-02486-101 (Electro-Mechanical Starter - CE)
- 371-02448-101 (Electro-Mechanical Starter - NEMA 4/12)
- 371-02264-102 (Solid State Starter - NEMA 1)
- 371-02486-102 (Solid State Starter - CE)
- 371-02448-102 (Solid State Starter - NEMA 4/12)
- 371-02264-103 (Variable Speed Drive - NEMA 1)
- 371-02486-103 (Variable Speed Drive - CE)
- 371-02448-103 (Variable Speed Drive - NEMA 4/12)
- 371-02778-101 (Electro-Mechanical Starter - NEMA 1)
(P Compressors until 8/02)
- 371-02780-101 (Electro-Mechanical Starter - CE)
(P Compressors until 8/02)
- 371-02779-101 (Electro-Mechanical Starter - NEMA 4/12)
(P Compressors until 8/02)
- 371-02778-102 (MOD "B" Solid State Starter - NEMA 1)
(P Compressors until 8/02)
- 371-02780-102 (MOD "B" Solid State Starter - CE)
(P Compressors until 8/02)
- 371-02779-102 (MOD "B" Solid State Starter - NEMA 4/12)
(P Compressors until 8/02)
- 371-02778-103 (Variable Speed Drive - NEMA 1-4)
(P Compressors until 8/02)
- 371-02780-103 (Variable Speed Drive - CE)
(P Compressors until 8/02)
- 371-02779-103 (Variable Speed Drive - NEMA 4/12)
(P Compressors until 8/02)
- 371-04118-101 (Electro-Mechanical Starter – NEMA 1)
(Style F Chillers)
- 371-04118-102 (Style B Solid State Starter – NEMA 1)
(Style F Chillers)
- 371-04118-103 (Variable Speed Drive – NEMA 1)
(Style F Chillers)
- 371-04118-110 (Mod B Solid State Starter or Variable
Speed Drive w/Modbus Communications
- no VGD - NEMA 1)
 - 111 (Mod B Solid State Starter or Variable
Speed Drive w/Modbus communications &
VGD, no J7 compressor – NEMA 1)
 - 112 (Mod B Solid State Starter or Variable
Speed Drive w/Modbus communications &
VGD, J7 compressor – NEMA 1)
- 371-04119-101 (Electro-Mechanical Starter – NEMA 4/12)
(Style F Chillers)
- 371-04119-102 (Mod "B" Solid State Starter - NEMA 4/12)
(Style F Chillers)
- 371-04119-103 (Variable Speed Drive – NEMA 4/12)
(Style F Chillers)
- 371-04119-110 (Mod B Solid State Starter or Variable
Speed Drive w/Modbus Communications
- no VGD - NEMA 4-12)
 - 111 (Mod B Solid State Starter or Variable
Speed Drive w/Modbus communications &
VGD, no J7 compressor – NEMA 4-12)
 - 112 (Mod B Solid State Starter or Variable
Speed Drive w/Modbus communications &
VGD, J7 compressor – NEMA 4-12)
- 371-04120-101 (Electro-mechanical Starter – CE) (Style F
Chillers)
- 371-04120-102 (Mod "B" Solid State Starter – CE)
(Style F Chillers)
- 371-04120-103 (Variable Speed Drive – CE)
(Style F Chillers)
- 371-04120-110 (Mod B Solid State Starter or Variable
Speed Drive w/Modbus Communications
- no VGD - CE)
 - 111 (Mod B Solid State Starter or Variable
Speed Drive w/Modbus communications &
VGD, no J7 compressor – CE)
 - 112 (Mod B Solid State Starter or Variable
Speed Drive w/Modbus communications &
VGD, J7 compressor – NEMA 1)

MODEL YK (THROUGH STYLE G)

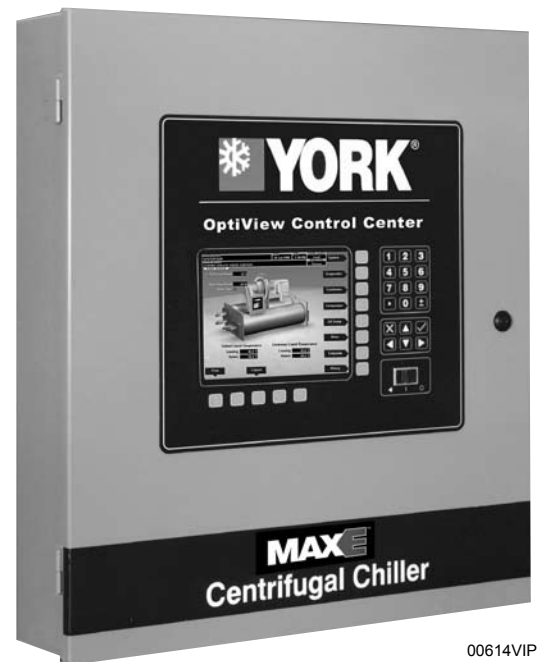

Metric Conversions

00614VIP

IMPORTANT!

READ BEFORE PROCEEDING!

GENERAL SAFETY GUIDELINES

This equipment is a relatively complicated apparatus. During installation, operation, maintenance or service, individuals may be exposed to certain components or conditions including, but not limited to: refrigerants, oils, materials under pressure, rotating components, and both high and low voltage. Each of these items has the potential, if misused or handled improperly, to cause bodily injury or death. It is the obligation and responsibility of operating/service personnel to identify and recognize these inherent hazards, protect themselves, and proceed safely in completing their tasks. Failure to comply with any of these requirements could result in serious damage to the equipment and the property in

which it is situated, as well as severe personal injury or death to themselves and people at the site.

This document is intended for use by owner-authorized operating/service personnel. It is expected that this individual possesses independent training that will enable them to perform their assigned tasks properly and safely. It is essential that, prior to performing any task on this equipment, this individual shall have read and understood this document and any referenced materials. This individual shall also be familiar with and comply with all applicable governmental standards and regulations pertaining to the task in question.

SAFETY SYMBOLS

The following symbols are used in this document to alert the reader to areas of potential hazard:



DANGER indicates an imminently hazardous situation which, if not avoided, will result in death or serious injury.



CAUTION identifies a hazard which could lead to damage to the machine, damage to other equipment and/or environmental pollution. Usually an instruction will be given, together with a brief explanation.



WARNING indicates a potentially hazardous situation which, if not avoided, could result in death or serious injury.

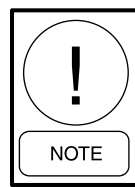

NOTE is used to highlight additional information which may be helpful to you.



External wiring, unless specified as an optional connection in the manufacturer's product line, is NOT to be connected inside the micro panel cabinet. Devices such as relays, switches, transducers and controls may NOT be installed inside the micro panel. NO external wiring is allowed to be run through the micro panel. All wiring must be in accordance with YORK's published specifications and must be performed ONLY by qualified Johnson Controls personnel. Johnson Controls will not be responsible for damages/problems resulting from improper connections to the controls or application of improper control signals. Failure to follow this will void the manufacturer's warranty and cause serious damage to property or injury to persons.

CHANGEABILITY OF THIS DOCUMENT

In complying with Johnson Controls policy for continuous product improvement, the information contained in this document is subject to change without notice. While Johnson Controls makes no commitment to update or provide current information automatically to the manual owner, that information, if applicable, can be obtained by contacting the nearest Johnson Controls Service office.

It is the responsibility of operating/service personnel as to the applicability of these documents to the equipment in question. If there is any question in the mind of operating/service personnel as to the applicability of these documents, then, prior to working on the equipment, they should verify with the owner whether the equipment has been modified and if current literature is available.

REFERENCE INSTRUCTIONS

DESCRIPTION	FORM NO.
SOLID STATE STARTER (MOD "A") – OPERATION & MAINTENANCE	160.46-OM3.1
SOLID STATE STARTER (MOD "B") – OPERATION & MAINTENANCE	160.00-O2
MEDIUM VOLTAGE SOLD STATE STARTER – SERVICE	160.00-M5
VARIABLE SPEED DRIVE – OPERATION	160.00-O1
VARIABLE SPEED DRIVE – SERVICE INSTRUCTIONS	160.00-M1
MEDIUM VOLTAGE VARIABLE SPEED DRIVE – SERVICE	160.00-M6
VARIABLE SPEED OIL PUMP DRIVE	160.52-M2
INSTALLATION	160.54-N1
OPERATION	160.54-O1
WIRING DIAGRAM – UNIT (STYLE E) WITH ELECTRO-MECHANICAL STARTER	160.54-PW1
WIRING DIAGRAM – UNIT (STYLE E) WITH MOD "A" SOLID STATE STARTER	160.54-PW2
WIRING DIAGRAM – UNIT (STYLE E) WITH MOD "B" SOLID STATE STARTER	160.54-PW2.1
WIRING DIAGRAM – UNIT (STYLE E) WITH VARIABLE SPEED DRIVE	160.54-PW3
WIRING DIAGRAM – UNIT (STYLE E) (P COMPRESSORS) WITH ELECTRO-MECHANICAL STARTER	160.54-PW8
WIRING DIAGRAM – UNIT (STYLE E) (P COMPRESSORS) WITH MOD "B" SOLID STATE STARTER	160.54-PW9
WIRING DIAGRAM – UNIT (STYLE E) (P COMPRESSORS) VARIABLE SPEED DRIVE	160.54-PW10
RENEWAL PARTS – UNIT	160.49-RP4
RENEWAL PARTS – OPTIVIEW CONTROL CENTER	160.54-RP1
WIRING DIAGRAM – UNIT (STYLE F) (ALL COMPRESSORS) WITH ELECTRO-MECHANICAL STARTER	160.73-PW1
WIRING DIAGRAM – UNIT (STYLE F) (ALL COMPRESSORS) WITH MOD "A" SOLID STATE STARTER	160.73-PW2
WIRING DIAGRAM – UNIT (STYLE F) (ALL COMPRESSORS) WITH VARIABLE SPEED DRIVE	160.73-PW3
WIRING DIAGRAM – UNIT (STYLE F) (ALL COMPRESSORS WITH MEDIUM VOLTAGE VSD OR MEDIUM VOLTAGE SSS)	160.73-PW5
WIRING DIAGRAM – UNIT (STYLE G) FIELD CONTROL MODIFICATIONS	160.75-PW4
WIRING DIAGRAM – UNIT (STYLE G) W/ ELECTRO-MECHANICAL STARTER	160.75-PW5
WIRING DIAGRAM – UNIT (STYLE G) WITH SSS, LV VSD WITH MODBUS & MV VSD	160.75-PW6

NOMENCLATURE

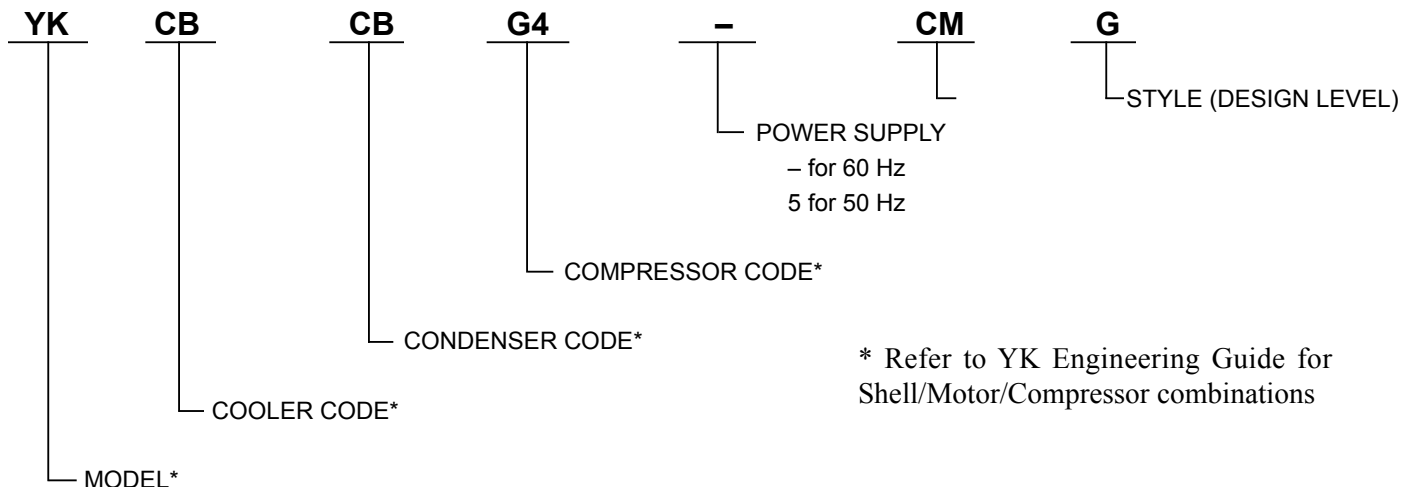

TABLE OF CONTENTS

SECTION 1 - INTRODUCTION.....	8	SECTION 5 - LIQUID CRYSTAL DISPLAY	71
SECTION 2 - SYSTEM ARCHITECTURE	10	BACKLIGHT LAMP REPLACEMENT.....	73
SECTION 3 - MICROBOARD 031-01730-000.....	23	SECTION 6 - DISPLAY INTERFACE BOARD.....	80
BOOT-UP STEP AND DESCRIPTION	25	SECTION 7 - DISPLAY BACKLIGHT INVERTER	
LED INDICATORS.....	25	BOARD	84
PROGRAM JUMPERS/PROGRAM SWITCHES	25	SECTION 8 - KEYPAD.....	87
KEYPAD INTERFACE	25	SECTION 9 - POWER SUPPLY.....	90
CM-2 BOARD OR STYLE A SOLID STATE STARTER		SECTION 10 - CURRENT MODULE (CM-2).....	92
INTERFACE.....	26	SECTION 11 - SOLID STATE STARTERS	96
STYLE B SOLID STATE STARTER OR VARIABLE		SOLID STATE STARTERS	96
SPEED DRIVE INTERFACE	26	MEDIUM VOLTAGE SOLID STATE STARTER	96
PRINTER INTERFACE.....	26	STYLE B LC SSS	96
MICROGATEWAY INTERFACE	26	SECTION 12 - ADAPTIVE CAPACITY	
DIGITAL INPUTS	27	CONTROL BOARD.....	104
DIGITAL OUTPUTS.....	27	SPEED INCREASE	107
ANALOG INPUTS.....	27	PRV CLOSE	107
SERIAL DATA PORTS	28	SECTION 13 - PROXIMITY PROBE.....	116
DISPLAY INTERFACE.....	28	SECTION 13A - HIGH SPEED THRUST BEARING	
REMOTE SETPOINTS.....	29	LIMIT SWITCH.....	122
POWER SUPPLY	29	SECTION 14 - REFRIGERANT LEVEL	
SERVICE REPLACEMENT	29	CONTROL.....	124
SECTION 3A - MICROBOARD 031-02430-000		AUTOMATIC OPERATION.....	124
and 031-02430-001.....	40	MANUAL OPERATION	126
TEST POINTS	40	ACTUATORS	126
BOOT UP PROGRAM	40	SECTION 15 - OIL PUMP VARIABLE SPEED	
DIAGNOSTIC DISPLAY CODES.....	41	DRIVE.....	128
CHILLER OPERATING PROGRAM.....	41	AUTOMATIC OPERATION	128
PROGRAM CARD	41	MANUAL OPERATION	129
PROGRAM DOWNLOAD CONNECTOR U33	42	OIL HEATER OPERATION.....	130
PARALLEL PORT CONNECTOR.....	42	SECTION 16 - MICROGATEWAY.....	132
WATCHDOG CIRCUIT	43	SECTION 17 - PRESSURE TRANSDUCERS	133
PROGRAM JUMPERS/PROGRAM SWITCHES	43	PRESSURE TRANSDUCER APPLICATIONS CHART	
KEYPAD INTERFACE	43	135
CM-2 BOARD OR STYLE A SOLID STATE STARTER		SECTION 18 - TEMPERATURE THERMISTORS..	136
INTERFACE.....	44	SECTION 19 - REMOTE SETPOINTS.....	154
MULTIPLEXER CHANNELS	44	CURRENT LIMIT	154
VARIABLE SPEED DRIVE INTERFACE	45	LEAVING CHILLED LIQUID TEMPERATURE	154
STYLE B SOLID STATE STARTER OR VARIABLE		SECTION 20 - HOT GAS BYPASS	159
SPEED DRIVE INTERFACE	44	SETPOINTS	160
PRINTER INTERFACE.....	45	OPERATION.....	160
MICROGATEWAY INTERFACE	45	HOT GAS OPERATION WITH VARIABLE GEOMETRY	
DIGITAL INPUTS	45	DIFFUSER (VGD).....	161
DIGITAL OUTPUTS	46	MANUAL CONTROL	161
ANALOG INPUTS.....	46	ANALOG I/O BOARD	161
SERIAL DATA PORTS	46		
DISPLAY INTERFACE.....	47		
REMOTE SETPOINTS.....	48		
CONFIGURATION/SETUP	48		
MICROBOARD SERVICE REPLACEMENT	50		
PROGRAM CARD SERVICE REPLACEMENT	51		
DOWNLOADING A PROGRAM FROM A			
PROGRAM CARD	52		
SECTION 4 - I/O BOARD	61		
RELAY TIMING.....	62		

TABLE OF CONTENTS (CONT'D)

SECTION 21 - SMART FREEZE PROTECTION... 163	MEDIUM VOLTAGE SOLID STATE STARTER202
SECTION 22 - SURGE PROTECTION 165	COMPRESSOR MOTOR VARIABLE SPEED
SURGE DETECTION165	DRIVE APPLICATIONS203
EXCESS SURGE DETECTION165	PROXIMITY PROBE205
SURGE PROTECTION166	HIGH SPEED THRUST BEARING LIMIT SWITCH.....207
HOT GAS BYPASS/COMPRESSOR MOTOR VARIABLE	REFRIGERANT LEVEL CONTROL207
SPEED DRIVE (VSD) APPLICATIONS167	OIL PUMP VARIABLE SPEED DRIVE208
SECTION 22A - VARIABLE GEOMETRY	STANDBY LUBRICATION209
DIFFUSER..... 168	HIGH CONDENSER PRESSURE WARNING
STALL DETECTION168	THRESHOLD.....210
SURGE DETECTION168	BRINE LOW EVAPORATOR PRESSURE CUTOUT210
AUTOMATIC OPERATION.....168	LEAVING CHILLED LIQUID TEMPERATURE
STALL SENSOR VALIDATION170	CONTROL SENSITIVITY210
EXTREME STALL MONITOR.....170	DROP LEG REFRIGERANT TEMPERATURE.....211
MANUAL OPERATION170	SMART FREEZE PROTECTION211
SETPOINTS170	EVAPORATOR REFRIGERANT TEMPERATURE.....211
PRE-ROTATION VANES POSITION171	HOT GAS BYPASS CONTROL.....211
I/O BOARD171	CHILLER STARTS AND OPERATING HOURS
STALL TRANSDUCER172	RESET.....212
STALL DETECTOR BOARD.....172	SERVICE PHONE NUMBERS212
SECTION 23 - LTC I/O BOARD..... 178	SURGE PROTECTION213
DIGITAL INPUTS178	SALES ORDER DATA213
DIGITAL OUTPUTS180	CUSTOM USER ID AND PASSWORDS214
ANALOG INPUTS.....181	RECORD SETPOINT CHANGES215
ANALOG OUTPUTS.....182	CHILLER STYLE/COMPRESSOR215
AUTO DETECTION183	FLOW SWITCH218
DIAGNOSTIC SCREEN183	MICROBOARD 031-02430-000 SETUP/
SECTION 24 - HEAT RECOVERY 184	CONFIGURATION219
INPUTS/OUTPUTS184	VARIABLE GEOMETRY DIFFUSER219
CONTROL184	HIGH CONDENSOR PRESSURE FAULT WHILE
REMOTE HOT WATER SETPOINT188	SHUTDOWN-RESET PROCEDURE221
CONDENSER FLOW SWITCH OPEN FAULT188	MOTOR LUBRICATION NOTIFICATION221
SECTION 25 - HEAD PRESSURE CONTROL..... 189	SECTION 28 - DIAGNOSTICS &
INPUTS/OUTPUTS189	TROUBLESHOOTING 224
CONTROL190	MAIN DIAGNOSTICS SCREEN226
OPERATION WHEN EQUIPPED WITH BOTH	KEYPAD TEST229
HEAT RECOVERY & HEAD PRESSURE CONTROL191	DISPLAY TEST230
SECTION 26 - QUICK START 192	BIT PATTERNS TEST231
SETPOINTS192	SERIAL INPUTS / OUTPUTS TESTS232
SECTION 27 - SYSTEM CALIBRATION, SERVICE	DIGITAL INPUTS / OUTPUTS TESTS234
SETPOINTS AND RESET	ANALOG INPUTS TEST237
PROCEDURES 198	SECTION 29 - SYSTEM COMMISSIONING
ELECTRO-MECHANICAL STARTER	CHECKLIST 240
APPLICATIONS.....198	SECTION 30 - SOFTWARE ENHANCEMENTS 246
CALIBRATION VERIFICATION:198	SI0006 - SOFTWARE ENHANCEMENTS
SOLID STATE STARTER APPLICATIONS.....199	EFFECTIVE MAY 2001246
MOD "B" LIQUID COOLED SOLID STATE	SI0019 - SOFTWARE ENHANCEMENTS
STARTER199	EFFECTIVE MARCH 2002248
MOD "A" LIQUID COOLED SOLID STATE	SI0034 (203) - SOFTWARE ENHANCEMENTS
STARTER201	EFFECTIVE AUGUST 2002.....251
	SI0058 - SOFTWARE ENHANCEMENTS
	EFFECTIVE FEBRUARY 2003.....254
	SI0062 - SOFTWARE ENHANCEMENTS
	EFFECTIVE MARCH 2003256

TABLE OF CONTENTS (CONT'D)

SI0080 - SOFTWARE ENHANCEMENTS EFFECTIVE JANUARY 2004.....	258	SI0164 - SOFTWARE ENHANCEMENTS EFFECTIVE APRIL 2007	266
SI0089 - SOFTWARE ENHANCEMENTS EFFECTIVE MAY 2004	260	SI0186 - SOFTWARE ENHANCEMENTS EFFECTIVE MARCH 2008	269
160.54-M1 (LS05) SOFTWARE ENHANCEMENTS EFFECTIVE MARCH 2005	262	SI0201 - SOFTWARE ENHANCEMENTS EFFECTIVE OCTOBER 2008.....	272
SI0148 - SOFTWARE ENHANCEMENTS EFFECTIVE JUNE 2006	264	SI0210 - SOFTWARE ENHANCEMENTS EFFECTIVE JUNE 2009.....	278
SI0158 - SOFTWARE ENHANCEMENTS EFFECTIVE OCTOBER 2006.....	265	SI0212 - SOFTWARE ENHANCEMENTS EFFECTIVE JUNE 2009.....	280

LIST OF FIGURES

FIG. 1 – OPTIVIEW CONTROL CENTER - ELECTRO-MECHANICAL STARTER APPLICATIONS.....	14	FIG. 13 – I/O BOARD	66
FIG. 2 – OPTIVIEW CONTROL CENTER - MOD “A” SOLID STATE STARTER APPLICATIONS	15	FIG. 14 – I/O BOARD DIGITAL INPUTS	67
FIG. 3 – OPTIVIEW CONTROL CENTER - MOD “B” SOLID STATE STARTER APPLICATIONS	16	FIG. 15 – I/O BOARD TYPICAL OPTO-COUPLER CIRCUIT	68
FIG. 3A – OPTIVIEW CONTROL CENTER - MEDIUM VOLTAGE SOLID STATE STARTER APPLICATIONS	17	FIG. 16 – I/O BOARD TYPICAL FIELD CONNECTIONS.....	68
FIG. 4 – OPTIVIEW CONTROL CENTER - COMPRESSOR MOTOR VARIABLE SPEED DRIVE.....	18	FIG. 17 – I/O BOARD DIGITAL OUTPUTS	69
FIG. 4A – OPTIVIEW CONTROL CENTER - COMPRESSOR MOTOR VARIABLE SPEED DRIVE (MODBUS SERIAL COMMUNICATIONS PROTOCOL).....	19	FIG. 18 – DISPLAY, MOUNTING	75
FIG. 4B – OPTIVIEW CONTROL CENTER - COMPRESSOR MOTOR MEDIUM VOLTAGE VARIABLE SPEED DRIVE	20	FIG. 19 – LIQUID CRYSTAL DISPLAY ASSEMBLY – SHARP LQ10D367/368 (031-01774-000) DISPLAY.....	76
FIG. 5 – OPERATION SEQUENCE TIMING DIAGRAM (ELECTRO-MECHANICAL & SOLID STATE STARTER APPLICATIONS).....	21	FIG. 20 – LIQUID CRYSTAL DISPLAY ASSEMBLY – SHARP LQ104V1DG61 DISPLAY.....	76
FIG. 6 – OPERATION SEQUENCE TIMING DIAGRAM (COMPRESSOR MOTOR VARIABLE SPEED DRIVE APPLICATIONS).....	22	FIG. 21 – LIQUID CRYSTAL DISPLAY ASSEMBLY – NOT AVAILABLE	77
FIG. 7 – MICROBOARD 031-01730-000	30	FIG. 22 – LIQUID CRYSTAL DISPLAY ASSEMBLY - LG SEMICON LP104V2-W (031-02046-000).....	78
FIG. 8 – FLASH MEMORY CARD.....	31	FIG. 23 – LIQUID CRYSTAL DISPLAY TYPICAL CONTROL SIGNAL TIMING.....	78
FIG. 9 – MICROBOARD (031-01730-000) POWER SUPPLY TEST POINTS	32	FIG. 24 – DISPLAY (SHARP LQ10D367/368) LAMP REPLACEMENT (031-02046-000).....	79
FIG. 10 – MICROBOARD LAMP DIMMER CIRCUIT	37	FIG. 25 – DISPLAY (SHARP LQ104V1DG61/LP104V2-W) LAMP REPLACEMENT	79
FIG. 11 – MICROBOARD SERIAL DATA COMMUNICATIONS PORTS	38	FIG. 26 – NOT AVAILABLE	80
FIG. 12 – CONFIGURABLE ANALOG & REMOTE SETPOINT INPUTS	39	FIG. 27 – NOT AVAILABLE	80
FIG. 7A – MICROBOARD 031-02430-000.....	56	FIG. 28 – DISPLAY INTERFACE BOARD.....	82
FIG. 8A – PROGRAM CARD 031-02474-001.....	57	FIG. 29 – DISPLAY INTERFACE BOARD.....	83
FIG. 9A – MICROBOARD (031-02430-000) DC POWER SUPPLY TEST POINTS	57	FIG. 30 – DISPLAY BACKLIGHT INVERTER BOARD (SHARP LQ10D367/368 (031-01774-000) & LG SEMICON LP104V2-W (031-02046-000))	86
FIG. 10A – MICROBOARD LAMP DIMMER CIRCUIT	58	FIG. 31 – DISPLAY BACKLIGHT INVERTER BOARD (SHARP LQ104V1DG61).....	87
FIG. 11A – MICROBOARD SERIAL DATA COMMUNICATIONS PORTS.....	59	FIG. 32 – KEYPAD	89
FIG. 12A – CONFIGURABLE ANALOG & REMOTE SETPOINT INPUTS	60	FIG. 33 – KEYPAD	90
FIG. 12B - LOW VOLTAGE DIGITAL INPUTS	61	FIG. 34 – POWER SUPPLY	91
		FIG. 35 – POWER SUPPLY – DC POWER DISTRIBUTION	92
		FIG. 36 – CM-2 CURRENT MODULE (ELECTRO-MECHANICAL STARTER APPLICATION).....	95
		FIG. 37 – CM-2 CURRENT MODULE (ELECTRO-MECHANICAL STARTER APPLICATIONS).....	95
		FIG. 38 – CM-2 CURRENT MODULE – INTERFACE, CURRENT TRANSFORMERS & VARIABLE RESISTORS.....	96

LIST OF FIGURES (CONT'D)

FIG. 39 – MOD “B” LIQUID COOLED SOLID STATE STARTER (LCSSS) - INTERFACE	100	FIG. 59 – RETURN CHILLED LIQUID TEMPERATURE	144
FIG. 40 – SOLID STATE STARTER LOGIC BOARD	101	FIG. 60 – RETURN AND LEAVING CONDENSING WATER.....	146
FIG. 41 – MOD “A” LIQUID COOLED SOLID STATE STARTER (LCSSS) - INTERFACE	104	FIG. 61 – OIL AND DISCHARGE TEMPERATURE	149
FIG. 42 – COMPRESSOR MOTOR VARIABLE SPEED DRIVE (VSD) ADAPTIVE CAPACITY CONTROL (ACC) BOARD	113	FIG. 62 – DROP LEG REFRIGERANT SENSOR	154
FIG. 43 – ADAPTIVE CAPACITY CONTROL (ACC) BOARD - INTERFACE	114	FIG. 63 – EVAPORATOR REFRIGERANT SENSOR	154
FIG. 43A – SERIAL COMMUNICATIONS INTERFACE - YORK PROTOCOL	114	FIG. 64 – INTERFACE, HOT GAS BYPASS	165
FIG. 43B – SERIAL COMMUNICATIONS INTERFACE - MODBUS PROTOCOL.....	115	FIG. 64A – VARIABLE GEOMETRY DIFUSER BLOCK DIAGRAM.....	176
FIG. 44 – ADAPTIVE CAPACITY CONTROL (ACC) BOARD.....	116	FIG. 64B – VARIABLE GEOMETRY DIFFUSER STATE DIAGRAM.....	177
FIG. 45 – PROXIMITY PROBE INTERFACE-PROBE PART NUMBER 025-30961-000	120	FIG. 65 – LTC I/O BOARD BLOCK DIAGRAM	179
FIG. 46 – PROXIMITY PROBE INTERFACE-PROBE PART NUMBER 025-35900-000 AND 025-35900-001	120	FIG. 65A – 120VAC DIGITAL INPUT.....	179
FIG. 47 – PROXIMITY PROBE INTERFACE – PROBE PART NUMBER 025-40496-000.....	121	FIG. 65B – +5VDC DIGITAL INPUT	180
FIG. 48 – PROXIMITY PROBE	122	FIG. 65C – RELAY OUTPUTS	181
FIG. 49 – HIGH SPEED THRUST BEARING LIMIT SWITCH - INTERFACE	123	FIG. 65D – TRIAC OUTPUTS	180
FIG. 50 – HIGH SPEED THRUST BEARING LIMIT SWITCH	124	FIG. 65E – OPEN COLLECTOR	181
FIG. 51 – REFRIGERANT LIQUID LEVEL SENSOR.....	127	FIG. 65F – ANALOG INPUTS	181
FIG. 52 – REFRIGERANT LIQUID LEVEL CONTROL - INTERFACE	128	FIG. 65G – ANALOG OUTPUTS.....	182
FIG. 53 – OIL PUMP VARIABLE SPEED DRIVE (VSD).....	131	FIG. 66 – LTC I/O BOARD	183
FIG. 54 – OIL PUMP VSD / OIL HEATER CONTROL – INTERFACE	132	FIG. 67 – HEAT RECOVERY BLOCK DIAGRAM	185
FIG. 55 – OIL PUMP VSD SPEED CONTROL SIGNAL	132	FIG. 68 – PID CONTROLLER DIAGRAM	186
FIG. 56 – MICROGATEWAY INTERFACE BLOCK DIAGRAM.....	133	FIG. 69 – HEAT RECOVERY BLOCK DIAGRAM	187
FIG. 57 – PRESSURE TRANSDUCERS	134	FIG. 70 – HEAD PRESSURE CONTROL BLOCK DIAGRAM.....	189
FIG. 58 – LEAVING CHILLED LIQUID TEMPERATURE.....	138	FIG. 71 – HEAD PRESSURE FLOW DIAGRAM.....	190
		FIG. 72 – DIAGNOSTICS SCREEN.....	225
		FIG. 73 – MAIN DIAGNOSTICS SCREEN.....	226
		FIG. 74 – I/O DIAGNOSTICS SCREEN	227
		FIG. 75 – KEYPAD TEST SCREEN	229
		FIG. 76 – DISPLAY TEST MAIN SCREEN.....	230
		FIG. 77 – BIT PATTERNS TEST SCREEN	231
		FIG. 78 – SERIAL INPUTS / OUTPUTS TEST SCREEN.....	232
		FIG. 79 – MICROBOARD - COM 5 SERIAL DATA PORT.....	233
		FIG. 80 – DIGITAL INPUTS / OUTPUTS TEST SCREEN.....	234
		FIG. 81 – ANALOG INPUTS TEST SCREEN	237

LIST OF TABLES

TABLE 1 - MICROBOARD 031-01730-000 PROGRAM JUMPERS	33
TABLE 2 - MICROBOARD 031-01730-000 PROGRAM SWITCHES.....	36
TABLE 3 - MICROBOARD 031-02430-000 PROGRAM JUMPERS	54
TABLE 4 - MICROBOARD 031-02430-000 PROGRAM SWITCHES.....	55

SECTION 1 INTRODUCTION

This document explains the operation of the printed circuit boards and major components of the OptiView Control Center to a level that allows a Service Technician to troubleshoot and locate the source of a problem.

The overall system architecture is described and illustrated with block diagrams. This describes the general function of each component and provides the system interface and signal flow. The function of each component and signal flow between components must be understood before effective troubleshooting can commence.

The operation of each printed circuit board is described and illustrated with a block diagram that is a simplified representation of board circuitry. The expected voltage level at all inputs and outputs of each board for any operating condition is provided.

Included in this document are procedures that have to be performed at chiller commissioning or during service. They should not be performed by anyone other than a Service Technician. For example, calibration procedures have to be performed or verified at system commissioning or when a component is replaced. Certain Safety shutdowns require special reset procedures to be performed before the chiller can be restarted. Since the operating program supplied in each OptiView Control Center is universal to all applications, special setpoints, program jumpers and program switches are required to configure the chiller for local operating conditions.

A System Commissioning Checklist is provided as reference of items to be performed during chiller commissioning.

Chillers that are equipped with “P” Compressors have certain component variances. These variances are noted in the appropriate sections of this book.

In addition to this document, several levels of supporting documentation are required while servicing the system. Operations Manual 160.54-O1 explains the operation of the OptiView Control Center Keypad, how to enter Setpoints and explains all the messages displayed on the OptiView Control Center display. 1. The appropriate wiring diagrams for each chiller are shown in the REFERENCE INSTRUCTIONS table in the front of this book. These wiring diagrams provide component interconnections within the Optiview Control Center and the connections between these components and the motor starter and chiller components.

When the chiller shuts down on a **SAFETY** or **CYCLING** shutdown or is being prevented from starting, a message is displayed providing the reason for the shutdown. This message, along with all the chiller operating conditions at the instant of the event are stored in the Microboard battery-backed memory. This history data can be displayed or printed using an optional printer. The Operations Manual 160.54-O1 provides a detailed description of this message, including the conditions required to produce the message and conditions required to restart the chiller.

Diagnostic Routines allow service analysis of the following functions:

- Display
- Analog inputs
- Digital inputs
- Digital outputs
- Serial Data ports

Before beginning any troubleshooting, observe the shut-down message and retrieve the **HISTORY** data of that event. Refer to the Operations Manual for an explanation of the message. The conditions required to produce the message must be clearly understood before proceeding. (If this is not heeded, much time will be wasted). Armed with a knowledge of the overall system architecture and the function of each printed circuit board and signal flow provided by this manual, proceed with the appropriate Wiring Diagram listed above to trace the problem through the system. Use the Diagnostic Routines where appropriate.

SECTION 2

SYSTEM ARCHITECTURE

The OptiView Control Center performs the following functions:

- Controls chiller capacity to chill liquid to the chilled liquid temperature setpoint.
- Controls chiller solenoid valves, relays, actuators and motor contactors per the operating program.
- Displays chiller operating conditions, alarms, shut-down messages and history data.
- Accepts operator-programmed setpoints and controls the chiller accordingly.
- Allows manual control of chiller motor contactors and actuators.
- Monitors chiller operating conditions and shuts down chiller when Safety or Cycling thresholds are exceeded.
- Allows local manual start/stop and accepts start/stop commands from remote devices, via contact closures or serial communications.
- Allows setpoints to be changed from a remote location via 0-10VDC, 2-10VDC, 0-20mA, 4-20mA, contact closures or serial communications.
- Provides chiller operating data and status to remote devices via serial communications and contact closures.
- Allows real-time data and history data to be printed on an optional printer.
- Controls the compressor motor starter and contains a printed circuit board logic that supports Electro-Mechanical Starters, Solid State Starters and YORK Variable Speed Drive.

The OptiView Control Center is a microprocessor based control system that receives analog, digital and serial data inputs and controls analog, digital and serial data outputs per instructions in the operating program. A panel mounted display and touch-sensitive keypad permit local operation.

System pressures are sensed by pressure **transducers**. The output of each transducer is a DC voltage that is analogous to the pressure input. System temperatures are sensed by **thermistors**. The output of each thermistor

is a DC voltage that is analogous to the temperature it is sensing. Typical output voltage range of both is 0.5 to 4.5VDC. These are **analog** inputs to the OptiView Control Center.

Digital Inputs are on/off inputs to the OptiView Control Center in the form of switch and relay contacts. These inputs are 115VAC when the contacts are closed and 0VAC when open. These include flow switches, local start/stop switch, remote cycling and high pressure safety device, etc.

Digital Outputs are on/off outputs from the OptiView Control Center in the form of relay contacts and triacs. The relay contacts typically switch 115VAC and the triacs typically switch a nominal 30VAC. Relay outputs include status/alarm, chiller solenoid valves, oil heater, oil pump starter and chilled and condenser water pump starters, etc. Triac outputs include pre-rotation vane control and variable orifice control.

Serial Data is transmitted to and received from devices in RS-232, RS-485 and TX/RX (opto-couple) form.

The OptiView Control Center supports three types of starters; Electro-Mechanical Starter, Solid State Starter and Variable Speed Drive. However, all OptiView Control Centers contain the following standard components, regardless of the starter type applied:

- Microboard
- I/O (input/output) Board
- Keypad
- Display
- Power Supply

In addition to the standard components, the OptiView Control Center contains a printed circuit board that provides certain control and interface functions for the starter type applied. Each starter type requires a different board as follows:

- Electro-Mechanical Starter - CM-2 Current Module
- Solid State Starter (Style A) – Logic Board
Solid State Starter (Style B) - None
- Variable Speed Drive - Adaptive Capacity Control Board (except those VSD that communicate with the microboard using Modbus protocol).

FIGures 1 through 4 are OptiView Control Center block diagrams of the three starter types. On each block diagram, the standard components are shown, along with the printed circuit board that supports the applied starter type. FIGures 5 and 6 are Operation Sequence timing diagrams of the different starter applications.

The microprocessor and all supporting logic circuits, along with the memory devices containing the operating program, reside on the **Microboard**. All chiller operating decisions are made here. It receives analog and digital inputs from the chiller and remote devices. The analog inputs are connected directly to the Microboard. The digital inputs are received via the I/O Board (see description below). Under Program control, the Microboard operates the relays and triacs that are located on the I/O Board.

The control center will be equipped with one of the following Microboards:

- 031-01730-000 – Shipped in new production chillers until January 2004. The program resides in a replaceable Flash Memory Card. The software version is C.MLM.01.xx.yzz. It is printed on a label adhered to the card. The Program can be upgraded by replacing the card.
- 031-02430-000 – Shipped in new production chillers from January 2004 to June 2006. The program resides in non-removable onboard memory. The software version is C.OPT.01.xx.yzz, and is viewable on the DIAGNOSTICS Screen in SERVICE access level. The Program can be upgraded by downloading a new program from a Program Card. Program Cards are shirt-pocket-size portable memory storage devices available from YORK. This board is backward compatible to YK chillers presently using the 031-01730-000 microboard.
- 031-02430-001 – Shipped in new production chillers after June 2006. This is an upgraded version of the 031-02430-000 microboard. The upgrade is necessary to operate with the Medium Voltage Solid State Starter, Medium Voltage Variable Speed Drive and those Variable Speed Drives and Style B Solid State Starters that serially communicate with the microboard using Modbus Protocol.

The upgrade includes a larger BRAM (U38) and an additional RS-485 port on COM2 serial port for Modbus communications. When used in larger BRAM configuration, requires software version C.OPT.01.15.xxx (or later). This board is backward compatible with YK chillers presently using the 031-01730-000 or 031-02430-000 microboard.

Since the newer versions Microboard are backward compatible to earlier vintage OptiView Control Centers, earlier vintage chillers could be equipped with a later version Microboard due to service replacement.

The software versions (C.MLM.01.xx.yzz or C.OPT.01.xx.yzz) are alphanumeric codes that are interpreted as follows. Each time the controls section or language section is revised, the respective revision level increments.

- C – Commercial chiller
- MLM – Used on Microboard 031-01730-000
- OPT - Used on Microboard 031-02430-000/-001
- 01 – YK chiller
- xx - controls revision level (00, 01, etc)
- y – language package (0=English only, 1=NEMA, 2=CE, 3=NEMA/CE)
- zz – language package revision level (00, 01, etc)

Throughout this manual, reference is made to functions and features that are only available in certain Flash Memory Card revision levels (C.MLM.01.xx.xxx). To cross reference C.MLM software to C.OPT software, refer to the controls revision level. Software version C.OPT.01.09.xxx is of the same controls revision level as C.MLM.01.09.xxx. From this starting point, both receive the same updates at each revision. However, beginning with the release of version C.OPT.01.15.011, C.MLM software will no longer be revised to include new features. Software upgrades should only be performed by a Service Technician.

The **I/O Board** acts as an input/output device for the Microboard. It conditions the digital input signals for the Microboard and contains relays and triacs that are controlled by the Microboard to control solenoids, motor contactors and actuators. The 115VAC digital inputs from switch and relay contacts are converted to logic level voltages by Opto-Couplers. The relays have +12VDC coils that are energized and de-energized by the Microboard. The contacts of these relays control the 115VAC system solenoids, relays and motor contactors. The triacs are turned on and off by the Microboard. The outputs of these triacs control actuators.

Chillers equipped with the Variable Geometry Diffuser are supplied with and require I/O Board 031-01743-002. This board is populated with the required Triacs Q3 and Q4 that apply the open and close signals to the Variable Geometry Diffuser ring actuator. Refer to Variable Geometry Diffuser Section 22A.

A front panel-mounted **Keypad** allows Operator and Service Technician user interface. Membrane keys are used to display chiller and system parameters, enter setpoints and perform chiller and OptiView Control Center diagnostics. It also contains a **START-RUN-STOP/RESET** Switch that is used to locally start and stop the chiller and perform manual reset functions.

A front panel mounted liquid crystal **Display** allows graphic animated display of the chiller, chiller subsystems and system parameters. The chiller and working components of the chiller are displayed, along with chiller operating pressures and temperatures. The Keypad is used to select displays showing increasing levels of detail of chiller working components.

A self-contained **Power Supply** supplies the necessary DC voltages for all the components within the OptiView Control Center.

Chillers equipped with “P” compressors and all style “F” and later chillers have a different Condenser High Pressure Safety Cutout Switch (HPCO) than supplied on other compressor applications. This switch is mounted on the condenser shell but has a different wiring interface to the I/O Board and Motor Controller circuit. Refer to the I/O Board section of this book. Also, “P” compressor applications and style “F” and later chillers with “G, Q” and “H5-8” compressors are equipped with a High Speed Thrust Bearing Limit Switch instead of the Proximity Probe supplied on other compressors. This device detects abnormal bearing position through probe contact instead of distance measurement as performed with the Proximity Probe.

Style C and earlier chillers are equipped with fixed speed oil pumps. Style D and later chillers are equipped with Variable Speed Oil Pumps.

Style F (and later) chillers require Flash Memory card version C.MLM.01.07.xxx and later and are supplied with **factory-mounted Flow Sensors** on the evaporator and condenser. These are electronic thermal-type sensors. The operating principle of the sensor is thermal conductivity. It uses the cooling effect of a flowing liquid to sense flow. The temperature of the heated sensor tip is sensed by a thermistor located in the tip. A second thermistor, located higher in the tip in a non-heated area, is only affected by changes in liquid temperature. The temperatures sensed by the thermistors are compared. Flowing liquid carries heat away from the heated sensor tip, lowering its temperature. The lower temperature differential between the two thermistors indicates the liquid is flowing. A higher differential indicates no flow. These sensors are interfaced to Microboard analog inputs. Refer to the SECTION 3 for a detailed explanation of this flow sensor and interface.

If equipped with Flash Memory Card version C.MLM.01.07.xxx (and later), the chiller Style/Compressor combination must be entered using the **Chiller Style/Compressor Setpoint** (refer to SECTION 23). Once the applicable chiller style/compressor combination is entered, the program automatically bundles the functionality and chiller control per the entered chiller style/compressor requirements. The various chiller style/compressor combinations are equipped differently and have different control requirements. The variables include:

- High Speed Thrust bearing proximity sensing – Proximity Probe or Limit Switch
- Flow Sensor – Paddle type or Factory Mounted Thermal Type. The paddle type applies 115Vac to the I/O Board Digital inputs TB4-12 (evaporator) and TB4-11 (condenser) (refer to FIG. 14). The factory mounted Thermal type (available with Style F and later chillers), applies +5Vdc to the microboard Analog inputs at J7-14 (evaporator) and J7-16 (condenser)(refer to FIG. 12). Flash Memory Card version C.MLM.01.07.xxx and C.MLM.01.07A.xxx automatically selects the Flow Sensor input, either digital or analog per the Chiller Style/Compressor Setpoint selection. Flash Memory Card version C.MLM.01.08.xxx and later allows use of either the Thermal-type or the Paddle-type flow sensors on style F and later chillers. With these versions, the actual flow sensor type present must be entered using the Flow Switch Setpoint (refer to SECTION 23).
- Oil Heater Outputs – Either TB1-34 or TB1-64 on I/O Board

- Refrigerant Level Control Default Period – Either 3.5 seconds or 10.0 seconds
- “Oil – Variable Speed Pump-Pressure Setpoint Not Achieved” safety shutdown threshold – Either 25 PSID or 35 PSID
- Standard Coastdown Time (software version C.OPT.01.16.xxx (and later)) – defaults to either 150 seconds or 240 seconds.

When the compressor motor is driven by an Electro-Mechanical Starter, the OptiView Control center is equipped with a **CM-2 Current Module**. This printed circuit board provides current overload and power fault protection for the compressor motor. Current Transformers, located in the compressor motor terminal box, along with rectifying and calibration circuitry, provide an analog voltage representing compressor motor current to the CM-2 Module. This signal is further conditioned and provided to the Microboard.

When the compressor motor is driven by a YORK Solid State Starter, one of three different Starters could be applied. Later production chillers are equipped with either the Style B Liquid Cooled Solid State Starter (LCSSS) or the Medium Voltage Solid State Starter (MVSSS). The Style B LCSSS (FIG. 3) contains a combination Logic/Trigger Board in the starter cabinet that has a serial communications interface to the microboard. Early vintage Style B LCSSS use an Opto-coupled interface with YORK proprietary protocol. Later vintage Style B LCSSS (after mid 2008) use Modbus protocol (requires software version C.OPT.01.18.307 or later). The Medium Voltage Solid State Starter (FIG. 3A) serially communicates with the microboard using RS-485 Modbus Protocol. Earlier vintage chillers are equipped with the Style “A” Solid State Starter. This starter contains a Trigger Board that interfaces to a Logic Board that is installed inside the OptiView Control Center. The Logic Board interfaces the Microboard via a multiplexed data interface.

When the compressor motor is driven by a YORK Variable Speed Drive, there could be a Variable Speed Drive (VSD) or a Medium Voltage Variable Speed Drive (MV VSD) applied. Early vintage VSD’s (FIG. 4) contain an Adaptive Capacity Control (ACC) Board that resides in the OptiView cabinet that interfaces the microboard using YORK proprietary protocol serial opto-coupled communications. The ACC board monitors system parameters and controls the VSD to drive the compressor at the slowest speed without surging, while maintaining required chiller capacity. With the later vintage VSD (FIG. 4A), the ACC functionality resides in the microboard,

the ACC Board is not present and the VSD Logic Board directly interfaces the microboard using RS-485 Modbus Protocol serial communications. The MV VSD (FIG. 4B) is also interfaced to the microboard with RS-485 Modbus serial communications. All Modbus protocol applications require software version C.OPT.01.16.xxx (or later).

Serial data interface to the YORK ISN Building Automation System is through the optional MicroGateway. This printed circuit board requests the required data from the Microboard and makes it available for the ISN network.

Certain compressors are equipped with a **Variable Geometry Diffuser** (VGD). It is used to reduce rotating stall conditions and associated stall noise. Stall may occur at low load conditions with high head. A mechanical ring, located in the compressor diffuser passage is operated to open or close the diffuser gap. Stall noise is detected as gas pressure pulsations. A **Stall Pressure Transducer**, mounted in the discharge scroll of the compressor, detects the gas pressure pulsations and outputs DC voltage pulsations to the **Stall Detector Board**. This board converts the voltage pulsations into an analog voltage that represents the magnitude of the stall noise. This analog voltage is input to the Microboard where it is compared to thresholds that determine if the stall noise is acceptable or unacceptable. The VGD is pulsed toward the closed position in response to unacceptable stall noise. Otherwise, it is modulated to maintain the most open position possible without stall occurring. Software version C.MLM.01.10.xxx (and later) or C.OPT.01.10.302 (and later) and I/O Board 031-01743-002 is required for this feature. A Pre-rotation Vanes position potentiometer is also required to support this feature. If the chiller is provided with a compressor motor Variable Speed Drive or the optional Hot Gas Bypass, the PRV potentiometer for those features is used. Otherwise, a PRV potentiometer is provided interfaced to the Microboard.

After July 2009, chillers that are equipped for the Hot Gas Bypass, Heat Recovery or Head Pressure Control options are equipped with a Large Tonnage Chiller (LTC) I/O Board. This board provides for analog and digital inputs and outputs for these features and it communicates with Microboard 031-02430-00/001 COM3 RS-RS-485 serial port using Modbus protocol.

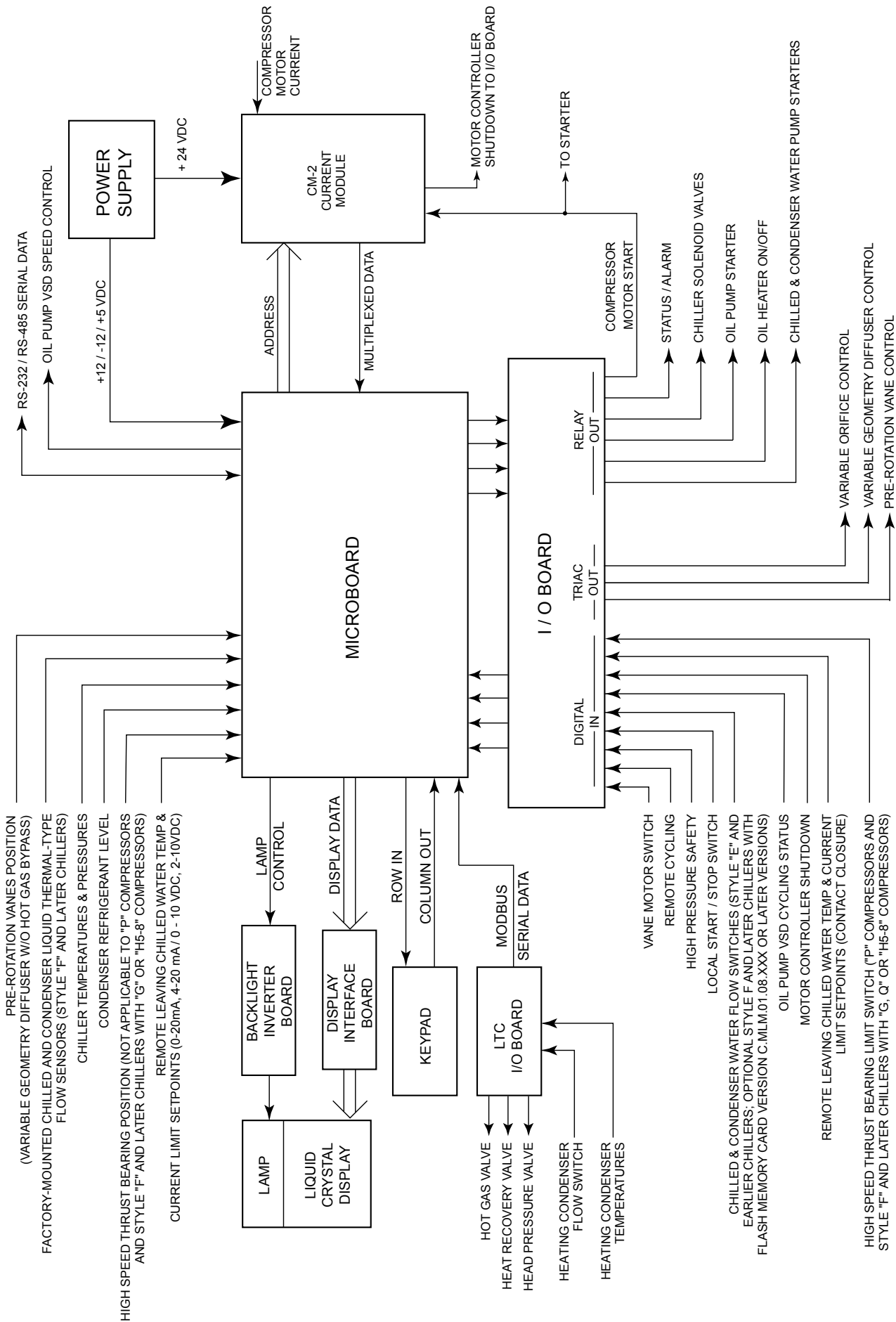

FIG. 1 – OPTIVIEW CONTROL CENTER - ELECTRO-MECHANICAL STARTER APPLICATIONS

LD09559a

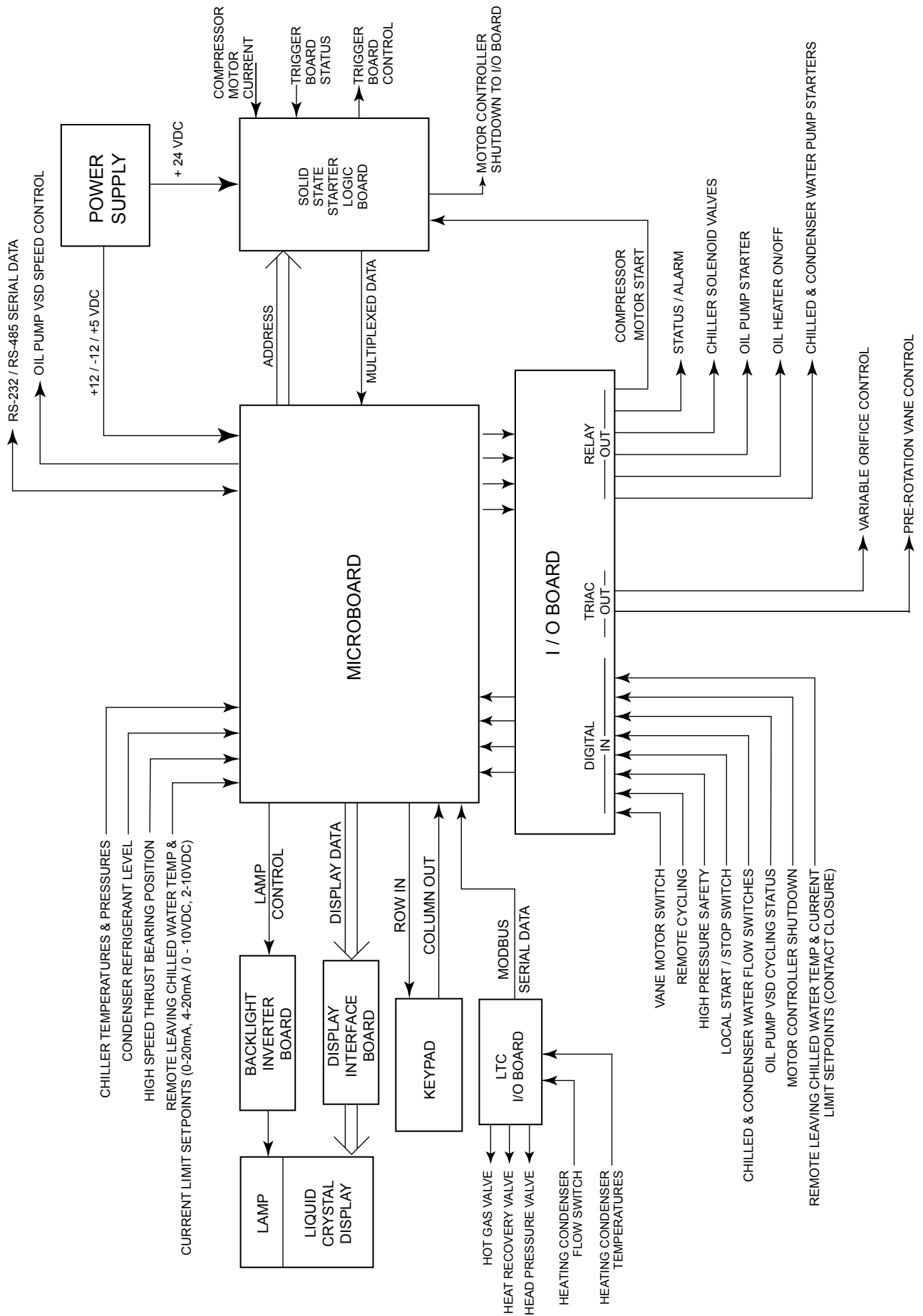

FIG. 2 – OPTIVIEW CONTROL CENTER - MOD "A" SOLID STATE STARTER APPLICATIONS

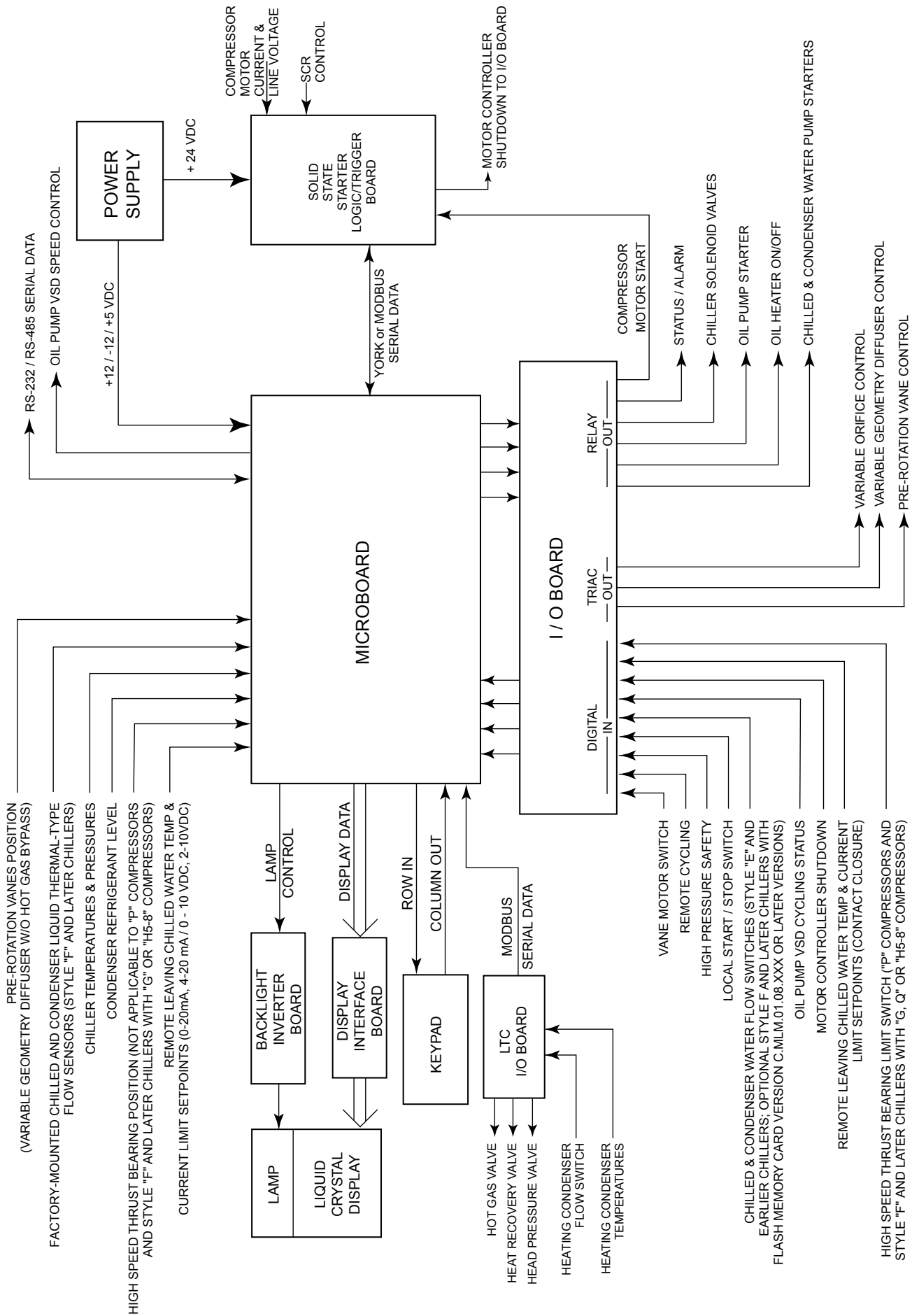
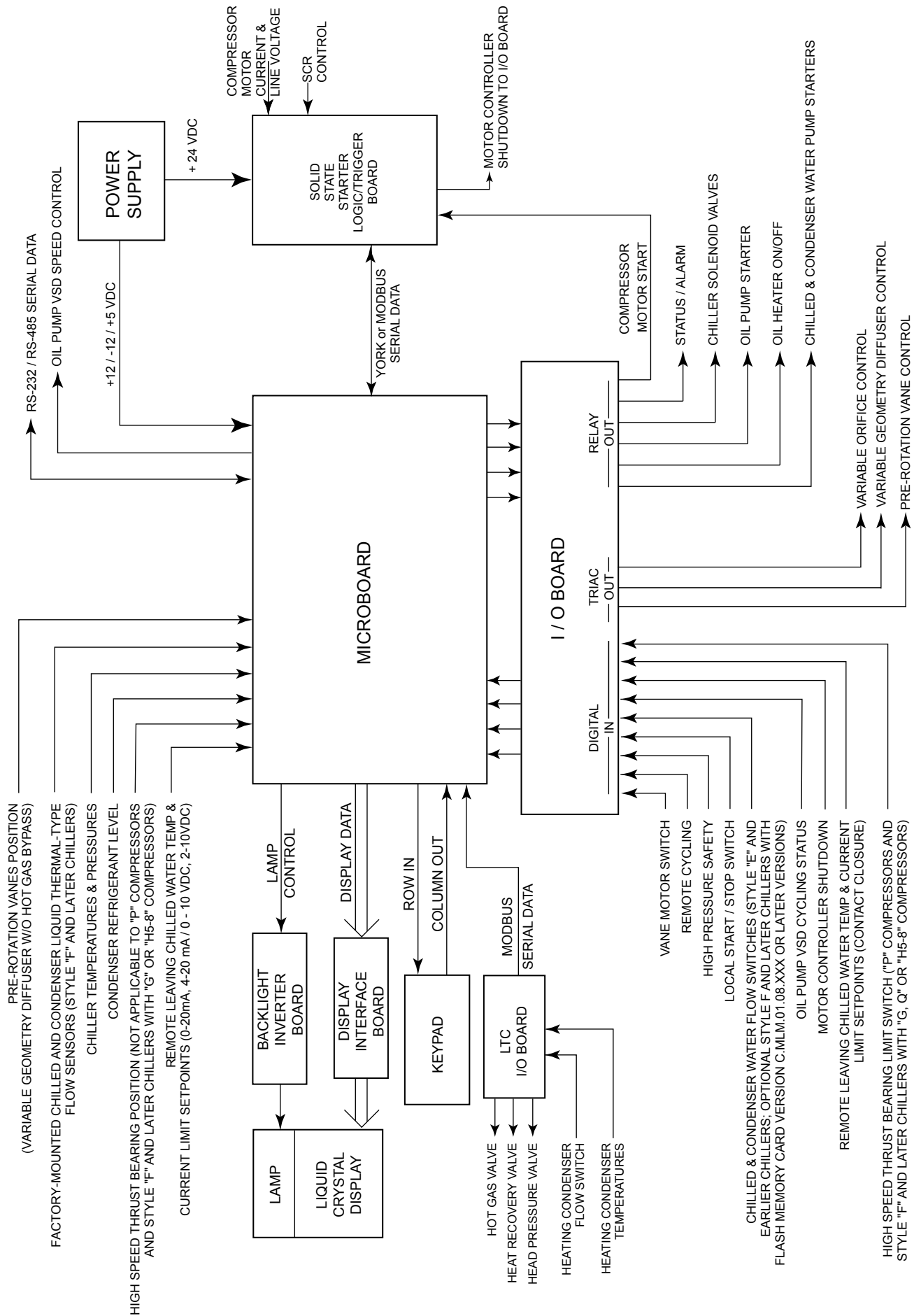
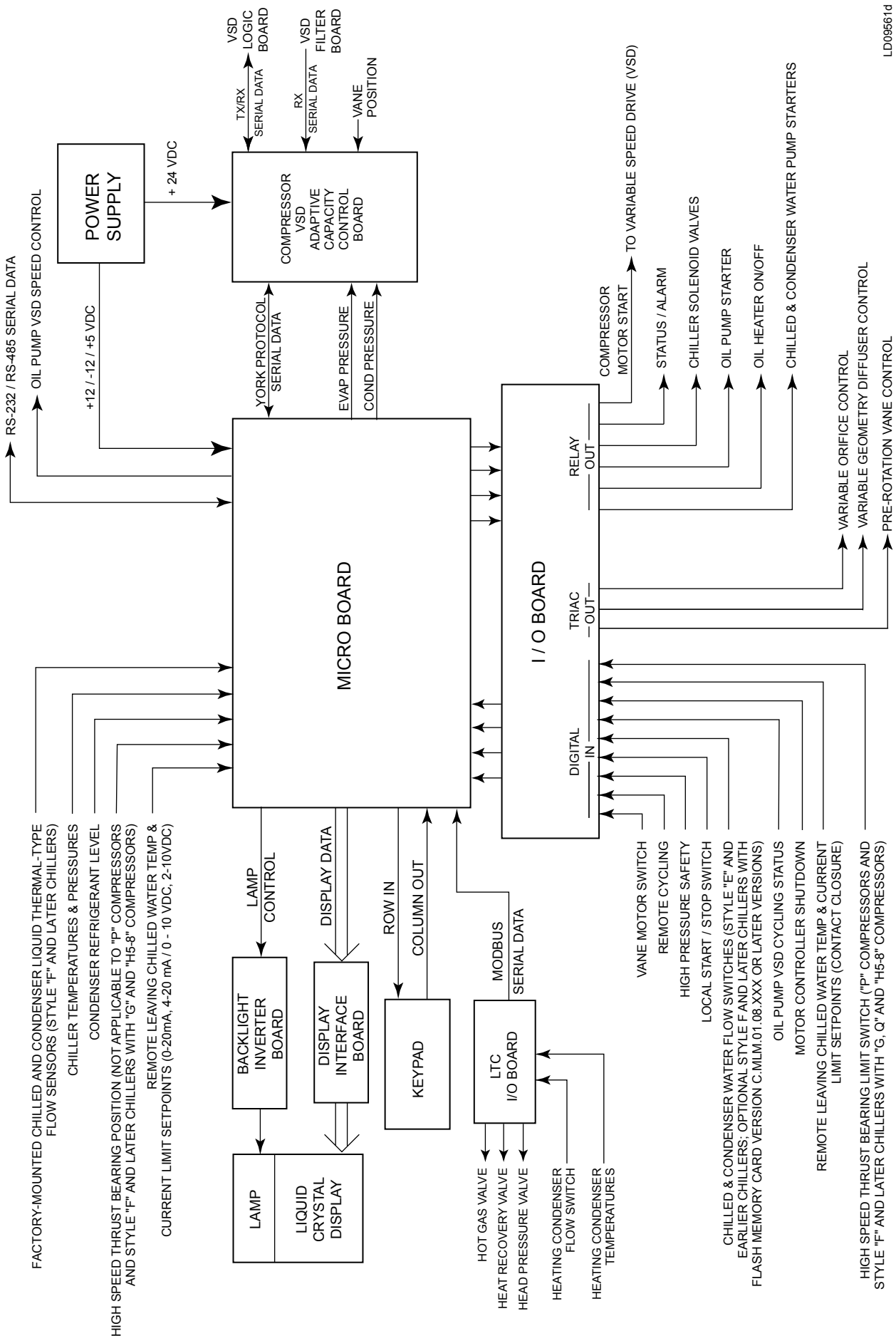

FIG. 3 – OPTVIEW CONTROL CENTER - MOD "B" SOLID STATE STARTER APPLICATIONS

LD09560c



17 **FIG. 3A – OPTVIEW CONTROL CENTER - MEDIUM VOLTAGE SOLID STATE STARTER APPLICATIONS**



LD09561d

FIG. 4 – OPTIVIEW CONTROL CENTER - COMPRESSOR MOTOR VARIABLE SPEED DRIVE (YORK SERIAL COMMUNICATIONS PROTOCOL)

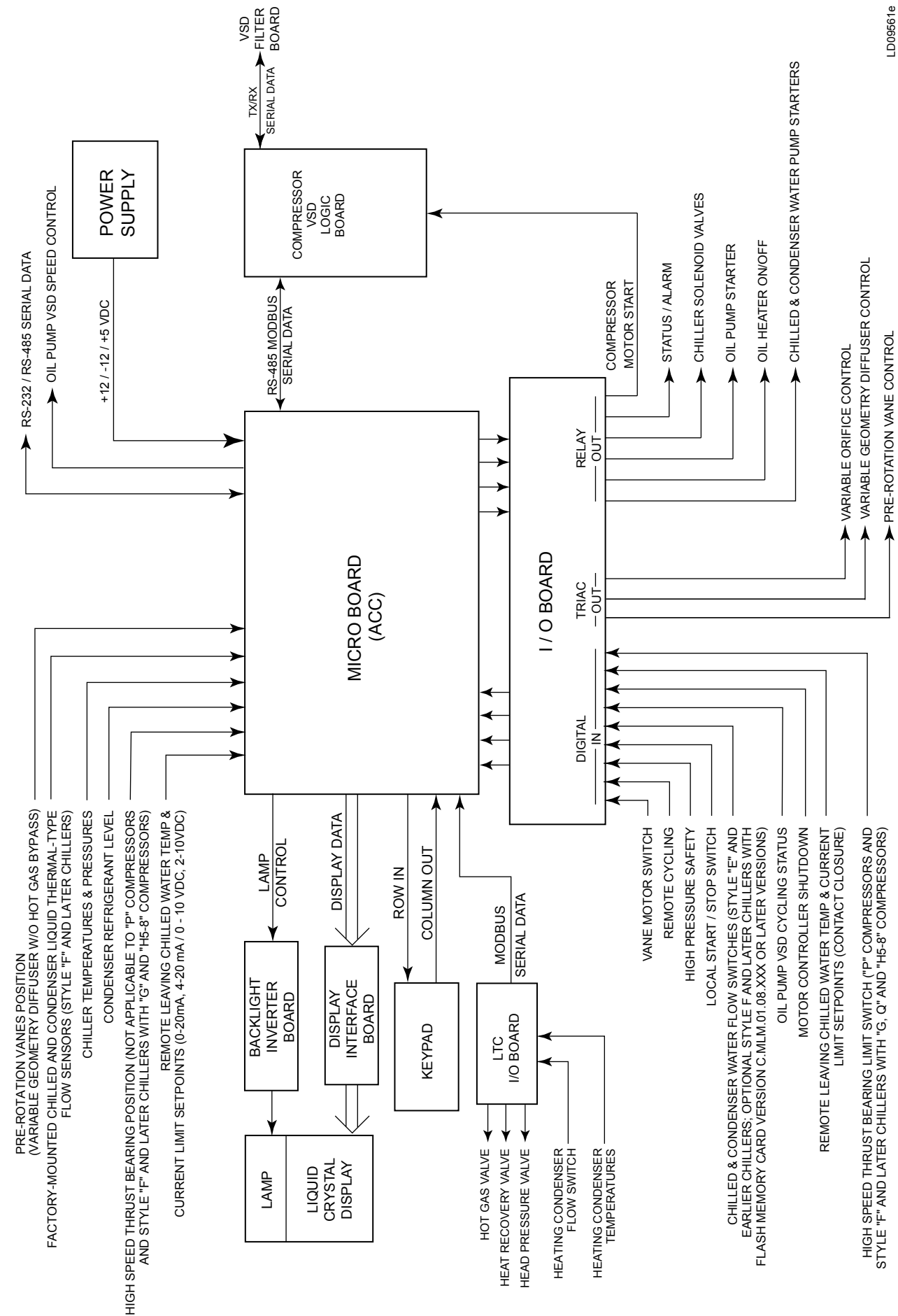

LD09661e

9 **FIG. 4A – OPTIVIEW CONTROL CENTER - COMPRESSOR MOTOR VARIABLE SPEED DRIVE (MODBUS SERIAL COMMUNICATIONS PROTOCOL)**

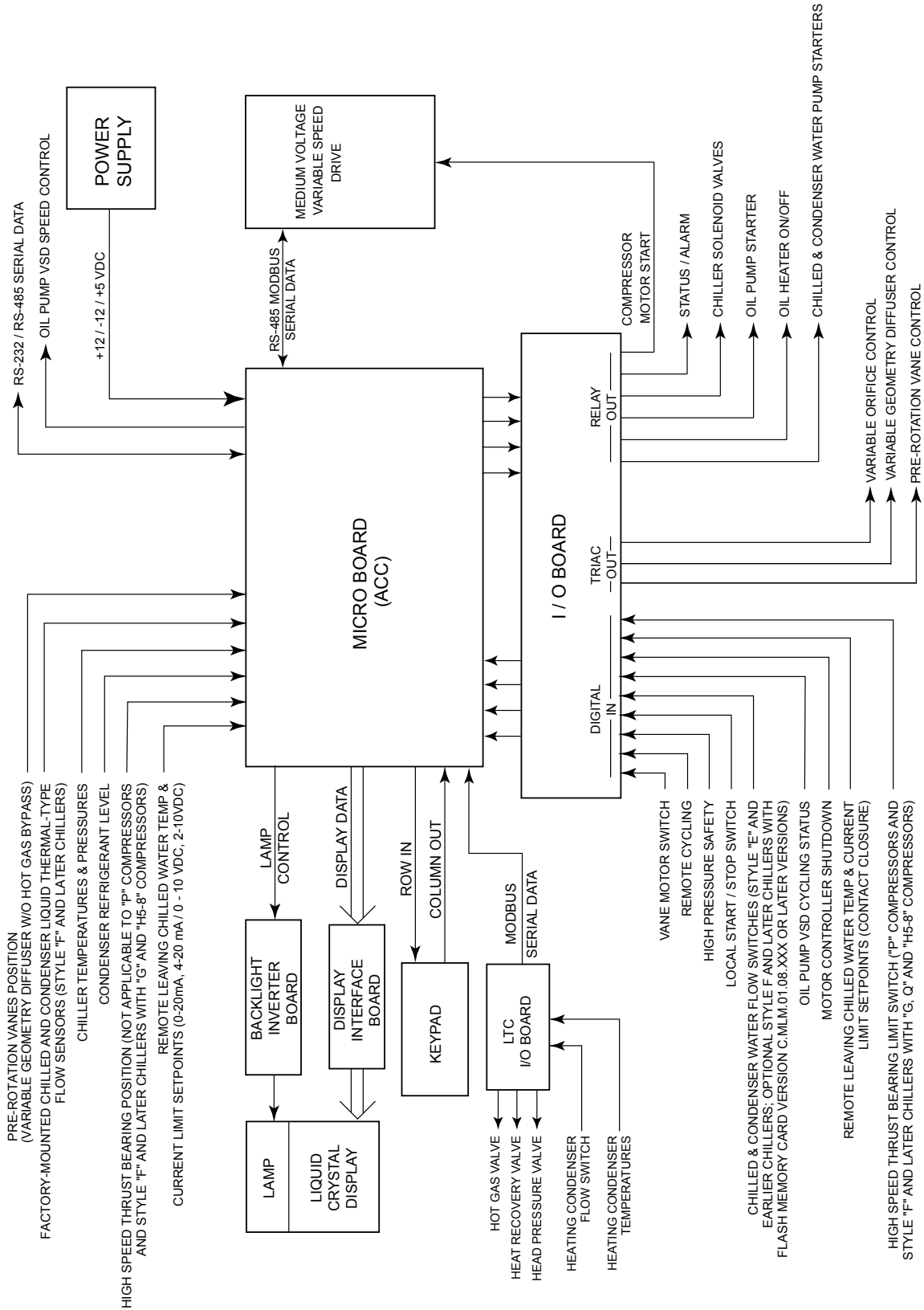
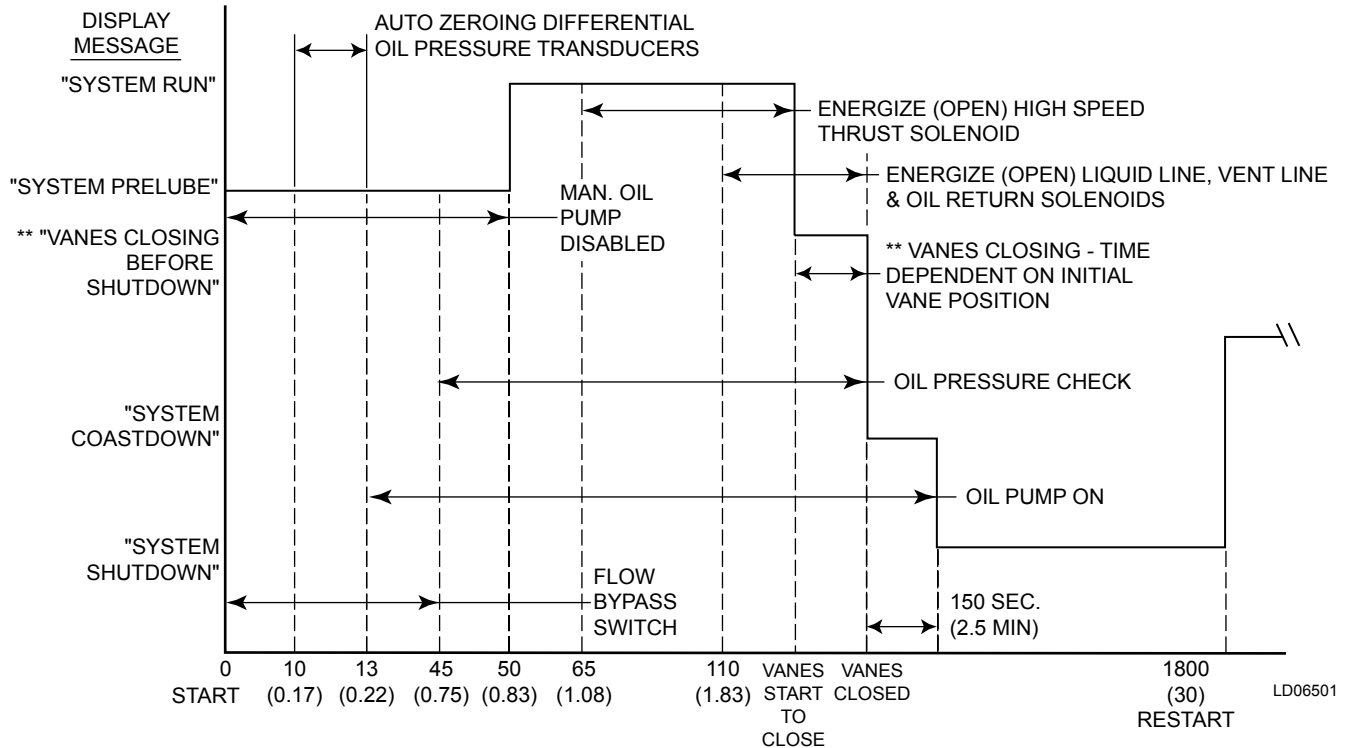

FIG. 4B – OPTIVIEW CONTROL CENTER - COMPRESSOR MOTOR MEDIUM VOLTAGE VARIABLE SPEED DRIVE

TIMING DIAGRAM – CHILLERS EQUIPPED WITH FIXED SPEED OIL PUMP (STYLE C)



TIME IN SECONDS (MINUTES)

**Only applicable to the following shutdowns. When any of these shutdowns are performed, the vanes are driven fully closed before the starter is de-energized. When the vane motor switch closes (or 210 seconds from start of vane closure have elapsed), the starter is de-energized. 1. Low Water Temperature; 2. Multi-Unit Sequence (TB4-9); 3. Remote/Local Cycling (TB4-13); 4. Internal Time Clock; 5. Remote Stop (TB4-8); 6. Remote Stop (ISN Serial Port). Operator initiated Soft Shutdown (Flash Memory Card version C.MLM.01.06.xxx and later or C.MLM.04.02.xxx)

TIMING DIAGRAM – CHILLERS EQUIPPED WITH VARIABLE SPEED OIL PUMP (STYLE D/E/F)

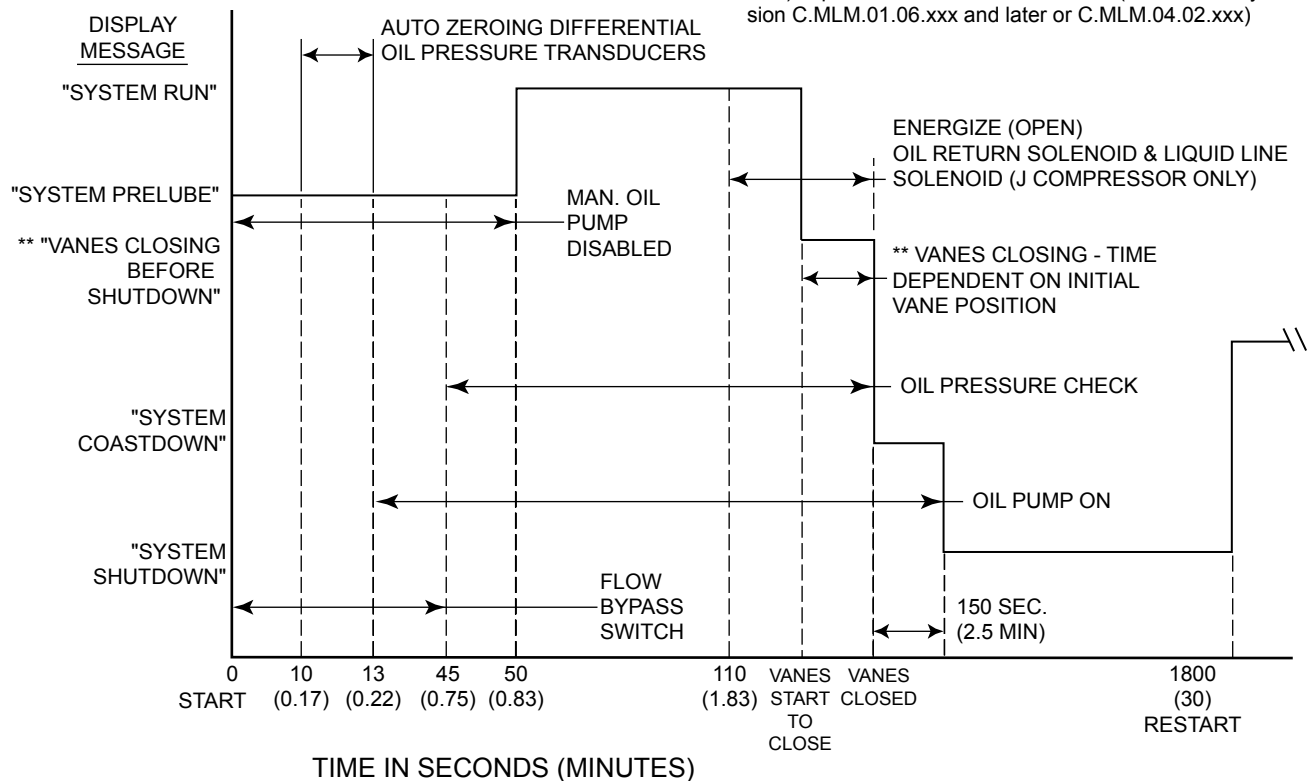

TIME IN SECONDS (MINUTES)

FIG. 5 – OPERATION SEQUENCE TIMING DIAGRAM (ELECTRO-MECHANICAL & SOLID STATE STARTER APPLICATIONS)

TIMING DIAGRAM – CHILLERS EQUIPPED WITH FIXED SPEED OIL PUMP (STYLE C)

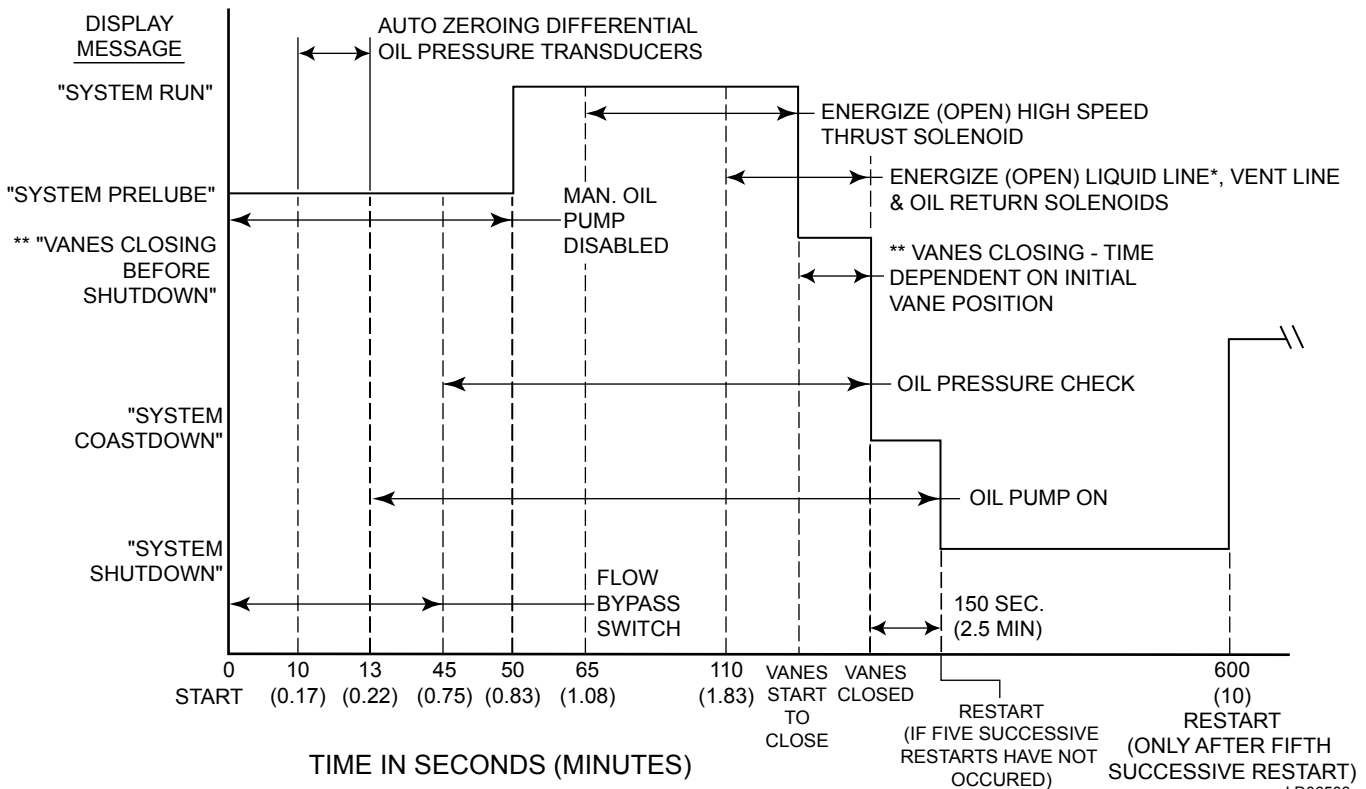

* The Liquid Line solenoid will only be energized during this period when the oil temperature reaches > 140°F. It will then be de-energized when the temperature is < 135°F.

TIMING DIAGRAM – CHILLERS EQUIPPED WITH VARIABLE SPEED OIL PUMP (STYLE D/E/F)

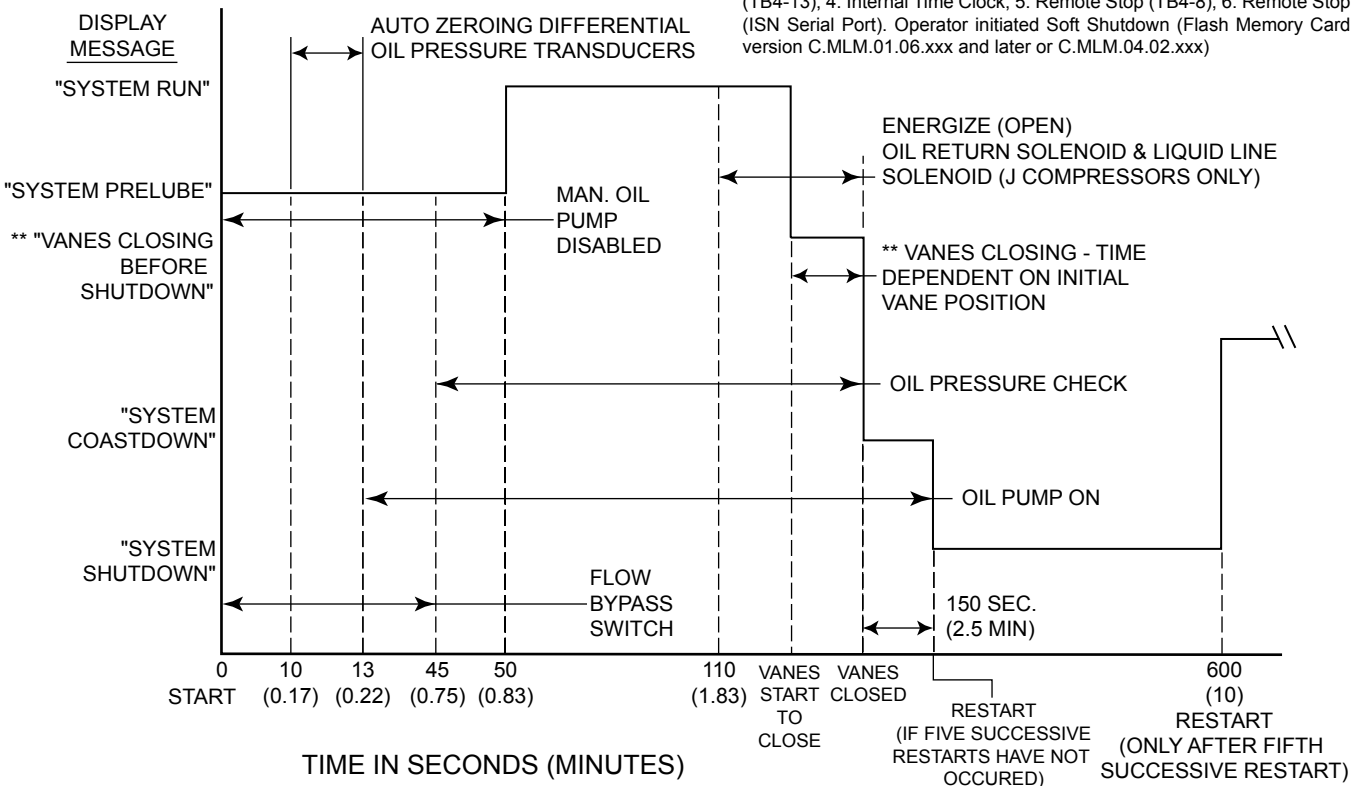

**Only applicable to the following shutdowns. When any of these shutdowns are performed, the vanes are driven fully closed before the starter is de-energized. When the vane motor switch closes (or 210 seconds from start of vane closure have elapsed), the starter is de-energized. 1. Low Water Temperature; 2. Multi-Unit Sequence (TB4-9); 3. Remote/Local Cycling (TB4-13); 4. Internal Time Clock; 5. Remote Stop (TB4-8); 6. Remote Stop (ISN Serial Port). Operator initiated Soft Shutdown (Flash Memory Card version C.MLM.01.06.xxx and later or C.MLM.04.02.xxx)

FIG. 6 – OPERATION SEQUENCE TIMING DIAGRAM (COMPRESSOR MOTOR VARIABLE SPEED DRIVE APPLICATIONS)

LD06504

SECTION 3 MICROBOARD 031-01730-000 (REFER TO FIG. 7 - 12)

Microboard 031-01730-000 is supplied in new production chillers until January 2004.

The **Microboard** contains the operating software (Program), microprocessor (Micro), and supporting circuits for the Micro.

The **Program** is a set of instructions to control the chiller, the display and peripheral devices. It also contains the Safety and Cycling shutdown thresholds (non changeable) and Display messages and screens. It is stored in a memory device called a **flash memory card**. This is a type of non-volatile memory that can be read from or written to, but requires the locations to be erased before they are written to. With the exception of a write/read sequence that occurs during the Boot-up process explained below, this device is used primarily as read-only in this application. A write protect switch is located on the left edge of the card as shown in FIG. 8. It must be placed in the “Write Enabled” position in order to allow successful Boot-up. The card is located in socket location U46 (Ref. FIG. 7). It connects to the Board via an Elastomeric connector that is a silicon rubber strip embedded with silver conductors. The Card can be removed from its socket by using the thumb to press down on the socket’s plastic tension spring. The card is installed by inserting it into the socket/holder and pressing on the surface of the Card until it snaps into place. The Memory card is a replaceable component. Refer to YORK Renewal Parts List Form 160.54-RP1. The version of the Memory card is an alpha-numeric code that represents the application and revision level. The version is printed on a label adhered to the memory card’s surface. The version code is as follows:

C.MLM.nn.nn.nnn

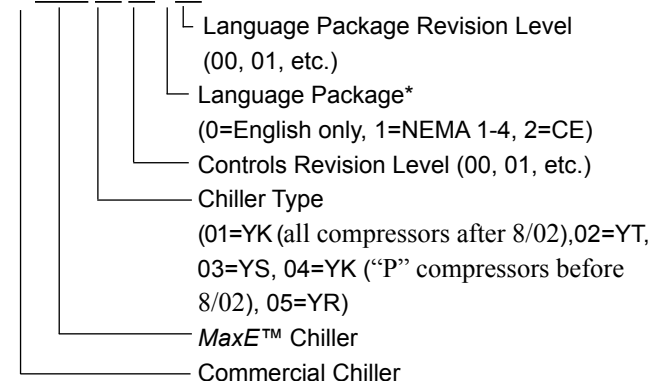

* Refer to YORK Renewal Parts List 160.54-RP1 for available languages.

1 = Supplied in new NEMA 1-4 OptiView Control Centers but can be retrofit to any OptiView Control Center.

2 = Supplied in new CE (European Community) OptiView Control Centers but can be retrofit to any OptiView Control Center.

There are two Flash Memory Cards available. The difference between them is the different languages that can be displayed on the Display Screens. Language selection is performed on the USER Screen following instructions in Operations Manual 160.54-O1. Not all languages are available. Refer to Renewal Parts List 160.54-RP1 for list of available Flash Memory Cards and display languages. **IMPORTANT!** – Not all versions of Flash Memory Cards are compatible with revision “E” (and later) Microboards or all BIOS Eproms. If an incompatible version is used, the initialization (boot-up) process will not complete and the chiller will not run! Refer to Renewal Parts List 160.54-RP1 and “Service Replacement” paragraph in this section.

Flash Memory Cards are revised to add new features, enhancements and program corrections. Each time they are revised, the revision level of the affected portion of the program (controls or language) increments. Each time they are revised, a Service Information Bulletin is issued that describes the new features. Those bulletins that have been issued to date, are located at the rear of this manual.

The **Micro** controls the chiller by reading and executing the Program instructions in a sequence determined by the Program. Under Program control, the Micro reads the Analog and Digital Inputs to determine the operating conditions and controls Digital Outputs based upon these inputs. These inputs are compared to stored thresholds to determine if a Safety or Cycling shutdown is required. If a threshold has been exceeded, a shutdown is performed and the appropriate message is retrieved from the Program and displayed on the Liquid Crystal Display. As operating conditions require, status messages are retrieved and displayed. The Keypad is read as Digital Inputs. When an operator presses a key to request a display, the Micro interprets the request, retrieves the display from the Program and displays it. The Program assembles data in the correct format for transmission through the Serial Data Ports to peripheral devices. The Program also instructs the Micro to respond to requests from peripheral devices for serial data transmissions.

The **Watchdog** circuit monitors the +5VDC supply from the external Power Supply to determine when a power failure is occurring. Just prior to the supply decreasing to a level where the Micro and supporting circuits can no longer operate, it applies a reset signal to the Micro. The Micro responds by de-energizing the run digital output through the FPGA, shutting down the chiller and retrieving the **Power Failure** message from the Program and sending it to the Display Controller for display. Similarly, when power is first applied after a power failure, it maintains the Micro in a reset state until the +5VDC has returned to a sufficient level. The Watchdog circuit also assures that all the Program instructions are being performed and that the Program has not latched-up, bypassing important safety thresholds. If the Program has latched-up, The Micro initiates a Safety shutdown and displays **WATCHDOG – SOFTWARE REBOOT** message.

The **BIOS EPROM** (basic input/output system erasable programmable read only memory) is a memory device that contains the bootstrap or power-up program. It is located in socket location U45. This EPROM is replaceable. Refer to YORK Renewal Parts List Form 160.54-RP1. The EPROM version is an alpha-numeric code that represents the application and revision level. The version is printed on a label adhered to the EPROM's surface. The version code is as follows:

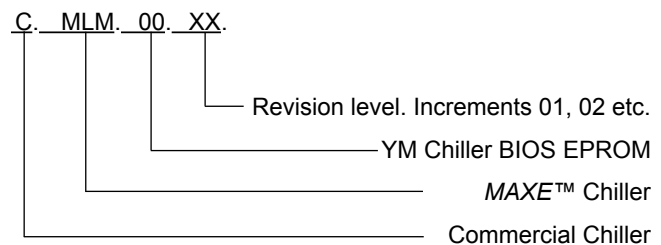

Early vintage chillers were equipped with BIOS eprom 031-01796-001. This eprom is no longer used. It has been superseded by BIOS eprom 031-01796-002. **IMPORTANT!** Eprom 031-01796-002 is not compatible with all versions of Flash Memory Cards. Refer to Service Replacement paragraphs in this section.

When power is applied to the OptiView Control Center following a power failure, the Micro executes the instructions in the BIOS EPROM program to initialize, configure and start operation of certain Microboard components before the main program (stored in the Flash Memory Card) is started. Depending upon the application, the Microboard could be equipped with an EPROM that has either 128K, 256K or 512K capacity. Microboard Program Jumper JP38 must be positioned according to the actual EPROM installed. Refer to Table 1 (Program Jumpers). There are 5 steps to the boot-up process. During the boot-up process, there is a visual indication as each step is performed, followed by a Pass/Fail status of the step. On the Microboard, a green LED (CR17 - Pass) flashes to indicate the step was successful. If a step is unsuccessful, a red LED (CR18 - Fail) flashes and the Boot-up process terminates. The execution and Pass/Fail status of steps 3 through 5 are displayed on a white Keypad Display Screen as they are performed. This white display screen also lists the BIOS EPROM Version. The steps of the Boot-up process are as follows. Also, below is listed the LED activity associated with each step.

BOOT-UP STEP AND DESCRIPTION

1. First initiate table complete.

Registers in the Micro are configured to allow it to perform basic memory read/write functions.

2. FPGA configuration.

The Field Programmable Gate Array (FPGA) is configured to process Digital Inputs and Outputs.

3. Mini-card signature test.

A location in the Flash Memory Card that contains a code identifying the Manufacturer is compared to other locations that contain the manufacturer's name. If these values are the same, it is **pass**. If they are different, it is **fail**.

4. Mini-card checksum.

The **Flash** Memory Card checksum is calculated and compared to the checksum value that is stored in the Card at the time the Card was initially programmed at the YORK factory. If both values are the same, it is considered **pass**. If the calculated value is different than the stored value, it is considered **fail**.

5. BRAM quick test.

Test data is written to and then read from several memory locations to verify BRAM operation.

LED Indicators

When power is applied to the OptiView Control Center, both the red (CR18 - Fail) and green (CR17 - Pass) LEDs simultaneously illuminate for 1 second, then the Boot-up process begins in the following sequence.

STEP	PASS	FAIL
1	Green on, Red off	Watchdog will initiate a re-boot.
2	Green flash once	Boot-up process halts. One red flash repeating
3	Green flash once	Boot-up process halts. Two red flashes repeating
4	Green flash once	Boot-up process halts. Three red flashes repeating
5	Green flash once	Boot-up process halts. Four red flashes repeating

When all steps have been completed, the LED's will then illuminate or extinguish, as long as power is applied, according to the settings of Microboard Program Switches 7 and 8 as follows:

Green (CR17)

Program SW 7 set to 50 Hz – extinguishes
60 Hz – illuminates

Red (CR18)

Program SW 8 set to Standard – illuminates
Enhanced – extinguishes

The **BRAM** (battery backed random access memory) is a memory device that contains a battery that preserves the data during power failures. It is a replaceable part. Refer to YORK Renewal Parts List Form 160.54-RP1. It is located in socket location U52. The Micro stores the setpoints programmed by the Operator or Service Technician, History Data and other data that requires preservation, in this device. Also, the day of week, time of day and calendar date time-keeping are done here.

Program Jumpers/Program Switches

The Program Jumpers (Table 1) and Program Switches (Table 2) are used to alter the program operation or configure the Microboard hardware for specific operation. This allows the Program and Microboard to be universal for all standard applications. Refer to Table 3 and 4 for the function of each jumper and switch. The position of some jumpers can be determined by the Service Technician to meet the desired operation. Others must be positioned according to the requirements of the size, type or style of components and thus are determined by the YORK factory. Some jumpers are plastic sleeves with metal inserts that are inserted over 2-prong or 3-prong conductors. Others are wire bridges that are either cut or left in place. The Program Switches are miniature switches that are placed in either the ON or OFF position.

Keypad Interface

The Keypad is read via J18. The Keypad is a matrix of conductors arranged in rows and columns (ref FIG. 32 and 33). There are 4 rows and 8 columns. When a key

is pressed, the conductors are pressed together at that point, creating continuity between the row conductor and the column conductor. The keypad is read by applying a logic low to a row while leaving +5vdc pullup on all other rows. The micro then reads the 8 columns. If any column has a logic low on it, the key corresponding to that coordinate (row, column) is being pressed. The micro reads the entire keypad by repeating this routine beginning with row 1 and ending with row 4. The entire keypad is continually read while the control center is powered. Refer to SECTION 8 of this manual for details of the Keypad.

CM-2 Board or Style A Solid State Starter Interface

The microboard retrieves certain operating parameters (via J10) from the compressor motor starter control board (CM-2 Current Board for Electromechanical starter or Style “A” Solid State Starter Logic Board). Refer to the appropriate section of this book for detailed explanation of each board. Both boards contain an 8 channel multiplexer. The micro sequentially and continually reads channels 0 through 7. It reads each channel by applying a 3-bit binary address to the multiplexer. A 0-5vdc analog value is returned from each channel. The function of each is in the table below. The micro determines which board, and therefore which starter is present, by the value returned from channel 0. Since channels 0 through 6 are grounded, the CM-2 board returns a 0vdc value. The Solid State Starter Logic Board returns a value >0.41vdc to +5vdc. If the value is <0.4vdc, it indicates the starter is an Electro-mechanical (EM) starter and the micro then reads channel 7 to retrieve the peak motor current value. A value >0.4vdc indicates the starter is an “A” style Solid State Starter and the micro reads channels 1 through 7. In the Solid State Starter, channel 0 indicates the starter size (model) and voltmeter range (300Vac or 600Vac). Channel 1 is a hardware generated 100% FLA (prevents pre-rotation vanes from further opening) or 104% FLA (closes pre-rotation vanes until motor current is <102%) current limit override command that overrides normal Pro-rotation Vanes control. Channels 2 through 4 are analog voltages that represent phase A, B and C motor current. The highest phase is Channels 5 through 7 are analog voltages that represent phase A, B and C Line Voltage. The data for each channel is shown below:

The addresses and associated data are shown below:

CM-2 Board		Mod “A” Solid State Starter Logic Board	
Address	Data	Address	Data
0 thru 6	Gnd	0	starter model / voltmeter range
7	Peak Motor Current	1	current limit command
		2 - 4	phase C, B, A motor current
		5 - 7	phase A, B, C line voltage

Style B Solid State Starter or Variable Speed Drive Interface

If equipped with either of these drives, the drive is interfaced to the Microboard via the Opto-Coupled COM 5 serial data port (J15). The serial data is represented by +5vdc and 0vdc logic levels. J15-1 is TX data to the drive and J15-2 is RX data from the drive. Refer to SECTION 11 (Solid State Starter) and SECTION 12 (VSD) for details of this interface.

Printer Interface

An optional Printer can be connected to COM1 RS-232 serial data port (J2). J2-4 is TX data to the printer. J2-2 is the DSR (Data Set Ready or busy) signal from the printer. Signal levels are standard RS-232. The microboard sends data to the printer at the selected baud rate until the printer buffer becomes full, whereupon the printer asserts its Busy signal. The microboard suspends data transmission until the printer can accept more data. Each printer must be setup/configured to operate properly with the microboard. The Baud, Data Bits, Parity and Stop Bits must be programmed on the Comms Screen. Other printer setup is performed on the PRINTER Screen. Refer to YORK manual 160.55-01 for details of available printers and printer setup instructions.

MicroGateway Interface

An optional Microgateway printed circuit board can be connected to the COM 4B RS-232 serial data port (J2). J2-7 is TX data to the MicroGateway. J2-6 is RX data from the Microgateway. Signal levels are standard RS-232. The MicroGateway polls system pressures, temperatures and status from the microboard. It holds it for retrieval by third-party devices. Refer to SECTION 15 of this manual.

Digital Inputs

The I/O Board converts the 115Vac inputs to logic level inputs for the microboard at J19. A 115Vac input to the I/O board is converted to a logic low (<1Vdc). A 0Vac input to the I/O Board is converted to a logic high (>4Vdc). Refer to SECTION 4 of this manual for details of the I/O Board.

Digital Outputs

The microboard controls 115vac relays and solenoids via the I/O Board (via J19). The I/O Board contains +12Vdc relays that isolate the microboard low voltage circuits from the 115Vac device coils. Solid state switching devices are used to control the relays. The microboard energizes the +12Vdc relays by applying a ground to the coil input. They are de-energized by opening the ground path. The contacts of these relays switch 115Vac to system relays and solenoids. The outputs that control the chilled liquid pump and compressor motor starter have anti-chatter (anti-recycle) timers associated with them. The output that controls relay K0 is not allowed to change at a rate greater than once every 10 seconds. The output that controls relay K13 is not allowed to change at a rate greater than once every 20 seconds.

The microboard controls Actuator motors via Triacs on the I/O Board. Each actuator has an open winding and a close winding. Current flowing through a winding causes the actuator to rotate in the respective direction. Each winding is controlled by a Triac. The Triac is turned on to allow current to flow through a winding. The microboard turns on the Triac by applying a logic low (<1Vdc) to the Triac driver on the I/O Board. It turns it off by applying a logic high (>4vdc). Refer to SECTION 4 of this manual for details of the I/O Board.

Analog Inputs

System pressures, in the form of analog DC voltages, are input from Pressure Transducers. Refer to SECTION 16 of this manual. Formulas and graphs are included to calculate the expected transducer output voltage for a given pressure input.

System temperatures, in the form of analog DC voltages, are input from Thermistors. Refer to SECTION 17 of this manual. Included are tables to convert the expected output voltage for any temperature applied to the thermistor.

Style F (and later) chillers are supplied with factory-mounted Flow Sensors on the evaporator and condenser (Software version C.MLM.01.07.xxx (and later) is required for this feature. These are electronic thermal-type sensors. The operating principle of the sensor is thermal conductivity. It uses the cooling effect of a flowing liquid to sense flow. The temperature of the heated sensor tip is sensed by a thermistor located in the tip. A second thermistor, located higher in the tip in a non-heated area, is only affected by changes in liquid temperature. The temperatures sensed by the thermistors are compared. Flowing liquid carries heat away from the heated sensor tip, lowering its temperature. The higher the flow rate, the lower the tip temperature and therefore a lower differential between thermistors. Lower flow rates remove less heat from the tip allowing a higher tip temperature. The lower the flow, the greater the differential between thermistors. The sensor is vendor-calibrated to turn on its output at a flow rate of 20cm(0.6 ft.)/second. This is the setpoint. There are 11 LED's on the sensor that reflect the measured flow rate. The center located amber LED illuminates at the setpoint flow rate (and above). The 4 LED's to the left of the amber reflect flow rates below the setpoint. The 6 LED's to the right of the amber reflect flow rates above the setpoint. As the flow rate decreases from the setpoint, the LED display moves to the left. As the flow rate increases above the setpoint, the LED display moves to the right. The sensor operates from a 24Vac power source and has a solid state relay output. On each sensor, one side of the solid state relay output (pin 2) is connected to the microboard +5Vdc and the other side (pin 4) is Connected to a microboard analog input (refer to FIG. 12). After power is applied, there is a thermal warm-up period of up to 20 seconds. During this time, the output could be unstable. When the setpoint (or greater) flow rate is sensed, the solid state relay output is turned on causing it to conduct current through the 7.5K ohm microboard load resistor to the +5vdc. This applies >+4Vdc to the microboard input evaporator J7-14; condenser J7-16). When a flow rate less than the setpoint is sensed, the solid state relay output is turned off, resulting in no conduction through the load resistor. This applies <1Vdc to the microboard input. To determine the state of the solid state relay, first confirm that +5vdc is present at pin 2 of the flow sensor. Then connect a voltmeter from Microboard J7-14 (evaporator) or J7-16 (condenser) to microboard TP1(ground). Software version C.MLM.01.08.xxx (and

later) allows either the Thermal-Type sensors connected to the Microboard analog inputs or the Paddle-Type sensor connected to the I/O Board digital inputs (refer to the Flow Switch Setpoint in SECTION 23). To assure the program reads the correct input for the flow sensor type present, the Chiller Style/Compressor Setpoint and Flow Switch Setpoint must be set appropriately (refer to SECTION 23).

Serial Data Ports

The Microboard is equipped with 5 serial data ports (ref fig 11). Each port is dedicated for a specific function as follows:

- a. COM1 (J2) – RS-232. Printer
- b. COM2 (J13) – RS-232. Not used
- c. COM3 (J12) – RS-485. Optional I/O.
- d. COM4 (4A-J11), (4B-J2) – This port is actually two ports. However, they cannot be used simultaneously. The position of program jumper JP27 determines which port can be used. (refer to table 3). COM4A – RS485 Not used. COM4B – RS-232 Microgateway.
- e. COM5 (J15) – Opto-coupled transmit/receive. VSD Adaptive Capacity Control Board or Style B Solid State Starter.

Each port is equipped with two LED's. A red TX LED illuminates as data is transmitted to or requested from another device. A green RX LED illuminates as data is received from another device. The RS-232 voltages are industry standard +5 to +25vdc and -5vdc to -25vdc logic levels. The RS-485 voltages are industry standard 0vdc and +1.5 to +5vdc logic levels. COM5 logic levels are 0vdc and +5vdc. A diagnostic test can be performed on each serial port to confirm proper operation. Refer to Diagnostics SECTION 23 of this manual.

The LED's and their functions are as follows:

- CR2 RX1 – COM1 serial port receive data.
- CR3 TX1 – COM1 serial port transmit data.
- CR12 TX4 – COM4 serial port transmit data.
- CR13 RX4 – COM4 serial port receive data.
- CR15 TX3 – COM3 serial port transmit data.
- CR14 RX3 – COM3 serial port receive data.
- CR11 RX2 – COM2 serial port receive data.

- CR16 TX2 – COM2 serial port transmit data.
- CR10 RX5 – COM5 serial port receive data.
- CR9 TX5 – COM5 serial port transmit data.

Display Interface

The graphic screens displayed on the liquid Crystal Display are created from the program downloaded from the Program Card and stored in the flash memory chip. The data to form these screens is output from J5. This data is in the form of red, green and blue drive signals applied to each of the 303,200 the display pixels arranged in a matrix of 640 columns x 480 rows. Each pixel consists of 3 windows; red, green and blue, through which a variable amount of light from the Display Backlight, is permitted to pass to the front of the display. The drive signals determine the amount of light permitted to pass through each window. The overall pixel color is a result of the gradient of red, green and blue light allowed to pass. The drive signal for each pixel is an 18 bit binary word; 6 for each of the 3 colors. The greater the binary value, the more light is permitted to pass. The pixels are driven sequentially from left to right, beginning with the top row. To coordinate the drive signals and assure the pixels in each row are driven from left to right and the columns are driven from top to bottom, the drive signals are accompanied by a clock and horizontal and vertical sync signals.

During the boot-up, the program in the BIOS eprom reads wire jumpers PID0 through PID3 on the Display Interface Board to determine the manufacturer of the display. Each display manufacturer requires a slightly different control. The program in the BIOS eprom configures the microboard for correct operation for the actual display installed.

Different display manufacturers require different supply and control voltages for their displays and backlights. Program Jumpers JP2 through JP5 and JP7 and JP8 must be configured to provide the required supply and control voltages to the display and backlight control. Table 3 lists the required program jumper configuration for each display. Also, a label attached to the display mounting plate lists the required program jumper configuration for that display. The position of program jumper JP2 determines whether the supply voltage is +5vdc or +3.3vdc.

The microboard controls the Display Backlight via J6. The Display Backlight is the light source for the display. The Backlight Inverter Board provides a high voltage AC power source for the lamp. It converts low voltage DC via J6-1 (+12vdc or +5Vdc, depending on position of Program Jumper JP5) to high voltage AC (500 to 1500Vac). This high voltage AC is applied to the lamp to cause it to illuminate. The Backlight is turned on and off with the “Backlight Enable” signal (J6-5). The position of Program Jumper JP4 determines whether this is a +12Vdc or +5vdc signal. In some displays, the backlight turns on when this signal transitions from low to high; others turn o when it transitions from high to low. The position of Program Jumper JP3 determines the transition that will occur when the Microboard outputs the Backlight Enable signal. JP3 must be positioned according to the display manufacturer’s requirement.

Under program control, the microboard controls the backlight brightness via the Lamp Dimmer circuit output at J6-7. In order to extend the life of the Backlight lamp, the brightness is driven to 50% after 10 minutes of Keypad inactivity. At this brightness level, the graphics are still visible. When Keypad activity is detected (a key is pressed), the lamp is driven back to full (100%) brightness. Some display manufacturers require a variable voltage to vary the brightness; others require a variable resistance. Program Jumpers JP7 and JP8 must be configured to enable the appropriate technique. The Lamp Dimmer is an integrated circuit that is the electrical equivalent of a 10K ohm potentiometer with 100 positions or steps (ref fig 10A). The Lamp Dimmer controls the position of the potentiometer. The lamp Dimmer varies the brightness of the backlight by applying a variable voltage (0-5.0vdc) or a variable resistance (0-10K ohms) to the Backlight Inverter Board. If Program Jumpers JP7 and JP8 are installed, the lamp Dimmer output is a variable voltage; if both are removed, the output is a variable resistance. The Lamp Dimmer outputs “Brightness Control Wiper” (J6-7) to the Backlight Inverter Board. If configured for variable voltage output, the voltage between J6-7 and J6-8 can be varied from 0Vdc (100% brightness) to 5.0Vdc (0% brightness). If configured for variable resistance, the resistance between J6-6 and J6-7 varies from 0 ohms (0% brightness) to 10K ohms (100% brightness).

Refer to Display SECTION 5, 6 and 7 of this manual for details of the display interface.

Remote Setpoints

Remote Leaving Chilled Liquid temperature and Current Limit setpoints can be input via the RS-232 Microgateway interface at J2 or directly to the Microboard at J22 (ref fig 12). The inputs at J22 are configured with Program Jumpers JP23 and JP24 to accept these inputs in either 0-10vdc, 2-10vdc 0-20Ma or 4-20Ma form. Refer to Table 3 for Program Jumper configurations and SECTION 18 of this manual for details of the Remote Setpoints.

POWER SUPPLY

The Microboard receives 3 supply voltages (Microboard J1) from the **Power Supply**; +12VDC, -12VDC, +5VDC and Ground. The -12VDC and +12VDC are used directly by various circuits. The +12VDC and +5VDC are input to **Voltage Regulators** to derive other regulated voltages. The +5VDC (fused by 5 Amp fuse F1 on rev “E” and later boards) is input to a +3.3VDC regulator. The output is a 3.3VDC regulated voltage. The +12VDC (fused by 5 Amp fuse F2 on rev “E” and later boards) is input to a 5VDC regulator. The output of this regulator powers only the Analog circuits. This includes the MUX, A/D converter, CM-2 module, Mod “A” Solid State Starter Logic Board, Transducers and Thermistors. As depicted on the Microboard figure, these voltages can be monitored at Test Posts TP1 through TP6.

SERVICE REPLACEMENT

Replacement part number 331-02430-601 is supplied as service replacement for microboard 031-01730-000. Refer to SECTION 3A of this manual. and Replacement Parts List 160.54-RP1. Replacement part 331-01730-601 (microboard 031-01730-000) is no longer available.

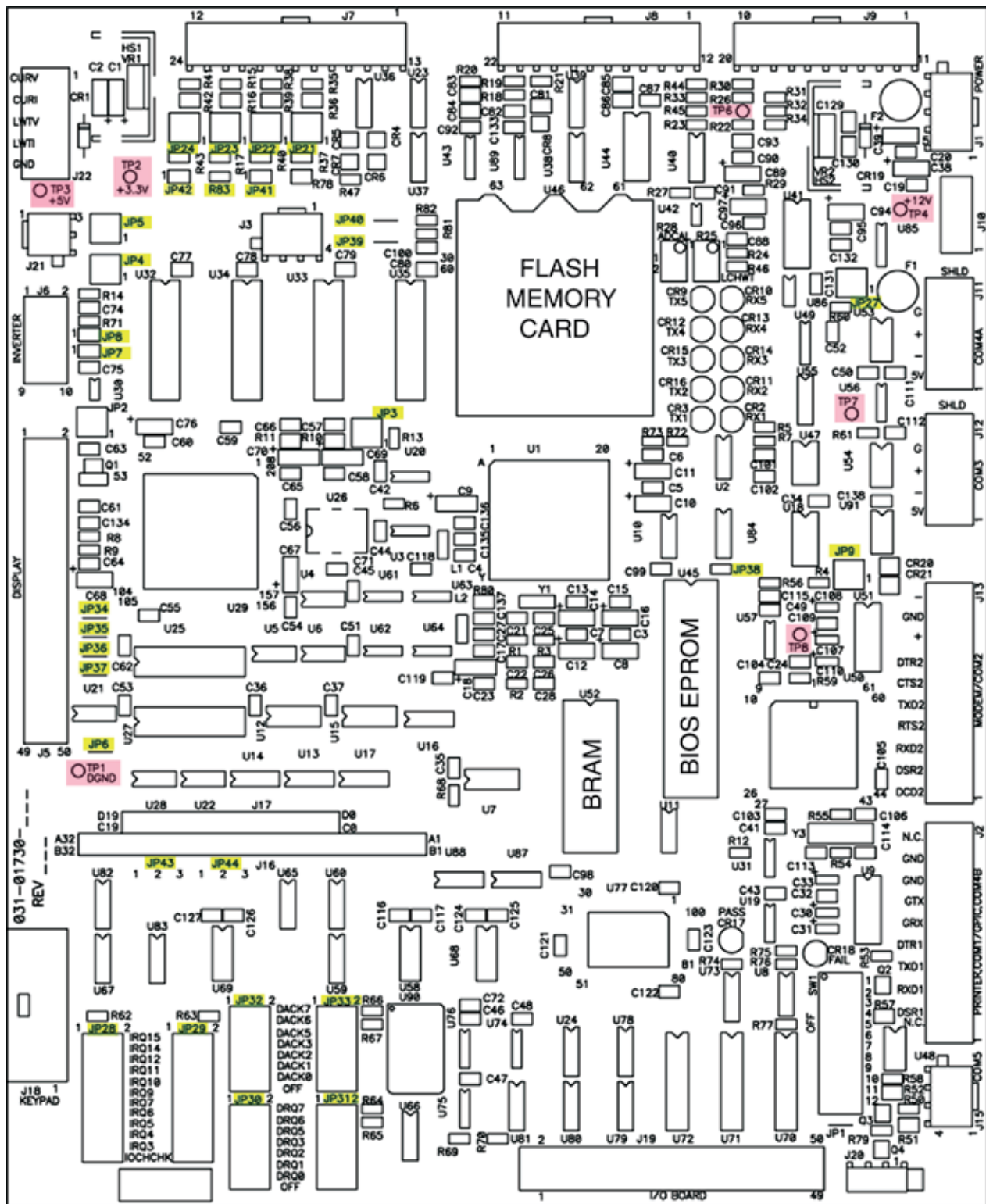

LD07776

FIG. 7 – MICROBOARD 031-01730-000

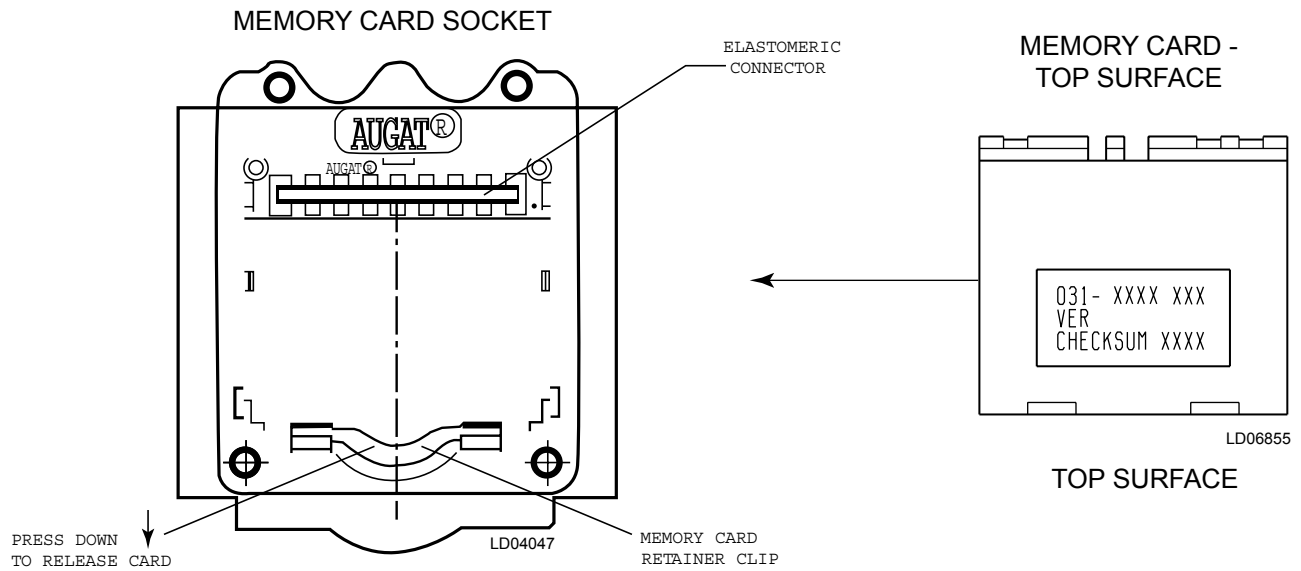

3

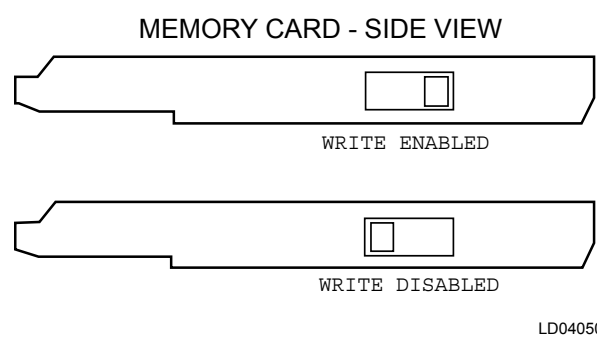
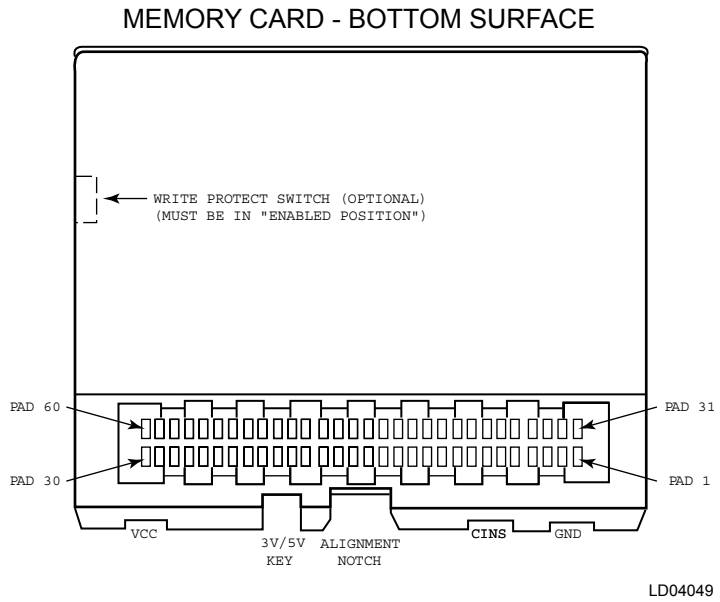
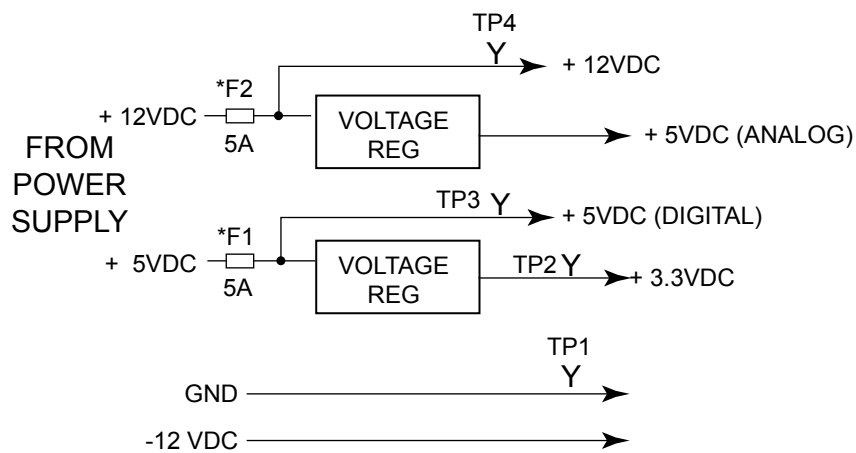

FIG. 8 – FLASH MEMORY CARD



*REV "E" and later boards only.

LD09564

FIG. 9 – MICROBOARD (031-01730-000) POWER SUPPLY TEST POINTS

TABLE 1

MICROBOARD 031-01730-000 PROGRAM JUMPERS

MICROBOARD PROGRAM JUMPERS

JP1 - Watchdog enable/disable. The position of this jumper, in conjunction with Program switch SW 1 position 12 enables or disables the program Watchdog protection.

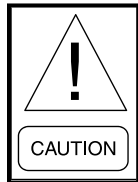

Never disable the watchdog protection. Severe compressor or chiller damage could result. The ability to disable the watchdog protection is provided for factory testing only!!!

IN - Watchdog protection enabled.

OUT - Permits Program switch SW1 position 12 to enable or disable the program

Watchdog protection as follows:

Position 12 **ON** - Watchdog protection enabled

OFF - Watchdog protection disabled

JP2 - Display power and logic levels. Determines the power supply voltage applied to the display.

Pins 1-2: +5VDC SHARP LQ10D367/368 and LQ10D421 displays.

Pins 2-3: +3.3VDC NEC NL6448ACCC33-24 and LG Semicon LP104V2-W displays.

JP3 - Display backlight enable signal level polarity. Jumper must be positioned according to the voltage level required to turn on the Display Backlight.

Pins 1-2: 0VDC SHARP LQ10D421 Display.

Pins 2-3: +12VDC or +5VDC as determined by position of JP4. SHARP LQ10D367/368, NEC NL6448AC33-24 and LG Semicon LP104V2-W displays.

JP4 - Display backlight enable signal logic levels. Determines the logic levels of the Backlight enable signal.

Pins 1-2: +12VDC/0VDC SHARP LQ10D421 display.

Pins 2-3: +5VDC/0VDC SHARPLQ10D367/368 NEC NL6448AC33-24 and LG Semicon LP104V2-W displays.

JP5 - Display backlight power. Determines the power supply voltage applied to the Display Backlight Inverter Board.

Pins 1-2: +12VDC. SHARP LQ10D367/368 and LQ10D421, NEC NL6448AC33-24 and LG Semicon LP104V2-W displays.

Pins 2-3: +5VDC. Not Used

JP6 - Display memory type. Jumper must be positioned according to type of RAM used for display memory devices (U25 & U27).

IN - EDO: (extended data out) type. Jumper should be IN.

OUT - FPM: (fast page mode) type. Not Used

JP7, JP8 - Display brightness control technique. Determines whether the display brightness is controlled by a variable voltage or variable resistance.

IN: Variable voltage (0-5.0VDC). SHARP LQ10D367, LQ10D421 and LG Semicon LP104V2-W displays.

OUT: Variable resistance. NEC NL6448AC33-24 display.

JP9 - JP20 - Not Used

JP21 - Factory mounted thermal-type flow sensor – evaporator. Style F and later chillers only (applies to Flash Memory Card version C.MLM.01.07.xxx and later).

OUT: Not Used.

Pins 1-2: Not Used.

Pins 2-3: Style F and later chillers with factory mounted evaporator thermal-type flow sensor.

JP22 - Factory mounted thermal-type flow sensor – condenser. Style F and later chillers only (Applies to Flash Memory Card version C.MLM.01.07.xxx and later).

OUT: Not Used.

Pins 1-2: Not Used.

Pins 2-3: Style F and later chillers with factory mounted condenser thermal-type flow sensor.

- JP23** - Remote Current Limit Setpoint (J22) type. Configures analog input for 0-10VDC, 2-10VDC, 0-20mA or 4-20mA.
OUT: Allows a 0-10VDC or 2-10VDC input on J22-1
Pins 1-2: Allows a 0-20mA or 4-20mA input on J22-2
Pins 2-3: Not Used
- JP24** - Remote Leaving Chilled Liquid Temp Setpoint (J22) type. Configures analog input for 0-10VDC, 2-10VDC, 0-20mA or 4-20mA.
OUT: Allows a 0-10VDC or 2-10VDC input on J22-3
Pins 1-2: Allows a 0-20mA or 4-20mA input on J22-4
Pins 2-3: Not Used
- JP25, JP26** - Not Used
- JP27** - COM 4 serial communications port. Configures COM 4 port to be either RS-485 for Multi-Unit Communications (COM 4A) or RS-232 for GPIC board (COM4B).
Pins 1-2: Enables port 4A. Allows an RS-485 connection to Microboard J11 for MultiUnit Communications.
Pins 2-3: Enables port 4B. Allows an RS-232 connection to Microboard J2 for MicroGateway communications.
- JP28** - PC-104 Port interrupt assignment. Assigns selected PC-104 interrupt request to PIRQ7 on the microprocessor. Interrupt request selections are silk screened on the Microboard adjacent to the program jumper. Not used on YK chiller applications.
- JP29** - PC-104 Port interrupt assignment. Assigns selected PC-104 interrupt request to PIRQ6 on the microprocessor. Interrupt request selections are silk screened on the Microboard adjacent to the program jumper. Future modem application.
- JP30** - PC-104 Port DMA assignment. Assigns selected PC-104 DMA request to PIRQ0 on the microprocessor. DMA request selections are silk screened on the Microboard adjacent to the program jumper. Not used on YK Chiller applications.
- JP31** - PC-104 Port DMA assignment. Assigns selected PC-104 DMA request to PIRQ1 on the microprocessor. DMA request selections are silk screened on the Microboard adjacent to the program jumper. Not used on YK Chiller applications.
- JP32** - PC-104 Port DMA acknowledge assignment. Assigns selected PC-104 DMA acknowledge to PDACK0 on the microprocessor. DMA acknowledge selections are silk screened on the Microboard adjacent to the program jumper. Not used on YK Chiller applications.
- JP33** - PC-104 Port DMA acknowledge assignment. Assigns selected PC-104 DMA acknowledge to PDACK1 on the microprocessor. DMA acknowledge selections are silk screened on the Microboard adjacent to the program jumper. Not used on YK Chiller applications.
- JP34** - Refrigerant type. Jumper must be positioned according to the refrigerant type installed in the chiller.
IN: R22
OUT: R134a
- JP35** - Water/Brine application. Jumper must be positioned according to whether the chiller is cooling water or a brine solution.
IN: Water. Leaving chilled liquid temperature setpoint range 38°F (36°F if Smart Freeze is enabled) to 70°F.
OUT: Brine. Leaving chilled liquid temperature setpoint range 10°F to 70°F.
- JP36** - Steam Turbine or Electric Motor drive - Determines the “Coastdown” duration (Oil Pump run duration after shutdown) and whether the “Motor Controller-Loss of Current” Program check is performed while the chiller is running.
IN: 150 seconds. Electric motor drive applications.
OUT: 15 minutes. Steam Turbine applications. “Motor controller-Loss of Current” check is not performed.

- JP37** - Compressor Motor starter type.
IN: Electro-Mechanical or Solid State Starter
OUT: Variable Speed Drive Program Jumper
 JP39 must be IN for this application.
- JP38** - BIOS EPROM U45 size. Jumper must be positioned according to size of U45. Jumper is a 10 Ohm resistor that is soldered to board. It is not a shunt jumper.
IN: 256K
OUT: 64K or 128K. Should be OUT for YK chiller applications.
- JP39** - Solid State Starter style.
Note: On Variable speed Drive applications, this jumper must be IN.
IN: Mod “A” - Old style with Logic Board mounted in OptiView Control Center.
OUT: Mod “B” - New style with integrated Logic/Trigger Board mounted Starter cabinet.
- JP40** - Not Used
- JP43, JP44** – Display Controller (U29) type (rev “E” and later boards only). Must be positioned according to the Display Controller type installed on Microboard. Configured at the time the board is manufactured and should not require field configuration.
Pins 1-2: Type 65548
Pins 2-3: Type 65550
- JP41, JP42** - High Speed Thrust Bearing Proximity Probe type (Not applicable to “P” compressors and style F and later chillers with “G, Q” and “H5-8” compressors). Refer to Section 13 to determine which Probe is present.
IN: Not Used
OUT: +24VDC Probe, part number 025-30961-000 or 025-35900-000.
- JP43, JP44** - Display Controller (U29) type (rev “E” and later boards only). Must be positioned according to the Display Controller type installed on Microboard. Configured at the time the board is manufactured and should not require field configuration.
Pins 1-2: Type 65548
Pins 2-3: Type 65550

TABLE 2

MICROBOARD 031-01730-000 PROGRAM SWITCHES

SW1

1 - Not Used

2 - Oil Pump style - Configures Program operation for either Variable Speed Drive oil pump or fixed speed oil pump. Chillers equipped with the variable speed oil pump have a program controlled oil heater and a different complement of solenoid valves than chillers equipped with a fixed speed oil pump.

ON: (Style D/E/F) Variable Speed Oil Pump - Configures the Program to operate the Oil Pump Variable Speed Drive, the oil heater and the following Solenoid Valves: Oil Return and Liquid Line (J compressors only) connected in parallel to TB 1-6 1.

OFF: (Style C) Fixed Speed Oil Pump - Configures the Program to operate the fixed speed Oil Pump and the following Solenoid Valves: TB1-34 Liquid Line, TB1-61 Oil Return and Vent Line connected in parallel, TB1-62 High Speed Thrust.

3 - Prerun - Determines the duration of the "System Prelube" period.

ON: Extended prerun. "System Prelube" period is 180 seconds in duration. Oil Pump runs for 167 seconds.

OFF: Standard prerun. "System Prelube" period is 50 seconds in duration. Oil Pump runs for 37 seconds.

4 - Diagnostics - Enables or disables software diagnostics.

ON: Enables software diagnostics. Disables normal chiller operation.

OFF: Disables software diagnostics. Enables normal chiller operation.

5 - Auto-restart - Determines the course of action required to restart the chiller, if a power failure occurs while the chiller is running.

ON: Chiller will automatically restart when power is restored.

OFF: Requires a manual reset after power is restored. The chiller will not start until the operator moves the keypad **START-RUN-STOP/RESET** rocker switch to the **STOP/RESET** position. If in **LOCAL** mode, the chiller can then be restarted by initiating a local start. If in **REMOTE** mode, the chiller will restart upon receipt of a remote start signal.

6 - Anti-recycle - Enables or disables the anti-recycle timer.



The anti-recycle timer must NEVER be disabled unless it is absolutely necessary to do so during troubleshooting.

ON: Enables anti-recycle timer. Solid State Starter and Electro-mechanical starter applications - Chiller cannot be started at intervals shorter than once every 30 minutes. VSD applications (JP37 Out) – Chiller can be started at the completion of **SYSTEM COASTDOWN** at intervals shorter than once every 10 minutes up to 5 times. On the 5th shutdown, a 10 minute timer is started and restart is inhibited until the timer has elapsed.

OFF: Disables anti-recycle timer. Chiller can be started at the completion of **SYSTEM COASTDOWN**, regardless of how long the chiller had been running.

7 - Compressor Motor Variable Speed Drive - Motor/Power Line frequency application.

ON: 50 Hz

OFF: 60 Hz

8 - Chilled Water Pump operation - Determines Chilled Water Pump control contacts (I/O Board TB2-44/45) operation when chiller shuts down on various **CYCLING** shutdowns.

ON: Enhanced operation. Contacts open at completion of **System Coastdown** after all shutdowns except when it shuts down on “**LEAVING CHILLED LIQUID - LOW TEMPERATURE**”, “**MULTIUNIT CYCLING - CONTACTS OPEN**” AND “**SYSTEM CYCLING - CONTACTS OPEN**”.

OFF: Standard operation. Contacts open at completion of **System Coastdown** after all shutdowns except when chiller shuts down on “**LEAVING CHILLED LIQUID - LOW TEMPERATURE**”. On Low Water temp shutdowns, they remain closed, causing the pump to continue to run while the chiller is shutdown.

9 - Not Used

10 - Not Used

11 - Not Used

12 - Watchdog Protection -Used in conjunction with Program Jumper JP1 (see above) to enable/disable the program watchdog protection. With JP1 **IN**, this switch setting has no effect. With JP1 **OUT**, this switch setting determines whether the watchdog protection is enabled or disabled.

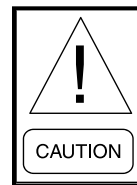

NEVER disable the watchdog protection! Severe compressor or chiller damage could result. The ability to disable the watchdog protection is provided for YORK factory testing only.

ON: Watchdog protection enabled.

OFF: Watchdog protection disabled.

3

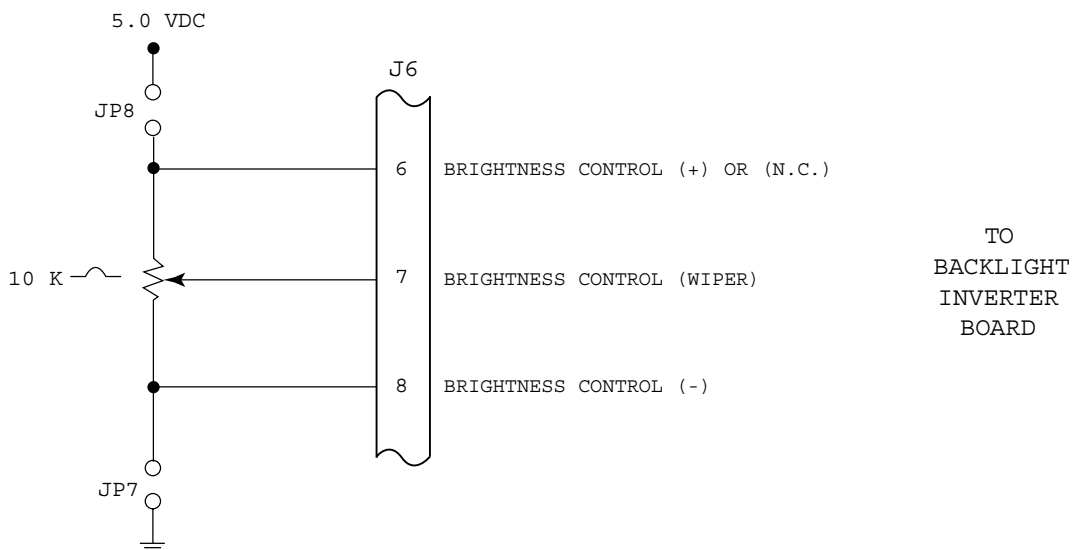

NOTES:

1. J6-6 not connected (N.C.) to Backlight Inverter Board when display is manufactured by Sharp or NEC.
2. The position of Program Jumpers JP7 & JP8 determine the output at J6-7; In = Variable Voltage; Out = Variable Resistance. Refer to Program Jumper Listing in Table 1 for applications.
3. Potentiometer is actually an integrated circuit that is the electrical equivalent of a 10K potentiometer.

LD04054

FIG. 10 – MICROBOARD LAMP DIMMER CIRCUIT

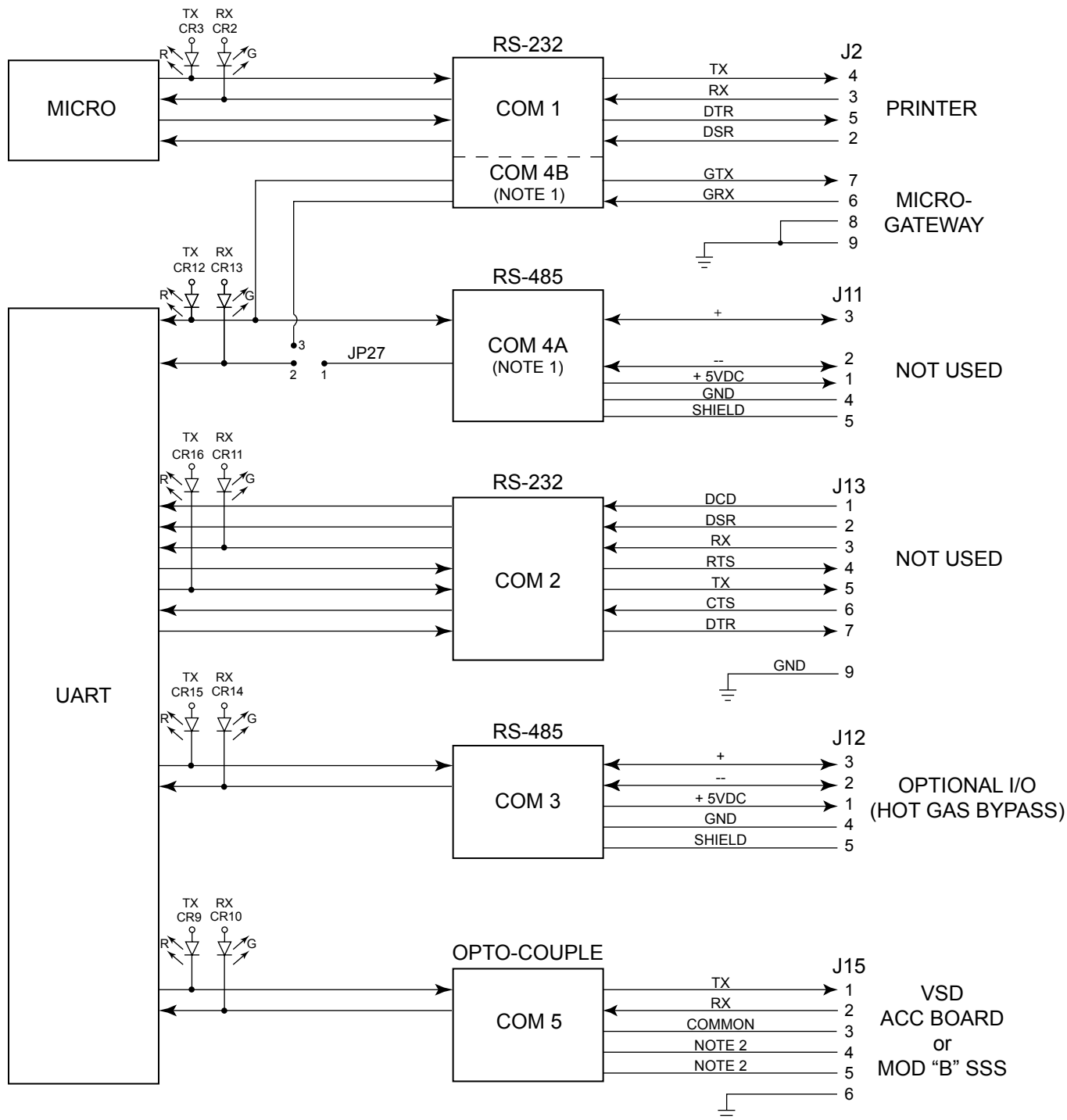

NOTES:

1. Microboard Program Jumper JP27 determines whether COM 4A or 4B can be used. 1 & 2 - 4A, 2 & 3, 4B. Refer to Table 1.
2. J15-4 Loop-Around Test IN. J15-5 Loop-Around Test OUT. Refer to FIG. 70 for details.

LD07778

FIG. 11 – MICROBOARD SERIAL DATA COMMUNICATIONS PORTS

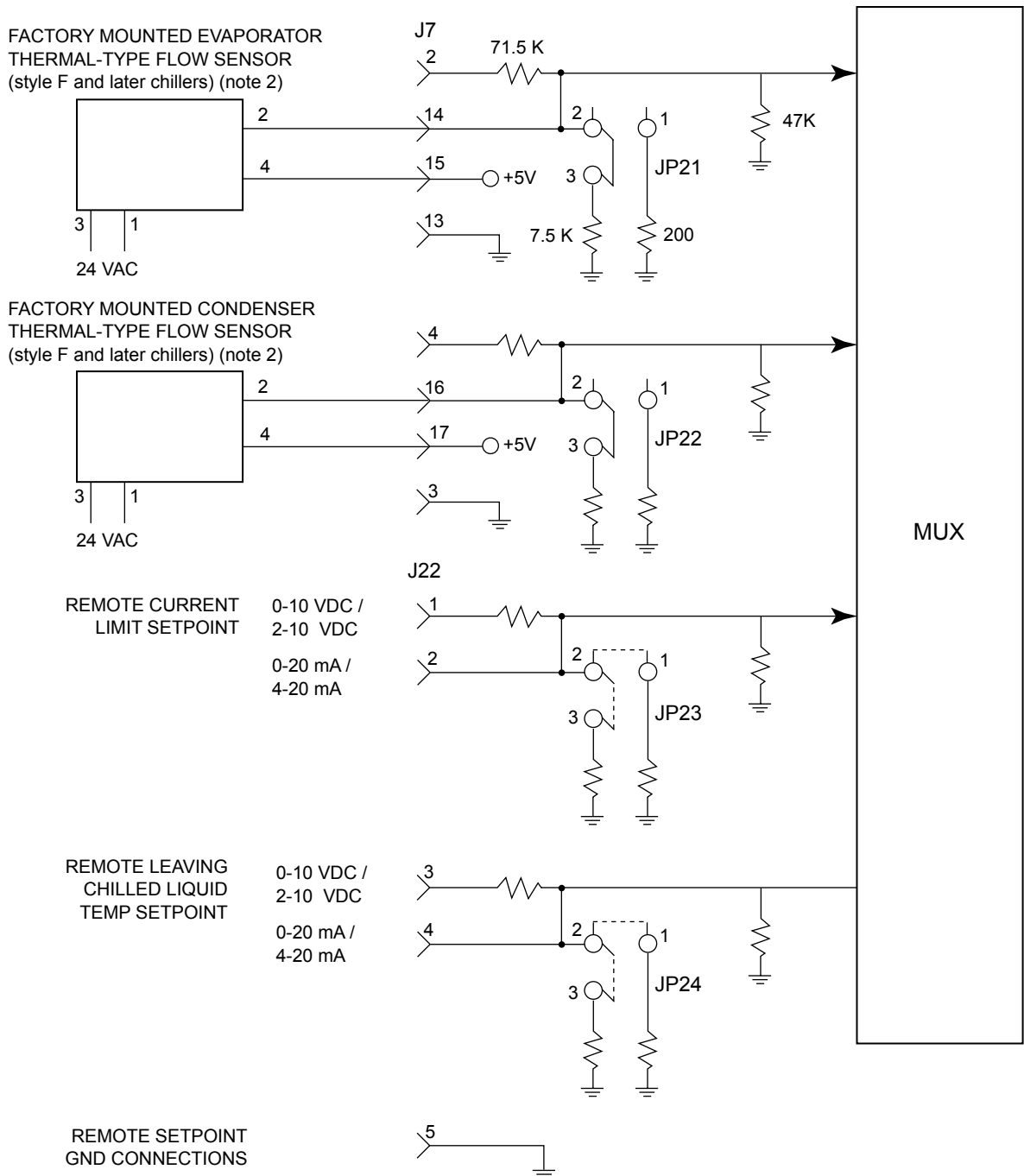

3

NOTE:

1. Program Jumpers JP23 – JP24 must be positioned on pins 1-2 or 3-4 according to input signal type. Refer to Table 1.
2. Applies to Flash Memory Card version C.MLM.01.07.xxx and later. Program Jumpers JP21 and JP22 must be on pins 2-3 on style F and later chillers equipped with factory-mounted thermal-type flow sensors.

FIG. 12 – CONFIGURABLE ANALOG & REMOTE SETPOINT INPUTS

SECTION 3A MICROBOARD

031-02430-000 and 031-02430-001

(REFER TO FIG. 5A-10A)

Microboard 031-02430-000 is supplied in new production chillers from January 2004 to June 2006 (ref FIG. 7A). Although this board uses a different microprocessor and supporting components, chiller control and operator interface are the same as the previous 031-01730-000 Microboard. It uses the same mounting hole pattern and has the same interface connectors as the previous board, making it backward compatible to all previous YK OptiView Control Centers equipped with the 031-01730-000 Microboard.

After June 2006, new production YK chillers will be supplied with microboard 03102430-001. This board is an upgraded version of the 031-02430-000 microboard. Its physical dimensions, mounting and connections are the same as the 031-02430-000 microboard. It is backward compatible to existing YK chillers using the 031-01730-000 or 031-02430-000 microboards and is supplied as service replacement for these boards in kit 331-02430-601. The upgrade includes a larger BRAM (U38) and an additional RS-485 port on COM2 serial port (J13) for Modbus serial communications protocol to Variable Speed Drives. The details of the differences between the -000 board and -001 board are described in the respective areas of this section. These upgrades are necessary for the following applications that require RS-485 Modbus communications to the microboard:

- Medium Voltage Solid State Starter (MV SSS) and Medium Voltage Variable Speed Drive (MV VSD).
- New production Variable Speed Drives (VSD) after March 2007. With the VSD Modbus applications, the Adaptive Capacity Control (ACC) functionality is contained in the microboard and the ACC Board is not used.
- New production Style B LCSSS after mid 2008.

The board is supplied with +12vdc (J1-3), -12vdc (J1-4), +5vdc (J1-1) and ground (J1-2) from the Power Supply (ref fig 9A). The -12vdc is not used. The +5vdc (fused by F1) can be monitored at TP3. It is applied to a +3.3vdc regulator, +2.5vdc regulator and used directly by the microboard circuits as the Vcc voltage. The outputs of these regulators are applied to microboard circuits and can be monitored at TP2 and TP5 respectively. The +12vdc (fused by F2) can be monitored at TP4. It is applied to a +5vdc regulator and used directly by microboard circuits. The output of the regulator is the +5vdc (analog) supply that powers all analog circuits and

is the source voltage for all transducers and thermistors. It can be monitored at TP10 as a 2.5vdc value created by 1K Ohm resistors voltage divider circuit as shown.

Test Points (Ref FIG. 9A)

The power supply voltages can be measured at following test points:

TP1 Gnd
 TP2 +3.3Vdc
 TP3 +5Vdc
 TP4 +12Vdc
 TP5 +2.5Vdc
 TP10 +2.5Vdc

Boot-up Program

The BIOS (Basic Input Output System) Eprom (U37) contains the boot-up program. The YORK part number is 031-02429-001 and is used in both the 031-02430-000 and 031-02430-001 microboards. It is available from the Baltimore Parts Distribution Center as a replacement part. The version is an alphanumeric code that identifies the application and the program revision level. The part number and version are printed on a label adhered to the surface of the Eprom. It is also displayed on the DIAGNOSTICS Screen in Service Access Level.

The version is as follows:

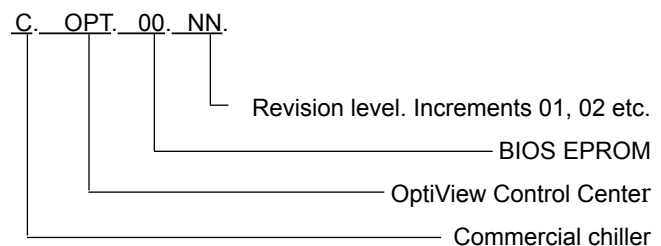

When power is first applied to the OptiView Control Center, a white screen is displayed while the boot-up is performed. During the boot-up, the program in the BIOS Eprom configures the microprocessor and related components and performs testing of certain components to assure those components are operational.

The sequence of events in the boot-up process are listed in the table below. The progress and pass/fail status of each step is displayed on the microboard 7-segment LED Display (U22). Due to the speed at which the boot-up proceeds, not all steps will be visible during the process. Not all pass/fail status is displayed on the white screen.

DIAGNOSTIC DISPLAY CODES

TEST	PASS CODE	FAIL ACTION	DISPLAY ON WHITE SCREEN
First init table complete	00	watchdog will cause reboot	No
SDRAM regs. Configured	01	watchdog will cause reboot	No
Switch to Protected Mode	02	watchdog will cause reboot	No
Jump to 32-bit code	03	watchdog will cause reboot	No
Low memory test start	04	watchdog will cause reboot	No
Low memory test complete	P1	"F1" on display and halt	No
Full memory test complete	P2	"F2" on display and halt	No
FPGA configuration	05	"P2" will remain on LED display	No
Display Cont. configured	06	"05" will remain on LED display	No
Flash Checksum Test	P3	"F3" will remain on LED display	Yes
BRAM test	P4	"F4" will remain on LED display	Yes
Flash Query Test	"passed"	"failed" and halt	Yes
Flash checksum	"passed"	"failed",halt & display code = F3	Yes
BRAM Test	"passed"	"failed" and halt	Yes

MISCELLANEOUS CODES

LED DISPLAY CODE	Description
FF	FPGA Configuration Failed, trying again
CH	Flash Checksum Test in progress
AP	Application setup in progress

CRITICAL CODES

LED DISPLAY CODE	Description
Ni	NMI handler invoked (should never occur)
[]	GPF has occurred (should never occur)

Chiller Operating Program

The Chiller Operating Program is a set of instructions to control the chiller. It contains the Safety and Cycling shutdown thresholds (non-changeable) and display screen messages and graphics.

The chiller operating program is stored in a non-removable Flash Memory chip (U35) that is soldered to the Microboard. New chillers are supplied programmed with the latest program available at the time of manufacture. The program version that is currently residing in the Microboard Flash Memory chip is displayed on the DIAGNOSTICS Screen in Service Access Level.

The on-board program can be upgraded by downloading the latest version from a Program Card using the procedure in the Service Replacement section of this book.

Program Card

The on-board program can be upgraded by downloading the latest program version from a Program Card. This is a 2 1/8 x 3 3/8 x 1/8 inch plastic card weighing 1.1oz (ref FIG. 8A). It is a portable memory storage device that is programmed with the chiller operating program. The Program Card part number for YK chillers is 031-02474-001 and is available from the Baltimore Parts Distribution Center (PDC). There is a Program Card for each chiller type (YT, YK, YS, YR, YD, etc) and each has a unique part number. A label affixed to the Program Card contains the part number and version. The version is an alpha-numeric code that identifies the chiller model applicability, language package, language package revision level and chiller operating program revision level.

The Program Card is applicable to both NEMA and CE applications. The Program Card for YK chillers has English, Simplified and Traditional Chinese, French, Portuguese, Spanish, Italian, German and Hungarian languages.

The program version that is currently residing in the Microboard Flash memory chip is displayed as the “Controls” Software Version on the DIAGNOSTICS Screen in Service Access Level.

The Program Card obtained from the PDC is programmed with the latest version of the chiller operating program. Program Cards can be reprogrammed.

A Program Card for a particular chiller type can be used to re-program other chillers of the same type. For example, it is not necessary to have more than one YK Program Card. A single YK card can be carried to different locations to re-program other YK OptiView Control Centers.

A Write Protect Switch on the edge of the Program Card prevents inadvertent writing to the Card during program downloading.

Handling precautions for the Program Card include:

- Do not allow dirt to enter connector
- Carry in protective sleeve
- Storage temperature range is -20 to 65°C (-4 to 149°F)

A label adhered to the Program Card contains the version and YORK part number. The version is an alphanumeric code that identifies the chiller model applicability, language package, language revision level and chiller control revision level. The version is as follows:

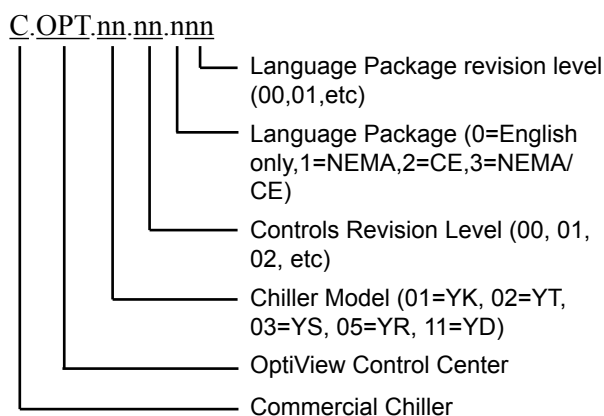

The Program card is inserted into connector U33 to download a program. Refer to instructions under Service Replacement below.

Program Download Connector U33

A Program Card is inserted into connector U33 to download a program. A protective cover prevents dirt from entering this connector. **IMPORTANT!** The protective cover must be in place at all times when not performing a program download. If dirt accumulates inside this connector, re-programming will not be successful.

Parallel Port Connector

Parallel port connector J4 is for future use. It is presently not supported.

BRAM (U38)

The BRAM (battery backed random access memory) memory device contains a battery that preserves the stored data during power failures. All of the programmed Setpoints, Sales Order Data, History Data, time of day and calendar data is stored here. The YORK Part number is printed on a label adhered to the surface of the BRAM. It is available from the Baltimore Parts Distribution Center as a replacement part.

The part number of the BRAM (U38) in the 031-02430-000 board is 031-02431-000 and its size is 32KB. It is installed in a 28-pin socket. Program Jumper JP14 is a non-removable (soldered) wire jumper that connects DC power to the appropriate pin on the BRAM for 32KB operation.

The part number of the BRAM (U52) in the 031-02430-001 board is 031-02565-000 and its size is 128KB. It is installed in a 32-pin socket. Program Jumper JP14 is a removable 2-pin shunt type jumper. The 128KB BRAM requires the shunt be NOT INSTALLED and the board is supplied in this configuration. If the shunt is installed on JP14, it would apply DC power to an incorrect pin on the 128KB BRAM and the board would not function. The 128KB BRAM is required for MV SSS, MV VSD, and those VSD that communicate with the microboard using Modbus serial communications protocol.

The 031-02430-001 board with 128KB BRAM requires software that has “BRAM size detect” capability. If it does not have this capability, the board will not function.

YK chiller software version C.OPT.01.15.xxx (and later) has this capability and is required.

When replacing a 031-02430-000 microboard with a 031-02430-001 microboard in applications other than MV SSS, MV VSD and VSD Modbus, the smaller BRAM from the 031-02430-000 board can be transferred to the 031-02430-001 microboard. See BRAM transfer exception in Microboard Service Replacement later in this section.

Watchdog Circuit

The Watchdog circuit performs two functions as follows:

- Power failure detection
- Program latch-up detection/prevention

The Watchdog circuit monitors the +5vdc from the power supply and the +3.3vdc from the onboard regulator to determine when a power failure is occurring. If the +5vdc decreases to the threshold of (+4.75vdc to 4.5vdc) or the +3.3vdc decreases to the threshold of (3.04 to 2.8vdc), a reset is issued to the microprocessor and the chiller shuts down. When power is restored, the white screen is displayed and the boot-up is performed as described above. When the graphic screen is displayed, the message “Control Panel – Power failure” is displayed.

The Watchdog Circuit also assures that the entire program is being executed and that the program has not latched-up, bypassing important safety checks. The Watchdog circuit is a timer that times-out if not given a reset pulse within its time-out period (1 - 2.25 seconds). To prevent a time-out, the microprocessor sends a reset pulse to the Watchdog circuit every time the complete program has been executed. Since it takes less than 1 second to perform the entire program, the Watchdog circuit doesn't time-out under normal operation. However, if the entire program is not executed or something prevents the microprocessor from sending the reset pulse as described below, the Watchdog circuit times-out and sends a reset to the microprocessor, initiating a re-boot. If running, the chiller shuts down. The display momentarily blanks and white screen is displayed while the boot-up program executes as described above. When the graphic screen is displayed, either of two messages is displayed depending on the type of Watchdog shutdown as explained below.

There are two different watchdog initiated shutdowns; a “hardware” watchdog initiated shutdown and a “software” watchdog initiated shutdown.

In the “hardware” watchdog initiated shutdown, a program problem, on-board noise or hardware problem could prevent the watchdog time-out. If this occurs, a re-boot is initiated and when the graphic screen is displayed, “Control Panel – Power Failure” is displayed.

In the “software” watchdog initiated shutdown, the program intentionally initiates the reboot because it has detected program interruption. After the re-boot, “Watchdog – Software Reboot” is displayed on the graphic screen.

Program Jumpers/Program Switches

The Program Jumpers (Table 3) and Program Switches (Table 4) are used to alter the program operation or configure the Microboard hardware for specific operation. This allows the Program and Microboard to be universal for all standard applications. Refer to Table 3 and 4 for the function of each jumper and switch. The position of some jumpers can be determined by the Service Technician to meet the desired operation. Others must be positioned according to the requirements of the size, type or style of components and thus are determined by the YORK factory. The jumpers are plastic sleeves with metal inserts that are inserted over 2-prong or 3-prong conductors. The Program Switches are miniature switches that are placed in either the ON or OFF position.

Keypad Interface

The Keypad is read via J18. The Keypad is a matrix of conductors arranged in rows and columns (ref FIG. 32 and 33). There are 4 rows and 8 columns. When a key is pressed, the conductors are pressed together at that point, creating continuity between the row conductor and the column conductor. The keypad is read by applying a logic low to a row while leaving +5vdc pullup on all other rows. The micro then reads the 8 columns. If any column has a logic low on it, the key corresponding to that coordinate (row, column) is being pressed. The micro reads the entire keypad by repeating this routine beginning with row 1 and ending with row 4. The entire keypad is continually read while the control center is powered. Refer to SECTION 8 of this manual for details of the Keypad.

CM-2 Board or Style A Solid State Starter Interface

The microboard retrieves certain operating parameters (via J10) from the compressor motor starter control board (CM-2 Current Board for Electromechanical starter or Style “A” Solid State Starter Logic Board). Refer to the appropriate section of this book for detailed explanation of each board. Both boards contain an 8 channel multiplexer. The micro sequentially and continually reads channels 0 through 7. It reads each channel by applying a 3-bit binary address to the multiplexer. A 0-5vdc analog value is returned from each channel. The function of each is in the table below. The micro determines which board, and therefore which starter is present, by the value returned from channel 0. Since channels 0 through 6 are grounded, the CM-2 board returns a 0vdc value. The Solid State Starter Logic Board returns a value >0.41vdc to +5vdc. If the value is <0.4vdc, it indicates the starter is an Electro-mechanical (EM) starter and the micro then reads channel 7 to retrieve the peak motor current value. A value >0.4vdc indicates the starter is an “A” style Solid State Starter and the micro reads channels 1 through 7. In the Solid State Starter, channel 0 indicates the starter size (model) and voltmeter range (300Vac or 600Vac). Channel 1 is a hardware generated 100% FLA (prevents pre-rotation vanes from further opening) or 104% FLA (closes pre-rotation vanes until motor current is <102%) current limit override command that overrides normal Pro-rotation Vanes control. Channels 2 through 4 are analog voltages that represent phase A, B and C motor current. The highest phase is Channels 5 through 7 are analog voltages that represent phase A, B and C Line Voltage. The data for each channel is shown on the following table:

Style B Solid State Starter Interface

Prior to June 2006, new production starters communicate with microboard 031-02430-000 via the Opto-coupled COM5 serial data port (J15) using YORK proprietary protocol. The serial data is represented by +5vdc and 0Vdc logic levels. J15-1 is TX data to the starter. J15-2 is RX data from the starter. Between June 2006 and mid 2008, new production chillers communicate with microboard 031-02430-001 using the same protocol.

After mid 2008, new production Starters communicate with microboard 031-02430-001 via COM 2 serial port (J13) using RS-485 Modbus protocol (requires software version C.OPT.01.18.307 or later). COM 2 serial port is selectable between RS-232 and RS-485 with Program Jumper JP17. It must be positioned on pins 1 & 2 to select RS-485 serial port operation. To allow microboard 031-02430-001 to be used as service replacement for 031-01730-000 or 031-02430-000 boards non-modbus applications in the field, the COM 5 serial port is retained on the 031-02430-001 board.

With microboard 031-02430-001 and software version C.OPT.01.18.307 (or later), when “SSS-Mod B” is selected as the motor drive type on the SETUP screen, additional setpoints must be entered on this screen. The appropriate serial port (COM 2-Modbus or COM 5 YORK) must be enabled using the “Motor Communications protocol” Setpoint. The selections are “Modbus” or “YORK”. When Modbus is selected, the “Motor Node ID” setpoint must be set to match the setting of the starter Logic/Trigger Board Modbus Address Switch SW1. They must be both be set to “1”.

Refer to FIG. 11A and Section 11 for details of the solid state starter interface.

MULTIPLEXER CHANNELS

	0	1	2	3	4	5	6	7
CM-2	Gnd	Gnd	Gnd	Gnd	Gnd	Gnd	Gnd	Peak Motor Current (%FLA)
Style A Solid State Starter	Starter model/ voltmeter range	Current limit command	Phase C motor current	Phase B motor current	Phase A motor current	Phase A line voltage	Phase B line voltage	Phase C line voltage

Variable Speed Drive Interface

Prior to June 2006, new production Variable Speed Drives communicate with microboard 031-02430-000 via the Opto-coupled COM5 serial data port (J15) using a YORK proprietary protocol. The serial data is represented by +5vdc and 0Vdc logic levels. J15-1 is TX data to the starter. J15-2 is RX data from the starter. Between June 2006 and March 2007, new production VSD communicate with microboard 031-02430-001 using the same interface/protocol.

After March 2007, new production Variable Speed Drives communicate with microboard 031-02430-001 via COM2 serial data port (J13) using RS-485 Modbus protocol. Software version C.OPT.01.16.xxx (or later) is required for COM2 Modbus operation. COM2 serial port is selectable between RS-232 and RS-485 with Program Jumper JP17. It must be positioned on pins 1 & 2 to select RS-485 serial port operation. With the VSD Modbus applications, the Adaptive Capacity Control (ACC) functionality is contained in the microboard and the ACC Board is not used.

To allow microboard 031-02430-001 to be used as service replacement for 031-01730-000 or 031-02430-000 boards non-Modbus applications already in the field, the COM5 serial port is retained on the 031-02430-001 board.

With microboard 031-02430-001 and software version C.OPT.01.16.xxx (or later), when “VSD-60Hz” or “VSD-50Hz” is selected on the SETUP Screen, additional Setpoints must be entered on this Screen: The appropriate serial port (COM2-Modbus or COM5-YORK) must be enabled using the “Motor Communications Protocol” Setpoint. The selections are “Modbus or “York”. When Modbus is selected, the “Motor Node ID” setpoint must be set to match the setting of the VSD Logic Board Modbus Address Switch SW3. They must be both set to “1”.

Refer to FIG. 11A and Section 12 for details of the variable speed drive interface.

Medium Voltage Solid State Starter (MV SSS) and Medium Voltage Variable Speed Drive Interface (MV VSD)

These drives communicate with the Microboard via the COM2 RS-485 Modbus serial port (J13). COM2 serial port is selectable between RS-232 and RS-485 with

Program Jumper JP17. It must be positioned on pins 1 & 2 to select RS-485 serial port operation. Refer to FIG. 11A and YORK Operation and Service manuals 160.00-M5 (MV SSS) and 160.00- M6 (MV VSD) for details of this interface. Microboard 031-02430-001 is required for these applications. Software version C.OPT.01.15.xxx (or later) is required for MV SSS. Software version C.OPT.01.16.xxx (or later) is required for MV VSD. When the MV SSS or MV VSD is selected on the SETUP Screen, the COM2 serial port with Modbus protocol is automatically enabled. With the MV VSD, the Adaptive capacity Control functionality is contained on the microboard.

Printer Interface

An optional Printer can be connected to COM1 RS-232 serial data port (J2). J2-4 is TX data to the printer. J2-2 is the DSR (Data Set Ready or busy) signal from the printer. Signal levels are standard RS-232. The microboard sends data to the printer at the selected baud rate until the printer buffer becomes full, whereupon the printer asserts its Busy signal. The microboard suspends data transmission until the printer can accept more data. Each printer must be setup/configured to operate properly with the microboard. The Baud, Data Bits, Parity and Stop Bits must be programmed on the Comms Screen. Other printer setup is performed on the PRINTER Screen. Refer to YORK manual 160.54-O1 for details of available printers and printer setup instructions.

MicroGateway Interface

An optional Microgateway printed circuit board can be connected to the COM 4B RS-232 serial data port (J2). J2-7 is TX data to the MicroGateway. J2-6 is RX data from the Microgateway. Signal levels are standard RS-232. The MicroGateway polls system pressures, temperatures and status from the microboard. It holds it for retrieval by third-party devices. Refer to SECTION 15 of this manual.

Digital Inputs

The I/O Board converts the 115Vac inputs to logic level inputs for the microboard at J19. A 115Vac input to the I/O board is converted to a logic low (<1Vdc). A 0Vac input to the I/O Board is converted to a logic high (>4Vdc). Refer to SECTION 4 of this manual for details of the I/O Board.

Digital Outputs

The microboard controls 115vac relays and solenoids via the I/O Board (via J19). The I/O Board contains +12Vdc relays that isolate the microboard low voltage circuits from the 115Vac device coils. Solid state switching devices are used to control the relays. The microboard energizes the +12Vdc relays by applying a ground to the coil input. They are de-energized by opening the ground path. The contacts of these relays switch 115Vac to system relays and solenoids. The outputs that control the chilled liquid pump and compressor motor starter have anti-chatter (anti-recycle) timers associated with them. The output that controls relay K0 is not allowed to change at a rate greater than once every 10 seconds. The output that controls relay K13 is not allowed to change at a rate greater than once every 20 seconds.

The microboard controls Actuator motors via Triacs on the I/O Board. Each actuator has an open winding and a close winding. Current flowing through a winding causes the actuator to rotate in the respective direction. Each winding is controlled by a Triac. The Triac is turned on to allow current to flow through a winding. The microboard turns on the Triac by applying a logic low (<1Vdc) to the Triac driver on the I/O Board. It turns it off by applying a logic high (>4vdc). Refer to SECTION 4 of this manual for details of the I/O Board.

Analog Inputs

System pressures, in the form of analog DC voltages, are input from Pressure Transducers. Refer to SECTION 16 of this manual. Formulas and graphs are included to calculate the expected transducer output voltage for a given pressure input.

System temperatures, in the form of analog DC voltages, are input from Thermistors. Refer to SECTION 17 of this manual. Included are tables to convert the expected output voltage for any temperature applied to the thermistor.

Style F (and later) chillers are supplied with factory-mounted Flow Sensors on the evaporator and condenser. These are electronic thermal-type sensors. The operating principle of the sensor is thermal conductivity. It uses the cooling effect of a flowing liquid to sense flow. The temperature of the heated sensor tip is sensed by a thermistor located in the tip. A second thermistor, located higher in the tip in a non-heated area, is only affected by changes in liquid temperature. The temperatures sensed by the thermistors are compared. Flowing liquid carries heat away from the heated sensor tip, lowering its

temperature. The higher the flow rate, the lower the tip temperature and therefore a lower differential between thermistors. Lower flow rates remove less heat from the tip allowing a higher tip temperature. The lower the flow, the greater the differential between thermistors. The sensor is vendor-calibrated to turn on its output at a flow rate of 20cm(0.6 ft.)/second. This is the setpoint. There are 11 LED's on the sensor that reflect the measured flow rate. The center located amber LED illuminates at the setpoint flow rate (and above). The 4 LED's to the left of the amber reflect flow rates below the setpoint. The 6 LED's to the right of the amber reflect flow rates above the setpoint. As the flow rate decreases from the setpoint, the LED display moves to the left. As the flow rate increases above the setpoint, the LED display moves to the right. The sensor operates from a 24Vac power source and has a solid state relay output. On each sensor, one side of the solid state relay (pin 4) is connected to +5vdc on the Microboard and the other side (pin 2) is connected to an analog input of the Microboard (refer to fig 12A and 12B). After power is applied, there is a thermal warm-up period of up to 20 seconds. During this time, the output could be unstable. When the setpoint (or greater) flow rate is sensed, the solid state relay output is turned on causing it to conduct current through the 7.5K ohm microboard load resistor to the +5vdc. This applies >+4Vdc to the microboard input. When a flow rate less than the setpoint is sensed, the solid state relay output is turned off, resulting in no conduction through the load resistor. This applies <1Vdc to the microboard input. To determine the state of the solid state relay, first confirm that +5vdc is present at pin 2 of the flow sensor. Then connect a voltmeter between the Microboard TP1 (Gnd) and the respective flow sensor input to the Microboard. The software accommodates either the Paddle type sensors connected to the TB4 of the I/O Board or the Thermal type sensors connected to either J7 or J14 on the Microboard. The actual connection point of the Thermal type sensors to the Microboard is determined by the chiller vintage (refer to fig 12A & 12B). On new production chillers prior to June 2009, they are provided connected to the Microboard J7. On new production chillers after June 2009, they are provided connected to the Microboard J14. To assure the program reads the correct input, the FLOW SWITCH setpoint on the OPERATIONS Screen must be set appropriately as explained in SECTION 23.

Serial Data Ports

Microboard 031-02430-000 is equipped with 6 serial data ports. Microboard 031-02430-001 is equipped with 7 serial ports. Refer to FIG. 11A. Each port is dedicated for a specific function as follows:

- a. COM1 (J2) – RS-232. Printer
- b. COM2 (J13) – RS-232 on Microboard 031-02430-000. RS-232 or RS-485, as selected with Program Jumper JP17 on Microboard 031-02430-001. The RS-485 port is used for Modbus communications to the Liquid Cooled Solid State Starter, Medium Voltage Solid State Starter, Medium Voltage Variable Speed Drive and Variable Speed Drives. The RS-232 port is not used.
- c. COM3 (J12) – RS-485. Hot Gas Bypass
- d. COM4 (4A-J11), (4B-J2) – This port is actually two ports. However, they cannot be used simultaneously. The position of program jumper JP27 determines which port can be used. (Refer to table 3). COM4A – RS485 not used. COM4B – RS-232 Microgateway.
- e. COM5 (J15) – Opto-coupled transmit/receive. VSD Adaptive Capacity Control Board or Style B Solid State Starter.

Each port is equipped with two LED's. A red TX LED illuminates as data is transmitted to or requested from another device. A green RX LED illuminates as data is received from another device. The RS-232 voltages are industry standard +5 to +25vdc and -5vdc to -25vdc logic levels. The RS-485 voltages are industry standard 0vdc and +1.5 to +5vdc logic levels. COM5 logic levels are 0vdc and +5vdc. A diagnostic test can be performed on each serial port to confirm proper operation. Refer to Diagnostics SECTION 23 of this manual.

The LED's and their functions are as follows:

- CR2 RX6 – Not used. Future COM6 serial port receive data.
- CR3 TX6 – Not used. Future COM6 serial port transmit data.
- CR4 RX1 – COM1 serial port receive data.
- CR5 TX1 – COM1 serial port transmit data.
- CR13 TX4 – COM4 serial port transmit data.
- CR14 RX4 – COM4 serial port receive data.
- CR15 TX3 – COM3 serial port transmit data.
- CR16 RX3 – COM3 serial port receive data.
- CR17 RX2 – COM2 serial port receive data.
- CR18 TX2 – COM2 serial port transmit data.
- CR19 RX5 – COM5 serial port receive data.
- CR20 TX5 – COM5 serial port transmit data.

Display Interface

The graphic screens displayed on the liquid Crystal Display are created from the program downloaded from the Program Card and stored in the flash memory chip. The data to form these screens is output from J5. This data is in the form of red, green and blue drive signals applied to each of the 303,200 the display pixels arranged in a matrix of 640 columns x 480 rows. Each pixel consists of 3 windows; red, green and blue, through which a variable amount of light from the Display Backlight, is permitted to pass to the front of the display. The drive signals determine the amount of light permitted to pass through each window. The overall pixel color is a result of the gradient of red, green and blue light allowed to pass. The drive signal for each pixel is an 18 bit binary word; 6 for each of the 3 colors. The greater the binary value, the more light is permitted to pass. The pixels are driven sequentially from left to right, beginning with the top row. To coordinate the drive signals and assure the pixels in each row are driven from left to right and the columns are driven from top to bottom, the drive signals are accompanied by a clock and horizontal and vertical sync signals.

During the boot-up, the program in the BIOS eprom reads wire jumpers PID0 through PID3 on the Display Interface Board to determine the manufacturer of the display. Each display manufacturer requires a slightly different control. The program in the BIOS eprom configures the microboard for correct operation for the actual display installed.

Different display manufacturers require different supply and control voltages for their displays and backlights. Program Jumpers JP2 through JP5 and JP7 and JP8 must be configured to provide the required supply and control voltages to the display and backlight control. Table 3 lists the required program jumper configuration for each display. Also, a label attached to the display mounting plate lists the required program jumper configuration for that display. The position of program jumper JP2 determines whether the supply voltage is +5vdc or +3.3vdc.

The microboard controls the Display Backlight via J6. The Display Backlight is the light source for the display. The Backlight Inverter Board provides a high voltage AC power source for the lamp. It converts low voltage DC via J6-1 (+12vdc or +5Vdc, depending on position of Program Jumper JP5) to high voltage AC (500 to 1500Vac). This high voltage AC is applied to the lamp to cause it to illuminate. The Backlight is turned on and off with the "Backlight Enable" signal (J6-5). The

position of Program Jumper JP4 determines whether this is a +12Vdc or +5vdc signal. In some displays, the backlight turns on when this signal transitions from low to high; others turn on when it transitions from high to low. The position of Program Jumper JP3 determines the transition that will occur when the Microboard outputs the Backlight Enable signal. JP3 must be positioned according to the display manufacturer's requirement.

Under program control, the microboard controls the backlight brightness via the Lamp Dimmer circuit output at J6-7. In order to extend the life of the Backlight lamp, the brightness is driven to 50% after 10 minutes of Keypad inactivity. At this brightness level, the graphics are still visible. When Keypad activity is detected (a key is pressed), the lamp is driven back to full (100%) brightness. Some display manufacturers require a variable voltage to vary the brightness; others require a variable resistance. Program Jumpers JP7 and JP8 must be configured to enable the appropriate technique. The Lamp Dimmer is an integrated circuit that is the electrical equivalent of a 10K ohm potentiometer with 100 positions or steps (ref FIG. 10A). The Lamp Dimmer controls the position of the potentiometer. The lamp Dimmer varies the brightness of the backlight by applying a variable voltage (0-5.0vdc) or a variable resistance (0-10K ohms) to the Backlight Inverter Board. If Program Jumpers JP7 and JP8 are installed, the lamp Dimmer output is a variable voltage; if both are removed, the output is a variable resistance. The Lamp Dimmer outputs "Brightness Control Wiper" (J6-7) to the Backlight Inverter Board. If configured for variable voltage output, the voltage between J6-7 and J6-8 can be varied from 0Vdc (100% brightness) to 5.0Vdc (0% brightness). If configured for variable resistance, the resistance between J6-6 and J6-7 varies from 0 ohms (0% brightness) to 10K ohms (100% brightness).

Refer to Display SECTION 5, 6 and 7 of this manual for details of the display interface.

Remote Setpoints

Remote Leaving Chilled Liquid temperature and Current Limit setpoints can be input via the RS-232 Microgateway interface at J2 or directly to the Microboard at J22 (ref FIG. 12A). The inputs at J22 are configured with Program Jumpers JP23 and JP24 to accept these inputs in either 0-10vdc, 2-10vdc 0-20Ma or 4-20Ma form. Refer to Table 3 for Program Jumper configurations and SECTION 18 of this manual for details of the Remote Setpoints.

Configuration/Setup

The following functions are entered as setpoints on the SETUP Screen. Refer to entry instructions in SECTION 23 of this manual.

- Chilled Liquid Pump Operation – Determines Chilled Liquid Pump control contacts (I/O Board TB2-44/45) operation when chiller shuts down on cycling shutdowns. Selections are:
 1. Standard – Contacts open at completion of "System Coastdown" after all shutdowns except "Leaving Chilled Liquid – Low Temperature". On this shutdown, they remain closed, causing the pump to continue to run while the chiller is shutdown.
 2. Enhanced – Contacts open at completion of "System Coastdown" after all shutdowns except "Leaving Chilled Liquid – Low Temperature, Multi-Unit Cycling- Contacts Open" and "System Cycling – Contacts Open". On these shutdowns, they remain closed, causing the pumps to continue to run while the chiller is shutdown.
- Motor Drive Type – Configures the program for the applicable compressor motor drive type. Selections are:
 1. EM – Electromechanical Starter
 2. SSS-Mod A – Style A Solid State Starter
 3. SSS-Mod B – Style B Solid State Starter
 4. VSD-60Hz – Variable Speed Drive, 60Hz
 5. VSD-50Hz – Variable Speed Drive, 50Hz
 6. MV VSD – 60Hz (microboard 031-02430-001 with software version C.OPT.01.16.xxx (or later)
 7. MV VSD – 50Hz (microboard 031-02430-001 with software version C.OPT.01.16.xxx (or later)
 8. MV SSS (microboard 031-02430-001 with software version C.OPT.01.15.xxx (or later)
- Anti-recycle – Enables or Disables the Anti-recycle timer. CAUTION! The Anti-recycle timer must never be disabled unless advised by YORK factory. Selections are:
 1. Enabled – Enables the anti-recycle timer. Solid state Starters and electromechanical starter applications cannot be started at intervals shorter than once every 30 minutes. VSD applications can be started at the completion of "System Coastdown" up to 5 times. On the 5th shutdown, a 10-minute timer is started and restart is inhibited until the timer has elapsed.
 2. Disabled – Disables the anti-recycle timer. Chiller can be started at the completion of "System

Coastdown”, regardless of how long the chiller had been running.

- Power Failure Restart – Determines the course of action required to restart the chiller, if a power failure occurs while the chiller is running. Selections are:
 1. Manual – Requires a manual reset after power is restored. The chiller cannot be started until the operator moves the keypad Start-Run-Stop/Reset rocker switch to the stop/reset position.
 2. Auto – Chiller will automatically restart when power is restored.
- Coastdown – Determines the “Coastdown” duration (oil pump run duration after shutdown) and whether the “Motor Controller – Loss of Current” check and anti-recycle function is performed while the chiller is running. Selections are:
 1. Standard – Electric motor applications. With software version C.OPT.01.14.306 (and earlier), when STANDARD is selected, the coastdown duration is 150 seconds. With software version C.OPT.01.16.307 (and later), when STANDARD is selected, the COASTDOWN TIME setpoint appears (see below). This setpoint is used to set the duration over the range of 240 (default) to 900 seconds or 150 (default) to 900 seconds as determined by the selection made for the CHILLER STYLE/COMPRESSOR setpoint (on the Operations Screen).
 2. Enhanced – “Coastdown” is 15 minutes in duration. Steam Turbine applications. “Motor Controller - Loss of Current” check and anti-recycle function is not performed since there is no motor current.
- Pre-run – Determines the duration of the “System Pre-lube” period. Selections are:
 1. Standard – “System Prelube” is 50 seconds in duration.
 2. Extended – “System Prelube” is 180 seconds in duration.
- Oil Pump Package – Configures the program for either Variable Speed Drive Oil Pump or Fixed Speed Oil Pump. Chillers equipped with the Variable Speed Drive Oil Pump have a program controlled oil heater and a different complement of solenoid valves than chillers equipped with a fixed speed oil pump.
 1. Variable Speed (style D and later) – configures the program to operate the Variable Speed Drive Oil Pump, the oil heater (maintains oil temperature 50°F

above condenser saturation temperature) and the following solenoid valves: Oil Return and Liquid Line (J compressors only) connected in parallel to TB1-61.

2. Fixed Speed (style C) – Configures the program to operate the fixed speed Oil Pump and the following solenoid valves: TB1-34 Liquid Line, TB1-61 Oil Return and Vent Line connected in parallel, TB1-62 High Speed Thrust.

- Motor Communications Protocol
(VSD applications – Software version C.OPT.01.16.307 or later)
(Style B Liquid Cooled Solid State Starter applications – Software version C.OPT.01.18.307 or later)

Only displayed when MOTOR DRIVE TYPE setpoint above is selected as “VSD-60Hz”, “VSD-50Hz” or “SSS-Mod B”. Allows the Service Technician to enable the appropriate serial communications port for communications with the Style B Liquid Cooled Solid State Starter (LCSSS) or Variable Speed Drive (VSD). Early vintage Style B LCSSS and VSD communicate with the microboard using YORK protocol (COM 5 (J15)). Later vintage units use MODBUS protocol (COM 2 (J13)).

The protocol selection enables the appropriate communications port: YORK enables COM 5 (J15); MODBUS enables COM 2 (J13). Selection required is based on the hardware and interface that is present. Refer to SECTION 11 (LCSSS) or SECTION 12 (VSD) to determine which hardware/interface is present. The chiller must be stopped with the Start-Run-Stop/Reset switch in the Stop/Reset position to change this setpoint.

1. YORK - Enables COM 5 (J15) serial port. On Variable Speed Drive applications, used when the microboard is interfaced to the VSD via the ACC Board. On Style B Liquid Cooled Solid State Starter applications, used when the microboard is interfaced to the LCSSS Logic/Trigger Board TB2.
2. MODBUS - Enables COM 2 (J13) serial port. Microboard 031-02430-001 is required. Program Jumpers JP14 (BRAM size) and JP17 (COM 2 Serial Mode) must be configured per SECTION 3A, Table 3. VSD applications: Used when the ACC Board is not present and the microboard is interfaced directly

to VSD Logic Board 031-02506 (J16). Microboard must be equipped with 128K BRAM (031-02565-000). Style B Solid State Starter applications: Used when the microboard is interfaced to the LCSSS Logic/Trigger Board 031-02505 (J14). Microboard can be equipped with either 32K BRAM (031-02431-000) or 128K BRAM (031-02565-000).

- Motor Node ID

(VSD applications – Software version C.OPT.01.16.307 or later)

(Style B Liquid Cooled Solid State Starter applications – Software version C.OPT.01.18.307 or later)

Only displayed when “Modbus” is selected for the Motor Communications Protocol setpoint above. Allows the Service Technician to enter the Modbus Address of the VSD Logic Board or Style B LCSSS Logic/Trigger Board. The Motor Node ID setpoint must match the Modbus Address assigned to these boards. Whenever the microboard is reading or writing to these devices, it transmits the address entered as the Motor Node ID setpoint. The device will only respond if the transmitted address matches the address assigned to the device. The chiller must be stopped with the Start-Run-Stop/Reset switch in the Stop/Reset position to change this setpoint. VSD applications: Enter “1” for the Motor Node ID setpoint. Then set the Modbus Address of VSD Logic Board 031-02506 to “1” by setting Switch SW3 position 1 to “ON with all other positions “OFF”. Style B Solid State Starter applications: Enter “1” for the Motor Node ID setpoint. Then set the Modbus Address of the Logic/Trigger Board 031-02505 to “1” by setting Switch SW1 position 1 to “ON” with all other positions “OFF”.

- Coastdown Time (software version C.OPT.01.16.307 and later) – Only appears when STANDARD is selected for the COASTDOWN setpoint. Sets the duration of the coastdown period. The time is programmable over the range of 240 (default) to 900 seconds or 150 (default) to 900 seconds as determined by the selection made for the CHILLER STYLE/COMPRESSOR setpoint on the Operations Screen. Refer to the CHILLER STYLE/COMPRESSOR setpoint.

- Condenser Temperature Range (software version C.OPT.01.19.307 and later) – Special order chill-

ers that operate at higher than standard condenser temperatures require higher condenser high pressure warning and safety thresholds. This setpoint allows the software to be used in either standard or high temperature applications. This setpoint is set at the factory at time of manufacture and requires an ADMIN password to change it. It is only visible when set to Extended. The selections are:

1. Standard – Uses standard high pressure warning and safety shutdown thresholds as follows: “Warning – High Pressure Limit” – Maximum allowable value is 162.5 PSIG; “Condenser – High Pressure” – Trip/reset threshold is 180/120 PSIG; “Condenser – High Pressure – Stopped” – Trip/reset threshold 160 PSIG.
2. Extended – Uses higher high pressure warning and safety shutdown thresholds as follows: “Warning – High Pressure Limit” – Maximum allowable value is 193.0 PSIG; “Condenser – High Pressure” – Trip/reset threshold is 200/140 PSIG; “Condenser – High Pressure – Stopped” – Trip/reset threshold is 170 PSIG.

- PRV Position (software version C.OPT.01.21.307 and later) – New production chillers after June 2009 can be equipped with an optional Pre-rotation Vanes Potentiometer, regardless of other options. This setpoint allows the software to be used in all YK chillers, whether equipped with the potentiometer or not. The PRV position will be shown on respective screens when Enabled; not shown when Disabled.

1. Enabled – Automatically set to this setting if Hot Gas Bypass or Variable Geometry Diffuser (VGD) is enabled on the OPERATIONS Screen or Motor Drive Type Setpoint is set to VSD or MVVSD. The actual connection point of the potentiometer is determined by the equipment configuration: If equipped with a VSD in YORK protocol configuration, it is connected to the ACC Board; in MODBUS protocol configuration, it is connected to the Microboard J7. If not equipped with VSD, but equipped with Hot Gas Bypass, the connection point is determined by which I/O Board is present: with I/O Board 371-02514-000, it is connected to this board; otherwise, it is connected to the Microboard J7. If not equipped with Hot Gas Bypass but equipped with a VGD, it is connected to the Microboard J7.
2. Disabled – Set to this position when not equipped with a PRV potentiometer. If equipped with a VSD, MVVSD or the Hot Gas Bypass or Variable Geometry Diffuser is enabled, this setpoint is automatically enabled and cannot be set to disabled.

- Heat Recovery (software version C.OPT.01.21.307 (and later) – Allows the heat recovery feature to be enabled or disabled.
- Head Pressure Control (software version C.OPT.01.21.307 (and later) – Allows the Head Pressure feature to be enabled or disabled.

Microboard Service Replacement

If the microboard is replaced within the warranty period, the defective board must be returned to YORK per the warranty return procedure. Use the return instructions and return address label provided with the replacement board.

To order a replacement Microboard for a YK Chiller, order part number 331-02430-601. This part number provides an 031-02430-001 Microboard that has been programmed with the latest version of the YK “Controls” software. It comes equipped with a BRAM (U38) and BIOS Eprom (U37). (Replacement Microboards cannot be ordered by the basic board part number of 031-02430-001). Refer to Replacement Parts List 160.54-RP1.

The Microboard is shipped with a label on the outside of the shipping box that lists the part number of the pre-programmed Microboard (331-02430-601), the basic Microboard part number (031-02430-001) and the version of the pre-programmed “Controls” software (for example, C.OPT.01.14.306 or later).

Microboard 031-02430-000 is supplied as replacement part from January 2004 until June 2006. After this date, microboard 031-02430-001 is supplied. This board is an upgraded version of the 031-02430-000 microboard and is backward compatible to YK chillers presently using the 031-01730-000 or 031-02430-000 microboards. The upgrade includes a larger BRAM and an additional RS-485 port on COM2 for MODBUS serial communications. This upgrade is necessary to operate with those motor drives that communicate with the microboard using Modbus communications: Medium Voltage Solid State Starter (MV SSS), Medium Voltage Variable Speed Drive (MV VSD), Variable Speed Drive (VSD) Modbus applications and Style B Liquid Cooled Solid State Starter (LCSSS) Modbus applications..

Summary of differences between 031-02430-000 and 031-02430-001 Microboards:

	031-02430-000	031-02430-001
BRAM	031-02431-000 (32KB)	031-02565-000 (128KB)
BRAM Socket	28 pin	32 pin
Program Jumper JP14	Non-removable wire	2-pin shunt type w/shunt removed
COM2 Serial Port	RS-232	RS-232 or RS485 as selected w/JP17. RS-485 is required for MVSSS, MVVSD, VSD and Style B LCSSS Modbus communications
Required “Controls” Software Version	Any version	C.OPT.01.15.xxx (or later) (see BRAM transfer exception below). MV VSD & VSD Modbus require C.OPT.01.16.xxx or later, Style B LCSSS MODBUS require C.OPT.01.18.307 (or later)
Application	Except MVSSS, MVVSD, VSD Modbus & Style B LCSSS Modbus	All including MVSSS, MVVSD, VSD Modbus & Style B LCSSS Modbus

3A

When replacing a microboard, it is sometimes desirable to transfer the BRAM from the defective board to the replacement board to save stored Setpoint, History or Sales Order data. Not all BRAM devices are compatible with all Microboards. Also, not all BIOS Eproms are compatible with all Microboards. The board will not function with incorrect memory components. Therefore, before attempting to transfer memory components between boards, refer to the following compatibility chart before proceeding:

Microboard	BRAM	BIOS Eprom
031-02430-001	031-02565-000*	031-02429-001
031-02430-000	031-02431-000	031-02429-001
031-01730-000	031-02028-000	031-01796-002

*Refer to the following BRAM transfer exception.

Transferring a 32KB BRAM from 031-02430-000 Board to 031-02430-001 Board:

For applications other than MV SSS, MV VSD and VSD Modbus applications, the 32KB BRAM (031-02431-000) from a 031-02430-000 board can be transferred to a 031-02430-001 board. This can be useful when it is desired to transfer a BRAM from one board to another to save stored setpoint, History or Sales Order data. In order to do this, the following must be performed:

1. Install a shunt over Program Jumper JP14. Use an unused black plastic shunt from JP9-12 (DO NOT USE JP1).
2. Install 32KB BRAM toward bottom of the BRAM socket (U38) so that there are 4 empty sockets at the top of the BRAM socket as shown.

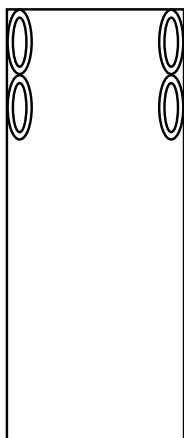

3. With this configuration, the board can be operated with software versions prior to or later than version C.OPT.01.15.301.

Program Card Service Replacement

Since one YK Program Card can be used to re-program other YK chillers, it is not necessary for an individual Service Technician to have more than one YK Program Card. Program Cards can be shared among Service Technicians where appropriate.

However, since chiller operating programs are occasionally revised, the Service Technician could have a Program Card that does not contain the latest program. Program Cards (031-02474-001) for YK chillers are available from the Baltimore Parts Distribution Center (PDC). The card received from the PDC is programmed with the latest version of the chiller operating program.

Program Cards can be re-programmed with the latest program version.

DOWNLOADING A PROGRAM FROM A PROGRAM CARD

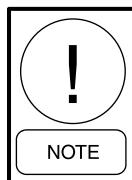

The Program Card Write Protect Switch must be in the "Write Protect" position!



There are 3 steps to the re-programming process: Erase, Program and Verification. Once the re-programming process is initiated, it automatically proceeds through these steps to completion. It cannot be manually terminated before completion. Therefore, once the process is initiated, the existing on-board program will be erased and replaced by the program in the Program Card. Before proceeding, be absolutely certain the Program Card is applicable to your chiller model. For example, if your chiller is a YK chiller, the Program Card used MUST be for a YK chiller. If a YS chiller program is downloaded into a YK chiller, for example, the chiller will be rendered inoperable until this procedure is repeated using the correct Program Card!

A label affixed to the Program Card contains the card version. The version is an alpha-numeric code that identifies the chiller model applicability, language package and program revision level. The version is as follows:

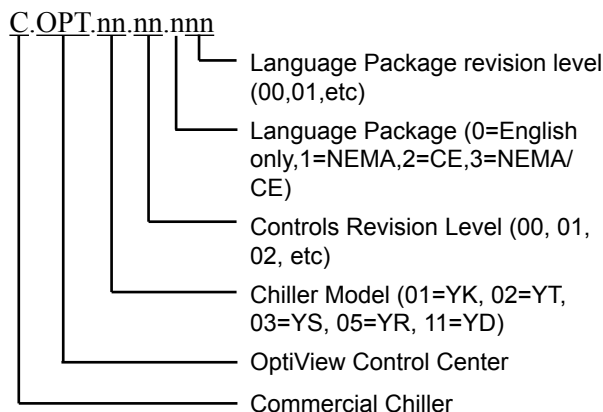

Download the program as follows:

1. Remove power to OptiView Control Center.
2. Remove protective cover from Microboard connector U33.
3. Reposition Microboard Program Jumper JP6 to pins 2 & 3 (left-hand pins).
4. Insert Program Card into Microboard connector U33.
5. Restore power to OptiView Control Center. A white screen appears displaying “Flash Checksum Test:” and Microboard 7-segment LED (U22) displays “Ch”. While this is displayed, the Microboard is performing a checksum test on the Program Card. This assures the integrity of the card before the download procedure can begin. If the checksum test fails, the card is defective or corrupted and the download procedure cannot be performed. If the checksum test passes, the “OptiView Flash Programmer” Screen is displayed.
6. Press START key to start the downloading process. A dialog box appears asking if you want to “Erase Onboard Flash and Re-Program from PcCard?”. **Do not proceed until you understand the above caution!**
7. Use the ► key to scroll to YES.
8. Press √ key. The following steps will be performed:
 - a. Erasing. During this procedure, the program in the Microboard Flash Memory will be erased. A green bar reflects the progress of this procedure. The red LED next to this bar illuminates while this procedure is in progress.
 - b. Programming. During this procedure, the program in the Program Card is downloaded into the Microboard Flash memory. A green bar reflects the progress of this procedure. The red LED next to this bar illuminates while this procedure is in progress.
 - c. Verifying. During this procedure, a checksum test is performed on the new program in the Microboard Flash Memory. A green bar reflects the progress of this procedure. The red LED next to this bar illuminates while this procedure is in progress.

The Microboard 7-segment LED Display (U22) displays the steps of the programming process while they are in effect. During the Erasing procedure, “Er” displayed. During the Programming procedure, “Pr” is displayed. During the Verifying procedure, “Ch” is displayed.

At the completion of the re-programming process, if it is successful, “Flash Has Been Successfully Programmed” is displayed and “Operation Successful” is displayed in the Status Code box. Otherwise, a message in the status box indicates the step that failed.

9. Remove power from OptiView control center.
10. Remove Program Card from Microboard connector U33.
11. Install protective cover on Microboard connector U33.
12. Reposition Microboard Program Jumper JP6 to pins 1 & 2 (right-hand pins) pins.
13. Apply power to OptiView Control Center. The re-programming procedure is now complete.

3A

TABLE 3

MICROBOARD 031-02430-000 AND 031-02430-001 PROGRAM JUMPERS

JP1 – Parallel Port Enable/Disable. Used to enable and disable the parallel port in the microprocessor. Since the board is presently not populated with a parallel port connector, this jumper must be in the Disable position.

Pins 1-2: Enables Parallel Port

Pins 2-3: Disables Parallel Port. Must be in this position for correct microboard operation.

JP2 – Display power and logic levels Determines the power supply voltage applied to the display. Pins 1-2: +5VDC SHARP LQ10D367/368 (031-01774-000) displays. Pins 2-3: +3.3VDC SHARP LQ104V1DG61 (031-02886-000) and LG Semicon LP104V2-W (031-02046-000) displays.

JP3 – Display backlight enable signal level polarity. Jumper must be positioned according to the voltage level required to turn on the Display Backlight. Pins 1-2: 0VDC – not used. Pins 2-3: +12VDC or +5VDC as determined by position of JP4. SHARPLQ10D367/368 (031-01774-000), SHARP LQ104V1DG61 (031-02886-000) and LG Semicon LP104V2-W (031-02046-000) displays.

JP4 – Display Backlight enable signal logic levels. Determines the logic levels of the Backlight Enable signal. Pins 1-2: +12VDC/0VDC – not used. Pins 2-3: +5VDC/0VDC SHARP LQ10D367/368 (031-01774-000), SHARP LQ104V1DG61 (031-02886-000) and LG Semicon LP104V2-W (031-02046-000) displays.

JP5 – Display Backlight power. Determines the power supply voltage applied to the Display Backlight Inverter Board. Pins 1-2: +12VDC. SHARP LQ10D367/368 (031-01774-000) and SHARP LQ104V1DG61 (031-02886-000) and LG Semicon LP104V2-W (031-02046-000) displays. Pins 2-3: +5VDC. Not used.

JP6 – Boot-up source. Determines whether the boot-up is performed from the Program Card or Eprom U37. Pins 1-2: Boots-up from Eprom U37. Must be in this position unless re-programming from the Program Card. Pins 2-3: Boots-up from the Program Card. Must be in this position when re-programming from the Program Card.

JP7, JP8 – Display brightness control technique. Determines whether the display brightness is controlled by a variable resistance or a variable voltage.

IN: Variable voltage (0-5.0VDC). SHARP LQ10D367/368 (031-01774-000) and SHARP LQ104V1DG61 (031-02886-000), and LG Semicon LP104V2-W (031-02046-000) displays.

OUT: Variable resistance – not used

JP9 – Not Used.

JP10 – Factory mounted thermal flow sensor – evaporator. Heat recovery chillers and new production chillers after June 2009.

Pins 1-2: not used

Pins 2-3: Heat Recovery chillers and new production chillers after June 2009

JP11 – Factory mounted thermal flow sensor – condenser. Heat recovery chillers and new production chillers after June 2009.

Pins 1-2: not used

Pins 2-3: Heat Recovery chillers and new production chillers after June 2009

JP12 – Factory mounted thermal flow sensor – heating condenser water. Heat Recovery chillers

Pins 1-2: not used

Pins 2-3: Heat Recovery chillers

JP13 – Watchdog Enable/Disable. Soldered wire jumper.



Never disable the watchdog protection. Severe compressor or chiller damage could result. The ability to disable the watchdog protection is provided for factory testing only.

IN: – Watchdog enabled

OUT: – Watchdog disabled

JP14 – BRAM size (Microboard 031-02430-001 only) – Must be positioned according to the size of the BRAM installed on the board.

IN: 32K (BRAM 031-02431-000)
OUT: 128K (BRAM 031-02565-000)

(For 031-02430-000 microboards, this is a non-removable wire jumper soldered in place at time the board is manufactured. It must NOT be removed by field service personnel.

JP16 – Not Used

JP17 – COM 2 Serial port mode (microboard 031-02430-001 only). This port can operate in either RS-232 or RS-485 mode, depending on the position of this jumper.

PINS 1-2: RS-485 (required for MV SSS, MV VSD and those Variable Speed Drives and Style B Liquid Cooled Solid State Starters that communicate with the microboard using Modbus protocol.
PINS 2-3: RS-232 (not used)

JP21 – Factory mounted thermal-type flow sensor – evaporator. Style “F” and later chillers only.

Pins 1-2: Not Used
Pins 2-3: Style F and later chillers with factory mounted evaporator thermal-type flow sensor.

JP22 – Factory mounted thermal-type flow sensor – condenser. Style “F” and later chillers only.

Pins 1-2: Not Used
Pins 2-3: Style F and later chillers with factory mounted condenser thermal-type flow sensor.

JP23 – Remote Current Limit Setpoint (J22) type. Configures analog input for 0-10VDC, 2-10Vdc, 0-20mA or 4-20mA.

OUT: Allows 0-10VDC or 2-10VDC input on J22-1

Pins 1-2: Allows a 0-20mA or 4-20mA input on J22-2
Pins 2-3: Not used.

JP24 – Remote Leaving Chilled Liquid Temperature Setpoint (J22) type. Configures analog input for 0-10VDC, 2-10Vdc, 0-20mA or 4-20mA.

OUT: Allows 0-10VDC or 2-10VDC input on J22-3

Pins 1-2: Allows a 0-20mA or 4-20mA input on J22-4
Pins 2-3: Not used.

JP27 – COM 4 serial communications port. Configures COM 4 port for either RS-485 (COM 4A) or RS-232 for MicroGateway board (COM4B).

Pins 1-2: Enables port 4A. Allows an RS-485 connection to microboard J11. Not used.
Pins 2-3: Enables port 4B. Allows an RS-232 connection to microboard J2 for Microgateway communications.

3A

TABLE 4

MICROBOARD 031-02430-000 AND 031-02430-001 PROGRAM SWITCHES

SW1-1 – Refrigerant Selection. Must be set according to the refrigerant type installed in chiller.

ON – R134a
OFF – R22

SW1-2 – Liquid Type. Must be set according to whether the chiller is cooling water or brine solution.

ON – Brine. Leaving Chilled Setpoint range is 10°F to 70°F.
OFF – Water. Leaving Chilled Setpoint range 38°F (36°F if Smart Freeze enabled) to 70°F.

SW1-3 – Diagnostics. Enables or Disables the software diagnostics. Refer to SECTION 24 of this manual.

ON – Enables diagnostics. Disables normal chiller operation.

OFF – Disables diagnostics. Enables normal chiller operation.

SW1-4 – Not used.

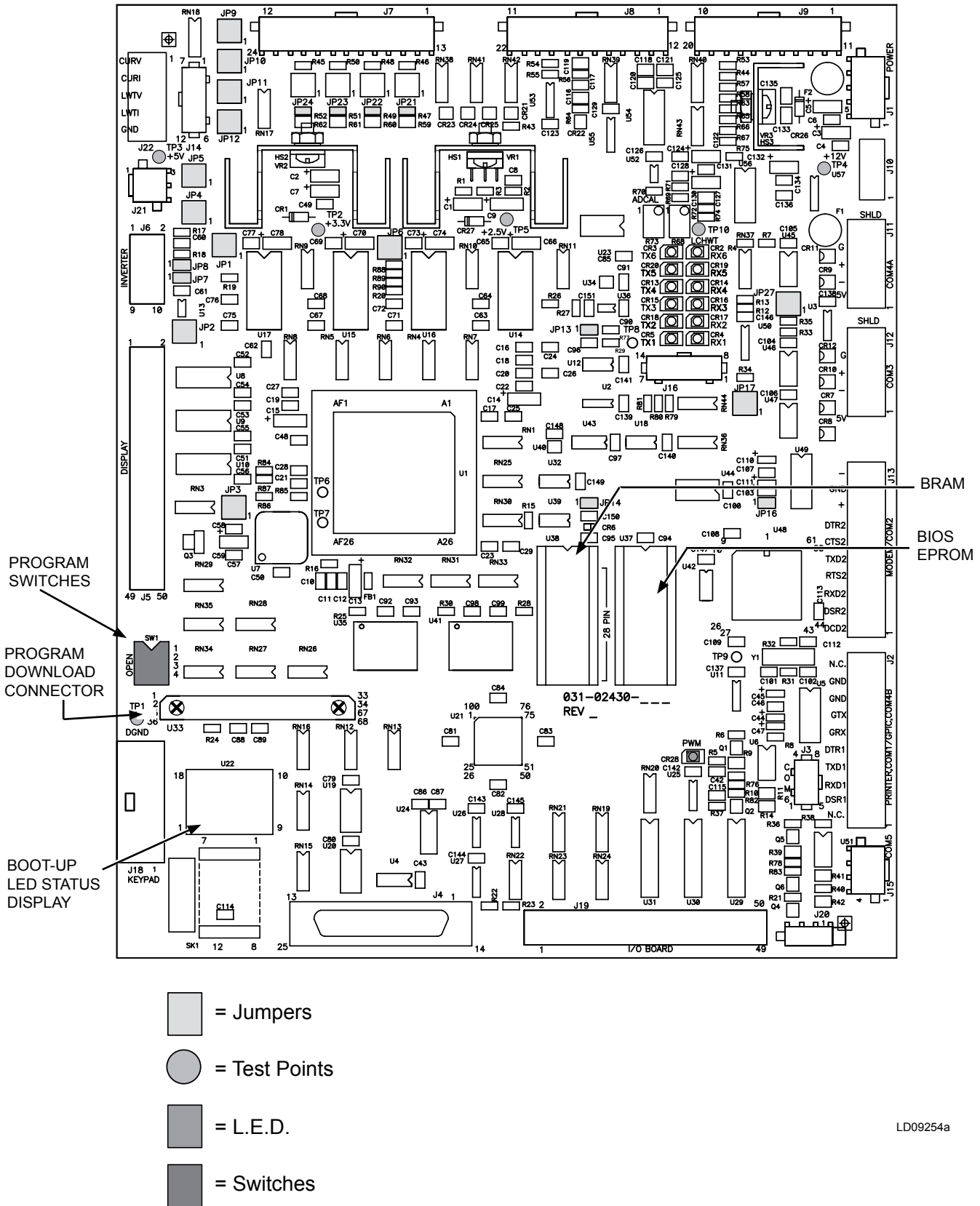

LD09254a

FIG. 7A – MICROBOARD 031-02430-000 AND 031-02430-001

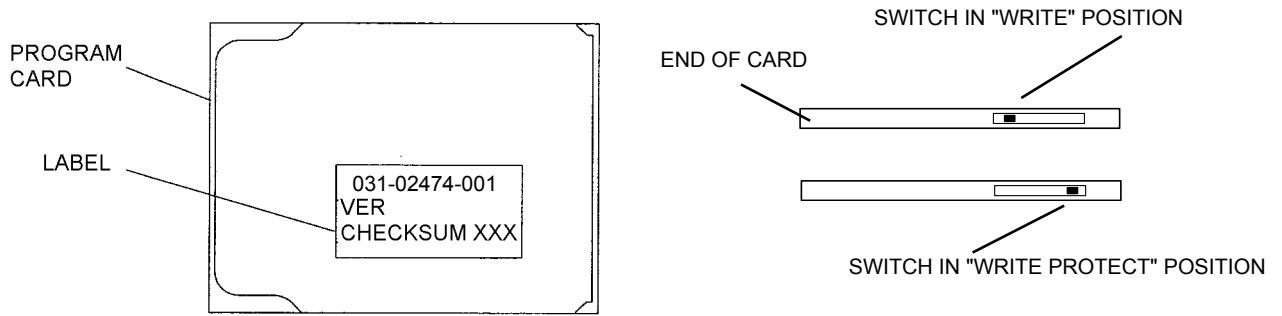

3A

FIG. 8A – PROGRAM CARD 031-02474-001

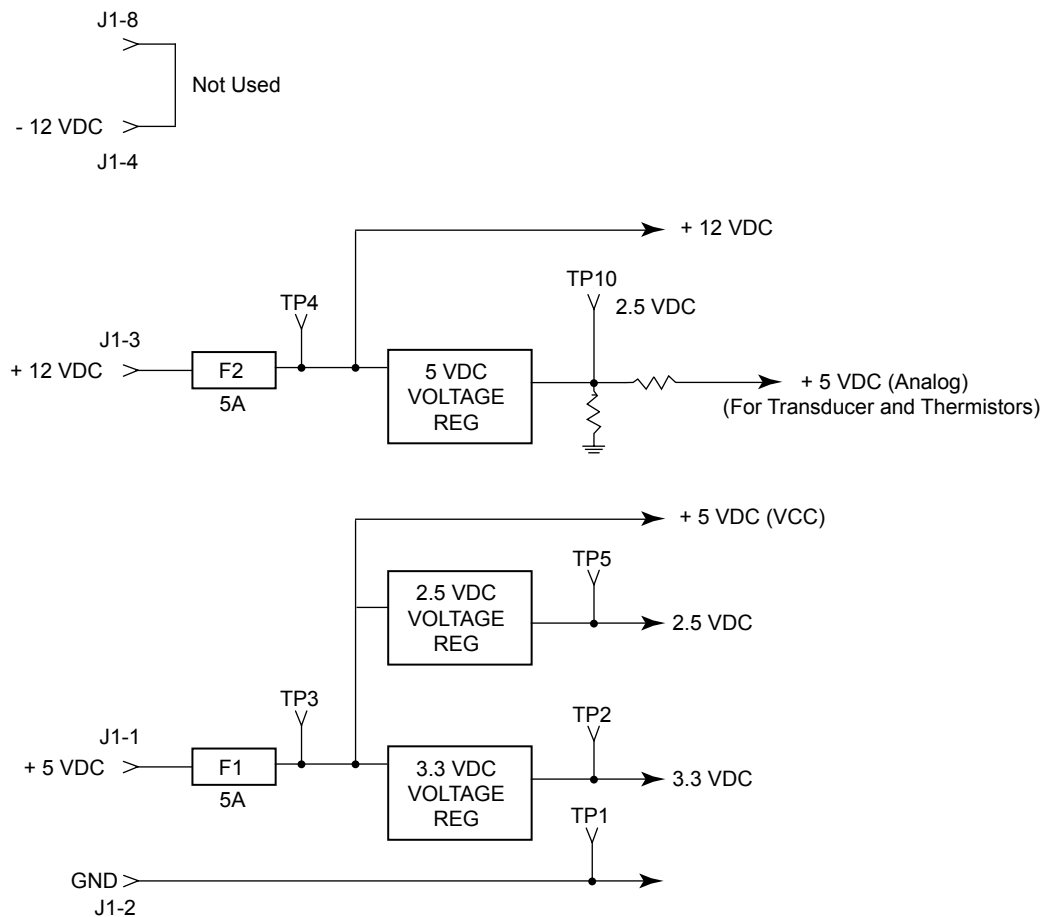

LD09255A

FIG. 9A – MICROBOARD (031-02430-000 AND 031-02430-001) DC POWER SUPPLY TEST POINTS

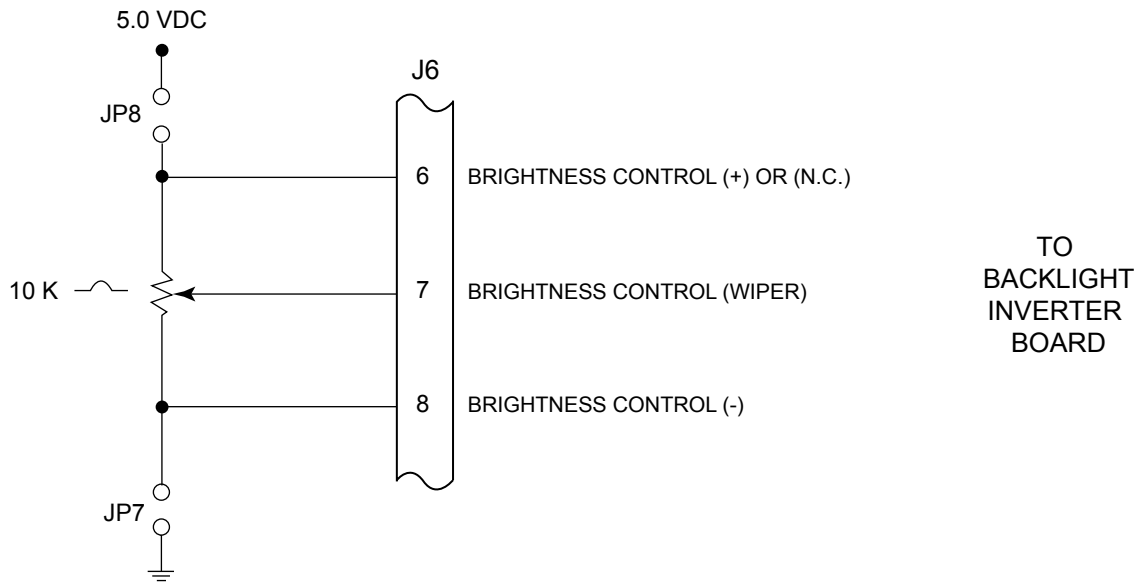

NOTES:

1. J6-6 not connected (N.C.) to Backlight Inverter Board when display is manufactured by Sharp or NEC.
2. The position of Program Jumpers JP7 & JP8 determine the output at J6-7; In = Variable Voltage; Out = Variable Resistance. Refer to Program Jumper Listing in Table 3 for applications.
3. Potentiometer is actually an integrated circuit that is the electrical equivalent of a 10K potentiometer.

LD04054

FIG. 10A – MICROBOARD LAMP DIMMER CIRCUIT

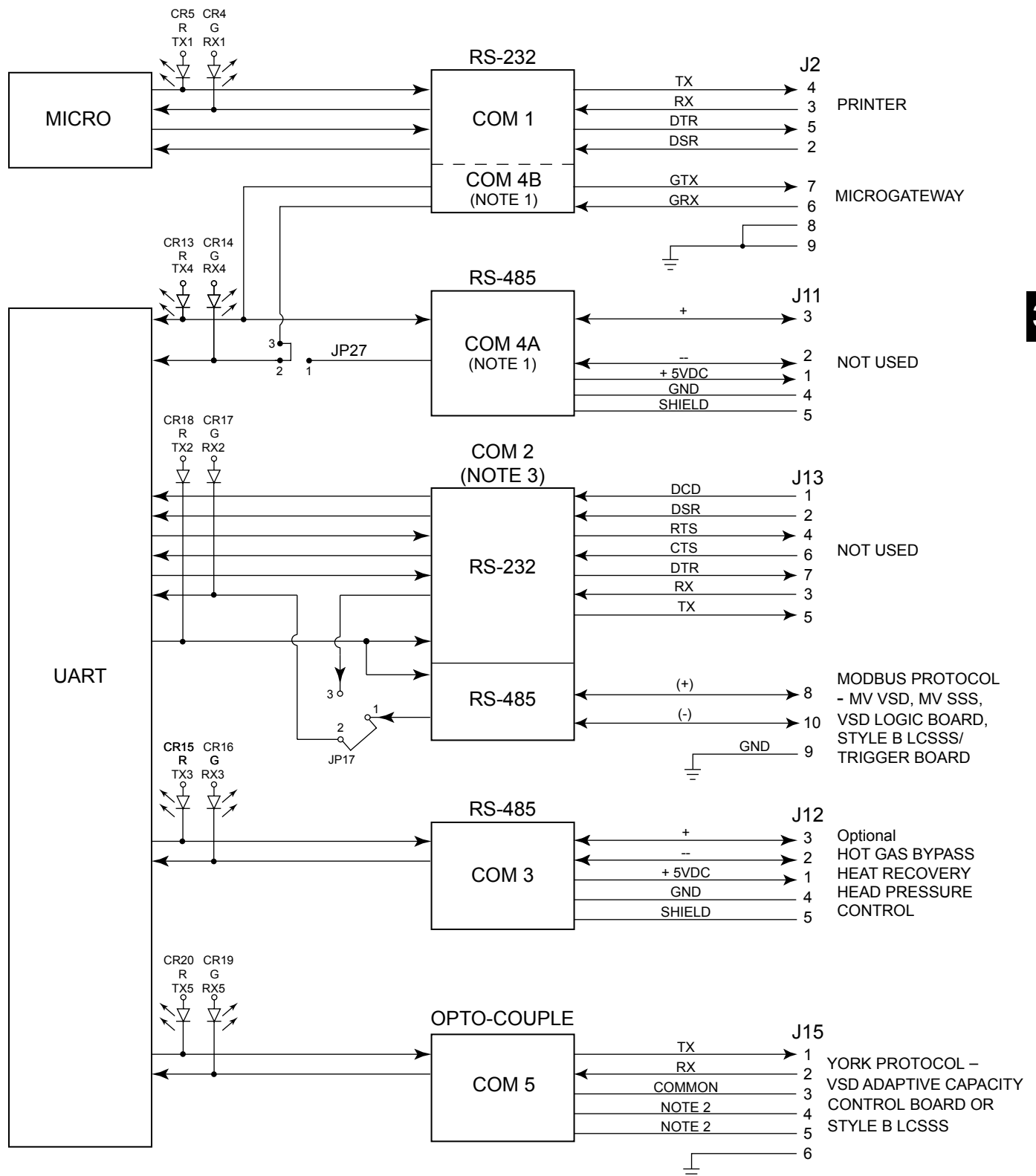

NOTES:

1. Microboard Program Jumper JP27 determines whether COM 4A or 4B can be used. 1 & 2 - 4A, 2 & 3, 4B. Refer to Table 3.
2. J15-4 Loop-Around Test IN. J15-5 Loop-Around Test OUT. Refer to FIG. 55 for details.
3. The COM 2 port has two selectable serial modes. It can operate in either RS-232 or RS-485 mode, depending upon the position of program jumper JP17 as follows: On pins 1 & 2 for RS-485 operation. On Pins 2 & 3 for RS-232 operation. Refer to Table 3. The COM 2 RS-485 port is not present on 031-02430-000 microboard.

LD07788F

FIG. 11A – MICROBOARD SERIAL DATA COMMUNICATIONS PORTS

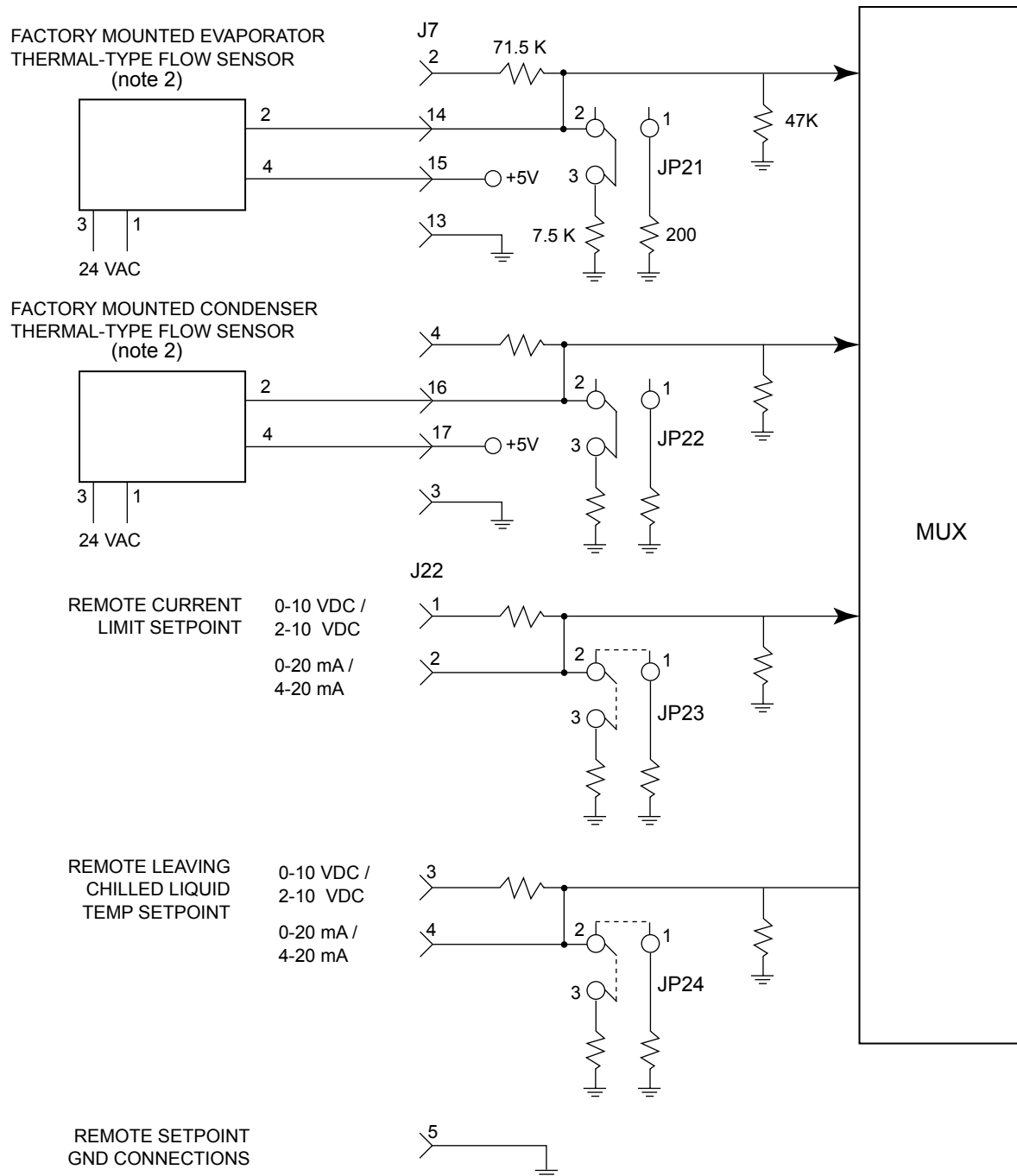

LD09565

NOTE:

1. Program Jumpers JP23 – JP24 must be positioned on pins 1-2 or 3-4 according to input signal type. Refer to Table 3.
2. On new production chillers prior to June 2009, the Thermal type flow sensors are connected to Microboard J7 as shown above. Program Jumpers JP21 and JP22 must be on pins 2-3. On new production chillers after June 2009, the Thermal type flow sensors are connected to Microboard J14 (ref FIG. 12B).

FIG. 12A – CONFIGURABLE ANALOG & REMOTE SETPOINT INPUTS

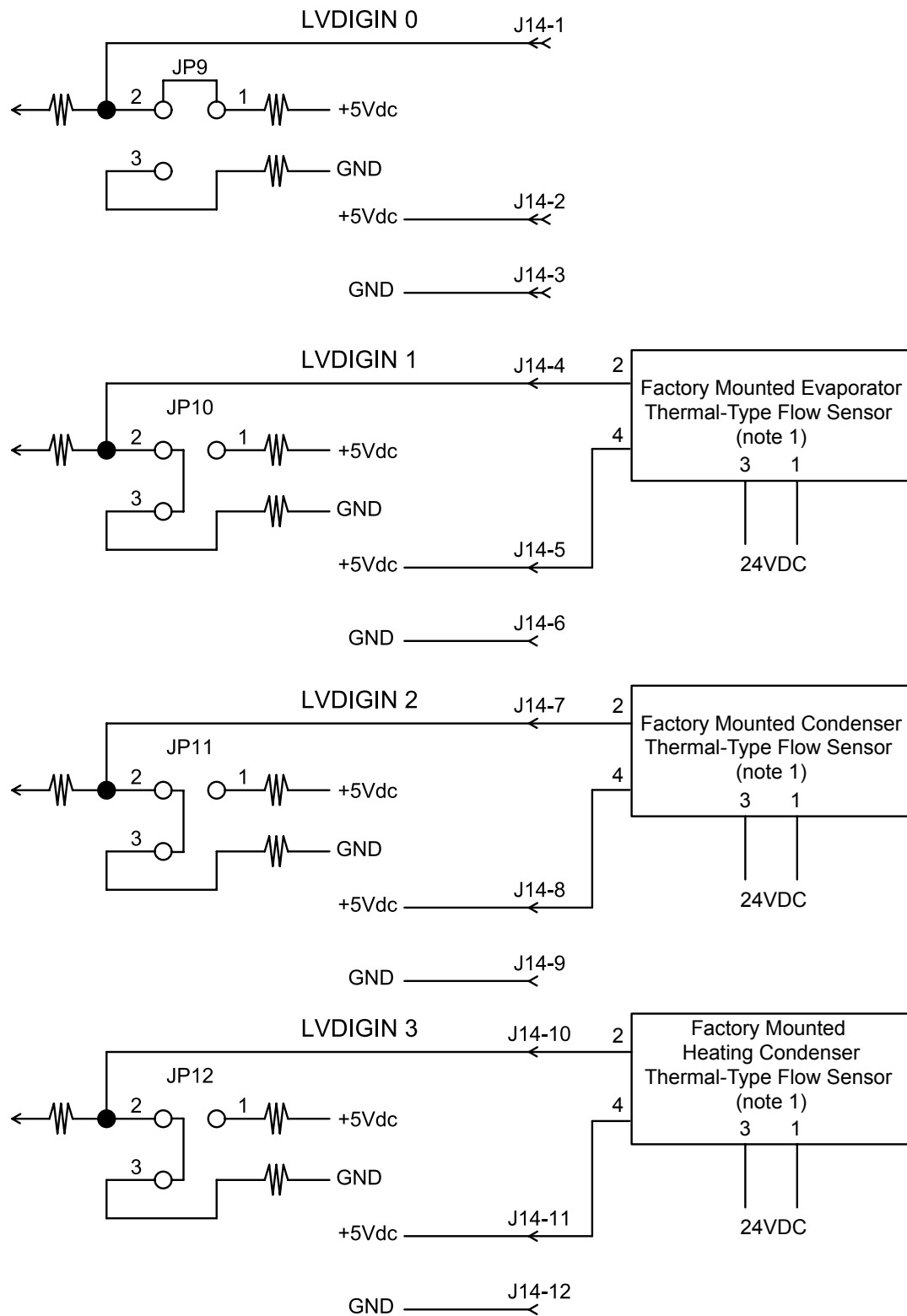

LD12827a

NOTE:

1. On new production chillers after June 2009, the Thermal type flow sensors are connected to Microboard J14 as shown above. Program Jumpers JP10 through JP12 must be positioned on pins 2-3 and software version C.OPT.01.21.307 (and later) is required. On new production chillers prior to June 2009, the Thermal type flow sensors are connected to Microboard J7 (ref FIG. 12A).

FIG. 12B – LOW VOLTAGE DIGITAL INPUTS

SECTION 4

I/O BOARD

(REFER TO FIG. 13 - 17)

The **I/O (input/output) Board** conditions the Digital Inputs for the Microboard and conditions the Microboard's Digital Outputs for application to other components and devices. The left side of the I/O Board performs the Digital Inputs function; the right side performs the Digital Outputs function. Refer to FIG. 13.

Digital Inputs are on/off inputs to the Microboard from relay and switch contacts, such as flow switches, start/stop switch, and remote cycling/safety devices (ref. FIG. 14). The Micro reads the state of these contacts and reacts per the Program instructions. The contact voltage is 115 VAC when closed and 0VAC when open. These voltages are not suitable for direct input to the Microboard. Therefore, the I/O Board converts the 115VAC/0VAC contact voltages to 0VDC/+5VDC logic level inputs for the Microboard. Individual Opto-coupler circuits (ref. FIG. 15) perform the conversion for each Digital Input. When the input is 115VAC, the output will be 0VDC; when the input is 0VAC, the output will be +5VDC.

Field connected Digital Inputs, such as those from external devices that cycle the chiller, are connected to terminal strip TB4 (ref. FIG. 14). These inputs are in the form of dry contacts connected as shown in FIG. 16. The 115VAC power source that is switched by the remote contacts is supplied by the I/O Board TB4-1. There are multiple TB4-1 terminals located adjacent to the field input connections, as shown in FIG. 13 and 14.

Digital Outputs are on/off outputs from the Microboard that control solenoid valves, motor contactors, actuators, system relays and provide operating status to external devices (ref. FIG. 17). Per Program instructions, the Microboard energizes and de-energizes these devices. The coils of these devices operate on 115VAC and therefore cannot be directly connected to the Microboard. The Digital Outputs section of the I/O Board contains +12VDC coil relays that are driven by the Microboard's logic level outputs. The contacts of these +12VDC relays operate the external 115VAC coil devices. On the I/O Board, one side of each of the relay coils is permanently connected to +12VDC at J19-26/27. The other side of each relay coil is connected to the Microboard via I/O Board connector J19. The Microboard energizes each relay by driving the appropriate input at J19 to logic

low voltage level (ground potential). The DC voltage at the appropriate input pin at J19 will be a logic high (>+10VDC) when the Microboard is commanding a relay to de-energize; logic low (<+1VDC) when commanding a relay to energize.

Relay K18 is different from all other relays on the I/O Board; it has a 115VAC coil. It provides the start/stop signal to the Compressor Motor Starter and provides **Compressor Run** status to remote devices (ref. FIG. 17). Relay K18 is controlled by DC relays K13 (start) and K14 (stop). To start the compressor motor, the Microboard energizes K13 and K14 simultaneously. The 115VAC at TB1-6 is applied to the coil of K18 via K13 contacts, energizing K18. Approximately 0.2 seconds later, K13 is de-energized. K18 remains energized through K14 contacts and holding contacts of K18. To stop the compressor motor, the Microboard de-energizes K14. To prevent sags in Utility Power from chattering K18, the holding contact of K18, along with the contact of K13, creates an anti-chatter circuit for relay K18. Once energized, K18 cannot be re-energized until K13 is again energized; this will not occur until after a controlled shutdown has occurred and another start sequence has been initiated.

There are conditions external to the I/O Board required to energize relay K18. The 115VAC will be present at TB1-16 only if the motor controller contacts "CM" are closed and the circuit between external Terminal Strip TB6-1 and TB6-53 is closed. The "CM" are located on the CM-2 Board (relay K1), Electro-Mechanical starter applications, the Solid State Starter Logic Board (relay K1), Solid State Starter applications or a relay mounted on the Variable Speed Drive Logic Board on Variable Speed Drive applications. The High Pressure safety switch "HP", must be closed and the **RUN** Switch "1SS" must be in the **RUN** position.

Triacs are used to control the Pre-rotation Vanes actuator, Refrigerant Level Variable Orifice actuator and Variable Geometry Diffuser actuator (certain compressors only) (ref. FIG. 17, 52 and 64A). An actuator has an open winding and a close winding. Current flowing through a winding will cause the actuator shaft to rotate in the respective direction. Each winding is controlled by

a Triac. When a Triac is turned on, it permits current to flow through the actuator winding, causing the actuator shaft to rotate. Under Program control, the Microboard turns the Triacs on and off by applying control signals to the respective **Triac Driver**. The Triac Driver is an optocoupler device that isolates the Microboard low voltage circuits from the higher actuator voltages. To turn on the Triac, the Microboard drives the Triac Driver input to logic low (<+1VDC) level. The Triac driver responds by shorting the Triac GATE to Triac terminal 2. To turn the Triac off, the Microboard opens its input to the Triac Driver and allows the input to pull up to +12VDC. The Triac Driver responds by opening the short from triac Gate to Triac terminal 2. A voltmeter can be used to determine if a Triac is turned on or off. Measure across the Triac; from Triac terminal 1 to Triac terminal 2. When the Triac is turned off, the voltage will be approximately 20 to 30VAC; when turned on, it will be <10VAC.

The Pre-rotation Vanes Actuator and Variable Geometry Diffuser actuator are manufactured by Barber-Coleman. This actuator has three windings; a Field winding and two direction windings. One direction winding produces clockwise rotation, the other produces counterclockwise rotation. The 115VAC applied to the Field Winding induces a 20 to 30VAC voltage into each of the direction windings. The desired rotation is produced by shorting the Actuator common terminal to the appropriate direction terminal, causing current to flow in the direction winding. As described above, Triacs control the current through the open and close windings.

The Refrigerant Level Variable Orifice Actuator on new production chillers is manufactured by Belimo. This actuator has two windings; open and close. One winding produces clockwise rotation and one produces counterclockwise rotation. This actuator operates from 24VAC. As described above, Triacs are turned on to allow current to flow through the appropriate winding to produce the desired rotation. If the OptiView Control Center is retrofit to an existing chiller, it could be equipped with a Barber-Coleman Level Actuator that operates as described above.

Chillers equipped with the Variable Geometry Diffuser are supplied with and require I/O Board 031-01743-002. This board is populated with the required Triacs Q3 and Q4 that apply the open and close signals to the Variable Geometry Diffuser ring actuator. Refer to Variable Geometry Diffuser Section 22A.

RELAY TIMING

Under Program control, the relays are energized and de-energized producing contact operation as follows. Unless otherwise noted, contact rating is 5 amps resistive or 2 Amps inductive @ 250VAC.

K0 - Chilled Water Pump Starter (TB2-44/45)

Dry closure contacts. When the chiller is started, the Contacts close 13 seconds after the start of "System Prelube". Normally, they open coincident with the completion of "System Coastdown" with the following exceptions:

- a. If a "Leaving Chilled Liquid - Low Temperature" cycling shutdown occurs, they do not open at the completion of "System Coastdown". They remain closed for the duration of the shutdown or until the Keypad COMPRESSOR switch is placed in the Stop-Reset (O) position, whereupon they open.
- b. If Microboard Program Switch SW1-8 is in the ON position, they do not open at the completion of "System Coastdown" when the chiller shuts down on a "Multiunit Cycling - Contacts Open" or "System Cycling - Contacts Open" cycling shutdown. They remain closed for the duration of the shutdown or until the Keypad COMPRESSOR switch is placed in the Stop-Reset (O) position, whereupon they open.

K1 - Anticipatory Alarm (TB2-55/56)

Dry closure contacts. Contacts close when one of the following Warning messages is Displayed. On most warnings, the contacts automatically open when the warning condition is no longer present. On those warnings marked with an asterisk, the contacts will open only after the warning condition is no longer present and the WARNING RESET key is pressed when logged in at OPERATOR access level or higher.

Real Time Clock Failure, Condenser or Evaporator Transducer Error*, Refrigerant Level Out of Range, Standby Lube-Low Oil Pressure*, Setpoint Override*, Condenser-High Pressure limit, Evaporator-Low Pressure Limit, Vanes Uncalibrated-Fixed Speed, Harmonic Filter-Operation Inhibited, Harmonic Filter-Data Loss, Harmonic Filter-Input Frequency Out Of Range. The following only applies to Flash Memory Card version C.MLM.01.05.xxx and later – Excess Surge Detected*, Surge Detected – Excess Surge Limit.

K2 - Remote Mode Ready to Start (only operational in Digital, Analog or ISN Remote mode)(TB2-26/27)

Dry closure status contacts that are closed to indicate to a Remote device that the chiller will start upon receipt of a remote start signal. The contacts open coincident with any Cycling or Safety shutdown or anytime the Keypad COMPRESSOR switch is placed in the Stop-Reset (O) position. On Cycling shutdowns, the contacts will close when the cycling condition clears. On safety shutdowns, the contacts will close only after the Safety condition clears, a manual reset is performed by placing the COMPRESSOR switch in the Stop-Reset (O) position and then back to the RUN (I) position.

K3 - Safety Shutdown Status (TB2-42/43)

Dry closure status contacts. They close coincident with a Safety shutdown. They remain closed until the safety condition clears and a manual reset is performed by placing the COMPRESSOR switch in the Stop-Reset(O) position, whereupon they open.

K4 - Cycling Shutdown Status (TB2-40/41)

Dry closure status contacts. They close coincident with a Cycling shutdown. They remain closed until the cycling condition clears, whereupon they open.

K5 - Condenser Motor Pump Starter (TB2-150/151) (applies to Flash Memory Card version C.MLM.01.04.xxx and later)

Dry closure contacts. Contacts close coincident with beginning of "SYSTEM RUN". They open coincident with the beginning of "SYSTEM COASTDOWN" unless the chiller is equipped with the Mod "B" Solid State Starter. On Mod "B" Solid State Starter applications, the contacts remain closed at shutdown until all SCR Heatsink temperatures are $\leq 105^{\circ}\text{F}$ or a maximum of 45 minutes.

If it is desired to supply the dry contacts with 115VAC power from the OptiView Control Panel to control the Condenser Pump Motor Starter, a field installed wire must be connected from TB5-22 to I/O Board TB2-150. Then connect I/O Board TB2-151 to the Condenser Pump Motor Starter.

K6-K 9 - Not Used

K10 - Oil Heater ("P" compressors and all style F and later chillers equipped with Flash Memory Card version C.MLM.01.07.xxx or later version) (TB1-64/17)

Contacts operate the same as K15.

K11 - Oil Pump Starter (TB 1-29/1) (Style C and earlier chillers)

In automatic operation, contacts close 13 seconds after "System Prelube" is initiated. Contacts open at completion of "System Coastdown". In manual Oil Pump operation, the contacts close for the duration of manual pump operation. Anytime the chiller is not in "System Run" or "System Coastdown" and a motor current value of $>15\% \text{FLA}$ is detected, the contacts close until motor current is no longer detected, whereupon a complete "System Coastdown" is performed. If Standby Lubrication is enabled, contacts close for 2 minutes every 24 hours since the oil Pump was last automatically or manually run.

K12 - Oil Return Solenoid (all styles, fixed or variable speed oil pump). Liquid Line Solenoid (style D and later chillers - "J" compressor only, variable speed oil pump). Vent line Solenoid (style C and earlier chillers, fixed speed oil pump). (TB1-61)

Contacts close 1 minute after "System Run" is initiated. They open on chiller shutdown coincident with the beginning of "System Coastdown".

With software version C.OPT.01.21.307 (and later), to avoid an "Oil - Low Temperature Differential" condition from preventing a chiller start after running at low load conditions for extended periods, the solenoid is cycled as follows while the chiller is running for P, Q and H9 compressors only: When the Oil Sump Temperature is less than the OIL RETURN MIN Setpoint, close (de-energize) the Oil Return Solenoid by de-energizing K12 relay. When the Oil Sump Temperature is greater than the OIL RETURN MIN Setpoint + 7°F , open (energize) the Oil Return Solenoid by energizing K12 relay. During coastdown and when not running, the solenoid operation is not changed from standard logic, it remains closed. During startup the operation is not changed from standard logic, it remains closed for 1 minute after System Run.

K13 - Compressor Motor Starter (start) (TB1-6/16)

Contacts close coincident with the beginning of "System Run". They remain closed for 0.2 seconds and then open.

K14 - Compressor Motor Stop (stop) (TB 1-6/16) Contacts close coincident with the beginning of “System Run”. They remain closed for the duration of “System Run”. They open coincident with the beginning of “System Coastdown”.

K15 - (TB1 -34/1)Oil Heater (Style D/E all compressor codes except “P”; Variable Speed Oil Pump)

Contacts are open whenever the Oil Pump is operating. When the Oil Pump is not operating, the contacts are operated to maintain the Oil Temperature at a target value of 50°F above the Condenser Saturated Temperature from a minimum of 110°F to a maximum of 160°F. The contacts close when the Oil Temperature decreases to 4°F below target value; open at 3°F above the target value.

Liquid Line Solenoid (Style C and earlier chillers, fixed speed oil pump)

- Electro-Mechanical and Solid State Starter applications: Contacts close 1 minute after “System Run” is initiated.
- Compressor Motor Variable Speed Drive applications: After chiller has been running for ≥ 1 minute, contacts close if oil temperature reaches $> 140^\circ\text{F}$. They remain closed until the oil temperature decreases to $< 135^\circ\text{F}$, whereupon they de-energize.

K16 - High Speed Thrust Solenoid (Style C and earlier chillers; Fixed Speed Oil Pump) (TB1-62/1)

Contacts close 15 seconds after “System Run” is initiated. They open on chiller shutdown coincident with the beginning of “System Coastdown”.

K17 - Condenser Motor Pump Starter (TB1-164)(If chiller is equipped with Mod “B” Solid State Starter, use K5 above)

Contacts operate the same as K14.

K18 - Compressor Motor Starter (TB5-22/25) Run Status (TB2-35/36)

Contacts operate the same as K14.

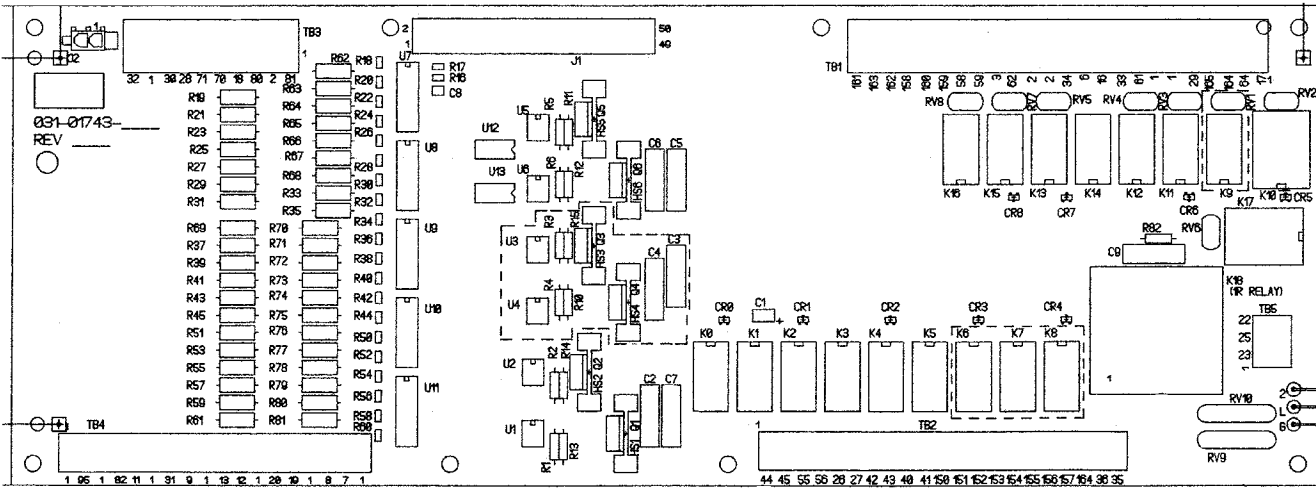

FIG. 13 – I/O BOARD

LD04055

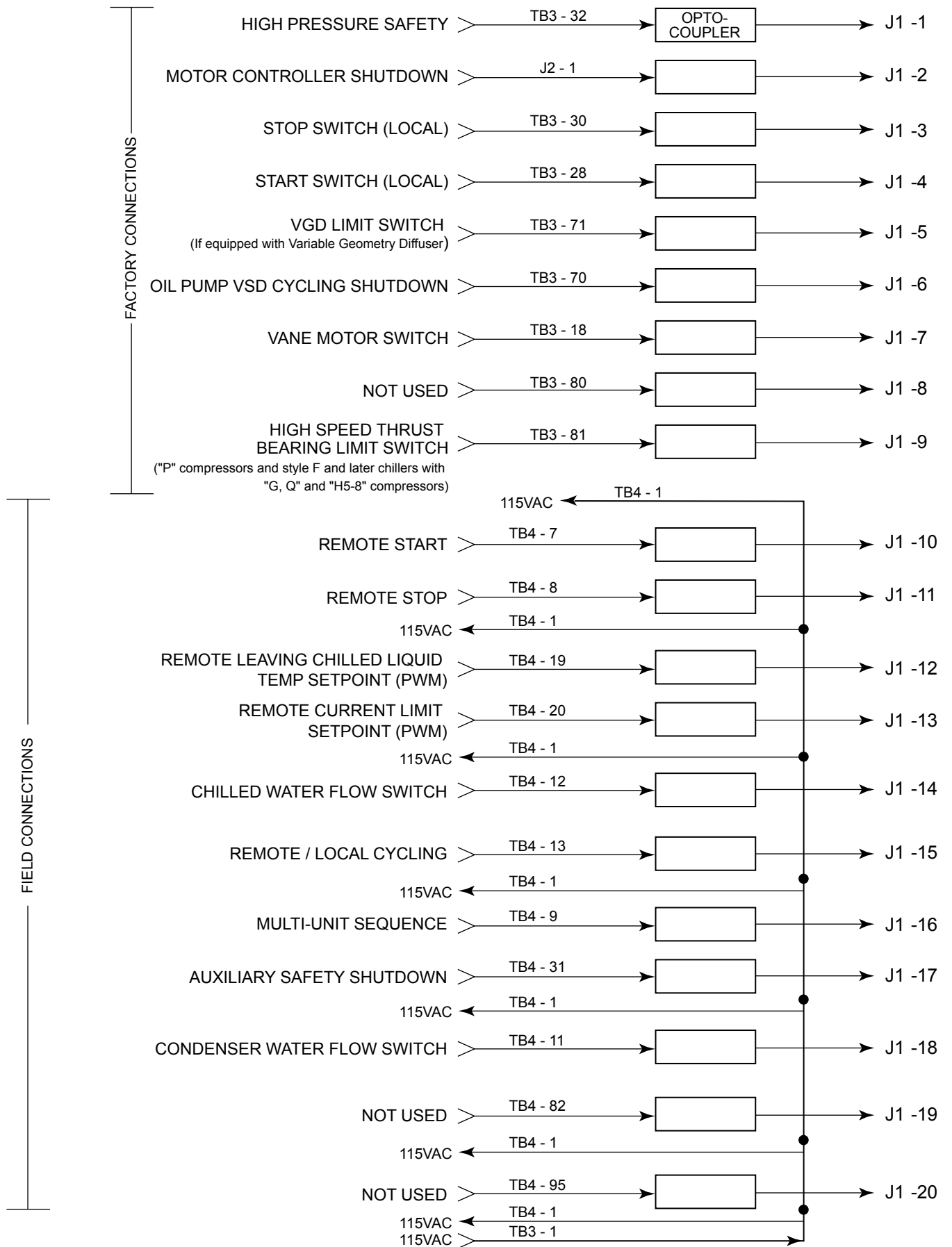
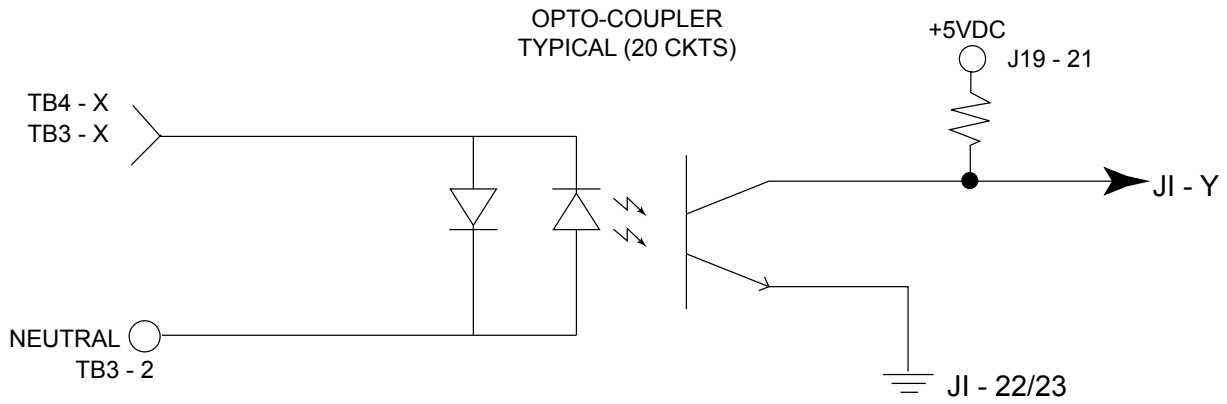

FIG. 14 – I/O BOARD DIGITAL INPUTS

LD09566



LD04057

FIG. 15 – I/O BOARD TYPICAL OPTO-COUPLER CIRCUIT

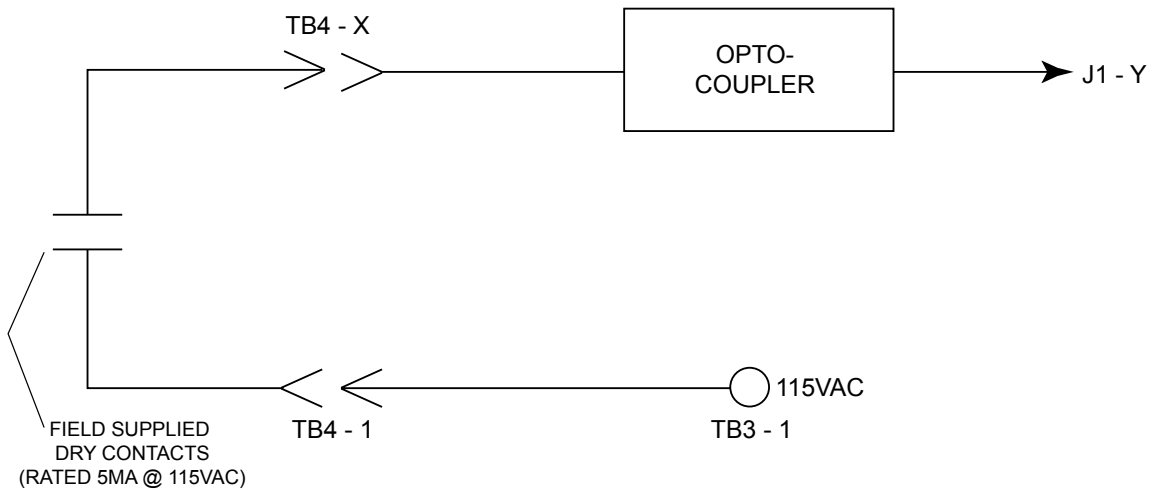

LD04058

FIG. 16 – I/O BOARD TYPICAL FIELD CONNECTIONS

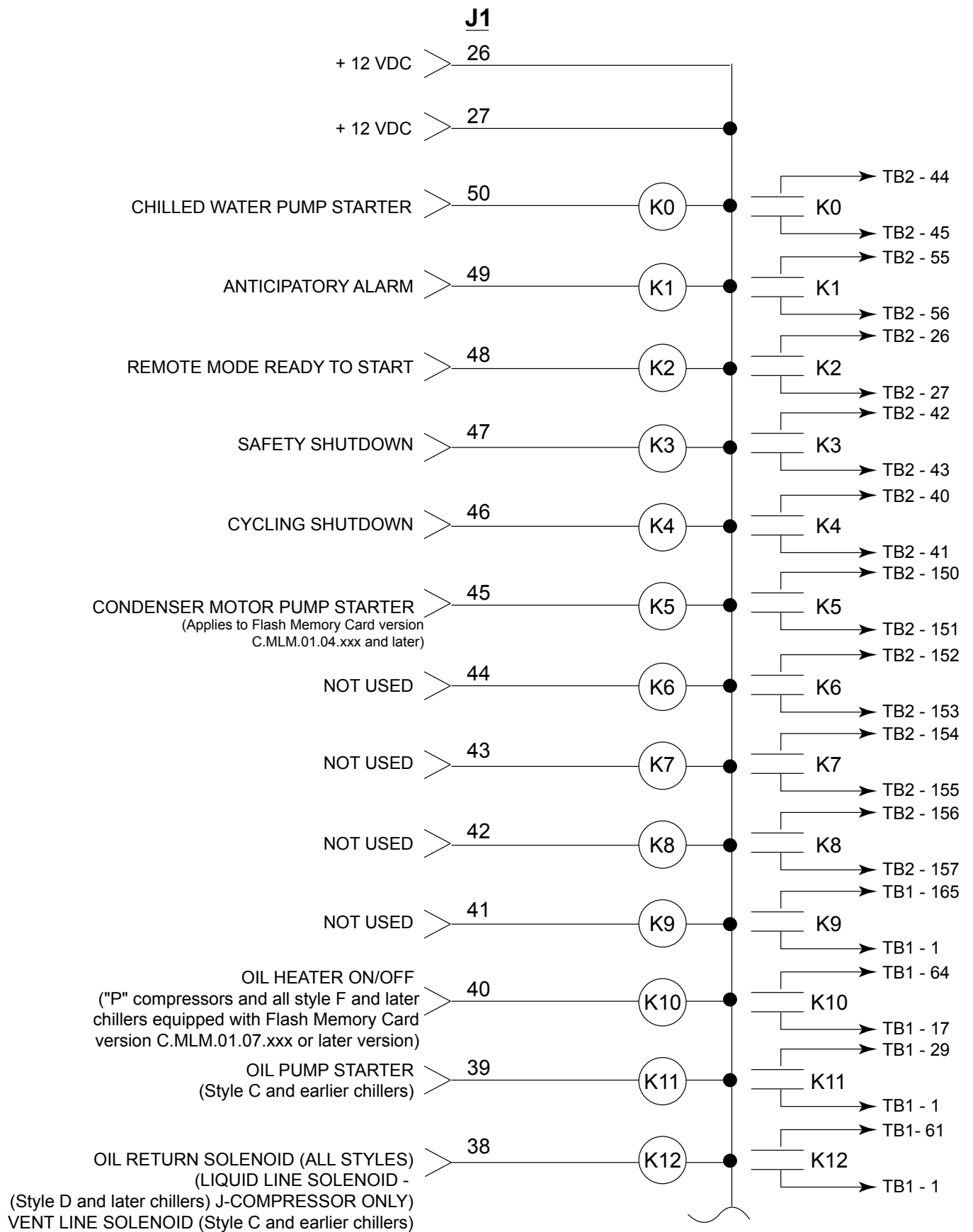
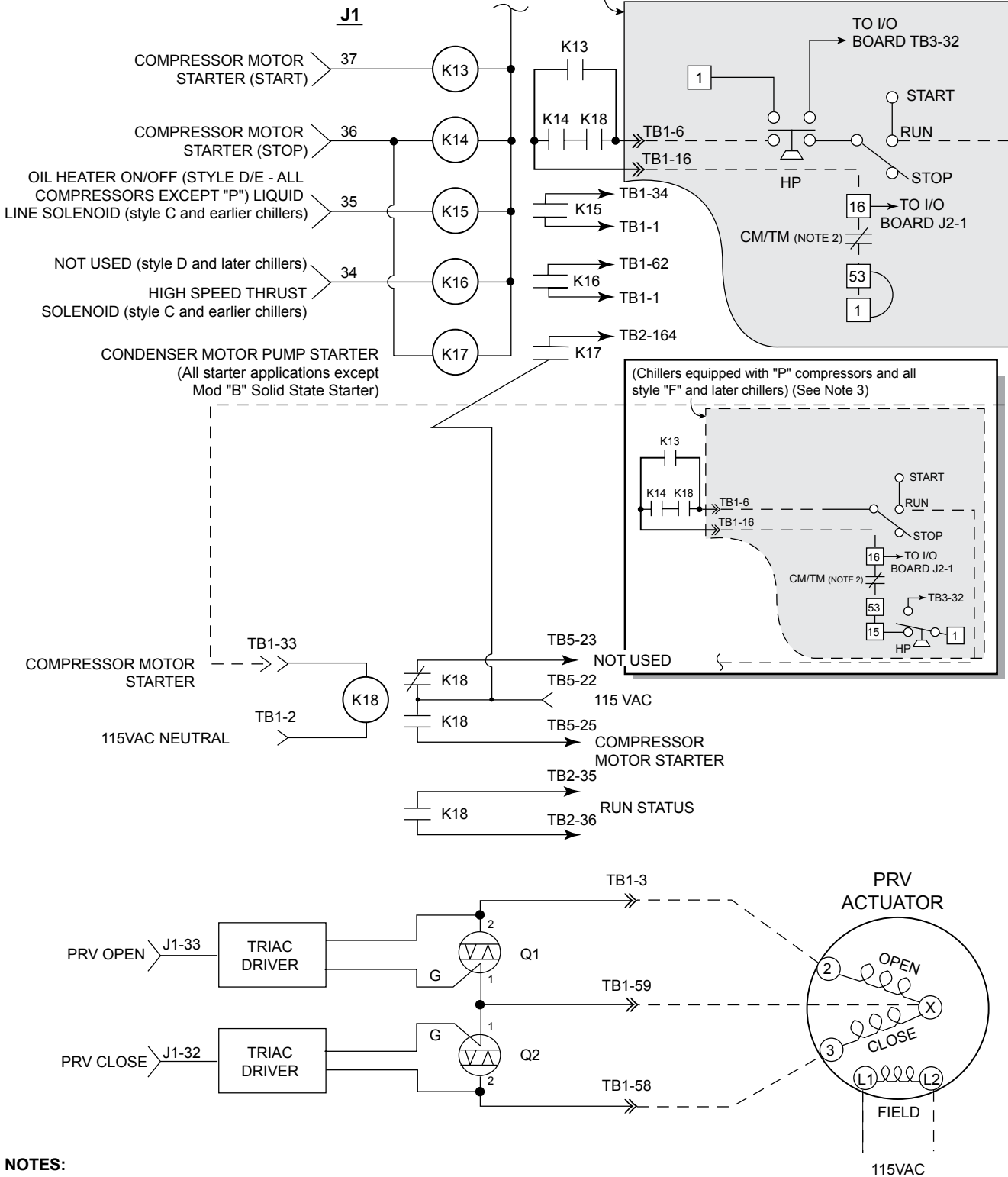

FIG. 17 – I/O BOARD DIGITAL OUTPUTS

LD09042

(Not applicable to "P" compressors or style F and later chillers)(See Note 3)
(See inset below for all others)



NOTES:

1. ----- indicates wiring external to I/O Board.
2. "CM" – Contacts of Relay K1 on Current Module (EM Starter Applications) or Solid State Starter Logic Board (Solid State Starter Applications) or VSD Logic Board (Compressor Motor Variable Speed Drive Applications).
3. Chillers equipped with "P" compressors and all style "F" and later chillers use a different High Pressure (HP) Switch and associated interface than other compressor applications.

LD09043

FIG. 17 (CONT'D) – I/O BOARD DIGITAL OUTPUTS

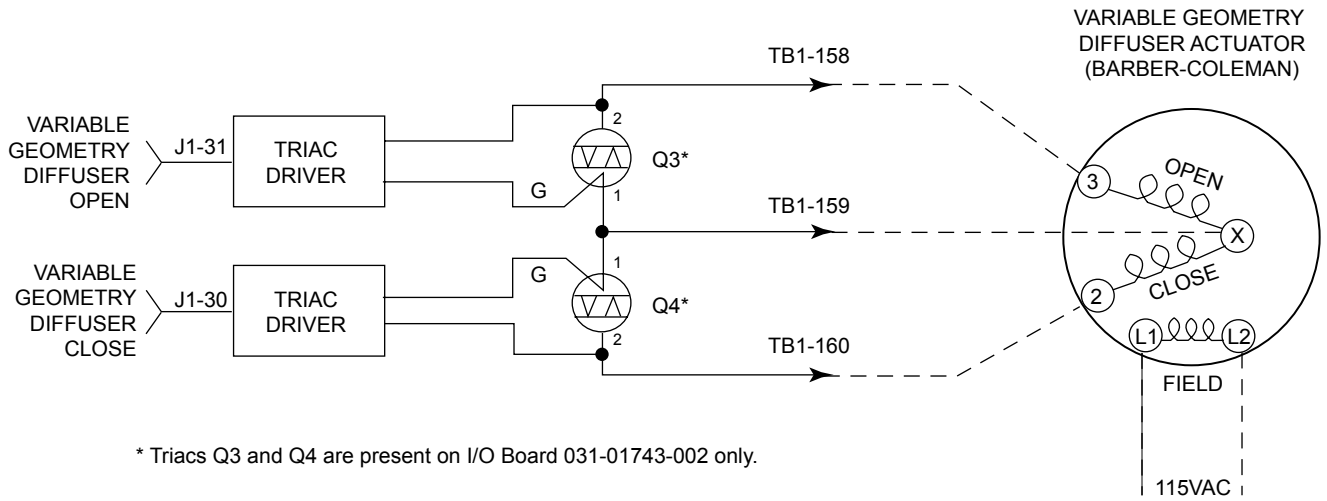

* Triacs Q3 and Q4 are present on I/O Board 031-01743-002 only.

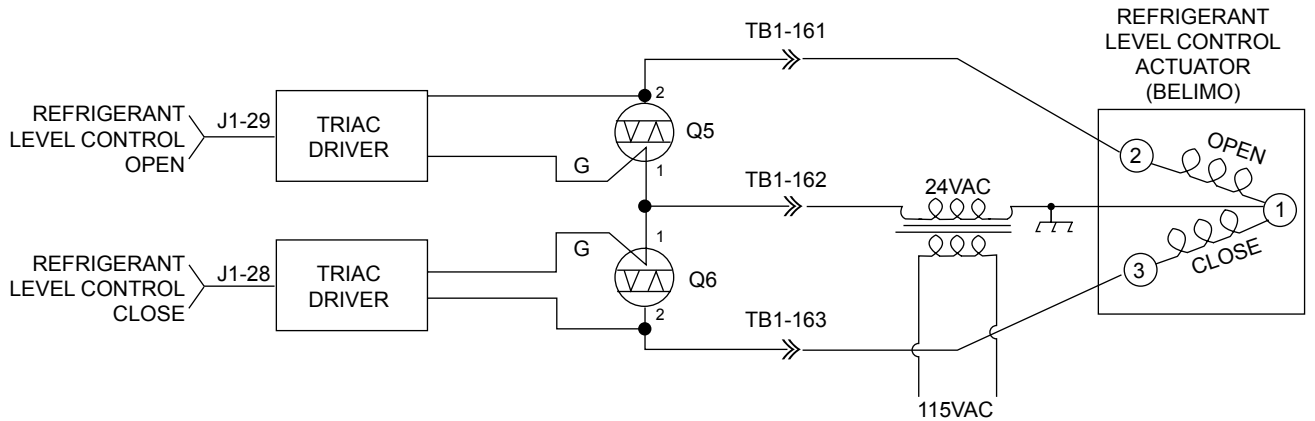
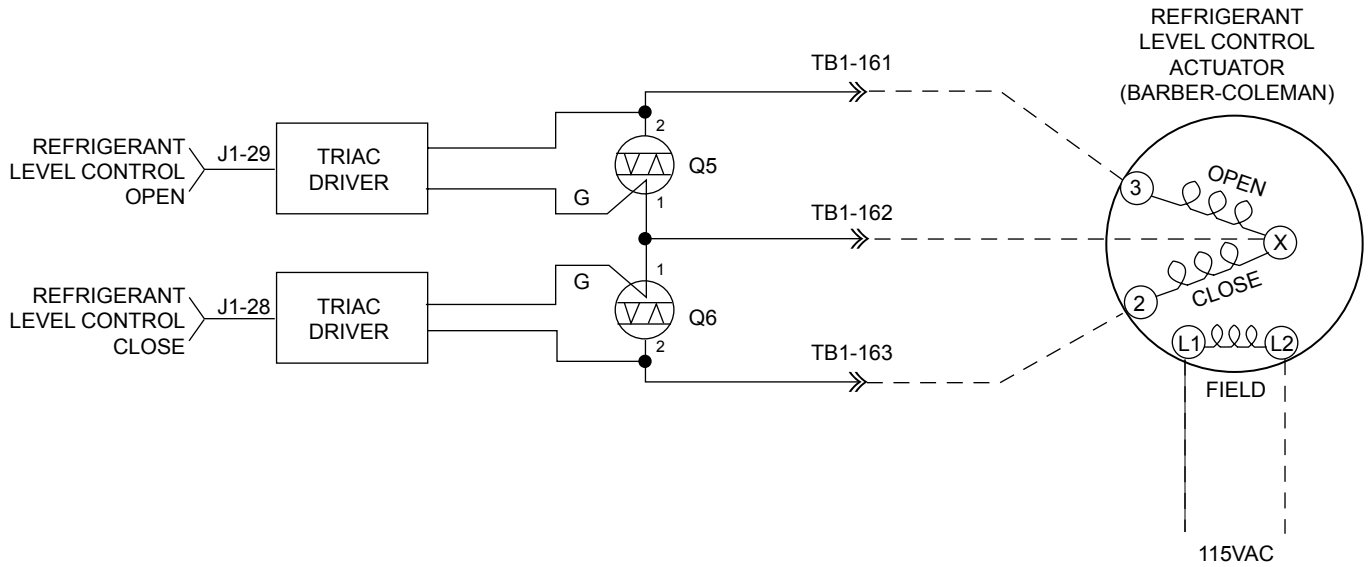

LD09567

FIG. 17 (CONT'D) – I/O BOARD DIGITAL OUTPUTS

SECTION 5

LIQUID CRYSTAL DISPLAY

(REFER TO FIG. 18 - 27)

A 10.4 inch color **Liquid Crystal Display**, along with supporting components **Display Interface Board** and **Backlight Inverter Board** are mounted on a plate that is attached to the OptiView Control Center door. A clear plexiglass faceplate prevents display surface damage. System operating parameters are displayed on various color graphic screens. The various display screens are selected for display using the Keypad keys.

The Display provided in the new chiller or from YORK as a service replacement part, could be manufactured by any of several approved manufacturers. Each Display requires a specific Display Interface Board, Backlight Inverter Board, Inverter Board interface cable and Program command set. **Therefore, Service replacement Displays or supporting components cannot be arbitrarily selected!!!** As explained below, replacement Displays are provided from YORK as kits to assure compatibility of all components. **Non-compatibility of components will result in incorrect operation!!!** Refer to "Display Interface Board" and "Backlight Inverter Board" sections that follow this section. Displays that could be provided from YORK in new chillers or as replacement parts are:

- SHARP LQ104V1DG61 (031-02886-000)
- SHARP LQ10D367/368 (031-01774-000)
- LG SEMICON LP104V2-W (031-02046-000)

The YORK part numbers of the Display Interface Board, Backlight Inverter Board and Inverter ribbon cable provided, are listed on a label attached to the Display mounting plate. These are the part numbers of the supporting components that are compatible with the installed display. These supporting components can be individually replaced. However, if the Liquid Crystal Display fails, Display replacement kit 331-01771-000 must be ordered as detailed below. This kit contains a replacement Display and all compatible supporting components.

The Display has 307,200 pixels arranged in a 640 columns X 480 rows matrix configuration. Each pixel consists of 3 windows; red, green and blue, through which a variable amount of light from the Display Backlight is permitted to pass through the front of the display. Imbedded in each window of the pixel is a transistor, the conduction of which determines the amount of light

that will pass through the window. The conduction of each transistor is controlled by a signal from the Display Controller on the Microboard. The overall pixel color is a result of the gradient of red, green and blue light allowed to pass.

Under Program control, the Display Controller on the Microboard sends a drive signal for each pixel to create the image on the display. Each pixel's drive signal is an 18 bit binary word; 6 bits for each of the 3 colors, red green and blue. The greater the binary value, the greater the amount of light permitted to pass. The columns of pixels are driven from left to right and the rows are driven top to bottom. To coordinate the drive signals and assure the columns are driven from left to right and the rows are driven from top to bottom, each drive signal contains a horizontal and vertical sync signal. The **Display Interface Board** receives these display drive signals from the Microboard J5 and applies them to the Display at connector J1. Refer to FIG. 28.

Although there are variations in control signal timing between different display manufacturers, FIG. 23 depicts typical control signals. Since these control signals occur at rates greater than can be read with a Voltmeter, the following description is for information only. There are 480 horizontal rows of pixels. Each row contains 640 3-window pixels. Beginning with the top row, the drive signals are applied within each row, sequentially left to right, beginning with the left most pixel and ending with the right most pixel. The rows are driven from top to bottom. The Vertical Sync (VSYNC) pulse starts the scan in the upper left corner. The first Horizontal Sync (HSYNC) pulse initiates the sequential application of RGB drive signals to the 640 pixels in row 1. Upon receipt of the **ENABLE** signal, an RGB drive signal is applied to the first pixel. As long as the **ENABLE** signal is present, RGB drive signals are then applied to the remaining 639 pixels at the CLK rate of 25.18M Hz, or one every 39.72 nanoseconds. Typically it takes 31 microseconds to address all 640 pixels. Similarly, the next HSYNC pulse applies drive signals to row 2. This continues until all 480 rows have been addressed. Total elapsed time to address all 480 rows is approximately 16 milliseconds. The next VSYNC pulse causes the above cycle to repeat. Displays can be operated in **FIXED** mode or **DISPLAY ENABLE** mode. In **FIXED** mode, the first pixel drive signal is applied a fixed number (48) of clock (CLK) cycles from the end of the HSYNC

pulse and the drive signals are terminated a fixed number (16) of CLK cycles prior to the next HSYNC pulse. In **DISPLAY ENABLE** mode, the pixel drive signals are applied to the pixels only while **ENABLE** signal is present. This signal is typically present 4-48 CLKS after the end of the HSYNC pulse and 2-16 CLKS prior to the next HSYNC pulse. All YORK applications operate in the **DISPLAY ENABLE** mode. The state of the **ENABLE** (Display Interface Board J1-27) signal from the Microboard places the Display in the desired mode as follows:

- SHARP LQ10D367/368 (031-01774-000) & LQ104V1DG61 (031-02886-000) Displays - When **ENABLE** maintained “low”, display operates in fixed mode.
- LG SEMICON Display (031-02046-000) does not have the fixed mode feature.

As described above, in OptiView Control Center applications, the Display scan is left to right, beginning with the top row and continuing sequentially through the rows to the last row. However, in Display applications other than OptiView Control Centers, image reversal is sometimes required. In image reversal applications, the scan is reversed; the scan is right to left, beginning with the last row and proceeding to the top row. The scan mode is determined by the configuration of wire jumpers on the Display Interface Board (refer to Section 6).

Displays by different manufacturers can require different timing and control signals. The Microboard must know which Display is present in order provide the correct signals. Therefore, when AC control power is first applied to the OptiView Control Center, as part of the power-up sequence, the Microboard reads the Panel ID wire jumpers P1D0 - P1D3 on the **Display Interface Board** and determines which Display is present. It can then provide the correct timing and control signals to produce the graphic image, as required by the Display manufacturer. Since the **Display Interface Board** identifies the Display for the Microboard, there is a different **Display Interface Board** required for each Display application and each has a unique jumper configuration that identifies the Display. A complete explanation of this process is included in the preceding “Microboard” section and the “Display Interface Board” section that follows.

The DC power source to operate the Display is provided by the Microboard J5. Some Display manufacturers require +5VDC; others require +3.3VDC. The position of Microboard Program Jumper JP2 determines which of these power sources is supplied to the Display. JP2 must be positioned according to the Display manufacturers requirements. Refer to Table 1, “Program Jumpers”.

The **Backlight Lamp** provides the illumination for the display. Average lamp life is 25000 hours (2.9 years). Some displays use one lamp. Others use two lamps. Lamps are replaceable, but not interchangeable between different displays. Each Display manufacturer specifies the required lamp for their display. Refer to replacement parts list for appropriate replacement lamp. Service replacement lamps are stocked in the YORK Service Parts Distribution Center. The lamp is illuminated by applying a high voltage AC (500 to 1500VAC) to it. This illumination voltage is created from a low level DC voltage (+12VDC or +5VDC as required by the Display manufacturer) by the **Backlight Inverter Board**. Lamp brightness is controlled by varying the high voltage AC. The greater the voltage the brighter the illumination. The lamp is controlled by on/off commands and brightness control signals applied to the **Backlight Inverter Board** from the Microboard. The Microboard Program determines when the lamp is turned on and off and the lamp brightness. Each Display manufacturer specifies the **Backlight Inverter Board** to be used. Therefore, it will vary according to the Display manufacturer. The ribbon cable that connects the Microboard to the Backlight Inverter Board also varies according to the Display manufacturer’s requirements. Refer to FIG. 29 to 31. Microboard Program Jumpers JP3, 4, 5, 7 and 8 determine the voltage levels of the control signals sent to the **Backlight Inverter Board** and must be configured per the Display manufacturer’s requirements as listed in Table 1. A detailed description of the operation of this board is in the “Backlight Inverter Board” section that follows. Also refer to the preceding “Microboard” section for a detailed description of the **Lamp Dimmer** circuit.

The actual Display that is installed in the OptiView Control Center of the new chiller is determined by the Display manufacturer contractual agreement in place during the time of OptiView Control Center production. Displays stocked for Service replacement are a result of that same agreement. Therefore, the Display received for service replacement may be by a different manufacturer than the one in the OptiView Control Center. Since each Display manufacturer requires a specific Display Interface Board, Backlight Inverter Board and Inverter

Ribbon Cable, replacement Displays are ordered and supplied as a Display Replacement Kit (YORK Part Number 331-01771-000) to assure component compatibility. The items supplied in the kit are compatible with the supplied Display. The kit consists of the following items mounted on a Display mounting plate:

Display Replacement Kit 331-01771-000:

1. Liquid Crystal Display with Lamp
2. Appropriate Display Interface Board for item 1
3. Appropriate Backlight Inverter Board for item 1
4. Appropriate ribbon cable (Backlight Inverter Board to Microboard) for item 1
5. Ribbon cable (Display Interface Board to Microboard)
6. All mounting hardware
7. Installation instructions. A label attached to the Display mounting plate lists the YORK part numbers of the Display supporting components mounted on the Display mounting plate and the required Microboard Program Jumper (JP2 through 8) configurations. **Microboard Program Jumpers JP2-JP8 will have to be configured appropriately for the replacement display.**

Display Handling:

1. The display is made of glass. It could break if dropped.
2. The display front surface is easily scratched. If soiled, wipe with a dry cotton cloth. Use no water or chemicals.
3. The display is static sensitive. Electrostatic discharges may damage the display.
4. A laminated film is adhered to the display front glass surface to prevent it from being scratched. Peel off very slowly to prevent static damage.



Always remove control power from the OptiView control center before connecting or disconnecting wires to the display. Connecting or disconnecting wires to the display with power applied will damage the display!!!

BACKLIGHT LAMP REPLACEMENT

SHARP LQ10D367/368 (031-01774-000) Display: (Refer to FIG. 24)

Removal:

The Lamp slides into the Display from left to right and is secured with a locking tab.

1. Remove Control Power from the OptiView Control Center.
2. Remove protective cover from rear of Display.
3. Disconnect Lamp AC power connector from Backlight Inverter Board.
4. Using fingernail or thin flat blade screwdriver, bend the locking tab outward slightly to clear the Lamp housing protrusion.
5. Grasp Lamp AC power connector and gently pull until Lamp housing clears locking tab.
6. Grasp Lamp housing and pull until Lamp housing is completely removed from the Display.

Installation:

1. Slide new Lamp into Display from left to right until Lamp housing protrusion locks into Display locking tab.
2. Connect Lamp AC power connector to Backlight Inverter Board.
3. Apply Control Power to OptiView Control Center.

**LG Semicon LP104V2-W (031-02046-000) &
SHARP LQ104V1DG61 (031-02886-000)
Display (refer to FIG. 25)**

Removal:

The Lamp slides into the Display from left to right and is secured with a screw.

1. Remove Control Power from the OptiView Control Center.
2. Remove protective cover from rear of Display.
3. Disconnect Lamp AC power connector from Backlight Inverter Board.
4. Using small Phillips screwdriver, remove lamp retaining screw.
5. Grasp Lamp AC power connector and gently pull until Lamp housing is completely removed from the Display.

Installation:

1. Slide new Lamp into Display from left to right until Lamp housing is fully inserted.
2. Secure Lamp with Lamp retaining screw.
3. Connect Lamp AC power connector to Backlight Inverter Board.
4. Apply AC power to OptiView Control Center.

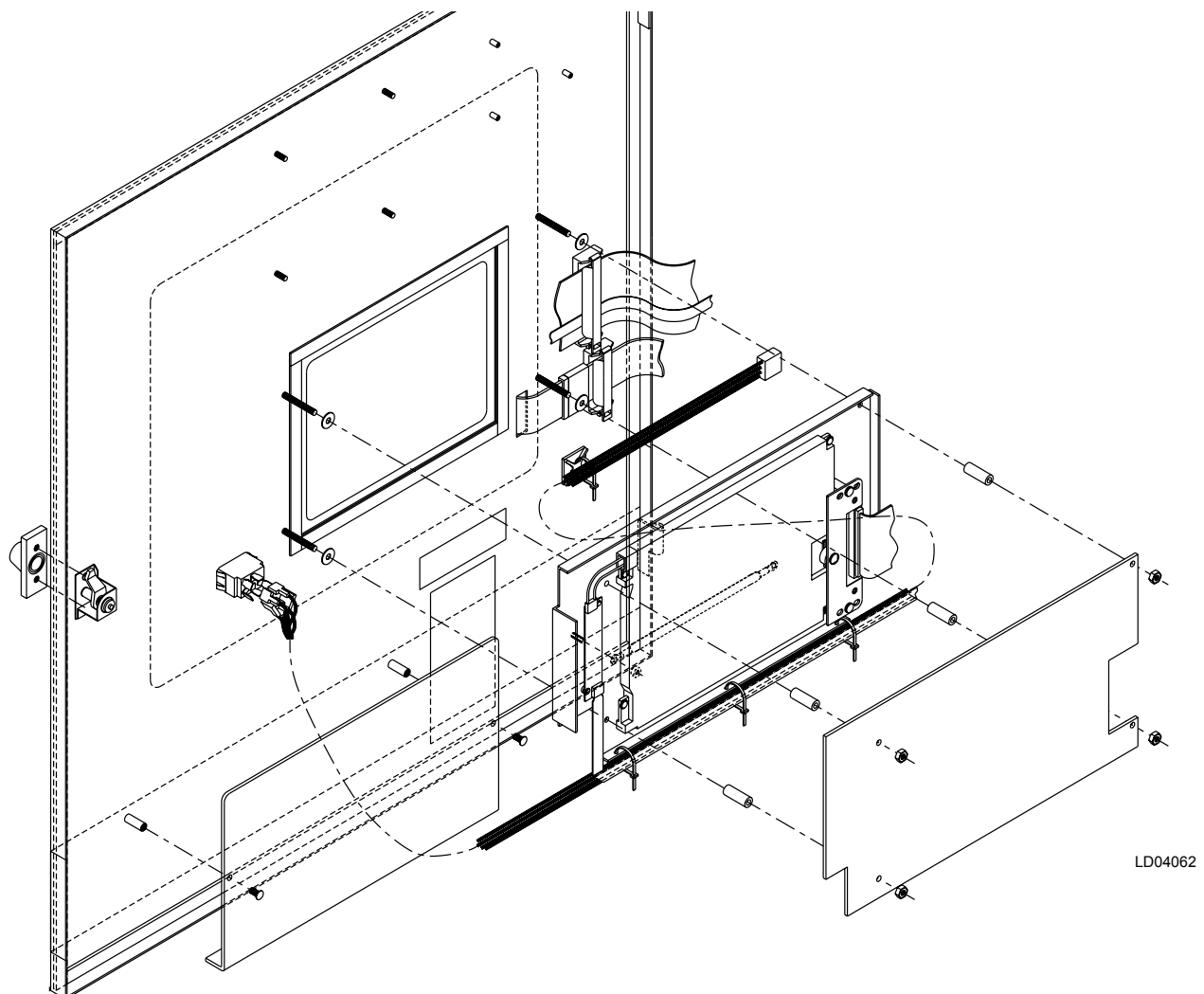

LD04062

FIG. 18 – DISPLAY, MOUNTING

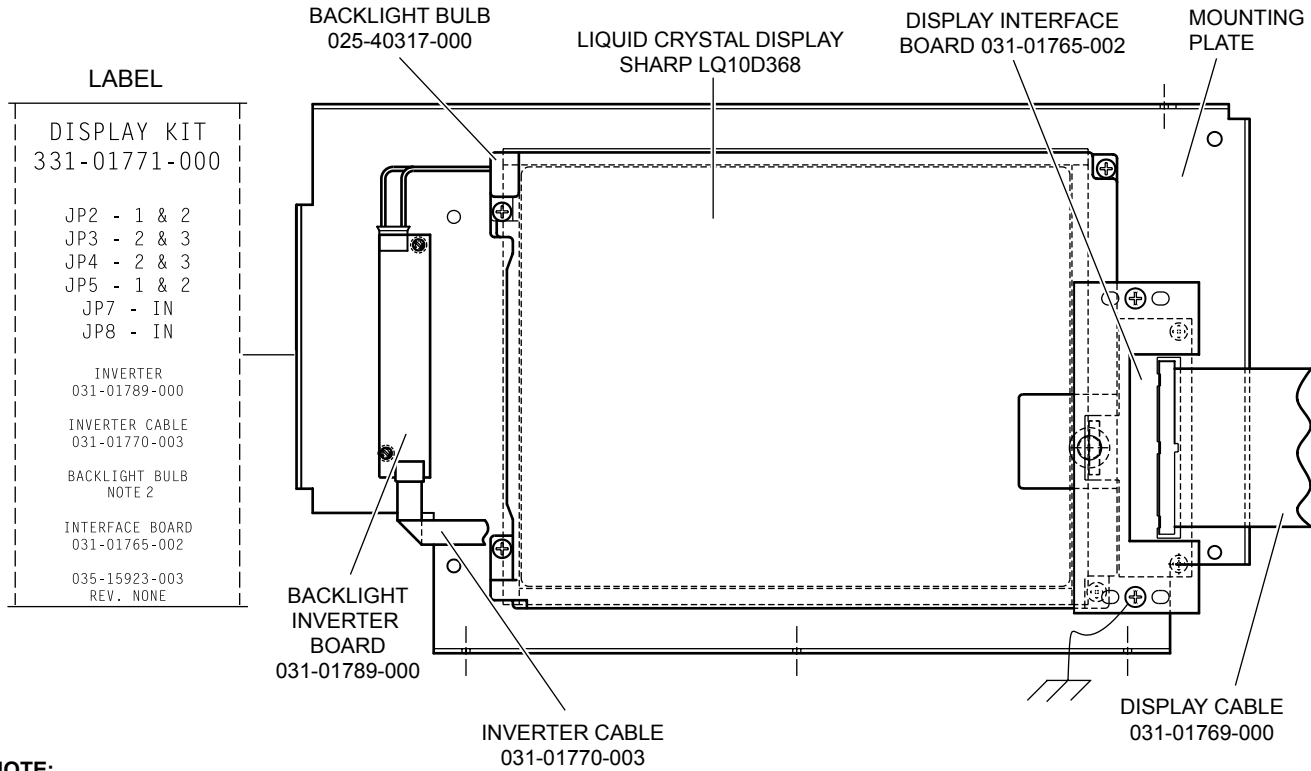

NOTE:

1. Configure Microboard Program Jumpers per label.
2. 025-33752-000 (prior to October 2002)
- 025-40317-000 (after October 2002)

LD05526b

FIG. 19 – LIQUID CRYSTAL DISPLAY ASSEMBLY – SHARP LQ10D367/368 (031-01774-000) DISPLAY

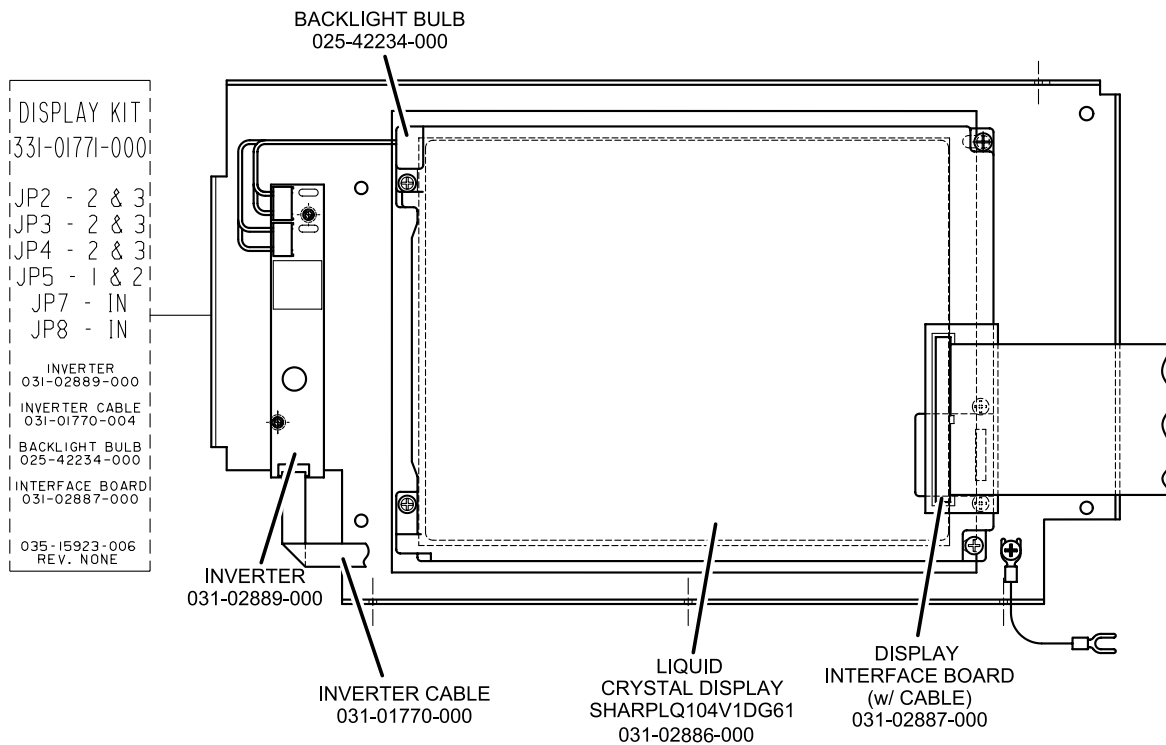

NOTE:

1. Configure Microboard Program Jumpers per label.

LD14074

FIG. 20 – LIQUID CRYSTAL DISPLAY ASSEMBLY – SHARP LQ104V1DG61 (031-02886-000) DISPLAY

NOT AVAILABLE AT THIS TIME

FIG. 21 – LIQUID CRYSTAL DISPLAY ASSEMBLY – NOT AVAILABLE

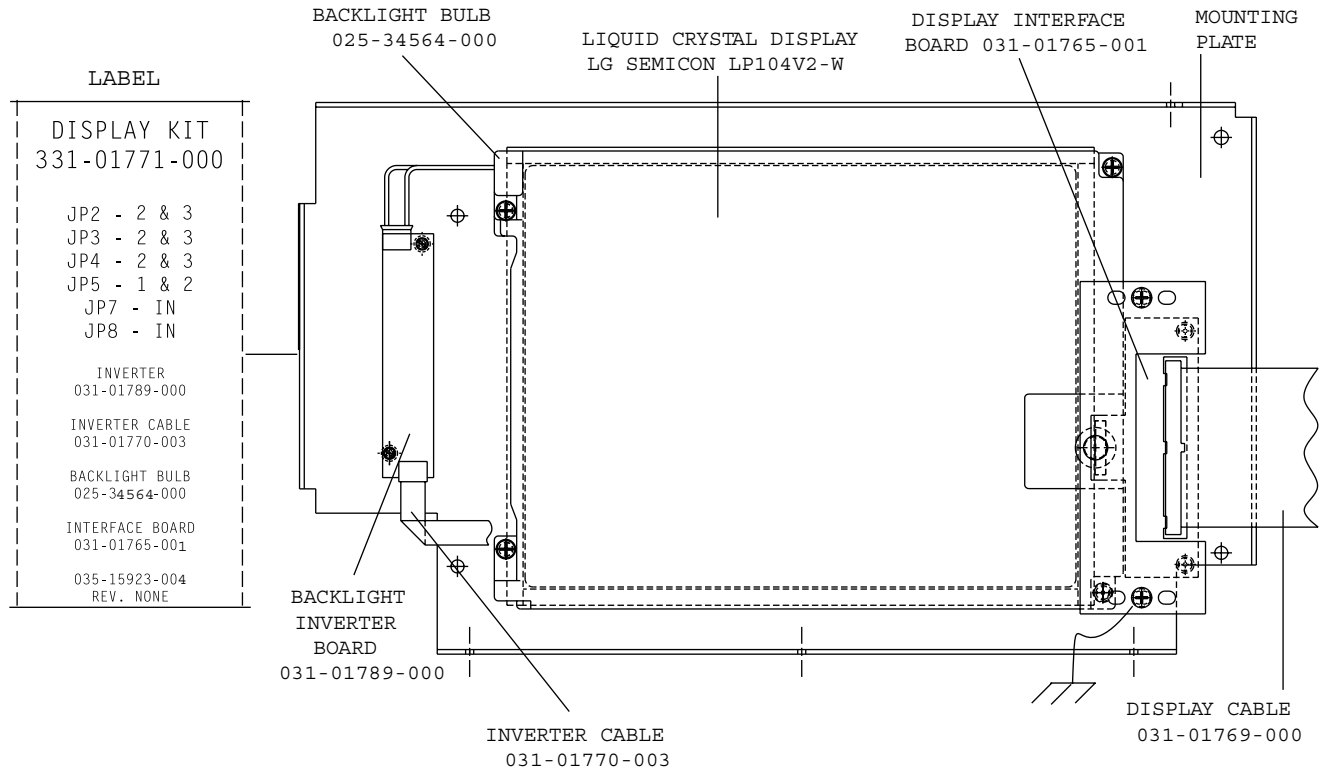

LD05525

NOTE:

1. Configure Microboard Program Jumpers per label.

FIG. 22 – LIQUID CRYSTAL DISPLAY ASSEMBLY - LG SEMICON LP104V2-W (031-02046-000)

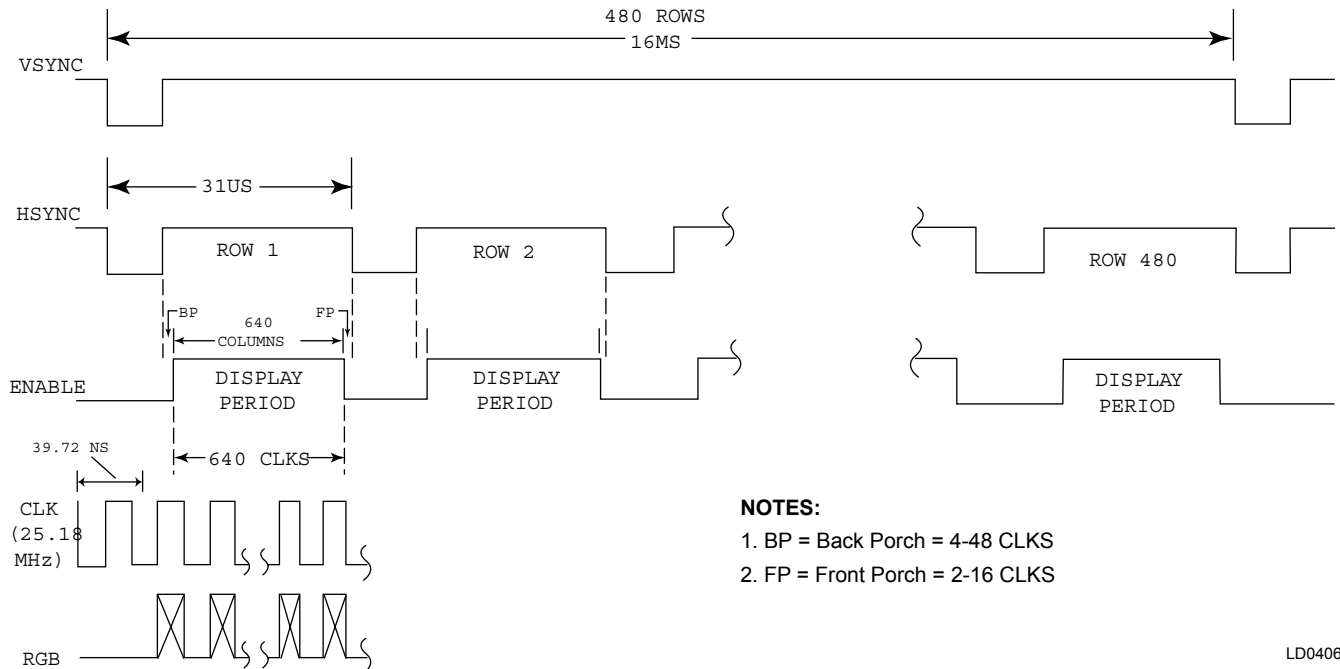

NOTES:

1. BP = Back Porch = 4-48 CLKS
2. FP = Front Porch = 2-16 CLKS

LD04066

FIG. 23 – LIQUID CRYSTAL DISPLAY TYPICAL CONTROL SIGNAL TIMING

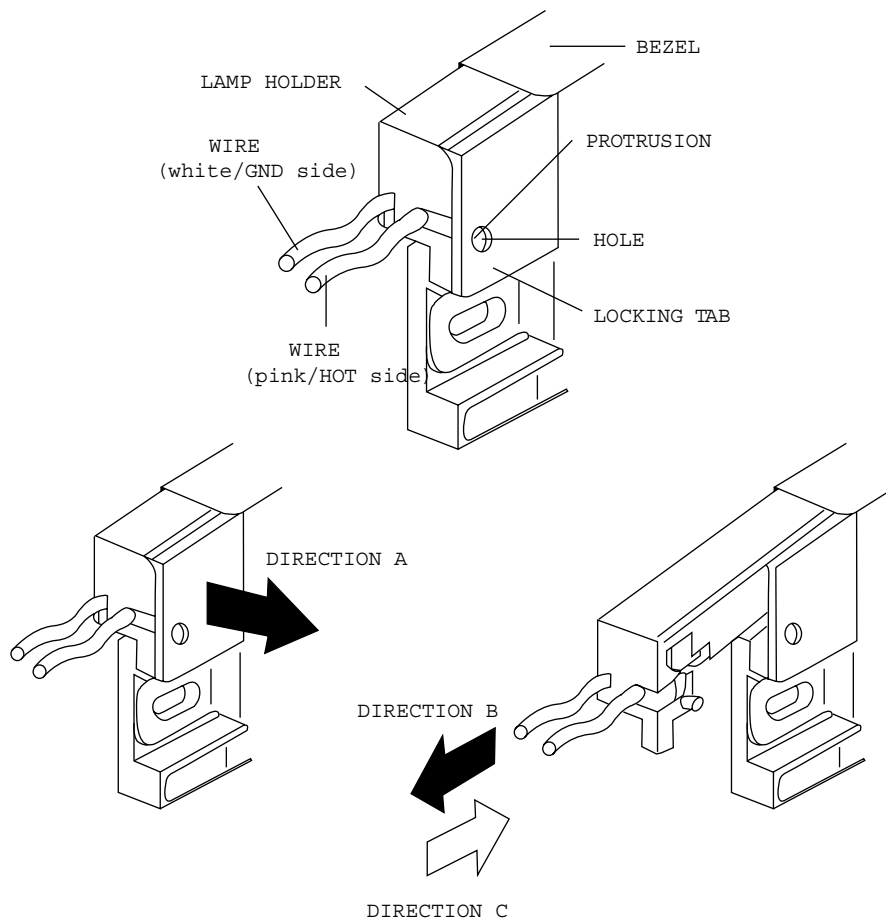

5

LD04067

FIG. 24 – DISPLAY (SHARP LQ10D367/368) LAMP REPLACEMENT

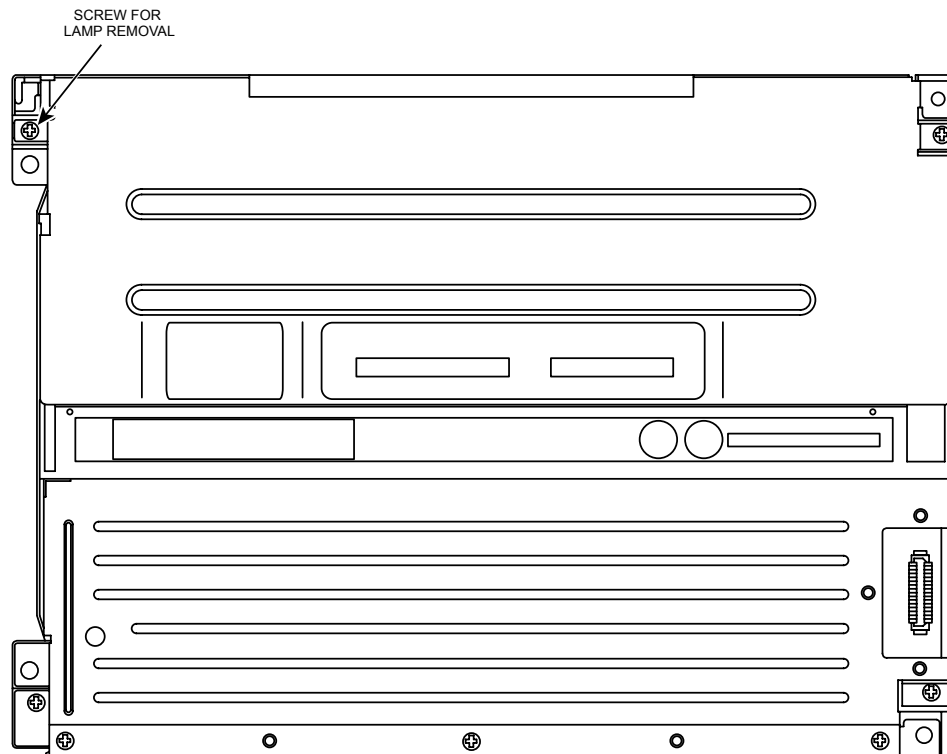

LD14075

FIG. 25 – DISPLAY (SHARP LQ104V1DG61 (031-02886-000) AND LG LP104V2-W (031-02046-000))

NOT AVAILABLE AT THIS TIME

FIG. 26 – NOT AVAILABLE

NOT AVAILABLE AT THIS TIME

FIG. 27 – NOT AVAILABLE

SECTION 6

DISPLAY INTERFACE BOARD

(REFER TO FIG. 28 & 28A)

The Display Interface Board is located on the Liquid Crystal Display and is part of the Microboard interface to the Display. It permits the use of Displays by different manufacturers, by providing the Microboard with a means of automatically determining which Display is present.

Since different display manufacturers require different timing and control signals, the Microboard Display Controller must be configured to meet the requirements of the actual display installed. When AC power is applied to the Optiview Control center, the Microboard reads the Panel Identification (PID0 thru PID3) voltage levels on the Display Interface Board during the power-up sequence to determine which display is present. These voltage levels indicate the actual display installed and the Display Controller is automatically configured appropriately. To provide the appropriate Panel ID voltage levels for the different displays, there are different Display Interface Boards. These boards have permanent wire jumpers that provide the voltage levels to the microboard for Panel ID signals (PID0 thru PID3). These jumpers connect these signals to either ground or open-circuit. When connected to ground, the voltage level for that signal is 0vdc. When open, the voltage level is the VCC logic level, which is either 3.3vdc or 5.0vdc, depending on the display (refer to Microboard Program Jumper JP2).

The following are the different Display Interface Boards and the Panel ID signals they provide to the Microboard:

Display Interface Board 031-01765-001
 Display Applicability:
 LG Semicon LP104V2-W (031-02046-000)

- PID0 – IN (GND)
- PID1 – OUT (VCC)
- PID2 – OUT (VCC)
- PID3 – OUT (VCC)

Display Interface Board 031-01765-002
 Display Applicability:
 SHARP LQ10D367/368 (031-01774-000)

- PID0 – OUT (VCC)
- PID1 – IN (GND)
- PID2 – OUT (VCC)
- PID3 – OUT (VCC)

Display Interface Board 031-02887-000
 Display Applicability:
 SHARP LQ104V1DG61 (031-02886-000)

- PID0 – OUT (VCC)
- PID1 – IN (pin 45 is tied to 44) (GND)

PID2 – No Connection Open (VCC)
 PID3 – No Connection Open (VCC)

The Displays can operate in either NORMAL or REVERSE mode for the Right/left (R/L) and Up/Down (U/D) scan. Normal for the R/L scan is left to right. Normal for the U/D scan is top to bottom. As used in the Optiview Control Center, it is configured to operate in Normal mode for both of these scans. The Reverse mode for R/L is right to left. Reverse mode for U/D is bottom to top. The Display Interface Board provides the appropriate signals to the display to put it in Normal scan mode. By hardwired jumper or wiring configuration, the signal is either tied to ground, VCC (+3.3vdc or +5vdc, as determined by Microboard Program Jumper JP2) or left open as follows:

Display Interface Board 031-01765-001
 Display Applicability:
 LG Semicon LP104V2-W (031-02046-000)

- P30 – OUT (Open)
- P31 – OUT (Open)

Display Interface Board 031-01765-002
 Display Applicability:
 SHARP LQ10D367/368 (031-01774-000)

- P30 – IN (VCC)
- P31 – IN (GND)

Display Interface Board 031-02887-000
 Display Applicability:
 SHARP LQ104V1DG61 (031-02886-000)

- J1-30 – (VCC)
- J1-31 – (GND)

Display Interface Boards are available individually for service replacement. The part number of the Display Interface Board for the installed display is listed on a label attached to the display mounting plate. The appropriate board is also supplied with display kit 331-01771-000.

The red, green and blue display drive and control signals are simply passed through the **Display Interface Board**. The value of VCC is either +5VDC or +3.3VDC, as determined by the position of Program Jumper JP2 on the microboard.

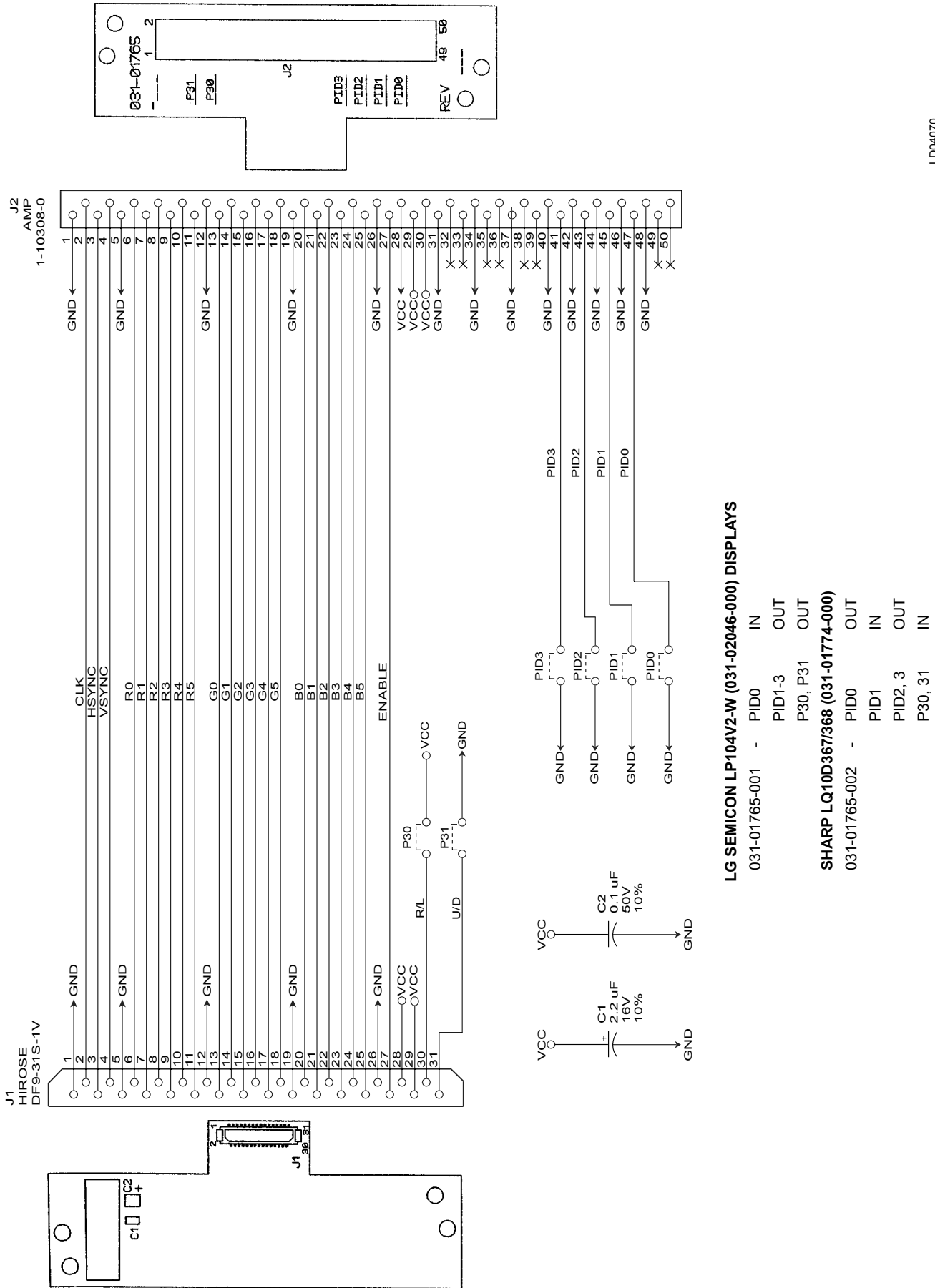

LD04070

FIG. 28 – DISPLAY INTERFACE BOARD 031-01765-001 AND 031-01765-002

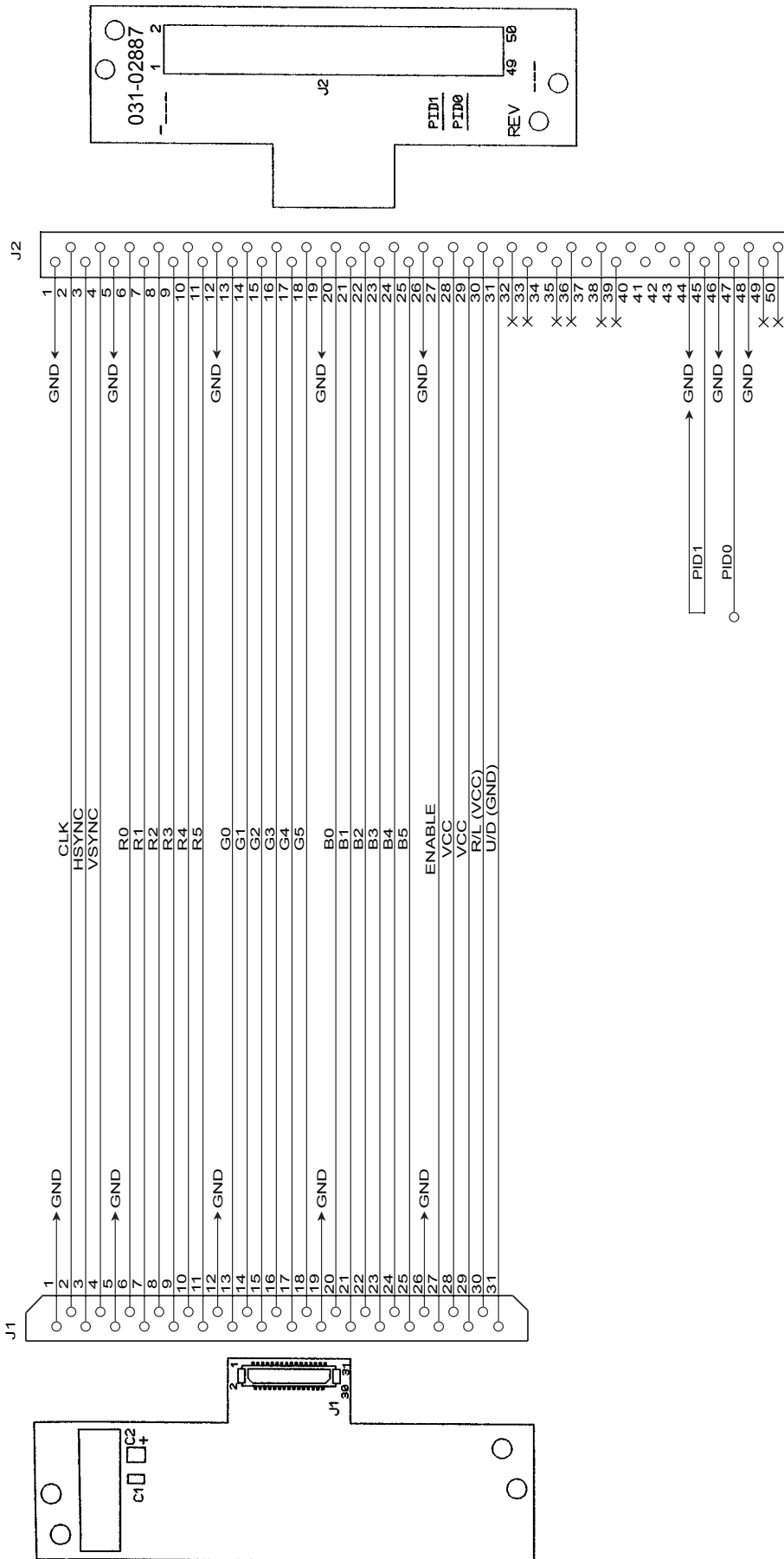

FIG. 29 – DISPLAY INTERFACE BOARD 031-02887-000

This page intentionally left blank.

SECTION 7

DISPLAY BACKLIGHT INVERTER BOARD

(REFER TO FIG. 29 - 31)

The **Display Backlight Inverter Board** generates a high voltage AC signal that is applied to the backlight lamp, causing it to illuminate. The magnitude of the signal determines the lamp brightness. Displays by some manufacturers have two lamps; one at the top and one at the bottom of the display. Other Display manufacturers have only a lamp at the top of the display.

An **Inverter** converts low level DC voltage (+12VDC or +5VDC, as required by the manufacturer) from the Microboard to a 500 to 1500VAC 60K Hz signal that is applied to the lamp. The higher the AC voltage, the greater the brightness of the lamp. When this voltage is not present, the lamp is turned off.



High voltage, up to 1500VAC, is present at the output of the backlight inverter board. Refer to FIGures 29 to 31 and locate the output connectors. Use extreme caution when working in this area!!!

Different Display manufacturers require different Backlight Inverter Boards. The different board designs require different control voltage inputs. To accommodate these variations, Microboard Program Jumpers JP3 - JP5, JP7 and JP8 must be configured to provide the required voltage levels. A label attached to the Display mounting plate lists the required Program Jumper configuration for that particular display. Refer to Table 1 for required Program Jumper configurations for the various Display applications.

Under Program control, the Microboard generates the control signals that are applied to the Backlight Inverter Board. The Program determines when the lamp is turned on and off. It also adjusts the lamp brightness. To increase the average lamp life of 25000 hours, the lamp brightness is normally adjusted to 50%. This brightness level will still allow the display to be visible. When the Program senses a Keypad key has been pressed, it adjusts the brightness to 100% (maximum).

The lamp illumination high voltage AC is generated from either +12VDC or +5VDC as required by the manufacturer. Microboard Program Jumper JP5 must be positioned to provide the required voltage. The Microboard provides the **Backlight Enable** signal. This signal turns the lamp on and off. Some manufacturers require this signal to be +12VDC, others require +5VDC. Program Jumper JP4 must be positioned to provide the required voltage. Further, some applications require this signal to be a +VDC (+12VDC or +5VDC) to turn on the lamp. Others require this signal to be 0VDC to turn on the lamp. Program Jumper JP3 must be positioned to provide the required polarity.

Depending upon the Display manufacturer, the brightness control input from the Microboard must be either a variable voltage or a variable resistance. Microboard Program Jumpers JP7 and JP8 are used to provide the appropriate technique (refer to FIG. 10). The lamp dimmer circuit on the Microboard is an IC that is the electrical equivalent of a 10K ohm potentiometer with 100 positions or steps. The Program adjusts the position of the potentiometer. When configured for variable voltage (JP7 & JP8 installed), the output between Microboard J6-7 and J6-8 is a 0 to +5.0VDC signal. Not all applications require the full 5.0VDC range. If configured for variable resistance (JP7 and JP8 removed), the output between Microboard J6-7 and J6-8 is a 0 to 10K ohm variable resistance.

The OptiView Control Center could be supplied with any of several approved Displays. Each Display requires a specific Backlight Inverter Board as specified below and in FIGures 29 to 31. These boards are individually available as service replacement parts (the required Backlight Inverter Board part number is listed on the label attached to the Display mounting plate). However, service replacement Displays are provided in a kit (YORK P/N 331-01771-000) that includes the appropriate Backlight Inverter Board (refer to “Liquid Crystal Display” Section).

SHARP model LQ10D367/368 (031-01774-000) AND LG Semicon LP104V2-W (031-02046-000) displays require a Backlight Inverter Board 031-01789-000 (ref. FIG. 29).

SHARP model LQ104V1DG61 display (031-02886-000) requires Backlight Inverter Board 031-02889-000 (ref Fig 30). These boards generate a lamp illumination high voltage AC from +12VDC. When the Backlight Enable signal is +5VDC, the high voltage signal is applied to the lamp. When the Enable is 0VDC, the high voltage is removed from the lamp.

The lamp brightness is controlled by a variable voltage signal, developed by the lamp dimmer circuit (ref fig 10A) on the Microboard and applied to the Inverter Board. The lamp dimmer circuit varies the voltage over the range of 0 to +3.0 VDC. 0VDC produces maximum brightness (100%). +3.0VDC produces minimum brightness (0%). Voltages between these values produce a linear brightness between 100% and 0%.

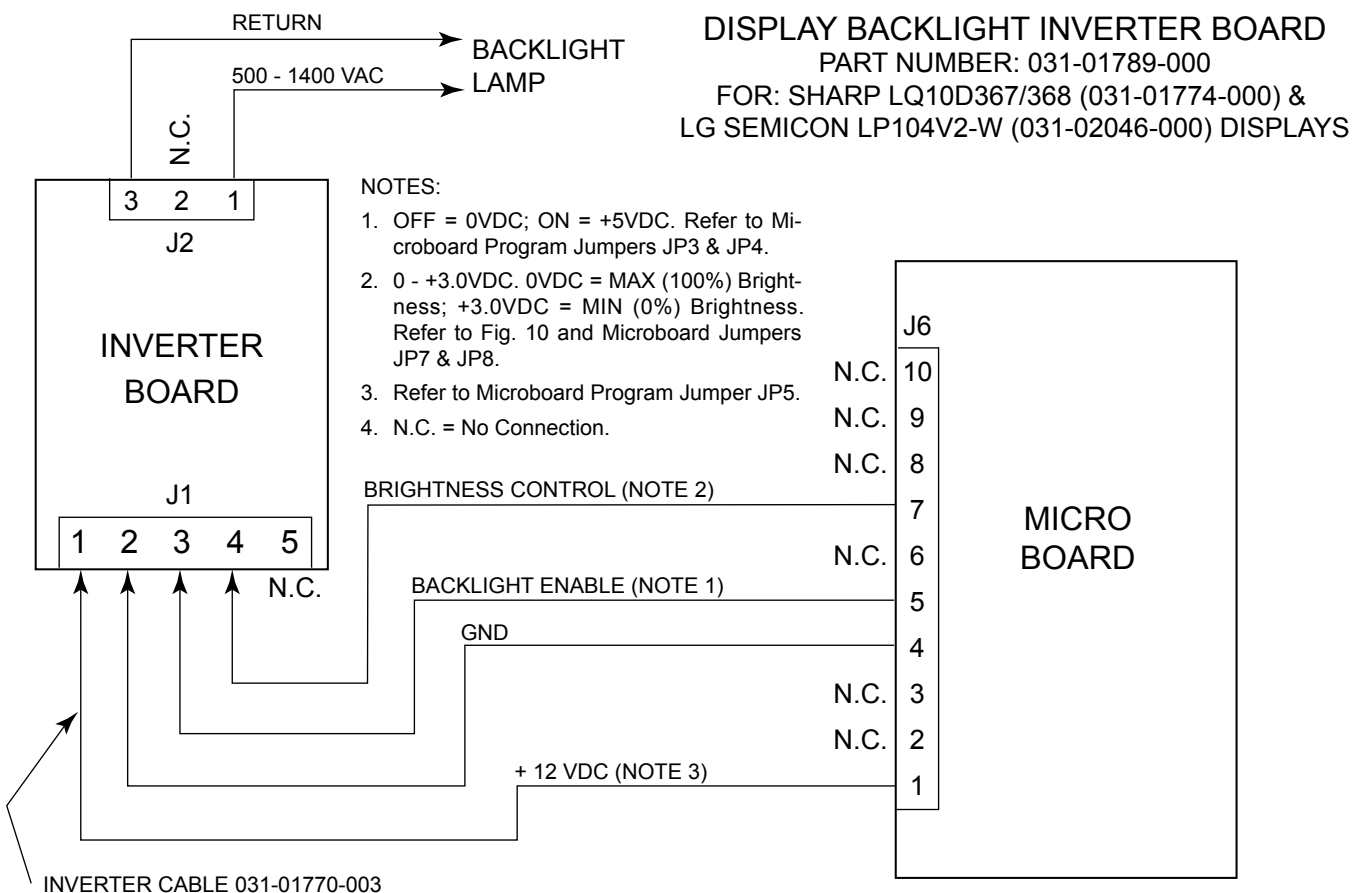
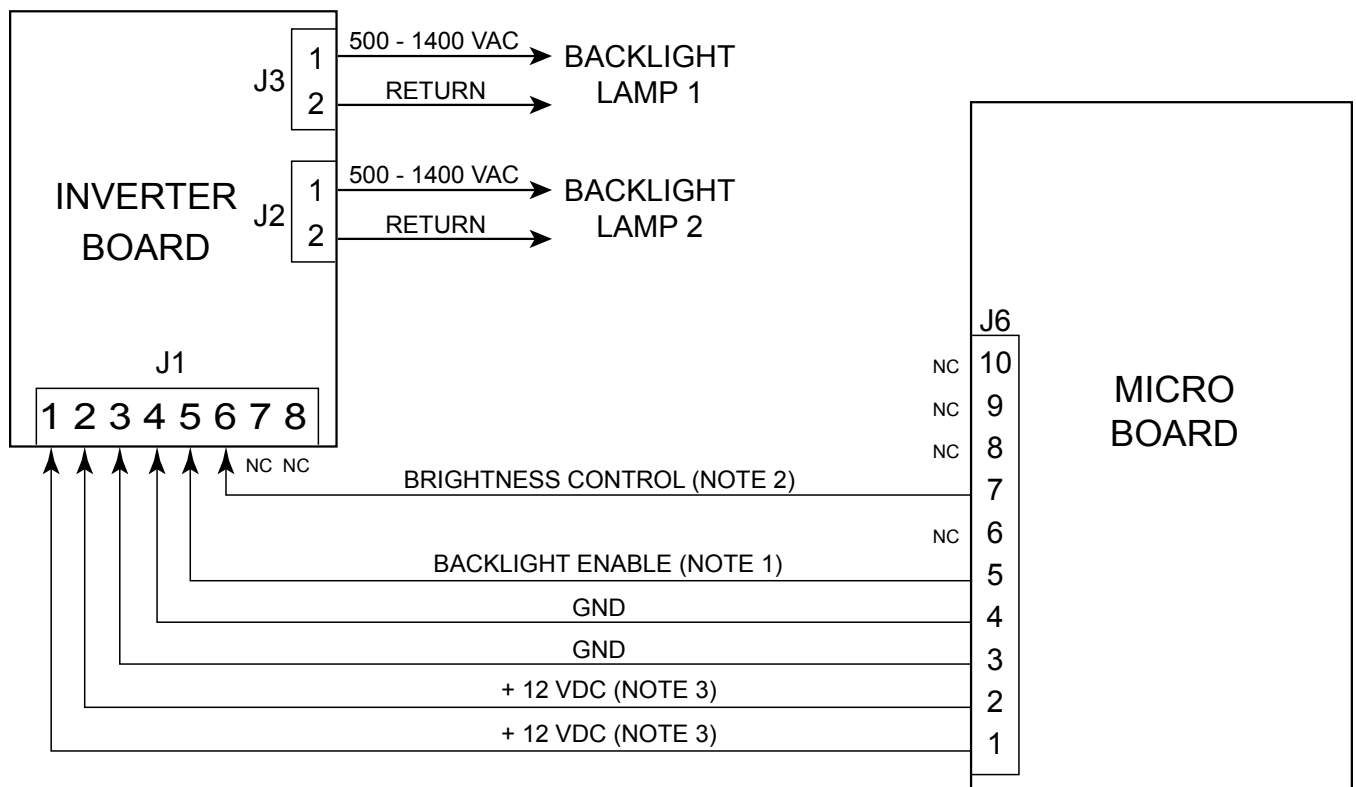

FIG. 30 – DISPLAY BACKLIGHT INVERTER BOARD (SHARP LQ10D367/368 (031-01774-000) & LG SEMICON LP104V2-W (031-02046-000))

DISPLAY BACKLIGHT INVERTER BOARD
 PART NUMBER: 031-02889-000
 FOR: SHARP LQ104V1DG6 (031-02886-000) DISPLAYS



NOTES:

1. OFF = 0VDC; ON = + 5VDC. Refer to Microboard Program Jumpers JP3 & JP4.
2. 0- + 3.0 VDC. 0VDC = MAX (100%) brightness. +3VDC = MIN (0%) brightness. Refer to Microboard Program Jumpers JP7 & JP8.
3. Refer to Microboard Program Jumper JP5.
4. N.C. = No Connection.

LD09568b

FIG. 31 – DISPLAY BACKLIGHT INVERTER BOARD - SHARP LQ104V1DG61 DISPLAY 031-02886-000

SECTION 8 KEYPAD

(REFER TO FIGURES 32 & 33)

The **Keypad** contains touch-sensitive keys that allow the Operator to interface with the OptiView Control Center. The Operator presses the keys to request the desired screens of information and enter System Setpoints.

The top layer of the Keypad contains embossed areas identifying the keys. Under each embossed key area are two conductors, one on top of the other, separated by an air space. The conductors are arranged in a matrix of rows and columns and connected to the Keypad connector as shown in FIG. 32. The embossed area of each key is located directly over the intersection point of the conductors. Pressing the embossed key area causes contact and electrical continuity between the two conductors. For example, pressing the “1” key creates continuity between the Keypad connector pin 5 (column 3) and pin 13 (row 4). Since this connector is interfaced to the Microboard (J18), the Microboard senses this continuity as described below and concludes the “1” key is pressed.

The Microboard Program continuously scans the Keypad to determine if a key is pressed. Beginning with row 1 and proceeding through all rows, the Program places a “logic low” (<1VDC) on a row, a “logic high” (>4VDC) on the remaining rows and reads the columns. A logic low in any column indicates a key in that column and row is pressed. For example, if at the time row 4

is being driven low, if column 3 is low, then the Micro concludes the key at coordinate of row 4 and column 3 is pressed. Since the coordinates of all keys are stored in the Microboard’s Program, it can identify which key is at this coordinate and responds accordingly. In this example the “1” key is pressed.

In order for the Microboard to reliably detect closed and open keys, each key must meet a closed circuit and open circuit resistance requirement. When a key is pressed, the contact resistance must be ≤ 100 Ohms. When a key is not pressed, the contact resistance must be ≥ 1 Meg Ohm. If the Microboard is not responding to a pressed key, or if it’s detecting a closed key when none are pressed, it could be because the contact resistance requirements are not being met. The operation of each key can be checked with an Ohmmeter. To check the open and closed contact resistance of any key, refer to the “Diagnostics and Troubleshooting” Section 23 of this book.

The Keypad is attached to the front of the OptiView Control Center door with an adhesive backing. If service replacement is required, start at one corner and slowly peel the Keypad from the door. The rear side of the replacement Keypad is coated with an adhesive covered with a paper backing. Remove the paper backing, align the Display and rocker switch openings and apply the Keypad to the door.

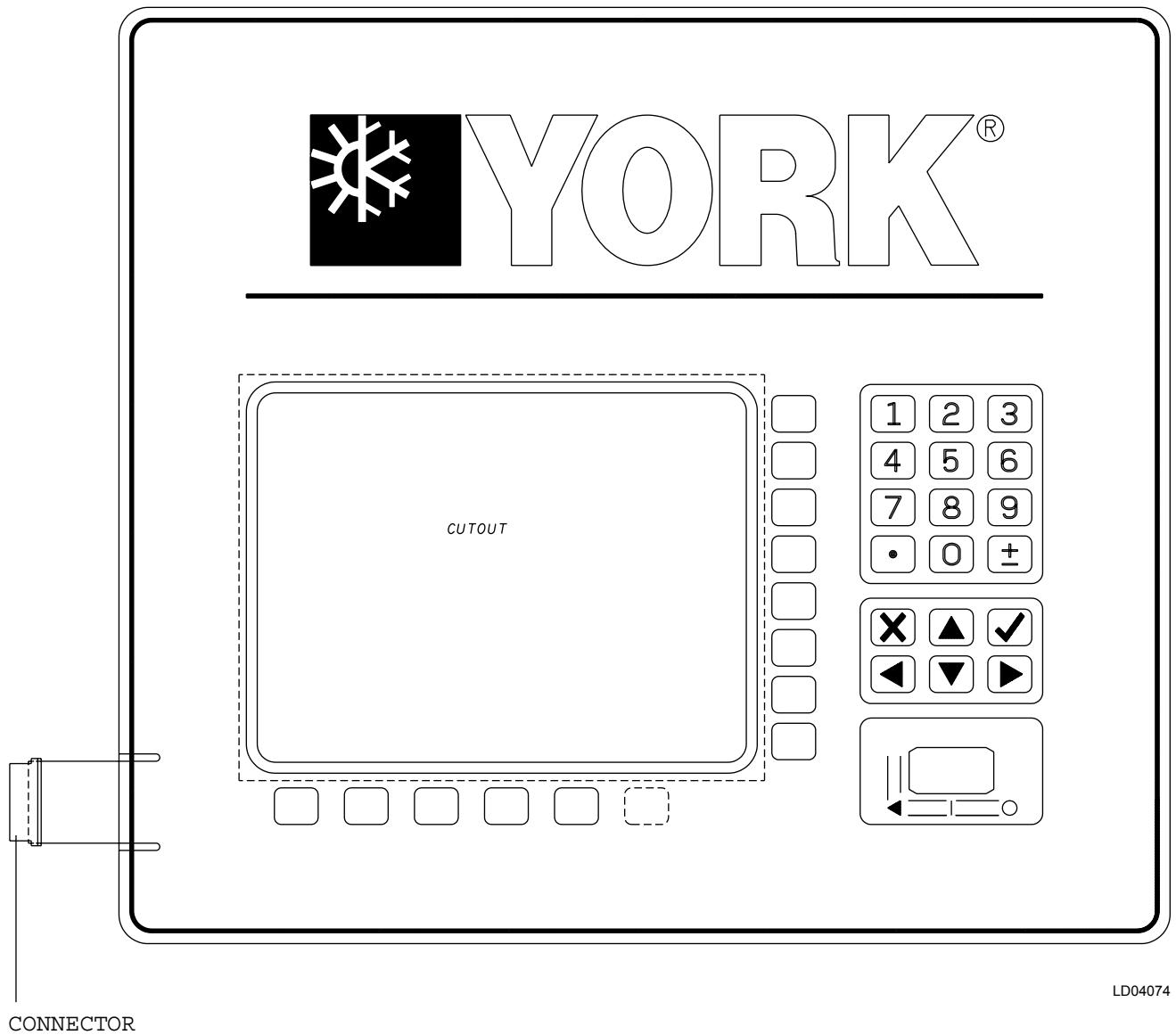
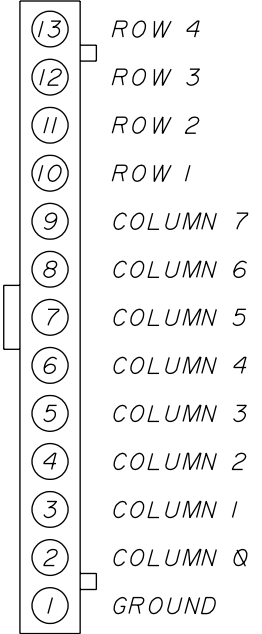
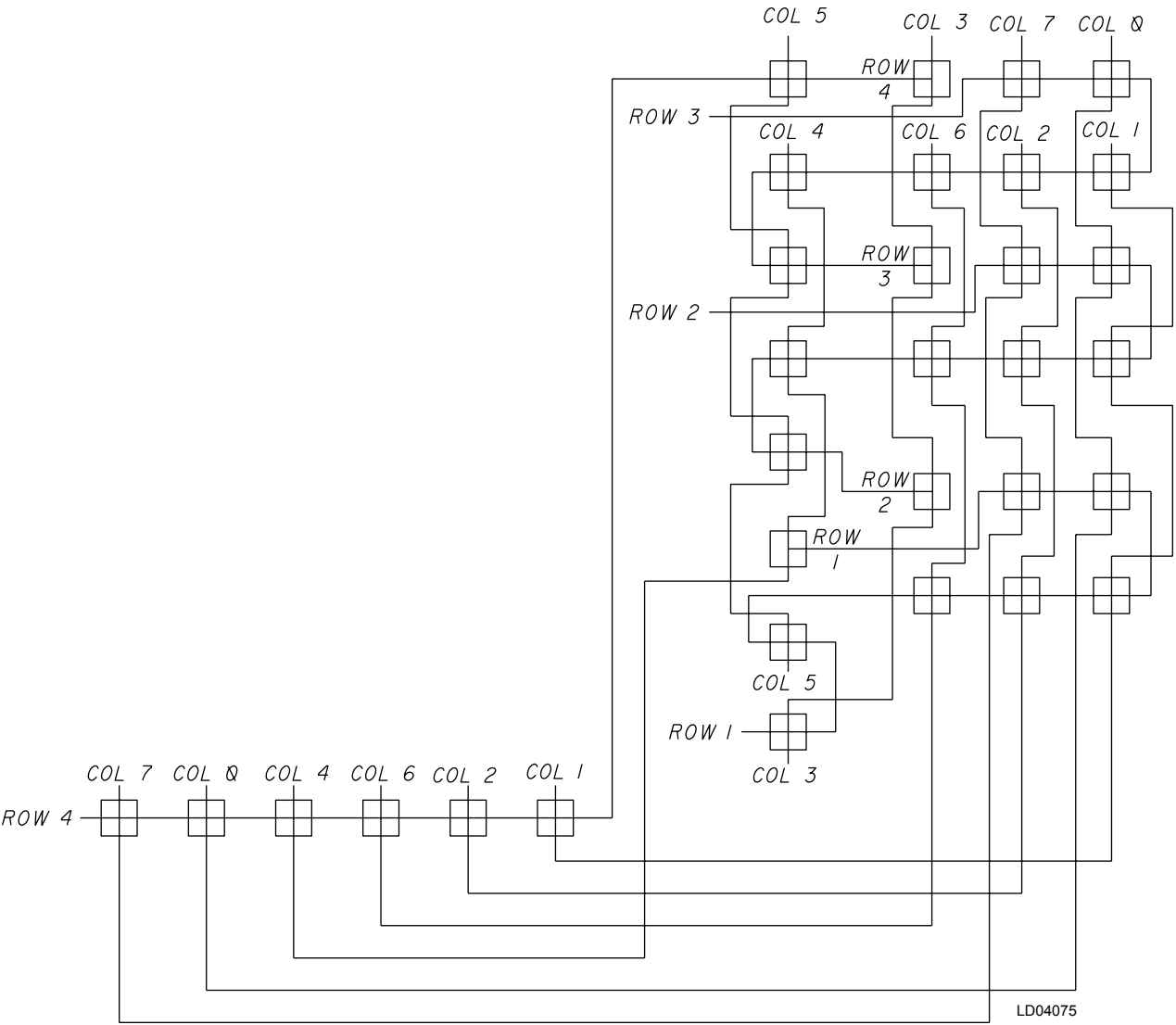

FIG. 32 – KEYPAD



CONNECTOR PIN OUT

LD04076

FIG. 33 – KEYPAD

SECTION 9 POWER SUPPLY (REFER TO FIG. 34 & 35)

The Power Supply provides the DC power for the LCD Display and all the printed circuit boards in the OptiView Control Center. It receives a 102 to 132VAC input from an external power source and provides the following DC outputs:

- -12VDC
- +12VDC
- +5VDC
- +24VDC
- Ground

The +24VDC output provides power to the CM-2 Board (Electro-Mechanical starter applications), Solid State Starter Logic Board (Mod “A” Solid State Starter), Solid State Starter Logic/Trigger Board (Mod “B” Solid State Starter) or Adaptive Capacity Control (ACC) (Variable Speed Drive applications). If the Chiller is equipped with Proximity Probe Part number 025-30961-000 or 025-35900-000, the Probe is also powered by this +24VDC.

The -12VDC, +12VDC, Gnd and +5VDC outputs are applied to the Microboard. There, these voltages are applied to the circuits requiring the respective voltage. From the Microboard, the +12VDC and +5VDC are distributed to other system components requiring these voltages. These include the MicroGateway, Proximity Probe (025-xxxx-000 only), I/O Board, VSD Oil Pump, LCD Display and Display Backlight Inverter Board. The Condor Power supply allows adjustment of the +5Vdc output. To account for losses in wiring and connections and assure sufficient voltage level at the microboard input, the “V Adj” (R51) potentiometer is adjusted to achieve +5.1Vdc at the input to the Microboard J1-1.

As shown in fig 9 (031-01730-000 microboard) and fig 9A (031-01730-000 microboard), the Microboard contains two voltage regulators that create separate +5VDC and +3.3VDC supplies. The +5VDC supply is dedicated to all the Microboard Analog circuits and is labeled as the +5VDC (Analog) supply. It is also routed to all Pressure Transducers, Temperature Thermistors, Proximity Probe and Motor controller Board (CM-2, Mod “A” Solid State Starter Logic Board or VSD ACC Board). This permits all Analog circuits to be powered by the same supply,

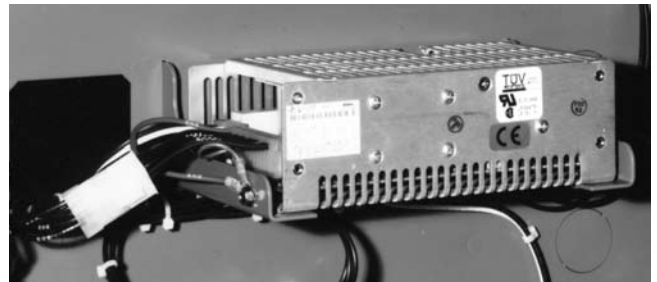

FIG. 34 – POWER SUPPLY

29136A

eliminating any offsets caused by voltage regulator drift. Microboard 031-02430-000 has an additional voltage regulator that provides a 2.5Vdc power source. The +3.3VDC supply is utilized by the Microprocessor, Flash Memory Card and other digital circuits. It could also be applied to the Backlight Inverter Board, depending on the Display manufacturer’s requirements as explained below.

Different Display manufacturers can require different supply voltages for their display and supporting circuits. To accommodate the different Display manufacturer’s voltage requirements, Microboard Program Jumpers JP2 and JP5 must be positioned to provide the required supply voltages to the Display and the Display Backlight Inverter Board. Either +5VDC or +3.3VDC, as determined by JP2, is applied to the Display. Either +12VDC or +5VDC, as determined by JP5, is applied to the Display Backlight Inverter Board. Refer to Table 1 “Microboard Program Jumpers”.

The chiller could be equipped with either of two Proximity Probes. The power supply requirements are different for these Probes. All Probes operate from a +5VDC power source. Probe 025-30961-000 and Probe 025-35900-000 require a +24VDC source that is tapped off of the supply to the CM-2 Current Module (Electro-Mechanical Starter applications), Solid State Starter Logic Board (Solid State Starter applications) or ACC Board (VSD applications) as shown in the Proximity Probe Section of this book.

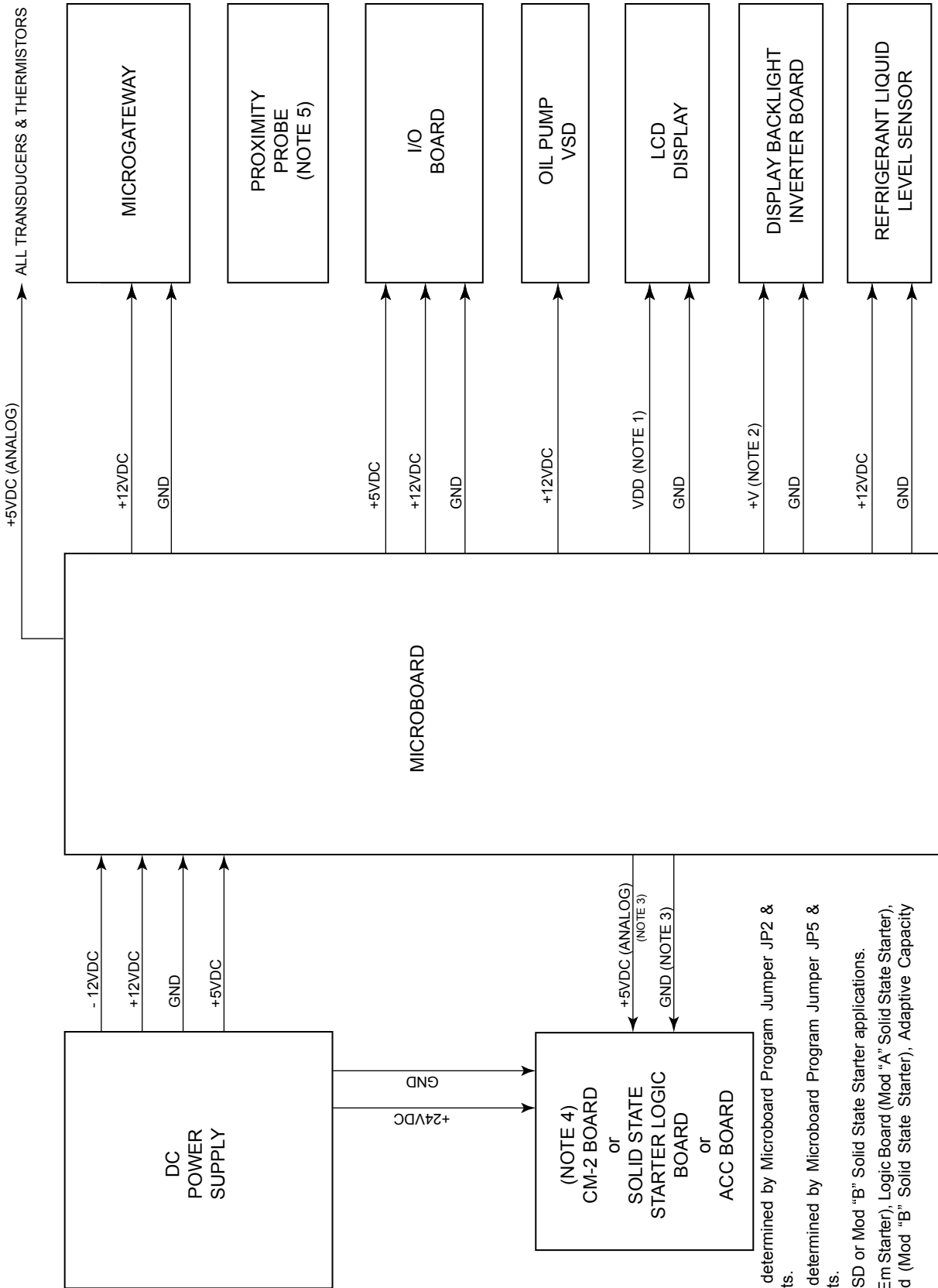

LD06509

NOTES:

1. +5 or +3.3VDC as determined by Microboard Program Jumper JP2 & display requirements.
2. +12 or +5VDC as determined by Microboard Program Jumper JP5 & display requirements.
3. Not Applicable to VSD or Mod "B" Solid State Starter applications.
4. Applications - CM2 (Em Starter), Logic Board (Mod "A" Solid State Starter), Logic/Trigger Board (Mod "B" Solid State Starter), Adaptive Capacity Control (VSD).
5. Refer to FIG. 45, 46 & 47 for Proximity Probe Power Connections. (Not applicable to "P" compressors and style F and later chillers with "G, Q" and "H5-8" compressors)

FIG. 35 – POWER SUPPLY – DC POWER DISTRIBUTION (REFER TO OPTIVIEW CONTROL CENTER WIRING DIAGRAM FOR WIRE CONNECTIONS)

SECTION 10 CURRENT MODULE (CM-2)

(REFER TO FIG 36 - 38)

On applications where the Compressor Motor is controlled by an Electro-Mechanical Starter, the OptiView Control Center is equipped with a **Current Module**. The Current Module provides compressor motor **Overload** and **Power Fault** protection. The Current Module also provides an analog voltage representing the compressor motor current to the Microboard for display and **Current Limit** control. While the chiller is running, the Microboard controls the Pre-rotation Vane (PRV) position to limit the motor current to the system 100% Full Load Amp (FLA) value.

The contacts of Current Module K1 relay (identified as “CM” contacts on the OptiView Control Center wiring diagram) are interfaced into the Motor Controller initiated shutdown circuit that is located between OptiView Control Center TB6-53 and I/O Board TB1-16 (ref. FIG 17 and 37). They are also connected as a digital input to I/O Board J2-1. Relay K1 is normally energized, maintaining its contacts in a closed position. Whenever the Current Module initiates a chiller shutdown, it de-energizes K1, opening its contacts. This interrupts the circuit to I/O Expansion Board RUN relay coil 1R (K18), de-energizing it and causing the Starter to shutdown. Simultaneously, the Microboard reads the opening of these contacts via I/O Board J2-1, initiates a **SYSTEM COASTDOWN** and displays the appropriate message as described below.

Three **Current Transformers** in the Compressor Motor Terminal Box (ref FIG. 38) provide 3 phase motor current signals to the **Diode Bridge** (DB). The required turns ratio of the Current Transformers is determined by the system 100% FLA. The Diode Bridge rectifies and combines the three signals into one DC signal that is applied to the parallel **Variable Resistors** (RES). These are Factory adjusted (field adjusted on service replacements) to provide a nominal 1.0VDC (0.15 to 1.10VDC) signal to the Current Module at J1-1 and J1-2 when the compressor motor current is at 100% FLA. FIG. 38 contains a formula to calculate the resistance of RES required to achieve 1.0VDC at 100%FLA. The 100% FLA value is located on a label adhered to the inside of the OptiView Control Center door.

The motor current signal input at J1-1 & J1-2 is applied to potentiometer R8. This is Factory adjusted (field adjusted on service replacements) to illuminate the 105% CURR indicator (CR6) when the compressor motor current reaches 105% FLA. This calibrated voltage is applied to the **Power Fault** detector, **Overload** detectors and Multiplexer (MUX).

The **Power Fault** circuit protects the compressor motor and driveline from transient torque damage. It anticipates the transient torque condition by detecting a momentary interruption in motor current and de-energizing the starter before damage can occur. If the chiller has been running for >75 seconds and the motor current decreases to $\leq 10\%$ FLA, a **Power Fault** shutdown is initiated. The **Power Fault** indicator (CR5) is illuminated and remains illuminated until manually reset with **RESET** switch S2. Relay K1 is de-energized for 1 second and then returned to the energized state. Relay K1 contacts (CM) open for 1 second and then return to the closed state. A **SYSTEM COASTDOWN** is initiated and **POWER FAULT** is displayed on the Display. The chiller will automatically restart upon completion of **SYSTEM COASTDOWN**.

If the motor current remains continuously at $\geq 105\%$ FLA for 50 seconds (Nominal), an **OVERLOAD** shutdown is initiated. The **Overload** indicator (CR4) is illuminated and remains illuminated until manually reset with **RESET** switch S2. Relay K1 is de-energized, opening K1 contacts (CM). Relay K1 remains de-energized until manually reset with **RESET** switch S2. A **SYSTEM COASTDOWN** is initiated and **MOTOR CONTROLLER-CONTACTS OPEN** is displayed. The chiller cannot be started until **RESET** switch S2 is manually pressed.

If the motor current remains continuously at 245% FLA for 40 seconds, 290% FLA for 20 seconds or 360% FLA for 10 seconds, an **OVERLOAD** shutdown is initiated. Relay K1 and **Overload** indicator CR4 operate as described immediately above. A **SYSTEM COASTDOWN** is initiated and **MOTOR CONTROLLER - CONTACTS OPEN** is displayed.

The chiller cannot be restarted until **RESET** switch is manually pressed. **LRA/FLA** Potentiometer R16 is factory adjusted (field adjusted on service replacements) to the ratio of Locked Rotor Amps to Full Load Amps. The correct setting is determined by dividing the LRA by the FLA. If Switch S1 is in the “Y-Delta/57%” position, there is no 245% FLA threshold. Switch S1 must be positioned according to the type of Electro-Mechanical starter present; **UP** for Y-delta or 57% Autotransformer starters, **DOWN** for all other starters.

The Multiplexer (MUX) is an electronic switch with 8 inputs and 1 output. The address applied to it determines the position of the switch (i.e., which input is routed to the output). The inputs to channel 0 through 6 are grounded (0VDC) . The input to channel 7 is a 0 to 4.0VDC analog signal, representing motor current over the range of 0 to 100% FLA. It is Factory calibrated by Potentiometer R34 to be 4.0VDC when the compressor motor current is at 100% FLA. Under Program control, the Microboard commands the **MUX** to route the inputs to the MUX output by applying 3-bit Binary addresses to the MUX address inputs at J5-1,2,3. The voltage level for a logic 1 is +12VDC and logic 0 is 0VDC. The Microboard reads the MUX outputs at J5-6. It first addresses channel 0 to determine the type of starter applied. The 0VDC at channel 0 indicates to the Microboard that this is an Electro-Mechanical Starter application (In all starter applications, the Micro reads channel 0 to determine the type starter applied; 0VDC = EM starter, >0VDC=Solid State Starter). It then addresses channel 7 (ignoring channels 1 through 6) to read the analog motor current voltage. The Microboard interprets this analog value in terms of %FLA and displays it upon operator keypad request. It also uses this value to invoke compressor motor **Current Limit** at 100% FLA and 104% FLA. When motor current rises to 100% FLA, the Microboard prevents any further current rise by inhibiting further Pre-rotation Vanes (PRV) opening until it

decreases to 98% FLA. If the motor current continues to rise to 104% FLA, the Microboard applies a close signal to the PRV until the motor current decreases to 102% FLA. While **Current Limit** is in effect, **MOTOR - HIGH CURRENT LIMIT** is displayed.

As detailed in the “System Calibration” section of this book, to field calibrate Potentiometer R8, the PRV must be manually operated to achieve 105% FLA compressor motor current. Therefore, during this procedure, **Current Limit** is not invoked until 107% FLA and 110% FLA. The first time the **PRV OPEN** key is pressed on the **COMPRESSOR** Screen after logging in at **SERVICE** access level, a 10 minute window is opened, allowing the current to rise to 107% FLA before further PRV opening is inhibited. This inhibit is released when the current decreases to 106% FLA. If the current continues to rise to 110%, manual control is overridden and a close signal is applied to the PRV until the current decreases to 109% FLA. After 10 minutes, the normal current limit thresholds of 100% FLA and 104% FLA are applied.

The MUX address inputs along with respective outputs are as follows:

BINARY			DECIMAL	OUTPUT
J5-1	J5-2	J5-3		
0	0	0	0	Ground
0	0	1	1	Ground
0	1	0	2	Ground
0	1	1	3	Ground
1	0	0	4	Ground
1	0	1	5	Ground
1	1	0	6	Ground
1	1	1	7	0-5.0VDC motor current analog signal calibrated on CM-2 board to be +4.0VDC at 100% FLA.

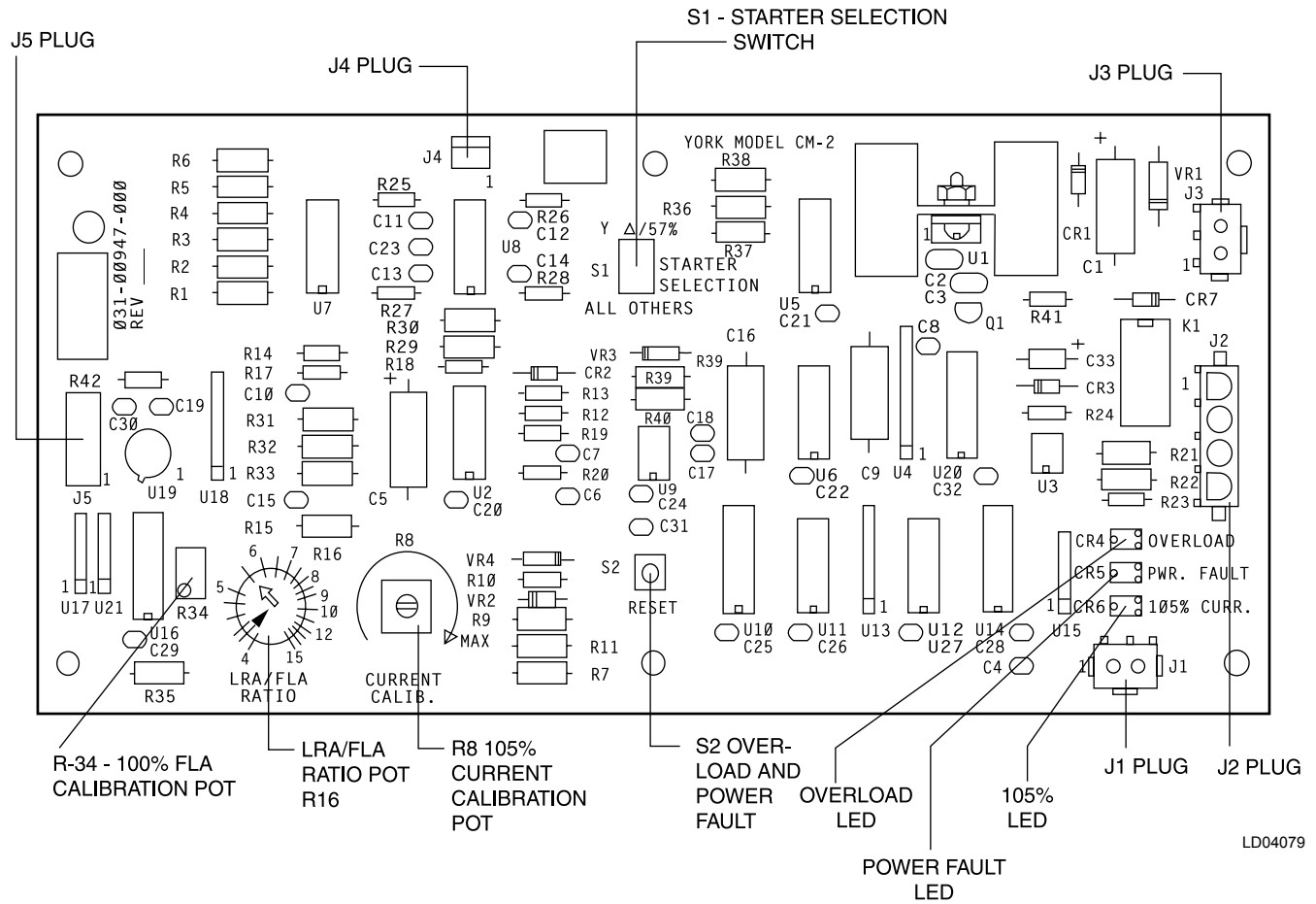

FIG. 36 – CM-2 CURRENT MODULE (ELECTRO-MECHANICAL STARTER APPLICATION)

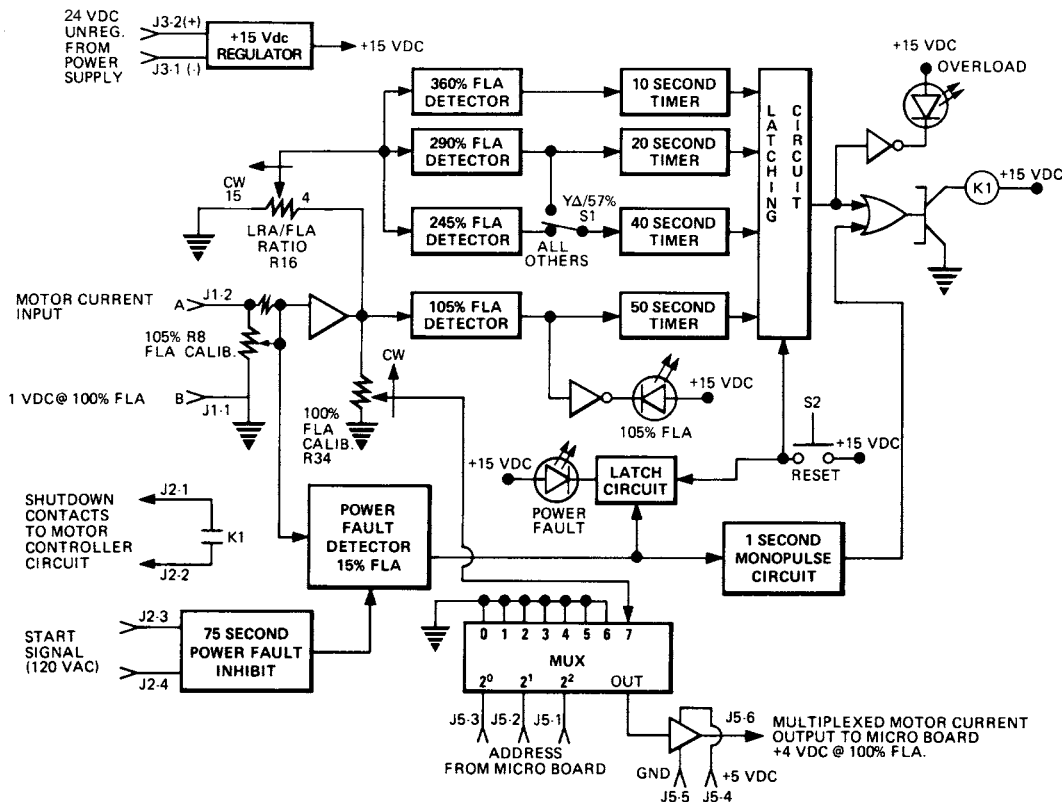
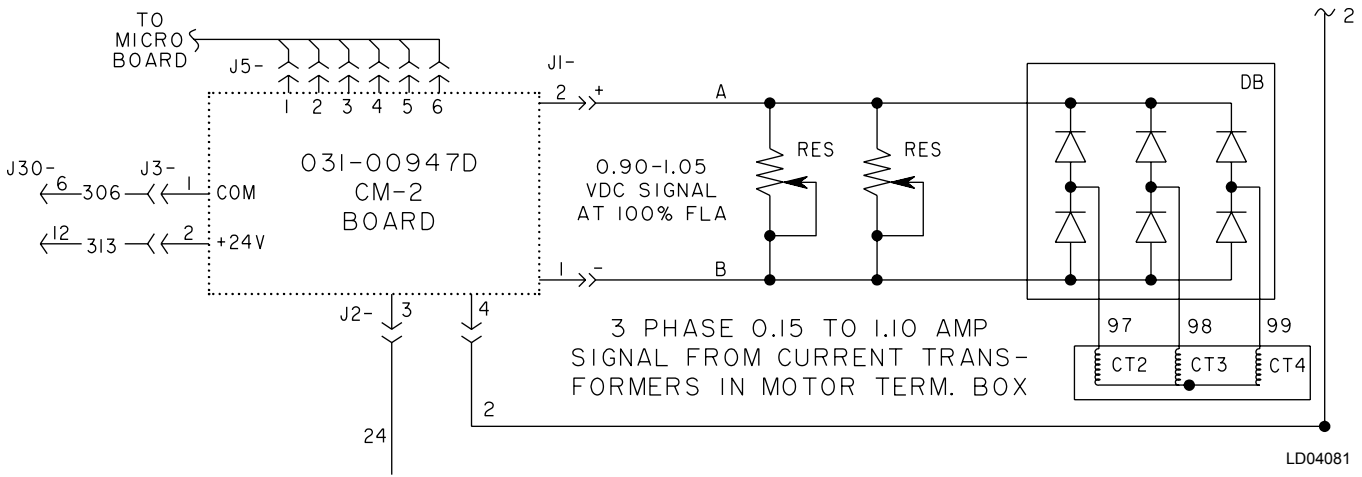

FIG. 37 – CM-2 CURRENT MODULE (ELECTRO-MECHANICAL STARTER APPLICATIONS)



LD04081

MOTOR VOLTAGE	FLA	CT RATIO	RES ^D (OHMS)
208-600	65-111 ^A	200:1	R = 1.282 (CT RATIO) FLA
	112-224 ^A	350:1	
	225-829 ^A	700:1	
	830-1790 ^A	1400:1	
2300-4160	11-18 ^C	200:1	R = 0.247 (CT RATIO) FLA
	19-37 ^B	200:1	R = 0.370 (CT RATIO) FLA
	38-123 ^A	200:1	R = 0.740 (CT RATIO) FLA
	124-264 ^A	350:1	
	265-518 ^A	700:1	

NOTES:

- A. Requires passing motor lead through current transformer (CT) **once** before connecting to power supply.
- B. Requires passing motor lead through CT **twice** before connecting to power supply.
- C. Requires passing motor lead through CT **three** times before connecting to power supply.
- D. Calculates resistance of "RES" to achieve 1.0VDC at FLA.

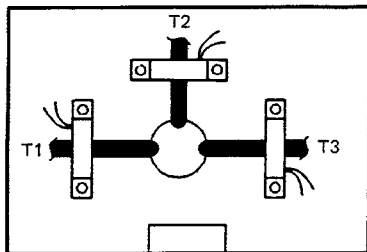
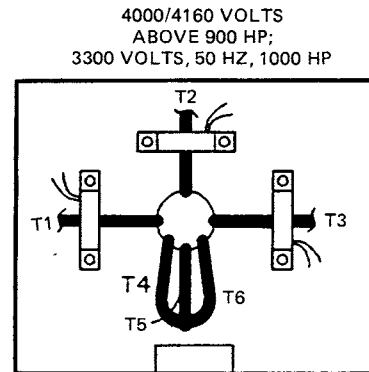
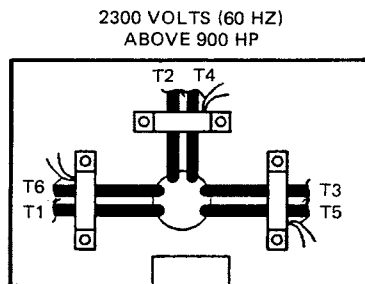
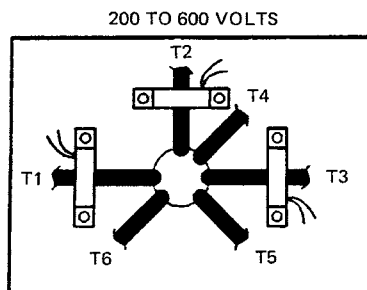

2300 TO 4160 VOLTS THRU 900 HP;
2300 VOLTS, 50 HZ ABOVE 900 HP;
3000 TO 3300 VOLTS ABOVE 900 HP,
EXCEPT 3300 VOLTS, 50 HZ, 1000 HP

LD04082

FIG. 38 – CM-2 CURRENT MODULE – INTERFACE, CURRENT TRANSFORMERS & VARIABLE RESISTORS

SECTION 11 SOLID STATE STARTERS

(REFER TO FIG. 39 - 41)

SOLID STATE STARTERS

The OptiView Control Center will accommodate several different Solid State Starters. Later vintage chillers are equipped with either the Medium Voltage Solid State Starter (MV SSS) or the Style B Liquid Cooled Solid State Starter (LCSSS). The MV SSS communicates with the microboard using RS-485 serial data with Modbus protocol. The Style B LCSSS contains an integrated Logic/Trigger Board located in the starter cabinet. This board communicates with the microboard using serial communications: Early vintage boards use an opto-coupled interface with YORK protocol. Later vintage boards (after mid 2008) use an RS-485 interface with MODBUS protocol. The Style A LCSSS was in production prior to the Style B LCSSS. With the Style A LCSSS, a Trigger Board resides inside the starter cabinet and a separate Logic Board is located inside the OptiView cabinet. This version communicates with the microboard via a multiplexed data interface.

If equipped with microboard 031-01730-000, Program Jumper JP39 must be positioned to invoke appropriate microboard operation for the starter applied (Refer to table 1). If equipped with microboard 031-02430-000/001, the starter selection is performed on the SETUP Screen (refer to Section 23).

MEDIUM VOLTAGE SOLID STATE STARTER

The Medium Voltage Solid State Starter (MV SSS) communicates with the microboard J13 COM 2 port with RS-485 serial data using Modbus protocol. This communication link transfers start/stop commands to the starter and receives status and operation data from the starter. A hardwired 115VAC start signal is also applied to the starter via relay 1R (K18) contact closure. A Starter Initiated STOP relay, located in the starter, opens its contacts whenever the starter initiates a shutdown. The communications link and relay contact interface operate in the same way as described below for the Style B LCSSS.

Microboard 031-02430-001, equipped with the 128K BRAM and software C.OPT.01.15.xxx (or later) is required for this application. Microboard Program Jumpers JP14 and JP17 must be positioned appropriately. Refer to SECTION 3A of this manual. On the SETUP Screen "MVSSS" must be selected for the MOTOR DRIVE TYPE Setpoint.

The MV SSS Motor Screen contains information pertinent to the starter. A complete description, theory and operation of this starter are contained in YORK service manual 160.00-M5.

Style "B" Serial Interface LCSSS (Refer to FIG. 39)

A complete description, theory of operation and troubleshooting instructions of this LCSSS are contained in YORK Service Manual 160.00-O2. The following describes the interface and interaction of the LCSSS with the OptiView Control Center.

As shown in FIG. 39, the LCSSS contains a single Logic/Trigger printed circuit board. This board performs the following functions:

- Generates the SCR trigger pulses
- Receives start/stop commands from the Microboard
- Transmits status and fault data to the Microboard
- Generates all LCSSS initiated Safety and Cycling shutdowns.

The Logic/Trigger Board is powered by +24VDC from the OptiView Control Center Power Supply. The OptiView Control Center Microboard (J15) communicates with this board via a 1200 baud 0/+5VDC serial data communications link. If this communications link does not operate properly, correct Microboard J15 serial port operation can be verified using the Serial Inputs and Outputs diagnostic procedure in the "Diagnostics and Troubleshooting" section of this book. The **STOP** relay contacts on the Logic/Trigger Board assure a positive shutdown on all LCSSS initiated shutdowns.

After power has been applied to the system, the Microboard will attempt to establish communications with the Logic/Trigger Board. If unsuccessful within 10 attempts, the Microboard initiates a Cycling shutdown and displays "**LCSSS INITIALIZATION FAILED**" on the System Details line of the OptiView Control Center display. The Microboard will continue to establish communications until successful. Also, at power-up, the Logic/Trigger Board reads wire jumpers in its connector J1 to determine the LCSSS model applied (refer to 160.00-O2). If an invalid jumper configuration is read, the Logic/trigger Board initiates a Cycling shutdown and "**LCSSS - INVALID CURRENT SCALE SELECTION**" is displayed on the System Details line of

the OptiView Control Center Display. The model designation is transmitted to the Microboard for display on the **MOTOR** Screen. This designation determines the allowable range for the Full Load Amps (FLA) Setpoint and Start Current Setpoint. There are 4 LCSSS models: 7L, 14L, 26L and 33L. Each model has an allowable Full Load Amps (FLA) range and Start Current range as listed below.

Communications between the Microboard and Logic/Trigger Board are in the form of master/slave. The Microboard is the master and the Logic/Trigger Board is the slave. The Logic/Trigger Board sends two types of data to the Microboard: Status data and Fault data. After successful initialization, the Microboard sends a data request every 2 seconds. Normally, the Logic/Trigger Board responds to each request. However, if the Microboard does not receive a response to 10 consecutive requests, the Microboard initiates a Cycling shutdown and displays “**LCSSS - SERIAL COMMUNICATIONS**” on the System Details line of the OptiView Control Center display. In addition, the Logic/Trigger Board will initiate the same Cycling shutdown if it does not receive a data request from the Microboard after 10 successive attempts to send data.

Prior to June 2006, new production chillers are equipped with microboard 031-01730-000 (early vintage) or 031-02430-000 (later vintage). The COM5 (J15) serial port on these boards communicates with the starter Logic/Trigger Board 031-02001 (TB2) using YORK protocol. Refer to FIG. 39.

After June 2006, microboard 031-02430-001 is supplied in new production chillers. Until March 2007, the COM 5 (J15) serial port of this board communicates with Logic/Trigger Board 031-02001 (TB2) using YORK protocol. Refer to FIG. 39. After March 2007, this Logic/Trigger Board is replaced with 031-02505 in new production chillers. YORK protocol is used until mid 2008. Refer to FIG. 39A.

On new production chillers after mid 2008, microboard 031-02430-001 COM 2 (J13) serial port communicates with Logic/Trigger Board 031-02505 (J14) using RS-485 MODBUS protocol. Refer to FIG. 39B. This configuration requires Software version C.OPT.01.18.307 (or later). When using COM 2 serial port for starter communications, microboard Program Jumper JP17 must be placed on pins 1 & 2. On the Setup Screen, the COM 2 serial port is enabled by setting the Motor Communications Protocol Setpoint to MODBUS. The Motor Node ID Setpoint must be set to “1” to match the Modbus Address assigned to the starter. The Modbus Ad-

dress is set to “1” in the starter by placing Logic/Trigger Board switch SW1 position 1 to “ON”; all other positions to “OFF”. If the Motor Node ID does not match the Modbus Address assigned to the Logic/Trigger Board, the Logic/Trigger Board will not communicate with the microboard.

After June 2006, microboard 031-02430-001 is supplied as service replacement for all previous microboards. To allow it to be backward compatible to all existing chillers, this board contains both the COM 5 opto-coupled YORK protocol serial port (J15) and the COM 2 RS-485 Modbus serial port (J13). Refer to figure 39, 39A and 39B.

After March 2007, Logic/Trigger Board 031-02505 is supplied as service replacement for all previous Logic/Trigger Boards. To allow it to be backward compatible to all existing chillers, this board contains both an opto-coupled YORK protocol serial port (TB2) and a RS-485 Modbus serial port (J14). Refer to FIG. 39, 39A and 39B.

Anytime the Logic/Trigger Board initiates a Cycling or Safety shutdown, it opens its **STOP** contacts that are connected in series with the OptiView Control Center’s 1R (K18) **RUN** relay coil. The contacts remain open as long as the condition exists. The open **STOP** contacts interrupt the circuit to 1R causing it to de-energize, removing the run signal to the LCSSS. Simultaneously, the Microboard reads the opening of the LCSSS STOP contacts via the I/O Board J2- 1. This signals the Microboard that the LCSSS has initiated a shutdown. The Logic/Trigger Board sends the cause of the shutdown in response to the next data request. This is logged on the **HISTORY** Screen as the “**LAST FAULT WHILE RUNNING**”. A snapshot of the LCSSS operating parameters valid at the instant of the fault are also sent. Any additional faults that occur within the 2 second transmission time are also sent and logged on the **HISTORY** Screen under “**LAST TEN FAULTS**”. Refer to Operation Manual 160.54-O1 for description of all Cycling and Safety shutdown messages. While this data is being sent, “**LCSSS - SHUTDOWN - REQUESTING FAULT DATA**” is displayed on the System Details line of the OptiView Control Center display. If fault data is not returned within 2 seconds, the Microboard will continue to send a request at 2 second intervals until the fault data is returned. If none is returned within 10 consecutive requests, it assumes it is not forthcoming and it displays “**LCSSS - STOP CONTACTS OPEN**” on the System Details line of the display.

The chiller can be started if there are no Safety and Cycling conditions. If the temperature of any of the SCR modules are >110°F, the LCSSS cooling pump will run and the chiller will be inhibited from starting until the temperature has decreased below 109°F. While this start inhibit is in effect, “**LCSSS - HIGH TEMPERATURE PHASE X - STOPPED**” (where X is phase A, B, or C) is displayed on the System Details line of the display. When the chiller is started, the OptiView Control Center sends two start signals simultaneously to the Logic/Trigger Board. One is transmitted via the serial communications link. The other is the closure of 1R (K18) Start relay, applying 115VAC to Logic/Trigger Board TB1-24. If these two signals are not received within 5 seconds of one another, the Logic/Trigger Board initiates a cycling shutdown and “**LCSSS - RUN SIGNAL**” is displayed on the System Details line of the display.

The Logic/Trigger Board transmits the following parameters over the serial communications link for display on the **MOTOR** Screen:

- Three phase motor current
- Three phase line-to-line motor supply voltage
- Input Power (KW)
- Three phase SCR module temperature
- Starter model designation

The following are the programmable setpoints associated with the LCSSS. They are programmed on the **MOTOR** Screen. Refer to programming instructions in the “System Calibration, Service Setpoints and Reset Procedures” section of this book.

- **Full Load Amps** - This is the maximum allowed motor current at which this chiller is permitted to operate to achieve maximum design capacity. It is the Full Load Amps (FLA) of the chiller, as listed on the **SALES ORDER** Screen. Each starter model has a permissible range over which this setpoint can be programmed as follows:

LCSSS Model	Permissible FLA
7L-46, 58 and 50	35 to 260 Amps
14L-17, 28, 46, 58 and 50	65 to 510 Amps
26L-17, 28, 46, 58 and 50	125 to 850 Amps
33L-17, 28, 46 and 50	215 to 1050 Amps

- **Start Current** - The Logic/Trigger Board will limit inrush motor current to this value during starting. The programmed value is sent to the Logic/Trigger Board over the serial communications link. This setpoint should be programmed to (0.45 x motor Delta Locked Rotor Amps) as listed on the **SALES ORDER** Screen. Each model starter has a permissible range over which this setpoint can be programmed as follows:

LCSSS Model	Permissible Start Current Range
7L-46, 58 and 50	310 to 700 Amps
14L- 17, 28, 46, 58 and 50	620 to 1400 Amps
26L- 17, 28, 46, 58 and 50	1150 to 2600 Amps
33L-17, 28, 46 and 50	1460 to 3300 Amps

- **Supply Line Voltage Range** - This setpoint is the line voltage application and establishes the high and low line voltage shutdown thresholds. Shutdown and restart thresholds are contained in Operation manual 160.54-O1 under the messages “**LCSSS - LOW SUPPLY LINE VOLTAGE**” and “**LCSSS - HIGH SUPPLY LINE VOLTAGE**”.
- **Open SCR Enable/Disable** - This enables or disables the Open SCR detection Safety protection performed by the Logic/Trigger Board. This protection must **never** be disabled unless advised by the YORK factory.
- **Kilowatt Hours (KWH) Reset** - This allows the accumulated KWH to be set to a desired starting value in the event the BRAM has to be field replaced. This must **never** be arbitrarily performed.

To assure the chiller is not permitted to run for extended periods with the supply line voltage outside of acceptable limits, the Logic/Trigger Board compares the actual 3-phase line voltage to the thresholds established with the Supply Line Voltage Range setpoint. Each supply voltage application has an allowable upper and lower limit. If the supply voltage goes above or below these limits continuously for 20 seconds, the logic trigger Board initiates a Cycling shutdown and displays “**LCSSS - HIGH SUPPLY LINE VOLTAGE**” or “**LCSSS - LOW SUPPLY LINE VOLTAGE**” as appropriate. The chiller will automatically restart when the line voltage is within the acceptable range.

While the chiller is running, the Microboard will close or inhibit opening of the Pre-rotation Vanes (PRV), as

required, to limit the compressor motor current to the Current Limit or Pulldown Demand Limit setpoint (30% to 100% FLA) that is in effect. The Microboard calculates the “% Full Load Amps” (FLA) by dividing the highest phase of the 3-phase motor current, received from the Logic/Trigger Board, by the value programmed for the **FULL LOAD AMPS** setpoint. “% **FULL LOAD AMPS**” is displayed on the **MOTOR** Screen. If the motor current increases to the extent that the “% **FULL LOAD AMPS**” reaches 100% of the Current Limit

Setpoint, the PRV are inhibited from further opening until the motor current decreases to $\leq 98\%$ of the Current Limit setpoint. If the motor current increases to the extent that the “% **FULL LOAD AMPS**” is 104% of the Current Limit setpoint, the PRV will be driven closed until the “% **FULL LOAD AMPS**” decreases to 102% of the Current Limit setpoint. The PRV opening will then be inhibited until the “% **FULL LOAD AMPS**” decreases to $\leq 98\%$ of the Current Limit setpoint.

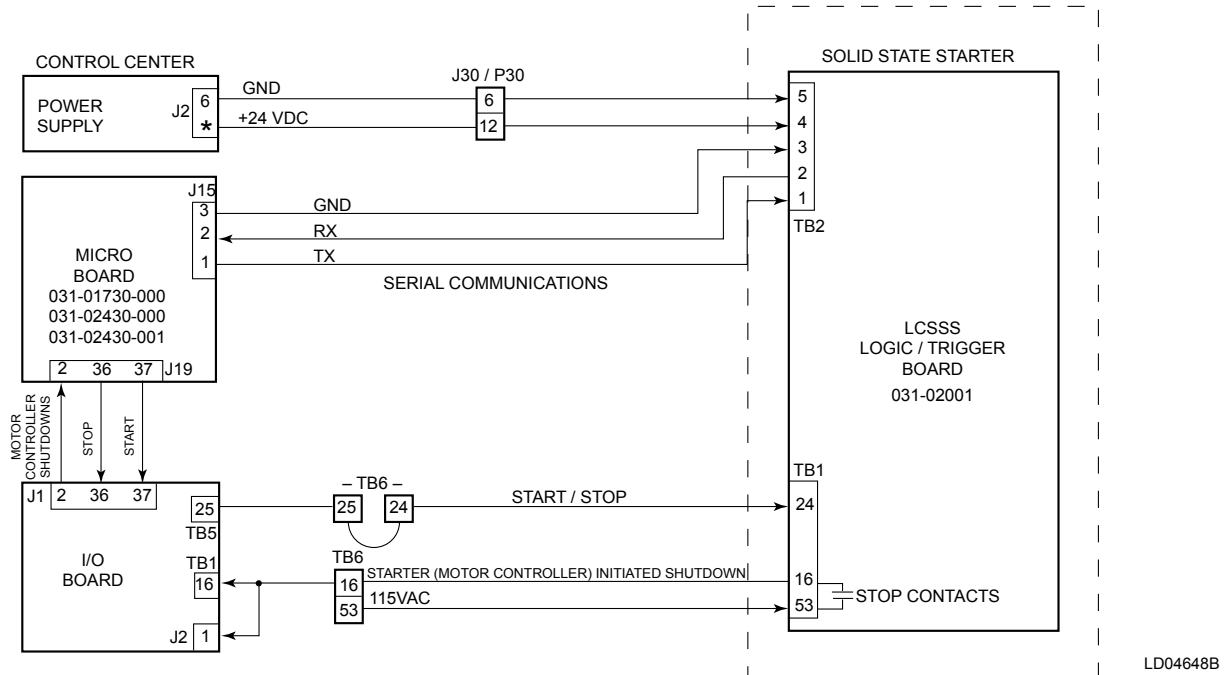

FIG. 39 – STYLE “B” LIQUID COOLED SOLID STATE STARTER (LCSSS) - INTERFACE (YORK PROTOCOL)

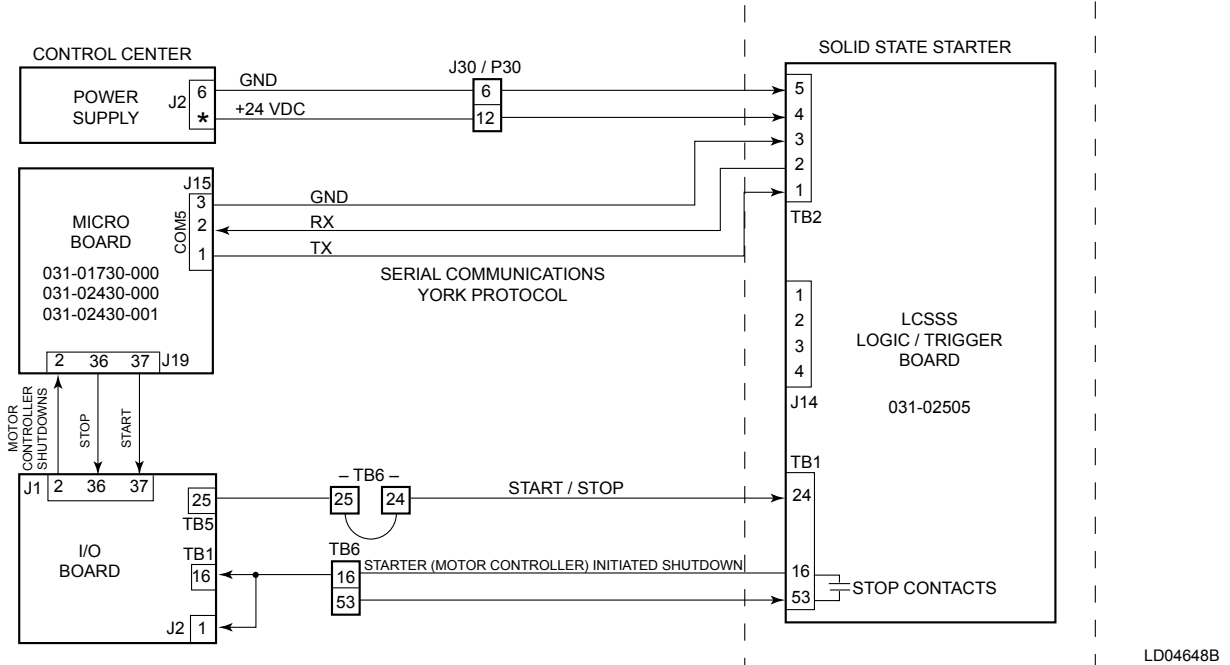
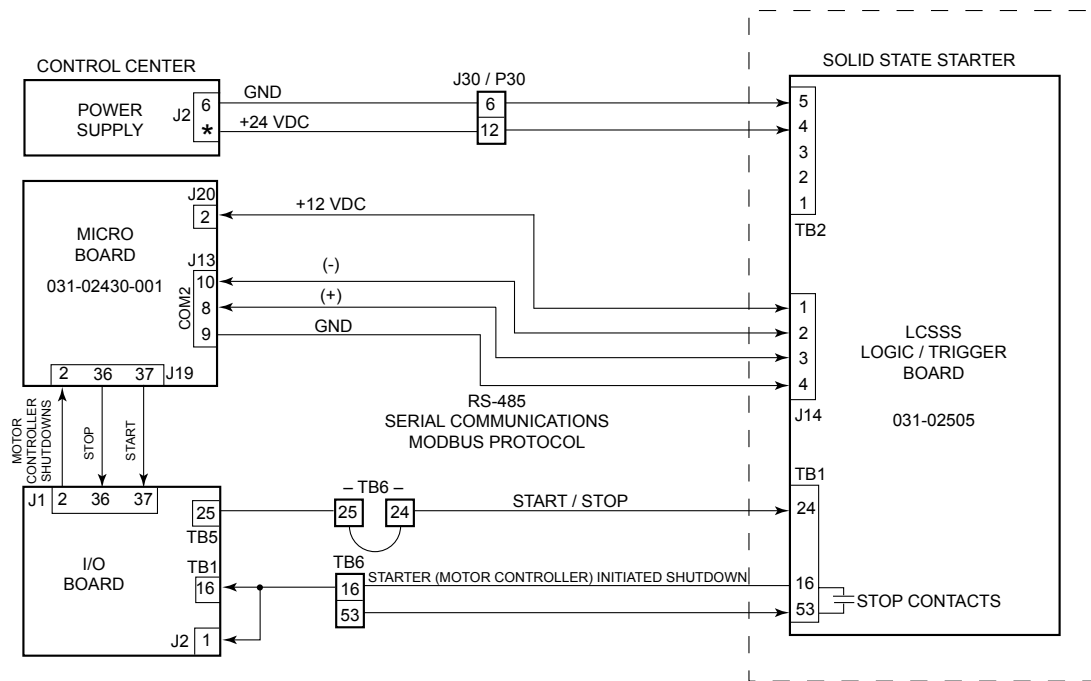

FIG. 39A – STYLE “B” LIQUID COOLED SOLID STATE STARTER (LCSSS) - INTERFACE (YORK PROTOCOL)



NOTES:

*9 – "CONDOR" Power Supply; 13 – "POWER ONE" Power Supply

LD04648C

FIG. 39B – STYLE "B" LIQUID COOLED SOLID STATE STARTER (LCSSS) - INTERFACE (MODBUS PROTOCOL)

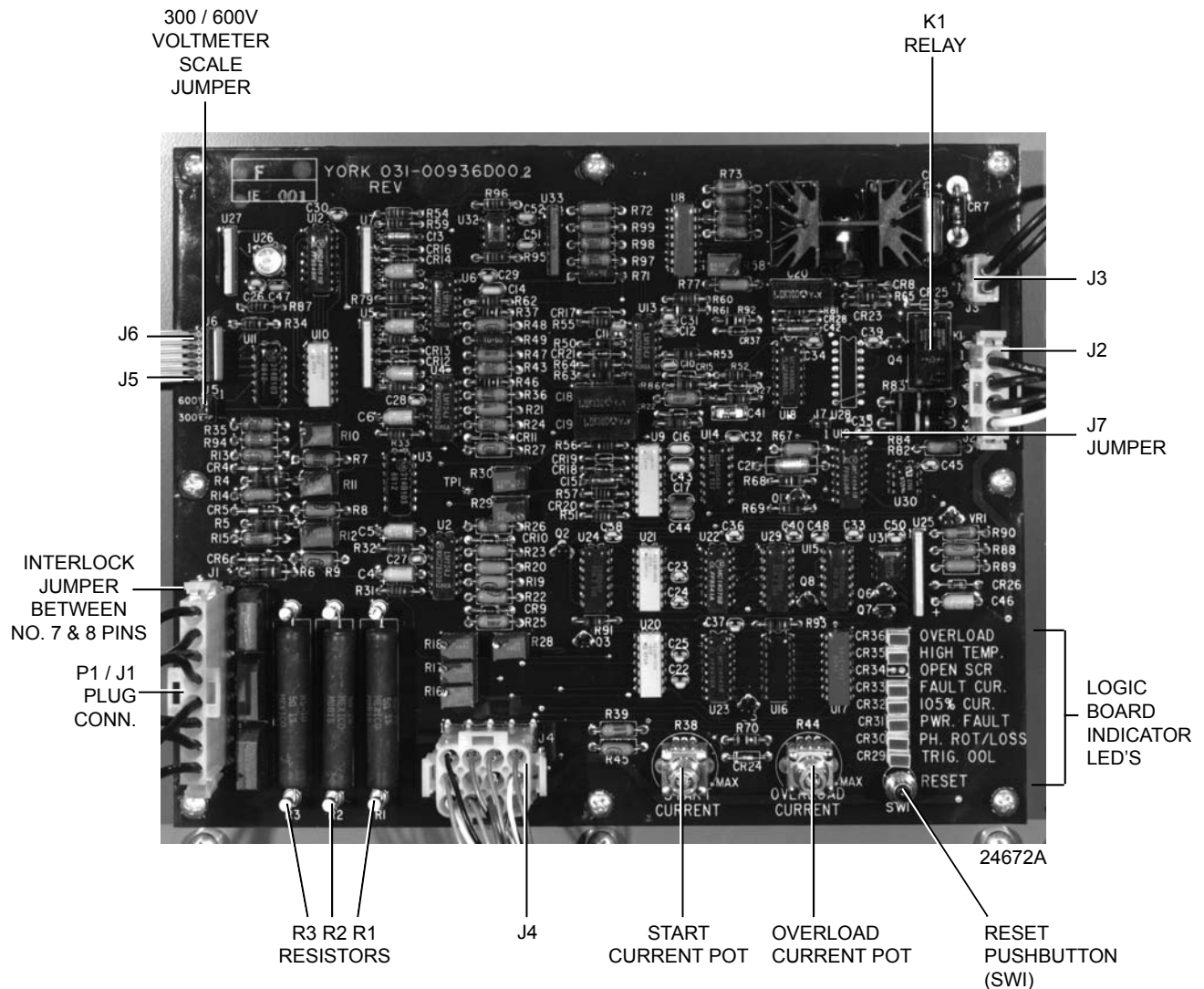

FIG. 40 – SOLID STATE STARTER LOGIC BOARD

This board provides **Overload**, **Power Fault**, **Fault Current**, **Phase Rotation/Loss**, and **Half Phase Protection** for the Compressor Motor. It also receives SCR High Temp and Trigger Out Of Lock (OOL) shutdown signals from the Starter Trigger Board. Finally, it provides analog voltages representing Compressor Motor Current, Power Line Voltage, Current Limit commands and a Starter Model code to the Microboard.

The contacts of Logic Board relay K1 (identified as “CM” contacts on the OptiView Control Center wiring diagram) are interfaced into the Motor Controller initiated shutdown circuit that is located between OptiView Control Center TB6-53 and I/O Board TB1-16 (ref. FIG. 16 and 37). They are also connected as a digital input to I/O Board J2-1. Relay K1 is normally energized, maintaining its contacts in a closed position. Whenever the Logic Board initiates a chiller shutdown, it de-energizes K1, opening its contacts. This interrupts the circuit to I/O Board RUN relay coil 1R (K18), de-energizing it and causing the Starter to de-energize. Simultaneously, the Microboard reads the opening of these contacts via I/O Board J2-1, initiates a **SYSTEM COASTDOWN** and displays the appropriate message as described below.

When the Logic Board detects an **Overload** condition, Relay K1 contacts open and the **Overload** LED illuminates. “**MOTOR CONTROLLER – CONTACTS OPEN**” is displayed. The contacts remain open and the LED remains illuminated until manually reset with the Logic Board’s S1 **RESET** switch. After S1 is pressed, the chiller can be restarted.

When a **Power Fault**, **Fault Current** or **Half Phase** condition is detected, Relay K1 contacts open for 1 second and then close. The **Power Fault** LED illuminates and will remain illuminated until manually reset with the S1 **RESET** switch. **POWER FAULT** is displayed. At the completion of **SYSTEM COASTDOWN**, the chiller will automatically restart.

When a Power line Phase Rotation/Loss or Trigger Board Out of Lock (OOL) condition is detected, Relay K1 contacts open and remain open for as long as the condition exists. If the contacts remain open for more than 3 seconds, **MOTOR CONTROLLER – CONTACTS OPEN** is displayed; if less than 3 seconds, **POWER FAULT** is displayed. The respective Ph. Rot/Loss or Trig. OOL LED illuminates and remains illuminated until manually reset with the S1 **RESET** switch. The chiller will automatically restart when the contacts close.

The Starter Trigger Board monitors the Starter’s Silicon Controlled Rectifier (SCR) heatsink temperature.

Whenever the heatsink temperature increases to 212°F, the Trigger Board signals the Logic Board. **MOTOR CONTROLLER – CONTACTS OPEN** is displayed. The Logic Board illuminates the **High Temp LED** and opens Relay K1 contacts. The LED remains illuminated and the contacts remain open until the temperature decreases to less than 110°F and manually reset with the Logic Board’s S1 **RESET** switch. After S1 is pressed, the chiller can be restarted. In routine operation, each time the chiller is shutdown for any reason, it is prevented from restarting until the heatsink temperature decreases to less than 110°F. While it is waiting for the temperature to decrease to this threshold, the **HIGH TEMPLED** is illuminated, Relay K1 contacts are open, and **MOTOR CONTROLLER – CONTACTS OPEN** is displayed. When the temperature is below 110°F, K1 contacts will open, the LED is extinguished, **MOTOR CONTROLLER – CONTACTS OPEN** message is cleared and the chiller will automatically restart.

The Multiplexer (MUX) is an electronic switch with 8 inputs and 1 output. The address applied to it determines the position of the switch and therefore the output. Under Program control, the Microboard sequentially addresses MUX channels 0 through 7. The voltage output of each channel is listed in the table below. Channel 0 is an analog voltage that represents the Starter model and Power Line voltage Voltmeter scale. The Program uses this value to limit the Full Load Amps Setpoint range to the maximum allowed value for the Starter size. This value also determines the Line Voltage display range and Motor current display range. Channel 1 is a current limit command that forces the Micro to perform Pre-rotation vanes inhibit and closure at the 100% and 104% FLA. This command is in addition to the Micro’s software current limit feature that’s based on a calculation comparing the highest current phase to the programmed Full Load Amp Setpoint to arrive at an FLA Percentage. Channels 2 through 4 are analog voltages representing Phase C, B and A Power Line Voltages. Channels 5 through 7 are analog voltages representing Phase A, B and C Compressor Motor Current. The addresses are +12VDC for logic high (1). <1VDC for logic low (0).

The Logic Board MUX address inputs, along with the respective outputs are as follows:

Mod “A” Multiplexed Data Interface LCSSS (Refer to FIG. 41)

A complete description, theory of operation and troubleshooting instructions of this LCSSS are contained YORK Service Manual 160.46-OM3. 1.

As shown in FIG. 41, the Logic Board of this model starter is mounted inside the OptiView Control Center.

BINARY			DECIMAL	OUTPUT
J6-1	J6-2	J6-3		
0	0	0	0	Starter Model/Voltmeter/Ammeter full scale, max FLA: 0.41 to 0.77VDC - 7L, 600VAC, max FLA 281, full scale 787A 0.78 to 1.22VDC – 14L, 300VAC, max FLA 551, full scale 1574A 1.23 to 1.76VDC – 14L, 600VAC, max FLA 551, full scale 1574A 1.77 to 2.39VDC – 26L, 300VAC, max FLA 916, full scale 2938A 2.40 to 3.08VDC – 26L, 600VAC, max FLA 916, full scale 2938A 3.09 to 3.87VDC – 33L, 300VAC, max FLA 1134, full scale 3672A 3.88 to 5.00VDC – 33L, 600VAC, max FLA 1134, full scale 3672A
0	0	1	1	Current Limit commands 3.46 to 5.00VDC - <98% FLA 1.21 to 3.45VDC - ≥100% FLA 0.0 to 1.20VDC - ≥104% FLA
0	1	0	2	Phase “C” AC Power Line voltage as follows: $300\text{VAC scale} = \frac{\text{VDC(out)}}{67.9}$ $600\text{VAC scale} = \frac{\text{VDC(out)}}{135.8}$
0	1	1	3	Phase “B” AC Power Line voltage. Same as Phase “C” above.
1	0	0	4	Phase “A” AC Power Line voltage Same as Phase “C” above.
1	0	1	5	Phase “A” Compressor Motor Current. 0 to +5VDC spanning range in address 0 above.
1	1	0	6	Phase “B” Compressor Motor Current. 0 to +5VDC spanning range in address 0 above.
1	1	1	7	Phase “C” Compressor Motor Current. 0 to +5VDC spanning range in address 0 above.

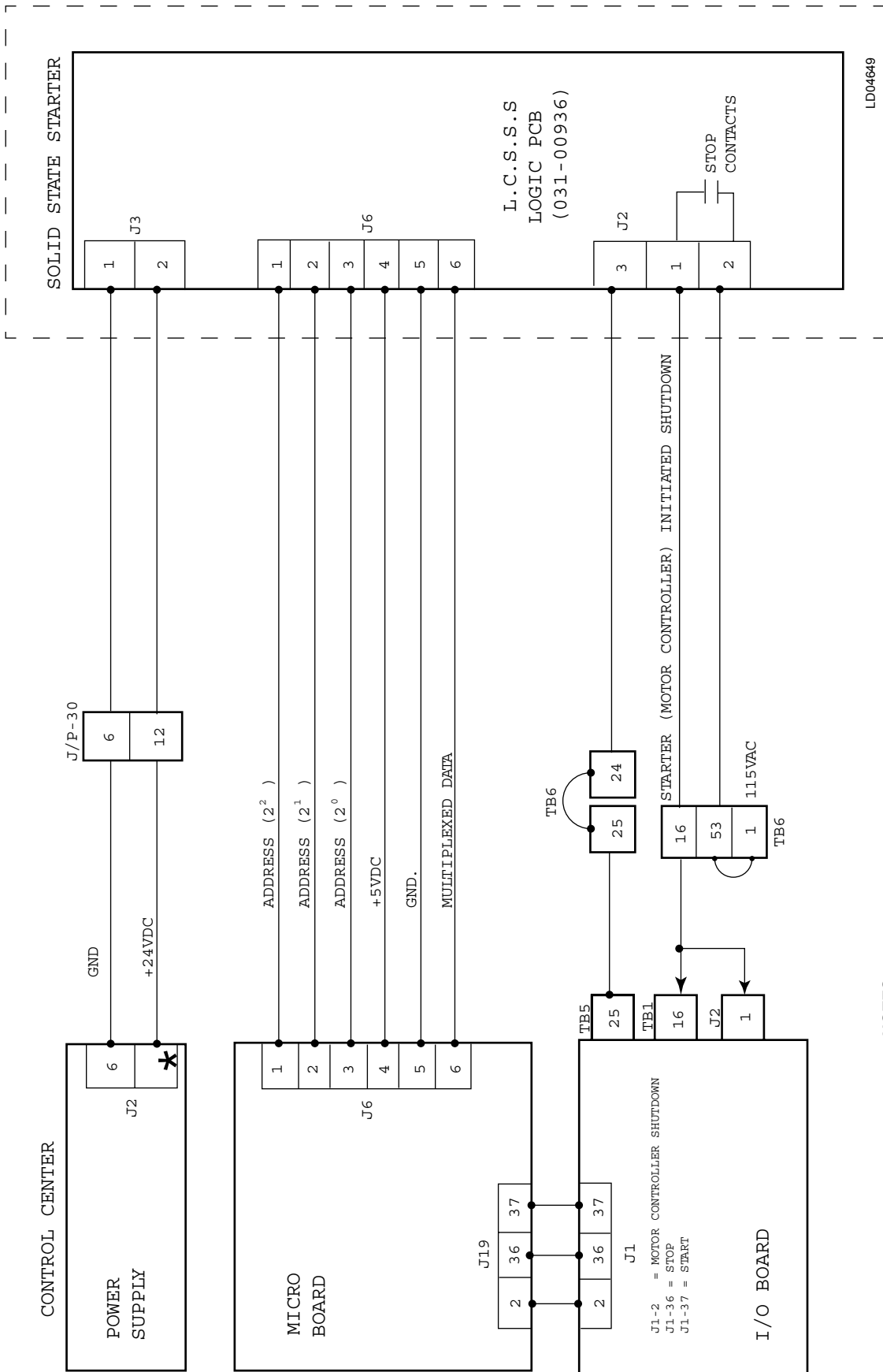

NOTES:

*9_ on "CONDOR" Power Supply

13 on "POWER ONE" Power Supply

FIG. 41 – MOD "A" LIQUID COOLED SOLID STATE STARTER (LCSSS) - INTERFACE

SECTION 12

ADAPTIVE CAPACITY CONTROL BOARD

(REFER TO FIG. 42 - 44)

The optional YORK Variable Speed Drive (refer to manuals 160.00-M1, 160.00-M4) uses an Adaptive Capacity Control (ACC) function to control the speed of the compressor motor. In new production chillers shipped prior to March 2007, this function is performed by the Adaptive Capacity Control Board (031-01782-xxx), which resides inside the Optiview Control Center (refer to fig 43). Prior to June 2006, the COM5 (J15) serial port of Microboard 031-01730-000 (early vintage) or 031- 02430-000 (later vintage) communicates with this ACC Board using YORK protocol (ref FIG. 43). Between June 2006 and March 2007, the ACC board in new production chillers communicate with microboard 031-02430-001 using the same interface/protocol.

On new production chillers after March 2007, the 031-02430-001 microboard COM2 (J13) serial port communicates with the VSD Logic Board 031-02506-xxx using RS-485 Modbus protocol (ref FIG. 43B). Software version C.OPT.01.16.xxx (or later) is required for COM2 Modbus operation. COM2 serial port is selectable between RS-232 and RS-485 operation with program Jumper JP17. It must be positioned on pins 1 & 2 to select RS-485 serial port operation. When using Modbus protocol, the ACC functionality is contained in the 031- 02430-001 microboard and the ACC Board is not used.

To allow microboard 031-02430-001 to be used as service replacement for 031-01730-000 or 031-02430-000 board's non-Modbus applications already in the field, the COM5 serial port is retained on the 031-02430-001 board (ref FIG. 43 & 43A).

With microboard 031-02430-001 and software version C.OPT.01.16.xxx (or later), when “VSD-60Hz” or “VSD-50Hz” is selected on the SETUP Screen, additional Setpoints must be entered on this Screen: The appropriate serial port (COM2-Modbus or COM5-YORK) must be enabled using the “Motor Communications Protocol” Setpoint. The selections are “Modbus or “York”. Microboard 031-02430-001 must be equipped with 128KB BRAM (031-02565-000) to select “Modbus”. If Modbus is selected, the “Motor Node ID” setpoint must be set to match the setting of the VSD Logic Board Modbus Address Switch SW3. They must be both set to “1”.

The 031-002506 VSD Logic Board contains both the Optocoupled YORK protocol serial Port (J11) and an RS-485 Modbus serial port (J16) to allow it to be used as a service replacement part for VSD Logic Board 031-01433-xxx and 031-02077-xxx (ref FIG. 43 & 43A).

With the Medium Voltage VSD (MV VSD), the ACC functionality resides in the 031-02430-001 microboard. The COM2 serial port of this board communicates with the MV VSD using Modbus protocol. Refer to Manual 160.00-M6 for details of the MV VSD.

When the ACC Board is present, this is referred to as the “YORK Protocol Configuration” (FIG 43 & 43A). When the Microboard communicates directly with the VSD logic Board (ACC Board not present), this is the “MODBUS Protocol Configuration” (fig 43B). Software version C.OPT.01.15.307 (and earlier) can only operate in the YORK Protocol configuration. Software version C.OPT.01.16.307 (and later) can be used with either configuration.

YORK Protocol Configuration

The ACC DETAILS Screen displays the pertinent ACC parameters as shown in Operation Manual 160.54-O1 FIG 22A.

The ACC Board performs the following functions:

- Acts as a bi-directional serial communications gateway between the Microboard and the VSD **Logic Board** and VSD **Harmonic Filter Logic Board**.
- Tells the VSD Logic Board at what speed (frequency) to operate the compressor motor. The speed will be the lowest speed between 30 to 60 (50) Hz it can operate without compressor surging.
- Detects Compressor surge conditions.
- Creates a **Surge Map** in battery backed memory by storing the Pre-rotation Vanes (PRV) position, motor speed (frequency) and Evaporator/Condenser pressure differential (head) that exists when each surge occurs.

The VSD consists of a power electronics section, Logic Board and an optional Harmonic Filter with Harmonic Filter Logic Board, all mounted in a cabinet that is either mounted to the compressor motor or floor standing (ret-

rofit applications). The ACC Board is mounted inside the OptiView Control Center. In operation, the VSD Logic Board a.) controls the VSD power electronics to drive the compressor motor at the speed designated by the ACC Board, b.) monitors power electronics parameters and initiates chiller shutdowns when safety thresholds are exceeded and c.) transmits the parameters to the ACC Board for transfer to the Microboard for display. The optional Harmonic Filter reduces the power line harmonics produced by the VSD. The Harmonic Filter Logic Board a.) controls the filter b.) monitors filter parameters and initiates chiller shutdowns when safety thresholds are exceeded and c.) transmits these parameters to the ACC Board for transfer to the Microboard for display. Complete operation and service details of the VSD and ACC Board is contained in YORK manual 160.00-M1 and 160.00-M4.

The Microboard communicates with the ACC Board, VSD Logic Board and the optional Harmonic Filter Logic Board via 0/+5VDC 1200 baud serial communications (FIG. 43). The ACC Board is the center point of communications between the Microboard and the VSD components. The communications is in master/slave form. The VSD Logic Board and Harmonic Filter Logic Boards act as slaves to the ACC and the ACC acts as a slave to the Microboard. The Microboard initiates all communications by sending a command to the ACC Board. The ACC Board passes the command to the VSD Logic Board. The VSD Logic Board responds to the command by returning the requested data to the ACC Board and passes the command to the Harmonic Filter Logic Board. The Harmonic Filter Logic Board returns the requested data to the ACC Board. The ACC Board returns both the VSD Logic Board's response and the Harmonic Filter's response to the Microboard.

There are three different commands issued from the Microboard: **Test and Initialize**, **Fault Data Request** and **Status Data Request**. When power is first applied to the OptiView Control Center, the Microboard establishes serial communications with the ACC, VSD Logic and Harmonic Filter Logic Boards. To establish communications, it sends a Test and Initialize command to the ACC Board, which sends the command on to the VSD Logic Board. The VSD Logic Board relays the command to the Harmonic Filter Logic Board. If the VSD Logic and Harmonic Filter Boards respond appropriately to the ACC Board, the ACC Board responds to the Microboard and communications are established. If any of these boards fail to respond to the first command, the Microboard sends the command again 4 seconds later. It will continue to send this command at 4 second intervals

until a response is received. If, after 10 attempts, no response is received, a Cycling shutdown is performed and **VSD – INITIALIZATION FAULT** is displayed. The Microboard will continue to establish communications until successful. Anytime communications have been established and then lost, the Microboard will repeat this process to re-establish communications.

After communications have been established, the Microboard sends a Fault Data Request command. If there have been any faults detected by the VSD Logic or Harmonic Filter Boards since communications were lost, they are returned to the Microboard at this time. If there is no response within 2 seconds, this command is sent at 2 second intervals until a response is received. If no response is received in 10 attempts, a Cycling shutdown is performed and **VSD – SERIAL COMMUNICATIONS** is displayed.

The Microboard then begins normal communications with the ACC, VSD Logic and Harmonic Filter Boards. During normal communications, commands and data are exchanged every 2 seconds on the serial communications link. The Microboard sends a Status Data Request command every 2 seconds to the ACC Board which is passed along to the VSD Logic Board and Harmonic Filter Logic Boards as described above. It expects to receive the data listed below in response each of these commands. If a response is not received to 10 consecutive commands, a Cycling shutdown is performed and **VSD – SERIAL COMMUNICATIONS** is displayed. The VSD Logic and Harmonic Filter Boards send the data listed below to the ACC Board and the ACC Board adds its data to it and returns all the data to the Microboard in one response. This continues until the VSD Logic or Harmonic Filter Boards detect a fault condition.

As stated above, if communications are lost with the VSD Logic Board, a Cycling shutdown is performed and **VSD – SERIAL COMMUNICATIONS** is displayed. However, if communications are lost with the Harmonic Filter Logic Board, no shutdown is performed, only **WARNING – HARMONIC FILTER – DATA LOSS** is displayed.

When a VSD fault condition is detected, the VSD Logic Board opens its VSD Stop Contacts that are connected in series with the OptiView Control Center's 1R (K18) RUN RELAY coil. This interrupts the circuit to 1R causing it to de-energize, removing the run signal to the VSD. Simultaneously, the Microboard reads the opening of the VSD Stop Contacts via its interface to the OptiView Control Center's I/O Board input J2-1.

This notifies the Microboard that a VSD shutdown has occurred. The Microboard requests the cause of the shutdown by sending a Fault Data Request command. While this request is being processed, the Microboard displays **VSD SHUTDOWN – REQUESTING FAULT DATA**. When the cause of the shutdown is received, the Microboard displays a message describing the shutdown (refer to YORK Operation Manual 160.54-01 for complete listing of messages) and begins sending normal Status Data Request commands. If the fault data is not returned to the Microboard within 2 seconds, it sends the command every 2 seconds until fault data is returned. If none is returned within 10 requests, it assumes it is not forthcoming and displays **VSD – STOP CONTACTS OPEN**.

The following VSD status data is transmitted from the VSD Logic Board to the ACC Board for transfer to the Microboard for display:

- Output Frequency
- Output Voltage
- Output Current - three phase
- Input Power KW
- KWH
- 100% Job FLA
- DC Link Voltage
- DC Link Current
- Internal Ambient Temperature
- Inverter Heatsink Temperature – phase A, B, & C
- Converter Heatsink Temperature
- Pre-charge Relay energized/de-energized
- SCR Gate Drivers enabled/disabled
- Water (cooling) Pump on/off
- VSD running/stopped
- VSD Software version
- Motor HP

The following Harmonic Filter status data is transmitted from the Harmonic Filter Logic Board to the ACC Board for transfer to the Microboard for display:

- Input KVA
- Total Power Factor
- Filter DC Link Voltage
- Input voltage- phase A, B & C
- Input voltage THD – phase A, B & C
- Input Peak voltage – phase A, B & C
- Input Current – phase A, B & C

- Input current TDD – phase A, B & C
- Filter current – phase A, B & C
- Filter Heatsink temperature
- Filter Operation- running/stopped
- Filter Pre-charge relay – energized/de-energized
- Filter Supply Relay - energized/de-energized
- Input Phase Rotation – ABC/CBA
- Harmonic Filter – present/not present

The following ACC status data is transmitted from the ACC Board to the Microboard for display.

- Delta P/P (Head pressure)
- Pre-rotation Vanes position
- Surge count

The compressor motor speed can be controlled either manually in **MANUAL** mode or automatically in **AUTO** mode.

In **MANUAL** speed control mode, the speed can be controlled from the **VSD Tuning** Screen using Keypad keys. The speed can be set to a pre-selected frequency over the range of 10 to 60 (50) Hz. Or, it can be increased or decreased over the range of 0.0 to 60 (50) Hz in increments of 0.1 to 10 Hz. Instructions for manual control are included in the “System Calibration, Service Setpoints and Reset Procedures” section of this book. With software version C.OPT.01.19.307 (and later), this is displayed as “Speed Command” on the VSD TUNING Screen and ACC DETAILS Screen. Via Serial communications, the speed command is sent from the Microboard to the ACC Board, where it is passed on to the VSD Logic Board. The VSD Logic Board controls the VSD to operate the motor at this frequency. While Manual control is selected, **VALID POINT LED CR8** is illuminated, indicating that surges will not be mapped in the Surge Map. Anytime this LED is illuminated, surges are not mapped, as explained below. In making the transition from Manual to Auto mode, if the speed was manually set to <30 Hz, it will automatically be set to 30 Hz and automatically adjusted from this value. If not in Current Limit and the actual speed is <60 (50) Hz, and 60 (50) Hz is selected, the speed will be increased as follows. If the Leaving Chilled Liquid temperature is within 0.2°F, the PRV will simultaneously be driven closed per the following:

Speed Increase

- 0.2 Hz every second if Leaving Chilled Liquid Temperature >0.2°F below the Setpoint and motor current is <80%FLA.

- 0.2 Hz every 1 + (%FLA-80) second if Leaving Chilled Liquid Temperature is $>0.2^{\circ}\text{F}$ below the Setpoint and the motor current is $>80\%$ but $<98\%$ FLA.
- 0.2 Hz every 19 seconds if none of the above conditions are present.

PRV Close

A close signal of the following durations is applied every 4.5 seconds:

- 3.9 seconds if PRV position $>50\%$.
- 3.0 seconds if PRV position $>25\%$ but $<50\%$.
- 1.5 seconds if PRV position $<25\%$.

In **AUTO** speed control mode, the ACC Board controls the speed. It determines the optimum compressor motor speed (frequency) over the range of 30 to 60(50) Hz and sends this value to the VSD Logic Board via the Serial communications link. The VSD logic Board controls the VSD to operate the motor at this frequency. The optimum speed is the slowest speed possible that will avoid compressor surge conditions but still allow the chiller to meet capacity requirements. This speed is found in an adaptive sense as explained below.

In determining the optimum motor speed, the ACC Board employs the following:

- **Delta P/P** – This is the chiller Head pressure. It is calculated as (Condenser pressure – Evaporator pressure) / Evaporator pressure. It ranges from 0.00 to 3.60. The ACC Board calculates this value from evaporator and condenser pressure values received from the Microboard via serial communications link. The ACC Board returns the calculated Delta P/P value to the Microboard for display over the same link.
- **Pre-rotation Vanes (PRV) position** – The Pre-rotation vanes position, as used by the VSD control, is provided by a Potentiometer mounted to the PRV control arm. The potentiometer interface varies according to whether or not the ACC Board is used. In YORK Protocol configuration, it is connected to the ACC Board (fig 43 & 43A).

In MODBUS Protocol configuration, it is connected to the microboard (fig 43B).

The PRV position (0-100%) is displayed on the OptiView display as 0% when fully closed, 100 % when fully open and whole percentage points in between.

The potentiometer must be calibrated by a qualified Service technician using a procedure in the “System Calibration, Service setpoints and Reset Procedures” section of this book. No speed reduction is permitted if this calibration has not been performed.

- **Motor Speed** – This is the actual drive frequency of 30 to 60(50) Hz.
- **Surge Map** – This contains the Delta P/P, PRV position and motor speed that existed at the instant of each previously encountered surge condition. These parameters are stored as a 3-dimensional array for each surge. The surge map is stored in the ACC Board’s BRAM battery backed memory. The following procedures are detailed in the “System Calibration, Service Setpoints and Reset Procedures” section of this book: The entire Surge Map can be printed by pressing the “Surge Map Print” keypad key. Surge Map points can be automatically printed to an external printer as they are plotted. The Surge Map can be cleared.



The Surge Map must never be cleared unless advised by the YORK Factory.

The following conditions must be met before speed reduction is permitted:

- The PRV calibration procedure must have been performed.
- **Auto** speed control mode must be selected at the Keypad.
- Current Limit must not be in effect. When current limit is in effect, Valid Point LED CR8 is illuminated.
- The Chiller must have been running for >2 minutes.
- The Leaving Chilled Liquid Temperature must be within $+0.3$ and -0.6°F of the Leaving Chilled Liquid Setpoint. The Leaving Chilled Liquid temperature must be stable. Lowering the speed while this temperature is unstable, would tend to increase the instability. The Microboard calculates the stability by comparing the Leaving Chilled Liquid Temperature to the Leaving Chilled Liquid Temperature Setpoint to arrive at a rate of change value.
- Certain applications, such as short chilled liquid loops, multi-pass evaporators, parallel chillers

and light load conditions can cause excessive Pre-rotation Vane (PRV) movement resulting in leaving chilled liquid temperature control instability. This instability can be reduced by adjusting the SENSITIVITY Setpoint on the OptiView Evaporator Screen. The 50% selection reduces the magnitude of PRV movement over the NORMAL selection and the 30% selection reduces it even more. With Flash Memory Card version C.MLM.01.06.xxx and later or “P” compressors with C.MLM.04.02.xxx and later, and the 50% or 30% sensitivity is selected, PRV movement is further reduced during low load conditions with variable speed drive as follows: When the PRV position is < 25% and the Leaving Chilled Liquid Temperature is within ± 2.5 °F of Setpoint, the maximum allowed vane pulse is limited to 3.5 seconds at the 25% PRV position and 0.9 seconds at 0% position. PRV positions in between have linearly scaled maximums.

When the chiller is started, the speed is brought to 60 Hz. After it has been running for >2 minutes and the Leaving Chilled Liquid Temperature is within +0.3 and -0.6°F of the Leaving Chilled Liquid Temperature Setpoint, the ACC Board evaluates if the speed can be reduced. If there are no conditions above that would inhibit speed reduction, the ACC Board compares the real-time Delta P/P, PRV Position and motor speed to the 3-dimensional arrays stored in the **Surge Map**. If the real-time array does not match any previous surge condition, the speed will be decreased 0.1 Hz every 6 seconds until it is within 1 Hz of previously plotted surge condition array in the Surge Map. It will then be decreased 0.1 Hz every 9 seconds until it's to the lowest value allowed by the Surge Map. If no plotted points are encountered, the speed is lowered until a surge is encountered or a minimum of 30 Hz is reached.

The ACC Board uses two different methods of **Surge Detection**; Delta P method and DC Link method. Surge detection is only enabled while the chiller is running. In detecting a surge using the Delta P method, the outputs of the Evaporator and Condenser pressure Transducers are monitored to detect when the difference between these pressures (Delta P) drops transiently toward Zero. This would be indicative of a surge. A surge detected by the Delta P method must have all of the following conditions occur within 5 seconds to be considered a valid surge: a.) Delta P must make a negative transition and exceed 3.4 PSIG for 100 Milliseconds. B.) Delta P must also exceed 3.5 PSIG for at least 340 milliseconds. C.) Delta P must make at least 2 positive transitions. When this criteria is met, **Surge LED CR9** illuminates for 2 seconds, in-

dicating a valid surge has been detected. In detecting a surge using the **DC Link** method, the VSD's DC Link Current is monitored to detect when the current drops transiently toward zero. This, as the case with Delta P method, is indicative of a surge. A surge detected by this method must also meet the following requirements to be considered a valid surge: a.) At least 6 **DC Link** surges must occur within 2 minutes, and b.) At least 3 **Delta P** surges have occurred within the 2 minute interval. When both these criteria have been met, **Surge LED CR9** illuminates for 2 seconds, indicating a valid surge has been detected. The value displayed as “ACC Surge Count” on the ACC DETAILS Screen is provided by the ACC Board. Each time the ACC Board detects a surge, the ACC Board increments the count, whether running at maximum or less than maximum frequency.

Each time a Valid Surge is detected, the ACC Board increases the motor speed (up to a maximum of 60(50) HZ) to take the compressor out of surge. It also evaluates other chiller conditions to determine if the surge should be plotted on the **Surge Map**. Surges that occur during certain operating conditions are not plotted, as explained below. Whenever **Valid Point LED CR8** is illuminated, surges are not plotted.

After each surge, the speed is increased either 1.0 Hz or 0.8 Hz, depending on operating conditions, in the following increments:

- 0.1 Hz every 2 seconds if motor current <80%FLA.
- 0.1 Hz every 2 + (%FLA-80) if motor current >80%FLA but <98%FLA.
- 0.1 Hz every 20 seconds if motor current >98%FLA.

If Current Limit is in effect, or the Stability Timer is running when a surge occurs, the speed is increased 1.0 Hz but the surge is not plotted on the Surge Map since these conditions would produce an erroneous value. Valid Point LED CR8 is illuminated as a visual indication that one or both of these conditions are in effect.

Otherwise, the speed is increased 0.8 Hz and the surge event is plotted on the **Surge Map**. The Surge Margin Adjust Setpoint can be used to add an extra margin of surge prevention. It is programmed over the range of 0.0 to 25.0 Hz following instructions in the “System Calibration, Service Setpoints and Reset Procedures” section of this book. The Default value of 0 should provide proper operation in most applications.

When the speed has been increased either 1.0 Hz or 0.8 Hz, as described above, this speed is maintained for the next 15 seconds. During this period, new surges are ignored. When the 15 seconds have elapsed, a 5 minute time period is entered where the speed is inhibited from decreasing, but increases are allowed. If a surge is detected within this 5 minute period, it is not plotted on the Surge Map, but the speed is increased by the amount as described above. This is repeated as long as the compressor continues to surge. The compressor must be surge free for 5 minutes before a speed decrease is permitted or another surge or another surge can be plotted on the Surge map.

The ACC Board counts the surges as they occur and sends a total count to the Microboard for display on the ACC Details Screen (note that the Total Surge Count displayed on the Surge Protection Screen and the Hot Gas Bypass Screen is that which is accumulated by the Surge Protection feature). The total surge count is not incremented if a different surge type occurs within 10 seconds of the previous surge. A Surge that occurs within 10 seconds of the previous surge is only counted if it is of the same surge type. For example, if a **Delta P** surge is detected and a **DC Link** surge is detected within 10 seconds, the **DC Link** surge is not counted. If the **DC Link** surge occurred >10 seconds after the **Delta P** surge, it would be counted.

A surge point can be manually inserted into the Surge Map using the **Manual Surge Point** keypad key on the **ACC Details** screen and switch SW1 on the ACC Board as described in the “System Calibration, Service Setpoints, and Reset Procedures” section of this book. This is only to be used for situations in which the automatic surge detection described above does not respond to surge events. This is usually not required and is to be used only by qualified Service Technicians as a method of plotting a surge event that the ACC Board does not find on its own. At the instant the condition is identified as a surge event, **Surge LED CR9** illuminates for 2 seconds. The motor speed, Delta P/P and PRV Position at the instant the point is established, is unconditionally plotted as a 3-dimensional array in the Surge Map as a surge condition, regardless of whether or not **Valid Point LED CR8** is illuminated. The motor speed will be automatically increased as described above. Once plotted, the ACC Board will respond to this point in exactly the same way it responds to automatically plotted surge points, as described above.

Surge points can be printed from the **ACC Details** Screen. The entire stored Surge Map can be printed using the **Surge Map Print** keypad key. Also, the surge points can be printed in real-time as they occur, using the **Auto Print** keypad key. Since the maximum rate at which new surges can be plotted is every five minutes, the rate at which new points are printed is also every five minutes.

When the PRV's approach their 100% open position, there is very little PRV movement remaining to compensate for an increasing load condition. Therefore, in **Auto** speed control mode, if there is no Current Limit in effect, and the PRV position reaches >98%, the speed is automatically increased at a rate based on the Delta T between the Leaving Chilled Liquid temperature and the Leaving Chilled Liquid temperature Setpoint as follows:

- 0.1 Hz every 10 seconds if Delta T is >0.2 and <0.5°F.
- 0.1 Hz every 8 seconds if Delta T is >0.5 and <0.9°F.
- 0.1 Hz every 6 seconds if Delta T is >0.9°F.

If **Delta P/P** ever increases to >3.60, the speed will be slowly increased to 60 Hz. If this were to occur, **Delta P/P** would have to decrease to <3.55 before a speed decrease would be allowed.

The microprocessor is the center point of the hardware architecture (FIG. 42). It coordinates the serial data communications between the OptiView Control Center Microboard and the VSD Logic Board and Harmonic Filter Logic Board. This serial data is in 0v/+5VDC form. YM XMT (CR7) and YM RCV (CR6) LED's illuminate during serial communications with the OptiView Control Center Microboard. Similarly, VS XMT (CR5) and VS RCV (CR4) LED's illuminate during serial communications with the VSD Logic Board. Serial communications with the Harmonic Filter logic Board take place through the microprocessor via the Digital Signal Processor. This data is accompanied by a Framing pulse and a CLK signal. Although Evaporator and Condenser pressures are transmitted to the ACC Board via the serial communications link for **Delta P/P** calculation, these pressures are also applied directly from the Microboard to the **MUX** (multiplexer) for **Delta P** surge detection.

Also applied to the MUX, is the output of the PRV position Potentiometer. Under program control, these values are input to the microprocessor. The EPROM contains the operating Program for the ACC Board. The

RAM serves as the scratch pad memory. The BRAM is a battery backed memory device where the Surge Map is stored. The Watchdog circuit maintains the microprocessor in a reset state during low voltage conditions. This prevents the microprocessor from reading/writing or processing data until it and supporting circuits have sufficient supply voltage. The Watchdog also assures that the entire Program is executed and that no Program latch-ups occur. **Surge LED CR9** illuminates for 2 seconds when a valid surge condition has been detected as explained above. **Valid Point LED CR8** illuminates whenever there is a condition in effect that prevents a Surge from being plotted on the **Surge Map**. These conditions are: a.) Current Limit is in effect b.) Leaving Chilled Liquid Temperature Stability Timer is running, indicating an unstable control condition c.) Speed control is in **MANUAL** mode. Switch SW1 is used to manually insert (plot) a surge point in the **Surge Map**.

Test points are provided as follows:

- TPA: +5VDC supply voltage.
- TPB: supply voltage ground.
- TPC: Watchdog power failure detected. Normally >+4.5VDC. Transitions to logic low (<3.5VDC) during low voltage conditions.
- TPD: Harmonic Filter Logic Board 0/+5VDC 1200 baud serial data.
- TPE: Harmonic Filter Logic Board Frame pulse.

MODBUS Protocol Configuration

In MODBUS Protocol configuration (Microboard 031-02430-001 with software version C.OPT.01.16.307 and later), the ACC function is in the Microboard and the ACC Board is not present. The Microboard communicates directly with the VSD Logic Board through the Modbus serial communications (ref fig 43B). All the commands to the VSD and data from the VSD are via this communications link. Generally, the serial communications and data transfer and shutdown status is as described in “YORK protocol configuration” above.

The ACC DETAILS Screen displays the pertinent ACC parameters as shown in Operation manual 160.54-01 FIG. 22B (Software version C.OPT.01.19.307 and later provides the parameters in this description). The ACC function in the Microboard performs the ACC surge detection. ACC surges are detected only when the drive is running at less than maximum frequency. With software version C.OPT.01.19.307 (and later), the surge detection and reaction routine is disabled until 5 seconds after the

start frequency (25Hz for 50Hz applications/30Hz for 60Hz applications) is achieved. This prevents false surge conditions from being logged or reacted to.

The VSD START FREQUENCY setpoint (software version C.OPT.01.21.307 and later) allows the Service Technician to enter the starting frequency from which the speed ramp-up will begin. This setpoint is programmable over the following range:

- a. 60Hz units – 30Hz to 60Hz (default 45Hz)
- b. 60Hz units with Quick Restart- 30Hz to 45Hz (default 45Hz)
- c. 50Hz units – 25Hz to 50Hz (default 37.5 Hz)
- d. 50Hz units with Quick Restart – 25Hz to 37.5Hz (default 37.5Hz)

The “Surge Sensitivity” Setpoint is used to adjust the sensitivity of the ACC surge detection. It is programmable over the range of 1.5 to 2.5 (default 2.0); smaller values increase the sensitivity. Whenever an ACC surge is detected, the “ACC Surge detected” LED momentarily illuminates and the “ACC Surge Count” increments (The “Surge Avoidance Surge Detected” LED is shown for reference only. It momentarily illuminates when the Surge Protection feature (see section 22) detects a surge. These are only those surges that occur while the drive is running at maximum frequency. This LED should not be confused with ACC detected surge events).

The ACC Mapping Enable Setpoint (0.5°F to 4.0°F; default 1.0°F)(software version C.OPT.01.21.307 and later) allows the Service Technician to set the Delta T (Leaving Chilled Liquid Temperature - Setpoint) needed to be met to enable surge mapping and speed reduction initially on startup.

Software version C.OPT.01.19.307 (and later) has increased noise filtering on the surge detection. Valid ACC surge points are stored in the Surge Map in the microboard BRAM, as displayed on the SURGE MAP Screen (see below). “Surge Map Point Count” displays the total number of data points contained in the surge map. Based on this surge detection, the speed command is sent to the VSD Logic Board and displayed on the ACC DETAILS Screen as “Command Frequency”. The “Speed Decrease Inhibit – Surge Map point” LED illuminates when the speed cannot be reduced due to a mapped point. The “Mapping Inhibited” LED illuminates while a point is not allowed to be mapped (not allowed to slow down as well) due to unstable leaving chilled liquid temperature, manual speed control or current limit in effect.

With software version C.OPT.01.21.307 (and later), Surge Mapping is inhibited while a Soft Shutdown is in effect. In software versions C.OPT.01.20.307 (and earlier), if 2 surges are detected during the initial ramp (ramp towards max frequency after reaching start frequency), the command frequency is set to the max frequency regardless of motor current. This can result in motor current rising sharply and forcing vanes to have to close hard and even possibly a trip on high current or overload. In software version C.OPT.01.21.307 (and later), for every 2 surges that are detected during the initial ramp, increase the command frequency (no higher than the maximum frequency) by the amount listed in the following table. After increasing the command frequency, the initial ramp surge count is reset so it can react to another 2 surges and the initial ramp shall be continued. This logic shall be in effect during the entire initial ramp and take action as many times as necessary.

Frequency Command Increase	Motor Current
1 Hz	> 90% FLA
1.5 Hz	> 75% FLA
2 Hz	> 60% FLA
4 Hz	<= 60% FLA

The Pre-rotation vanes position potentiometer is connected to the Microboard (see fig 43B). It must be calibrated by Service Technician using the procedure in Section 23 of this book.

With software version C.OPT.01.19.307 (and later), to assure that frequency increases do not cause excessive motor current resulting in overload shutdowns, frequency increase limitations are imposed based upon how close the actual motor current is to the chiller full load amps. In Automatic Frequency Control mode, anytime the microboard ACC function increases the VSD or MV VSD output frequency, the frequency increase is limited by the motor current as follows. Although the incremental frequency increases can be less than allowed, they will never be greater than allowed. These limitations also apply to the frequency ramp that occurs at chiller start while ramping from start frequency 30Hz (60Hz applications) or 25Hz (50Hz applications) to maximum frequency. These limitations are not imposed in Manual Frequency Control:

- When Motor Current <= 80% FLA: No Limiting
- When Motor Current > 80% FLA and <=98% FLA: Increase 0.1Hz every {2 + (%FLA-80)} seconds
- When Motor Current > 98% FLA: Increase 0.1Hz every 20 seconds

With software version C.OPT.01.21.307 (and later) if motor current is >= 101 %FLA, the VSD speed command is decreased 0.1 Hz every 3.0 seconds until the motor current < 101 %FLA. The surge map takes priority over current limiting. Thus if there is a mapped surge point in the present sector, ACC current limiting shall not be allowed to decrease the frequency below the mapped point.

In previous software versions, the initial ramp is complete when either of the following conditions occur:

- Delta T < ACC Mapping Enable
- VSD Speed Command = Maximum

In this version, the initial ramp will be complete when any of the following occur:

- Delta T < ACC Mapping Enable
- VSD Speed Command = Maximum
- Motor Current >= 100 %FLA

When the VSD initiates a fault shutdown, it opens the VSD Stop Contacts on the VSD Logic Board, notifying the Microboard as described above in “YORK protocol configuration” above.

The SURGE MAP Screen displays the surge map in either TABLE or LIST form, as shown in Operation Manual 160.54-O1 figure 22C and 22D. When set to TABLE, the map is shown graphically. The X-axis is Delta P/P and the Y-axis is PRV position. Each VSD frequency point is represented by an “X” in the table. The Present Operating conditions are indicated with an “*” and are detailed at the bottom of the screen under PRESENT.

If the present condition is the same as a mapped point, the “*” will be replaced by an “O”. To view the details of any mapped point, position the green box (□) over the desired “X” using the keypad arrow keys (▲▼◀▶). The VSD Output Frequency, Pre-rotation Vanes Position and Delta P/P of the selected point is displayed at the bottom of the screen under SELECTED. Surge points can be inserted manually using the MANUAL SURGE POINT key, while the chiller is running. They can be deleted manually using the REMOVE SURGE POINT key by positioning the green box over the desired “X”.

When set to LIST, the Delta P/P, PRV Position and VSD Output Frequency of each mapped point are listed in rows. This is the same report that is generated when the surge map is sent to a printer. The PAGE UP and PAGE DOWN keys are used to scroll to the previous or next listing.

are presently set to 7000. If a new version of software were installed in a chiller with Stability Limit set below 7000, the old value would be retained. The only way to clear it would be to clear the BRAM. To prevent this from happening, this value is no longer programmable. It is now always set to 7000.

The Stability Limit programming button was removed from the ACC Details Screen in a previous software version. The Stability Limit default and maximum values

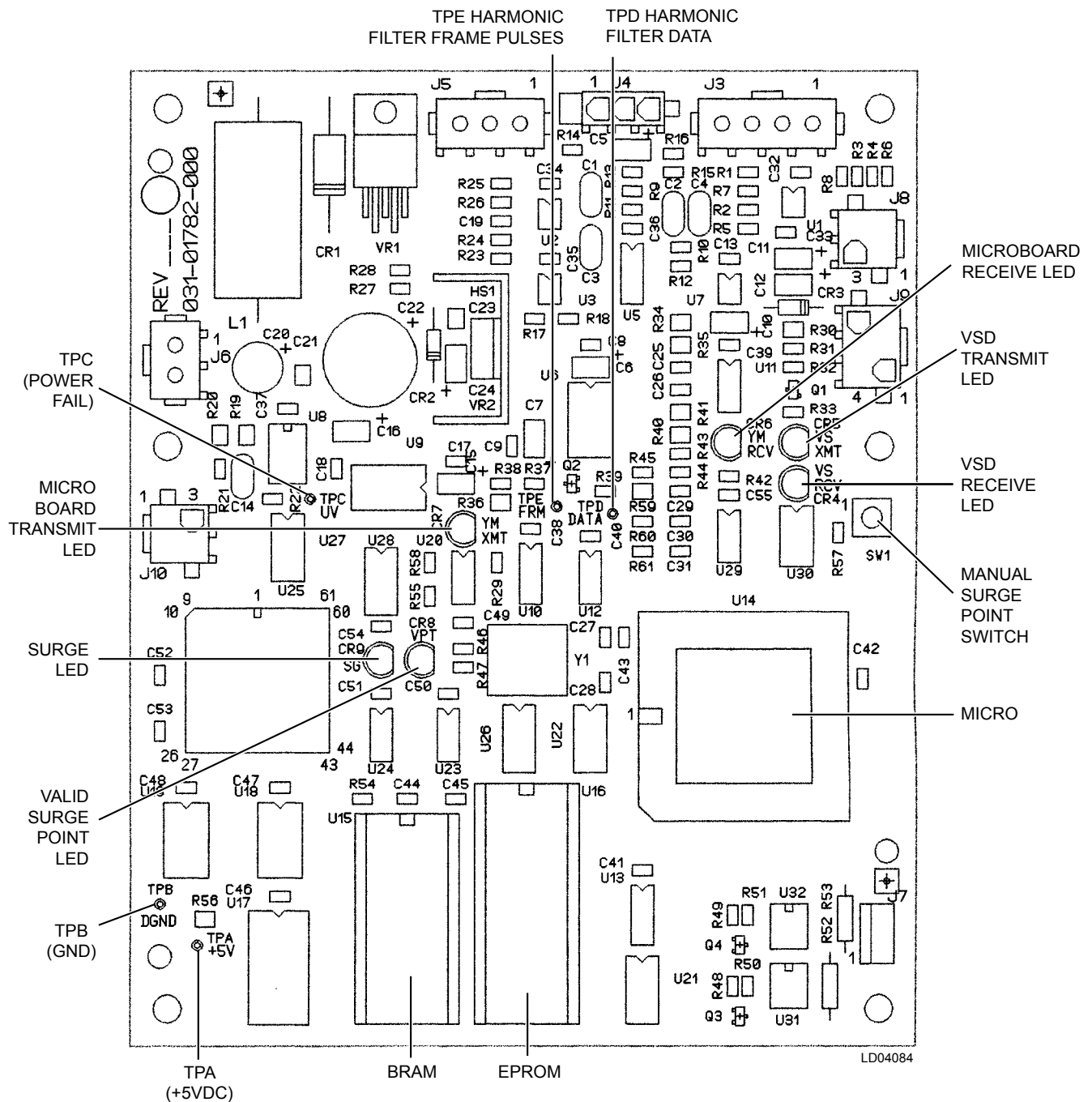
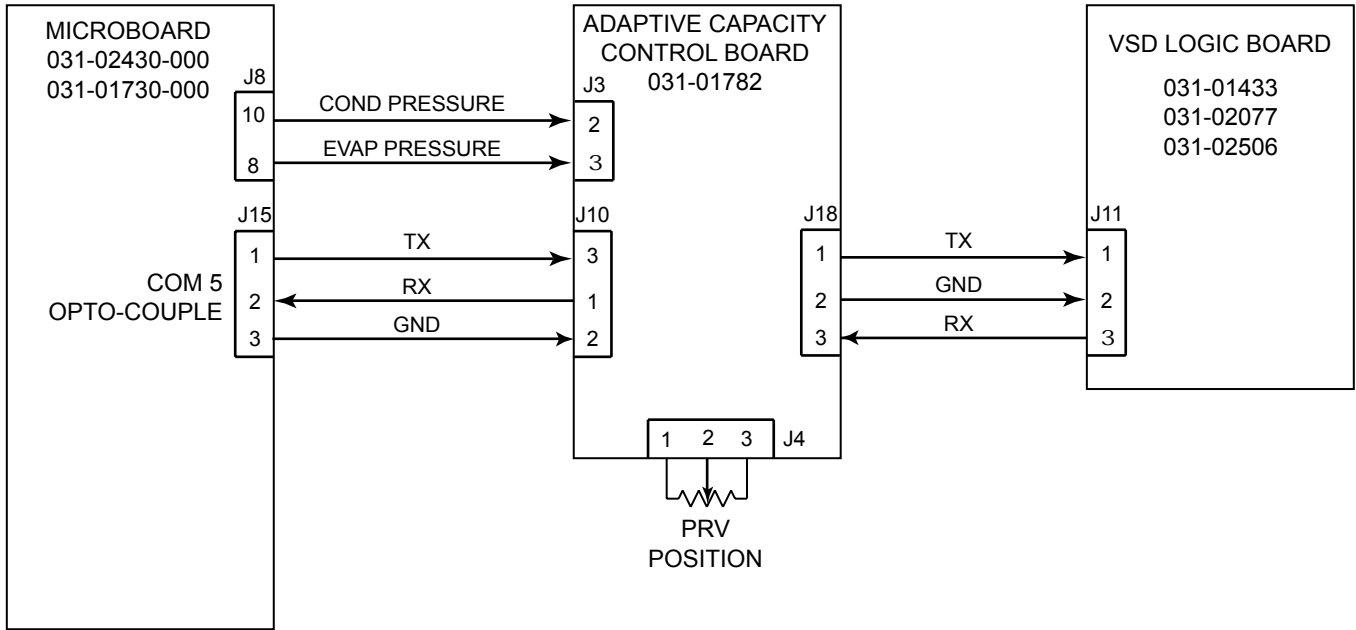
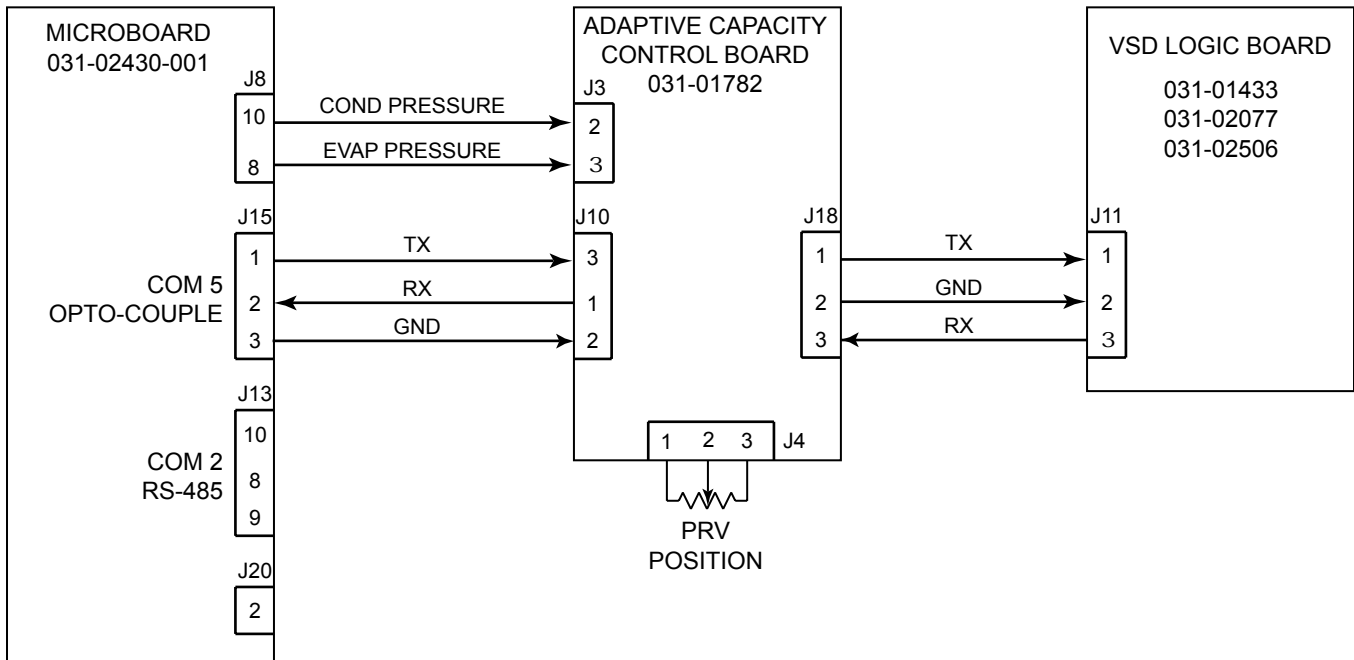

FIG. 42 – COMPRESSOR MOTOR VARIABLE SPEED DRIVE (VSD) ADAPTIVE CAPACITY CONTROL (ACC) BOARD



LD12567

FIG. 43 – SERIAL COMMUNICATIONS INTERFACE - YORK PROTOCOL



LD12568

FIG. 43A – SERIAL COMMUNICATIONS INTERFACE - YORK PROTOCOL

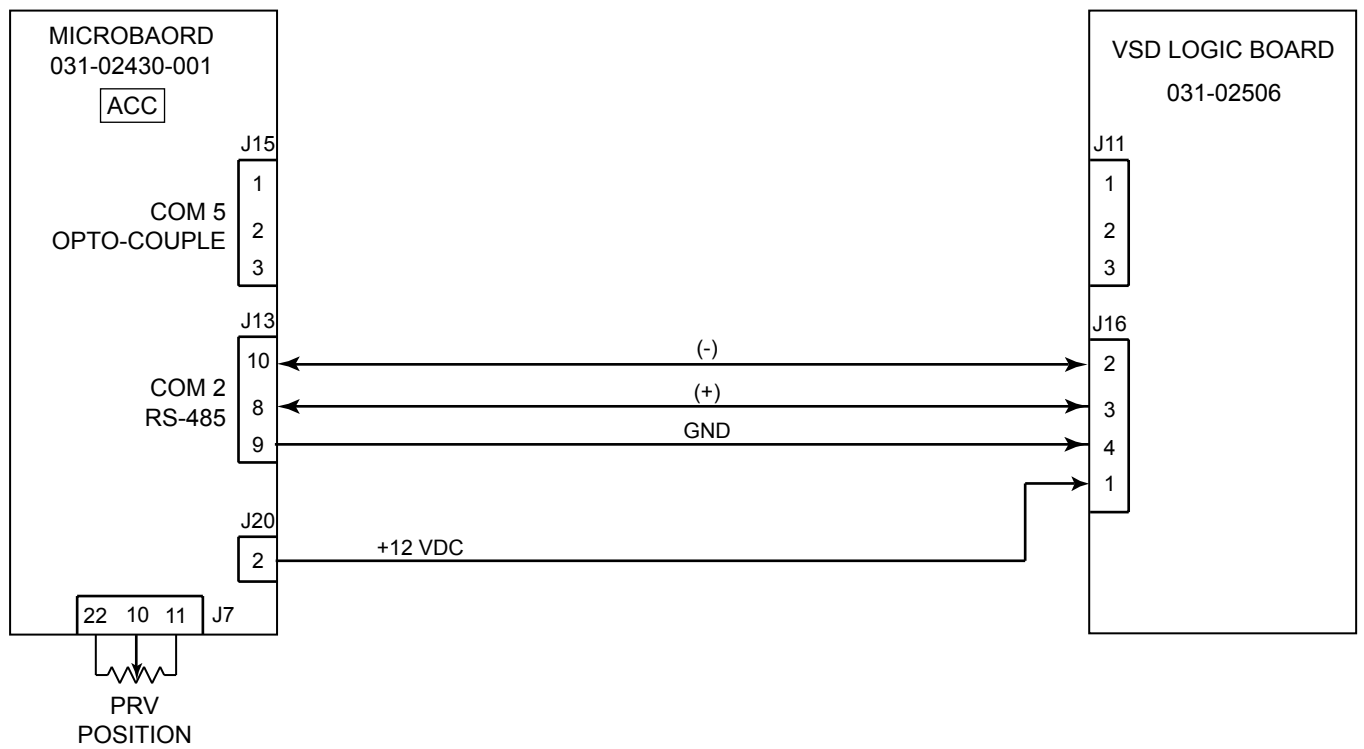

LD12569

FIG. 43B – SERIAL COMMUNICATIONS INTERFACE - MODBUS PROTOCOL

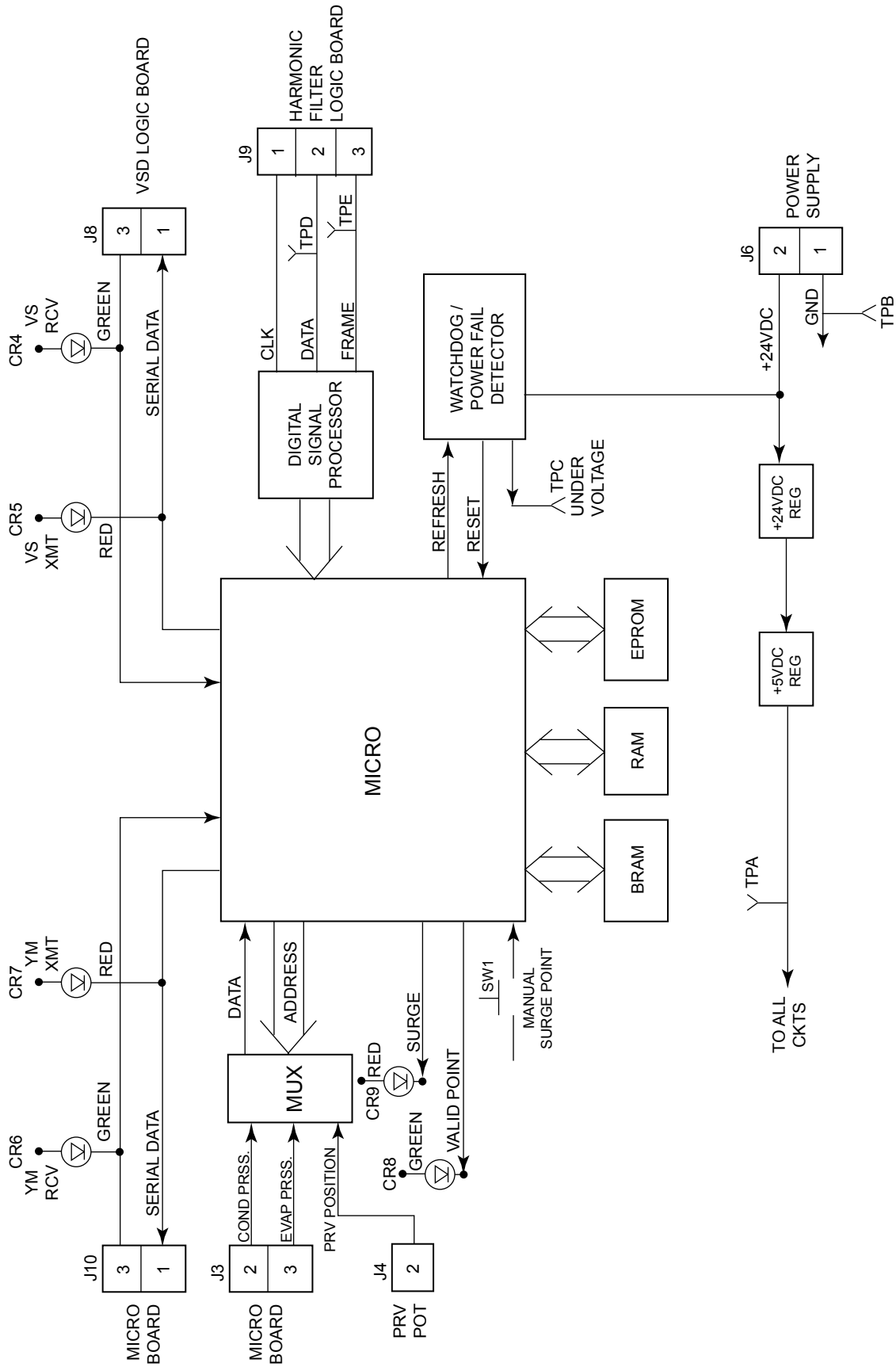

LD04086

FIG. 44 – ADAPTIVE CAPACITY CONTROL (ACC) BOARD

SECTION 13 PROXIMITY PROBE

(REFER TO FIG. 45 - 48)

The following applies to all applications except “P” compressors and style F and later chillers with “G, Q” or “H5-8” compressors. For chillers equipped with “P” compressors, refer to Section 13A: The Proximity Probe senses the distance between the tip of the Proximity Probe and the surface of the High Speed Thrust collar. An earlier vintage Probe (025-30961-000) also sensed the High Speed Drain Line oil temperature. However, regardless of which Probe is installed, chillers equipped with Flash Memory Card version C.MLM.01.03 or later do not sense the High Speed Drain Line oil temperature. The different vintages of Proximity Probes are shown at the end of this section.

The output of the Proximity circuit is connected to the Microboard at J8-15 and is a 0 (0.089VDC) to +4.4VDC analog voltage corresponding to a measured distance of 10 to 99 mils. This is the **PROXIMITY POSITION** and is displayed as “High Speed Thrust Bearing Proximity Position = xx mils” on the Proximity Probe Calibration Screen. The output of the 025-30961-000 Probe Temperature circuit is connected to the Microboard at J8-1 and is a 0 to +4.5VDC analog voltage corresponding to a measured temperature of 0°F (-177°C) to 300°F (148.9°C). This is the **OIL DRAIN LINE TEMPERATURE** and is displayed as “High Speed Thrust Bearing Oil Drain Temperature = xxx°F on the Compressor Screen (not applicable to Flash Memory Card version C.MLM.01.03 or later).

When the Probe is installed at the time of chiller manufacture, a reference position is established. It is the distance between the tip of the Probe and the surface of the High Speed Thrust Collar with a minimum of 25 PSID oil pressure. Any distance between 37 and 79 mils is acceptable. It is established using a calibration procedure in the “System Calibration” section of this book. This value is entered at the Keypad as the **REFERENCE POSITION** Setpoint using the Proximity Probe Calibration Screen. Distances outside the range of 37 to 79 mils will be rejected. The value is logged on a label adhered to the inside of the OptiView Control Center door. This value remains the Reference Position until the compressor is rebuilt, whereupon the calibration procedure must be repeated to establish a new Reference Position. Since this Reference Position value is stored in the BRAM (U52) memory device on the Microboard, field replacement of either of these items requires the Reference Position Setpoint to be programmed again.

The difference between the Reference Position and the actual Position is the **PROXIMITY DIFFERENTIAL** and is displayed as “High Speed Thrust Bearing Proximity Differential = xx mils” on the Compressor Screen. For example, if the Reference Position is 50 mils and the actual Position is 45 mils, then the Differential is -5 mils; with the same Reference, if the actual Position is 55 mils, the Differential is +5 mils.

If the Differential increases to ≥ 10 mils (+10, +11, etc.) or decreases to ≥ 25 mils (-25, -26, etc.), a Safety shutdown is performed and “THRUST BEARING - PROXIMITY PROBE CLEARANCE” is displayed. With software version C.MLM.01.10.xxx (and later) or C.OPT.01.10.302 (and later), the clearance is only checked during the last 20 seconds of “System Prelube”, during “System Run” and during “Coastdown”. Therefore, the fault is only detected during those periods. With all previous software versions, the clearance is continually checked. The -25 threshold must be exceeded for 2 continuous seconds to initiate a shutdown. The amount of time the +10 threshold has to be exceeded is dependent upon the software version. With software version C.MLM.01.10.xxx (and later) or C.OPT.01.10.302 (and later), the +10 threshold must be exceeded for 2 continuous seconds to initiate a shutdown. With all previous software, the +10 threshold only has to be exceeded for an instant to initiate a shutdown.

If the Reference Position is between 37 and 46 mils, the full -25 mil differential is not allowed; the maximum allowed distance between the tip of the Probe and the surface of the Thrust Collar is 23 mils. Therefore, when the distance decreases to ≤ 22 mils, the Safety shutdown is performed, regardless of the Differential to the Reference Position.

If the distance decreases to ≤ -17 mils, a safety shutdown is performed and “THRUST BEARING - PROXIMITY PROBE OUT OF RANGE” is displayed.

On chillers equipped with Probe 025-30961-000 and Flash Memory Card version C.MLM.01.02 and earlier, if the Drain Line Temperature increases to $\geq 250.0^\circ\text{F}$ (121.1°C), a Safety shutdown is performed and “THRUST BEARING - HIGH OIL TEMPERATURE” is displayed. If the Temperature signal output of the Probe decreases to 0VDC, it is indicative of an

open circuit or a broken wire to the Probe and a Safety shutdown is initiated and “THRUST BEARING - OIL TEMPERATURE SENSOR” is displayed.

When any of the above Thrust Bearing related Safety shutdowns occur, the chiller cannot be restarted until a special reset procedure is performed by a Service technician. Some of these shutdowns also require a thrust bearing inspection. The reset procedure and bearing inspection criteria is listed in the “System Calibration, Service Setpoints and Reset Procedures” section of this book.

The Proximity Position output of the Probe is measured at the Microboard at J8-15 and is calculated as follows:

$$V = \frac{D - 8.14}{20.86}$$

$$D = 20.86 \times V + 8.14$$

Where: V = VDC
D = distance in Mils

The High Speed Drain Temperature output of Probe 025-30961-000 is measured at the Microboard at J8-1 and is calculated as follows:

$$V = \frac{T - 18.75}{62.5}$$

$$T = 62.5 \times V + 18.75$$

Where: V = VDC
T = Temp in Deg F

The chiller could be equipped with one of several different

Probes. The Probe differences vary with the vintage. The differences are listed below. For service replacement, refer to part number listed in renewal Parts 160.54-RP1 and 160.73-RP3.

For microboard 031-01730-000, microboard program jumpers JP41 and JP42 must be positioned appropriately to provide proper operation of actual probe installed. Refer to Table 1, Microboard Program Jumpers.

The Probe cannot accurately measure the gap distance if its supply voltage, +24VDC, decreases to <19.0VDC. To prevent an invalid Proximity gap Safety shutdown due to a Utility Power sag, the Microboard monitors the Probe's 24VDC power source at J9-12 on the Microboard. If it decreases to <19.0VDC, a Cycling shutdown is performed and “Proximity Probe - Low Supply Voltage” is displayed. The chiller will automatically restart when the voltage increases above +19.7VDC.

IMPORTANT! Probes 025-35900-000, 025-35900-001 and 025-40496-000 do not sense the High Speed Drain Temperature. The value returned from the Probe for this temperature will be 0Vdc. If the software reads this value, the 0Vdc value will cause the chiller will be locked out on the safety “THRUST BEARING – OIL TEMPERATURE SENSOR” (complete explanation of this message is in Operation Manual 160.54-O1). Therefore, the software used must be of a later vintage that does not read this parameter. For microboards 031-01730-000, Software versions C.MLM.01.03 (and later) do not read this parameter and are required for these probes. If the software does not meet this requirement, a new Flash Card (031-01797) must be ordered at the same time as the probe. For microboards 031-02430-000/001, all versions of software do not read this input and therefore meet this requirement.

<u>Part Number</u>	<u>Supply Voltage</u>	<u>Description</u>
025-30961-000	+24VDC, +5VDC	Production until April 2000. Senses Proximity. Also senses High Speed Drain Line Oil Temperature unless equipped with Flash memory card version C.MLM.01.03 or later. 1-piece integrated design that includes the electronics in the barrel of the probe. Refer to FIG. 45.
025-35900-000	+24VDC, +5VDC	Production from April 2000 until March 2003. Senses Proximity only. Does not sense High Speed Drain Temperature. Supersedes probe 025-30961-000. 1-piece integrated design that includes the electronics in the barrel of the probe. Refer to FIG. 46
025-35900-001	+24VDC, +5VDC	Production from March 2003 until March 2006. Senses proximity only. Does not sense High Speed Drain Temperature. Supersedes probe 025-35900-000. 1-piece integrated design that includes the electronics in the barrel of the probe. Refer to FIG. 46.
025-40496-000	+24V	Production after March 2006. Supersedes all previous probes. Senses proximity only. Does not sense High Speed Drain Temperature. This probe assembly is a 2-piece design that has the electronics in a module that is separate from the probe. This design allows the electronics portion of the probe to be replaced separately, thus eliminating the need to evacuate the chiller refrigerant charge when replacing only the electronics portion of the probe. The probe is connected to the electronics module with a coaxial cable. Refer to FIG. 47 for parts breakout of probe assembly 025-40496-000.

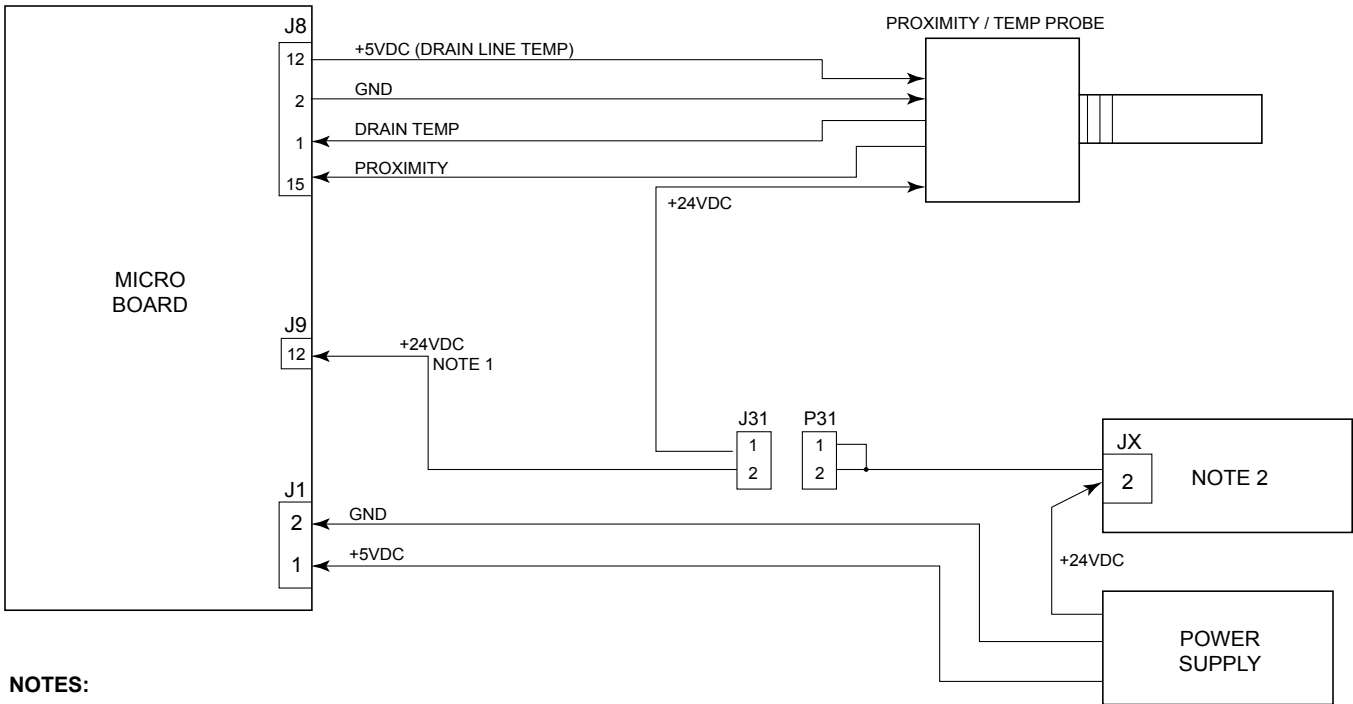

NOTES:

1. +24VDC Reference for "Proximity Probe - Low Supply Voltage" Cycling Shutdown.
2. CM-2 Board, Solid State Starter Logic Board or Adaptive Capacity Control Board as determined by the Starter Application.

LD04090

FIG. 45 – PROXIMITY PROBE INTERFACE-PROBE PART NUMBER 025-30961-000

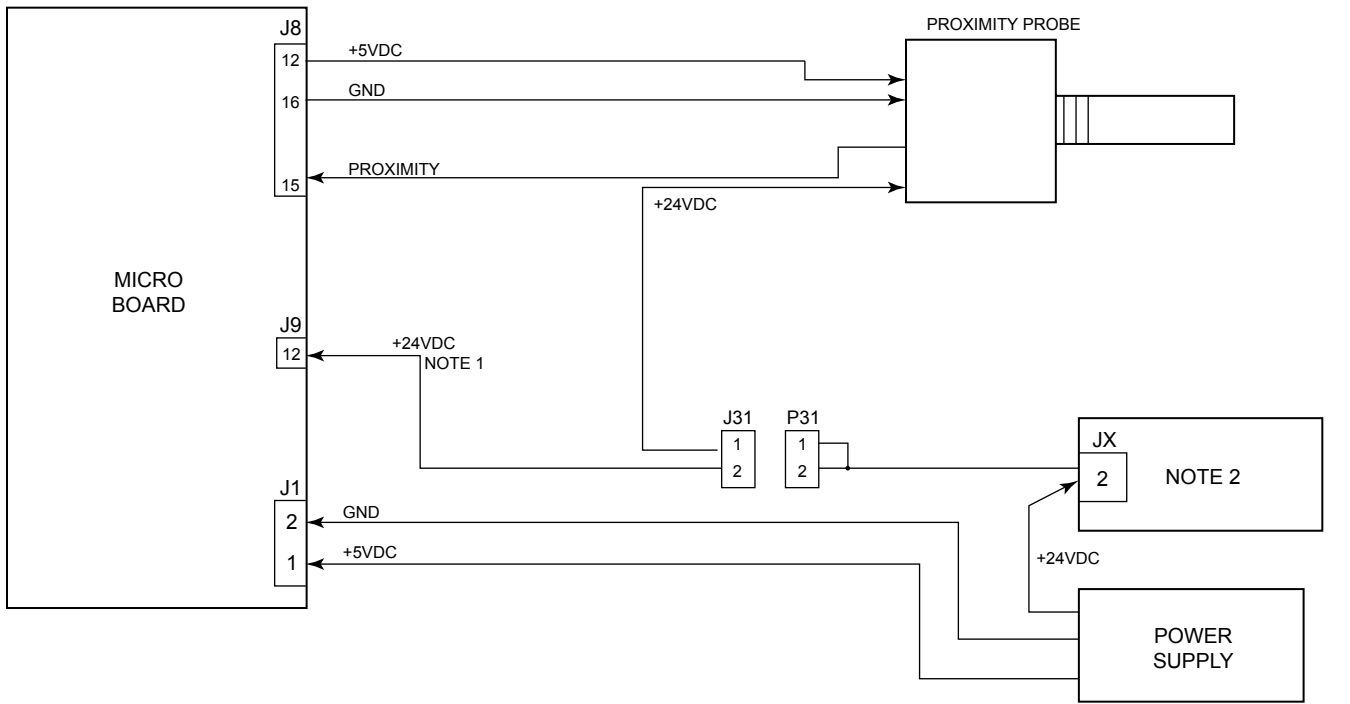

NOTES:

1. +24VDC Reference for "Proximity Probe - Low Supply Voltage" Cycling Shutdown.
2. CM-2 Board, Solid State Starter Logic Board or Adaptive Capacity Control Board as determined by the Starter Application.

LD05532C

FIG. 46 – PROXIMITY PROBE INTERFACE-PROBE PART NUMBER 025-35900-000 and 025-35900-001

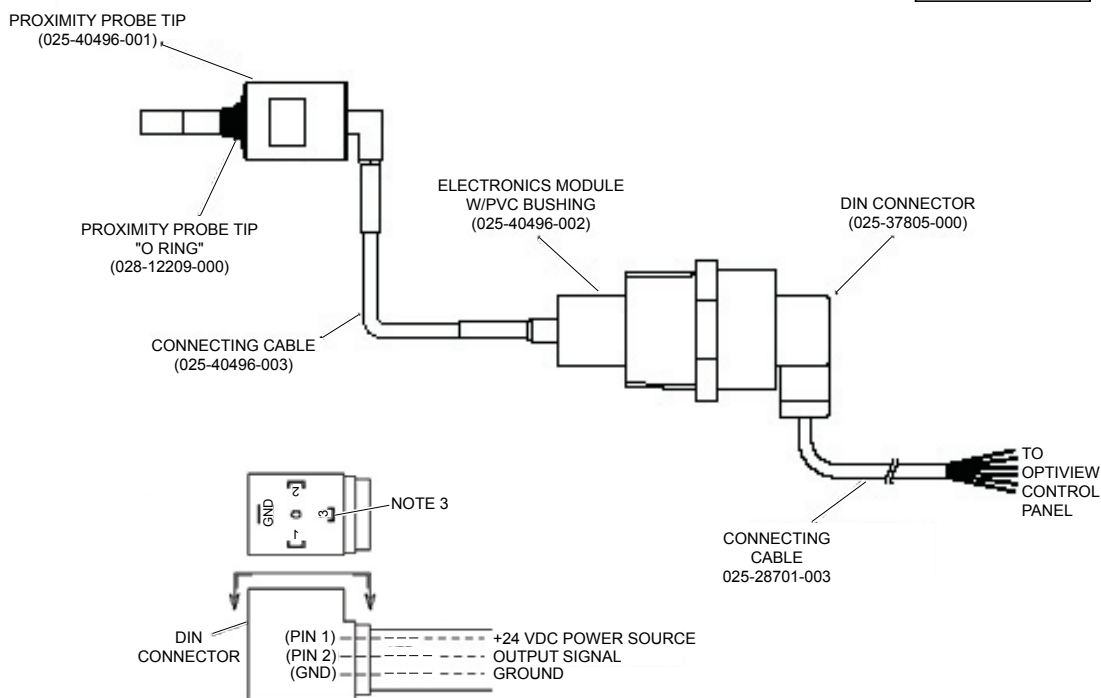
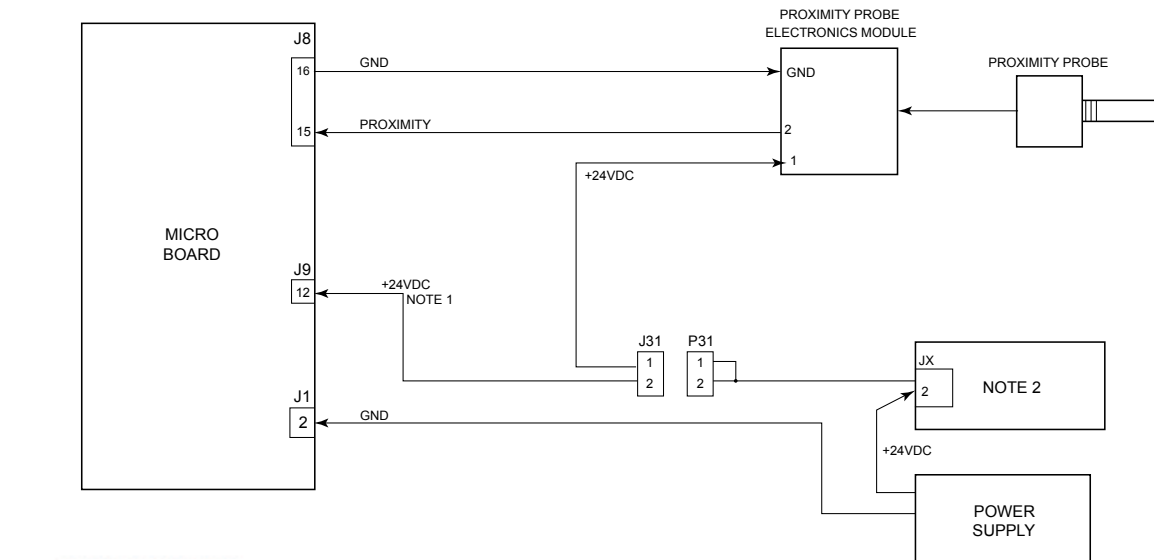

LD05532A

LD12570B

NOTES:

1. +24vdc Reference for “Proximity probe – Low Supply Voltage” Cycling Shutdown.
2. CM-2 Board, Solid State Starter Logic Board or Adaptive Capacity Control Board, as determined by starter application.
3. No wire is permitted to be connected to DIN connector Pin3. This pin is for Probe manufacturer’s use only. Connecting a wire to this pin will cause Probe malfunction.
4. Probe assembly 025-40496-000 consists of: Proximity Probe 025-40496-001, Electronics Module with PVC bushing 025-40496-002 and Probe to Electronics Module interconnecting cable 025-40496-003.
5. When replacing previous probe versions with this probe, use the existing cable and retrofit kit 364-51806-000, consisting of:
 - 025-40496-000 probe assembly (ref note 4)
 - 025-37805-000 DIN connector
 - 028-12209-000 O-ring
 - 035-21458-000 instruction drawing

FIG. 47 – PROXIMITY PROBE INTERFACE – PROBE PART NUMBER 025-40496-000

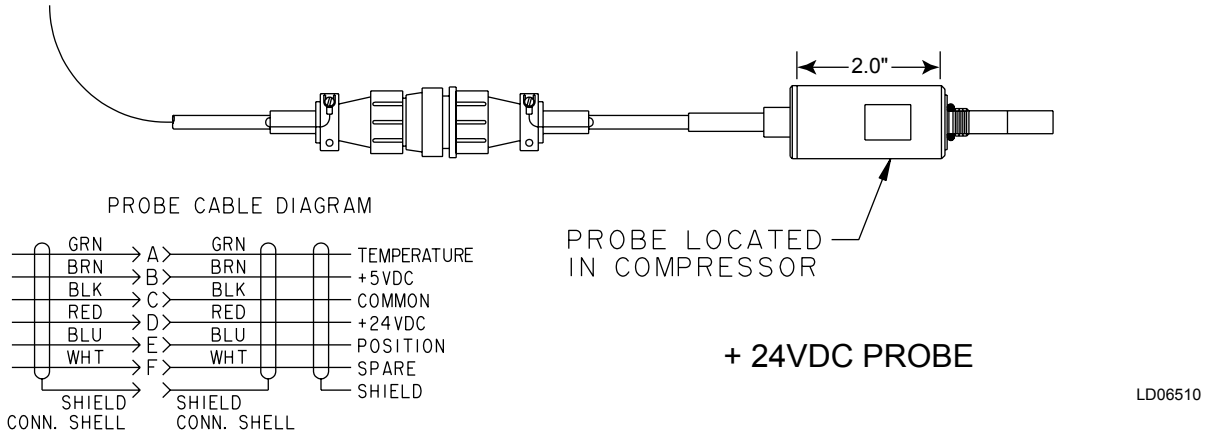

YORK PART NUMBER
025-30961-000

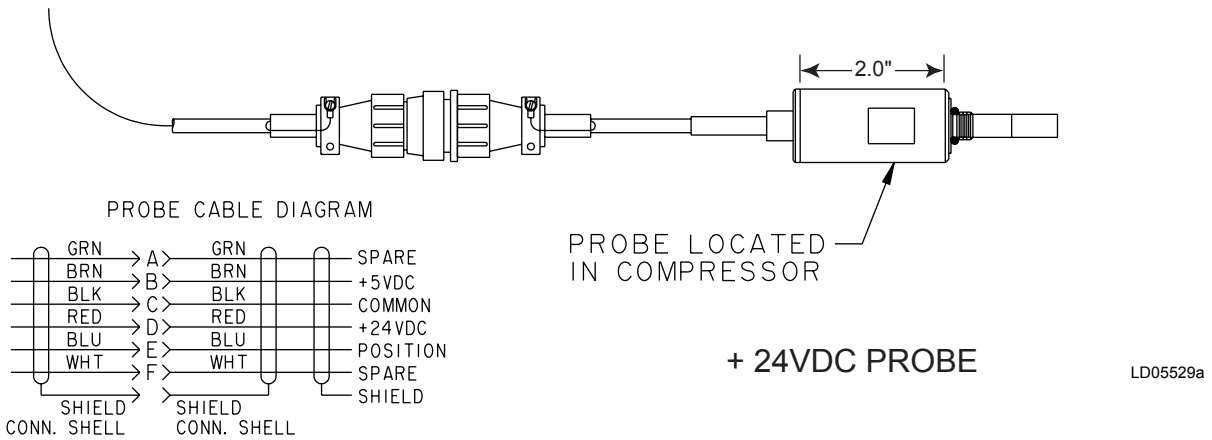

YORK PART NUMBER
025-35900-000 and 025-35900-001

FIG. 48 – PROXIMITY PROBE

SECTION 13A

HIGH SPEED THRUST BEARING LIMIT SWITCH

(REFER TO FIG. 49 - 50)

Chillers that are equipped with “P” compressors and style F and later chillers with “G” or “H5-8” compressors have a High Speed Thrust Bearing Limit Switch (025-34535-000) instead of the Proximity Probe described in Section 13. This device detects abnormal bearing position through probe contact instead of distance measurement as performed with the Proximity Probe.

The High Speed Thrust Bearing Limit Switch is an assembly consisting of a pressure switch attached to a probe that protrudes into the compressor housing. When the bearing position decreases to < the allowed position, it comes into contact with the probe, causing the break-away probe to detach, exposing the pressure switch to the pressure inside the compressor. A set of normally closed contacts inside the switch open when the switch is exposed to a pressure of > 15 to 25 PSIG. One side of these contacts is connected to 115VAC. The other side

connects to I/O Board TB3-81. The Microboard reads the state of these contacts through the I/O Board and when they open, a safety shutdown is performed and “THRUST BEARING – LIMIT SWITCH OPEN” is displayed on the System Details line of the Display. On the COMPRESSOR Screen, a red LED illuminates when the switch is closed; extinguishes when it is open.

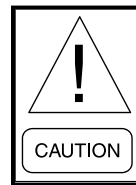

After the High Speed Thrust Bearing safety shutdown has occurred, the chiller cannot be restarted until a Thrust Bearing inspection, followed by a special reset procedure which has been performed by a qualified Service Technician. The reset procedure and Bearing inspection criteria is listed in the “System Calibration and Reset Procedures section of this book.

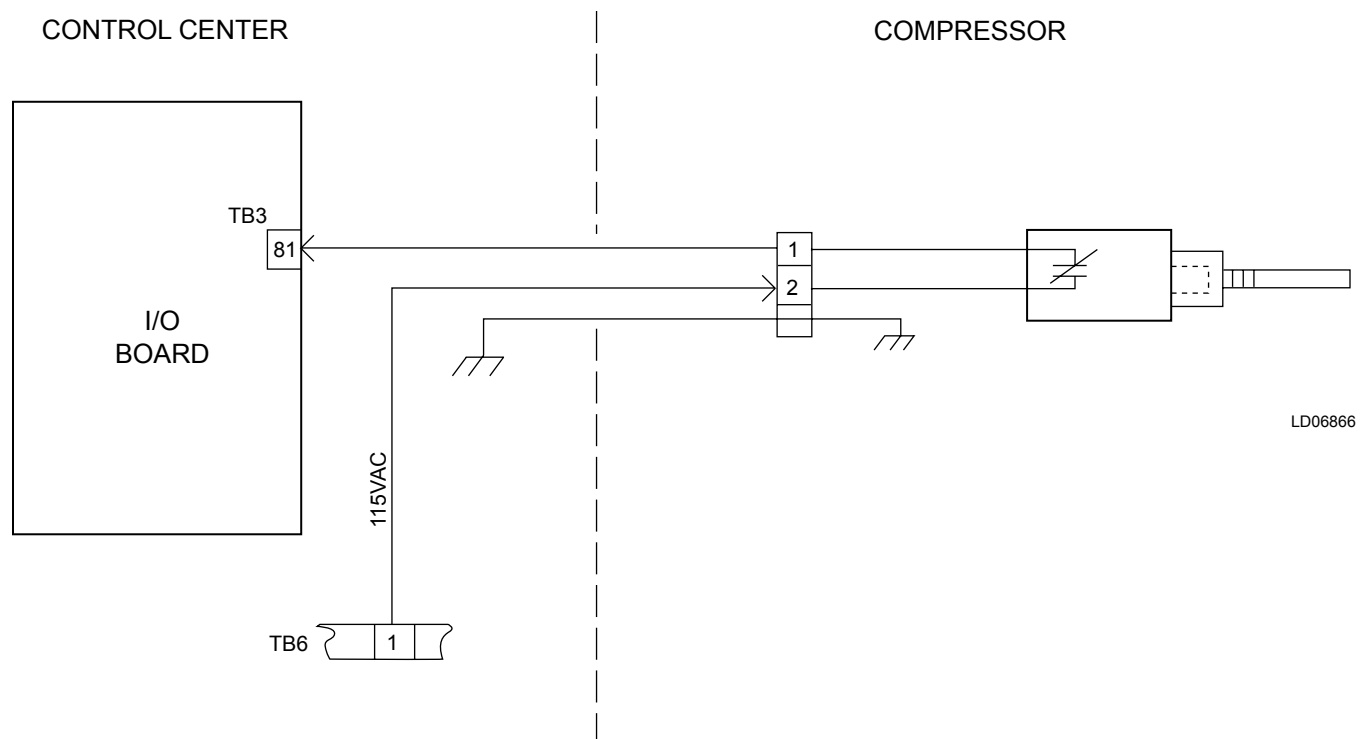
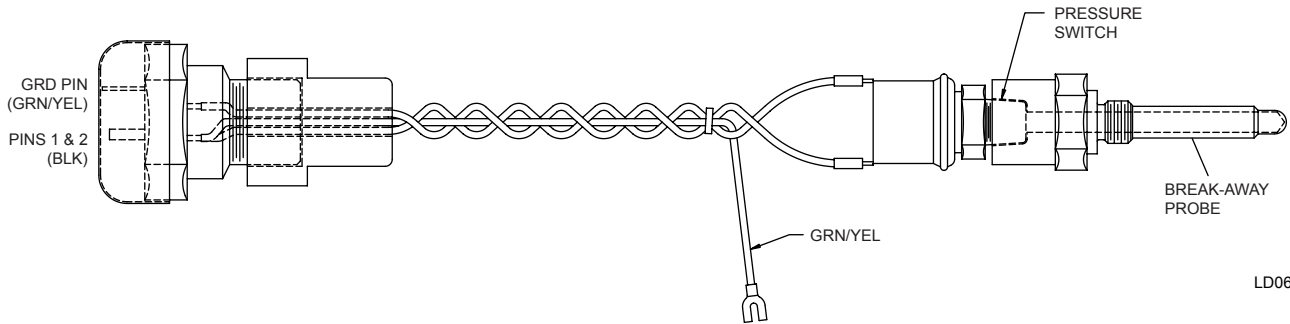

FIG. 49 – HIGH SPEED THRUST BEARING LIMIT SWITCH - INTERFACE



LD06860

FIG. 50- HIGH SPEED THRUST BEARING LIMIT SWITCH

SECTION 14 REFRIGERANT LEVEL CONTROL

(REFER TO FIG. 51 & 52)

The chiller can be provided with an optional Condenser **Refrigerant Level Control**. A **Variable Orifice**, located in the refrigerant liquid line between the Evaporator and Condenser, is used to control the refrigerant level in the Condenser. It is modulated by an **Actuator** that is driven by open and close output signals from Triacs on the I/O Board. These control signals originate at the Microboard. Automatic or Manual level control is allowed. If Automatic control is selected, the Program modulates the Variable Orifice to maintain the Condenser refrigerant to a programmable Setpoint level. If Manual control is selected, the Variable Orifice can be manually controlled with the Keypad keys. This Manual control can also be used to place the Orifice in a fixed position.

Since the Level Control feature is optional, the Program operation described here must be **ENABLED** on those chillers so equipped and **DISABLED** on all other chillers. This procedure, along with the programming of Setpoints described below, is performed on the Refrigerant Level Control/Tuning Screen using instructions in the “System Calibration, Service Setpoints and Reset Procedures Programming Procedures” section of this book.

A Liquid Level Sensor (LLS) detects the **Refrigerant Level** in the condenser and outputs an analog voltage to the Microboard that represents this level. The level is expressed as a percentage and is displayed on the Condenser Screen and the Refrigerant Level Control Screen as the “Refrigerant Level Position = xxx%”. The Level Sensor is calibrated so that the refrigerant level is displayed as 0% when the level is at minimum; 100% when the level is at maximum. Levels between these extremes are linearly scaled. The level is at minimum when the chiller is shutdown with the orifice in the fully open position. The level is at maximum when the level is above the site glass, with the sensor fully covered.

The Level Sensor calibration procedure is in the “System Calibration, Service Setpoints and Reset Procedures” section of this manual. There are different versions of the Level Sensors as shown in FIG. 50. The operation of the sensors is the same. However, the differences affect the way the sensors are calibrated. Some sensors are equipped with adjustable potentiometers, while others are equipped with pushbuttons that are used to calibrate the sensor.

The desired refrigerant level to be maintained in the condenser is the **Refrigerant Level Setpoint** and is displayed

as “Refrigerant Level Setpoint = xxx%” on the Condenser Screen and the Refrigerant level Control Screen.

This Setpoint is programmed by a Service Technician at chiller commissioning using the Refrigerant Level Control Screen. It is programmable over the range of 20% to 80%.

AUTOMATIC OPERATION

While the chiller is shut down, an Open signal is applied to the Actuator, driving the Orifice to the fully open position. This causes the Condenser refrigerant level to be approximately 0%. Elevated Evaporator pressure with respect to Condenser pressure could cause the level to be higher.

When a chiller start is initiated, there are two different courses of action taken, depending on the Flash Memory Card version as follows:

If equipped with Flash Memory Card version C.MLM.01.06.xxx and earlier or “P” compressors with C.MLM.04.02.xxx and earlier: After the chiller is started, when the Vane Motor Switch (VMS) opens after entering **SYSTEM RUN**, if the actual level is greater than the Level Setpoint, the Microboard begins controlling the level to the Level Setpoint. However, if the actual level is less than the Level Setpoint, a linearly increasing ramp is applied to the Level Setpoint. This ramp causes the Setpoint to increase from the initial refrigerant level to the programmed Level Setpoint over a period of 15 minutes. While this ramp is in effect, the ramp value is displayed as “REFRIGERANT LEVEL TARGET = XX%” and replaces the Level Setpoint message on the Condenser Screen. While the ramp is in effect, “RAMP UP TIME REMAINING = XX MIN” is displayed. After the 15 minute ramp period has elapsed, the refrigerant level is controlled to the programmed Level Setpoint.

If equipped with Flash Memory Card version C.MLM.01.07.xxx and later: Upon entering chiller Prelube, the Refrigerant Level close output is energized for the length of the programmable **Valve Preset Time** Setpoint (0 to 100 seconds; default 50). After pre-positioning, the valve is held in this position until the first 3 minutes of Chiller Run Time has elapsed (Setting the Valve Preset Time to 0 seconds disables this pre-positioning feature). During this 3 minute period, the Refrigerant Level Override displays "Valve Preset" and the Override Time Remaining displays the time remaining in the 3-minute countdown timer. After the chiller has been

running 3 minutes, if the level is greater than or equal to the Refrigerant Level Setpoint, it begins controlling to the Setpoint (with software version C.OPT.01.21.307 and later, after entering System Run, if the refrigerant level is greater than the programmed Level Setpoint for 2 seconds, the preset/hold timer is canceled and normal level control is started immediately, regardless of whether or not the Preset position has been reached or the 3 minute timer has elapsed).

However, if it is less than the Refrigerant Level Setpoint, a linearly increasing ramp limit, called the **Refrigerant Level Target**, is applied to the Refrigerant Level Setpoint. This ramp limit allows the level to go from the present level to the Refrigerant Level Setpoint over a period of time programmed as the **Ramp-Up Time** setpoint (3 to 15 minutes; default 8). During this ramp-up period, the Refrigerant Level Target is used to control the refrigerant level in the condenser and the Refrigerant Level Setpoint message on the Condenser Screen is replaced by “REFRIGERANT LEVEL TARGET = XX%”. While the ramp is in effect, “RAMP UP TIME REMAINING = XX MIN” is displayed. After the ramp period has elapsed, the refrigerant level is controlled by the Refrigerant Level Setpoint for the remainder of chiller run. If the Valve Preset Time is set to 0 seconds and the Ramp-Up Time Setpoint is set to 15 minutes, the control will operate the same as previous Software versions, as described above.

The Program applies an open or close signal, as required, from the Microboard to the actuator to maintain the level to the Level Setpoint. The duration of the signal determines the magnitude of change to the Orifice position. The duration of the signal and whether it is an open or close signal depends upon the Proportion Error and the Rate of Change of the actual level compared to the Level Setpoint in a recurring period of time called a **Level Control Period**. At the end of each Level Control Period, the Proportion error and Rate of Change are compared to control thresholds **Proportion Limit Close**, **Proportion Limit Open** and **Rate Limit Close** and **Rate Limit Open**. The result of this comparison determines the signal that will be applied to the actuator at the end of the Level Control Period as explained below. The setpoint values used by the program is determined by the Software vintage. In earlier versions, the values are programmable setpoints as shown below. In later versions, they are fixed and programmable values applied in two different Zones, as determined by the error relationship of the actual refrigerant level and the Level Setpoint as shown below.

Software version C.MLM.01.11.xxx (and earlier) or C.OPT.01.11.xxx (and earlier)

- Level Control Period-3.5 to 30.0 seconds (default 3.5)
- Proportion Limit Open-10% to 50% (default 15)
- Proportion Limit Close-10% to 50% (default 45)
- Rate Limit Open-5% to 50% (default 10)
- Rate Limit Close-5% to 50% (default 10)
- Proportion Error Deadband - $\pm 3\%$
- Rate Error Deadband - $\pm 1\%$

Software version C.MLM.01.14.xxx (and later) or C.OPT.01.14.306(and later)

In this version, some control thresholds are fixed while others are programmable. This provides more stable control in certain operating conditions. The control thresholds are applied in two different zones, as determined by the error relationship between the actual refrigerant level and the Level Setpoint as shown below. Zone 1 parameters are used when the error is $< 9\%$. Zone 2 parameters are used when the error is $> 9\%$. When transitioning from Zone 2 to Zone 1, the error must be $< 9\%$ for 60 seconds before the Zone 1 parameters are used. If the error is $> 9\%$, the Zone 2 parameters are immediately implemented.

On the Refrigerant Level Control Screen, the Zone Control State status box displays which zone of control is being used: “Zone 1”, “Zone 2”, “Zone Control Off” (if chiller shutdown). When transitioning from Zone 2 to Zone 1, “Zone 2 to Zone 1” is displayed and the “Zone Control Time Remaining” status box displays the amount of time remaining in the 60-second countdown timer.

The following are the control thresholds:

	<u>Zone 1</u>	<u>Zone 2</u>
Proportion Limit Open (fixed)	50%	52%
Proportion Limit Close (fixed)	45%	45%
Rate Limit* (setpoint)	3%-15%	3%-15%
default	7%	5%
Period (setpoint) (seconds)	8-22	2.5-10
default	15	2.5

	<u>Zone 1 & Zone 2</u>
Level Setpoint	20% to 80%; default 30%
Valve Preset Time (setpoint) (seconds)	0 to 100; default 50
Ramp Up Time (setpoint) (minutes)	3 to 15; default 8
Proportion Error Deadband - +0%	
Rate Error Deadband - +0%	

*This RATE LIMIT setpoint sets the Rate Limit threshold for refrigerant levels both above (open) and below (close) the Refrigerant Level Setpoint.

The entire chiller run time is divided into Level Control Periods. They occur consecutively and continuously. The first one begins upon entering **SYSTEM RUN** and when it ends the next one begins, etc. This repeats until the chiller is shutdown. The duration of these periods are programmed as the **Level Control Period Setpoint**. At the completion of each Level Control Period, the actual level is compared to the Level Setpoint. The result is the Proportion Error. The Proportion Error is compared to Setpoints Proportion Limit Open (if level is above setpoint) and Proportion Limit Close (if level is below setpoint). If the Proportion Error exceeds the Limit, the Proportion Error influence in the response will be large. If the Proportion Error is less than the Limit, the Proportion error influence in the response is determined by how close the Proportion Error is to the Limit; close yields larger influence, further yields smaller influence. To establish the response to the rate of change, the amount of change in the Level within the Level Control Period is compared to the Rate Limit Close (if level less than setpoint) and Rate Limit Open (if level greater than setpoint). If the result exceeds the Setpoint, the rate influence in the response will be large; if less than the Setpoint, the rate influence is determined by how close the result is to the Setpoint; close yields larger influence, further yields smaller influence.

Therefore, per the above, the values programmed for Proportion Limit Open/Close and Rate Limit Open/Close determine the sensitivity of the level control. Smaller values generally yield greater response for the same level change in the Level control Period. Also, the smaller the value programmed for the Level Control Period, the more often an output signal is applied to the Variable Orifice Actuator. The orifice valve movement is animated on the Refrigerant Level Control Screen as follows: when 0-20% open, shown fully closed; 20 - 40% open, shown as 20% open; 40 - 60% open, shown as 40% open; 60 - 80% open, shown as 80% open; 80 - 100% open, shown as 100% open.

14

MANUAL OPERATION

The Orifice Actuator can be manually controlled from the Keypad using the Refrigerant Level Control Screen after logging in at **SERVICE** access level. Open, Close, Hold and Auto keys are used to control the Variable Orifice. Using the Open, Close and Hold keys, the Variable Orifice can be placed in a fixed position. Pressing the Auto key returns Level Control to Automatic operation.

ACTUATORS

New production units use a Belimo actuator that operates from 24VAC. If the OptiView Control Center is retrofit to an existing chiller, the chiller could be equipped with a Barber-Coleman actuator that operates from 115VAC. The interface for both actuators is shown in FIG. 52. The description of the operation of both actuators is in the "I/O Board" section of this book.

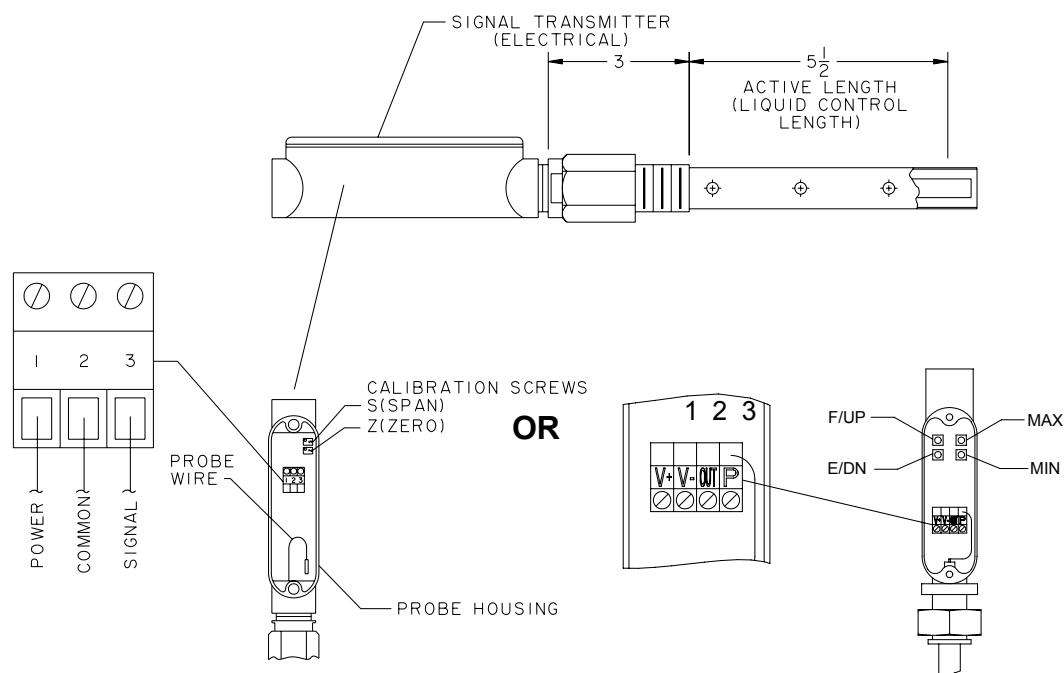
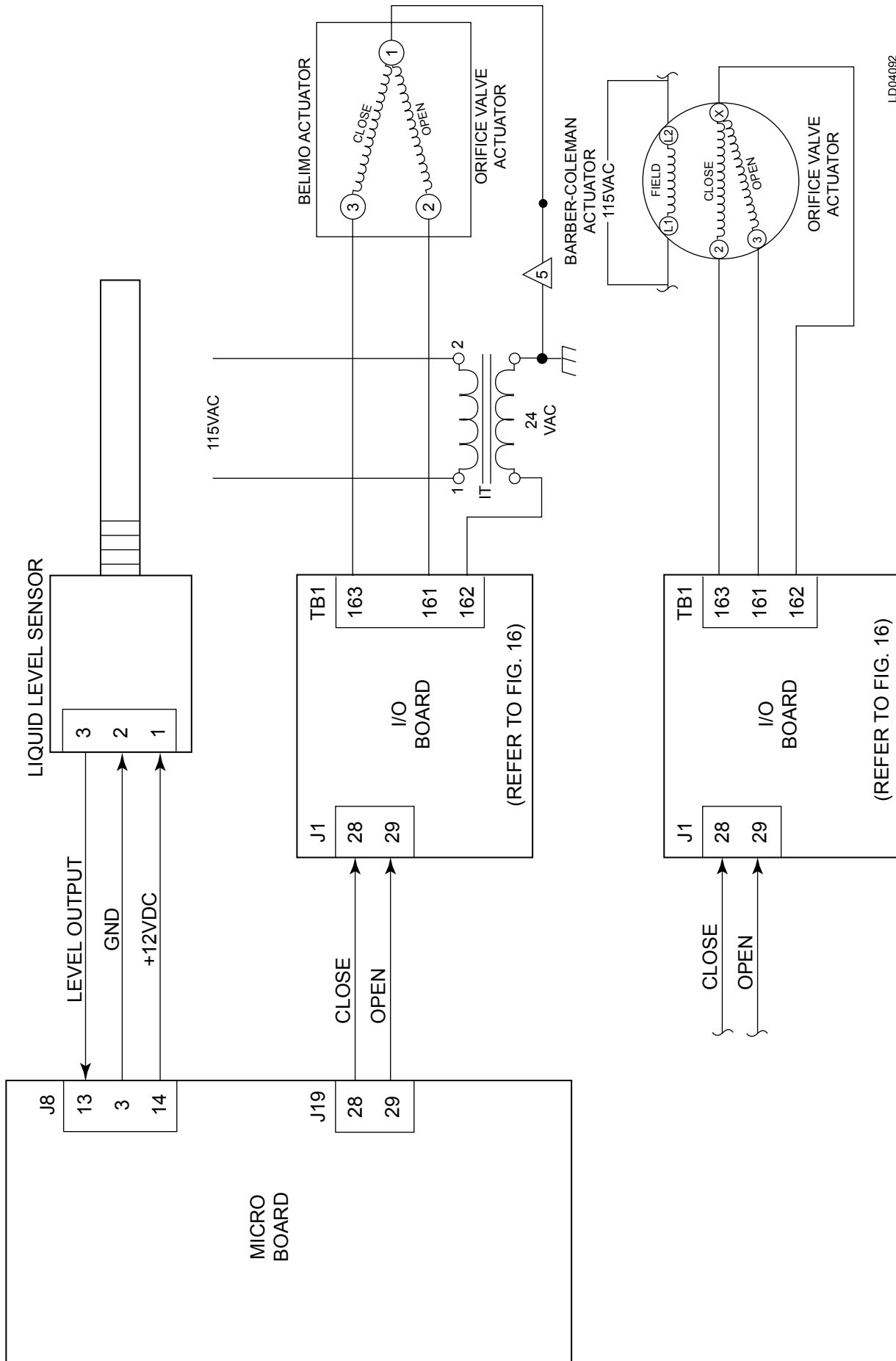

FIG. 51 – REFRIGERANT LIQUID LEVEL SENSOR



LD04092

FIG. 52 – REFRIGERANT LIQUID LEVEL CONTROL - INTERFACE

SECTION 15

OIL PUMP VARIABLE SPEED DRIVE

(REFER TO FIG. 53 - 55)

On style D and later chillers, the oil pump is driven by a **Variable Speed Drive (VSD)** (Refer to Service Manual 160.52-M2 for details of this device). In normal operation, the oil pump speed is automatically controlled to maintain a desired oil pressure. The speed can be manually controlled with the Keypad keys using the Oil Sump Screen with Service access level.

On those chillers equipped with the oil pump VSD, the VSD operation as described below must be **ENABLED** by placing Microboard Program Switch SW1-2 in the ON position. Those chillers not equipped with the oil pump VSD must have this operation **DISABLED** by placing SW1-2 in the OFF position. Refer to Table 2, “Microboard Program Switches”.

The programming of the Setpoints referred to below is performed on the Oil Sump Screen using instructions in the “System Calibration, Service Setpoints and Reset Procedures” section of this book. These Setpoints should not be programmed by anyone other than a qualified Service Technician. Variable speed oil pump chillers are not equipped with the Liquid Line Solenoid Valve (2SOL), or High Speed Thrust Solenoid Valve (4SOL). Therefore, when Oil Pump VSD operation is **ENABLED** with Program Switch SW1-2, the Program is configured to operate the chiller without these solenoid valves. Operation Sequence Timing Diagrams in FIG. 4 and 5 depict chiller operation with the Oil Pump VSD enabled or disabled. Also, when equipped with the oil pump VSD, the Microboard, under Program control, controls the Oil Heater to maintain a specific oil temperature as described in the “Oil Heater” section below.

AUTOMATIC OPERATION

Under Program control, a speed command signal from the Microboard controls the oil pump speed by varying the VSD output frequency. The speed command is in the form of a Pulse Width Modulation (PWM) Signal as explained below. During the **System Prelube** period and the first 15 seconds of **System Run**, the Program operates the oil pump VSD over the range of 25 Hz to 60 Hz to maintain the oil pressure to the target value of 45 PSID. For the remainder of **System Run** and the **Coastdown** period, it operates it over the same frequency range to maintain the pressure to the programmed **Oil Pressure Setpoint**.

When the chiller is started, 13 seconds after the **System Prelube** is initiated, the Microboard (J20-3) starts the oil pump by driving the EN (enable) input of the Oil Pump VSD to a Logic Low level (<1VDC). The Microboard (J20-1) then applies a speed command signal to the PWM input of the VSD that ramps the VSD output frequency from 25 Hz (45 Hz on all “P” compressors. 45 Hz on other compressor applications equipped with Flash Memory Card version C.MLM.01.05.xxx and later) to whatever frequency is required (up to a maximum of 60 Hz) to achieve the **Target Oil Pressure**. (If equipped with Flash Memory card version C.MLM.01.08.xxx (and later), it is held at 45Hz for 8 seconds before releasing to normal control). The Target Oil Pressure is fixed at 45 PSID. The speed command is displayed on the Oil Sump Screen as **OIL PUMP DRIVE COMMAND FREQUENCY = XX HZ**. The speed command to the VSD is modulated as required to maintain the 45 PSID Target Oil Pressure for the remainder of **System Prelube** and the first 15 seconds of **System Run**. While this target is in effect, it is displayed on the Oil Sump Screen as **TARGET OIL PRESSURE = 45 PSID**. The time remaining that the Target Oil Pressure is in effect is displayed as a countdown timer in the message **PULLDOWN TIME REMAINING = XX SEC**. After the compressor has been running for 15 seconds, the speed of the VSD is controlled to maintain the programmed **Oil Pressure Setpoint** (20 to 45 PSID). This is displayed on the Oil Sump Screen as **SETPOINT OIL PRESSURE = XX PSID**.

During Oil Pump operation, the following minimum and maximum oil pressures are allowed:

1. During **Automatic** operation, if either of the following conditions occur, a Safety shutdown is performed and **OIL - VARIABLE SPEED PUMP - PRESSURE SETPOINT NOT ACHIEVED** is displayed. These conditions are not checked in **MANUAL** operation. With software version C.OPT.01.18.307 (or later), when the refrigerant selection (microboard 031-02430-000/001 SW1-1) is set to R22, these conditions are not checked.
 - a. If the Oil Pressure is <35 PSID (< 25.0 PSID for “P” compressors equipped with software version C.MLM.01.10A.xxx (and earlier) or C.OPT.01.10A.xxx (and earlier) for 5 continuous seconds during the last 10 seconds of **System Prelube** or during the first 15 seconds of **System Run**.

- b. If the Oil Pressure is < the programmed Oil Pressure Setpoint and the speed command is at 60 Hz for 5 continuous seconds, any time after the first 30 seconds of SYSTEM RUN.
2. During **Automatic** operation, if the Oil Pressure decreases to ≤ 15 PSID, a Safety shutdown is performed and **OIL - LOW DIFFERENTIAL PRESSURE** is displayed. If it increases to ≥ 90 PSID (120.0 PSID with software versions C.MLM.01.08.xxx (and later) or C.OPT.01.08A.xxx (and later)), a Safety shutdown is performed and **OIL - HIGH DIFFERENTIAL PRESSURE** is displayed.

The Microboard controls the VSD output frequency by applying a **Pulse Width Modulation (PWM)** speed command signal to the VSD. The signal is applied every 0.7 seconds. Within the 0.7 second period, the duration of time the signal is at logic low (<1VDC) and logic high (+12VDC) level determines the VSD output frequency between 25 and 60 Hz. If it remains at a logic high for the entire 0.7 second period, it is commanding the VSD output frequency to be 25 Hz. If it is low for the entire 0.7 second period, it is commanding the VSD output frequency to be 60 Hz. Frequencies between these extremes are achieved by driving the signal low for a proportionate amount of time within the 0.7 second period. For example, if the signal is low for 50% (0.35 seconds) of the 0.7 second period, it would be commanding the VSD to operate at a frequency that is halfway between 25 and 60 Hz, or 42.5 Hz. The resolution, or smallest increment of change is 0.01 seconds. This allows the output frequency to be changed in 0.5 Hz steps. The VSD output frequency for any PWM input can be calculated as follows:

$$\text{Frequency in Hz} = (\text{On-Time in seconds} / 0.02) + 25$$

The entire oil pump run time is divided into Oil Pressure **Control Periods**. They run consecutively and continuously; when the first one ends, the next one begins, etc. This repeats until the oil pump is shutdown. The duration of the periods is determined by the **Control Period Setpoint**. This Setpoint is programmed in multiples of 0.3 seconds over the range of 0.3 to 2.7 seconds. At the end of each period, the actual oil pressure is compared to the Oil Pressure Setpoint and the speed command is changed as required to invoke VSD frequency changes to increase or decrease the oil pressure. If the error between the Oil Pressure Setpoint and the actual oil pressure is $\leq \pm 6$ PSID, the frequency is increased or decreased 0.5 Hz

to increase or decrease the oil pressure. However, if the error is $> \pm 6$ PSID, the value programmed for **Control Period Setpoint** determines the relative magnitude of correction applied to the VSD output frequency. The larger the programmed value, the greater the amount of correction above 0.5 Hz is applied.

To provide an operational status to the Microboard (via I/O Board TB3-70), the VSD contains a set of normally open (N.O.) relay contacts that are driven closed as long as all the internal protection circuits are satisfied. They open anytime these circuits will not permit the VSD to operate. The opening of these contacts initiate a chiller **cycling** shutdown, displaying **OIL - VARIABLE SPEED PUMP - DRIVE CONTACTS OPEN**. After the problem has cleared, the contacts automatically close, except if the VSD experiences a short circuit on the output; this requires the VSD to be manually reset by the removal and restoration of the VSD AC Power.

MANUAL OPERATION

The oil pump can be manually operated using the Oil Sump Screen when logged in with **SERVICE ACCESS** level. While the chiller is running, the speed can be manually adjusted over the range of 25 to 60 Hz. When the chiller is not running, manual on/off control, as well as manual speed control is permitted. After the pump is manually turned on, it will automatically turn off after 10 minutes of operation, if not manually terminated earlier.

The **RAISE** and **LOWER** keys are used to increase and decrease the VSD output frequency in 0.5 Hz increments. Each time the **RAISE** key is pressed, the frequency is increased 0.5 Hz. Each time the **LOWER** key is pressed, the frequency is decreased 0.5 Hz. Repeated presses of these keys are required to increase or decrease the frequency by greater amounts.

If the **AUTO** key is pressed, Automatic operation, as described above, is resumed.

If the **SET** key is pressed, the VSD is driven to a specific predetermined frequency. This permits service analysis of the oil pressure at various oil pump speeds. This frequency is programmed using instructions in the "System Calibration, Service Setpoints and Reset Procedures" section of this book.

During Manual operation, the Oil Sump Screen can be used to monitor the actual oil pressure and the speed command.

OIL HEATER OPERATION

On chillers equipped with the oil pump VSD, the oil heater is controlled by the Microboard via I/O Board. The connection to the I/O Board is determined by the chiller style and compressor type as follows:

- TB1-34 - Style D and E chillers with “G”, “H” or “J” compressors
- TB1-64 - Style E chillers with “P” compressors and all Style F and later chillers.

When the oil pump is not operating, the heater is turned on and off to maintain a target value of 50°F above the Condenser Saturation Temperature. If the calculated target value is > 160°F, the target value defaults to 160°F. If the calculated target value is < 110°F, it defaults to 110°F. When the temperature decreases to 4°F below the target value, the heater is turned on; it is turned off at 3°F above the target.

To prevent overheating the oil in the event of an OptiView Control Center failure, thermostat 1HTR opens at 180°F.

15

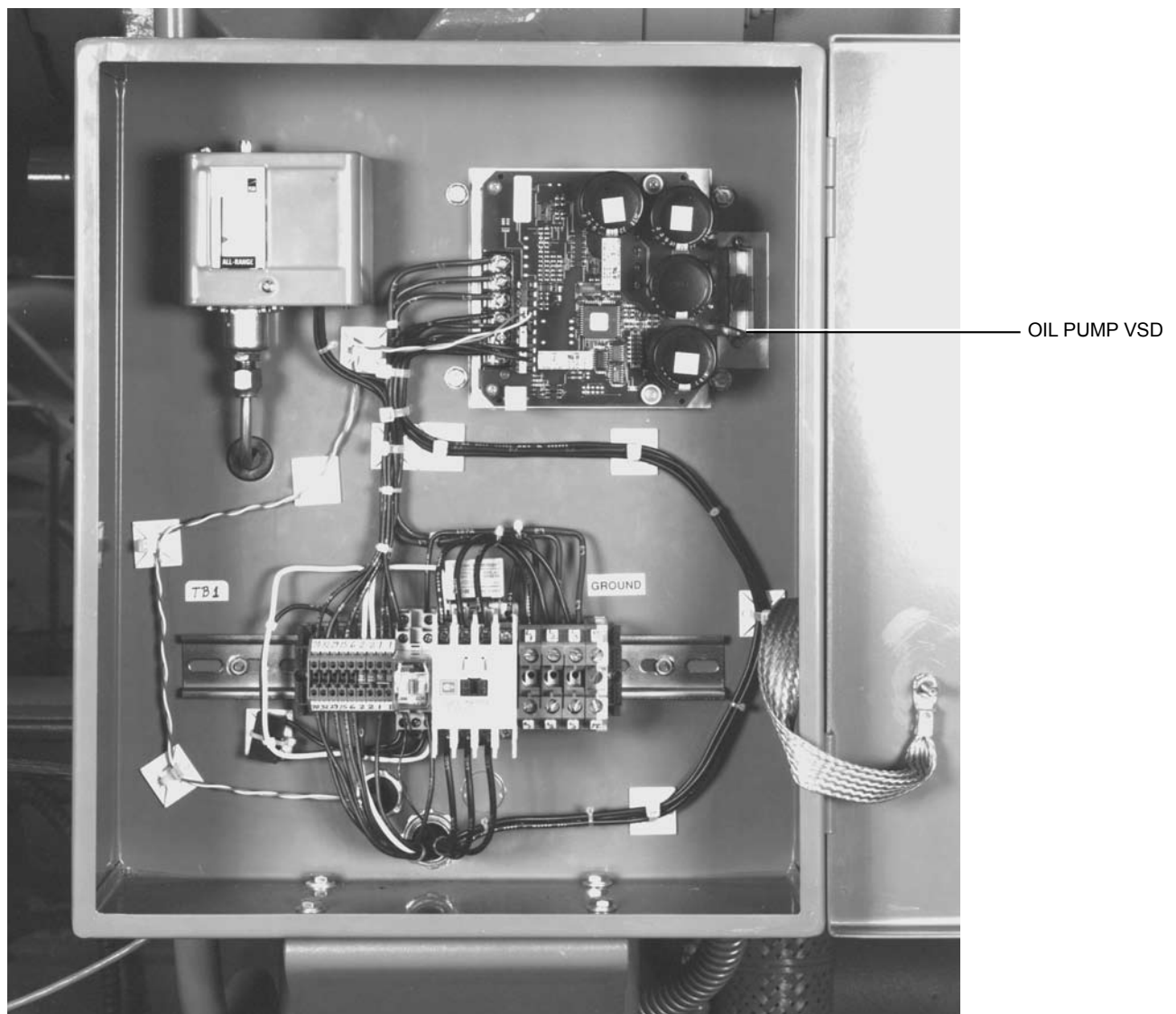

28782A

FIG. 53 – OIL PUMP VARIABLE SPEED DRIVE (VSD)

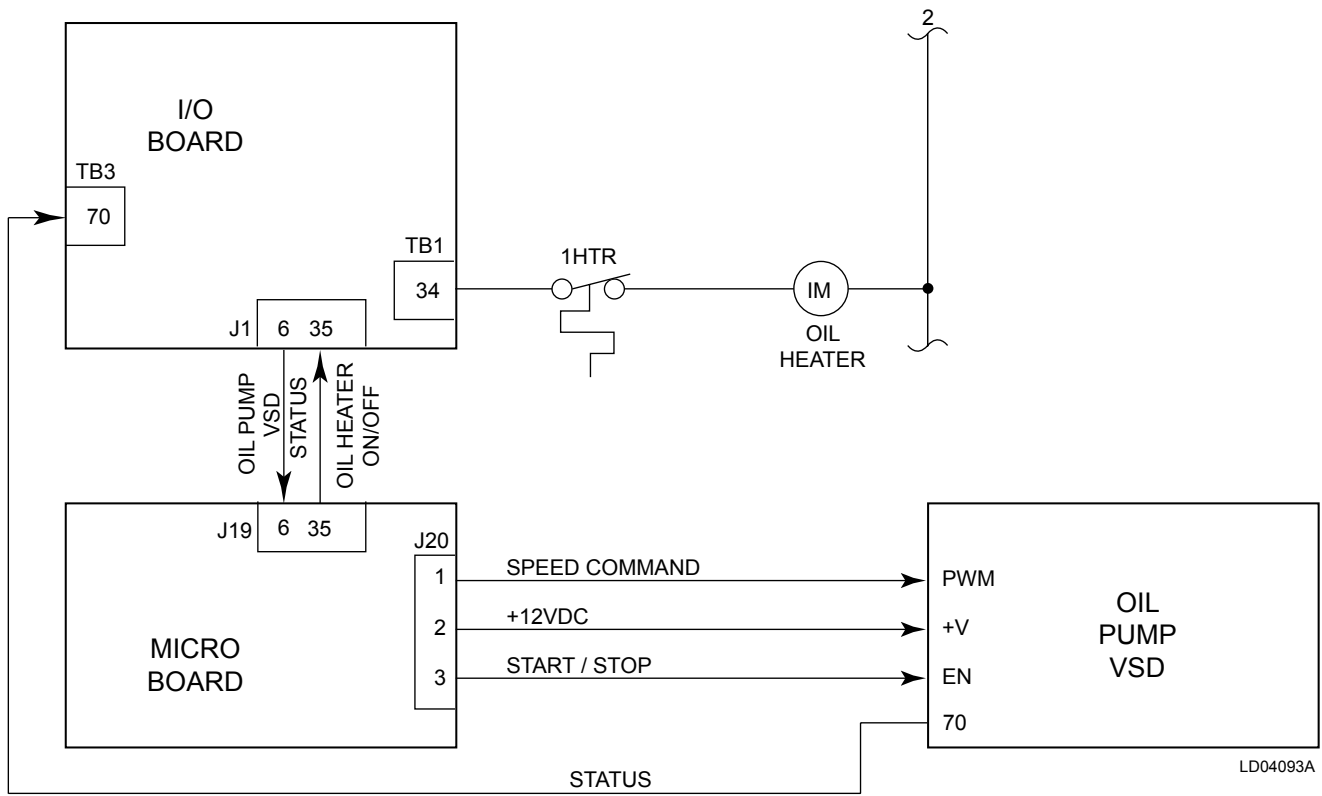
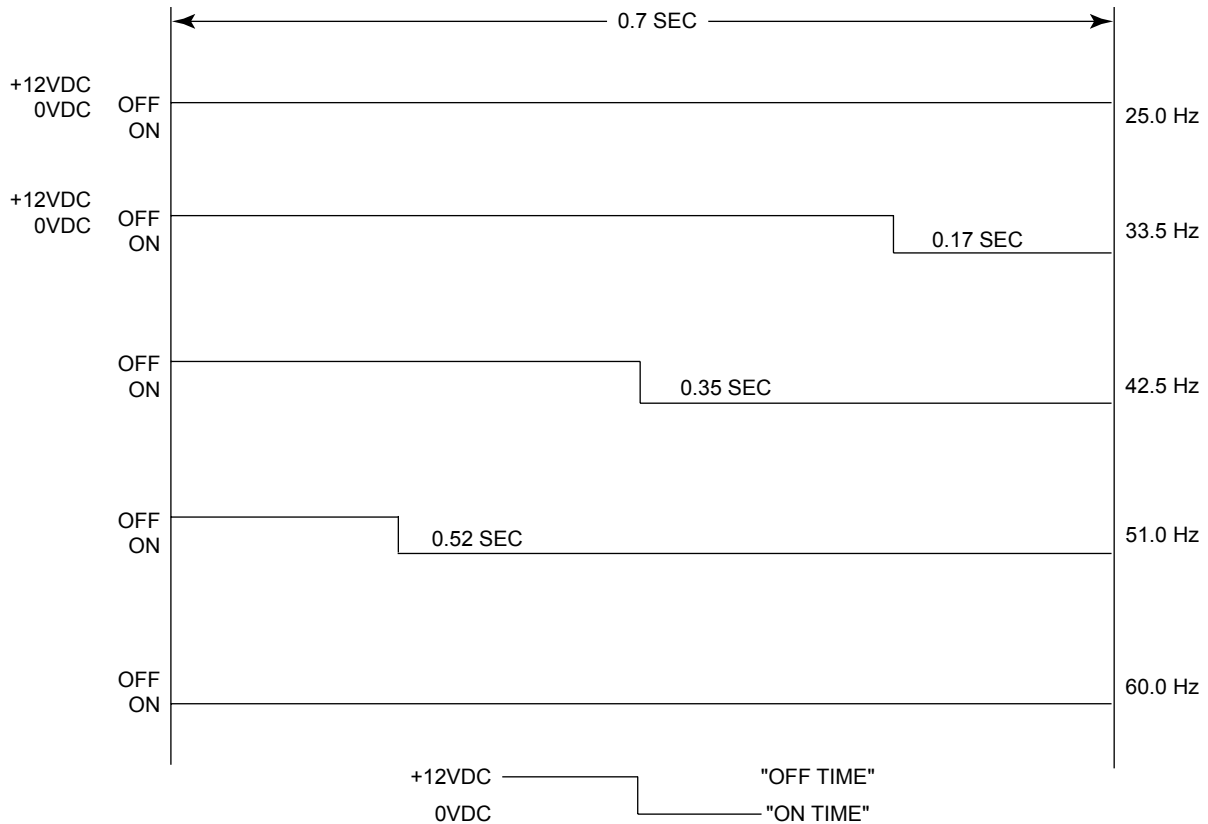

FIG. 54 – OIL PUMP VSD / OIL HEATER CONTROL – INTERFACE



LD04094

FIG. 55 – OIL PUMP VSD SPEED CONTROL SIGNAL

SECTION 16 MICROGATEWAY (REFER TO FIG. 56)

The complete description of the MicroGateway installation and operation is contained in YORK form 450.20-NOM1.

The MicroGateway is an optional printed circuit board that provides an interface between the OptiView Control Center and YORK ISN (Integrated Systems Network) or other selected networks. It can be mounted on the upper corner of the left wall of the OptiView Control Center or in its own enclosure in a remote location.

If installed in the OptiView Control Center, the MicroGateway is powered by +12VDC from the Microboard.

The MicroGateway communicates with the Microboard COM 4B communications port via an RS-232 interface. As shown in FIG. 11, Microboard Program Jumper JP 27 must be placed on pins 2 and 3 to allow data to be received from the MicroGateway.

If the remote device that is connected to the MicroGateway is going to provide remote Start/Stop signals, remote Leaving Chilled Liquid Temperature and/or remote

Current Limit Setpoint resets, the Control Source must be set to ISN on the OPERATIONS Screen. Otherwise, communications will take place in any Control Source mode.

In operation, the Microboard provides chiller pressures, temperatures and status to the MicroGateway in response to requests from the MicroGateway. Microboard status LEDs illuminate when the Microboard transmits and receives data on COM 4B. Green LED CR13 (RX4) illuminates when data is being received from the MicroGateway. Red LED CR12 (TX4) illuminates when data is being transmitted to the MicroGateway. Similar LEDs on the MicroGateway annunciate data transfer to/from the Microboard (refer to 450.20-NOM1).

If there is a communications problem between the Microboard and MicroGateway, use the LEDs described above to analyze the problem. The COM 4B LoopBack test can be used to verify operation of the Microboard COM 4B communications port. Refer to Diagnostics and Troubleshooting section of this book.

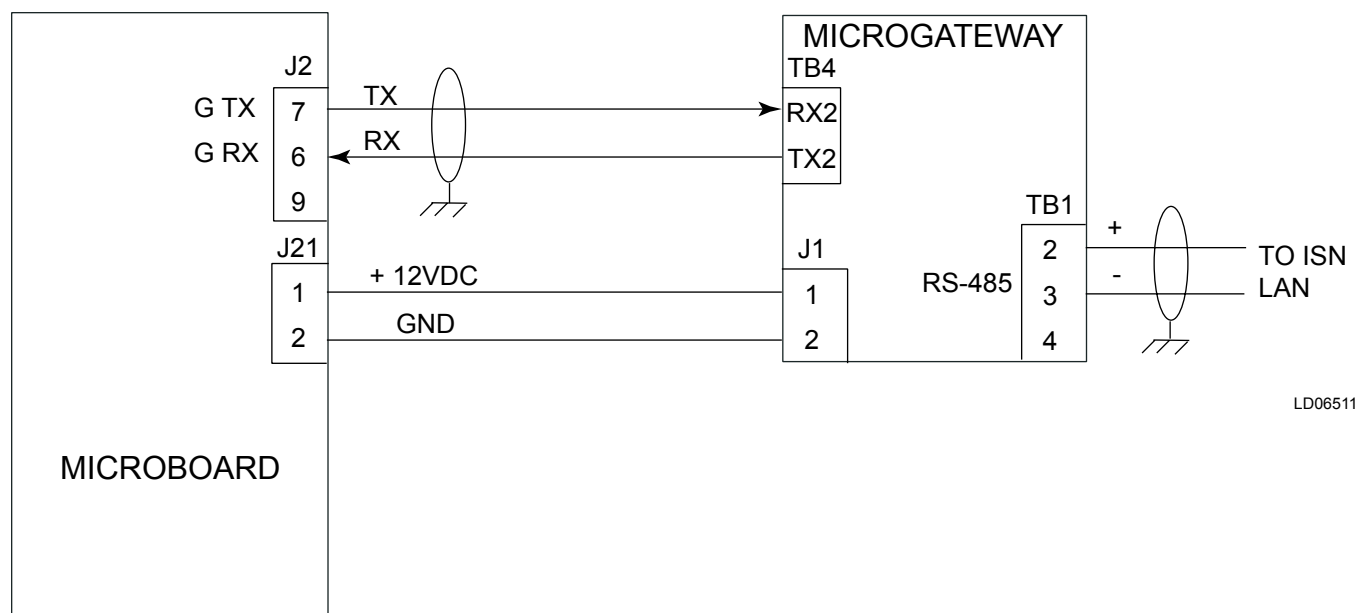

LD06511

FIG. 56 – MICROGATEWAY INTERFACE BLOCK DIAGRAM

SECTION 17

PRESSURE TRANSDUCERS

(REFER TO FIG. 57)

System pressures are sensed by **Pressure Transducers**. The Evaporator, Condenser, Pump Oil (high side) and Sump Oil (low side) pressures are sensed. If the chiller is equipped with the Variable Geometry Diffuser, a Stall Detection transducer is located in the discharge scroll of the compressor (refer to Variable Geometry Diffuser Section 22A for details). There are different transducers used to sense these various pressures. The actual transducer used is determined by the required pressure range and refrigerant application. The operation of the various transducers is identical. The difference between them is simply the pressure range over which they operate. Each of the different transducers has a different YORK part number. FIG. 55 lists the transducers and the application of each one.

The transducers output a 0.5 to 4.5VDC voltage that is analogous to the pressure applied to the device. These outputs are applied to the Microboard, where this voltage is interpreted as a pressure value in terms of PSIG (pounds per square inch gauge) in English mode or KpaG (Kilo Pascals) in Metric mode. The Program converts the transducer output voltage to a pressure value with the appropriate formula in FIG. 57. The pressures are displayed and used for Chiller control and Safety shutdowns.

The Evaporator and Condenser pressures are converted to Saturation Temperatures per the appropriate refrigerant pressure/temperature conversion table contained in the Program. These Saturation Temperatures are displayed and used for Chiller control.

The outputs of the Sump and Pump oil Pressure transducers are displayed individually as PSIG values. However, the System Oil Pressure is displayed as a differential value in terms of PSID (pounds per square inch differential in gauge). This PSID value is arrived at by subtracting the Sump Oil Pressure transducer value from the Pump Oil Pressure transducer value. During the **System Prelube** period, the outputs of the oil Pressure transducers are compared in a process called **Auto-Zeroing**. The differential between the Sump and Pump Oil Pressure transducer outputs during a 3 second period beginning

10 seconds after the start of the **System Prelube** period are compared to determine the offset between them. During this period, since both of the transducers are sensing the same pressure, their outputs should indicate the same pressure. However, due to accuracy tolerances in transducer design, differences can exist. Therefore, to compensate for differences between transducers and assure differential pressure accuracy, this offset is factored with the actual differential pressure to produce the displayed PSID value. When the oil Pump is turned on following the Auto-zeroing period, the displayed differential value then becomes the actual differential plus or minus the offset that existed during the Auto-Zeroing period. For example, if the Pump transducer indicates 1.0 PSIG greater than the Sump transducer during the Auto-Zeroing period, then 1.0 PSIG will be subtracted from the displayed PSID value while the pump is running. Similarly, if the Pump transducer indicates 1.0 PSIG less than the sump transducer during this period, then 1.0 PSIG would be subtracted from the displayed PSID value while the pump is running. The Auto-zeroing will not be performed if either transducer is out of range.

The transducers operate from a +5VDC power source. This supply voltage is provided from the Power supply via the Microboard. Each transducer is connected to the Microboard with three wires. Two wires provide the +5VDC supply voltage and Ground (GND) and the remaining wire connects the transducer output to the Microboard. The voltage output of each transducer can be measured with a Voltmeter at the Microboard. Measurement should be made from the transducer output to Ground (GND). For example, the output of the Condenser transducer would be read from Microboard J8-21 (signal) to J8-22 (GND). To convert this output to a pressure, refer to the appropriate formula in FIG. 57. If the pressure is known, the transducer output can be predicted with the appropriate formula in FIG. 57.

If any of the displayed pressures do not appear to be correct, refer to the Diagnostics and Troubleshooting section of this book.

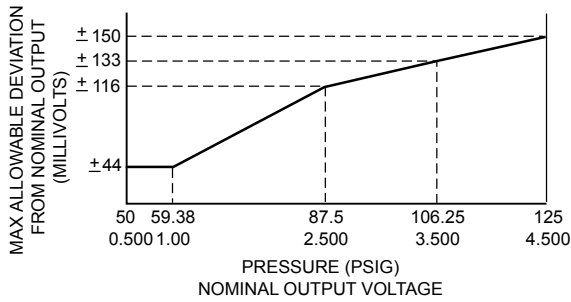

EVAPORATOR TRANSDUCER
 (R22 WATER APPLICATIONS)
 YORK PART NO. 025-28678-102
 025-28678-113

$$V = \frac{(P \times 4) - 162.5}{75} \quad P = \frac{(75 \times V) + 162.5}{4}$$

V = VOLTS DC P = PRESSURE (PSIG) LD05534A

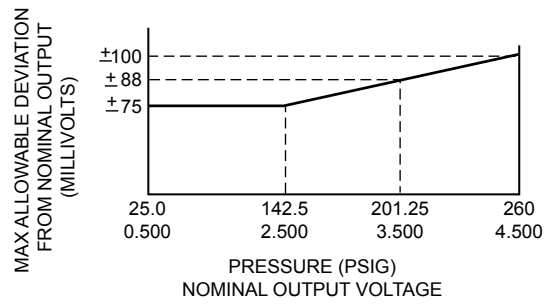

OIL PRESSURE (LOW SIDE)
 (R22 WATER & BRINE APPLICATIONS)
 YORK PART NO. 025-28678-004

$$V = \frac{P + 4.375}{58.75} \quad P = (58.75 \times V) - 4.375$$

V = VOLTS DC P = PRESSURE (PSIG) LD04099A

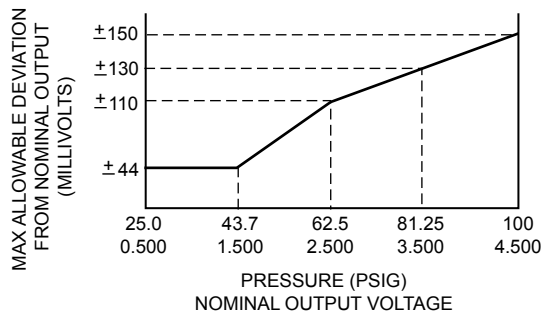

EVAPORATOR TRANSDUCER
 (R22 BRINE APPLICATIONS)
 YORK PART NO. 025-28678-103
 025-28678-114

$$V = \frac{P - 15.6}{18.75} \quad P = 18.75 \times V + 15.6$$

V = VOLTS DC P = PRESSURE (PSIG) LD05535A

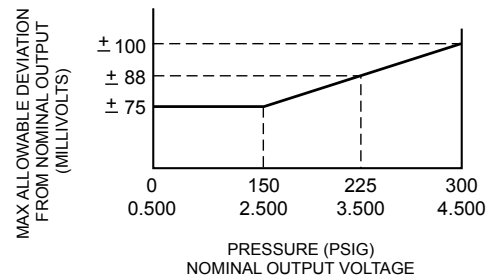

PRESSURE TRANSDUCER
 YORK PART NO. 025-28678-001
 025-28678-006

$$V = \frac{P + 37.5}{75} \quad P = (75 \times V) - 37.5$$

V = VOLTS DC P = PRESSURE (PSIG) LD05537A

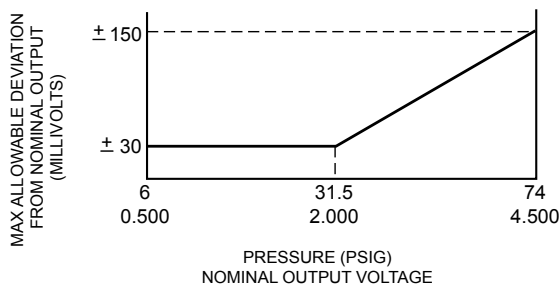

EVAPORATOR TRANSDUCER
 R134a WATER & BRINE APPLICATIONS
 YORK PART NO. 025-28678-112
 025-28678-104

$$V = \frac{P + 2.5}{17} \quad P = (17 \times V) - 2.5$$

V = VOLTS DC P = PRESSURE (PSIG) LD09969A

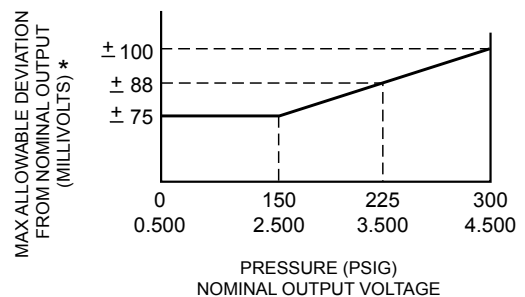

PRESSURE TRANSDUCER
 YORK PART NO. 025-39464-000
 025-40088-000

$$V = \frac{P + 37.5}{75} \quad P = (75 \times V) - 37.5$$

V = VOLTS DC P = PRESSURE (PSIG) LD09569a

FIG. 57 – PRESSURE TRANSDUCERS

PRESSURE TRANSDUCER APPLICATIONS CHART

TRANSDUCER PART NUMBER*	FUNCTION	R22 APPLICATION	
		WATER	BRINE
025-28678-001	CONDENSER, HIGH OIL	X	X
025-28678-102 025-28678-113	EVAPORATOR	X	
025-28678-103 025-28678-114	EVAPORATOR		X
025-28678-004	LOW OIL	X	X
		R134a	
025-28678-006	CONDENSER, HI & LO OIL	X	X
025-28678-112	EVAPORATOR	X	X
025-28678-104	EVAPORATOR	X	X
025-39464-000 025-40088-000	STALL DETECTION	X	X

***Note:** Transducers 025-28678-001, -004, -102 and -103, 104 have NPTF threads. Transducers 025-28678-006, -112, -113, -114 and 025-39464-000 and 025-40088-000 have straight threads with O-rings.

SECTION 18

TEMPERATURE THERMISTORS

(REFER TO FIG. 58 - 63)

System temperatures are sensed by **Thermistors**. There are two different thermistor types used to sense the various system temperatures. Each type has its own YORK part number. Part numbers are listed in YORK Renewal Parts List 160.54-RP2. The Return and Leaving Chilled Liquid, Return and Leaving Condenser Liquid, Drop Leg Refrigerant and Evaporator Temperatures are sensed by 3K Ohm thermistors. The Oil and Compressor Discharge temperatures are sensed by 50K Ohm thermistors.

The 3K Ohm thermistors are defined by the characteristic of being 3000 Ohms at 77°F (25°C). Similarly, the 50K Ohm thermistors are 50,000 Ohms at the same temperature. Both thermistor types vary their resistance as the sensed temperature varies. Both are negative temperature coefficient devices. That is, as the temperature increases, the resistance decreases. As the temperature decreases, the resistance increases.

The thermistors are connected to the Microboard. A +5VDC supply voltage is applied to one side of the thermistor. The other side of the thermistor is connected to Ground through a series resistor on the Microboard, thus forming a voltage divider network. The temperature applied to the thermistor determines the resistance value. The resistance value determines the amount of current that

will flow through the thermistor and thus the voltage drop across it. The Program reads this voltage at the input to the Microboard and converts it to a temperature value.

Each thermistor is connected to the Microboard with two wires. One wire supplies the +5VDC voltage and the other is the output of the thermistor. This output voltage can be measured with a Voltmeter. Measurement should be made from the thermistor output to Ground (Gnd). For example, the Leaving Chilled Liquid Temperature would be read from Microboard J9-20 (output) to Microboard TP1 (Gnd). To convert this voltage to a pressure, refer to the appropriate volts/temp chart as follows:

- Leaving Chilled Liquid Temperature – FIG. 58
- Return Chilled Liquid Temperature – FIG. 59
- Leaving and Return Condenser Liquid Temperature – FIG. 60
- Oil and Discharge Temperature – FIG. 61
- Drop Leg Refrigerant Temperature – FIG. 62
- Evaporator Refrigerant Temperature – FIG. 63

If any of the displayed pressures do not appear to be correct, refer to the “Diagnostics and Troubleshooting” section of this book.

FIG. 58 – LEAVING CHILLED LIQUID TEMPERATURE

Temp (°F)	Temp (°C)	Vin	Temp (°F)	Temp (°C)	Vin	Temp (°F)	Temp (°C)	Vin
9.90	-12.28	1.4280	15.13	-9.37	1.5957	20.17	-6.57	1.7634
10.00	-12.22	1.4310	15.22	-9.32	1.5987	20.26	-6.52	1.7664
10.09	-12.17	1.4341	15.32	-9.27	1.6018	20.35	-6.47	1.7695
10.19	-12.12	1.4371	15.41	-9.22	1.6048	20.44	-6.42	1.7725
10.29	-12.06	1.4402	15.50	-9.17	1.6079	20.53	-6.37	1.7756
10.39	-12.01	1.4432	15.60	-9.11	1.6109	20.62	-6.32	1.7786
10.48	-11.96	1.4463	15.69	-9.06	1.6140	20.71	-6.27	1.7817
10.58	-11.90	1.4493	15.78	-9.01	1.6170	20.80	-6.22	1.7847
10.68	-11.85	1.4423	15.87	-8.96	1.6201	20.89	-6.17	1.7878
10.77	-11.80	1.4554	15.97	-8.91	1.6231	20.98	-6.12	1.7908
10.87	-11.74	1.4584	16.06	-8.86	1.6262	21.07	-6.07	1.7939
10.97	-11.68	1.4615	16.15	-8.81	1.6292	21.16	-6.02	1.7969
11.06	-11.63	1.4645	16.24	-8.76	1.6322	21.25	-5.97	1.8000
11.16	-11.58	1.4676	16.34	-8.70	1.6353	21.34	-5.92	1.8030
11.25	-11.53	1.4706	16.43	-8.65	1.6383	21.43	-5.87	1.8060
11.35	-11.47	1.4737	16.52	-8.60	1.6414	21.52	-5.82	1.8091
11.45	-11.42	1.4767	16.61	-8.55	1.6444	21.61	-5.77	1.8121
11.54	-11.37	1.4798	16.70	-8.50	1.6475	21.70	-5.72	1.8152
11.64	-11.31	1.4828	16.80	-8.45	1.6505	21.79	-5.67	1.8182
11.73	-11.26	1.4859	16.89	-8.40	1.6536	21.88	-5.62	1.8213
11.83	-11.21	1.4889	16.98	-8.35	1.6566	21.97	-5.57	1.8243
11.93	-11.15	1.4920	17.07	-8.30	1.6597	22.06	-5.52	1.8274
12.02	-11.10	1.4950	17.16	-8.25	1.6627	22.15	-5.47	1.8304
12.12	-11.05	1.4981	17.26	-8.19	1.6658	22.24	-5.42	1.8335
12.21	-11.00	1.5011	17.35	-8.14	1.6688	22.33	-5.37	1.8365
12.31	-10.94	1.5042	17.44	-8.09	1.6719	22.42	-5.32	1.8396
12.40	-10.89	1.5072	17.53	-8.04	1.6749	22.51	-5.27	1.8426
12.50	-10.83	1.5103	17.63	-7.98	1.6780	22.60	-5.22	1.8457
12.59	-10.78	1.5133	17.72	-7.93	1.6810	22.69	-5.17	1.8487
12.69	-10.73	1.5164	17.81	-7.88	1.6841	22.78	-5.12	1.8518
12.78	-10.68	1.5194	17.90	-7.83	1.6871	22.87	-5.07	1.8548
12.88	-10.62	1.5225	17.99	-7.78	1.6902	22.96	-5.02	1.8579
12.97	-10.57	1.5255	18.08	-7.73	1.6932	23.04	-4.98	1.8609
13.07	-10.52	1.5286	18.17	-7.68	1.6963	23.13	-4.93	1.8640
13.16	-10.47	1.5316	18.26	-7.63	1.6993	23.22	-4.88	1.8670
13.26	-10.41	1.5347	18.35	-7.58	1.7024	23.31	-4.83	1.8701
13.35	-10.36	1.5377	18.44	-7.53	1.7054	23.40	-4.78	1.8731
13.45	-10.31	1.5408	18.54	-7.48	1.7085	23.49	-4.73	1.8762
13.54	-10.26	1.5438	18.63	-7.43	1.7115	23.58	-4.68	1.8792
13.64	-10.20	1.5469	18.72	-7.38	1.7146	23.67	-4.63	1.8823
13.73	-10.15	1.5499	18.81	-7.33	1.7176	23.75	-4.58	1.8853
13.83	-10.10	1.5530	18.90	-7.28	1.7207	23.84	-4.53	1.8884
13.92	-10.05	1.5560	18.99	-7.23	1.7237	23.93	-4.48	1.8914
14.01	-10.00	1.5591	19.08	-7.18	1.7268	24.02	-4.43	1.8945
14.11	-9.94	1.5621	19.17	-7.13	1.7298	24.11	-4.38	1.8975
14.20	-9.89	1.5652	19.26	-7.08	1.7329	24.20	-4.33	1.9006
14.29	-9.84	1.5682	19.36	-7.02	1.7359	24.29	-4.28	1.9036
14.39	-9.78	1.5713	19.45	-6.97	1.7390	24.37	-4.24	1.9067
14.48	-9.73	1.5743	19.54	-6.92	1.7420	24.46	-4.19	1.9097
14.57	-9.68	1.5774	19.63	-6.87	1.7451	24.55	-4.14	1.9128
14.67	-9.63	1.5804	19.72	-6.82	1.7481	24.64	-4.09	1.9158
14.76	-9.58	1.5835	19.81	-6.77	1.7512	24.73	-4.04	1.9189
14.85	-9.53	1.5865	19.90	-6.72	1.7542	24.82	-3.99	1.9219
14.95	-9.47	1.5896	19.99	-6.67	1.7573	24.91	-3.94	1.9250
15.04	-9.42	1.5926	20.08	-6.62	1.7603	24.99	-3.89	1.9280

FIG. 58 – LEAVING CHILLED LIQUID TEMPERATURE (CONT'D.)

Temp (°F)	Temp (°C)	Vin	Temp (°F)	Temp (°C)	Vin	Temp (°F)	Temp (°C)	Vin
25.08	-3.84	1.9311	29.92	-1.16	2.0988	34.73	1.52	2.2665
25.17	-3.79	1.9341	30.01	-1.11	2.1018	34.82	1.57	2.2695
25.26	-3.74	1.9372	30.10	-1.06	2.1049	34.91	1.62	2.2726
25.35	-3.69	1.9402	30.18	-1.01	2.1079	34.99	1.66	2.2756
25.43	-3.65	1.9433	30.27	-0.96	2.1110	35.08	1.71	2.2787
25.52	-3.60	1.9463	30.36	-0.91	2.1140	35.17	1.76	2.2817
25.61	-3.55	1.9494	30.45	-0.86	2.1171	35.26	1.81	2.2848
25.70	-3.50	1.9524	30.53	-0.82	2.1201	35.34	1.86	2.2878
25.79	-3.45	1.9555	30.62	-0.77	2.1232	35.43	1.91	2.2909
25.87	-3.41	1.9585	30.71	-0.72	2.1262	35.52	1.96	2.2939
25.96	-3.36	1.9616	30.79	-0.67	2.1293	35.51	1.95	2.2970
26.05	-3.31	1.9646	30.88	-0.62	2.1323	35.70	2.06	2.3000
26.14	-3.26	1.9677	30.97	-0.57	2.1354	35.78	2.10	2.3031
26.23	-3.21	1.9707	31.06	-0.52	2.1384	35.87	2.15	2.3061
26.31	-3.16	1.9738	31.14	-0.48	2.1415	35.96	2.20	2.3092
26.40	-3.11	1.9768	31.23	-0.43	2.1445	36.05	2.25	2.3122
26.49	-3.06	1.9798	31.32	-0.38	2.1476	36.13	2.29	2.3153
26.58	-3.01	1.9829	31.41	-0.33	2.1506	36.22	2.34	2.3183
26.67	-2.96	1.9859	31.49	-0.28	2.1536	36.31	2.39	2.3214
26.76	-2.91	1.9890	31.58	-0.23	2.1567	36.40	2.44	2.3244
26.84	-2.87	1.9920	31.67	-0.18	2.1597	36.48	2.49	2.3274
26.93	-2.82	1.9951	31.76	-0.13	2.1628	36.57	2.54	2.3305
27.02	-2.77	1.9981	31.84	-0.09	2.1658	36.66	2.59	2.3335
27.11	-2.72	2.0012	31.93	-0.04	2.1689	36.75	2.64	2.3366
27.20	-2.67	2.0042	32.02	0.01	2.1719	36.83	2.68	2.3396
27.28	-2.62	2.0073	32.10	0.06	2.1750	36.92	2.73	2.3427
27.37	-2.57	2.0103	32.19	0.11	2.1780	37.01	2.78	2.3457
27.46	-2.52	2.0134	32.28	0.16	2.1811	37.10	2.83	2.3488
27.55	-2.47	2.0164	32.37	0.21	2.1841	37.18	2.88	2.3518
27.64	-2.42	2.0195	32.45	0.25	2.1872	37.27	2.93	2.3549
27.73	-2.37	2.0225	32.54	0.30	2.1902	37.36	2.98	2.3579
27.81	-2.33	2.0256	32.63	0.35	2.1933	37.45	3.03	2.3610
27.90	-2.28	2.0286	32.72	0.40	2.1963	37.54	3.08	2.3640
27.99	-2.23	2.0317	32.81	0.45	2.1994	37.62	3.12	2.3671
28.08	-2.18	2.0347	32.89	0.49	2.2024	37.71	3.17	2.3701
28.17	-2.13	2.0378	32.98	0.54	2.2055	37.80	3.22	2.3732
28.25	-2.08	2.0408	33.07	0.59	2.2085	37.89	3.27	2.3762
28.34	-2.03	2.0439	33.16	0.64	2.2116	37.98	3.32	2.3793
28.43	-1.98	2.0469	33.24	0.69	2.2146	38.07	3.37	2.3823
28.52	-1.93	2.0500	33.33	0.74	2.2177	38.15	3.42	2.3854
28.61	-1.88	2.0530	33.42	0.79	2.2207	38.24	3.47	2.3884
28.69	-1.84	2.0561	33.51	0.84	2.2238	38.33	3.52	2.3915
28.78	-1.79	2.0591	33.59	0.88	2.2268	38.42	3.57	2.3945
28.87	-1.74	2.0622	33.68	0.93	2.2299	38.51	3.62	2.3976
28.96	-1.69	2.0652	33.77	0.98	2.2329	38.60	3.67	2.4006
29.04	-1.64	2.0683	33.86	1.03	2.2360	38.69	3.72	2.4037
29.13	-1.59	2.0713	33.94	1.08	2.2390	38.77	3.76	2.4067
29.22	-1.54	2.0744	34.03	1.13	2.2421	38.86	3.81	2.4098
29.31	-1.49	2.0774	34.12	1.18	2.2451	38.95	3.86	2.4128
29.39	-1.45	2.0805	34.21	1.23	2.2482	39.04	3.91	2.4159
29.48	-1.40	2.0835	34.29	1.27	2.2512	39.13	3.96	2.4189
29.57	1.35	2.0866	34.38	1.32	2.2543	39.22	4.01	2.4220
29.66	-1.30	2.0896	34.47	1.37	2.2573	39.30	4.06	2.4250
29.75	-1.25	2.0927	34.56	1.42	2.2604	39.39	4.11	2.4281
29.83	-1.21	2.0957	34.64	1.47	2.2634	39.48	4.16	2.4311

FIG. 58 – LEAVING CHILLED LIQUID TEMPERATURE (CONT'D.)

Temp (°F)	Temp (°C)	Vin	Temp (°F)	Temp (°C)	Vin	Temp (°F)	Temp (°C)	Vin
39.57	4.21	2.4342	44.46	6.92	2.6019	49.48	9.71	2.7696
39.66	4.26	2.4372	44.55	6.97	2.6049	49.57	9.76	2.7726
39.74	4.30	2.4403	44.64	7.02	2.6080	49.66	9.81	2.7757
39.83	4.35	2.4433	44.73	7.07	2.6110	49.75	9.86	2.7787
39.92	4.40	2.4464	44.82	7.12	2.6141	49.84	9.91	2.7818
40.01	4.45	2.4494	44.91	7.17	2.6171	49.94	9.97	2.7848
40.10	4.50	2.4525	45.00	7.22	2.6202	50.03	10.02	2.7879
40.19	4.55	2.4555	45.09	7.27	2.6232	50.12	10.07	2.7909
40.27	4.59	2.4586	45.18	7.32	2.6263	50.22	10.12	2.7940
40.36	4.64	2.4616	45.27	7.37	2.6293	50.31	10.17	2.7970
40.45	4.69	2.4647	45.36	7.42	2.6324	50.40	10.22	2.8001
40.54	4.74	2.4677	45.46	7.48	2.6354	50.50	10.28	2.8031
40.63	4.79	2.4708	45.55	7.53	2.6385	50.59	10.33	2.8062
40.71	4.84	2.4738	45.64	7.58	2.6415	50.68	10.38	2.8092
40.80	4.89	2.4769	45.73	7.63	2.6446	50.78	10.43	2.8123
40.89	4.94	2.4799	45.82	7.68	2.6476	50.87	10.48	2.8153
40.98	4.99	2.4830	45.91	7.73	2.6507	50.96	10.53	2.8184
41.07	5.04	2.4860	46.00	7.78	2.6537	51.06	10.59	2.8214
41.16	5.09	2.4891	46.09	7.83	2.6568	51.15	10.64	2.8245
41.24	5.13	2.4921	46.18	7.88	2.6598	51.24	10.69	2.8275
41.33	5.18	2.4952	46.27	7.93	2.6629	51.34	10.75	2.8306
41.42	5.23	2.4982	46.36	7.98	2.6659	51.43	10.80	2.8336
41.51	5.28	2.5012	46.45	8.03	2.6690	51.52	10.85	2.8367
41.60	5.33	2.5043	46.55	8.08	2.6720	51.62	10.90	2.8397
41.69	5.38	2.5073	46.64	8.13	2.6751	51.71	10.95	2.8428
41.78	5.43	2.5104	46.73	8.18	2.6781	51.80	11.00	2.8458
41.87	5.48	2.5134	46.82	8.23	2.6811	51.90	11.06	2.8458
41.96	5.53	2.5165	46.91	8.28	2.6842	51.99	11.11	2.8519
42.05	5.58	2.5195	47.00	8.33	2.6872	52.09	11.16	2.8549
42.14	5.63	2.5226	47.09	8.38	2.6903	52.18	11.21	2.8580
42.23	5.68	2.5256	47.18	8.43	2.6933	52.28	11.27	2.8610
42.31	5.73	2.5287	47.27	8.48	2.6964	52.37	11.32	2.8641
42.40	5.78	2.5317	47.36	8.53	2.6994	52.46	11.37	2.8671
42.49	5.83	2.5348	47.45	8.58	2.7025	52.56	11.42	2.8702
42.58	5.88	2.5378	47.55	8.64	2.7055	52.65	11.47	2.8732
42.67	5.93	2.5409	47.64	8.69	2.7086	52.75	11.53	2.8763
42.76	5.98	2.5439	47.73	8.74	2.7116	52.84	11.58	2.8793
42.85	6.03	2.5470	47.82	8.79	2.7147	52.94	11.63	2.8824
42.94	6.08	2.5500	47.91	8.84	2.7177	53.03	11.68	2.8854
43.03	6.13	2.5531	48.00	8.89	2.7208	53.13	11.74	2.8885
43.12	6.18	2.5561	48.09	8.94	2.7238	53.22	11.79	2.8915
43.21	6.23	2.5592	48.18	8.99	2.7269	53.32	11.85	2.8946
43.30	6.28	2.5622	48.27	9.04	2.7299	53.41	11.90	2.8976
43.39	6.33	2.5653	48.37	9.10	2.7330	53.51	11.95	2.9007
43.48	6.38	2.5683	48.46	9.15	2.7360	53.60	12.00	2.9037
43.57	6.43	2.5714	48.55	9.20	2.7391	53.70	12.06	2.9068
43.65	6.47	2.5744	48.64	9.25	2.7421	53.79	12.11	2.9098
43.74	6.52	2.5775	48.74	9.30	2.7452	53.89	12.16	2.9129
43.83	6.57	2.5805	48.83	9.35	2.7482	53.98	12.21	2.9159
43.92	6.62	2.5836	48.92	9.40	2.7513	54.08	12.27	2.9190
44.01	6.67	2.5866	49.01	9.45	2.7543	54.17	12.32	2.9220
44.10	6.72	2.5897	49.11	9.51	2.7574	54.27	12.37	2.9251
44.19	6.77	2.5927	49.20	9.56	2.7604	54.36	12.42	2.9281
44.28	6.82	2.5958	49.29	9.61	2.7635	54.46	12.48	2.9312
44.37	6.87	2.5988	49.38	9.66	2.7665	54.55	12.53	2.9342

FIG. 58 – LEAVING CHILLED LIQUID TEMPERATURE (CONT'D.)

Temp (°F)	Temp (°C)	Vin	Temp (°F)	Temp (°C)	Vin	Temp (°F)	Temp (°C)	Vin
54.65	12.58	2.9373	60.05	15.58	3.1050	65.75	18.75	3.2727
54.74	12.63	2.9403	60.15	15.64	3.1080	65.85	18.81	3.2757
54.84	12.69	2.9403	60.25	15.70	3.1111	65.96	18.87	3.2788
54.93	12.74	2.9464	60.36	15.76	3.1141	66.06	18.92	3.2818
55.03	12.80	2.9495	60.46	15.81	3.1172	66.17	18.98	3.2849
55.12	12.85	2.9525	60.56	15.87	3.1202	66.28	19.05	3.2879
55.22	12.90	2.9556	60.66	15.92	3.1233	66.39	19.11	3.2910
55.32	12.96	2.9586	60.76	15.98	3.1263	66.49	19.16	3.2940
55.41	13.01	2.9617	60.86	16.03	3.1294	66.60	19.22	3.2971
55.51	13.06	2.9647	60.96	16.09	3.1324	66.71	19.28	3.3001
55.61	13.12	2.9678	61.06	16.15	3.1355	66.82	19.35	3.3032
55.70	13.17	2.9708	61.17	16.21	3.1385	66.93	19.41	3.3062
55.80	13.22	2.9739	61.27	16.26	3.1416	67.03	19.46	3.3093
55.90	13.28	2.9769	61.37	16.32	3.1446	67.14	19.52	3.3123
56.00	13.33	2.9800	61.47	16.37	3.1477	67.25	19.58	3.3154
56.09	13.38	2.9830	61.57	16.43	3.1507	67.36	19.65	3.3184
56.19	13.44	2.9861	61.67	16.48	3.1538	67.47	19.71	3.3215
56.29	13.50	2.9891	61.78	16.55	3.1568	67.58	19.77	3.3245
56.39	13.55	2.9922	61.88	16.60	3.1599	67.68	19.82	3.3276
56.48	13.60	2.9952	61.98	16.66	3.1629	67.79	19.88	3.3306
56.58	13.66	2.9983	62.08	16.71	3.1660	67.90	19.95	3.3337
56.68	13.71	3.0013	62.18	16.77	3.1690	68.01	20.01	3.3367
56.78	13.77	3.0044	62.28	16.82	3.1721	68.12	20.07	3.3398
56.87	13.82	3.0074	62.39	16.88	3.1751	68.23	20.13	3.3428
56.97	13.87	3.0105	62.49	16.94	3.1782	68.34	20.19	3.3459
57.07	13.93	3.0135	62.59	17.00	3.1812	68.45	20.25	3.3489
57.17	13.98	3.0166	62.69	17.05	3.1843	68.56	20.31	3.3520
57.26	14.03	3.0196	62.80	17.11	3.1873	68.67	20.37	3.3550
57.36	14.09	3.0227	62.90	17.17	3.1904	68.78	20.43	3.3581
57.46	14.15	3.0257	63.01	17.23	3.1934	68.90	20.50	3.3611
57.56	14.20	3.0287	63.11	17.28	3.1965	69.01	20.56	3.3642
57.66	14.26	3.0318	63.22	17.35	3.1995	69.12	20.62	3.3672
57.76	14.31	3.0348	63.32	17.40	3.2025	69.23	20.68	3.3703
57.86	14.37	3.0379	63.43	17.46	3.2056	69.34	20.75	3.3733
57.96	14.42	3.0409	63.53	17.52	3.2086	69.45	20.81	3.3763
58.06	14.48	3.0440	63.63	17.57	3.2117	69.56	20.87	3.3794
58.15	14.53	3.0470	63.74	17.63	3.2147	69.67	20.93	3.3824
58.25	14.58	3.0501	63.84	17.69	3.2178	69.78	20.99	3.3855
58.35	14.64	3.0531	63.95	17.75	3.2208	69.89	21.05	3.3885
58.45	14.70	3.0562	64.05	17.81	3.2239	70.01	21.12	3.3916
58.55	14.75	3.0592	64.16	17.87	3.2269	70.12	21.18	3.3946
58.65	14.81	3.0623	64.26	17.92	3.2300	70.24	21.25	3.3977
58.75	14.86	3.0653	64.37	17.98	3.2330	70.35	21.31	3.4007
58.85	14.92	3.0684	64.47	18.04	3.2361	70.46	21.37	3.4038
58.95	14.97	3.0714	64.58	18.10	3.2391	70.58	21.44	3.4068
59.05	15.03	3.0745	64.68	18.16	3.2422	70.69	21.50	3.4099
59.15	15.08	3.0775	64.79	18.22	3.2452	70.80	21.56	3.4129
59.25	15.14	3.0806	64.90	18.28	3.2483	70.92	21.62	3.4160
59.35	15.20	3.0836	65.00	18.33	3.2513	71.03	21.69	3.4190
59.45	15.25	3.0867	65.11	18.40	3.2544	71.15	21.75	3.4221
59.55	15.31	3.0897	65.21	18.45	3.2574	71.26	21.81	3.4251
59.65	15.36	3.0928	65.32	18.51	3.2605	71.37	21.87	3.4282
59.75	15.42	3.0958	65.43	18.57	3.2635	71.49	21.94	3.4312
59.85	15.47	3.0989	65.53	18.63	3.2666	71.60	22.00	3.4343
59.95	15.53	3.1019	65.64	18.69	3.2696	71.72	22.07	3.4373

FIG. 58 – LEAVING CHILLED LIQUID TEMPERATURE (CONT'D.)

Temp (°F)	Temp (°C)	Vin	Temp (°F)	Temp (°C)	Vin
71.83	22.13	3.4404	78.42	25.79	3.6081
71.95	22.20	3.4434	78.55	25.86	3.6111
72.06	22.26	3.4465	78.67	25.93	3.6142
72.18	22.32	3.4495	78.80	26.00	3.6172
72.29	22.39	3.4526	78.93	26.07	3.6203
72.41	22.45	3.4556	79.05	26.14	3.6233
72.52	22.51	3.4587	79.18	26.21	3.6264
72.64	22.58	3.4617	79.31	26.29	3.6294
72.75	22.64	3.4648	79.44	26.36	3.6325
72.87	22.71	3.4678	79.57	26.43	3.6355
72.98	22.77	3.4709	79.69	26.50	3.6386
73.10	22.84	3.4739	79.82	26.57	3.6416
73.21	22.90	3.4770	79.95	26.64	3.6447
73.33	22.96	3.4800	80.08	26.71	3.6477
73.44	23.02	3.4831	80.20	26.78	3.6508
73.56	23.09	3.4861	80.33	26.85	3.6538
73.68	23.16	3.4892	80.46	26.92	3.6569
73.80	23.22	3.4922	80.59	27.00	3.6599
73.92	23.29	3.4953	80.72	27.07	3.6630
74.04	23.36	3.4983	80.85	27.14	3.6660
74.16	23.42	3.5014	80.98	27.21	3.6691
74.28	23.49	3.5044	81.11	27.29	3.6721
74.40	23.56	3.5075	81.24	27.36	3.6752
74.52	23.62	3.5105	81.37	27.43	3.6782
74.64	23.69	3.5136	81.50	27.50	3.6813
74.75	23.75	3.5166	81.63	27.57	3.6843
74.87	23.82	3.5197	81.76	27.65	3.6874
74.99	23.89	3.5227	81.89	27.72	3.6904
75.11	23.95	3.5258	82.02	27.79	3.6935
75.23	24.02	3.5288	82.15	27.86	3.6965
75.35	24.09	3.5319	82.28	27.94	3.6996
75.47	24.15	3.5349	82.41	28.01	3.7026
75.60	24.22	3.5380			
75.72	24.29	3.5410			
75.84	24.36	3.5441			
75.96	24.42	3.5471			
76.08	24.49	3.5501			
76.20	24.56	3.5532			
76.32	24.62	3.5562			
76.44	24.69	3.5593			
76.57	24.76	3.5623			
76.69	24.83	3.5654			
76.81	24.90	3.5684			
76.93	24.96	3.5715			
77.05	25.03	3.5745			
77.18	25.10	3.5776			
77.30	25.17	3.5806			
77.43	25.24	3.5837			
77.55	25.31	3.5867			
77.68	25.38	3.5898			
77.80	25.45	3.5928			
77.93	25.52	3.5959			
78.05	25.59	3.5989			
78.17	25.65	3.6020			
78.30	25.72	3.6050			

FIG. 59 – RETURN CHILLED LIQUID TEMPERATURE

Temp (°F)	Temp (°C)	Vin	Temp (°F)	Temp (°C)	Vin	Temp (°F)	Temp (°C)	Vin
15.01	-9.44	1.5918	23.03	-4.98	1.8604	30.78	-0.68	2.1289
15.16	-9.36	1.5967	23.17	-4.91	1.8652	30.92	-0.60	2.1338
15.31	-9.27	1.6016	23.31	-4.83	1.8701	31.06	-0.52	2.1387
15.46	-9.19	1.6064	23.45	-4.75	1.8750	31.20	-0.44	2.1436
15.61	-9.11	1.6113	23.60	-4.67	1.8799	31.34	-0.37	2.1484
15.76	-9.02	1.6162	23.74	-4.59	1.8848	31.48	-0.29	2.1533
15.91	-8.94	1.6211	23.88	-4.51	1.8896	31.62	-0.21	2.1582
16.05	-8.86	1.6260	24.02	-4.43	1.8945	31.76	-0.13	2.1631
16.20	-8.78	1.6309	24.16	-4.36	1.8994	31.90	-0.06	2.1680
16.35	-8.70	1.6357	24.31	-4.27	1.9043	32.04	0.02	2.1729
16.50	-8.61	1.6406	24.45	-4.19	1.9092	32.18	0.10	2.1777
16.64	-8.53	1.6455	24.59	-4.12	1.9141	32.32	0.18	2.1826
16.79	-8.45	1.6504	24.73	-4.04	1.9189	32.46	0.26	2.1875
16.94	-8.37	1.6553	24.87	-3.96	1.9238	32.60	0.33	2.1924
17.09	-8.28	1.6602	25.01	-3.88	1.9287	32.74	0.41	2.1973
17.23	-8.21	1.6650	25.16	-3.80	1.9336	32.88	0.49	2.2021
17.38	-8.12	1.6699	25.30	-3.72	1.9385	33.02	0.57	2.2070
17.53	-8.04	1.6748	25.44	-3.64	1.9434	33.16	0.64	2.2119
17.68	-7.96	1.6797	25.58	-3.57	1.9482	33.30	0.72	2.2168
17.82	-7.88	1.6846	25.72	-3.49	1.9531	33.44	0.80	2.2217
17.97	-7.80	1.6895	25.86	-3.41	1.9580	33.59	0.88	2.2266
18.11	-7.72	1.6943	26.00	-3.33	1.9629	33.73	0.96	2.2314
18.26	-7.63	1.6992	26.14	-3.26	1.9678	33.87	1.04	2.2363
18.41	-7.55	1.7041	26.28	-3.18	1.9727	34.01	1.12	2.2412
18.55	-7.47	1.7090	26.42	-3.10	1.9775	34.15	1.19	2.2461
18.70	-7.39	1.7139	26.56	-3.02	1.9824	34.29	1.27	2.2510
18.84	-7.31	1.7188	26.71	-2.94	1.9873	34.43	1.35	2.2559
18.99	-7.23	1.7236	26.85	-2.86	1.9922	34.57	1.43	2.2607
19.13	-7.15	1.7285	26.99	-2.78	1.9971	34.71	1.51	2.2656
19.28	-7.07	1.7334	27.13	-2.71	2.0020	34.85	1.58	2.2705
19.43	-6.98	1.7383	27.27	-2.63	2.0068	34.99	1.66	2.2754
19.57	-6.91	1.7432	27.41	-2.55	2.0117	35.13	1.74	2.2803
19.71	-6.83	1.7480	27.55	-2.47	2.0166	35.27	1.82	2.2852
19.86	-6.74	1.7529	27.70	-2.39	2.0215	35.41	1.89	2.2900
20.00	-6.67	1.7578	27.84	-2.31	2.0264	35.55	1.97	2.2949
20.15	-6.58	1.7627	27.98	-2.23	2.0313	35.69	2.05	2.2998
20.29	-6.51	1.7676	28.12	-2.16	2.0361	35.83	2.13	2.3047
20.44	-6.42	1.7725	28.26	-2.08	2.0410	35.97	2.21	2.3096
20.58	-6.34	1.7773	28.40	-2.00	2.0459	36.11	2.28	2.3145
20.73	-6.26	1.7822	28.54	-1.92	2.0508	36.25	2.36	2.3193
20.87	-6.18	1.7871	28.68	-1.84	2.0557	36.39	2.44	2.3242
21.01	-6.11	1.7920	28.82	-1.77	2.0605	36.53	2.52	2.3291
21.16	-6.02	1.7969	28.96	-1.69	2.0654	36.67	2.59	2.3340
21.30	-5.94	1.8018	29.10	-1.61	2.0703	36.81	2.67	2.3389
21.45	-5.86	1.8066	29.24	-1.53	2.0752	36.95	2.75	2.3438
21.59	-5.78	1.8115	29.38	-1.46	2.0801	37.09	2.83	2.3486
21.73	-5.71	1.8164	29.52	-1.38	2.0850	37.23	2.91	2.3535
21.88	-5.62	1.8213	29.66	-1.30	2.0898	37.37	2.98	2.3584
22.02	-5.54	1.8262	29.80	-1.22	2.0947	37.51	3.06	2.3633
22.17	-5.46	1.8311	29.94	-1.14	2.0996	37.66	3.14	2.3682
22.31	-5.38	1.8359	30.08	-1.07	2.1045	37.80	3.22	2.3730
22.45	-5.31	1.8408	30.22	-0.99	2.1094	37.94	3.30	2.3779
22.60	-5.22	1.8457	30.36	-0.91	2.1143	38.08	3.38	2.3828
22.74	-5.14	1.8506	30.50	-0.83	2.1191	38.22	3.46	2.3877
22.88	-5.07	1.8555	30.64	-0.76	2.1240	38.36	3.53	2.3926

FIG. 59 – RETURN CHILLED LIQUID TEMPERATURE (CONT'D.)

Temp (°F)	Temp (°C)	Vin	Temp (°F)	Temp (°C)	Vin	Temp (°F)	Temp (°C)	Vin
38.51	3.62	2.3975	46.37	7.98	2.6660	54.56	12.53	2.9346
38.65	3.69	2.4023	46.51	8.06	2.6709	54.72	12.62	2.9395
38.79	3.77	2.4072	46.66	8.15	2.6758	54.87	12.71	2.9443
38.93	3.85	2.4121	46.80	8.22	2.6807	55.02	12.79	2.9492
39.07	3.93	2.4170	46.95	8.31	2.6855	55.17	12.87	2.9541
39.21	4.01	2.4219	47.09	8.38	2.6904	55.33	12.96	2.9590
39.35	4.08	2.4268	47.24	8.47	2.6953	55.48	13.05	2.9639
39.50	4.17	2.4316	47.39	8.55	2.7002	55.64	13.13	2.9688
39.64	4.24	2.4365	47.53	8.63	2.7051	55.79	13.22	2.9736
39.78	4.32	2.4414	47.68	8.71	2.7100	55.95	13.31	2.9785
39.92	4.40	2.4463	47.82	8.79	2.7148	56.11	13.40	2.9834
40.06	4.48	2.4512	47.97	8.87	2.7197	56.26	13.48	2.9983
40.20	4.56	2.4561	48.11	8.95	2.7246	56.42	13.57	2.9932
40.34	4.63	2.4609	48.26	9.03	2.7295	56.57	13.65	2.9980
40.48	4.71	2.4658	48.41	9.12	2.7344	56.73	13.74	3.0029
40.62	4.79	2.4707	48.56	9.20	2.7393	56.89	13.83	3.0078
40.76	4.87	2.4756	48.70	9.28	2.7441	57.04	13.91	3.0127
40.91	4.95	2.4805	48.85	9.36	2.7490	57.20	14.00	3.0176
41.05	5.03	2.4854	49.00	9.45	2.7539	57.36	14.09	3.0225
41.19	5.11	2.4902	49.15	9.53	2.7588	57.51	14.17	3.0273
41.33	5.18	2.4951	49.30	9.61	2.7637	57.67	14.26	3.0322
41.48	5.27	2.5000	49.44	9.69	2.7686	57.83	14.35	3.0371
41.62	5.34	2.5049	49.59	9.77	2.7734	57.99	14.44	3.0420
41.76	5.42	2.5098	49.74	9.86	2.7783	58.15	14.53	3.0469
41.90	5.50	2.5146	49.89	9.94	2.7832	58.31	14.62	3.0518
42.05	5.58	2.5195	50.04	10.02	2.7881	58.47	14.71	3.0566
42.19	5.66	2.5244	50.19	10.11	2.7930	58.62	14.79	3.0615
42.33	5.74	2.5293	50.34	10.19	2.7979	58.78	14.88	3.0664
42.48	5.82	2.5342	50.48	10.27	2.8027	58.94	14.97	3.0713
42.62	5.90	2.5391	50.63	10.35	2.8076	59.10	15.06	3.0762
42.76	5.98	2.5439	50.78	10.43	2.8125	59.26	15.15	3.0811
42.90	6.06	2.5488	50.93	10.52	2.8174	59.42	15.23	3.0859
43.05	6.14	2.5537	51.08	10.60	2.8223	59.59	15.33	3.0908
43.19	6.22	2.5586	51.23	10.68	2.8271	59.75	15.42	3.0957
43.33	6.29	2.5635	51.38	10.77	2.8320	59.91	15.51	3.1006
43.48	6.38	2.5684	51.53	10.85	2.8369	60.07	15.60	3.1055
43.62	6.46	2.5732	51.68	10.93	2.8418	60.23	15.68	3.1104
43.76	6.53	2.5781	51.83	11.02	2.8467	60.39	15.77	3.1152
43.91	6.62	2.5830	51.98	11.10	2.8516	60.55	15.86	3.1201
44.05	6.69	2.5879	52.13	11.18	2.8564	60.72	15.96	3.1250
44.19	6.77	2.5928	52.28	11.27	2.8613	60.88	16.05	3.1299
44.34	6.86	2.5977	52.44	11.36	2.8662	61.04	16.13	3.1348
44.48	6.93	2.6025	52.59	11.44	2.8711	61.20	16.22	3.1396
44.62	7.01	2.6074	52.74	11.52	2.8760	61.37	16.32	3.1445
44.77	7.10	2.6123	52.89	11.61	2.8809	61.53	16.41	3.1494
44.91	7.17	2.6172	53.04	11.69	2.8857	61.69	16.50	3.1543
45.06	7.26	2.6221	53.19	11.77	2.8906	61.85	16.58	3.1592
45.20	7.33	2.6270	53.34	11.86	2.8955	62.02	16.68	3.1641
45.35	7.42	2.6318	53.50	11.95	2.9004	62.18	16.77	3.1689
45.49	7.50	2.6367	53.65	12.03	2.9053	62.34	16.86	3.1738
45.64	7.58	2.6416	53.80	12.11	2.9102	62.51	16.95	3.1787
45.79	7.66	2.6465	53.95	12.20	2.0150	62.67	17.04	3.1836
45.93	7.74	2.6514	54.11	12.28	2.9199	62.84	17.13	3.1885
46.08	7.82	2.6563	54.26	12.37	2.9248	63.01	17.23	3.1934
46.22	7.90	2.6611	54.41	12.45	2.9297	63.17	17.32	3.1882

FIG. 59 – RETURN CHILLED LIQUID TEMPERATURE (CONT'D.)

Temp (°F)	Temp (°C)	Vin	Temp (°F)	Temp (°C)	Vin
63.34	17.41	3.2031	73.01	22.79	3.4717
63.51	17.51	3.2080	73.20	22.89	3.4766
63.68	17.60	3.2129	73.38	22.99	3.4814
63.84	17.69	3.2178	73.57	23.10	3.4863
64.01	17.78	3.2227	73.76	23.20	3.4912
64.18	17.88	3.2275	73.95	23.31	3.4961
64.34	17.97	3.2324	74.14	23.41	3.5010
64.51	18.06	3.2373	74.33	23.52	3.5059
64.68	18.16	3.2422	74.53	23.63	3.5107
64.85	18.25	3.2471	74.72	23.74	3.5156
65.02	18.35	3.2520	74.91	23.84	3.5205
65.19	18.44	3.2568	75.10	23.95	3.5254
65.36	18.53	3.2617	75.29	24.05	3.5303
65.53	18.63	3.2666	75.48	24.16	3.5352
65.70	18.72	3.2715	75.68	24.27	3.5400
65.87	18.82	3.2764	75.87	24.37	3.5449
66.04	18.91	3.2813	76.07	24.49	3.5498
66.21	19.01	3.2861	76.26	24.59	3.5547
66.39	19.11	3.2910	76.46	24.70	3.5596
66.56	19.20	3.2959	76.65	24.81	3.5645
66.73	19.30	3.3008	76.84	24.91	3.5693
66.91	19.40	3.3057	77.04	25.02	3.5742
67.08	19.49	3.3105	77.24	25.14	3.5791
67.25	19.58	3.3154	77.44	25.25	3.5840
67.43	19.68	3.3203	77.64	25.36	3.5889
67.60	19.78	3.3252	77.84	25.47	3.5938
67.77	19.87	3.3301	78.04	25.58	3.5986
67.95	19.97	3.3350	78.24	25.69	3.6035
68.12	20.07	3.3398	78.44	25.80	3.6084
68.30	20.17	3.3447	78.64	25.91	3.6133
68.48	20.27	3.3496	78.84	26.02	3.6182
68.66	20.37	3.3545	79.04	26.14	3.6230
68.83	20.46	3.3594	79.25	26.25	3.6279
69.01	20.56	3.3643	79.45	26.36	3.6328
69.19	20.66	3.3691	79.66	26.48	3.6377
69.36	20.76	3.3740	79.86	26.59	3.6426
69.54	20.86	3.3789	80.07	26.71	3.6475
69.72	20.96	3.3838	80.27	26.82	3.6523
69.90	21.06	3.3887	80.48	26.94	3.6572
70.08	21.16	3.3936	80.68	27.05	3.6621
70.26	21.26	3.3984	80.89	27.16	3.6670
70.45	21.36	3.4033	81.10	27.28	3.6719
70.63	21.46	3.4082	81.31	27.40	3.6768
70.81	21.56	3.4131	81.52	27.51	3.6816
70.99	21.66	3.4180	81.72	27.62	3.6865
71.17	21.76	3.4229	81.93	27.74	3.6914
71.36	21.87	3.4277	82.14	27.86	3.6963
71.54	21.97	3.4326	82.35	27.97	3.7012
71.72	22.07	3.4375	82.56	28.09	3.7061
71.91	22.17	3.4424			
72.09	22.27	3.4473			
72.28	22.38	3.4521			
72.46	22.48	3.4570			
72.64	22.58	3.4619			
72.83	22.69	3.4668			

FIG. 60 – RETURN AND LEAVING CONDENSING WATER

Temp (°F)	Temp (°C)	Vin	Temp (°F)	Temp (°C)	Vin	Temp (°F)	Temp (°C)	Vin
40.12	4.51	1.8408	48.39	9.11	2.1094	56.61	13.67	2.3779
40.27	4.59	1.8457	48.54	9.19	2.1143	56.76	13.76	2.3828
40.42	4.68	1.8506	48.69	9.27	2.1191	56.91	13.84	2.3877
40.58	4.77	1.8555	48.84	9.36	2.1240	57.06	13.92	2.3926
40.73	4.85	1.8604	48.99	9.44	2.1289	57.21	14.01	2.3975
40.88	4.93	1.8652	49.14	9.52	2.1338	57.36	14.09	2.4023
41.03	5.02	1.8701	49.29	9.61	2.1387	57.51	14.17	2.4072
41.18	5.10	1.8750	49.44	9.69	2.1436	57.66	14.26	2.4121
41.33	5.18	1.8799	49.59	9.77	2.1484	57.81	14.34	2.4170
41.48	5.27	1.8848	49.74	9.86	2.1533	57.97	14.43	2.4219
41.64	5.36	1.8896	49.89	9.94	2.1582	58.12	14.51	2.4268
41.79	5.44	1.8945	50.03	10.02	2.1631	58.27	14.60	2.4316
41.94	5.52	1.8994	50.18	10.10	2.1680	58.42	14.68	2.4365
42.09	5.61	1.9043	50.33	10.18	2.1729	58.57	14.76	2.4414
42.24	5.69	1.9092	50.48	10.27	2.1777	58.72	14.85	2.4463
42.39	5.77	1.9141	50.63	10.35	2.1826	58.87	14.93	2.4512
42.54	5.86	1.9189	50.78	10.43	2.1875	59.02	15.01	2.4561
42.70	5.94	1.9238	50.93	10.52	2.1924	59.17	15.10	2.4609
42.85	6.03	1.9287	51.08	10.60	2.1973	59.33	15.18	2.4658
43.00	6.11	1.9336	51.23	10.68	2.2021	59.48	15.27	2.4707
43.15	6.19	1.9385	51.38	10.77	2.2070	59.63	15.35	2.4756
43.30	6.28	1.9434	51.53	10.85	2.2119	59.78	15.43	2.4805
43.45	6.36	1.9482	51.68	10.93	2.1268	59.93	15.52	2.4854
43.60	6.44	1.9531	51.83	11.02	2.2217	60.09	15.61	2.4902
43.75	6.53	1.9580	51.97	11.10	2.2266	60.24	15.69	2.4951
43.90	6.61	1.9629	52.12	11.18	2.2314	60.39	15.77	2.5000
44.05	6.69	1.9678	52.27	11.26	2.2363	60.54	15.86	2.5049
44.20	6.78	1.9727	52.42	11.35	2.2412	60.69	15.94	2.5098
44.35	6.86	1.9775	52.57	11.43	2.2461	60.85	16.03	2.5146
44.50	6.95	1.9824	52.72	11.51	2.2510	61.00	16.11	2.5195
44.65	7.03	1.9873	52.87	11.60	2.2559	61.15	16.20	2.5244
44.80	7.11	1.9922	53.02	11.68	2.2607	61.30	16.28	2.5293
44.95	7.20	1.9971	53.17	11.76	2.2656	61.45	16.36	2.5342
45.10	7.28	2.0020	53.32	11.85	2.2705	61.61	16.45	2.5391
45.25	7.36	2.0068	53.47	11.93	2.2754	61.76	16.53	2.5439
45.40	7.45	2.0117	53.62	12.01	2.2803	61.91	16.62	2.5488
45.55	7.53	2.0166	53.77	12.10	2.2852	62.06	16.70	2.5537
45.70	7.61	2.0215	53.92	12.18	2.2900	62.21	16.78	2.5586
45.85	7.70	2.0264	54.07	12.26	2.2949	62.36	16.87	2.5635
46.00	7.78	2.0313	54.21	12.34	2.2998	62.52	16.96	2.5684
46.15	7.86	2.0361	54.36	12.42	2.3047	62.67	17.04	2.5732
46.30	7.95	2.0410	54.51	12.51	2.3096	62.82	17.12	2.5781
46.45	8.03	2.0459	54.66	12.59	2.3145	62.98	17.21	2.5830
46.60	8.11	2.0508	54.81	12.67	2.3193	63.13	17.30	2.5879
46.75	8.20	2.0557	54.96	12.76	2.3242	63.29	17.38	2.5928
46.90	8.28	2.0605	55.11	12.84	2.3291	63.44	17.47	2.5977
47.05	8.36	2.0654	55.26	12.92	2.3340	63.59	17.55	2.6025
47.20	8.45	2.0703	55.41	13.01	2.3389	63.75	17.64	2.6074
47.35	8.53	2.0752	55.56	13.09	2.3438	63.90	17.72	2.6123
47.50	8.61	2.0801	55.71	13.17	2.3486	64.06	17.81	2.6172
47.65	8.70	2.0850	55.86	13.26	2.3535	64.21	17.90	2.6221
47.79	8.77	2.0898	56.01	13.34	2.3584	64.36	17.98	2.6270
47.94	8.86	2.0947	56.16	13.42	2.3633	64.52	18.07	2.6318
48.09	8.94	2.0996	56.31	13.51	2.3682	64.52	18.07	2.6367
48.24	9.02	2.1045	56.46	13.59	2.3730	64.83	18.24	2.6416

FIG. 60 – RETURN AND LEAVING CONDENSING WATER (CONT'D.)

Temp (°F)	Temp (°C)	Vin	Temp (°F)	Temp (°C)	Vin	Temp (°F)	Temp (°C)	Vin
64.98	18.32	2.6465	73.71	23.17	2.9150	83.04	28.36	3.1836
65.14	18.41	2.6514	73.87	23.26	2.9199	83.22	28.46	3.1885
65.29	18.50	2.6563	74.04	23.36	2.9248	83.39	28.55	3.1934
65.45	18.58	2.6611	74.20	23.45	2.9297	83.57	28.65	3.1982
65.60	18.67	2.6660	74.37	23.54	2.9346	83.75	28.75	3.2031
65.76	18.76	2.6709	74.53	23.63	2.9395	83.93	28.85	3.2080
65.91	18.84	2.6758	74.70	23.72	2.9443	84.10	28.95	3.2129
66.07	18.93	2.6807	74.86	23.81	2.9492	84.28	29.05	3.2178
66.22	19.01	2.6855	75.03	23.91	2.9541	84.46	29.15	3.2227
66.38	19.10	2.6904	75.19	24.00	2.9590	84.65	29.25	3.2275
66.54	19.19	2.6953	75.36	24.09	2.9639	84.83	29.35	3.2324
66.69	19.27	2.7002	75.52	24.18	2.9688	85.01	29.45	3.2373
66.85	19.36	2.7051	75.69	24.27	2.9736	85.19	29.55	3.2422
66.00	18.89	2.7100	75.85	24.36	2.9785	85.37	29.65	3.2471
67.16	19.53	2.7148	76.02	24.46	2.9834	85.55	29.75	3.2520
67.32	19.62	2.7197	76.19	24.55	2.9883	85.73	29.85	3.2568
67.47	19.71	2.7246	76.35	24.64	2.9932	85.92	29.96	3.2617
67.63	19.80	2.7295	76.52	24.74	2.9980	86.10	30.06	3.2666
67.78	19.88	2.7344	76.69	24.83	3.0029	86.28	30.16	3.2715
67.94	19.97	2.7393	76.85	24.92	3.0078	86.47	30.26	3.2764
68.10	20.06	2.7441	77.02	25.01	3.0127	86.65	30.36	3.2813
68.26	20.15	2.7490	77.19	25.11	3.0176	86.84	30.47	3.2861
68.41	20.23	2.7539	77.36	25.20	3.0225	87.02	30.57	3.2910
68.57	20.32	2.7588	77.53	25.30	3.0273	87.21	30.67	3.2959
68.73	20.41	2.7637	77.70	25.39	3.0322	87.39	30.77	3.3008
68.89	20.50	2.7686	77.86	25.48	3.0371	87.58	30.88	3.3057
69.05	20.58	2.7734	78.03	25.57	3.0420	87.76	30.98	3.3105
69.21	20.67	2.7783	78.20	25.67	3.0469	87.95	31.09	3.3154
69.36	20.76	2.7832	78.37	25.76	3.0518	88.13	31.19	3.3203
69.52	20.85	2.7881	78.54	25.86	3.0566	88.32	31.29	3.3252
69.68	20.94	2.7930	78.71	25.95	3.0615	88.51	31.40	3.3301
69.84	21.02	2.7979	78.88	26.05	3.0664	88.70	31.50	3.3350
70.00	21.11	2.8027	79.05	26.14	3.0713	88.88	31.60	3.3398
70.16	21.20	2.8076	79.22	26.24	3.0762	89.07	31.71	3.3447
70.32	21.29	2.8125	79.40	26.34	3.0811	89.26	31.81	3.3496
70.48	21.38	2.8174	79.57	26.43	3.0859	89.44	31.91	3.3545
70.64	21.47	2.8223	79.74	26.52	3.0908	89.63	32.02	3.3594
70.80	21.56	2.8271	79.91	26.62	3.0957	89.82	32.12	3.3643
70.96	21.65	2.8320	80.08	26.71	3.1006	90.01	32.23	3.3691
71.12	21.74	2.8369	80.26	26.81	3.1055	90.20	32.34	3.3740
71.28	21.82	2.8418	80.43	26.91	3.1104	90.39	32.44	3.3789
71.44	21.91	2.8467	80.60	27.00	3.1152	90.59	32.55	3.3838
71.61	22.01	2.8516	80.77	27.10	3.1201	90.78	32.66	3.3887
71.77	22.10	2.8564	80.95	27.20	3.1250	90.97	32.76	3.3936
71.93	22.19	2.8613	81.12	27.29	3.1299	91.16	32.87	3.3984
72.09	22.27	2.8662	81.29	27.39	3.1348	91.35	32.97	3.4033
72.25	22.36	2.8711	81.47	27.49	3.1396	91.54	33.08	3.4082
72.41	22.45	2.8760	81.64	27.58	3.1445	91.74	33.19	3.4131
72.57	22.54	2.8809	81.81	27.67	3.1494	91.93	33.30	3.4180
72.73	22.63	2.8857	81.99	27.77	3.1543	92.13	33.41	3.4229
72.89	22.72	2.8906	82.16	27.87	3.1592	92.32	33.51	3.4277
73.05	22.81	2.8955	82.33	27.96	3.1641	92.52	33.62	3.4326
73.22	22.90	2.9004	82.51	28.06	3.1689	92.72	33.74	3.4375
73.38	22.99	2.9053	82.69	28.16	3.1738	92.91	33.84	3.4424
73.54	23.08	2.9102	82.86	28.26	3.1787	93.11	33.95	3.4473

FIG. 60 – RETURN AND LEAVING CONDENSING WATER (CONT'D.)

Temp (°F)	Temp (°C)	Vin	Temp (°F)	Temp (°C)	Vin
93.31	34.06	3.4521	105.04	40.58	3.7207
93.51	34.17	3.4570	105.27	40.71	3.7256
93.70	34.28	3.4619	105.50	40.84	3.7305
93.90	34.39	3.4668	105.73	40.96	3.7354
94.10	34.50	3.4717	105.96	41.09	3.7402
94.30	34.61	3.4766	106.20	41.23	3.7451
94.50	34.73	3.4814	106.44	41.36	3.7500
94.70	34.84	3.4863	106.67	41.49	3.7549
94.90	34.95	3.4912	106.91	41.62	3.7598
95.11	35.06	3.4961	107.14	41.75	3.7646
95.31	35.18	3.5010	107.38	41.88	3.7695
95.52	35.29	3.5059	107.62	42.01	3.7744
95.72	35.40	3.5107	107.86	42.15	3.7793
95.93	35.52	3.5156	108.11	42.29	3.7842
96.13	35.63	3.5205	108.35	42.42	3.7891
96.34	35.75	3.5254	108.59	42.55	3.7939
96.54	35.86	3.5303	108.84	42.69	3.7988
96.75	35.98	3.5352	109.08	42.83	3.8037
96.96	36.09	3.5400	109.32	42.96	3.8086
97.17	36.21	3.5449	109.57	43.10	3.8135
97.38	36.33	3.5498	109.82	43.24	3.8184
97.59	36.44	3.5547	110.06	43.37	3.8232
97.80	36.56	3.5596	110.31	43.51	3.8281
98.01	36.68	3.5645	110.56	43.65	3.8330
98.22	36.79	3.5693	110.81	43.79	3.8379
98.43	36.91	3.5742	111.05	43.92	3.8328
98.64	37.03	3.5791	111.31	44.06	3.8477
98.86	37.15	3.5840	111.36	44.09	3.8525
99.07	37.26	3.5889	111.82	44.35	3.8574
99.29	37.39	3.5938	112.08	44.49	3.8623
99.50	37.50	3.5986	112.34	44.64	3.8672
99.71	37.62	3.6035	112.59	44.78	3.8721
99.93	37.74	3.6084	112.85	44.92	3.8770
100.14	37.86	3.6133	113.11	45.06	3.8818
100.36	37.98	3.6182	113.37	45.21	3.8867
100.58	38.10	3.6230	113.63	45.35	3.8916
100.79	38.22	3.6279	113.88	45.49	3.8965
101.01	38.34	3.6328	114.14	45.64	3.9014
101.23	38.46	3.6377			
101.45	38.59	3.6426			
101.67	38.71	3.6475			
101.89	38.83	3.6523			
102.11	38.95	3.6572			
102.33	39.08	3.6621			
102.55	39.20	3.6670			
102.78	39.33	3.6719			
103.00	39.45	3.6768			
103.22	39.57	3.6816			
103.45	39.70	3.6865			
103.67	39.82	3.6914			
103.89	39.94	3.6963			
104.12	40.07	3.7012			
104.35	40.20	3.7061			
104.58	40.33	3.7109			
104.81	40.45	3.7158			

FIG. 61 – OIL AND DISCHARGE TEMPERATURE

Temp (°F)	Temp (°C)	Vin	Temp (°F)	Temp (°C)	Vin	Temp (°F)	Temp (°C)	Vin
31.99	-0.01	0.2637	58.43	14.68	0.5322	75.98	24.44	0.8008
32.63	0.35	0.2686	58.81	14.90	0.5371	76.25	24.59	0.8057
33.27	0.71	0.2734	59.18	15.10	0.5420	76.53	24.74	0.8105
33.90	1.06	0.2783	59.54	15.30	0.5469	76.81	24.90	0.8154
34.51	1.39	0.2832	59.90	15.50	0.5518	77.09	25.05	0.8203
35.12	1.73	0.2881	60.26	15.70	0.5566	77.36	25.20	0.8252
35.73	2.07	0.2930	60.63	15.91	0.5615	77.63	25.35	0.8301
36.32	2.40	0.2979	60.98	16.10	0.5664	77.90	25.50	0.8350
36.91	2.73	0.3027	61.33	16.30	0.5713	78.17	25.65	0.8398
37.49	3.05	0.3076	61.69	16.50	0.5762	78.44	25.80	0.8447
38.05	3.36	0.3125	62.04	16.69	0.5811	78.71	25.95	0.8496
38.61	3.67	0.3174	62.39	16.88	0.5859	78.98	26.10	0.8545
39.18	3.99	0.3223	62.73	17.07	0.5908	79.24	26.25	0.8594
39.72	4.29	0.3271	63.07	17.26	0.5957	79.50	26.39	0.8643
40.26	4.59	0.3320	63.41	17.45	0.6006	79.77	26.54	0.8691
40.80	4.89	0.3369	63.75	17.64	0.6055	80.03	26.69	0.8740
41.33	5.18	0.3418	64.09	17.83	0.6104	80.30	26.84	0.8789
41.85	5.47	0.3467	64.43	18.02	0.6152	80.56	26.98	0.8838
42.37	5.76	0.3516	64.76	18.20	0.6201	80.82	27.12	0.8887
42.89	6.05	0.3564	65.09	18.38	0.6250	81.08	27.27	0.8936
43.39	6.33	0.3613	65.42	18.57	0.6299	81.33	27.41	0.8984
43.89	6.61	0.3662	65.75	18.75	0.6348	81.59	27.55	0.9033
44.39	6.88	0.3711	66.08	18.93	0.6396	81.85	27.70	0.9082
44.88	7.16	0.3760	66.40	19.11	0.6445	82.11	27.84	0.9131
45.36	7.42	0.3809	66.72	19.29	0.6494	82.37	27.99	0.9180
45.84	7.69	0.3857	67.04	19.47	0.6543	82.62	28.12	0.9229
46.32	7.96	0.3906	67.36	19.65	0.6592	82.87	28.26	0.9277
46.79	8.22	0.3955	67.68	19.82	0.6641	83.12	28.40	0.9326
47.25	8.47	0.4004	68.00	20.00	0.6689	83.37	28.54	0.9375
47.72	8.73	0.4053	68.31	20.17	0.6738	83.62	28.68	0.9424
48.18	8.99	0.4102	68.62	20.35	0.6787	83.88	28.82	0.9473
48.63	9.24	0.4150	68.93	20.52	0.6836	84.13	28.96	0.9521
49.07	9.48	0.4199	69.24	20.69	0.6885	84.38	29.10	0.9570
49.52	9.73	0.4248	69.55	20.86	0.6934	84.62	29.24	0.9619
49.97	9.98	0.4297	69.86	21.04	0.6982	84.87	29.37	0.9668
50.40	10.22	0.4346	70.17	21.21	0.7031	85.11	29.51	0.9717
50.83	10.46	0.4395	70.47	21.37	0.7080	85.36	29.65	0.9766
51.26	10.70	0.4443	70.77	21.54	0.7129	85.61	29.79	0.9814
51.69	10.94	0.4492	71.07	21.71	0.7178	85.85	29.92	0.9863
52.11	11.17	0.4541	71.37	21.87	0.7227	86.10	30.06	0.9912
52.53	11.41	0.4590	71.67	22.04	0.7275	86.34	30.19	0.9961
52.94	11.63	0.4639	71.96	22.20	0.7324	86.58	30.32	1.0010
53.36	11.87	0.4688	72.26	22.37	0.7373	86.82	30.46	1.0059
53.77	12.10	0.4736	72.55	22.53	0.7422	87.06	30.59	1.0107
54.17	12.32	0.4785	72.84	22.69	0.7471	87.30	30.72	1.0156
54.57	12.54	0.4834	73.14	22.86	0.7520	87.54	30.86	1.0205
54.97	12.76	0.4883	73.43	23.02	0.7568	87.78	30.99	1.0254
55.37	12.98	0.4932	73.72	23.18	0.7617	88.02	31.12	1.0303
55.76	13.20	0.4980	74.00	23.34	0.7666	88.25	31.25	1.0352
56.15	13.42	0.5029	74.29	23.50	0.7715	88.49	31.39	1.0400
56.54	13.63	0.5078	74.57	23.65	0.7764	88.72	31.51	1.0449
56.92	13.85	0.5127	74.86	23.81	0.7813	88.96	31.65	1.0498
57.31	14.06	0.5176	75.14	23.97	0.7861	89.20	31.78	1.0547
57.68	14.27	0.5225	75.42	24.12	0.7910	89.43	31.91	1.0596
58.06	14.48	0.5273	75.70	24.28	0.7959	89.67	32.04	1.0645

FIG. 61 – OIL AND DISCHARGE TEMPERATURE (CONT'D.)

Temp (°F)	Temp (°C)	Vin	Temp (°F)	Temp (°C)	Vin	Temp (°F)	Temp (°C)	Vin
89.90	32.17	1.0693	101.92	38.85	1.3379	112.86	44.93	1.6064
90.13	32.30	1.0742	102.13	38.96	1.3428	113.06	45.04	1.6113
90.36	32.42	1.0791	102.33	39.08	1.3477	113.25	45.14	1.6162
90.59	32.55	1.0840	102.54	39.19	1.3525	113.44	45.25	1.6211
90.82	32.68	1.0889	102.74	39.30	1.3574	113.63	45.35	1.6260
91.05	32.81	1.0938	102.95	39.42	1.3623	113.82	45.46	1.6309
91.28	32.94	1.0986	103.15	39.53	1.3672	114.01	45.56	1.6357
91.51	33.06	1.1035	103.36	39.65	1.3721	114.20	45.67	1.6406
91.74	33.19	1.1084	103.56	39.76	1.3770	114.40	45.78	1.6455
91.96	33.31	1.1133	103.77	39.88	1.3818	114.59	45.89	1.6504
92.19	33.44	1.1182	103.97	39.99	1.3867	114.78	45.99	1.6553
92.42	33.57	1.1230	104.18	40.10	1.3916	114.97	46.10	1.6602
92.64	33.69	1.1279	104.38	40.21	1.3965	115.16	46.20	1.6650
92.87	33.82	1.1328	104.58	40.33	1.4014	115.35	46.31	1.6699
93.10	33.95	1.1377	104.78	40.44	1.4063	115.54	46.41	1.6748
93.32	34.07	1.1426	104.99	40.55	1.4111	115.73	46.52	1.6797
93.54	34.19	1.1475	105.19	40.66	1.4160	115.92	46.63	1.6846
93.77	34.32	1.1523	105.39	40.78	1.4209	116.11	46.73	1.6895
93.99	34.44	1.1572	105.59	40.89	1.4258	116.30	46.84	1.6943
94.21	34.56	1.1621	105.80	41.00	1.4307	116.49	46.94	1.6992
94.43	34.69	1.1670	105.99	41.11	1.4355	116.67	47.04	1.7041
94.65	34.81	1.1719	106.19	41.22	1.4404	116.86	47.15	1.7090
94.88	34.94	1.1768	106.39	41.33	1.4453	117.05	47.25	1.7139
95.10	35.06	1.1816	106.59	41.44	1.4502	117.24	47.36	1.7188
95.32	35.18	1.1865	106.79	41.55	1.4551	117.43	47.46	1.7236
95.53	35.30	1.1914	106.99	41.66	1.4600	117.62	47.57	1.7285
95.75	35.42	1.1963	107.19	41.78	1.4648	117.80	47.67	1.7334
95.97	35.54	1.2012	107.39	41.89	1.4697	117.99	47.78	1.7383
96.19	35.66	1.2061	107.59	42.00	1.4746	118.18	47.88	1.7432
96.41	35.79	1.2109	107.79	42.11	1.4795	118.37	47.99	1.7480
96.63	35.91	1.2158	107.99	42.22	1.4844	118.56	48.09	1.7529
96.84	36.03	1.2207	108.18	42.33	1.4893	118.74	48.19	1.7578
97.06	36.15	1.2256	108.38	42.44	1.4941	118.93	48.30	1.7627
97.27	36.26	1.2305	108.58	42.55	1.4990	119.12	48.40	1.7676
97.49	36.39	1.2354	108.78	42.66	1.5039	119.31	48.51	1.7725
97.70	36.50	1.2402	108.97	42.76	1.5088	119.49	48.61	1.7773
97.92	36.63	1.2451	109.17	42.88	1.5137	119.68	48.72	1.7822
98.13	36.74	1.2500	109.37	42.99	1.5186	119.87	48.82	1.7871
98.35	36.86	1.2549	109.56	43.09	1.5234	120.05	48.92	1.7920
98.56	36.98	1.2598	109.76	43.20	1.5283	120.24	49.03	1.7969
98.77	37.10	1.2646	109.95	43.31	1.5332	120.43	49.13	1.8018
98.98	37.21	1.2695	110.15	43.42	1.5381	120.61	49.23	1.8066
99.20	37.34	1.2744	110.34	43.53	1.5430	120.80	49.34	1.8115
99.41	37.45	1.2793	110.54	43.64	1.5479	120.98	49.44	1.8164
99.62	37.57	1.2842	110.73	43.74	1.5527	121.17	49.54	1.8213
99.83	37.69	1.2891	110.93	43.85	1.5576	121.35	49.64	1.8262
100.04	37.80	1.2939	111.12	43.96	1.5625	121.54	49.75	1.8311
100.25	37.92	1.2988	111.32	44.07	1.5674	121.72	49.85	1.8359
100.46	38.04	1.3037	111.51	44.18	1.5723	121.91	49.95	1.8408
100.67	38.15	1.3086	111.70	44.28	1.5771	122.10	50.06	1.8457
100.88	38.27	1.3135	111.90	44.39	1.5820	122.28	50.16	1.8506
101.09	38.39	1.3184	112.09	44.50	1.5869	122.47	50.27	1.8555
101.29	38.50	1.3232	112.28	44.60	1.5918	122.65	50.37	1.8604
101.50	38.61	1.3281	112.48	44.71	1.5967	122.84	50.47	1.8652
101.71	38.73	1.3330	112.67	44.82	1.6016	123.02	50.57	1.8701

FIG. 61 – OIL AND DISCHARGE TEMPERATURE (CONT'D.)

Temp (°F)	Temp (°C)	Vin	Temp (°F)	Temp (°C)	Vin	Temp (°F)	Temp (°C)	Vin
123.21	50.68	1.8750	133.27	56.27	2.1436	143.32	61.85	2.4121
123.39	50.78	1.8799	133.46	56.37	2.1484	143.51	61.95	2.4170
123.58	50.88	1.8848	133.64	56.47	2.1533	143.69	62.05	2.4219
123.76	50.98	1.8896	133.82	56.57	2.1582	143.87	62.15	2.4268
123.94	51.08	1.8945	134.00	56.67	2.1631	144.06	62.26	2.4316
124.13	51.19	1.8994	134.18	56.77	2.1680	144.24	62.36	2.4365
124.31	51.29	1.9043	134.37	56.88	2.1729	144.43	62.47	2.4414
124.50	51.39	1.9092	134.55	56.98	2.1777	144.61	62.57	2.4463
124.68	51.49	1.9141	134.73	57.08	2.1826	144.80	62.67	2.4512
124.86	51.59	1.9189	134.91	57.18	2.1875	144.98	62.77	2.4561
125.05	51.70	1.9238	135.09	57.28	2.1924	145.17	62.88	2.4609
125.23	51.80	1.9287	135.28	57.38	2.1973	145.35	62.98	2.4658
125.42	51.90	1.9336	135.46	57.48	2.2021	145.54	63.08	2.4707
125.60	52.00	1.9385	135.64	57.58	2.2070	145.72	63.18	2.4756
125.78	52.10	1.9434	135.82	57.68	2.2119	145.91	63.29	2.4805
125.97	52.21	1.9482	136.01	57.79	2.2168	146.09	63.39	2.4854
126.15	52.31	1.9531	136.19	57.89	2.2217	146.28	63.49	2.4902
126.33	52.41	1.9580	136.37	57.99	2.2266	146.46	63.59	2.4951
126.52	52.52	1.9629	136.55	58.09	2.2314	146.65	63.70	2.5000
126.70	52.62	1.9678	136.73	58.19	2.2363	146.84	63.81	2.5049
126.88	52.72	1.9727	136.92	58.29	2.2412	147.02	63.91	2.5098
127.07	52.82	1.9775	137.10	58.39	2.2461	147.21	64.01	2.5146
127.25	52.92	1.9824	137.28	58.49	2.2510	147.39	64.11	2.5195
127.43	53.02	1.9873	137.46	58.59	2.2559	147.58	64.22	2.5244
127.62	53.13	1.9922	137.65	58.70	2.2607	147.77	64.32	2.5293
127.80	53.23	1.9971	137.83	58.80	2.2656	147.95	64.42	2.5342
127.98	53.33	2.0020	138.01	58.90	2.2705	148.14	64.53	2.5391
128.17	53.43	2.0068	138.19	59.00	2.2754	148.32	64.63	2.5439
128.35	53.53	2.0117	138.37	59.10	2.2803	148.51	64.73	2.5488
128.53	53.63	2.0166	138.56	59.20	2.2852	148.70	64.84	2.5537
128.71	53.73	2.0215	138.74	59.30	2.2900	148.88	64.94	2.5586
128.90	53.84	2.0264	138.92	59.40	2.2949	149.07	65.04	2.5635
129.08	53.94	2.0313	139.11	59.51	2.2998	149.26	65.15	2.5684
129.26	54.04	2.0361	139.29	59.61	2.3047	149.45	65.26	2.5732
129.44	54.14	2.0410	139.47	59.71	2.3096	149.63	65.36	2.5781
129.63	54.24	2.0459	139.65	59.81	2.3145	149.82	65.46	2.5830
129.81	54.34	2.0508	139.84	59.92	2.3193	150.01	65.57	2.5879
129.99	54.44	2.0557	140.02	60.02	2.3242	150.20	65.67	2.5928
130.17	54.54	2.0605	140.20	60.12	2.3291	150.38	65.77	2.5977
130.36	54.65	2.0654	140.39	60.22	2.3340	150.57	65.88	2.6025
130.54	54.75	2.0703	140.57	60.32	2.3389	150.76	65.98	2.6074
130.72	54.85	2.0752	140.75	60.42	2.3438	150.95	66.09	2.6123
130.90	54.95	2.0801	140.94	60.53	2.3486	151.14	66.19	2.6172
131.09	55.05	2.0850	141.12	60.63	2.3535	151.33	66.30	2.6221
131.27	55.15	2.0898	141.30	60.73	2.3584	151.51	66.40	2.6270
131.45	55.25	2.0947	141.49	60.83	2.3633	151.70	66.51	2.6318
131.63	55.35	2.0996	141.67	60.93	2.3682	151.89	66.61	2.6367
131.82	55.46	2.1045	141.85	61.03	2.3730	152.08	66.72	2.6416
132.00	55.56	2.1094	142.04	61.14	2.3779	152.27	66.82	2.6465
132.18	55.66	2.1143	142.22	61.24	2.3828	152.46	66.93	2.6514
132.36	55.76	2.1191	142.40	61.34	2.3877	152.65	67.03	2.6563
132.54	55.86	2.1240	142.59	61.44	2.3926	152.84	67.14	2.6611
132.73	55.97	2.1289	142.77	61.54	2.3975	153.03	67.24	2.6660
132.91	56.07	2.1338	142.95	61.64	2.4023	153.22	67.35	2.6709
133.09	56.17	2.1387	143.14	61.75	2.4072	153.41	67.46	2.6758

FIG. 61 – OIL AND DISCHARGE TEMPERATURE (CONT'D.)

Temp (°F)	Temp (°C)	Vin	Temp (°F)	Temp (°C)	Vin	Temp (°F)	Temp (°C)	Vin
153.60	67.56	2.6807	164.36	73.54	2.9492	175.92	79.96	3.2178
153.79	67.67	2.6855	164.56	73.65	2.9541	176.14	80.08	3.2227
153.98	67.77	2.6904	164.76	73.76	2.9590	176.36	80.21	3.2275
154.17	67.88	2.6953	164.96	73.87	2.9639	176.58	80.33	3.2324
154.36	67.98	2.7002	165.17	73.99	2.9688	176.80	80.45	3.2373
154.55	68.09	2.7051	165.37	74.10	2.9736	177.02	80.57	3.2422
154.74	68.19	2.7100	165.57	74.21	2.9785	177.25	80.70	3.2471
154.94	68.31	2.7148	165.78	74.33	2.9834	177.47	80.82	3.2520
155.13	68.41	2.7197	165.98	74.44	2.9883	177.69	80.95	3.2568
155.32	68.52	2.7246	166.19	74.56	2.9932	177.91	81.07	3.2617
155.51	68.62	2.7295	166.39	74.67	2.9980	178.14	81.20	3.2666
155.70	68.73	2.7344	166.60	74.78	3.0029	178.36	81.32	3.2715
155.90	68.84	2.7393	166.80	74.89	3.0078	178.59	81.45	3.2764
156.09	68.94	2.7441	167.00	75.01	3.0127	178.81	81.57	3.2813
156.28	69.05	2.7490	167.21	75.12	3.0176	179.04	81.70	3.2861
156.47	69.16	2.7539	167.42	75.24	3.0225	179.26	81.82	3.2910
156.67	69.27	2.7588	167.62	75.35	3.0273	179.49	81.95	3.2959
156.86	69.37	2.7637	167.83	75.47	3.0322	179.72	82.07	3.3008
157.05	69.48	2.7686	168.04	75.58	3.0371	179.94	82.20	3.3057
157.25	69.59	2.7734	168.24	75.69	3.0420	180.17	82.32	3.3105
157.44	69.69	2.7783	168.45	75.81	3.0469	180.40	82.45	3.3154
157.64	69.81	2.7832	168.66	75.93	3.0518	180.63	82.58	3.3203
157.83	69.91	2.7881	168.87	76.04	3.0566	180.86	82.71	3.3252
158.02	70.02	2.7930	169.07	76.16	3.0615	181.09	82.83	3.3301
158.22	70.13	2.7979	169.28	76.27	3.0664	181.32	82.96	3.3350
158.41	70.23	2.8027	169.49	76.39	3.0713	181.55	83.09	3.3398
158.61	70.34	2.8076	169.70	76.51	3.0762	181.78	83.22	3.3447
158.80	70.45	2.8125	169.91	76.62	3.0811	182.01	83.35	3.3496
159.00	70.56	2.8174	170.12	76.74	3.0859	182.24	83.47	3.3545
159.19	70.67	2.8223	170.33	76.86	3.0908	182.48	83.61	3.3594
159.39	70.78	2.8271	170.54	76.97	3.0957	182.71	83.73	3.3643
159.59	70.89	2.8320	170.75	77.09	3.1006	182.94	83.86	3.3691
159.78	70.99	2.8369	170.96	77.21	3.1055	183.17	83.99	3.3740
159.98	71.11	2.8418	171.18	77.33	3.1104	183.41	84.12	3.3789
160.18	71.22	2.8467	171.39	77.45	3.1152	183.65	84.26	3.3838
160.37	71.32	2.8516	171.60	77.56	3.1201	183.88	84.38	3.3887
160.57	71.43	2.8564	171.81	77.68	3.1250	184.12	84.52	3.3936
160.77	71.54	2.8613	172.02	77.80	3.1299	184.36	84.65	3.3984
160.97	71.66	2.8662	172.24	77.92	3.1348	184.59	84.78	3.4033
161.16	71.76	2.8711	172.45	78.03	3.1396	184.83	84.91	3.4082
161.36	71.87	2.8760	172.66	78.15	3.1445	185.07	85.05	3.4131
161.56	71.98	2.8809	172.88	78.27	3.1494	185.31	85.18	3.4180
161.76	72.09	2.8857	173.10	78.40	3.1543	185.55	85.31	3.4229
161.96	72.21	2.8906	173.31	78.51	3.1592	185.79	85.45	3.4277
162.15	72.31	2.8955	173.53	78.63	3.1641	186.03	85.58	3.4326
162.35	72.42	2.9004	173.74	78.75	3.1689	186.27	85.71	3.4375
162.55	72.53	2.9053	173.96	78.87	3.1738	186.51	85.85	3.4424
162.75	72.64	2.9102	174.17	78.99	3.1787	186.75	85.98	3.4473
162.95	72.76	2.9150	174.39	79.11	3.1836	186.99	86.11	3.4521
163.15	72.87	2.9199	174.61	79.23	3.1885	187.24	86.25	3.4570
163.35	72.98	2.9248	174.83	79.36	3.1934	187.48	86.38	3.4619
163.55	73.09	2.9297	175.04	79.47	3.1982	187.73	86.52	3.4668
163.75	73.20	2.9346	175.26	79.60	3.2031	187.97	86.66	3.4717
163.96	73.32	2.9395	175.48	79.72	3.2080	188.22	86.80	3.4766
164.16	73.43	2.9443	175.70	79.84	3.2129	188.46	86.93	3.4814

FIG. 61 – OIL AND DISCHARGE TEMPERATURE (CONT'D.)

Temp (°F)	Temp (°C)	Vin	Temp (°F)	Temp (°C)	Vin
188.71	87.07	3.4863	203.40	95.23	3.7549
188.96	87.21	3.4912	203.69	95.39	3.7598
189.21	87.35	3.4961	203.99	95.56	3.7646
189.46	87.48	3.5010	204.28	95.72	3.7695
189.71	87.62	3.5059	204.57	95.88	3.7744
189.96	87.76	3.5107	204.86	96.04	3.7793
190.21	87.90	3.5156	205.16	96.21	3.7842
190.46	88.04	3.5205	205.46	96.37	3.7891
190.71	88.18	3.5254	205.76	96.54	3.7939
190.96	88.32	3.5303	206.05	96.70	3.7988
191.22	88.46	3.5352	206.35	96.87	3.8037
191.47	88.60	3.5400	206.65	97.04	3.8086
191.73	88.75	3.5449	206.96	97.21	3.8135
191.98	88.88	3.5498	207.26	97.37	3.8184
192.23	89.02	3.5547	207.57	97.55	3.8232
192.49	89.17	3.5596	207.87	97.71	3.8281
192.75	89.31	3.5645	208.17	97.88	3.8330
193.01	89.46	3.5693	208.48	98.05	3.8379
193.27	89.60	3.5742	208.79	98.22	3.8428
193.53	89.75	3.5791	209.10	98.40	3.8477
193.79	89.89	3.5840	209.42	98.57	3.8525
194.05	90.03	3.5889	209.73	98.75	3.8574
194.31	90.18	3.5938	210.04	98.92	3.8623
194.57	90.32	3.5986	210.35	99.09	3.8672
194.84	90.47	3.6035	210.67	99.27	3.8721
195.10	90.62	3.6084	210.99	99.45	3.8770
195.37	90.77	3.6133	211.31	99.62	3.8818
195.63	90.91	3.6182	211.62	99.80	3.8867
195.90	91.06	3.6230	211.94	99.97	3.8916
196.16	91.21	3.6279	212.27	100.16	3.8965
196.43	91.36	3.6328	212.59	100.34	3.9014
196.70	91.51	3.6377	212.92	100.52	3.9063
196.97	91.66	3.6426	213.24	100.70	3.9111
197.24	91.81	3.6475	213.57	100.88	3.9160
197.51	91.96	3.6523	213.90	101.06	3.9209
197.78	92.11	3.6572	214.23	101.25	3.9258
198.06	92.26	3.6621	214.56	101.43	3.9307
198.33	92.41	3.6670	214.89	101.61	3.9355
198.61	92.57	3.6719	215.23	101.80	3.9404
198.88	92.72	3.6768	215.56	101.99	3.9453
199.15	92.87	3.6816	215.90	102.17	3.9502
199.43	93.02	3.6865	216.24	102.36	3.9551
199.71	93.18	3.6914	216.58	102.55	3.9600
199.99	93.34	3.6963	216.92	102.74	3.9648
200.27	93.49	3.7012	217.26	102.93	3.9697
200.55	93.65	3.7061	217.60	103.12	3.9746
200.83	93.80	3.7109	217.95	103.31	3.9795
201.11	93.96	3.7158	218.30	103.51	3.9844
201.39	94.11	3.7207	218.65	103.70	3.9893
201.68	94.27	3.7256	219.00	103.90	3.9941
201.97	94.44	3.7305	219.35	104.09	3.9990
202.25	94.59	3.7354	219.70	104.29	4.0039
202.54	94.75	3.7402	220.06	104.49	4.0088
202.82	94.91	3.7451			
203.11	95.07	3.7500			

FIG. 62 – DROP LEG REFRIGERANT SENSOR

Temp (°F)	Temp (°C)	Vin
0.01	-17.77	0.753
3.72	-15.71	0.831
7.21	-13.77	0.909
10.51	-11.94	0.987
13.65	-10.20	1.066
16.65	-8.53	1.144
19.56	-6.91	1.222
22.36	-5.36	1.300
25.09	-3.84	1.378
27.74	-2.37	1.456
30.34	-0.92	1.534
32.89	0.49	1.613
35.40	1.89	1.691
37.87	3.26	1.769
40.31	4.62	1.847
42.73	5.96	1.925
45.14	7.30	2.003
47.53	8.63	2.081
49.92	9.96	2.160
52.31	11.28	2.238
54.70	12.61	2.316
57.10	13.95	2.394
59.52	15.29	2.472
61.95	16.64	2.550
64.40	18.00	2.628
66.89	19.38	2.707
69.40	20.78	2.785
71.97	22.21	2.863
74.57	23.65	2.941
77.23	25.13	3.019
79.96	26.65	3.097
82.73	28.19	3.175
85.60	29.78	3.254
88.56	31.42	3.332
91.59	33.11	3.410
94.75	34.86	3.488
98.06	36.70	3.566
101.50	38.61	3.644
105.10	40.61	3.722
108.90	42.73	3.801
112.92	44.96	3.879
117.17	47.32	3.957
121.76	49.87	4.035

FIG. 63 – EVAPORATOR REFRIGERANT SENSOR

Temp (°F)	Temp (°C)	Vin
0.04	-17.76	1.135
2.79	-16.23	1.214
5.44	-14.76	1.292
8.02	-13.32	1.370
10.53	-11.93	1.448
12.98	-10.57	1.526
15.39	-9.23	1.604
17.75	-7.92	1.683
20.08	-6.62	1.761
22.38	-5.34	1.839
24.66	-4.08	1.917
26.92	-2.82	1.995
29.17	-1.57	2.073
31.41	-0.33	2.151
33.66	0.92	2.230
35.90	2.17	2.308
38.15	3.42	2.386
40.41	4.67	2.464
42.69	5.94	2.542
44.99	7.72	2.620
47.31	8.51	2.698
49.67	9.82	2.777
52.06	11.15	2.855
54.49	12.50	2.933
56.96	13.87	3.011
59.50	15.28	3.089
62.10	16.72	3.167
64.77	18.21	3.245
67.51	19.73	3.324
70.35	21.31	3.402
73.29	22.94	3.480
76.36	24.65	3.558
79.55	26.42	3.636
82.89	28.27	3.714
86.41	30.23	3.792
90.12	32.29	3.871
94.07	34.49	3.949
98.31	36.84	4.027
102.87	39.38	4.105
107.81	42.12	4.183
113.26	45.15	4.261
119.30	48.50	4.339
126.10	52.28	4.418

FIG. 63A – LEAVING & RETURN HEATING CONDENSER WATER TEMPERATURE SENSOR

Temp (°F)	Temp (°C)	Vin
32.63	0.35	1.713
37.47	3.03	1.870
42.23	5.68	2.026
46.96	9.97	2.182
51.68	10.93	2.338
56.44	13.57	2.495
61.28	16.26	2.651
66.23	19.01	2.807
71.36	21.86	2.963
76.70	24.61	3.120
82.32	27.955	3.276
88.31	31.28	3.432
94.74	34.85	3.588
101.8	38.77	3.745
109.6	43.11	3.901
118.5	48.05	4.057
128.9	53.83	4.213
141.7	60.94	4.370
158.2	70.11	4.526

SECTION 19 REMOTE SETPOINTS

(See FIGS. 12, 14 & 17)

There are three different Remote operating Modes that can be selected at the Keypad: **Analog** Remote mode, **Digital** Remote Mode or **ISN** Remote Mode.

The OptiView Control Center can receive a remote Current Limit and/or a Remote Leaving Chilled Liquid Temperature Setpoint via the following:

Analog Remote Mode

- 0-10VDC Analog Input
- 2-10VDC Analog Input
- 0-20mA Analog Input
- 4-20mA Analog Input

When equipped with software version C.OPT.01.18.307 (or later), software filtering is applied to these inputs. This stabilizes the remote setpoint values under electrical noise conditions and when the inputs are unstable.

Digital Remote Mode

- Pulse width Modulation (PWM) Input

ISN Remote Mode

- RS-232 Serial Port via MicroGateway

The Analog inputs are connected to the Microboard J22 as shown in FIG. 12 and described below. Microboard Program Jumpers JP23 and JP24 must be positioned appropriately to receive either a 0-10VDC, 2-10VDC, 0-20mA or a 4-20mA signal. Refer to Table 1 “Microboard Program Jumpers” and explanation below for required configurations.

The PWM inputs are in the form of a 1 to 11 second Relay contact closure that applies 115VAC to the I/O Board TB4-19 (Leaving Chilled Liquid Temp) and TB4-20 (Remote Current Limit) for 1 to 11 seconds. Refer to FIG. 14. The source of 115VAC is I/O Board TB4-1. The PWM input must be received at a frequency of at least once every 30 minutes. If not received within this time interval, the Program assumes the remote device is defective and defaults the Current Limit Setpoint to 100% and the Leaving Chilled Liquid Temperature Setpoint to the locally programmed Local **BASE** value.

The Microboard COM 4B RS-232 Serial Port (J2) receives the Setpoints in serial data form from the MicroGateway located inside the OptiView Control Center enclosure. The MicroGateway receives Setpoints from remote external devices and transfers them to the Microboard.

CURRENT LIMIT

REMOTE CURRENT LIMIT SETPOINT with 0-10VDC, 2-10VDC, 0-20mA, 4-20mA or Pulse Width Modulation Signal –

The Remote Current Limit setpoint can be reset over the range of 100% to 30% Full Load Amps (FLA) by supplying (by others) a 0-10VDC, 2-10VDC, 0-20mA, 4-20mA or 1 to 11 second Pulse Width Modulated (PWM) signal to the OptiView Control Center. The OptiView Control Center must be configured appropriately to accept the desired signal type as follows:

- The appropriate Remote Mode must be selected: **ANALOG** Remote Mode must be selected when using a voltage or current signal input. **DIGITAL** Remote Mode must be selected when using a **PWM** input.
- If **ANALOG** Remote Mode is selected, the **REMOTE ANALOG INPUT RANGE** setpoint must be set to “0-10VDC” or “2-10VDC” as detailed below, regardless of whether the signal is a voltage or current input signal type.
- Microboard Program Jumper JP23 must be positioned appropriately per the input signal type as detailed below. It is recommended that a qualified Service Technician position this jumper.

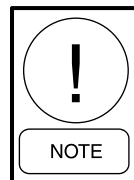

IMPORTANT! - The signal type used for Remote Current Limit setpoint reset and the signal type used for Remote Leaving Chilled Liquid Temperature setpoint reset must be the same. For example, if a 0-10VDC signal is being used for Remote Leaving Chilled Liquid Temperature Reset, then a 0-10VDC signal must be used for Remote Current Limit Reset.

0-10VDC

As shown in FIG. 12, connect input to Microboard J22-1 (signal) and J22-5 (Gnd). The setpoint varies linearly from 100% to 30% FLA as the input varies from 0 to 10VDC. This input will only be accepted when **ANALOG** Remote Mode is selected, the **REMOTE ANALOG INPUT RANGE** setpoint is set for “0-10 Volts” and Microboard Program Jumper JP23 has been removed. Calculate the setpoint for various inputs as follows:

$$\text{Setpoint (\%)} = 100 - (\text{VDC} \times 7)$$

For example, if the input is 5VDC, the setpoint would be set to 65% as follows:

$$\begin{aligned} \text{Setpoint (\%)} &= 100 - (5 \times 7) \\ &= 100 - 35 \\ &= 65\% \end{aligned}$$

2-10VDC

As shown in FIG. 12, connect input to Microboard J22-1 (signal) and J22-5 (Gnd). The setpoint varies linearly from 100% to 30% FLA as the input varies from 2 to 10VDC. This input will only be accepted when **ANALOG** Remote Mode is selected, the **REMOTE ANALOG INPUT RANGE** setpoint is set for “2-10 Volts” and Microboard Program Jumper JP23 has been removed. Calculate the setpoint for various inputs as follows:

$$\text{Setpoint (\%)} = 100 - [(\text{VDC} - 2) \times 8.75]$$

For example, if the input is 5VDC, the setpoint would be set to 74% as follows:

$$\begin{aligned} \text{Setpoint (\%)} &= 100 - [(5 - 2) \times 8.75] \\ &= 100 - [3 \times 8.75] \\ &= 100 - 26.25 \\ &= 74\% \end{aligned}$$

0-20mA

As shown in FIG. 12, connect input to Microboard J22-2 (signal) and J22-5 (Gnd). The setpoint varies linearly from 100% to 30% FLA as the input varies from 0mA to 20mA. This input will only be accepted when **ANALOG** remote mode is selected, the **REMOTE ANALOG INPUT RANGE** setpoint is set for “0-10 Volts” and Microboard Program Jumper JP23 has been placed on pins 1 and 2. Calculate the setpoint for various inputs as follows:

$$\text{Setpoint (\%)} = 100 - (\text{mA} \times 3.5)$$

For example, if the input is 8mA, the setpoint would be set to 72% as follows:

$$\begin{aligned} \text{Setpoint (\%)} &= 100 - (8 \times 3.5) \\ &= 100 - 28 \\ &= 72\% \end{aligned}$$

4-20mA

As shown in FIG. 12, connect input to Microboard J22-2 (signal) and J22-5 (Gnd). The setpoint varies linearly from 100% to 30% FLA as the input varies from 4mA to 20mA. This input will only be accepted when **ANALOG** remote mode is selected, the **REMOTE ANALOG INPUT RANGE** setpoint is set for “2-10 Volts” and Microboard Program Jumper JP23 has been placed on pins 1 and 2. Calculate the setpoint for various inputs as follows:

$$\text{Setpoint (\%)} = 100 - [(\text{mA} - 4) \times 4.375]$$

For example, if the input is 8mA, the setpoint would be set to 83% as follows:

$$\begin{aligned} \text{Setpoint (\%)} &= 100 - [(8 - 4) \times 4.375] \\ &= 100 - (4 \times 4.375) \\ &= 100 - 17.5 \\ &= 82.5 \\ &= 83\% \end{aligned}$$

PWM

The Pulse Width Modulation input is in the form of a 1 to 11 second relay contact closure that applies 115VAC to the I/O Board TB4-20 for 1 to 11 seconds. As shown in FIG. 14, connect dry closure relay contacts between I/O Board TB4-20 (signal) and TB4-1 (115Vac). The setpoint varies linearly from 100% to 30% as the relay contact closure time changes from 1 to 11 seconds. The relay contacts should close for 1 to 11 seconds at least once every 30 minutes to maintain the setpoint to the desired value. If a 1 to 11 second closure is not received within 30 minutes of the last closure, the setpoint is defaulted to 100%. A closure is only accepted at rates not to exceed once every 70 seconds. This input will only be accepted in **DIGITAL** remote mode. Calculate the setpoint for various pulse widths as follows:

$$\text{Setpoint (\%)} = 100 - [(\text{pulse width in seconds} - 1) \times 7]$$

For example, if the relay contacts close for 3 seconds, the setpoint would be set to 86% as follows:

$$\begin{aligned} \text{Setpoint (\%)} &= 100 - [(3 - 1) \times 7] \\ &= 100 - (2 \times 7) \\ &= 100 - 14 \\ &= 86\% \end{aligned}$$

RS-232

As shown in FIG.11, a setpoint can be received in serial data form at Microboard J2 from the GPIC.

LEAVING CHILLED LIQUID TEMPERATURE

REMOTE LEAVING CHILLED LIQUID TEMPERATURE SETPOINT with 0-10VDC, 2-10VDC, 0-20mA, 4-20mA or Pulse Width Modulation Signal

Remote Leaving Chilled Liquid Temperature setpoint reset can be accomplished by supplying (by others) a 0-10VDC, 2-10VDC, 0-20mA, 4-20mA or 1 to 11 second Pulse Width Modulated (PWM) signal to the OptiView Control Center. The **LEAVING CHILLED LIQUID TEMPERATURE** setpoint is programmable over the range of 38°F to 70°F (water applications); 36°F to 70°F (water applications with Smart Freeze protection enabled); or 10°F to 70°F (brine applications). The Remote input signal changes the setpoint by creating an offset above the locally programmed Leaving Chilled Liquid Temperature Base setpoint value. The setpoint can be remotely changed over the range of the value programmed for the **REMOTE RESET TEMPERATURE RANGE** setpoint (10, 20, 30, or 40°F with Software version C.OPT.01.18.307 (or later); 10 or 20°F with earlier software versions). For example, if the Local setpoint is 40°F and the **REMOTE RESET TEMPERATURE RANGE** setpoint is programmed for 10°F, the Leaving Chilled Liquid Temperature setpoint can be remotely reset over the range of 40°F to 50°F. The setpoint received through the COM 4B RS-232 serial port is not an offset that is applied to the locally programmed **BASE** value as described above. Rather, it is an actual Setpoint value. The locally programmed value is not used as a **BASE** in this application.

The OptiView Control Center must be configured appropriately to accept the desired signal type as follows:

- The appropriate Remote Mode must be selected: **ANALOG** Remote Mode must be selected when using a voltage or current signal input. **DIGITAL** Remote Mode must be selected when using a PWM input.

- If **ANALOG** Remote Mode is selected, the **REMOTE ANALOG INPUT RANGE** setpoint must be set to “0-10VDC” or “2-10VDC” as detailed below, regardless of whether the signal is a voltage or current signal type.
- Microboard Program Jumper JP24 must be positioned appropriately per the input signal type as detailed below. It is recommended a qualified Service Technician position this jumper.

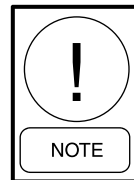

IMPORTANT! - The signal type used for Remote Leaving Chilled Liquid Temperature setpoint reset and the signal type used for Remote Current Limit setpoint reset must be the same. For example, if a 0-10VDC signal is being used for Remote Current Limit setpoint reset, then a 0-10VDC signal must be used for Leaving Chilled Liquid Temperature reset.

0-10VDC

As shown in FIG. 12, connect input to Microboard J22-3 (signal) and J22-5 (Gnd). A 0VDC signal produces a 0°F offset. A 10VDC signal produces the maximum offset above the Local Setpoint value (as allowed by the **REMOTE RESET TEMPERATURE RANGE** setpoint). The setpoint is changed linearly between these extremes as the input varies linearly over the range of 0VDC to 10VDC. This input will only be accepted when **ANALOG** Remote mode is selected, the **REMOTE ANALOG INPUT RANGE** setpoint is set for “0-10VDC” and Microboard Program Jumper JP24 has been removed. Calculate the setpoint for various inputs as follows:

$$\text{Offset (°F)} = \frac{(\text{VDC})(\text{Remote Reset Temp Range})}{10}$$

$$\text{Setpoint (°F)} = \text{Local Setpoint} + \text{Offset}$$

For example, if the input is 5VDC and the Remote Reset Temp Range setpoint is programmed for 10°F and the Local Leaving Chilled Liquid Temperature setpoint is programmed for 40°F, the setpoint would be set to 45°F as follows:

$$\begin{aligned} \text{Offset (°F)} &= \frac{5 \times 10}{10} \\ &= \frac{50}{10} \\ &= 5^\circ\text{F} \end{aligned}$$

$$\begin{aligned}\text{Setpoint} &= 40 + 5 \\ &= 45^{\circ}\text{F}\end{aligned}$$

2-10VDC

As shown in FIG. 12, connect input to Microboard J22-3 (signal) and J2-5 (Gnd). A 2VDC signal produces a 0°F offset. A 10VDC signal produces the maximum allowed offset above the Local Setpoint value (as allowed by the REMOTE RESET TEMPERATURE RANGE setpoint). The setpoint is changed linearly between these extremes as the input varies over the range of 2VDC to 10VDC. This input will only be accepted when **ANALOG** remote mode is selected, the **REMOTE ANALOG INPUT RANGE** setpoint is set for “2-10VDC” and the Microboard Program Jumper JP24 has been removed. Calculate the setpoint for various inputs as follows:

$$\text{Offset } (^{\circ}\text{F}) = \frac{(\text{VDC} - 2)(\text{Remote Reset Temp Range})}{8}$$

$$\text{Setpoint } (^{\circ}\text{F}) = \text{Local Setpoint} + \text{Offset}$$

For example, if the input is 5VDC and the Remote Reset Temp Range setpoint is programmed for 10°F and the Local Leaving Chilled Liquid Temperature setpoint is programmed for 40°F, the setpoint would be set to 43.8°F.

$$\begin{aligned}\text{Offset } (^{\circ}\text{F}) &= \frac{(5 - 2)(10)}{8} \\ &= \frac{(3)(10)}{8} \\ &= \frac{30}{8} \\ &= 3.8^{\circ}\text{F}\end{aligned}$$

$$\begin{aligned}\text{Setpoint } (^{\circ}\text{F}) &= 40 + 3.8 \\ &= 43.8^{\circ}\text{F}\end{aligned}$$

0-20mA

As shown in FIG. 12, connect input to Microboard J22-4 (signal) and J22-5 (Gnd). A 0mA signal produces a 0°F offset. A 20mA signal produces the maximum allowed offset above the Local Setpoint value (as allowed by the REMOTE RESET TEMPERATURE RANGE setpoint). The setpoint is changed linearly between these extremes as the input varies over the range of 0-20mA. This input will only be accepted when **ANALOG** remote mode is selected, the **REMOTE ANALOG INPUT RANGE** setpoint is set for “0-10VDC” and Microboard Program Jumper J24 has been placed on pins 1 and 2. Calculate the setpoint for various inputs as follows:

$$\text{Offset } (^{\circ}\text{F}) = \frac{(\text{mA})(\text{Remote Reset Temp Range})}{20}$$

$$\text{Setpoint } (^{\circ}\text{F}) = \text{Local Setpoint} + \text{Offset}$$

For example, if the input is 8mA, the Remote Reset Temp Range Setpoint is programmed for 10°F and the Local Leaving Chilled Liquid Temperature setpoint is programmed for 40°F, the setpoint would be set to 44°F as follows:

$$\begin{aligned}\text{Offset } (^{\circ}\text{F}) &= \frac{(8)(10)}{20} \\ &= \frac{80}{20} \\ &= 4^{\circ}\text{F}\end{aligned}$$

$$\begin{aligned}\text{Setpoint } (^{\circ}\text{F}) &= 40 + 4 \\ &= 44^{\circ}\text{F}\end{aligned}$$

4-20mA

As shown in FIG. 12, connect input to Microboard J22-4 (signal) and J22-5 (Gnd). A 4mA signal produces a 0°F offset. A 20mA signal produces the maximum allowed offset above the Local Setpoint value (as allowed by the REMOTE RESET TEMPERATURE RANGE setpoint). The setpoint is changed linearly between these extremes as the input varies over the range of 4-20mA. This input will only be accepted when **ANALOG** Remote mode is selected, the **REMOTE ANALOG INPUT RANGE** setpoint is set for “2-10VDC” and Microboard Program Jumper JP24 has been placed on pins 1 and 2. Calculate the setpoint for various inputs as follows:

$$\text{Offset } (^{\circ}\text{F}) = \frac{(\text{mA}-4)(\text{Remote Reset Temp Range})}{16}$$

$$\text{Setpoint } (^{\circ}\text{F}) = \text{Local Setpoint} + \text{Offset}$$

For example, if the input is 8mA, and the Remote Reset Temp Range setpoint is programmed for 10°F and the Local Leaving Chilled Liquid Temperature setpoint is programmed for 40°F, the setpoint would be set to 42.5°F as follows:

$$\begin{aligned}\text{Offset } (^{\circ}\text{F}) &= \frac{(8-4)(10)}{16} \\ &= \frac{(4)(10)}{16}\end{aligned}$$

$$= \frac{40}{16}$$

$$= 2.5^{\circ}\text{F}$$

$$\text{Setpoint } (^{\circ}\text{F}) = 40 + 2.5$$

$$= 42.5$$

PWM

The Pulse Width Modulation input is in the form of a 1 to 11 second relay contact closure that applies 115VAC to the I/O Board TB4-19 for 1 to 11 seconds. As shown in FIG. 14, connect dry closure relay contacts between I/O Board TB4-19 (input) and TB4-1 (115VAC). A contact closure time (pulse width) of 1 second produces a 0°F offset. An 11 second closure produces the maximum allowed offset above the Local Setpoint value (as allowed by the REMOTE RESET TEMPERATURE RANGE setpoint). The relay contacts should close for 1 to 11 seconds at least once every 30 minutes to maintain the setpoint to the desired value. If a 1 to 11 second closure is not received within 30 minutes of the last closure, the setpoint is defaulted to the Local setpoint value. A closure is only accepted at rates not to exceed once every 70 seconds. This input will only be accepted in **DIGITAL** Remote mode. Calculate the setpoint for various pulse widths as follows:

$$\text{Offset } (^{\circ}\text{F}) = \frac{(\text{pulse width in seconds} - 1)(\text{Remote Reset Temp Range})}{10}$$

$$\text{Setpoint } (^{\circ}\text{F}) = \text{Local Setpoint} + \text{Offset}$$

For example, if the relay contacts close for 5 seconds and the Remote Reset Temp Range setpoint is programmed to 10°F and the Local Leaving Chilled Liquid Temperature setpoint is programmed for 40°F, the setpoint would be set to 44°F as follows:

$$\text{Offset } (^{\circ}\text{F}) = \frac{(5 - 1)(10)}{10}$$

$$= \frac{(4)(10)}{10}$$

$$= \frac{40}{10}$$

$$= 4^{\circ}\text{F}$$

$$\text{Setpoint } (^{\circ}\text{F}) = 40 + 4$$

$$= 44^{\circ}\text{F}$$

RS-232

As shown in FIG. 11, a Setpoint can be received in serial data form at the Microboard COM 4B serial port (J2) from the MicroGateway.

SECTION 20 HOT GAS BYPASS

(REFER TO FIG. 64)

With the optional Hot Gas Bypass feature, the Control Center modulates a valve located in the Hot Gas Bypass connection between the condenser and the evaporator to control the flow of gas to the evaporator. The valve is modulated in response to load and surging conditions.

A Hot Gas Bypass Screen, accessed from the COMPRESSOR Screen displays all the applicable parameters and allows a Service Technician to program the applicable setpoints and manually control the Hot Gas valve. If the chiller is equipped with the optional Hot Gas Bypass control, it must be Enabled from the OPERATIONS Screen using a procedure in the “System Calibration Service Setpoints and Reset Procedures” section of this book. If Disabled, the valve is driven to the fully closed position.

The Microboard controls the Hot Gas Valve by sending a positioning command over the COM3 RS-485 serial communications link to the optional I/O Board that is mounted inside the control center. This board converts the command into the appropriate signal to control the valve as explained later in this section. The valve position is displayed on the Hot Gas Bypass Screen as 0% (closed) to 100% (fully open).

A Potentiometer mounted on the Pre-rotation vanes provides PRV position for this feature, as explained later in this section). It is displayed on the Hot Gas Bypass Screen as 0% (closed) to 100% (fully open).

The Evaporator and Condenser pressure transducers provide these pressure values to the Microboard. The Microboard uses these values to calculate the **DELTA P/P** parameter as follows: [(condenser pressure – evaporator pressure) / evaporator pressure]. Although this parameter is not used in the Hot Gas Control, it represents compressor “Head” and is displayed on the Hot Gas Bypass Screen for reference only. These pressures are also used to detect when a surge occurs.

The Hot Gas valve is modulated in response to certain load conditions and surge events as described below under “Operations”. The load conditions are represented by the value “Temperature Differential (Leaving Chilled Liquid Temperature – Setpoint)” on the Hot Gas Screen. The surge events it reacts to are detected by the SURGE PROTECTION feature (refer to Section 22). For reference, surge detect indicators and the total surge count are displayed on the Hot Gas Screen as follows: Each time a surge is detected, the SURGE AVOIDANCE SURGE DETECTED indicator illuminates momentarily (if equipped with a VSD or MV VSD, this feature only detects surges while the drive is running at maximum frequency)(If equipped with software version C.OPT.01.18.307 or earlier, the indicator is labeled SURGE DETECTED and it illuminates whenever a surge detected, regardless of VSD operating frequency.

If equipped with a VSD (in MODBUS protocol configuration) or a MV VSD, the ACC SURGE DETECTED indicator illuminates momentarily when a surge is detected by the ACC function in the Microboard, while the drive is running at less than maximum frequency. Software version C.OPT.01.18.307 or earlier does not have this indicator. The SURGE AVOIDANCE SURGE COUNT (displayed as “Total Surge Count” in software version C.OPT.01.18.307 and earlier) is the total number of surges detected by the Surge Protection feature (if equipped with a VSD or MV VSD, this feature only detects surges while the drive is running at maximum frequency).

SETPOINTS

- **Surge Sensitivity** (0.3 to 1.3; default 0.3) – Determines the surge detection sensitivity. The smaller the number, the greater the sensitivity. Programmable in 0.1 increments. This setpoint is programmed on the Surge Protection Screen and is common to the Surge Protection feature.
- **Hold Period** (30 to 120 minutes; default 30) – This is the period of time after no more surges are detected that the Hot Gas valve closing will begin. It will be driven toward the closed position in increments equal to the Close Percentage setpoint at 10 minute intervals until fully closed. Programmable in 1 minute increments.
- **Close Percentage** (5 to 15%; default 5%) – This is the incremental amount that the Hot Gas valve will be closed at 10 minute intervals after the HOLD PERIOD has elapsed. Refer to HOLD PERIOD above.
- **Minimum Load** (0°F to 4°F; default 0°F) – This sets the Minimum Load override threshold. It is the offset below the Leaving Chilled Liquid Temperature Setpoint at which the Hot Gas Bypass valve will be opened to the position allowed per the MAXIMUM OPEN setpoint (25% to 100%). If “0” is entered for this value, this feature is disabled.
- **Maximum Open** (25% to 100%; default 100%) – This is the maximum allowed position for the Hot Gas valve during a Minimum Load override condition. Allows the user to adjust the quantity of Hot Gas for the local requirements.

OPERATION

While the chiller is shutdown, the Hot Gas valve is driven to the fully closed position. While the chiller is running, the valve is modulated in response to low load, high load or surge conditions. However, manual control can override this operation.

If the Leaving Chilled Liquid Temperature decreases to less than the **Minimum Load** setpoint, the valve is opened to the maximum allowed by the **Maximum Open** setpoint and “MINIMUM LOAD” (“Override” in software version C.OPT.01.18.307 and earlier) is displayed as the Hot Gas Bypass Control mode on the Hot Gas Bypass Screen. For example, if the Minimum Load is set for 4°F and the Maximum Open is set for 80%, the valve will be positioned to 80% open when the Leaving Chilled Liquid Temperature decreases to more than 4°F below the Leaving Chilled Liquid Temperature

setpoint. After this Minimum Load Override is initiated, as the Leaving Chilled Liquid Temperature rises to the Leaving Chilled Liquid Temperature setpoint, the valve is closed by an amount proportional to the difference between the temperature delta and the minimum Load setpoint. In this example, when the Leaving Chilled Liquid Temperature increases to 2°F below the Leaving Chilled Liquid Temperature setpoint, the valve will be positioned to 40% open. The valve is closed accordingly until the temperature delta is 0°F.

If the Pre-Rotation Vanes are more than 95% open and the Leaving Chilled Liquid Temperature is at least 5°F above the Leaving Chilled Liquid Temperature setpoint, the valve is set to one-half of its present position for 10 minutes. After the 10 minutes have elapsed, the valve is driven fully closed.

With software version C.OPT.01.18.307 and earlier, if the chiller is equipped with a Variable Speed Drive (VSD), whenever the VSD is running at < full speed (50/60 Hz), the Hot gas Bypass valve is driven to the fully closed position and “OVERRIDE” is displayed as the Hot Gas Bypass Control Mode.

If none of the above conditions are in effect, the Hot Gas Bypass valve is driven to the fully closed position, until a surge condition is detected. When a surge is detected, the Hot Gas valve is opened a certain percentage every few minutes until the surging stops or the valve is fully opened as follows:

- If Hot Gas valve is fully closed, it is driven to the 50% position. There will be no valve response to surge events for the next 5 minutes.
- If Hot Gas valve position is < 35%, it is driven to the 50% position. There will be no valve response to surge events for the next 3.5 minutes.
- If Hot Gas valve position is > 35% but < 50%, it is driven to the 50% position. There will be no valve response to surge events in the next 2 minutes.
- If Hot Gas valve position is >50%, it is driven open another 10%. There will be no valve response to surge events in the next 2 minutes.

After the chiller has not surged for the period of time programmed as the **HOLD PERIOD** setpoint, the valve is driven toward the closed position at 10 minute intervals by incremental amounts determined by the **CLOSE PERCENTAGE** setpoint. After it is fully closed, it remains there until another surge is detected.

Whenever the Hot Gas valve is partially or fully open, the existing safety check that subtracts the evaporator saturation temperature from the leaving chilled liquid temperature changes the range from standard range of (-2.5°F to +25°F) to (-5.0°F to +25°F). Whenever the Hot Gas Bypass valve is closed or not used, this safety check uses the standard values.

If RS-485 serial communications between the Microboard and the Analog I/O Board are lost continuously for 20 seconds, “WARNING – EXTERNAL I/O – SERIAL COMMUNICATIONS” is displayed on the System Details line of the Display and the Hot Gas valve will remain at the position when communications were lost.

HOT GAS OPERATION WITH VARIABLE GEOMETRY DIFFUSER (VGD)

Since the VGD operates by pulsing the diffuser ring open until stall is detected, there are some conditions where this probing can actually cause a surge. Therefore, to eliminate unnecessary Hot Gas Valve movement, the Hot Gas Valve is not opened on the first surge or when the VGD is closing. When a surge is detected, the Hot Gas Valve will not be opened until a second surge is detected. This gives the VGD a chance to close and stabilize the chiller without opening the Hot Gas Valve. While the VGD operation is inhibiting Hot Gas operation, “VGD Override” (“Override” in software version C.OPT.01.18.307 and earlier) is displayed as the Hot Gas Control Mode.

Whenever the Hot Gas Valve is not closed, the VGD is maintained at the last position. This keeps the VGD at a position of similar surge stability when the system head is later lowered and the Hot gas Valve closes.

MANUAL CONTROL

The Hot Gas Bypass valve can be manually controlled from the Hot Gas Bypass Screen in Service access level. Manual control has priority over Minimum Load Override, Variable Speed Drive Override and Automatic control.

When the OPEN or CLOSE key is pressed, the valve position will be increased or decreased by 5% to a maximum of 100% or minimum of 0%. Each time either key is pressed, the LED in the respective key will illuminate for 2 seconds. The Hot Gas Bypass Control Mode will display “Manual”.

I/O BOARD

The I/O Board supplied for Hot Gas Bypass applications is mounted on the right hand wall inside the control center. This board receives a Hot Gas Bypass Valve position command via RS-485 serial communications from the microboard COM3 port. It converts this command into a 0-10Vdc signal that is applied to the valve. This signal positions the valve over the range of 0% (fully closed) to 100% (fully open). Positions between these extremes are linearly scaled (a 50% position would be achieved with a 5Vdc signal).

There are two different I/O Boards that could be present for Hot Gas Bypass control. Early vintage chillers use Analog I/O Board 371-02514-000. After June 2009, I/O Board 031-02895-000 is used (refer to Section 23; Microboard 031-02430-001 equipped with software version C.OPT.01.21.307 or later is required). Since these boards use different protocols, the microboard must know which board is present in order to be able to communicate with it. The microboard determines which board is present by the features that are enabled:

- If Heat Recovery and/or or Head Pressure control is enabled, it knows the 031-02895-000 board is present and only the 031-02895-000 board is polled.
- If only Hot Gas Bypass is enabled, the microboard automatically determines which board is present. At boot-up, the microboard alternates between polling the 031-02895-000 board and the 371-02514-000 Board. Once a valid response is received from one of these two boards, the communications will continue to only poll that board type.

Below is a description of the interface for each board.

ANALOG I/O BOARD 371-02514-000 (ref FIG 64)

This board communicates with the microboard COM3 serial port using Opto-22 protocol. It is incompatible with microboard 031-01730-000 and 031-02430-000/-001, equipped with any software version.

This board must be configured properly for the Hot Gas control. The on-board Program Jumpers must be configured as follows:

<u>JUMPER</u>	<u>POSITION</u>
J1 & J2	pins 2 & 3
J25 & J26	pins 2 & 3
J13, J39 & J40	pins 1 & 2

A 499 ohm, 1%, ½w resistor is connected between P10-2 and P10-5 to convert the 0-20mA output to a 0-10Vdc output required for the Hot Gas Valve actuator.

I/O BOARD 031-02895-000 (ref FIG 64A)

This board communicates with the microboard COM3 serial port using Modbus protocol. It is only compatible with microboard 031-02430-000/-001 equipped with software version C.OPT.01.21.307 (or later). It is not compatible with microboard 031-01730-000 or any previous software versions.

If the chiller is equipped with Heat Recovery or Head Pressure Control, these features are also interfaced to this board. All Chillers supplied with the Heat Recovery feature are also supplied with the Hot Gas Bypass feature.

SERVICE REPLACEMENT

Replace the defective board with the same part number board. This prevents any compatibility issues.

PRE-ROTATION VANES POTENTIOMETER

A 2.5K ohm potentiometer, mounted on the Pre-rotation vanes control arm, provides a 0-5vdc voltage that represents a PRV position of 0% (fully closed) to 100% (fully open) as displayed on the Hot Gas Bypass Screen. To assure accuracy, a PRV calibration procedure must be performed as detailed in the “System Calibration, Service Setpoints and Reset procedures section of this book.

The potentiometer could be connected to the Variable Speed Drive (VSD) Adaptive Capacity Control (ACC) Board, Analog I/O Board 371-02514-000 or Microboard 031-02430-001. The actual connection point is determined by the motor drive type and hardware configuration as follows:

- If starter type is VSD, the potentiometer is connected to either the ACC Board or the Microboard, depending upon where the ACC function is performed. If the ACC board is present it is connected to the ACC Board J4. If the ACC Board is not present (ACC function performed in the Microboard) it is connected to the Microboard J7.
- If the starter type is not VSD, the potentiometer is connected to either the Analog I/O Board or Microboard depending on which I/O Board is present. If Analog I/O Board 371-02514-000 is present, it is connected to this board at P1. If I/O Board 031-02895-000 is present, it is connected to the Microboard J7.

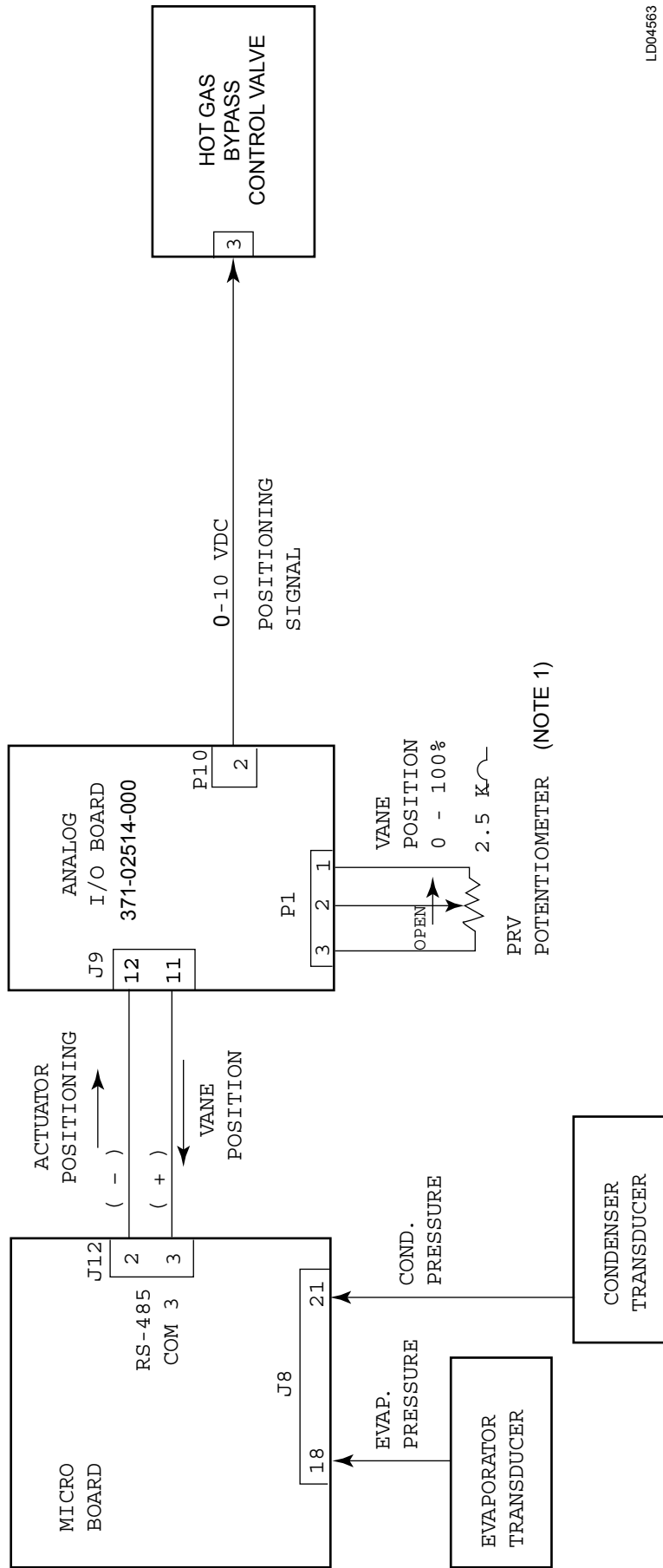

LD04563

Notes:

1. If chiller is equipped with a compressor motor Variable Speed Drive, the PRV potentiometer is connected to either the Adaptive Capacity Control Board (J4) or the Microboard J7, depending on where the ACC function is performed. Refer to explanation in this section.

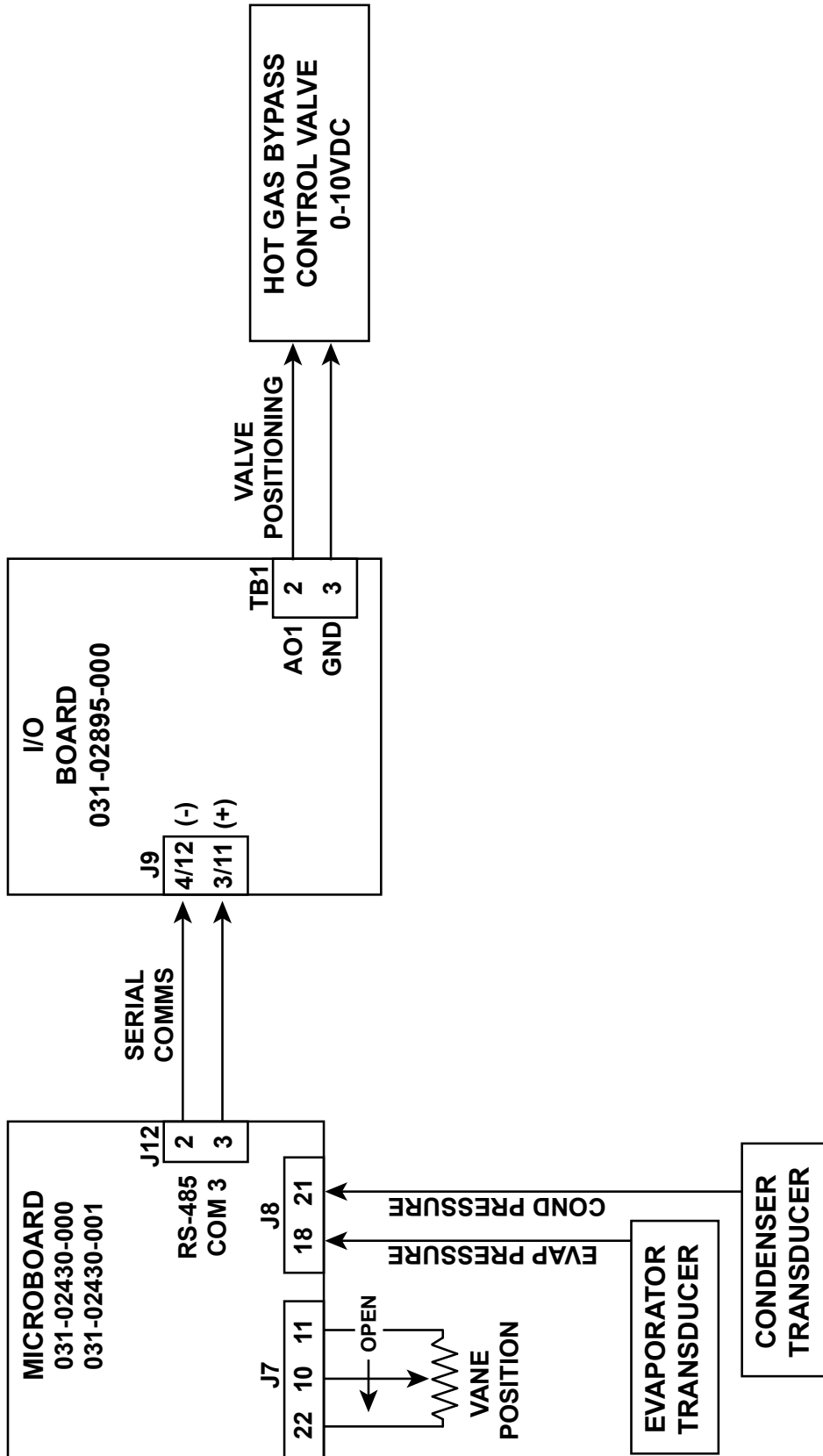

Notes:

1. If chiller is equipped with a compressor motor Variable Speed Drive, the PRV potentiometer is connected to either the Adaptive Capacity Control Board (J4) or the Microboard J7, depending on where the ACC function is performed. Refer to explanation in this section.

FIG. 64A – INTERFACE, HOT GAS BYPASS (I/O BOARD 031-02895-000)

SECTION 21

SMART FREEZE PROTECTION

The **Smart Freeze** feature prevents nuisance chiller shutdowns due to brief periods of chilled liquid flow fluctuations or other brief operating conditions that would normally cause Low Evaporator Pressure Safety shutdowns. With this feature enabled and activated, the chiller is permitted to ride through these temporary conditions. Also, this feature allows the Leaving Chilled Liquid temperature Setpoint to be set as low as 36.0°F. **Smart Freeze** protection can be enabled or disabled at the Keypad, by a Service Technician, using a procedure detailed in the “System Calibration, Service Setpoints and Reset Procedures” section of this book. It **cannot** be used in Brine cooling mode.

The basis of this feature is that the chilled liquid contains an amount of heat, which cannot be eliminated immediately. Therefore, it requires a certain amount of time for the liquid to change to a solid. During this period of time, those parameters that determine when solidification will occur, are evaluated and the appropriate Low Evaporator Temperature shutdown threshold is applied. This threshold could be lower, but not higher than the normal Safety threshold.

Smart Freeze protection uses the Evaporator Refrigerant Temperature as one of the variables to determine when freezing is imminent. If the chiller is equipped with the Evaporator Refrigerant Temperature Sensor (RT7), and the sensor is enabled using the “System Calibration, Service Setpoints and Reset Procedures” section of this book, this value is used as the refrigerant temperature. Otherwise, the Evaporator Saturation Temperature (as derived from the output of the Evaporator Pressure Transducer. The pressure is converted to a temperature via the appropriate refrigerant “pressure/temperature lookup table”) is used as the refrigerant temperature.

When **Smart Freeze** protection is Enabled, the Leaving Chilled Liquid Temperature Setpoint can be set as low as 36.0°F. If set to < 38.0°F, the **LEAVING CHILLED LIQUID – LOW TEMPERATURE** cycling shutdown threshold becomes a minimum of 34.0°F.

Unless **Smart Freeze** protection is **activated**, the fixed Low Evaporator Pressure Safety thresholds (R22 – 54.3 PSIG, 29.6°F) (R134a – 25.0 PSIG, 28.7°F) are used.

SMART FREEZE protection is **activated** only when the feature is enabled **AND** the Leaving Chilled Liquid Temperature Setpoint is < 38°F. Once activated, the total number of seconds that the evaporator refrigerant temperature is below the freeze threshold is counted. The freeze threshold is 32.8°F (refrigerant temp. sensor RT7) or 34.0° (evaporator saturation temp. See Note 1 below.). The count is incremented once for every second the evaporator refrigerant temperature is below the freeze threshold and decremented once for every second it is above the freeze threshold (but is never decremented below zero). Thus if the evaporator refrigerant temperature goes below the freeze threshold for 30 seconds, then goes above it for 10 seconds, then goes below the threshold for 5 seconds, the total number of seconds the evaporator refrigerant temperature was below the freeze threshold was 25 seconds. If Smart Freeze is no longer activated due to the Leaving Chilled Liquid Temperature Setpoint being raised to ≥ 38.0°F, the total number of seconds being tracked is set to zero.

The number of seconds it will take the chilled liquid to freeze is based on how far the evaporator refrigerant temperature is below the freeze threshold as follows:

$$\text{Number of seconds to freezing} = \frac{4053.7}{(\text{freeze threshold} - \text{evaporator refrigerant temperature})}$$

Thus, if the Evaporator Saturation Temperature is being used as the evaporator refrigerant temperature and that temperature is 26.0°F, it would take 8 minutes and 26 seconds for the chilled liquid to freeze.

When the total number of seconds the evaporator refrigerant temperature is below the freeze threshold exceeds the “Number of seconds to freezing”, a safety shutdown is performed and “**EVAPORATOR – LOW PRESSURE – SMART FREEZE**” is displayed on the System details line of the display.

Even though **Smart Freeze** protection is enabled and activated, the Pre-rotation Vanes Load inhibit still occurs at the same thresholds as with normal operation; inhibit at 56.2 PSIG (R22) and 27.0 (R134a). As in normal operation, loading will be allowed when the pressure increases to 57.5 PSIG (R22) and 28.0 PSIG (R134a).

The following is a summary of the operation with **Smart Freeze** enabled and disabled:

SMART FREEZE DISABLED:

- Minimum Leaving Chilled Liquid Setpoint: 38.0°F
- Low Chilled Liquid Temp cycling shutdown threshold: 1° to 34.0°F below the Leaving Chilled Liquid temp Setpoint, as programmed, or a minimum of 36.0°F.
- Low Evaporator Pressure safety shutdown threshold: R22 - 54.3 PSIG (29.6°F); R134a – 25.0 PSIG (28.7°F)
- PRV Load Inhibit: R22 – 56.2 PSIG; R134a – 27.0 PSIG
Load Inhibit disable: R22 – 57.5 PSIG; R134a – 28.0 PSIG

SMART FREEZE ENABLED:

- Minimum Leaving Chilled Liquid Setpoint: 36.0°F
- *If the Leaving Chilled Liquid Temperature Setpoint is $\geq 38.0^\circ\text{F}$:*
 1. The Low Leaving Chilled Liquid Temperature Cycling shutdown threshold: 1 to 34.0°F below the Leaving Chilled Liquid Temperature Setpoint, as programmed, or a minimum of 36.0°F.

2. The Low Evaporator Pressure Safety shutdown threshold is the same as **Smart Freeze Disabled** above.

- If the Leaving Chilled Liquid Temperature Setpoint is $< 38.0^\circ\text{F}$:
 1. The Low Leaving Chilled Liquid Temperature Cycling shutdown threshold: 1 to 3.0°F below the Leaving Chilled Liquid Temperature Setpoint, as programmed, or a minimum of 34.0°F.
 2. Low Evaporator Pressure shutdown threshold: Determined by how far the evaporator refrigerant temperature is below the freeze threshold of 32.8°F (refrigerant temperature sensor RT7) or 34.0°F (Evaporator Saturation Temperature. See Note 1 below.) and the total number of seconds it remains there. Refer to explanation above.
- PRV Load Inhibit: same as **Smart Freeze Disabled** above.
- Load Inhibit Disable: same as **Smart Freeze Disabled** above.

Note 1: The freeze threshold evaporation saturation temperature is 32.0°F on Flash Memory Card version C.MLM.01.01 and earlier.

SECTION 22

SURGE PROTECTION

The surge protection feature detects surge events for Surge Avoidance and the Hot Gas Bypass feature. It provides a running count of the surges detected over the lifetime of the chiller. It allows the user to define how many surges are excessive and how the control will react to an excess surge condition. When excessive surging is detected, it can be configured to shutdown the chiller or initiate a surge correction/avoidance mode or simply display a warning message.

{The detection and counting of surges in this feature is independent of the surge detection/counting performed by the compressor motor Variable Speed Drive (VSD) Adaptive capacity Control (ACC) surge detection. The ACC surge detection creates a surge map used to control the speed of the drive. In new production chillers prior to March 2007, the ACC function and ACC surge detection are performed by the ACC Board (this is called the YORK Protocol configuration). In new production chillers after March 2007, the ACC surge detection is performed by the ACC function in the Microboard and the ACC Board is not present (this is called the MODBUS Protocol configuration). All Medium Voltage Variable Speed Drives (MV VSD) use this later configuration. The surge events detected and accumulated by the ACC function are displayed on the ACC Screen. With software version C.OPT.01.19.307 and later (in Modbus Protocol configuration), there's an "ACC Surge Detected" LED on the SURGE PROTECTION Screen that annunciates the ACC detected surges. This is provided on this screen for reference only. To eliminate counting and reacting to surges caused by the ACC function, the Surge Protection feature only detects and reacts to those surges that occur while the VSD is running at maximum frequency (speed). Refer to SECTION 3A and 12 of this book details of these configurations. Due to service parts replacement, early production chillers could be in the MODBUS Protocol configuration.}

The Surge Protection Screen, accessible from the Compressor Screen, displays all parameters relevant to this feature. All setpoints for this feature are maintained on this screen. The parameters displayed on this screen vary according to the software version and compressor motor type as noted below.

SURGE DETECTION

Surge events are detected by monitoring the relationship between the Condenser pressure and Evaporator pressure while the chiller is running. When the difference between these pressures decreases transiently and remains so for a period of time described below, and then makes a positive transition within 7 seconds (90 seconds with software version C.MLM.01.10B.xxx and later) or C.OPT.01.10B.xxx and later), a surge event has been detected.

The surge detection sensitivity for the Surge Protection feature is set with the SURGE SENSITIVITY setpoint on the Surge protection Screen. It is adjustable over the range of 0.3 (default) to 1.3. Smaller values increase the sensitivity. (This sensitivity setting is not to be confused with the SURGE SENSITIVITY setpoint on the ACC Details Screen. The SURGE SENSITIVITY setpoint on that screen adjusts the sensitivity of the ACC surge detection feature in the Microboard when configured in MODBUS Protocol configuration (software version C.OPT.01.16.307 and later).

The Evaporator pressure transducer output is subtracted from the Condenser pressure output to determine the differential. If either of the following negative transitions occur in the differential followed by a 0.061VDC positive differential transition within 7 seconds (90 seconds for P and Q compressors with software version C.MLM.01.10B.xxx and later) or C.OPT.01.10B.xxx and later), a surge event is detected:

- If the differential decreases $\geq 0.6\text{VDC}$ for ≥ 0.260 seconds.
- If the differential decreases $\geq x.x\text{VDC}$ for ≥ 0.390 seconds.

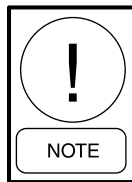

$x.x\text{VDC}$ calculated as $[(\text{surge sensitivity setpoint} \times 300) \times 1.22] \div 1000$

Each time a surge is detected by the Surge Protection feature, the SURGE AVOIDANCE SURGE DETECTED indicator illuminates momentarily (if equipped with a VSD or MV VSD, this feature only detects surges while the drive is running at maximum frequency). If equipped with software version C.OPT.01.18.307 or earlier, the indicator is labeled SURGE DETECTED and it illuminates whenever a surge detected, regardless of VSD operating frequency.

If equipped with a VSD (in MODBUS protocol configuration) or a MV VSD, the ACC SURGE DETECTED indicator illuminates momentarily when a surge is detected by the ACC function in the Microboard, while the drive is running at less than maximum frequency. Software version C.OPT.01.18.307 or earlier does not have this indicator.

The SURGE AVOIDANCE SURGE COUNT (displayed as “Total Surge Count” in software version C.OPT.01.18.307 and earlier) is the total number of surges detected by the Surge Protection feature (if equipped with a VSD or MV VSD, this feature only detects surges while the drive is running at maximum frequency). The SURGE AVOIDANCE SURGE COUNT can be cleared using an ADMIN password following procedure in Section 23 of this book.

The SURGE WINDOW COUNT accumulates the number of surges that occur within the SURGE WINDOW TIME. This time is programmable over the range of 1 to 5 minutes using the COUNT WINDOW setpoint. The number of surges that occur within the SURGE WINDOW TIME are compared to the COUNT LIMIT setpoint (4 – 20) to determine if an excess surge condition exists, as explained below.

EXCESS SURGE DETECTION

An excess surge condition is detected by comparing the number of surge events that occur in a selectable time period to a selectable threshold.

If the number of surge events (Surge Window Count) detected in the time period programmed as the COUNT WINDOW setpoint (1 to 5 minutes; default 5) (default 3 with Software version C.MLM.01.09.xxx (and later) or C.OPT.01.09.301 (and later)) exceed the threshold programmed as the COUNT LIMIT setpoint (4 to 20; default 4) (default 15 with Software version C.MLM.01.09.xxx (and later) or C.OPT.01.09.301 (and

later)) an excess surge condition has been detected.

Unless the SHUTDOWN or EXTENDED RUN features have been enabled, as explained below, the chiller will continue to run under the same conditions displaying “Warning – Excess Surge Detected”. This message will be displayed until manually reset with the Warning Reset key in Operator access level.

SURGE PROTECTION

The Control Center can be configured to take the following courses of action when an excess surge condition has been detected. The SHUTDOWN setpoint is used to invoke a safety shutdown. The EXTENDED RUN setpoint is used to invoke a special 10 minute surge correction/avoidance mode that temporarily eliminates the conditions causing the surging, while allowing the chiller to continue to run. If the chiller is equipped with the Hot Gas Bypass feature and/or a compressor motor Variable Speed Drive (VSD), certain Hot Gas valve position and VSD speed criteria must be met before the Shutdown or Extended Run functions are performed as explained below.

When a surge is detected, the following courses of action are taken:

- If the SHUTDOWN setpoint is Enabled, and the EXTENDED RUN setpoint is Disabled, a safety shutdown will be performed and “Surge Protection - Excess Surge” is displayed.
- If the SHUTDOWN setpoint is Disabled and the EXTENDED RUN setpoint is Enabled, the Pre-rotation Vanes are driven closed for 10 minutes and “Warning – Surge Protection – Excess surge Limit” is displayed. When the 10 minutes have elapsed, if the Surge Window Count is \leq the Count Limit, this message and load inhibit are automatically cleared, otherwise another 10 minute period is initiated. Alternating with this message is “Warning – Excess Surge Detected” that is displayed until manually reset with the Warning Reset key in OPERATOR access level. During the 10-minute period, a countdown timer on the Surge Protection Screen displays the time remaining in the period. See Hot Gas Bypass and compressor motor Variable Speed Drive exception above.

- If both the SHUTDOWN and EXTENDED RUN setpoints are Enabled, the 10 minute Extended Run period is invoked as above. However, if the SURGE WINDOW COUNT exceeds the COUNT LIMIT at the end of the 10 minute Extended Run period, a safety shutdown is performed and “Surge Protection – Excess Surge” is displayed.

**HOT GAS BYPASS/COMPRESSOR MOTOR
VARIABLE SPEED DRIVE (VSD)
APPLICATIONS**

Equipped with Hot Gas:

The Hot Gas valve position must be 100% before the Extended Run mode is implemented.

Equipped with VSD:

Software version CMLM.01.08.xxx (and earlier) or C.OPT.08A.300 - The Extended Run mode will not be implemented unless the VSD output frequency is at maximum.

Software version C.MLM.01.09.xxx (and later) or C.OPT.09.301 (and later) – The Extended Run mode, Shutdown mode and Excess Surge Warning message will not be implemented unless the VSD output frequency is at maximum.

Equipped with both Hot Gas and VSD:

Software version C.MLM.01.08.xxx (and earlier) or C.OPT.08A.300 – The Extended Run mode will not be implemented unless the Hot Gas valve position is 100% and the VSD output frequency is at maximum.

Software version C.MLM.01.09.xxx (and later) or C.OPT.01.09.301 (and later) – The Extended Run mode, Shutdown mode and Excess Surge Warning message will not be implemented unless the Hot Gas Valve position is 100% and the VSD output frequency is at maximum.

SECTION 22A

VARIABLE GEOMETRY DIFFUSER

(SEE FIG'S 64A & 64B)

Certain YORK compressors are equipped with a Variable Geometry Diffuser (VGD). It is used to reduce rotating stall conditions and associated stall noise. Stall may occur at low load conditions with high head. A mechanical ring, located in the diffuser passage after the impeller discharge, is mechanically operated through linkages via an electric actuator like that used to operate the Pre-rotation vanes. It is closed (extended) to narrow the diffuser gap. It is opened (retracted) to open the diffuser gap. An internal actuator end switch prevents travel beyond the fully open or closed positions. The VGD Limit Switch indicates when the VGD is fully closed. The switch closes when the VGD is in the fully closed position. The switch status is displayed on the VGD Screen and VGD Setpoints Screen (Software version C.MLM.01.14.xxx (and later) or C.OPT.01.14.306 (and later)). It's displayed as CLOSED when the VGD is in the full closed position. Otherwise, it is displayed as OPEN. In response to a stall condition, the ring is closed as much as necessary to eliminate the stall. Since stall is caused by reduced gas flow through the compressor, narrowing the diffuser gap reduces the cross sectional area through which the gas flows, thereby increasing the gas velocity through the compressor. The diffuser ring is also closed in response to surge conditions as described below.

Software version C.MLM.01.10.xxx (and later) or C.OPT.01.10.302 (and later) is required for this feature.

The Variable Geometry Diffuser Screen displays all parameters relevant to this feature. All setpoints related to this feature are maintained on the Variable Geometry Diffuser Setpoints Screen.

STALL DETECTION (REF FIG 64A)

Stall noise in the compressor discharge is detected as gas pressure pulsations. A **Stall Pressure Transducer** (025-39464-000 or 025-40088-000), mounted in the discharge scroll of the compressor, detects the pressure pulsations and outputs DC voltage pulsations to the **Stall Detector Board** (031-02418-000 or 031-2418-001). This board converts the voltage pulsations into an analog voltage that represents the magnitude of the stall

noise. This analog voltage is displayed on the Variable Geometry Diffuser Screen as "Stall Detector Voltage" and is input to the Microboard where it is compared to the Low Limit and High Limit setpoint thresholds to determine if the stall noise is acceptable or unacceptable. In a typical YK chiller, a signal below 0.5 VDC indicates little or no stall. A signal above 0.8 VDC indicates stall noise is present.

SURGE DETECTION

Surge events are sensed as described in the HOT GAS BYPASS Section 20 and SURGE PROTECTION Section 22 of this manual.

AUTOMATIC OPERATION

The VGD operation is illustrated in the STATE DIAGRAM illustrated in FIG. 64B. The "States" are shown in circles. They are Stall Waiting, Stall Reacting, Probing, Surge Reacting, Surge Waiting and Hot Gas Override. Arrows on the diagram indicate actions that move the control from one "State" to another. For clarity, different arrow styles are used for Stall (___), Surge (___) and Hot Gas (___) response actions. During chiller operation, the current state is displayed as the "Control Status" on the Variable Geometry Diffuser Screen.

In general, the VGD is maintained in the most open position possible that does not allow stall. It is fully open when the chiller is started. If stall occurs, it is driven toward the close position until the stall is eliminated. After a wait period, it is again pulsed open until either a stall occurs or the fully open position is reached, whereupon the cycle repeats. In response to a surge, it is driven toward the close position for a selectable period of time. After a wait period, it is again pulsed open unless another surge occurs, whereupon Hot Gas operation overrides VGD operation and the VGD is held in place.

The Diffuser Gap Open and Diffuser Gap Close LED's on the Variable Geometry Diffuser Screen illuminate when the program is initiating the respective output.

The following describes the operating states:

Chiller Off, Prelube or Coastdown:

The VGD diffuser gap is driven fully open.

Stall Waiting:

This state is entered on startup, after a Stall Reaction, or Hot Gas Valve closure. The VGD is held in last position until one of the following occurs:

- The PROBE WAIT time period (0.5 – 15 minutes; default 10; as programmed with the PROBE WAIT time setpoint) expires. When the timer expires, the Probing state is entered. The time remaining in the PROBE WAIT time period is displayed on the Variable Geometry Diffuser Screen as “Time Remaining”.
- A stall is detected (stall detector board output goes above the HIGH LIMIT setpoint). Enters Stall Reacting state.
- A surge is detected. Enters Surge Reacting state.
- The compressor pre-rotation vanes (PRV) position increases more than the PRV OFFSET (1-5%; default 3; as programmed with the PRV OFFSET setpoint). Enters Probing state. The PRV position is displayed on the Variable Geometry Diffuser Screen as 0% (fully closed) to 100% (fully open). Note: Setting the PRV OFFSET setpoint to 0% disables this function. Probing will be initiated based on PROBE WAIT time only.

Probing:

In this state, the VGD mechanism is opened in pulses to open the diffuser gap. The pulses are initiated every 10 seconds. The duration of the pulses are defined by the OPEN PULSE setpoint (1-9 seconds; default 2). This probing continues until the Stall Detector Board output exceeds the HIGH LIMIT setpoint (0.5 – 1.2Vdc; default 0.8) to indicate stall is present or a surge is detected. Typically, at lower loads below 70%, stall will be sensed and controlled before a surge occurs. At higher loads and very high heads or lift, a surge can occur while probing which may be momentary in nature and not evidenced as stall noise. The number of times the Stall Detector Board output goes above the HIGH LIMIT setpoint threshold is displayed on the VGD Setpoints Screen as the “VGD Count”. This count can be reset using an ADMIN access level. The accumulated time the Stall Detector Board output voltage is greater than the “High Limit” threshold is displayed on the VGD Screen as “VGD Time”.

Stall Reacting:

If a stall is detected from either the Probing or Stall Waiting states, the state is changed to Stall Reacting. In this state, the diffuser gap is closed until the Stall Detector Board output drops below the LOW LIMIT setpoint (0.4 – 0.8Vdc; default 0.6). After Stall Reacting, the state

returns to Stall Waiting. If equipped with the optional Hot Gas Bypass feature and the Hot Gas valve position is greater than 0% when the stall is detected, the VGD is held in its last position. It is not driven closed.

Surge Reacting:

The VGD is closed for a specific time period, defined by the SURGE REACT time setpoint (1-30 seconds; default 5). A surge is detected as detailed in the “Surge Protection” and “Hot Gas Bypass” sections of this manual. The Surge Detected LED on the Variable Geometry Diffuser Screen illuminates for 5 seconds each time a surge is detected. The program looks at a change in the condenser minus evaporator pressures over a short time period to detect a back flow or surge condition of the compressor. A surge is generally of more concern and potentially damaging to the compressor than stall. So, if a surge is detected, this overrides any of the Stall action states. Opening the diffuser gap may lower the lift capability of the machine. Therefore, there are some conditions where the Probing can actually cause a surge. In this case it is likely that simply closing the diffuser gap some amount will stabilize the compressor. Therefore, for units with VGD and Hot Gas options, the Hot Gas Bypass Valve will not be opened on the first surge or during the time the VGD is closing.

Surge Waiting:

The VGD is held in last position for a wait time, defined by the PROBE WAIT time Setpoint (0.5 – 15 minutes; default 10). During this period, any stall conditions are ignored and the controls will look for a second surge. If a second surge occurs during, normal Hot Gas Bypass Control takes over and Hot Gas Bypass Override state is entered. If there are no other surges detected during this period, the VGD returns to Probing.

The time remaining in the PROBE WAIT time period is displayed on the Variable Geometry Diffuser Screen as “Time Remaining”.

Hot Gas Bypass Override:

Applies for units with optional Hot Gas Bypass. Whenever the Hot Gas Bypass valve position is greater than 0%, the VGD mechanism will be kept at last position. This keeps the VGD at a position of similar surge stability when the system head is later lowered and the hot gas valve closes. This state remains in effect until the Hot Gas valve position returns to 0% (or if equipped with software version C.OPT.01.21.307 and later, a stall is detected) whereupon it returns to the Stall Reacting State.

Hot Gas Bypass operates as described in the Hot Gas Bypass section 20 of this manual. Except that on surge response, the Hot Gas Valve will not be opened until a second surge is detected. The Hot Gas Minimum Load Override function is not affected by VDG operation.

PRV-VGD Inhibit:

If the Pre-rotation Vanes position exceeds the PRV-VGD Inhibit Setpoint (40% to 100%), the VGD is pulsed open per the Open Pulse setpoint. While this is in effect, Control Status displays “PRV Position Override”.

STALL SENSOR VALIDATION

(Software version C.MLM.01.14.xxx (and later) or C.OPT.01.14.306 (and later))

This feature verifies the operation of the Stall Pressure Transducer by comparing its voltage output to the voltage output of the Condenser Pressure Transducer. Since both transducers are measuring essentially the same pressure, both outputs should be within an acceptable range of each other. If the Stall Transducer is not reading accurately, a warning message is displayed and the Variable Geometry Diffuser operation is disabled.

While the chiller is running, the outputs of the Stall Transducer and Condenser Transducer are compared. If the difference between them exceeds 0.28 Vdc for 3 continuous minutes, the VGD is driven to the full open position and “Warning – Condenser or VGD Sensor Failure” is displayed. The VGD is held in the open position until the warning is manually cleared. It can be cleared when the voltages are within the acceptable range of each other and the Warning Reset key is pressed in Service access level. When the warning is cleared, the VGD returns to normal operation.

The Stall Pressure Transducer unprocessed DC voltage output passes through the Stall Detector Board J2-2 and is connected to the Microboard at J8-1. This value is then used for comparison to the condenser transducer.

EXTREME STALL MONITOR

(Software version C.MLM.01.14.xxx (and later) or C.OPT.01.14.306 (and later))

The Variable Geometry Diffuser ring can be damaged by operating in extreme stall for long periods of time. To prevent damage, the VGD is disabled during extreme stall conditions and a warning message is displayed.

While the chiller is running, if the Stall Detector Voltage (output of the Stall Detector Board) exceeds twice the HIGH LIMIT Setpoint, for the duration programmed as the EXTREME STALL DURATION Setpoint (10 to 20 minutes; default 10), the VGD is driven to the full open position and “Warning – Conditions Override VGD” is displayed. The VGD is held in the open position until the warning is manually cleared. It can be cleared after the Stall Detector Voltage returns to less than two times the HIGH LIMIT Setpoint. Press the Warning Reset key in Service access level to clear. After it is cleared, the VGD returns to normal operation.

The Extreme Stall condition is not checked under the following conditions:

- While the VGD is in Manual control mode.
- While the VGD is fully closed (VGD Limit Switch closed).
- While the Pre-rotation vanes position is greater than the PRV VGD INHIBIT Setpoint.

MANUAL OPERATION

The VGD can be manually controlled from the Variable Geometry Diffuser Screen in Service access level, whether the chiller is running or not. Pressing the OPEN, CLOSE or HOLD key invokes manual operation and the VGD Control Mode displays MANUAL. Each time the OPEN or CLOSE keys are pressed, the respective output is energized and the associated LED illuminates. Pressing the HOLD key causes the Hold LED to illuminate and the VGD to be held in its present position. Pressing the AUTO key invokes automatic operation and AUTO is displayed as the control mode.

SETPOINTS

The following setpoints are entered on the Variable Geometry Diffuser Setpoints Screen. They require SERVICE access level.

- Enable/Disable - Enables or Disables the VGD feature. Default is Disabled. Chiller must be stopped to change this setpoint.
- Surge React (1-30 seconds; default 5) - Specifies the duration of the close pulse applied to the VGD in response to a surge.
- PRV Offset (0-5%; default 3) – If the VGD control is in the Stall Waiting state and the Pre-rotation vanes position increases by more than this value, the Probing state will be entered. If the PRV Offset is set to 0%, the Stall Waiting state is performed based only on the “Probe Wait” setpoint interval.

- Probe Wait (0.5-15 minutes; default 10) – Specifies how long the VGD control remains in the Stall Waiting or Surge Waiting states before entering the Probing state.
- Open Pulse (1-9 seconds; default 2) – Specifies the length of the open pulse applied to the VGD during 10 second periods while in the Probing state.
- High Limit (0.5-1.2Vdc; default 0.8) – Specifies the Stall Detector Board output voltage that represents an acceptable amount of stall noise. Above this value is unacceptable.

The minimum difference between the High Limit setpoint and the Low Limit setpoint is 0.1 vdc. If a Low Limit setpoint is entered which is less than 0.1vdc below the High Limit setpoint, the High Limit setpoint is adjusted so that it is 0.1vdc above the newly entered Low Limit value.

- Low Limit (0.4-0.8vdc; default 0.6) – in the Stall Reacting State, the VGD is driven closed until the Stall Detector Board output voltage decreases to this level.

The minimum difference between the High Limit setpoint and the Low Limit setpoint is 0.1 vdc. If a Low Limit setpoint is entered which is less than 0.1vdc below the High Limit setpoint, the High Limit setpoint is adjusted so that it is 0.1vdc above the newly entered Low Limit value.

- Extreme Stall Duration (10 to 20 minutes; default 10 minutes)(Software version C.MLM.01.14.xxx (and later) or C.OPT.01.14.306 (and later))– Specifies the maximum allowed time an extreme stall condition can exist before the Variable Geometry Diffuser operation is disabled (and driven full open) to protect it from damage.
- PRV VGD Inhibit (40% -100%; default 95%) (Software version C.MLM.01.14.xxx (and later) or C.OPT.01.14.306 (and later)) - While the re-rotation vanes position is greater than this setpoint, Extreme Stall conditions are not checked, the VGD control is inhibited and the VGD will be pulsed open according to the OPEN PULSE Setpoint. While this is in effect, “PRV Position Override” is displayed as Control Status.

PRE-ROTATION VANES POSITION

The Pre-rotation Vanes position, as used by the VGD control, is provided by a potentiometer mounted to the PRV control arm. The potentiometer interface varies according to how the chiller is equipped as follows:

If the chiller is equipped with a compressor motor Variable Speed Drive, the potentiometer is connected to either the Adaptive Capacity Control (ACC) Board or the Microboard, depending on where the ACC function is performed. If the ACC Board is present, the potentiometer is connected to the ACC Board J4. In applications where the ACC functionality is contained in microboard 031-02430-001 (ACC Board not used), the potentiometer is connected to the Microboard J7.

If the chiller is not equipped with a Variable Speed Drive, but is equipped with the Hot Gas Bypass option, the PRV potentiometer is connected to either the Analog I/O Board or Microboard depending on which I/O Board is present. If Analog I/O Board 371-02514-000 is present, it is connected to this board at P1. If I/O Board 031-02895-000 is present, it is connected to the Microboard J7.

If the chiller has neither a Variable Speed Drive nor the Hot Gas option, the potentiometer is connected directly to the Microboard at J7.

I/O BOARD

Chillers equipped with this feature are supplied with and require I/O Board 031-01743-002. This board is populated with the required triacs Q3 and Q4 that apply the open and close signals to the VGD actuator. I/O Board 031-01743-001 does not contain required triacs Q3 and Q4.

STALL TRANSDUCER

Detects stall noise as high frequency pressure fluctuations in the discharge scroll of the compressor. It converts the pressure pulsations to DC voltage pulsations and applies them to the Stall Detector Board. Early vintage chillers were shipped with Stall Transducer 025-39464-000. Later chillers are shipped with Stall Transducer 025-40088-000. These transducers require different wiring connections at the transducer. Check the part number of the replacement transducer and make connections at the transducer connector as follows:

Transducer 025-39464-000

- pin 1 - signal out - WHT
- pin 2 - ground - BLK
- pin 3 - +5vdc supply voltage - RED

Transducer 025-40088-000

- pin 1 - +5vdc supply voltage - RED
- pin 2 - ground - BLK
- pin 3 - signal out - WHT

STALL DETECTOR BOARD

The Stall Detector Board (031-02418-000) converts the Stall Transducer DC voltage pulsations to an analog DC voltage output (J2-4) that represents the magnitude of stall noise and applies it to the Microboard (J7-23). This board also provides a path for the Stall Transducer unprocessed DC voltage pulsations output to be connected from J2-2 to the Microboard (J8-1). This output is used for the Stall Sensor Validation feature.

There are two versions of the Stall Detector Board as follows:

031-02418-000

Supplied in new production chillers and as replacement part until June 2007.

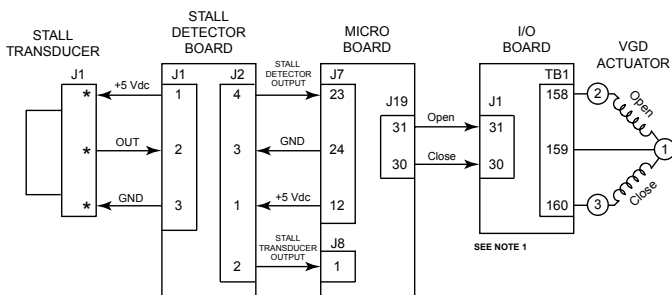

NOTE:
Requires I/O Board 031-01743-002
* Refer to PIN Connections above

LD09467b

031-02418-001

Supplied in new production chillers and as replacement part after June 2007. This board contains a filter that removes the noise associated with high gas flow/low head conditions and thus prevents VGD closing in response to conditions that are not true stall conditions. Shunt jumper JP1 allows operation with or without the filter. With JP1 in the ENHANCED position (on pins 1&2), the filter is engaged. With it in the STANDARD position (on pins 2 & 3), the filter is not engaged and would operate the same as the -000 board above. Use the following guidelines:

- **ENHANCED Mode** – The board is shipped configured in this mode. In this mode, it filters the noise associated with high gas flow/low head conditions and thus prevents VGD closing in response to conditions that are not true stall conditions. The presence of this filter could require adjustment of the setpoints as follows: The Stall Detector Board outputs an analog voltage (displayed as “Stall Detector Voltage” on the VGD Screen) that represents the magnitude of stall noise present. When it reaches the value programmed as the HIGH LIMIT Setpoint (typically set to 0.8vdc), the VGD closes until the voltage decreases to the LOW LIMIT Setpoint (typically set to 0.6Vdc). Since the filter causes the “Stall Detector Voltage” to typically run 0.2 to 0.3vdc lower than STANDARD mode for the same condition, it may be necessary to lower the HIGH LIMIT and LOW LIMIT Setpoints if valid stall conditions are not being detected or surge occurs before stall is detected. Ideally, stall should be detected before surge occurs, allowing the VGD to react prior to surge. Also, since the PRV POSITION – VGD INHIBIT setpoint was the original vehicle to avoid VGD reaction to high gas flow/low head conditions, this setpoint should be set to 95% or 100% to avoid interference when ENHANCED mode is selected.
- **STANDARD Mode** – This mode should not be used unless under the advisement of JCI Tech Support. Provides the same operation as the 031-02418-000 board. Does not filter high gas flow/low head noise conditions as described in ENHANCED mode above.

FIG. 64A – VARIABLE GEOMETRY DIFFUSER BLOCK DIAGRAM

SECTION 23

LARGE TONNAGE CHILLER (LTC) I/O BOARD

031-02895-000/001

Beginning August 2009, new chillers equipped for Hot Gas Bypass, Heat Recovery and/or Head Pressure Control options will be equipped with Input/Output Board 031-02895-000. It provides both Analog and Digital input/output capability to the Microboard from external devices. FIG. 65 is a top level block diagram of this board. Figures 65A through 65G show details of the I/O circuits and should be referred to while reading the following description of the board operation. FIG. 66 is a board layout showing component identification.

The board is manufactured with either a -000 or -001 part number suffix. The -000 board is only populated with the components required for options requiring small additional I/O counts. The -001 board is for future use.

This board operates from +12vdc (TP3) and +24Vdc (TP4) power supply voltages. The +12vdc applied to the +5vdc regulator produces a +5vdc regulated output (TP2), which causes the POWER LED (CR3) to illuminate. These voltages are referenced to GND (TP1).

Power fail circuits detect low DC voltage and put the processor into a reset state as long as the voltage is below a threshold. This prevents the processor from processing data while the DC Voltage is below the minimum required for stable circuit operation. The low voltage reset thresholds are:

- +5Vdc supply @ 4.41Vdc-4.87Vdc
- +12Vdc supply @ 9.6Vdc-11.2Vdc

When the I/O Board is operating, the STATUS LED (CR8) flashes at a regular interval (1/sec) indicating that the board is functional.

This board communicates with the Microboard COM 3 serial port (J12) using Modbus Protocol RS-485 serial communications. When a read/write request is sent from the microboard, the microboard's TX3 (CR15) LED illuminates. When that request is received at the I/O Board, the I/O Board's RX (CR4) LED illuminates. When the I/O Board responds, the I/O Board's TX (CR5) LED illuminates. When the response is received at the microboard, the microboard's RX3 (CR16) illuminates.

Each read/write request from the microboard contains a Modbus Net address. In order for the I/O Board to respond to the microboard's requests, the Modbus Net

address of the I/O Board must match the one sent from the microboard. The Modbus Net address of the I/O Board is set with 4 position DIP switch SW1, labeled NET ADDRESS. This should be set to "1" by setting SW1-1 to ON and the other segments to OFF.

The operating program is stored in the processor. The program is downloaded into the processor through the J1 programming port at the time of board manufacture. Service replacement boards are provided preloaded with the proper software. It is not necessary to field load software into the board.

This board is only compatible with microboard 031-02430-000/-001 equipped with software version C.OPT.01.21.307 (or later). It cannot be used with microboard 031-01730-000 or any previous software versions.

Refer to the following sections of this book for a description of how this board is interfaced for these applications:

- Hot Gas Bypass - Section 20
- Heat Recovery – Section 24
- Head Pressure Control - Section 25

Important! These are not general purpose I/O points available for field use. Unless specifically listed in above referenced sections of this book, the I/O point cannot be used.

DIGITAL INPUTS

120vac Digital Inputs

These inputs accept a 120Vac input. Figure 65A is a detail of this input and is representative of all of these inputs. Each input is applied to the respective (+) and (-) input. Each input is applied to an opto-coupler circuit that converts the AC voltage to a DC voltage. Each input has an LED associated with it. The respective LED illuminates when the 120Vac input is present. Otherwise, it is extinguished. The -000 board is component populated for 2 inputs. The -001 board is populated for 6 inputs.

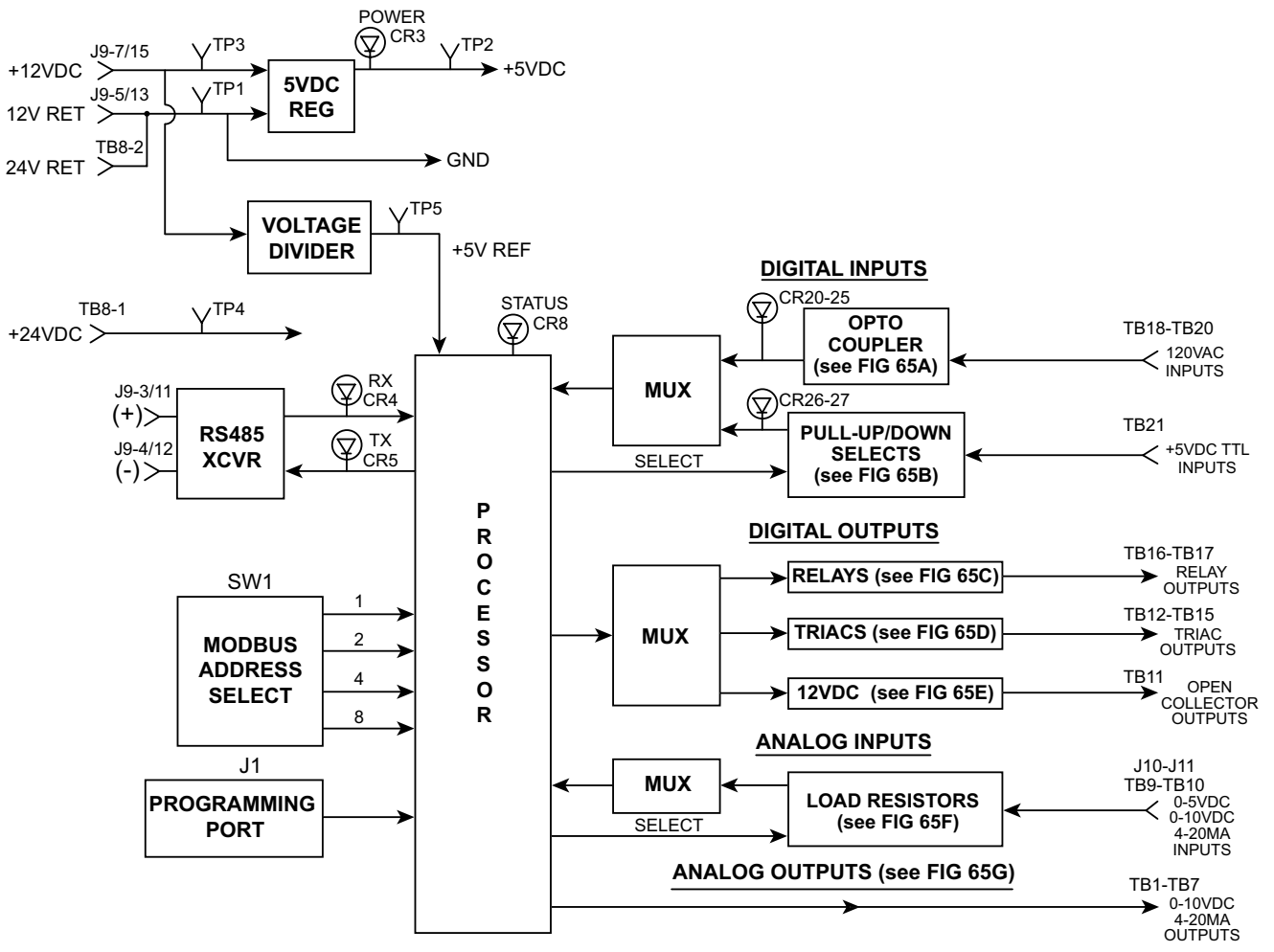

FIG. 65 – LTC I/O BOARD BASIC BLOCK DIAGRAM

LD14232

INPUT	CONNECTION	LED
DI1	TB20-1(+) -2(-)	CR20
DI2	TB20-3(+) -4(-)	CR21
DI3	TB19-1(+) -2(-)	CR22 (-001 board only)
DI4	TB19-3(+) -4(-)	CR23 (-001 board only)
DI5	TB18-1(+) -2(-)	CR24 (-001 board only)
DI6	TB18-3(+) -4(-)	CR25 (-001 board only)

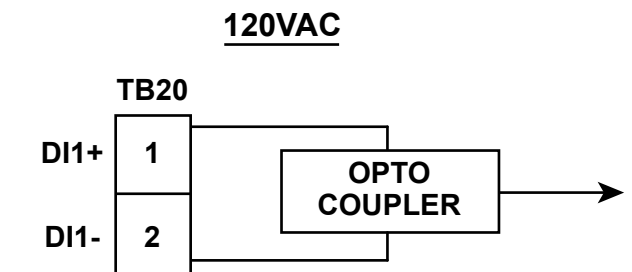

FIG. 65A – 120VAC DIGITAL INPUT

LD14233

+5vdc Digital Inputs (-001 Board only)

There are 2 each +5vdc TTL inputs. FIG 65B is a detail of an input and is representative of all of these inputs. Each input accepts an open/close input that can be configured in either pull-up configuration (+5vdc when open/0Vdc when closed) or pull-down configuration (0Vdc when open/+5vdc when closed). It is connected between the +5vdc and the DI input for a pull-up configuration; between the Gnd and DI input for a pull-down configuration. Under program control, the pull-up/pull-down selector switch connects the input load resistor to either +5vdc (pull-up) or ground (pull-down) per the requirements of the input.

<u>INPUT</u>	<u>CONNECTION</u>	<u>LED</u>
DI7	TB21-1 +5vdc -2 DI7 -3 Gnd	CR26
DI8	TB21-4 +5Vdc -5 DI8 -6 Gnd	CR27

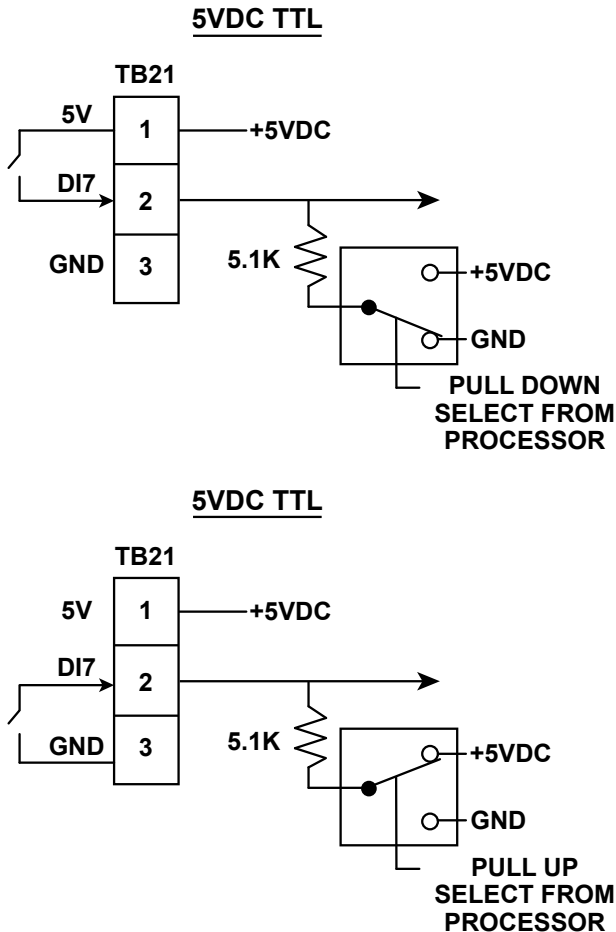

FIG. 65B – +5VDC DIGITAL INPUT

LD14233

DIGITAL OUTPUTS

Relay Outputs (-001 Board only)

There are 2 each 120/240Vac Relay contact outputs. FIG 65C is a detail of an output and is representative of all these outputs. Each relay has one set of normally open contacts that are closed and opened under program control. The relay contact rating is 250Vac, 5 amps resistive, 2 amps inductive. Each output is connected between the respective COM(X) and NO(X) terminals.

<u>OUTPUT</u>	<u>CONNECTION</u>
DO1	TB17-1 COM1 -2 NO1
DO2	TB16-1 COM2 -2 NO2

RELAY OUTPUTS

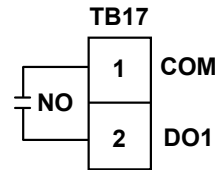

FIG. 65C – RELAY OUTPUTS

LD14234

Triac Outputs (-001 Board only)

There are 4 each 24/120Vac triac outputs. FIG 65D is a detail of an output and is representative of all these outputs. Each output can switch 2 amps at 17-132Vac. Each output is connected between the respective RET and DO(X) connection.

<u>OUTPUT</u>	<u>CONNECTION</u>
DO5	TB15-1 Ret -2 DO5
DO6	TB14-1 Ret -2 DO6
DO7	TB13-1 Ret -2 DO7
DO8	TB12-1 Ret -2 DO8

TRIAC OUTPUTS

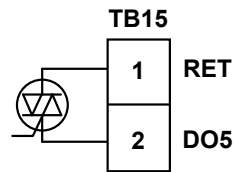

FIG. 65D – TRIAC OUTPUTS

LD14234

Open Collector Outputs (-001 Board only)

There are 2 each open collector outputs. FIG 65E is a detail of an output and is representative of all these outputs. Each output switches a ground connection through an onboard solid state device to an external load connected to the board supplied +12Vdc power source. Each output is connected between the respective +12Vdc and DO(X) terminals

<u>OUTPUT</u>	<u>CONNECTION</u>
DO3	TB11-1 +12Vdc -2 DO3
DO4	-3 +12Vdc -4 DO4

OPEN COLLECTOR

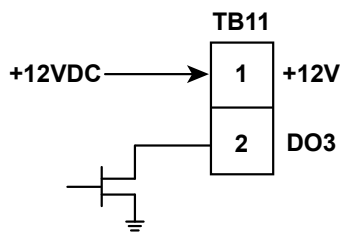

FIG. 65E – OPEN COLLECTOR

LD14234

ANALOG INPUTS

There are 8 each analog inputs on the -000 board and 16 each on the -001 board. FIG 65F is a detail of this input and is representative of all these inputs. Each input accepts either a 0-5Vdc, 0-10Vdc, 4-20mA, Transducer or Thermistor input. The on-board software configures each input per the requirements of the input type. The configuration consists of selecting the appropriate input series resistor to ground. The software closes the appropriate switch(s) (1, 2, 3), selecting the appropriate input resistor. FIG 65F shows the switch settings and resistance values for each input type.

Inputs AI7 and AI8 have dual input connectors that allow either a pin/socket connection or screw terminal connection as shown below

Thermistors and Transducers operate from the board supplied +5Vdc supply voltage. To compensate for a varying +5vdc supply voltage, this voltage is compared to a precise +5vdc reference. The output of the device is adjusted according to any difference.

ANALOG INPUTS

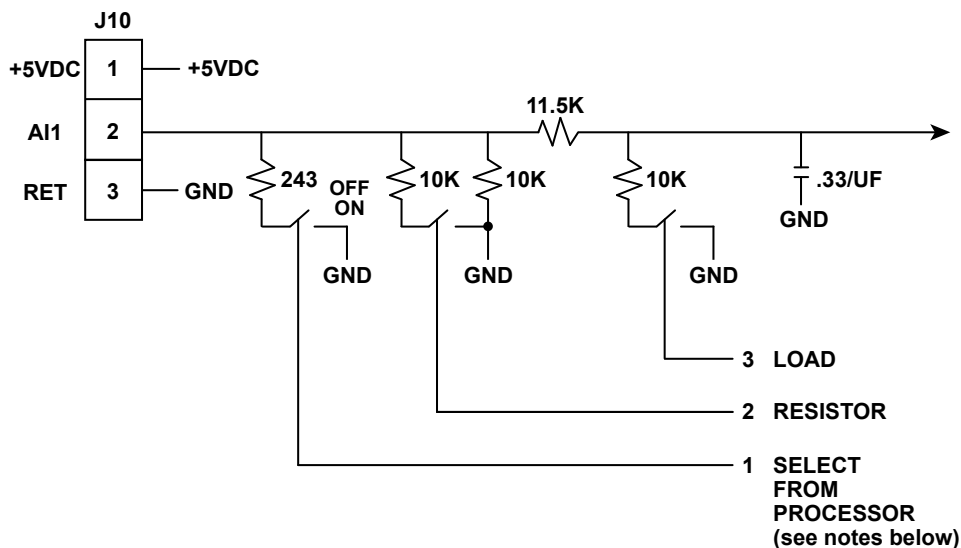

	<u>1</u>	<u>2</u>	<u>3</u>	<u>Resistor (0 Ohms)</u>
0-5VDC, TRANSDUCER, THERMISTOR	OFF	OFF	OFF	10K
0-10VDC	OFF	OFF	ON	10K-11.5K
THERMISTOR	OFF	ON	OFF	5K
4-20mA	ON	OFF	OFF	243

FIG. 65F – ANALOG INPUTS

LD14235

<u>INPUT</u>	<u>CONNECTION</u>
AI1	J10-1 +5vdc -2 AI1 -3 Ret
AI2	J10-4 +5vdc -5 AI2 -6 Ret
AI3	J10-7 +5vdc -8 AI3 -9 Ret
AI4	J10-10 +5vdc -11 AI4 -12 Ret
AI5	J10-13 +5Vdc -14 AI5 -15 Ret
AI6	J10-16 +5Vdc -17 AI6 -18 Ret
AI7	J10-19 +5Vdc -20 AI7 or TB9-1 -21 Ret TB9-2
AI8	J10-22 +5Vdc -23 AI8 or TB9-3 -24 Ret TB9-4
AI9	J11-1 +5Vdc (-001 board only) -2 AI9 -3 Ret
AI10	J11-4 +5Vdc (-001 board only) -5 AI10 -6 Ret
AI11	J11-7 +5vdc (-001 board only) -8 AI11 -9 Ret
AI12	J11-10 +5vdc (-001 board only) -11 AI12 -12 Ret
AI13	J11-13 +5Vdc (-001 board only) -14 AI13 -15 Ret
AI14	J11-16 +5Vdc (-001 board only) -17 AI14 -18 Ret
AI15	J11-19 +5Vdc (-001 board only) -20 AI15 -21 Ret
AI16	J11-22 +5Vdc (001 board only) -23 AI16 -24 Ret

ANALOG OUTPUTS

There are 5 each analog outputs on the -000 board and 7 each on the -001 board. FIG 65G is a detail of this input and is representative of all these inputs. Each output can provide either a 0-10Vdc output (between terminals 2 & 3) or 4-20mA output (between terminals 1 & 3).

<u>OUTPUT</u>	<u>CONNECTION</u>
AO1	TB1-1 4-20mA -2 0-10V -3 Ret
AO2	TB2-1 4-20mA -2 0-10V -3 Ret
AO3	TB3-1 4-20mA -2 0-10V -3 Ret
AO4	TB4-1 4-20mA -2 0-10V -3 Ret
AO5	TB5-1 4-20mA -2 0-10V -3 Ret
AO6	TB6-1 4-20mA (-001 board only) -2 0-10V -3 Ret
AO7	TB7-1 4-20mA (-001 board only) -2 0-10V -3 Ret

ANALOG OUTPUTS

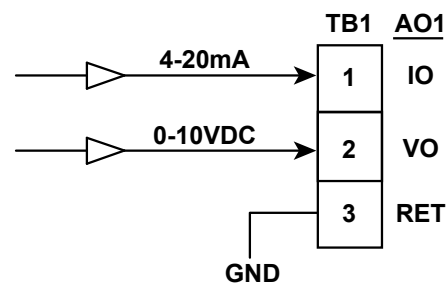

FIG. 65G – ANALOG OUTPUTS

LD14236

AUTO DETECTION

Earlier vintage chillers use Analog I/O Board 371-02514-000 for the Hot Gas Bypass feature. This board also connects to the COM3 Serial Port (J12). Since this board uses different protocol than the 031-02895-xxx board, the microboard must know which board is present in order to be able to communicate with it.

The microboard determines which board is present by the features that are enabled:

- If Heat Recovery and/or or Head Pressure control is enabled, it knows the 031-02895-xxx board is present and only the 031-02895-xxx board is polled.
- If only Hot Gas Bypass is enabled, the microboard automatically determines which board is present. At boot-up, the microboard alternates between polling the 031-02895-xxx board and the 371-02514-000 Board. Once a valid response is received from one of these two boards, the communications will continue to only poll that board type.

DIAGNOSTIC SCREEN

The Diagnostic Screen (FIG. 74), accessible from the MAIN DIAGNOSTICS Screen, is used to analyze the analog and digital inputs and outputs. It is also used to manually control the digital outputs and set analog output voltages.

There are two versions of this screen available as follows:

Service Access level

The voltage value of each analog input at the board input terminals/pins, as interpreted by the I/O Board and transmitted to the Microboard, is displayed as ANLOG INPUTS.

The voltage value sent from the Microboard to the I/O Board for each Analog Output is displayed as ANALOG OUTPUTS.

The on/off status of the Digital Inputs and Digital Outputs are indicated with an LED. It is illuminated when the input or output is on; extinguished when it is off.

Modbus communication error counters are displayed as follows, along with the ability to reset the counters:

- ID faults – This is the number of packets received with an incorrect slave ID
- Checksum errors – This is the number of checksum errors encountered in communication
- Error packets – This is the number of error packets received
- Timeout Faults – This is the number of timeout faults encountered. A timeout is registered when no valid response is received for a poll within 2 seconds.

Service Access Level plus Microboard DIP Switch 1-3 to ON (FIG. 7A)

In addition to the same displays above, the following can be performed.

The digital outputs can be individually turned on or off. Use the SELECT DIGITAL OUTPUTS key to select the desired output, then use the ENABLE and DISABLE keys to turn it on or off.

The Analog Outputs can be individually set to a desired voltage value. Use the SELECT ANALOG OUTPUT key to select the desired output, then use the numeric keypad keys to set it to the desired value.

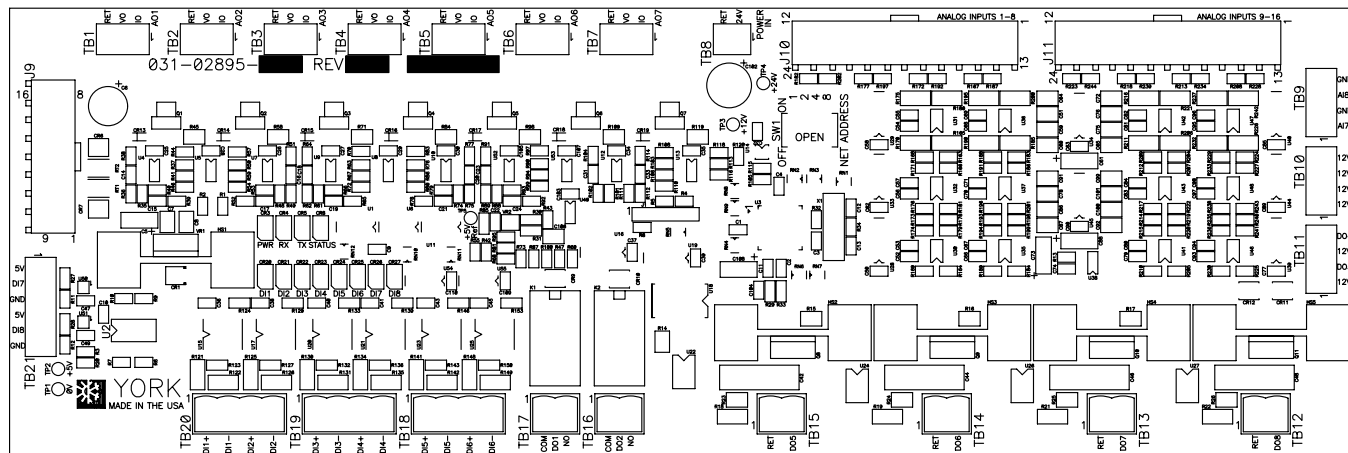

FIG. 66 – I/O BOARD (031-02895-xxx)

LD14349

SECTION 24 HEAT RECOVERY

(Software Version C.OPT.01.21.307 and later)

This option uses two tube bundles in the condenser. The lower bundle is the standard condenser bundle and is piped to the cooling tower water source. The upper tube bundle is used to recover waste heat rejection for use in a closed loop heating circuit. Chillers equipped with this feature are also equipped with the Hot Gas Bypass feature.

On a heat recovery chiller, the chiller primary control remains the cooling load. So, the compressor capacity is still functioning according to the leaving chilled water temperature set point.

The desired hot water temperature leaving the heating bundles is obtained by regulating the heat rejection through the standard lower tube bundle (sourced by cooling tower or other water circuit). This is done by controlling the temperature of the Return Condenser Water Temperature (by tower bypass circuit to elevate the temperature of the return condenser water) or varying the condenser water flow. This control can be performed by the Optiview Control Center or an external controller. If the Optiview Control Center is used to perform this control, The Heat Recovery Control Valve is modulated to control the Leaving Heating Condenser Water Temperature to the Hot Water Setpoint. The control output to the valve is Direct Acting (when the Leaving Heating Condenser Water Temperature rises above the Hot Water Setpoint, the valve is driven more open to provide greater cooling to the standard lower tube bundle).

The heat recovery bundle is provided with a Leaving Heating Condenser Water Thermistor, Return Heating Condenser Water Thermistor and a Heating Condenser Water Flow Switch. The heat recovery circuit control is only active when the flow sensor indicates flow.

If the chiller is equipped for Heat Recovery, the feature must be ENABLED on the SETUP Screen. Otherwise, it must be DISABLED. Once enabled, the HEAT RECOVERY Screen is available from the CONDENSER Screen. All of the Heat Recovery parameters are displayed on this screen. If Head Pressure Control is also enabled, the Head Pressure parameters appear on the Heat Recovery Screen (there is no separate Head Pressure Control Screen in this configuration).

Inputs/Outputs (ref FIG. 67)

The I/O used for the Heat Recovery feature is:

- Leaving Heating Condenser Water Temperature Thermistor input
- Return Heating Condenser Water Temperature Thermistor input
- Heating Condenser Water Flow Switch input (paddle or thermal type)
- Heat Recovery Control Valve output (0-10Vdc or 4-20mA)

The above are interfaced to the LTC I/O Board 031-02895-000 as shown in FIG. 67 (the thermal flow switch connects directly to the microboard). The operation of this I/O Board is explained in Section 23. The microboard communicates with this board using RS-485 Modbus serial communications. The microboard reads the Heating Condenser Water Temperature Thermistors and the Flow Switch status via this interface. It also drives the Heat Recovery Control Valve via a 0-10vdc or 4-20mA output as described below.

Use figure 63A to convert the Heating Condenser Thermistors voltage output to a (°F) temperature value.

Control

If the Optiview Control Center is used to control the Heat Recovery Valve, then the Hot Water Control Setpoint on the Heat Recovery Screen must be ENABLED. If Disabled, only the heat recovery inputs are displayed. When enabled, all of the control parameters are displayed on this screen as described below.

Setpoints:

- Hot Water Control Setpoint – (Extended temp range = 65.0°F to 125.0°F; default 95.0)(Standard temp range= 65.0°F to 112°F; default 95.0) Sets the temperature that the Leaving Heating Condenser Water Temperature will be controlled to. Displayed as Active Hot Water Setpoint.
- Control Valve Output Settings:
 - a.) TYPE – Makes the control signal to the Heat Recovery Control Valve either 0-10vdc or 4-10mA (default 0-10Vdc)

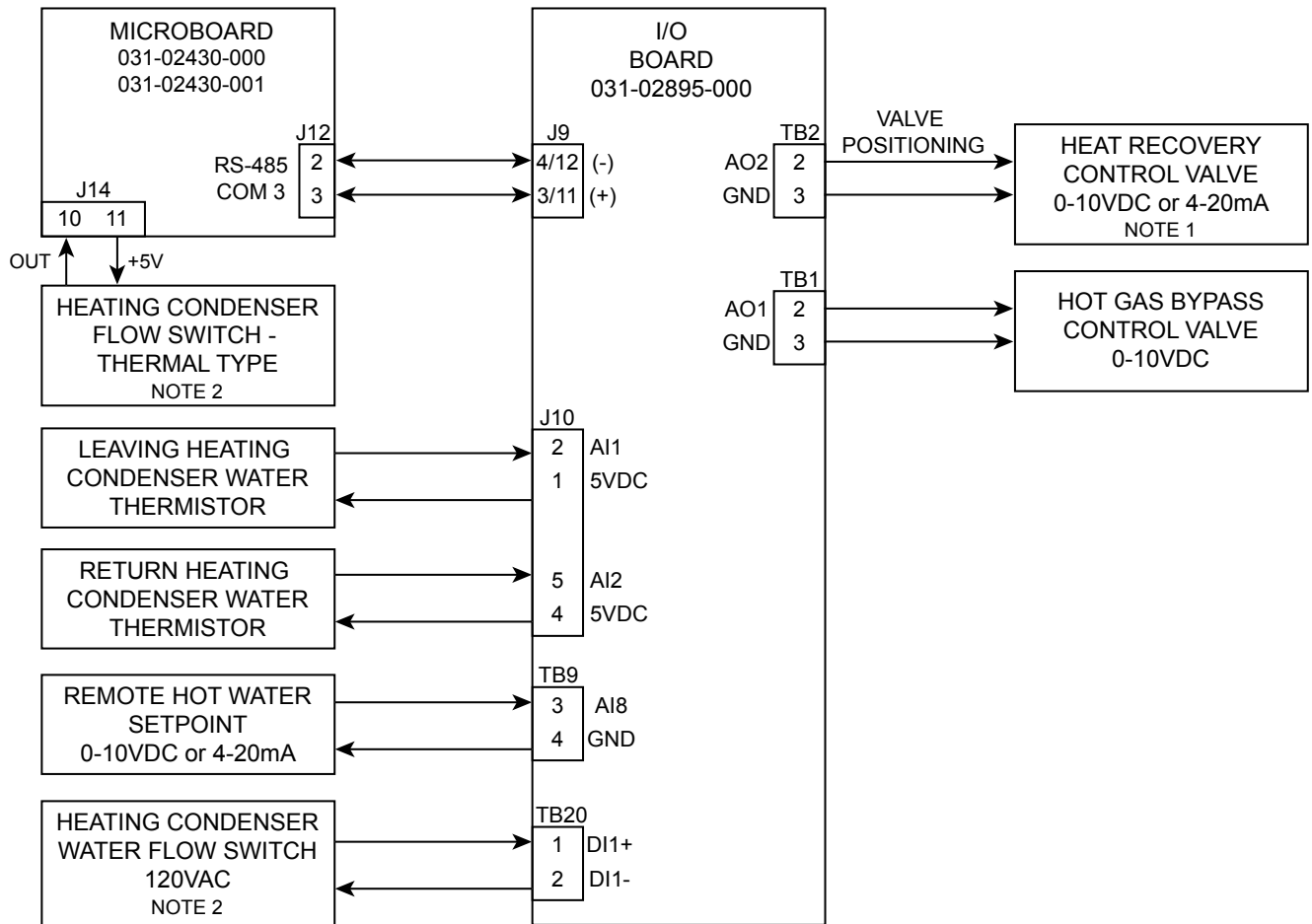

NOTES:

1. If Head Pressure Control is ENABLED and Hot Water Control is DISABLED or if Hot Water Control is ENABLED but there is NO water flow in the heating condenser, valve control will automatically switch over to the Head Pressure Control.
2. The chiller could be equipped with either paddle/differential pressure (120VAC) type or Thermal Type (+5VDC) flow switches. Each Type must be connected as shown.

FIG. 67 – HEAT RECOVERY BLOCK DIAGRAM

LD14238

- b.) PID OUTPUT – Makes the control signal to the Heat Recovery Control Valve either Direct or Reverse acting (default Direct). Set to Direct for this application.
- c.) SET – Is used to manually set the Heat Recovery Control Valve to any position between 0.0% and 100%
- d.) AUTO – Returns the Heat Recovery Control Valve to automatic control mode (default Auto)
- Hot Water Control – Sets the proportional gain of the control:
 - a.) P- Sets the proportional gain of the control over the range of 0.00 to 5.00(default 2.00)
 - b.) I – Sets the integral gain of the control over the range of 0.0 to 5.00 (default 2.00)
 - c.) D – Sets the derivative gain of the control over the range of 0.0 to 5.00 (default 0.00)
- Remote Input Type – Configures the LTC I/O Board input (TB9-3/4) to accept either a 0-10Vdc or 4-20mA input signal type for the Remote Hot Water Setpoint input.

When Hot Water Control is active, the Control Valve Output is modulated by a direct acting PID control. The inputs to the PID control are the Leaving Heating Condenser Water Temperature and the Hot Water Setpoint (the ACTIVE HOT WATER Setpoint displays the setpoint in use). The PID control error is defined as (Hot Water Setpoint – Leaving Heating Condenser Water Temperature). The PID control's proportional, integral and derivative gains are programmable using the CHANGE SETPOINTS key. The Control Valve position is displayed as 0.0% to 100% in the box labeled CONTROL VALVE OUTPUT. The control output to the valve is Direct Acting (when the Leaving Heating Condenser Water Temperature rises above the Hot Water Setpoint, the valve is driven more open to provide greater cooling to the standard lower tube bundle). The following diagram shows the PID controller.

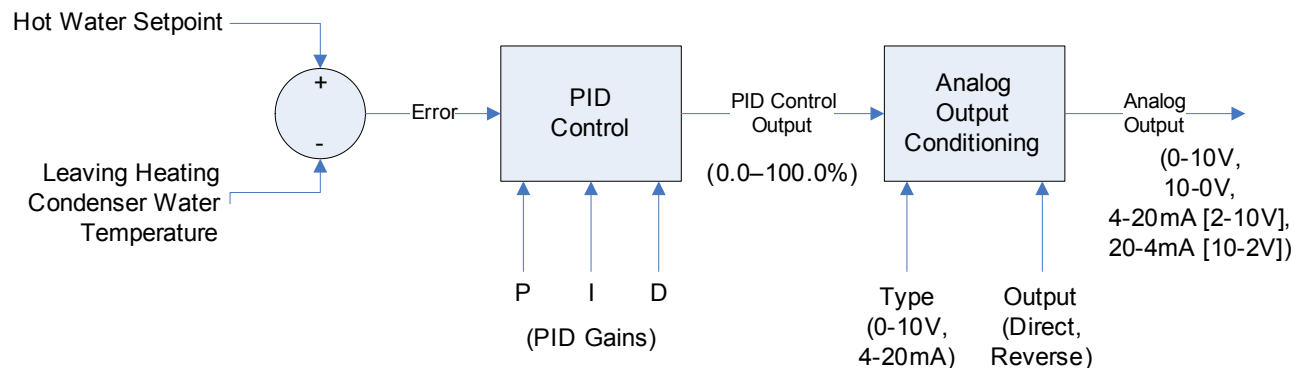

FIG. 68 – PID CONTROLLER DIAGRAM

The Control Valve Output Settings keys are used to configure the output signal to the Heat recovery Control Valve. The TYPE setpoint is used to make the control signal either 0-10Vdc or 4-20mA. The AUTO Setpoint is used to place the control in automatic mode. The SET Setpoint places the valve control in manual. It is used to manually position the control valve at any position between 0.0% and 100%. The Control Valve Control Mode shall be reset to Auto upon logging out of Service Level Access. The CONTROL VAVE CONTROL MODE data box displays the operating mode as “Manual” or “Auto” as appropriate.

The PID OUTPUT setpoint is used to configure the signal to the Control Valve to be DIRECT or REVERSE acting (default DIRECT). In this application, it should be set to DIRECT. The output for each setting is per the following table:

Control Valve Output Type	PID Output	PID Control 0% Output	PID Control 100% Output
0-10V	Direct	0V	10V
0-10V	Reverse	10V	0V
4-20mA	Direct	4mA (2V)	20mA (10V)
4-20mA	Reverse	20mA (10V)	4mA (2V)

If the chiller is equipped with both Heat Recovery and Head Pressure Control (see Section 25) and both are enabled, there is not a Control Valve for each feature. Rather, there is one common valve that is either performing Hot Water Control for Heat Recovery or it is performing Head Pressure Control. It will not be performing control for both features at the same time. Normally, it will be performing Hot Water Control until certain operating conditions cause it to switch over to Head Pressure Control. The PID CONTROL MODE displays which feature is controlling the valve at any given time. When performing Hot Water Control, “Hot Water” is displayed. When performing Head Pressure Control, “Head Pressure” is displayed. There are also conditions under which it not controlling either feature, in which case “Inactive” is displayed and the valve is set to 0% position. Which feature is controlling the valve at any instant and when it is inactive is determined by operating conditions as shown in the following flow chart.

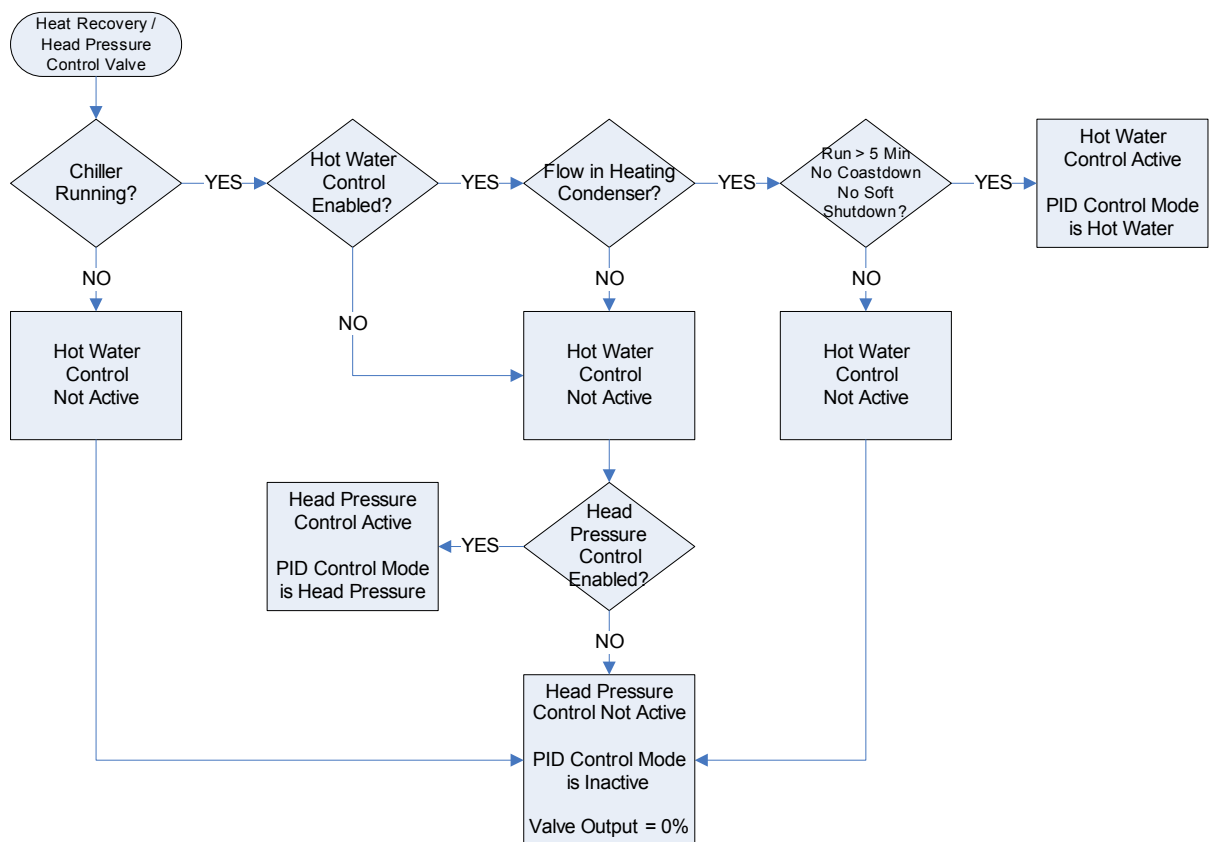

FIG. 69 – HEAT RECOVERY FLOW DIAGRAM

Remote Hot Water Setpoint

The Hot Water Setpoint can be remotely changed based on the chiller's Control Source setting. The Active Hot Water Setpoint will contain the actual setpoint being used for Hot Water Control. The following table shows what setpoint is used based on the Control Source.

Active Hot Water Setpoint	Control Source	Input	Description
Hot Water Setpoint	Local and Digital	Heat Recovery Screen	Locally programmed value
Remote Hot Water Setpoint	ISN	YorkTalk III Comms	Remote value via communications (GPIC List)
Remote Hot Water Setpoint Offset	Analog	Analog Input	Offset added to local Hot Water Setpoint 0V = -0°F offset, 10V = -20°F offset 4mA = -0°F offset, 20mA = -20°F offset

The allowable range for the Active Hot Water Setpoint is the same as the Local Hot Water Setpoint. If a remote value is received that is greater than the maximum, the active setpoint shall be set to the maximum. If a remote value is received that is less than the minimum, the active setpoint shall be set to the minimum. The Remote Hot Water Setpoint Input Type selects the type of input signal to be used (0-10V or 4-20mA) when the Control Source is set to Analog.

The REMOTE INPUT TYPE setpoint is used to configure the LTC I/O Board input TB9-3/4 to accept either a 0-10Vdc or 4-20mA input for the Remote Setpoint input. This setpoint must be set to the same value for the actual input applied. Otherwise, the remote setpoint will not be interpreted correctly. The ACTIVE HOT WATER SETPOINT data box displays the remote setpoint that is in effect.

Condenser Flow Switch Open Fault

The "Condenser-Flow Switch Open" Cycling Shutdown is changed when Heat Recovery is enabled. It shall shut the unit down only if both the Condenser Flow Switch and the Heating Condenser Flow Switch are open using the same timing as in the current logic. If either flow switch is closed, the chiller will not shut down.

SECTION 25

HEAD PRESSURE CONTROL

(Software Version C.OPT.01.21.307 and later)

YK Chillers are capable of operation within a wide range of condenser water temperatures. However, a minimum condenser water temperature, as specified in the Engineering Guide, is required to maintain sufficient pressure differential (head) between the condenser and evaporator for proper oil and refrigerant management in the chiller.

Should colder condenser water temperatures be anticipated at the cooling source, a field mounted facility control means may be provided to ensure adequate head pressure exists. The preferred means would be a cooling tower bypass circuit that maintains a constant flow rate through the condenser, since this would maintain adequate tube velocity in the condenser, while regulating the return cooling water to the condenser. However, a two-way condenser water throttling valve, a variable speed cooling tower pump, or tower fan control circuit might also be employed.

The head pressure control function provides an analog output control signal from the Optiview Control Center that responds to the programmed Head Pressure (condenser pressure minus evaporator pressure) Setpoint. The output is direct acting (as the Head Pressure increases above the setpoint, the valve is driven more open to provide less tower bypass or more flow through the condenser).

If the chiller is equipped for Head Pressure Control, the feature must be ENABLED on the SETUP Screen using the Head Pressure Control Setpoint. Otherwise it must be DISABLED. Once enabled, the Head Pressure Control Screen is available from the Condenser Screen. All of the Head Pressure Control parameters are displayed on this screen. If Heat Recovery is also Enabled, the Head Pressure parameters appear on the Heat Recovery Screen (there is no separate Head Pressure Control Screen in this configuration).

Inputs/Outputs (ref FIG. 70)

The I/O used for Head Pressure Control feature is:

- Evaporator Transducer
- Condenser Transducer
- Head Pressure Control Valve output (0-10Vdc or 4-20mA)

The Evaporator Transducer and Condenser Transducer are connected to the Microboard as shown in FIG. 70. This provides the head pressure (condenser minus evaporator) to the Microboard. The Head Pressure Control Valve is driven from the LTC I/O Board 031-02895-000. The operation of this board is explained in Section 23. The Microboard communicates with this board using RS-485 Modbus serial communications. It sends the valve positioning command, via this serial link,

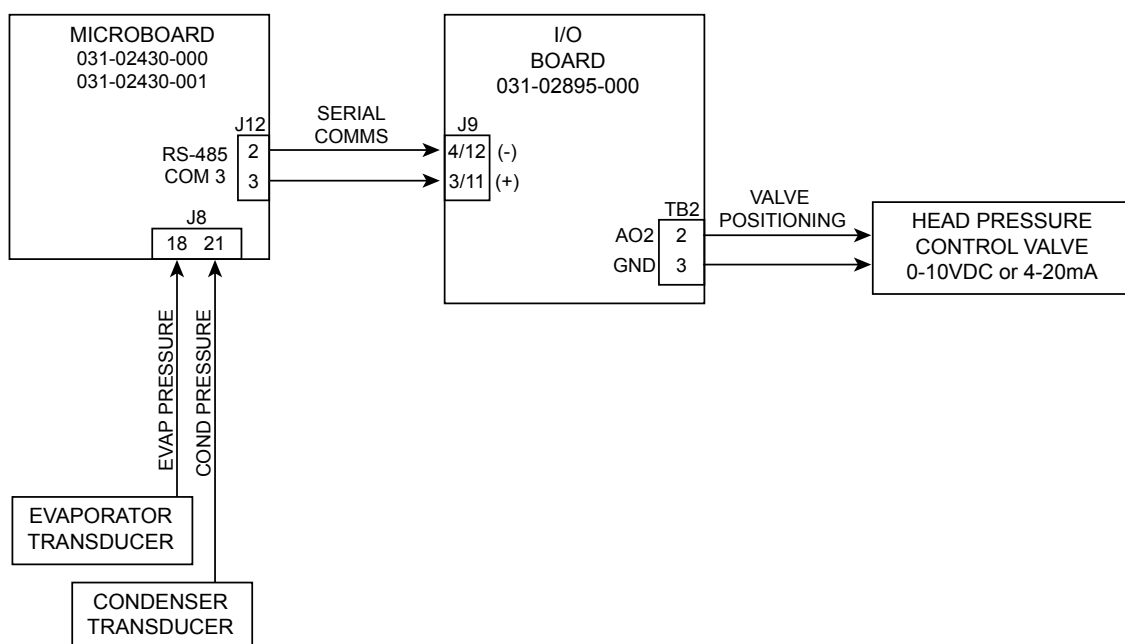

FIG. 70 – HEAD PRESSURE CONTROL BLOCK DIAGRAM

LD14237

to the I/O Board where it is converted to a 0-10Vdc or 4-20mA positioning signal that is applied to the valve as described below.

CONTROL

When Head Pressure Control is enabled, all the following programmable settings and applicable parameters are available on the Head Pressure Control Screen (or Heat Recovery Screen, if Heat Recovery is Enabled).

Setpoints:

- Head Pressure Setpoint (15.0 PSID to 60.0 PSID; default 23 PSID) - Sets the Head Pressure that the control will control to. Value entered is displayed as Head Pressure Setpoint.
- Control Valve Output Settings:
 - a.) TYPE – Makes the control signal to the Head Pressure Control Valve either 0-10vdc or 4-10mA (default 0-10Vdc)
 - b.) PID OUTPUT – Makes the control signal to the Head Pressure Control Valve either Direct or Reverse acting (default Direct). Set to Direct for this application.
 - c.) SET – Is used to manually set the Head Pressure Control Valve to any position between 0.0% and 100%
 - d.) AUTO – Returns the Head Pressure Control Valve to automatic control mode (default Auto)

- Head Pressure Control – Sets the proportional gain of the control:
 - a.) P- Sets the proportional gain of the control over the range of 0.00 to 5.00(default 2.00)
 - b.) I– Sets the integral gain of the control over the range of 0.0 to 5.00 (default 2.00)
 - c.) D – Sets the derivative gain of the control over the range of 0.0 to 5.00 (default 0.00)

When Head Pressure Control is enabled, the Control Valve Output is modulated by a direct acting PID control. The inputs to the PID control are the chiller Head Pressure (Condenser Pressure – Evaporator Pressure) and the Head Pressure Setpoint. The PID control error is defined as Head Pressure Setpoint – Head Pressure. The PID control’s proportional, integral and derivative gains are programmable using the CHANGE SETPOINTS key. The Control Valve position is displayed as 0.0% to 100% in the box labeled CONTROL VALVE OUTPUT. The control output to the valve is direct acting (as the Head Pressure increases above the setpoint, the valve is driven more open to provide less tower bypass or more flow through the condenser). The following diagram shows the PID controller:

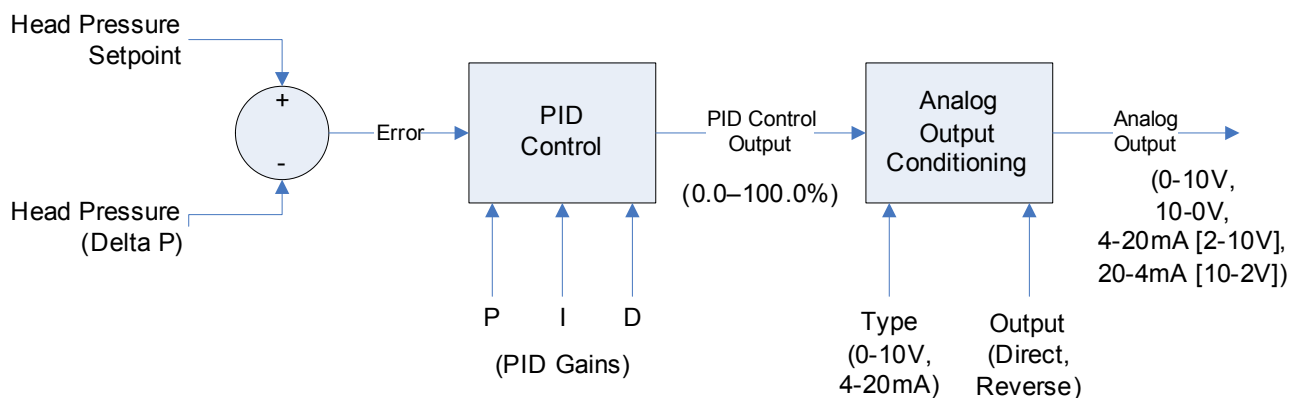

FIG. 71 – HEAD PRESSURE CONTROL FLOW DIAGRAM

The Control Valve Output Settings keys are used to configure the output signal to the Heat recovery Control Valve. The TYPE setpoint is used to make the control signal either 0-10Vdc or 4-20mA.

The AUTO Setpoint is used to place the control in automatic mode. The SET Setpoint places the valve control in manual. It is used to manually position the control valve at any position between 0.0% and 100%. The Control Valve Control Mode shall be reset to Auto upon logging out of Service Level Access. The CONTROL VAVE CONTROL MODE data box displays the operating mode as “Manual” or “Auto” as appropriate.

The PID OUTPUT setpoint is used to configure the signal to the Control Valve to be DIRECT or REVERSE acting (default DIRECT). In this application, it should be set to DIRECT. The output for each setting is per the following table:

Control Valve Output Type	PID Output	PID Control 0% Output	PID Control 100% Output
0-10V	Direct	0V	10V
0-10V	Reverse	10V	0V
4-20mA	Direct	4mA (2V)	20mA (10V)
4-20mA	Reverse	20mA (10V)	4mA (2V)

Operation when Equipped with Both Heat Recovery and Head Pressure Control

If the chiller is equipped with both Heat Recovery and Head Pressure Control and both are enabled, there is no separate Head Pressure Control Screen. All Head Pressure Control Parameters and setpoints are shown on the Heat Recovery Screen. Also, there is not a Control Valve for each feature. Rather, there is one common valve that is either performing Hot Water Control for Heat Recovery or Head Pressure Control. It will not be performing control for both features at the same time. Normally, it would be performing Hot water Control until certain operating conditions cause it to switch over to Head Pressure Control. The PID CONTROL MODE displays which feature is controlling the valve at any given time. When performing Hot Water Control, “Hot Water” is displayed. When performing Head Pressure Control, “Head Pressure” is displayed. There are also conditions under which it is not controlling either feature, in which case “Inactive” is displayed and the valve is set to 0% position. Which feature is controlling the valve at any given instant and when it is inactive is determined by operating conditions as shown in flow chart in Heat Recovery Section 24.

Remote Head Pressure Setpoint

This setpoint cannot be set from a remote input.

SECTION 26 QUICK START

(Software Version C.OPT.01.21.307 and later)

The Quick Start feature is useful in data center and process control applications where it is desirable to re-establish cooling as fast as possible after a shutdown or power failure. This feature, when enabled, allows quicker starts and restarts than normal control. It does this by reducing the time cycle for chiller restart and once running, loading the chiller as fast as possible. After the chiller is running and has met a specified setpoint or a specified period of time has elapsed, control returns to normal.

In order to use this feature, the chiller must be equipped with a Variable Speed Drive (in Modbus Protocol Configuration) or a Medium Voltage Variable Speed Drive. The low inrush current of a VSD allows more starts per hour and allows the chiller to start with a more open vane position.

Although not required, the Hot Gas Bypass option is recommended, as it will allow the chiller to startup more smoothly with less chance of surging.

Quick Start feature has two different start modes:

- **Quick Restart** – When a chiller shutdowns, if certain conditions are met at the completion of Coastdown (and within 30 seconds thereafter), the VSD is started immediately with no Prelube. The vanes are given a constant open pulse and after the VSD achieves its start frequency, the speed ramp rate is faster than with normal control.
- **Quick Normal Start** – If the conditions for a Quick Restart are not met, the next time the chiller is started, it has a prelube period just like a normal start, however the vanes will begin to open at the beginning of Prelube, instead of waiting until System Run. At the completion of Prelube, the VSD is started and after the VSD achieves its Start Frequency, the speed ramp rate is faster than with normal control.

In order to take full advantage of the Quick Start feature after a power failure, the Optiview Control Center and VSD control power (except for the Trigger Board) must be on a UPS. This prevents a reboot of both on a power failure and keep communications between them active throughout the utility power failure. This provides the fastest possible ability to start or restart after generator or utility power is restored.

This feature can only be enabled if the Motor Drive Type setpoint is set to MV VSD or VSD (and the Motor Communications Protocol Setpoint is set to MODBUS). It requires an ADMIN password to change. When logged in at ADMIN access level, a QUICK START key will appear on the SETPOINTS Screen. Pressing this key will navigate to the QUICK START Screen where the QUICK START MODE Setpoint is used to enable/disable this feature as explained in the Setpoints section below.

Once enabled, all setpoints and parameters related to this feature are displayed on the QUICK START Screen, accessible from the SETPOINTS Screen when logged in at Service access level.

SETPOINTS

The following setpoints pertaining to this feature are listed on the Quick Start Screen. Use the CHANGE SETPOINTS key and UP/DN Arrow keys to place a green box around the desired setpoint to be changed. Then press the CHECKMARK key. A box will appear with the allowable values. Enter/Select the desired value and press the CHECKMARK key.

- **Quick Start Mode** (Enabled, Disabled; default Disabled) -This setpoint is used to Enable and Disable the Quick Start feature. It can only be Enabled when the Motor Drive Type Setpoint is set to VSD and the Motor Communications Protocol is set to Modbus. Or, the Motor Drive Type Setpoint is set to MVVSD. The default is DISABLED.

Quick Start can only be enabled using an ADMIN password. When logged in at ADMIN access level, a QUICK START key will appear on the SETPOINTS Screen. Pressing this key will navigate to the QUICK START Screen where this setpoint is used to enable/disable the feature.

Quick Start can be Disabled when logged in at Service access level. However, once Disabled, it requires an ADMIN password to enable it again, as explained above.

Quick Start Mode will be automatically disabled when any of the following occur: The Motor Drive Type is changed to something other than VSD or MVVSD or the Motor Communications Protocol is changed to YORK

- **Quick Pulldown Setpoint Offset** (0°F to 10°F; default 5°F) - This setpoint sets the Leaving Chilled Liquid Temperature at which the control transitions from Quick Start mode to normal operation. It is entered in the form of an offset above the active Leaving Chilled Liquid Temperature (LCHLT) Setpoint. Once the leaving chilled liquid temperature falls below the Active LCHLT Setpoint + Quick Pulldown Setpoint Offset, PRV (Quick Restart) and speed control (Quick Restart and Quick Normal Start) revert to normal automatic control. Lower values of this offset result in faster pulldown times but can result in overshoot of the LCHLT setpoint. Setting the value to its minimum of 0 results in the fastest pulldown time but nearly always results in setpoint overshoot. Depending upon how close the Low Chilled Liquid Temperature shutdown threshold is to the LCHLT setpoint, this could result in a Low Chilled Liquid Temperature cycling shutdown.

The leaving chilled liquid temperature and setpoint is shown on the Quick Start Screen for reference. This setpoint sets one of the two setpoints that determine when the control transitions from Quick Start mode to normal operation. The other is the Pulldown Override Time below.

- **Pulldown Override Time** (0 min to 15 min; default 10 min)- This setpoint is the length of time the PRV is held open (Quick restart) and the ACC speed (Quick Restart and Quick Normal Start) is increased on startup if the Quick Pulldown Setpoint Offset is not reached. This could be due to hitting current limit during the pulldown. If the Quick Pulldown Setpoint Offset is not reached in the Pulldown Override Time, PRV and ACC speed control will revert back to normal automatic control.
- **VSD Start Frequency** (60Hz units with quick start enabled = 30Hz to 45Hz; default 45Hz)(50Hz = 25Hz to 37.5Hz; default 37.5Hz) - This setpoint is the same as shown on the ACC Details Screen. It can be programmed on either the ACC Screen or the Quick Start Screen. It sets the VSD start frequency from which the speed will ramp from.
- **ACC Mapping Enable** (0.5°F to 4.0°F; default 1.0°F) - This is the same setpoint as shown on the ACC Details Screen. It can be programmed on either the ACC Screen or the Quick Start Screen. It sets the Delta T needed to be met to enable surge mapping and speed reduction initially on startup.
- **Quick Ramp Current Threshold** (20% to 80% FLA; default 50%) - This setpoint sets the motor current threshold where the VSD speed command ramp rate changes. At or below this threshold the speed command ramp is 4X of standard control. Over this threshold, the ramp rate is 2X of standard control until it hits the standard current limiting over 80% FLA. Higher current thresholds can result in faster pulldown times. However, setting this value too high can result in slower pulldown times due to hitting the current limit sooner on pulldown.
- **Coastdown Time** – When Quick Start is enabled, the minimum programmable coastdown time for this setpoint is lowered as follows: Q Compressors from 150 seconds to 60 seconds; J7 and K7 Compressors from 240 to 150 seconds; all other Compressors from 150 to 90 seconds.

OPERATION

When Quick Start Mode is enabled, there are several operational enhancements common to both Quick Restart and Quick Normal Start to decrease time between starts as follows:

- The Coastdown time can be shortened using the COASTDOWN TIME setpoint.
- The “Oil - Low Temperature Differential” threshold is decreased to 10°F (from 30 or 40, depending on conditions) for 15 minutes after the last shutdown (the timer begins when the run signal is removed).
- The Oil Heater is controlled to maintain a minimum oil temperature, ensuring it is warm enough to allow a restart as follows: While the oil pump is running, if oil temp < 100°F, the oil heater is turned ON until it reaches > 105°F whereupon it is turned OFF. In order for this function to operate, a wiring change is required to the oil heater wiring as described below.
- The Hot Gas Bypass Valve is positioned to the Maximum Open Setpoint value during Soft Shutdown, Coastdown and while not running. It returns to normal control (closed) when the Run signal is enabled.

- The PRV open/close status switch does not have to be closed in order to start.

Quick Restart

Whenever the chiller shutdown, for whatever reason, the following will occur in preparation for a Quick Restart: During the Coastdown period and for 30 seconds after the end of Coastdown, the PRV and Variable Orifice positions are held in place, a precharge command is sent to the VSD, the chilled Liquid Pump contacts TB2-44/45 are maintained closed and the Oil Pump continues to run (target oil pressure 45PSID).

When Coastdown has completed (and for 30 seconds thereafter), if the following conditions are met, a run command is sent to the VSD and the Quick Pulldown begins. No Prelube occurs.

- Oil Pressure > 25PSID
- VSD has completed Precharge
- Chiller start signal (local or remote) is present
- No faults/inhibits present
- Chilled liquid flow switch is closed

Since there is no Prelube, the Auto-zeroing that normally occurs between the Oil Pressure Transducers during Prelube, does not occur. The offset calculation from the last Quick Normal Start is used. The level control preset (for the duration set by the Valve Preset Time setpoint) does not take place.

When the run command is sent to the VSD, the chiller enters System Run and the Quick Pulldown begins. The “Quick Pulldown In Effect” LED on the Quick Start screen illuminates while the Quick Pulldown is in effect. The Level Control begins ramping immediately, rather than waiting for 3 minutes after entering System Run, as it does in normal operation. The Oil Pump continues to use the Target Oil Pressure of 45 PSID for the first 15 seconds into run, then reverts to the programmed setpoint value. The speed command programmed as the VSD START FREQUENCY setpoint is sent to the VSD. The speed will ramp up to maximum frequency from this point at 4X the standard control until it reaches the current set as the QUICK RAMP CURRENT THRESHOLD setpoint (20-80% FLA), whereupon it ramps at 2X standard control until it reaches the standard current limiting over 80% FLA, whereupon it ramps at standard rate. A continuous open signal is applied to the PRV.

The continuous open signal to the PRV and the quick VSD speed ramping will continue until either the Leaving Chilled Liquid Temperature decreases to the temperature set by the QUICK PULLDOWN SETPOINT OFFSET (0-10°F) setpoint or the PULLDOWN OVERRIDE TIME (0-15 min) setpoint has elapsed, whereupon all VSD speed control and PRV control returns to standard.

In order for a Quick Restart to be performed after a power failure, the power failure duration must be no longer than about 60 seconds. Data centers can generally guarantee stable generator power to be available 15 seconds or less following a power failure. Longer power failures will result in a Quick Start (see below) rather than a Quick Restart.

If the criteria for a Quick Restart above is not met within 30 seconds after coastdown has completed, the following control returns to standard control:

- Chilled Liquid Pump control returns to standard
- PRV control returns to standard
- Variable Orifice control returns to standard and is opened
- Oil Pump control is returned to standard and turns off

If a Quick Restart did not occur within 30 seconds of the end of Coastdown as described above, the next start that occurs will be a QUICK NORMAL START as described below.

Quick Normal Start

If a Quick restart does not occur within 30 seconds after the end of Coastdown as described above, the next start that occurs will be a Quick Normal Start. This is a start that uses a Prelube but loading is faster than normal.

During the Prelube, a continuous open signal is given to the PRV as soon as the oil pump run signal is enabled. This open signal will be sent until the Prelube is complete, whereupon PRV control returns to normal automatic control. The level Control and Oil Pump are controlled during Prelube and System Run as in normal operation. At the completion of Prelube, a run command is sent to the VSD, the chiller enters System Run and the Quick Pulldown begins. The “Quick Pulldown In Effect” LED on the Quick Start screen illuminates while the Quick Pulldown is in effect. The speed command programmed as the VSD START FREQUENCY setpoint is sent to the VSD. The speed will ramp up to maximum frequency from this point at 4X the standard

control until it reaches the current set as the QUICK RAMP CURRENT THRESHOLD setpoint (20-80% FLA), whereupon it ramps at 2X standard control until it reaches the standard current limiting over 80% FLA, whereupon it ramps at standard rate to full speed. If at any time during this ramping to full speed, if the Leaving Chilled Liquid Temperature decreases to the temperature set by the QUICK PULLDOWN SETPOINT OFFSET (0-10°F) setpoint, the PULLDOWN OVERRIDE TIME (0-15 min) setpoint has elapsed (whichever occurs first) or the motor current is greater than 100% FLA, the Quick Pulldown terminates and all VSD speed control returns to normal control.

Summary

The following table compares a Normal Start, Quick Normal Start and a Quick Restart. The Normal Start is that which has been the standard starting sequence and that which occurs when the Quick Start feature is disabled. This is a high level comparison and does not include all details of Quick Start Mode.

Normal Start (Standard Logic)	Quick Normal Start	Quick Restart
Minimum Coastdown Time 150 sec (Q Compressors) 240 sec(J7,K7 Compressors) 150 sec(all other Compressors)	Minimum Coastdown Time 60 sec (Q Compressors) 150 sec (J7, K7 Compressors) 90 sec (All other Compressors)	Minimum Coastdown Time 60 sec (Q Compressors) 150 sec (J7, K7 Compressors) 90 sec (All other Compressors)
Chiller Off PRV Closed Variable Orifice Opened Hot Gas Closed	Chiller Off PRV Closed Variable Orifice Opened Hot Gas Opened	Coastdown PRV Held (Open) Variable Orifice Held (Open) Hot Gas Opened
Prelube PRV Closed Variable Orifice Preset/Held Hot Gas Closed	Prelube PRV Opened Variable Orifice Preset/Held Hot Gas Opened	No Prelube
VSD Run Signal Enabled	VSD Run Signal Enabled	VSD Run Signal Enabled
PRV Controlled by Capacity Control Variable Orifice Preset/Held/Ramp VSD to Start Frequency Hot Gas Standard Control	PRV Controlled by Capacity Control Variable Orifice Preset/Held/Ramp VSD to Start Frequency Hot Gas Closed (Std Control)	PRV Given Constant Open Signal Variable Orifice Ramp VSD to Start Frequency Hot Gas Closed (Std Control)
Slow Ramp-up of Speed	Quick Ramp-up of Speed Speed Control Returns to Standard when LCHLT < Active LCHLT Setpoint + Quick Pulldown Setpoint Offset OR when Run Time > Pulldown Override Time	Quick Ramp-up of Speed PRV and Speed Control Return to Standard when LCHLT < Active LCHLT Setpoint + Quick Pulldown Setpoint Offset OR when Run Time > Pulldown Override Time

The following details how the individual functions are changed for Quick Restarts and Quick Normal Starts:

PRV Control

When Quick Start is enabled the PRV switch shall be ignored and does not have to be closed in order to start.

When Quick Start is enabled the PRV position will be held during coastdown and for 30 seconds after coastdown. If a quick restart is not initiated, the PRV control will return to standard during the not running state.

When Quick Start is enabled during normal startups, a continuous open signal will be sent to the PRV as soon as the oil pump run signal is enabled during prelube. This open signal will be sent to the PRV until prelube is complete and then PRV control will return to standard automatic.

When Quick Start is enabled during quick restarts, when the VSD is given a run signal, a continuous open signal will be sent to the PRV. The open signal will be sent to the vanes until LCHLT falls below the Quick Pulldown Setpoint Offset. Once this occurs, vane control shall revert to standard automatic control. Any kind of limiting (current, etc.) that would close the vanes will cause the vane control to revert back to standard automatic control and operate as it currently does. The PRV control will also be returned to normal if the Pulldown Override Time timer expires. This timer shall begin counting when the run signal is enabled.

VSD Control

When Quick Start is enabled, the VSD shall be sent a precharge command during coastdown and for 30 seconds after the end of coastdown.

Chilled Liquid Flow

Normal operation checks for chilled liquid flow beginning 5 seconds before the end of prelube. When Quick Start is enabled this check is done before restarting. If chilled liquid flow is not present by 30 seconds after the end of coastdown, the chiller will revert to standard quick normal start logic.

Chilled Liquid Pump Control

Normal operation turns the chilled liquid pump off at the end of coastdown. When Quick Start is enabled the chilled liquid pump is kept on for 30 seconds after coastdown is completed. If a quick restart is not initiated within 30 seconds of the end of coastdown, the pump is returned to normal control.

Condenser Level Control

When Quick Start is enabled the variable orifice position will be held in its current position during coastdown and for 30 seconds after the completion of coastdown. If a quick restart does not occur within 30 seconds of the end of coastdown the variable orifice control will revert to standard logic and open.

When Quick Start is enabled, if a quick restart does not occur within 30 seconds of the end of coastdown, set a "quick preset timer" to the programmed level control preset time. Count this timer down to 0. When the next normal quick start occurs, subtract the quick preset timer's current value from the preset time so the VO does not close too far and would essentially return to the last position it had held.

For normal operation a condenser level setpoint ramping algorithm is employed if the preset timer is set to zero or the chiller is running or if the preset timer is not zero and the chiller has been running for longer than 180 seconds. When Quick Start is enabled, for quick restarts only, the preset timer is ignored (no preset takes place) and the ramping algorithm is engaged immediately upon achieving a run state. For quick normal starts, level control works as it does currently.

Oil Sump Control

When Quick Start is enabled the pressure offset calibration (and the associated fault) is disabled for quick restarts only. The offset calculation from the last normal start shall be used. For a normal quick start the calibration and fault shall be active during prelube per the standard logic.

Normal operation checks for low oil pressure (< 25psid) beginning 5 seconds before the end of prelube. When Quick Start is enabled this check shall begin before restarting. If the chiller does not restart, this check will still be done on the next normal quick start using standard logic. If oil pressure is not present by 30 seconds after the end of coastdown, the chiller will revert to standard quick normal start logic but will not fault on low oil pressure. This fault is currently only active during prelube and run. It shall not cause a shutdown during coastdown or while not running.

Normal operation turns the oil pump off at the end of coastdown. When Quick Start is enabled the oil pump shall be kept running through coastdown until 30 seconds after the end of coastdown and into the restart. If a quick restart does not occur within 30 seconds of the end of coastdown, the oil pump shall return to standard control and turn off.

When Quick Start is enabled oil pressure pulldown is in effect (45 psid target) throughout coastdown, 30 seconds after coastdown is complete and 15 seconds into run if a quick restart is initiated.

The OIL - LOW TEMPERATURE DIFFERENTIAL cycling shutdown threshold is 30 or 40°F depending on conditions. When Quick Start is enabled this threshold is reduced to 10° F for 15 minutes after the last shutdown. This 15 minute time shall begin when the run signal is disabled.

With the Quick Start feature, the Oil Heater is controlled to maintain a minimum oil temperature, ensuring it is warm enough to allow a restart as follows:

While the oil pump is running, if oil temp < 100°F, turn the oil heater on and if oil temp > 105°F, turn the oil heater off. Otherwise, do not change existing logic. The Oil Heater wiring must be changed in order to make this function work properly. In standard configuration, the Oil heater does not have AC power available to it (from TB5-23) when the chiller run signal is enabled. Since the oil heater logic with Quick Start, as described above, requires the heater to be turned on while the Oil Pump is running (which is while the chiller run signal is enabled), the Oil Heater wiring must be changed to a terminal (TB5-22) that has AC power while the run signal is enabled as follows:

- Wire #23 on I/O Board TB5-23 must be relocated to TB5-22

Hot Gas Control

When Quick Start is enabled the hot gas output shall be set to the programmed Maximum Open value during all of the following conditions:

- During soft shutdown
- During coastdown
- While not running

Hot gas shall return to normal control (closed) when the run signal is enabled.

ACC Control

When the VSD has reached the VSD Start Frequency, the ACC speed command shall be ramped towards the maximum VSD frequency at a rate defined by the following table.

Initial Ramp Frequency Increase Rate	Conditions Required
0.1 Hz / 2 sec	Quick Start Disabled
0.1 Hz / 1 sec	Quick Start Enabled and Motor Current > Quick Ramp Disable
0.1 Hz / 0.5 sec	Quick Start Enabled and Motor Current ≤ Quick Ramp Disable

These rates will be reduced by the present ACC logic that limits the rate of speed increases when motor current > 80% FLA. This initial ramp will continue until one of the following Quick Ramp Disable conditions are present:

- Motor Current > 100% FLA
- LCHLT < Active LCHLT Setpoint + Quick Pulldown Setpoint Offset
- Command Frequency = Maximum VSD Frequency
- Run Time > Pulldown Override Time

Once one of these conditions is met, ACC control shall return to standard.

SECTION 27

SYSTEM CALIBRATION, SERVICE SETPOINTS AND RESET PROCEDURES

The chiller is supplied from the YORK Factory with all factory mounted components fully calibrated. The following procedures are used to verify these calibrations or calibrate a component after it has been field replaced.

Most of the following procedures require the Service Technician to be logged in at SERVICE Access Level (Access Code 1 3 8 0). However, others require the ADMIN (Administration) Access Level. The ADMIN Password changes daily and is valid for 1 calendar day only. This password is obtained by contacting the local YORK service office. When requesting this password, supply the “Controls” version of software (available on the DIAGNOSTIC Screen) and the calendar day on which you intend to use it.

Programmable Service Setpoints are used by the Program to control critical chiller operation. Also, some of these Setpoints can be used to enable or disable certain features. Although they have been entered at the YORK Factory, they can be changed by a field Service Technician. If the BRAM battery backed memory device is field replaced, all of the programmed setpoints will be lost. They will have to be re-entered into the new BRAM. Each of these Setpoints is described below. Programming procedures and OptiView Control Center Keypad operation required in the procedures below are detailed in YORK Operation Manual 160.54-O1. In general, the following procedure is used to enter Setpoints in this section:

1. Log in with the appropriate access level
2. Select the appropriate Display Screen.
3. Press the desired Setpoint key.

A dialog box appears, giving the minimum and maximum allowed values, Default value and present value. The dialog box can be canceled at any time by pressing the CANCEL (X) key.

4. If the dialog box begins with the word “Enter”, use the numeric keys to enter the desired value. Leading zeroes are not necessary. Press the • key to place a decimal point at the appropriate place. Pressing the ▲ key displays the Default value. Pressing the ▼ key clears the entry. The ◀ key is a backspace key and causes the entry point to move back one space. If the dialog box begins with “Select” or “Enable”, use the 13 pt ◀ and ▶ keys to select the desired value. The ◀ key decreases the value. The ▶ key increases the value.

5. Press the ENTER (✓) key. If the value is within range, it is accepted and the dialog box disappears. The chiller will begin to operate based on the new value. If out of range, the value is not accepted and a message describing why it is not acceptable is displayed momentarily.

Some Safety shutdowns will not permit the chiller to start until a special reset procedure is performed. These reset procedures require SERVICE access level and should not be performed by anyone other than a Service Technician. Each of these procedures is described below.

ELECTRO-MECHANICAL STARTER APPLICATIONS

If the Compressor Motor is driven by an Electro-Mechanical Starter, the OptiView Control Center is equipped with a CM-2 Current Module along with supporting components Diode Bridge (DB) and Calibration Resistors (RES), as described in a previous chapter of this book. The following procedures can be used to verify the calibration and perform the calibration if necessary. In addition to the calibration, Switch S1 and Potentiometer R16 have to be set appropriately on the CM-2 Module. If the CM-2 and/or RES are field replaced, field calibration is necessary.

CM-2 Settings:

1. Place Switch S1 in the appropriate position per the Starter type:
 - UP: Y-Delta or 57% Auto-transformer Starter
 - Down: All others
2. Calculate LRA/FLA ratio by dividing the Motor Lock Rotor Amps by the chiller Full Load Amps ($LRA/FLA = \text{ratio}$) and then adjust Potentiometer R16 to the ratio value.

Calibration Verification

1. At the Keypad, log in at SERVICE access level using access code 1 3 8 0.
2. Select MOTOR Screen and set Current Limit and Pulldown Demand Limit Setpoints to 100% FLA.
3. Run chiller. Read compressor motor current in Phase A, B, and C using a clamp-on Ammeter. Apply ammeter to highest Phase.
4. Select COMPRESSOR Screen.

5. Manually operate the Pre-rotation Vanes by pressing the OPEN and CLOSE Keypad keys as required to achieve a motor current equivalent to 100% FLA as indicated by the clamp-on Ammeter. The motor current value on the Display should indicate 100% FLA.
6. Manually operate the Pre-rotation Vanes by pressing the OPEN and CLOSE keys as required to achieve a motor current equivalent to 105% FLA as indicated by the clamp-on Ammeter. The 105% LED on the CM-2 Module should illuminate.

If the calibration verification does not perform as above, the following Calibration procedure will have to be performed:

Calibration:

1. At the Keypad, log in at SERVICE access level using access code 1 3 8 0.
2. Select MOTOR Screen and set Current Limit and Pull-down Demand Limit Setpoints to 100% FLA.
3. Select COMPRESSOR Screen.
4. Run chiller and read compressor motor current in Phase A, B and C using a clamp-on Ammeter. Apply Ammeter to highest Phase.
5. Manually operate the Pre-rotation Vanes by pressing the OPEN and CLOSE Keypad keys as required to achieve a motor current equivalent to 100% FLA as indicated by the clamp-on Ammeter. The voltage across Variable Resistors (RES) should be 0.90 to 1.05VDC. Measure this voltage by connecting a Voltmeter at CM-2 Board J1-2 (+) to J1-1(-). If necessary, adjust RES to achieve this value. FIGURE 38 contains formulas to calculate the resistance of RES required to achieve this voltage. Adjust both resistors equally such that the combined resistance equals the calculated value.
6. Manually operate the Pre-rotation Vanes by pressing the OPEN, CLOSE and HOLD Keypad keys, as required, to achieve a motor current equivalent to 105% FLA as indicated by the clamp-on Ammeter. Loosen locking nut on Potentiometer R8 on CM-2 and adjust until the CM-2 Module 105% LED illuminates. Counterclockwise increases signal level; Clockwise decreases signal level. Tighten locking nut.
7. Manually operate the Pre-rotation Vanes by pressing the OPEN and CLOSE Keypad keys, as required, to achieve a motor current equivalent to 100% FLA as indicated by the clamp-on Ammeter. Loosen locking nut on Potentiometer R34 on CM-2 and adjust until the motor current value on the Display indicates 100% FLA. Clockwise increases the signal level; Counterclockwise decreases the signal level. Tighten locking nut.

SOLID STATE STARTER APPLICATIONS

When the compressor motor is driven by a YORK Solid State Starter, one of three different Starters could be applied. Later production chillers are equipped with either the Style B Liquid Cooled Solid State Starter (LCSSS) or the Medium Voltage Solid State Starter (MVSSS). Earlier production vintage chillers are equipped with the Style “A” Solid State Starter. Refer to Section 11 for details of each of these starters. Use the following procedure to select the appropriate motor drive type, then select the appropriate procedure below for the starter type selected.

Motor Drive Type Selection:

- Microboard 031-1730-000: Position Program Jumpers JP37 and JP39 appropriately per Section 3, Table 1.
- Microboard 031-02430-000/001:
 1. Chiller must be stopped and RUN switch must be in Stop-Reset position.
 2. Select SETUP Screen.
 3. Press CHANGE SETTINGS key.
 4. A green box will appear around the first changeable setpoint. Use ▲ ▼ keys to place the box around MOTOR DRIVE TYPE setpoint.
 5. Press √ key. A dialog box will appear with the range of settings. Use ◀ ▶ keys to select “SSS-Mod A”, “SSS-Mod B” or “MV SSS”, as appropriate.
 6. Press ENTER (√) key.

MOD “B” LIQUID COOLED SOLID STATE STARTER

1. At the Keypad, log in at SERVICE Access level using Password 1 3 8 0.
2. Select MOTOR Screen.
3. Enter the following setpoints using the procedures below:

Full Load Amps:

This is the Full Load Amps (FLA) of the chiller as listed on the Sales Order Screen. The Microboard uses the programmed value to perform Current Limit functions and display compressor motor current in terms of %FLA.

1. Press FULL LOAD AMPS key.
2. Use numeric keypad keys to enter correct value.
3. Press ENTER (✓) key.

Start Current:

The Logic/Trigger Board will limit compressor motor current to this value during starting. The correct value is (0.45 x Delta Locked Rotor amps), as listed on the SALES ORDER Screen.

1. Press STARTING CURRENT key.
2. Use numeric keypad keys to enter correct value.
3. Press ENTER (✓) key.

Voltage Range:

This is the compressor motor AC power line application. Selections are 200-208, 220-240, 380, 400, 415, 440-480, 550-600 and Disabled. The Microboard uses the programmed value to determine the overvoltage and undervoltage shutdown thresholds for “LCSSS – HIGH SUPPLY LINE VOLTAGE” and “LCSSS – LOW SUPPLY LINE VOLTAGE” cycling shutdowns as described in Operation Manual 160.54-O1. If DISABLED is selected, the shutdown thresholds will be ignored. This check should not be arbitrarily disabled.

1. Press VOLTAGE RANGE key.
2. Use ◀ and ▶ keys to scroll to desired value.
3. Press ENTER (✓) key.

Open SCR Enable/Disable:

This allows the Open SCR safety check, performed by the Logic/Trigger Board, to be disabled. This must NEVER be disabled unless advised by the YORK factory.

1. Press OPEN SCR key.
2. Use ◀ and ▶ keys to select Enable or Disable.
3. Press ENTER (✓) key.

Kilowatt Hours (KWH) Reset:

This allows the KWH to be set to a desired starting value in the event the BRAM has to be field replaced. This must never be arbitrarily performed.

1. Press KWH RESET key.
2. Use numeric keypad keys to enter desired value.
3. Press ENTER (✓) key.

Motor Communications Protocol:

(Software version C.OPT.01.18.307 and later)

Allows the Service Technician to enable the appropriate serial communications port for communications with the Style B Liquid Cooled Solid State Starter (LCSSS). Early vintage Style B LCSSS communicate with the microboard using YORK protocol (COM 5 (J15)). Later vintage units (after mid 2008) use MODBUS protocol (COM 2 (J13)).

The protocol selection enables the appropriate communications port: YORK enables COM 5 (J15); MODBUS enables COM 2 (J13). Selection required is based on the hardware and interface that is present. Refer to SECTION 11 to determine which hardware/interface is present.

- YORK - Enables COM 5 (J15) serial port. Used when the microboard is interfaced to the LCSSS Logic/Trigger Board TB2.
- MODBUS - Enables COM 2 (J13) serial port. Microboard 031-02430-001 is required. Program Jumpers JP14 (BRAM size) and JP17 (COM 2 Serial Mode) must be configured per SECTION 3A, Table 3. Used when the microboard is interfaced to LCSSS Logic/Trigger Board 031-02505 (J14). Microboard can be equipped with either 32K BRAM (031-02431-000) or 128K BRAM (031-02565-000).

1. Chiller must be stopped and RUN switch must be in Stop-Reset position.
2. Select SETUP Screen.
3. Press CHANGE SETTINGS key.
4. A green box will appear around the first changeable setpoint. Use ▲▼ keys to place box around the MOTOR COMMUNICATIONS PROTOCOL setpoint.
5. Press √ key. A dialog box will appear with the range of settings. Use ◀▶ keys to select “YORK” or “MODBUS”, as appropriate.
6. Press ENTER (✓) key.

Motor Node ID:

(Software version C.OPT.01.18.307 and later)

Only displayed when “Modbus” is selected for the Motor Communications Protocol setpoint above. The Motor Node ID must be set to match the setting of the LCSSS Logic/Trigger Board Modbus Address Switch SW1. The address assigned to the Logic/trigger Board is “1”. This is done by setting Logic/Trigger Board 031-02505 Modbus Address Switch SW1 position 1 to “ON”; all other positions to “OFF”.

1. Chiller must be stopped and RUN switch must be in Stop-Reset position.
2. Select SETUP Screen.
3. Press CHANGE SETTINGS key.
4. A green box will appear around the first changeable setpoint. Use ▲▼ keys to place box around the MOTOR NODE ID setpoint.
5. Press √ key. A dialog box will appear with the range of settings. Use numeric keys to set this value to “1”.
6. Press ENTER (✓) key.

MOD “A” LIQUID COOLED SOLID STATE STARTER

The following procedures can be used to verify the calibration and perform the calibration if necessary. If the Logic Board is field replaced, field calibration is necessary. Logic Board Program Jumper JP5 (300V/600V) must be placed in the appropriate position per the compressor motor AC power line.

Logic Board Program Jumper:

Place Jumper J5 (300V/600V) in appropriate position per the Compressor Motor AC Power Line application as follows:

600V - Place over pins 1 & 2 for 380/400/415, 440/460/480 or 550/575/600 VAC applications.

300V - Place over pins 2 & 3 for 200/208 or 220/230/240 VAC applications.

Setpoints:

1. At the Keypad, log in at SERVICE access level using access code 1 3 8 0.
2. Select MOTOR Screen.
3. Enter the following Setpoints using procedures below:

Full Load Amps :

This is the Full Load Amps (FLA) of the chiller as listed on the Sales Order Screen. The Microboard uses the programmed value to perform Current Limit functions and display compressor motor current in terms of % FLA.

1. Press FULL LOAD AMPS key.
2. Use numeric keypad keys to enter correct value.
3. Press ENTER (✓) key.

Voltage Range:

This is the AC Power line voltage applied to the Compressor Motor. Selections are: 380, 400, 415, 440-480, 550-600 and Supply Voltage Range Disabled. The Microboard uses the programmed selection to determine the overvoltage and undervoltage thresholds for Starter High Supply Line Voltage and Starter Low Supply Line Voltage. Cycling shutdowns as described in Operator Manual 160.54-O1. If Supply Voltage Range Disabled is selected, the thresholds will be ignored and these shutdowns will not occur. This check should not be arbitrarily disabled.

1. Press VOLTAGE RANGE key.
2. Use ◀ and ▶ keys to scroll to desired value.
3. Press ENTER (✓) key.

Current Unbalance Check Enable/Disable:

While the chiller is running, if the compressor Motor current in phase A, B and C becomes unbalanced, a Safety shutdown is performed. Refer to Operator Manual 160.54-O1 for complete description of this check. This Setpoint allows the check to be enabled or disabled. If enabled, the check is performed; if disabled, the check is not performed.

1. Press CURRENT UNBALANCE key.
2. Use ◀ and ▶ keys to select Enable or Disable.
3. Press ENTER (✓) key.

Calibration Verification:

At the Keypad, login at SERVICE access level using access code 1 3 8 0.

1. Compressor Motor current display accuracy -
 - a. Run chiller.
 - b. Select COMPRESSOR Screen.
 - c. Use the Pre-rotation Vanes HOLD keypad key to stabilize the Compressor Motor current.

- d. Measure phase A, B and C Compressor Motor current with a clamp-on ammeter. Compare the Ammeter values with displayed motor current values. If displayed values are not within $\pm 5\%$ of Ammeter values, refer to Solid State Starter Service Manual 160.46-OM3.1 to troubleshoot Starter.
2. Start Current - Proper starting current is (45% x Delta locked Rotor amps).
 - a. Select COMPRESSOR Screen.
 - b. Start chiller and monitor Compressor Motor starting current in phase A, B and C on the COMPRESSOR Screen.
Highest phase should be equivalent to (45% x Delta Locked rotor amps).
 3. Overload -
 - a. Select COMPRESSOR Screen.
 - b. Run chiller and monitor Compressor Motor current on the COMPRESSOR Screen.
 - c. Manually operate the Pre-rotation Vanes by pressing the OPEN, CLOSE and HOLD keys, as required, until the highest phase indicates a current equivalent to 105% FLA.
The Display should indicate 105% and the 105% LED on the Solid State Starter Logic Board should illuminate when the 105% FLA value is reached.

If the calibration verification does not perform as above, one or both of the following Calibration procedures will have to be performed:

Calibration:

At the Keypad, log in at SERVICE access level using access code 1 3 8 0.

1. Start Current -
 - a. Select COMPRESSOR Screen.
 - b. Loosen locking nut on Solid State Starter Logic Board Potentiometer R38.
 - c. Start chiller and monitor Compressor Motor starting current in Phase A, B and C on the COMPRESSOR Screen.
 - d. While chiller is starting, adjust START CURRENT potentiometer (R38) on Solid State Starter Logic Board to achieve the proper starting current of (0.45 x Delta Locked rotor Amps) on the highest phase. Turning R38 Clockwise increases current; Counterclockwise decreases current. Multiple starts could be required to achieve the correct calibration. Tighten locking nut.

2. Overload -
 - a. Select COMPRESSOR Screen.
 - b. Run Chiller and monitor Compressor Motor current on the COMPRESSOR Screen.
 - c. Manually operate the Pre-rotation Vanes by pressing the OPEN, CLOSE and HOLD keypad keys, as required, until the highest phase indicates a current equivalent to 105% FLA. Adjust OVERLOAD potentiometer (R44) on Solid State Starter Logic Board until the 105% FLA LED illuminates. Clockwise increases signal level; Counterclockwise decreases signal level. Tighten locking nut.

Medium Voltage Solid State Starter

1. At the Keypad, log in at SERVICE Access level using password 1 3 8 0.
2. Select MOTOR Screen.
3. Enter the following Setpoints using procedures below:

Full Load Amps:

This is the Full Load Amps (FLA) of the chiller as listed on the Sales Order Screen. The Microboard uses the programmed value to perform Current Limit functions and display compressor motor current in terms of %FLA.

1. Press FULL LOAD AMPS key.
2. Use numeric keypad keys to enter the correct value.
3. Press ENTER Key ($\sqrt{\quad}$) Key.

Start Current:

The starter will limit compressor motor current to this value during starting. The correct value is (0.45 x Delta Locked Rotor Amps), as listed on the Sales Order Screen.

1. Press STARTING CURRENT key.
2. Use numeric keypad keys to enter correct value.
3. Press ENTER ($\sqrt{\quad}$) key.

COMPRESSOR MOTOR VARIABLE SPEED DRIVE APPLICATIONS

When the compressor motor is driven by a YORK Variable Speed Drive, there could be a Variable Speed Drive (VSD) or a Medium Voltage Variable Speed Drive (MV VSD) applied. Early vintage VSD's contain an Adaptive Capacity Control (ACC) Board in the OptiView cabinet that interfaces the microboard using YORK Protocol serial communications. With the later vintage VSD, the ACC functionality resides in the microboard, the ACC Board is not present and the VSD Logic Board directly interfaces the microboard directly using RS-485 Modbus Protocol serial communications. The MV VSD is also interfaced to the microboard with RS-485 Modbus serial communications. Refer to Section 12 for the different possible configurations before proceeding.

1. At the Keypad, log in at SERVICE Access level (unless otherwise noted) using password 1 3 8 0.
2. Enter the following Setpoints using procedures below:

Motor Drive Type:

The Variable Speed Drive type applied must be set as follows. Select the procedure based on the microboard that is present.

- Microboard 031-1730-000: Position Program Jumpers JP37 and JP39 appropriately per Section 3, Table 1.
- Microboard 031-02430-000/001:
 1. Chiller must be stopped and RUN switch must be in Stop-Reset position.
 2. Select SETUP Screen.
 3. Press CHANGE SETTINGS key.
 4. A green box will appear around the first changeable setpoint. Use ▲▼ keys to place box around the MOTOR DRIVE TYPE setpoint.
 5. Press √ key. A dialog box will appear with the range of settings. Use ◀▶ keys to select “VSD-60Hz”, “VSD-50Hz” or “MV VSD”, as appropriate.
 6. Press ENTER (√) key.

Motor Communications Protocol:

(Software version C.OPT.01.16.xxx and later)

Only displayed when Motor Drive Type setpoint above is selected as “VSD-60Hz” or “VSD-50Hz”. The Service Technician must enable the appropriate serial communications port for communications to the Variable Speed

Drive (VSD). Entered as “YORK” to enable COM5 (J15) or “Modbus” to enable COM2 (J13). Selection required is based on the hardware and interface that is present. Refer to Section 12 (VSD) to determine which hardware/interface is present before making selection.

- YORK – Enables COM5 (J15) serial port. Used when the Microboard is interfaced to the Variable Speed Drive via the ACC Board.
- MODBUS – Enables COM2 (J13) serial port. Used when the ACC Board is not present and the Microboard is interfaced directly to the Variable Speed Drive Logic Board. In order to select MODBUS, microboard 031-02430-001 is required and it must be equipped with the 128K BRAM (031-02565-000). With this microboard, Program Jumpers JP14 (BRAM size) and JP17 (COM 2 serial mode) must be configured appropriately per Section 3A Table 3.

1. Chiller must be stopped and RUN switch must be in Stop-Reset position.
2. Select SETUP Screen.
3. Press CHANGE SETTINGS key.
4. A green box will appear around the first changeable setpoint. Use ▲▼ keys to place box around the MOTOR COMMUNICATIONS PROTOCOL setpoint.
5. Press √ key. A dialog box will appear with the range of settings. Use ◀▶ keys to select “YORK” or “MODBUS”, as appropriate.
6. Press ENTER (√) key.

Motor Node ID:

(Software version C.OPT.01.16.xxx and later)

Only displayed when “Modbus” is selected for the Motor Communications Protocol setpoint above. The Motor Node ID must be set to match the setting of the VSD Logic Board Modbus Address Switch SW3. The address assigned to the VSD Logic Board is “1”. This is done by placing the VSD Logic Board Modbus Address Switch SW3 position 1 to “ON” with all other positions to “OFF”, and setting this setpoint to “1

1. Chiller must be stopped and RUN switch must be in Stop-Reset position.
2. Select SETUP Screen.
3. Press CHANGE SETTINGS key.

4. A green box will appear around the first changeable setpoint. Use ▲▼ keys to place box around the MOTOR NODE ID setpoint.
5. Press √ key. A dialog box will appear with the range of settings. Use numeric keys to set this value to "1".
6. Press ENTER (√) key.

Full Load Amps (VSD):

This is the Full Load Amps (FLA) of the chiller as listed on the Sales Order Screen. The Microboard uses the programmed value to perform Current Limit functions and display compressor motor current in terms of %FLA.

1. Place Compressor Start/Stop Switch in the Stop-Reset (O) position.
2. Select VSD DETAILS Screen from the MOTOR Screen.
3. Inside the VSD, locate the small trim pot on the VSD Logic Board; (R34) on Logic Board 031-02506; (R28) on all other Logic Boards.
4. While monitoring the VSD Full Load Amps 000.0 A message on the VSD DETAILS Screen, adjust this trimpot until the correct Full Load Amps value is displayed. Clockwise will increase the value.

Full Load Amps: (MV VSD)

This is the Full Load Amps (FLA) of the chiller as listed on the Sales Order Screen. The Microboard uses the programmed value to perform Current Limit functions and display compressor motor current in terms of %FLA.

1. Select MOTOR Screen
2. Press FULL LOAD AMPS Key.
3. Use NUMERIC Keypad keys to enter the correct value.
4. Press ENTER (√) key.

Pre-rotation Vanes Position Potentiometer:

Refer to the Pre-rotation Vanes Calibration procedure in this section.

Adaptive Capacity Control:

1. Select ACC DETAILS Screen
2. The following keys are available:

- a. Surge Map Clear – Clears all previously established surge points that are stored in memory. When this key is pressed, a dialog box appears requesting the special ACC Map Clear Password. Enter 0 3 6 8 and press the ENTER (√) Key. A message is displayed advising the clearing is in progress. If ACC Board is present, press switch SW1 (for at least 1 second) on the ACC Board within 15 seconds of pressing the ENTER key. Another message is displayed when the clearing has completed. **IMPORTANT!** – This should not be performed unless advised by YORK factory Service.
- b. Surge Map Print – Prints the entire array of stored surge points to a printer connected to COM1 serial port.
- c. Auto Map Print – Prints new surge points, as they are established, to a printer connected to COM1 serial port.
- d. Manual Surge Point – (This key is also available on the SURGE MAP Screen with software version C.OPT.19.307 and later). Captures the instantaneous operating conditions and stores them as a surge point in the surge map. When this key is pressed, a dialog box appears requesting the special password. Enter 0 3 6 8 and press the ENTER key. The chiller must be running to enter this point. If ACC board is present, press switch SW1 (for at least 1 second) on the ACC board within 15 seconds of pressing this key.
- e. Surge Margin Adjust – Refer to Service manual 160.00-M4.
- f. Surge Sensitivity – (software version C.OPT.01.19.307 and later; MODBUS Protocol configuration only) – Sets the sensitivity of the ACC surge detection in the Microboard. Programmable over the range of 1.5 to 2.0 (default 2.0). Smaller values increase the sensitivity.
- g. VSD Start Frequency (software version C.OPT.01.21.307 and later; Modbus Protocol configuration only)- Sets the starting frequency from which the ramp-up will begin. Programmable over the following range: 60Hz units – 30Hz to 60Hz (default 45Hz), 60Hz units with Quick Restart-30Hz to 45Hz (default 45Hz), 50Hz units – 25Hz to 50Hz (default 37.5 Hz), 50Hz units with Quick Restart – 25Hz to 37.5Hz (default 37.5Hz)

- h. ACC Mapping Enable (software version C.OPT.01.21.307 and later; Modbus Protocol configuration only) – Sets the Delta T (Leaving Chilled Liquid Temperature - Setpoint) needed to be met to enable surge mapping and speed reduction initially on startup. Programmable over the range of 0.5°F to 4.0°F (default 1.0°F).
1. Select SURGE MAP Screen (software version C.OPT.01.19.307 and later; MODBUS Protocol configuration only)
 2. The following keys are available:
 - a. Manual Surge Point – see above
 - b. Remove Surge Point – Allows a mapped surge point to be manually removed. Position the green box (□) over the desired surge point marked as “X” on the surge map screen using the keypad arrow keys (▲▼◀▶). Then press the REMOVE SURGE POINT key. A dialog box will appear requesting a special password. Enter 0 3 6 8 and press the ENTER key. The selected point will be removed.

Kilowatt Hours:

1. At the Keypad, log in at ADMIN access level.
2. Select MOTOR Screen.
3. Press KWH RESET key.
4. Use numeric keypad keys to enter desired value.
5. Press ENTER (✓) key.

Frequency Control:

The VSD Frequency can be manually controlled as follows:

1. Select VSD TUNING Screen from the COMPRESSOR Screen.
2. On the VSD Tuning Screen, press the appropriate key as follows:
 - a. Set – Places Frequency Control in Manual Mode. Sets the VSD speed at a specific frequency between 1.0 and 60 (50) Hz.
 - b. Auto – Places the VSD in automatic frequency control. The frequency is determined by the ACC Board to achieve slowest speed possible while avoiding surge.
 - c. Fixed – Sets the VSD frequency at maximum: 60 (50) Hz.
 - d. Raise – Places Frequency Control in Manual Mode. Increases the VSD frequency by 0.1 to 10.0 Hz, as programmed with the INCR AMT (increment amount) key.

Each press of this key increases the frequency by the programmed Amount (0.1 to 10.0 Hz)

- e. Lower – Places frequency Control in Manual Mode. Decreases the VSD frequency by 0.1 to 10.0 Hz, as programmed with the INCR AMT (increment amount) key.

Each press of this key decreases the frequency the programmed amount (0.1 to 10.0 Hz).

- f. Incr Amt - Programmable Setpoint (0.1 to 10.0 Hz) that determines the amount of increase or decrease in VSD frequency that occurs with each press of the INC or DEC key in Manual frequency control mode.

PROXIMITY PROBE

The following applies to all applications except “P” compressors and Style F and later chillers equipped with “G, Q” or “H5-8” compressors: When the Probe is installed at the time of manufacture or after the compressor is rebuilt in the field, a Reference Position is established. This remains the Reference Position until the Compressor is rebuilt. It is the distance (in mils) between the tip of the Probe and the surface of the High Speed Thrust Collar with a minimum of 25 PSID oil pressure. Any distance between 37 and 79 mils is acceptable. This Reference Position is written on a label that is adhered to the inside of the OptiView Control Center door. It is also stored in the BRAM memory device on the Microboard; if the BRAM is replaced, the original Reference Position value must be programmed using the procedure below. A complete description of the Proximity Probe and the Reference Position is contained in the “Proximity Probe” section of this book.

In the procedures below, the Reference Position can be established through a calibration procedure or a previously established Reference Position can be entered, without performing the calibration procedure.

Anytime the chiller shuts down on a Thrust Bearing Safety shutdown, there is the potential that Compressor damage has occurred. Therefore, the shutdown must be evaluated by a qualified Service Technician prior to restarting the chiller. Depending upon the actual shutdown message, the evaluation could require a bearing inspection. To prevent the chiller from restarting without the proper evaluation, restart is inhibited until a special reset procedure is performed. This procedure is listed below and must not be performed by anyone other than a qualified Service Technician.

Calibration:

Perform this procedure at the time of manufacture or if the compressor is rebuilt in the field.

1. At the Keypad, login at SERVICE access level using access code 1 3 8 0.
2. Place Compressor Start/Stop Switch in the Stop-Reset (O) position.
3. Select PROXIMITY PROBE CALIBRATE Screen from COMPRESSOR Screen.
4. On PROXIMITY PROBE CALIBRATE Screen, press START CALIB key to initiate the calibration. The CALIBRATION IN PROGRESS LED will illuminate and the oil pump will start automatically. The oil pressure is displayed on the Screen. If the CANCEL CALIB key is pressed during the procedure, the oil pump is turned off and the calibration is terminated.
5. When the oil pressure has reached 25 PSID, the Program reads the proximity gap and the START CALIB key label changes to ACCEPT CALIB.
6. Press the ACCEPT CALIB key. The measured gap is entered as the Reference Position. Log this value on the Label adhered to the inside of the OptiView Control Center door. This remains the Reference Position until the Compressor is rebuilt.

Reference Position Entry:

Perform this procedure if the Reference Position had been previously established, but lost from memory due to replacement of the BRAM (U52) or other event.

1. At the Keypad, login at SERVICE access level using access code 1 3 8 0.
2. Place the Compressor Start/Stop Switch in the Stop-Reset (O) position.
3. Select PROXIMITY PROBE CALIBRATE Screen from COMPRESSOR Screen.
4. On PROXIMITY PROBE CALIBRATE Screen, press the ENTER REFERENCE key.
5. Locate previously established Reference Position that has been logged on label adhered to inside of OptiView Control Center door. Using numeric keypad keys, enter this value. Only values between 37 and 79 mils will be accepted.
6. Press ENTER (✓) key.

Safety Shutdown Reset/Inspection Procedure:

As explained above, to prevent possible compressor damage, the chiller should not be restarted after a Thrust Bearing safety shutdown until the shutdown has been

evaluated. Therefore, to prevent the chiller from being restarted by anyone other than a qualified Service Technician, the chiller cannot be restarted until the special reset procedure below is performed. The evaluation that has to be performed after each shutdown depends on the actual message displayed and the circumstances of the shutdown (refer to HISTORY Screen) as follows:

- a. THRUST BEARING - PROXIMITY PROBE CLEARANCE - If the shutdown was caused by the gap increasing to $\geq +10$ mils from the Reference Position, perform a Bearing inspection. If there is damage, repair compressor. Otherwise, perform reset procedure below and restart chiller. If shutdown was caused by gap decreasing to ≥ -25 mils from the Reference Position, perform the reset procedure below and restart the chiller.
- b. THRUST BEARING - PROXIMITY PROBE OUT OF RANGE - Perform reset procedure below and restart chiller.
- c. THRUST BEARING - HIGH OIL TEMPERATURE (Not applicable to chillers equipped with Program version C.MLM.01.03 or higher) - If there have been two consecutive shutdowns, perform a Bearing inspection. Otherwise, perform reset procedure below and restart chiller.
- d. THRUST BEARING - OIL TEMPERATURE SENSOR (Not applicable to chillers equipped with Program version C.MLM.01.03 or higher) - Perform reset procedure below and restart chiller.

Reset Procedure:

In order for the following procedure to be successful, the Proximity clearance must be between +10 and -25 mils of the Reference Position and the High Speed Drain Temperature must be $>50.0^{\circ}\text{F}$ and $\leq 179^{\circ}\text{F}$.

1. Place the Keypad Rocker Switch in the Stop-Reset (O) position.
2. At the Keypad, login at SERVICE access level using access code 1 3 8 0.
3. After Coastdown is complete, select PROXIMITY PROBE CALIBRATE Screen from COMPRESSOR Screen.
4. Press FAULT ACKNOWLEDGE key. ENTER PASSWORD TO CLEAR FAULT is displayed in a dialog box.
5. Enter 1 3 9 7 and press the ENTER (✓) key. This clears the fault and allows the chiller to be started.

HIGH SPEED THRUST BEARING LIMIT SWITCH

The following is only applicable to chillers equipped with “P” compressors and style F and later chillers with “G, Q” or “H5-8” compressors: Anytime the chiller shuts down on a High Speed Thrust Bearing safety shutdown, displaying the message “THRUST BEARING - LIMIT SWITCH OPEN”, there is the potential that compressor damage has occurred. Therefore, a bearing inspection must be performed by a qualified Service Technician prior to restarting the chiller. To prevent the chiller from restarting without the proper bearing evaluation, restart is inhibited until a special reset procedure is performed, as detailed below.

1. Place the COMPRESSOR Switch in the Stop-reset position.
2. At the Keypad, login at SERVICE access level using access code 1 3 8 0.
3. Select COMPRESSOR Screen.
4. After Coastdown is complete, press FAULT ACKNOWLEDGE Key. “Enter Password to Clear Fault” is displayed in a dialog box.
5. Enter 1 3 9 7 and press the ENTER (✓) key. If the Limit Switch is closed, this clears the fault and allows the chiller to be started.

REFRIGERANT LEVEL CONTROL

A complete description of the Condenser refrigerant level control and the Setpoints that affect this control are provided in the “Refrigerant Level Control” section of this book. These setpoints are listed below. The Program uses these setpoints to control the refrigerant to the desired level. If the chiller is equipped with this feature, the Program control must be ENABLED and the Setpoints programmed using the procedure below.

The refrigerant level can be manually controlled through manual control of the Variable Orifice using the procedure below.

The refrigerant Level Sensor, located in the Condenser, must be properly calibrated to accurately detect the refrigerant level in the Condenser. The procedure below is used to perform this calibration.

Enable/Disable:

If the chiller is equipped with the Refrigerant Level Control, Level control operation must be “Enabled”. Otherwise, it must be “Disabled”. Use following procedure:

1. At the Keypad, log in at SERVICE access level, using access code 1 3 8 0.
2. Select SETPOINTS Screen. From SETPOINTS Screen select SETUP Screen. From SETUP Screen select OPERATIONS Screen.
3. Use ◀ and ▶ keys to select Enable or Disable.
4. Press ENTER (✓) key.

Setpoints:

The following are the Setpoints and range of programmable values. The DEFAULT value is shown in parenthesis. The DEFAULT value is the recommended value and should provide proper operation in most applications. However, the Setpoint can be programmed to other values to compensate for local operating conditions. There are two different setpoint sets used depending upon the software vintage. Select the appropriate procedure per the installed software as follows:

Software version C.MLM.01.11.xxx (and earlier) or C.OPT.01.11.xxx (and earlier)

- a. Level Setpoint - 20% to 80% (50%)
- b. Level Control Period - 1.0 to 5.0 seconds. 3.5 to 30 seconds (Flash Memory Card version C.MLM.01.06.xxx and later and “P” compressors with C.MLM.04.02.xxx).
The Default value varies depending upon the Flash Memory Card version and compressor application: versions C.MLM.01.06.xxx and earlier (3.5 seconds); version C.MLM.01.07.xxx and later (10.0 seconds “P” compressors; 3.5 seconds all other compressors)
- c. Proportion Limit Open - 10% to 50% (15%)
- d. Proportion Limit Close - 10% to 50% (45%)
- e. Rate Limit Open - 10% to 50% (10%) 5% to 50% (10%) (Flash Memory Card version C.MLM.01.06.xxx and later or C.MLM.04.02.xxx).
- f. Rate Limit Close - 10% to 50% (10%). 5% to 50% (10%) (Flash Memory Card version C.MLM.01.06.xxx and later or C.MLM.04.02.xxx)
- g. Valve Preset Time – 0 to 100 seconds (50 seconds) (Flash memory Card version C.MLM.01.07.xxx and later)
- h. Ramp-up Time – 3 to 15 minutes (8 minutes) (Flash Memory Card version C.MLM.01.07.xxx and later)

1. At the Keypad, log in at SERVICE access Level using access code 1 3 8 0.
2. Select REFRIGERANT LEVEL CONTROL Screen from the CONDENSER Screen.
3. On the REFRIGERANT LEVEL CONTROL Screen, select the setpoint to be programmed or press the SETPOINTS key for more setpoints
4. Using the numeric keypad keys, enter desired value.
5. Press ENTER (✓) key.

Software version C.MLM.01.14.xxx (and later) or C.OPT.01.14.306(and later)

	<u>Zone 1</u>	<u>Zone 2</u>
Rate Limit	3% to 15% Default 7	3% to 15% Default 5
Period (seconds)	8 to 22 default 15	2.5 to 10 Default 2.5

	<u>Zone 1 & Zone 2</u>
Level Setpoint	20% to 80% Default 50%.

(30% software version C.OPT.01.18.307 and earlier)

Valve Preset Time (setpoint) (seconds) 0 to 100
Default 50

Ramp Up Time (setpoint) (minutes) 3 to 15
Default 8

Proportion Error Deadband - +0%
Rate Error Deadband – +0%

1. At the Keypad, login at SERVICE access level using access code 1 3 8 0.
2. Select the Refrigerant Level Control Screen from the Condenser Screen.
3. Press the appropriate key to select the setpoint to be programmed.
(If selecting Period or Rate setpoint, press the SET ZONES key. A green box appears around the first changeable setpoint. Use the ▲, ▼, ◀, ▶ keys to place the green box around the desired setpoint to be changed. Press ENTER (✓) key. A dialog box will appear with the range of settings)
4. Using the numeric keypad keys, enter the desired value.

5. Press ENTER (✓) key.

Manual Control:

The Variable Orifice can be manually controlled as follows:

1. At the Keypad, log in at SERVICE access level using access code 1 3 8 0.
2. Select REFRIGERANT LEVEL CONTROL Screen from the CONDENSER Screen.
3. On the REFRIGERANT LEVEL CONTROL Screen, press the OPEN, CLOSE or HOLD key as required to control the Variable Orifice to achieve the desired refrigerant level. Pressing the AUTO key invokes automatic operation.

Level Sensor Calibration:

There are two different versions of the Refrigerant Level Sensors. The operation of both the sensors is the same. However, the difference is in the calibration adjustments. Some sensors are equipped with adjustable potentiometers labeled “S”(span) and “Z”(zero). Others are equipped with calibration pushbuttons labeled “F/UP”, “E/DN”, “MAX”, and “MIN”.

The calibration instructions for the Refrigerant Level Sensor is contained in Service Instruction SI0187.

OIL PUMP VARIABLE SPEED DRIVE

On certain model chillers, the oil pump is driven by a small Variable Speed Drive. A complete description of the Drive operation and the Setpoints that affect this control are provided in the “Oil Pump Variable Speed Drive” section of this book. The Setpoints are listed below. The Program Variable Speed Drive operation must be ENABLED and the Setpoints programmed using the procedures below. Also, the Oil Pump Speed can be manually controlled using the procedure below.

Enable/Disable:

The Oil Pump Variable Speed Drive Program operation must be enabled.

The procedure varies according to the microboard installed as follows:

Microboard 031-01730-000
Program Switch SW1-2 ON – Enabled
OFF - Disabled

Microboard 031-02430-000/001

Entered as setpoint on SETUP Screen. Follow procedure later in this section under “Microboard 031-02430-000/-001 Setup/Configuration”

Setpoints:

The following are the Setpoints and range of programmable values. The DEFAULT values (shown in parenthesis) are the recommended values and should provide proper operation in most applications. However, the Setpoints can be programmed to other values as required. Enter Setpoints using procedure below:

- a. Oil Pressure Setpoint - 20 to 45 PSID (35)
 - b. Control Period – 0.3 to 2.7 seconds in 0.3 second increments. (0.3)
1. At the Keypad, log in at SERVICE access Level using access code 1 3 8 0.
 2. Select OIL SUMP Screen.
 3. On the OIL SUMP Screen, press the appropriate key to select the Setpoint to be programmed.
 4. If the Dialog box begins with the word “Enter”, use the numeric keypad keys to enter the desired value. If it begins with “Select”, use the ◀ and ▶ keys to select desired value.
 5. Press ENTER (✓) key.

Manual Control:

The Oil Pump speed can be manually controlled between 25 and 60(50) Hz as follows:

1. At the Keypad, log in at SERVICE access level using access code 1 3 8 0.
2. Select OIL SUMP Screen.
3. The speed can be increased and decreased in 0.5 Hz increments using the RAISE and LOWER keys. Each time the key is pressed, the frequency is changed 0.5 Hz.

OR

The speed can be set to a specific frequency, as programmed by the SET key as follows:

1. Press SET key.
2. Use the numeric keys to enter the desired value.
3. Press ENTER (✓) key.
4. If the AUTO key is pressed, automatic speed control is invoked.

OIL RETURN MIN

(Software version C.OPT.01.21.307 and later; P,Q,H9 compressors only)

To avoid an “Oil – Low Temperature Differential” cycling condition from preventing a chiller start after running at low load conditions for extended periods, the Oil Return Solenoid (1SOL) is cycled closed when the oil temperature gets too low on the P, Q and H9 compressor chillers, while the chiller is running. The OIL RETURN MIN Setpoint key appears on the Oil Sump Screen when the CHILLER STYLE/COMPRESSOR TYPE Setpoint (on the Operations Screen) is set to P, Q or H9 compressor in Service access level. This setpoint is programmable over the range of 80.0°F to 110.0°F (default 95.0°F) and controls the oil return Solenoid as follows:

- When the compressor is running and the Oil Sump Temperature < Oil Return Min Setpoint, close (de-energize) the Oil Return Solenoid by de-energizing K12 relay
- When the compressor is running and Oil Sump Temperature > Oil Return Min + 7°F, open (energize) the Oil Return Solenoid by energizing K12 relay.
- During coastdown, the solenoid operation is not changed from standard logic, it remains closed. During startup the operation is not changed from standard logic, it remains closed for 1 minute after System Run.

In previous software versions, the Oil Return Solenoid (1SOL) is opened 1 minute into System Run and remains open until System Coastdown.

STANDBY LUBRICATION

To maintain oil seal integrity while the chiller is shut-down, a feature can be enabled that turns on the Oil Pump for 2 minutes every 24 hours if the chiller has not been run in the past 24 hours. While the Oil Pump is running, "STANDBY LUBE IN PROCESS", along with a countdown timer displaying the time remaining in the lube cycle is displayed. If the chiller is style “D” equipped with an Oil Pump Variable Speed Drive, the operating oil pressure will be the programmed Oil Pressure Setpoint.

If at least 15 PSID of oil pressure is not achieved within 30 seconds of turning on the Oil Pump, the cycle is terminated and WARNING - STANDBY LUBE - LOW OIL PRESSURE is displayed and no more standby lubrications will occur until a.) the FAULT ACKNOWLEDGE keypad key is pressed after login at SERVICE access level, at which point another lube cycle will be attempted or b.) the chiller is started.

Standby lubrication cycles will not be performed if either oil pressure transducer is reading a pressure out of its range ($HOP \leq 6.8$ PSIG; $LOP \leq 0$ PSIG). This assures that the oil pump will not be turned on with the shells at atmospheric pressure, as they would be during maintenance.

When logged in at SERVICE access level, the time remaining until the next Standby lubrication cycle is displayed as NEXT OIL SEAL LUBRICATION = XX HRS on the OIL SUMP Screen.

To Enable or Disable the Standby lubrication cycles, proceed as follows:

1. At the keypad, log in at SERVICE access level using access code 1 3 8 0.
2. Select OIL SUMP Screen.
3. Use ◀ and ▶ keys to select Enable or Disable.
4. Press ENTER (✓) key.

HIGH CONDENSER PRESSURE WARNING THRESHOLD

The condenser pressure at which a High Pressure warning message is displayed and the Pre-rotation Vanes are inhibited from further opening, is programmable over the range of 44.9 to 162.5 PSIG (R134a), or 84.0 to 246.3 PSIG (R22). The Default value for R134a is 162.5 PSIG. The Default for R22 is 246.3 PSIG. The Warning message will clear and the PRV inhibit is removed when the pressure decreases to 5 PSIG below the programmed value. Proceed as follows to enter this value:

1. At the Keypad, log in at SERVICE access level using access code 1 3 8 0.
2. Select CONDENSER Screen.
3. On the Condenser Screen, press HIGH PRESSURE WARNING THRESHOLD key.
4. Using numeric keypad keys, enter desired value.
5. Press ENTER (✓) key.

BRINE LOW EVAPORATOR PRESSURE CUTOUT

On Brine cooling applications, the Low Evaporator Pressure safety shutdown threshold is programmable over the range of 25.0 to 54.3 PSIG (Default 54.3 PSIG) for R22 Refrigerant and 6.0 to 25.0 PSIG (Default 25.0 PSIG) for R134a Refrigerant. The actual percentage of Brine solution determines this threshold. It is calculated at the YORK Factory and programmed at the time of manufacture. If the BRAM memory device on the Microboard is replaced, the threshold will have to be programmed in

the field. The threshold is logged on an adhesive label attached to the inside of the OptiView Control Center door. Proceed as follows to enter this value:

1. At the Keypad, log in at SERVICE access level using access code 1 3 8 0.
2. Select EVAPORATOR Screen.
3. On the EVAPORATOR Screen, press the BRINE LOW EVAPORATOR CUTOFF key.
4. Using numeric keypad keys, enter desired value.
5. Press ENTER (✓) key.

LEAVING CHILLED LIQUID TEMPERATURE CONTROL SENSITIVITY

This Setpoint adjusts the Leaving Chilled Liquid Temperature control sensitivity. It determines the magnitude of Pre-rotation Vanes (PRV) response to correct the error between the Leaving Chilled Liquid Temperature Setpoint and the actual liquid temperature leaving the chiller. There are three selections as follows:

- Normal - Provides standard control operation. PRV open and close pulses are standard durations for any given error. Longest allowed pulse is 18 seconds in duration. This selection will provide proper operation in most applications.
- 50% - Provides less sensitivity than the NORMAL selection. The longest allowed open or close pulse is limited to 50% of the maximum allowed with the NORMAL selection. This provides less overall PRV movement than the NORMAL selection. This selection will reduce PRV instability in short chilled liquid loops, multi-pass chillers, parallel chiller configurations and other applications that cause PRV instability.
- 30% - Provides less sensitivity than the 50% selection. The longest allowed open or close pulse is limited to 30% of the maximum allowed with the NORMAL selection. This provides less overall PRV movement than the 50% selection. It's beneficial in the same applications as the 50% selection, but that require greater stability. This selection available with Flash Memory Card version C.MLM.01.06.xxx and later or C.MLM.04.02.xxx).

Flash Memory Card version C.MLM.01.06.xxx and later or C.MLM.04.02.xxx have special variable speed low load operation as follows: If the chiller is equipped with

the YORK compressor motor Variable Speed Drive and the 50% or 30% Sensitivity is selected, the Pre-rotation Vane (PRV) movement is reduced further than described above when the chiller is operating at low load. When the PRV position is < 25% and the Leaving Chilled Liquid Temperature is within ± 2.5 °F of Setpoint, the maximum allowed vane pulse is limited to 3.5 seconds at the 25% PRV position and 0.9 seconds at 0% position. PRV positions in between have linearly scaled maximums.

Proceed as follows to select this value:

1. At the Keypad, log in at SERVICE access level using access code 1 3 8 0.
2. Select EVAPORATOR Screen.
3. Press SENSITIVITY key.
4. Use ◀ and ▶ keys to select desired value.
5. Press ENTER (✓) key.

DROP LEG REFRIGERANT TEMPERATURE

The chiller can be equipped with a refrigerant temperature sensor in the drop leg between the condenser and evaporator. If “Enabled” with the procedure below, this temperature is displayed on the CONDENSER Screen as the “Drop Leg Temperature”. It is subtracted from the Condenser Saturation Temperature to produce “Sub Cooling Temperature”, also displayed on the Condenser Screen. If the chiller is equipped with the Drop Leg Refrigerant Temperature sensor, the values are displayed on the CONDENSER Screen only if enabled with the following procedure.

1. At the Keypad, log in at SERVICE access Level using access code 1 3 8 0.
2. Select CONDENSER Screen.
3. Press DROP LEG key.
4. Use ◀ and ▶ keys to select Enable or Disable.
5. Press ENTER (✓) key.

SMART FREEZE PROTECTION

This feature is described in the “Smart Freeze Protection” section of this book. When turned on, it allows the Leaving Chilled Liquid Temperature Setpoint to be as low as 36°F for water cooling applications. Along with this feature is a correspondingly lower Low Water Temperature Cycling Shutdown threshold and Low Evaporator Pressure Safety Shutdown threshold. The Smart Freeze Protection feature can be turned ON or OFF using the following procedure:

1. Shutdown the chiller and wait for completion of COASTDOWN.
2. At the Keypad, log in at SERVICE access level using access code 1 3 8 0.
3. Select EVAPORATOR Screen.
4. Press SMART FREEZE key.
5. Use ◀ and ▶ keys to select ON or OFF.
6. Press ENTER (✓) key.

EVAPORATOR REFRIGERANT TEMPERATURE

If the chiller is equipped with an Evaporator Refrigerant Temperature sensor, the feature must be Enabled with the procedure below. If not equipped with this sensor, it must be Disabled. If enabled, this temperature is displayed on the EVAPORATOR Screen, and is also used in the Smart Freeze Protection Low Evaporator Pressure Safety Shutdown threshold calculation, as explained in the “Smart Freeze Protection” section of this book.

Use the following procedure to Enable or Disable this feature:

1. At the keypad, log in at SERVICE access level using access code 1 3 8 0.
2. Select EVAPORATOR Screen.
3. Press REFRIGERANT key.
4. Use ◀ and ▶ keys to select Enabled or Disabled.
5. Press ENTER (✓) key.

HOT GAS BYPASS CONTROL

A complete description of the optional Hot Gas Bypass Control and the Setpoints that affect this control are provided in the “Hot Gas Bypass” section of this book. The Setpoints are listed below. If the chiller is equipped with this feature, it must be “Enabled” and the setpoints programmed using the procedure below. Otherwise, it must be “Disabled”. The Hot Gas valve can be manually controlled using the procedure below. The total lifetime Surge Count can be cleared. However, this should NOT be arbitrarily performed! Since the Pre-Rotation Vanes (PRV) position is used in the Hot Gas control, the PRV position feedback potentiometer must be calibrated with the procedure below.

Enable/Disable:

If the chiller is equipped with the optional Hot Gas Bypass control, operation must be “enabled”. Otherwise, it must be “disabled”. Use the following procedure:

1. Shutdown chiller and place COMPRESSOR Start/stop Switch in the Stop-Reset (O) position.
2. At the Keypad, log in at SERVICE access level, using password 1 3 8 0.
3. Select SETPOINTS Screen. From SETPOINTS Screen, select SETUP Screen. From SETUP Screen, select OPERATIONS Screen.
4. Use ◀ and ▶ keys to select Enable or Disable.
5. Press ENTER (✓) key.

Setpoints:

The following are the Setpoints and range of programmable values. The DEFAULT value is shown in parentheses. The Default value is the recommended value and should provide proper operation in most applications. However, the Setpoint can be programmed to other values to compensate for local operating conditions. There are two different setpoint sets used depending upon the software vintage. Select the appropriate procedure per the installed software as follows:

1. At the Keypad, login at SERVICE access level using password 1 3 8 0.
2. Select HOT GAS BYPASS Screen from the COMPRESSOR Screen.
3. On the HOT GAS BYPASS Screen, press the appropriate key to select the Setpoint to be programmed.
4. Using the numeric Keypad keys, enter the desired value.
5. Press ENTER (✓) key.

Manual Control:

The Hot Gas Valve can be manually controlled as follows:

1. At the Keypad, log in at SERVICE access level using password 1 3 8 0.
2. Select HOT GAS BYPASS Screen from the COMPRESSOR Screen.
3. On the HOT GAS BYPASS Screen, press the OPEN or CLOSE keys as desired. Each time the key is pressed, the valve position will be increased or decreased 5%. Pressing the AUTO key invokes automatic operation.

Pre-rotation Vanes Position Potentiometer Calibration:

Refer to the Pre-rotation Vanes Calibration procedure in this section.

CHILLER STARTS AND OPERATING HOURS RESET

The Number of Starts and the Operating Hours can be reset to zero or preset to a desired number. However, this should never be arbitrarily performed. Use the following procedure:

1. At the keypad, login at ADMIN access level. This password changes daily. Contact your local YORK Service Office.
2. Select OPERATIONS screen.
3. Press NUMBER of STARTS or OPERATING HOURS key as appropriate.
4. Using numeric keypad keys, enter desired number.
5. Press ENTER key (✓) key.

SERVICE PHONE NUMBERS

(Applies to Flash Memory Card version C.MLM.01.05. xxx and later)

Two service phone numbers (Regional and Local), with labels, can be displayed on the OPERATIONS Screen. The Default value for the Regional number is the “North American Toll Free Number” (1-800-861-1001). However, the label and number can be changed to any desired value. The Default value for the Local label and number is blank. The Service Technician enters the Local phone number and label.

The entry format consists of 4 fields (rows), vertically from the top. Up to 40 characters/numbers can be entered for each field.

Field 1 – Regional phone number label. Default value is “YORK Intl North American Toll Free Number”

Field 2 – Regional phone number. Default value is 1-800-861-1001.

Field 3 – Local service phone number label. Default value is blank.

Field 4 – Local service phone number. Default value is blank.

Use the following procedure to change any of the fields:

1. At the Keypad, login at SERVICE access level using access code 1 3 8 0.
2. Select OPERATIONS Screen.
3. Press EDIT PHONE NUMBERS Key.
4. Use ▲ and ▼ keys to move green selection box to the desired field to be changed.
5. Press the ENTER (✓) key.
6. In the Dialog box that appears, a red box appears over the first changeable value. Use the ◀ and ▶ keys to position the red box over the number character to be changed or entered. Use the ▲ and ▼ keys to scroll sequentially through numbers, alphabet characters and punctuation marks to select the desired value. When the desired value displayed, use the ◀ and ▶ keys to move the red box to the next value to be changed. The numeric keypad keys can also be used to enter numbers. Continue this process until all desired values have been entered.
7. After all desired values have been entered in previous step, press ENTER (✓) key.

SURGE PROTECTION

(Applies to Flash Memory Card version C.MLM.01.05.xxx and later)

A complete description of the Surge Protection feature and setpoints that affect this control are provided in the “Surge Protection” section of this book. Although most setpoints are entered with Operator access level, the Surge Sensitivity setpoint and Total Surge Count clearing require Service access level or higher.

Surge Sensitivity:

1. At the keypad, log in at SERVICE access level, using 1 3 8 0.
2. Select SURGE PROTECTION Screen from COMPRESSOR Screen.
3. Press SURGE SENSITIVITY key.
4. Using numeric and decimal point keypad keys, enter desired value. Programmable over range of 0.3 to 1.3. Default value is 0.3. Use leading zeroes where necessary and place decimal point between first and second digit (ie; 0.3, 1.2, etc.)
5. Press ENTER (✓) key.

Clear Surge Count:

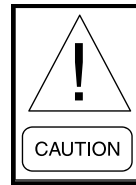

This should NOT be arbitrarily performed.

1. At the keypad, log in at ADMIN access level. Obtain ADMIN password from local service office. This password changes daily.
2. Select SURGE PROTECTION Screen from COMPRESSOR Screen.
3. Press CLEAR SURGE COUNT key.

SALES ORDER DATA

All of the Sales Order Data, except the “Chiller Commissioning Date” is entered at the YORK Factory at the time of chiller manufacture. The Service Technician must enter the Chiller Commissioning Date and modify the Job Name or Job Location if necessary at the completion of commissioning. Normally, the remainder of the Sales Order Data should never be modified. However, if there is a change to the chiller design, in the field, this data can be modified. If the BRAM battery-backed memory device fails and requires field replacement, all of the data will be lost and will have to be manually programmed.

When replacing a microboard, it might be desirable to transfer the BRAM from the defective board to the replacement board to save stored Sales Order data. Since not all BRAM devices are compatible with all microboards, first determine if the BRAM can be transferred before making the transfer. Refer to the Microboard Service Replacement section of SECTION 3A of this manual.

There are three different Passwords used, depending on the circumstances, to change the Sales Order Data as follows:

- **Chiller Commissioning** - Service Technician must use password **1 3 8 0** to enter the Commissioning Date and modify Job Name and Job Location if necessary.
- **Modifying Sales Order Data** - Service Technician must use the ADMIN password. This password changes daily. Contact your local YORK Service Office.
- **BRAM Replacement** - If the BRAM is field replaced, the Service Technician must use password **0 2 2 8** to enter all Sales Order Data into a new blank BRAM. When logged in at this level, the ACCESS

LEVEL shown will be TEST OP. This password only works with a blank BRAM and is only applicable to chillers equipped with Flash Memory Card Version C.MLM.01.01 and later.



When using this password to enter data into a new blank BRAM, the FINISH PANEL SETUP procedure (listed at the end of the entry procedure below) must be performed after all data has been entered. Failure to perform this procedure will result in unreliable OptiView Control Center operation! If this procedure is performed prior to entering all data, the ability to enter more data will be terminated.

Use the following procedure to enter data:

1. At the keypad, log in at the appropriate Access Level to change the desired values.
2. From the SETPOINTS Screen, select SETUP SCREEN. From the SETUP Screen, select SALES ORDER Screen.
3. If logged in at SERVICE Access level, press SET ORDER INFO key to enter Commissioning date, Job Name or Location and proceed to step 4. If logged in at ADMIN or TEST OP level, Press SELECT key to select the data category (ORDER, DESIGN, NAMEPLATE, SYSTEM) to be entered.
4. Press CHANGE key. The first changeable area in the selected category will be outlined in a green selection box. The procedure can be terminated anytime after this by pressing the CANCEL (X) key.
5. Use the ▲ and ▼ keys to move the green selection box to the desired value to be changed, within the category selected.
6. Press ENTER (✓) key.
7. Enter the appropriate data. Use the numeric keypad keys to enter numbers. Use the • key to enter a decimal point. Use the ▲ and ▼ keys to scroll sequentially up and down through the alphabet to enter letters or a comma (,), slash (/) or minus sign (-). Each time the ▲ key is pressed, the next higher sequential alphabet letter is displayed. Each time the ▼ key is pressed, the next lower alphabet letter is displayed. The comma, slash and minus sign can be selected after scrolling through the entire alphabet. During the entry process, the ◀ key can be used to backspace and the ▶ key can be used to forward space.
8. Press ENTER (✓) key.
9. Use ▲ and ▼ keys to select another value to be changed within the same category or press CANCEL (X) key to exit and allow selection of another category.
10. **EXTREMELY IMPORTANT!** If the procedure above was performed using password 0 2 2 8 to enter data into a new blank BRAM, the following procedure must be performed after all the desired data is entered. If the following procedure is performed prior to entering all of the data, the ability to enter more data will be terminated. Failure to perform this procedure after all data has been entered will result in unreliable OptiView Control Center Operation!
 - a. On SALES ORDER screen, press FINISH PANEL SETUP key.
 - b. Use ◀ and ▶ key to select YES.
 - c. Press ENTER (✓) key.

CUSTOM USER ID AND PASSWORDS

When logging in, the user is requested to enter a User ID, followed by a Password. The universal and Default User ID is zero (0). The universal Password to log in at OPERATOR access level is 9 6 7 5. The universal Password to log in at SERVICE access level is 1 3 8 0. No log in is required for VIEW access level. However, if desired, the service technician can establish up to four custom User ID's and Passwords that can be used by Operations personnel to log in at VIEW, OPERATOR, or SERVICE level.

Up to four Custom Users can be established with User ID's from 1 to 9999. Each user can be assigned a Password of 0 to 9999 and an access level of VIEW, OPERATOR or SERVICE.

Use the following procedure to establish Custom Users:

1. At the Keypad, log in at SERVICE access level using 1 3 8 0.
2. From the SETPOINTS Screen, select SETUP Screen. From SETUP Screen, select USER Screen.
3. Press CHANGE USER ATTRIBUTES key. The first changeable area is outlined in a green selection box.
4. Use the ◀, ▶, ▲ or ▼ keys to move the green selection box to the desired value to be changed.
5. Press the ENTER (✓) key.

6. Using numeric Keypad keys, enter desired parameter as follows:
 - User ID – 1 to 9999 (numbers cannot be duplicated for more than one user)
 - Password – 0 to 9999
 - Access Level – 0 = View, 1 = Operator, 2 = Service
7. Press ENTER (✓) key.
8. After all values have been entered, press CANCEL key (X) to exit.

RECORD SETPOINT CHANGES

(Flash memory Card version C.MLM.01.06.xxx and later or C.MLM.04.02.xxx)

This feature provides a record of the last 75 Setpoint changes. The date and time the Setpoint was changed, the new Setpoint value and the Access Level and User ID used to make the change are stored. The SECURITY LOG Screen and the SECURITY LOG DETAILS Screen display levels of this information.

On the SECURITY LOG Screen, accessible from the HISTORY Screen, the Setpoint, Setpoint Category and new Setpoint value are listed and numbered in reverse order in which they were changed. The most recent is listed as number 1; the next most recent as number 2, etc. A PRINT key allows printing this entire list. Since 15 changes can be displayed at one time, multiple pages could be necessary to display all the changes. PAGE-UP and PAGE-DOWN keys are provided to view the entire list. If it is desired to view the details of a particular Setpoint change, select the Setpoint change number with the LOG ENTRY key and then press the VIEW DETAILS key. This moves to the SECURITY LOG DETAILS Screen.

The SECURITY LOG DETAILS Screen displays the following Setpoint change details. The Setpoint is selected from the list on the SECURITY LOG Screen as explained in the previous paragraph.

- Setpoint Category
- Setpoint
- Date and time of change
- Access Level and User ID used to make the change
- Old Value
- New Value

The following Setpoint changes are not logged:

- Clock Mode
- Custom Screen Slot Numbers
- Advanced Diagnostics Communication Port Tests

- Advanced Diagnostics Secondary Multiplexer Freeze
- Soft Shutdown Initiated by Operator
- System Language
- Display Units
- Any Print Report
- Cancel any Print Report
- Schedule Clear
- Schedule Repeat Exception Days
- Schedule Start and Stop Times
- Log In/Log Out
- User Attributes for ID, Password and Level
- Trend Start/Stop
- Trend Slot Numbers, Minimums and Maximums
- Trend Trigger Data
- Trend Print Mode
- Trend View Mode

View the Setpoint changes as follows:

1. At the Keypad, login at SERVICE Access Level using access code 1 3 8 0.
2. From the HISTORY Screen, select SECURITY LOG Screen to view the complete list of setpoint changes.
3. To view the details of a particular setpoint change, select it with the LOG ENTRY key, then press VIEW DETAILS key. This causes a jump to the SECURITY LOG DETAILS Screen where the setpoint change details are displayed.

CHILLER STYLE/COMPRESSOR

(Flash Memory Card version C.MLM.01.07.xxx and later)

If equipped with Flash memory Card version C.MLM.01.07.xxx and later, the Chiller Style/Compressor combination must be entered. The various YK chiller style/compressor combinations are equipped differently and have different control requirements. Variables include the following:

- High Speed Thrust bearing proximity sensing – Proximity Probe input at Microboard J8-15 or Limit Switch input at I/O Board TB3-81.
- Flow Sensor – Paddle type or Factory Mounted Thermal Type. The paddle type applies 115Vac to the I/O Board DIGITAL inputs TB4-12 (evaporator) and TB4-11 (condenser). The factory mounted thermal type (available with style F chillers), applies +5Vdc to the microboard ANALOG inputs at J7-14 (evaporator) and J7-16 (condenser). Flash Memory Card version C.MLM.01.07.xxx and

C.MLM.01.07A.xxx automatically selects the Flow Sensor input, either Analog or Digital per the Chiller Style/Compressor Setpoint selection. Flash Memory Card version C.MLM.01.08.xxx (and later), allows the use of either the Thermal type (Analog) or Paddle-type (Digital) flow sensors in the style F chillers. With these versions, the actual Flow Sensor type present must be entered using the Flow Switch Setpoint.

- Oil Heater Outputs – Either TB1-34 or TB1-64 on I/O Board
- Refrigerant Level Control Default Period – Either 3.5 seconds or 10.0 seconds
- “Oil – Variable Speed Pump-Pressure Setpoint Not Achieved” safety shutdown threshold – Either 25 PSID or 35 PSID

Flash Memory Card version C.MLM.01.07.xxx and later are applicable and backward compatible to all YK chiller style/compressor combinations. They contain all control variables for all combinations. For correct chiller control, the correct CHILLER STYLE/COMPRESSOR combination must be entered. Once the applicable Chiller/Compressor combination is entered, the program automatically bundles the functionality and chiller control per the tables below.

For example, if equipped with C.MLM.01.08.105A (or later):

Example 1:

If the chiller is a style F and equipped with a J or H3 compressor, enter “Style F/J,H3 Compr”. The program will read the Proximity Probe input at Microboard J8-15, control the Oil Heater from TB1-64, make the Level Control Period Default 3.5 seconds, the Oil Pressure safety threshold below is 35 PSID and will read the Flow Sensor inputs at either I/O Board TB4-11/12 or Microboard J7-14/16 as programmed with the FLOW SWITCH Setpoint.

Example 2:

If the chiller is a style E and equipped with a P compressor, enter “Style E/P Compr”. The program then reads the Proximity Limit Switch at I/O Board TB3-81, controls the Oil Heater from TB1-64, makes the Level Control Period Default 10.0 seconds, the Oil Pressure safety threshold below would be 25 PSID and reads the Flow Sensor input at I/O Board TB4-11/12.

FLASH MEMORY CARD VERSION C.MLM.01.07.XXX AND C.MLM.01.07A.XXX

Chiller Style/Compressor	Proximity Sense	Oil Heater Output*	Level Control Period Default	Flow Switch	“Oil-Variable Speed Pump Pressure Setpoint Not Achieved” Threshold*
“Style CDE/GHJ Compr”	Probe	TB1-34	3.5 sec	Digital (Paddle Type)	35 PSID
“Style E/P Compr”	Limit Switch	TB1-64	10.0 sec	Digital (Paddle Type)	25 PSID
“Style F/GH Compr”	Limit Switch	TB1-64	3.5 sec	Analog (thermal type)	35 PSID
“Style F/J Compr”	Probe	TB1-64	3.5 sec	Analog (thermal type)	35 PSID
“Style F/P, Compr”	Limit Switch	TB1-64	10.0 sec	Analog (thermal type)	25 PSID

* Not applicable to Style C and earlier chillers.

FLASH MEMORY CARD VERSION C.MLM.01.08.XXX

Chiller Style/Compressor	Proximity Sense	Oil Heater Output*	Level Control Period Default	Flow Switch	"Oil-Variable Speed Pump Pressure Setpoint Not Achieved" Threshold*
"Style CDE/GHJ Compr"	Probe	TB1-34	3.5 sec	Digital (Paddle Type)	35 PSID
"Style E/P Compr"	Limit Switch	TB1-64	10.0 sec	Digital (Paddle Type)	25 PSID
"Style F/GH Compr"	Limit Switch	TB1-64	3.5 sec	Programmable (Analog or Digital)	35 PSID
"Style F/J Compr"	Probe	TB1-64	3.5 sec	Programmable (Analog or Digital)	35 PSID
"Style F/P, Compr"	Limit Switch	TB1-64	10.0 sec	Programmable (Analog or Digital)	25 PSID

* Not applicable to Style C and earlier chillers

FLASH MEMORY CARD VERSION C.MLM.01.08.105A AND C.MLM.01.08.206A (AND LATER)

Chiller Style/Compressor	Proximity Sense	Oil Heater Output*	Level Control Period Default	Flow Switch	"Oil-Variable Speed Pump Pressure Setpoint Not Achieved" Threshold*
"Style CDE/GHJ Compr"	Probe	TB1-34	3.5 sec	Digital (Paddle Type)	35 PSID
"Style E/P Compr"	Limit Switch	TB1-64	10.0 sec	Digital (Paddle Type)	25 PSID
"Style F/G, H5-8 Compr"	Limit Switch	TB1-64	3.5 sec	Programmable (Analog or Digital)	35 PSID
"Style F/J, H3 Compr"	Probe	TB1-64	3.5 sec	Programmable (Analog or Digital)	35 PSID
"Style F/P, Compr"	Limit Switch	TB1-64	10.0 sec	Programmable (Analog or Digital)	25 PSID

* Not applicable to Style C and earlier chillers

SOFTWARE VERSION C.MLM.01.10B.XXX (AND LATER) OR C.OPT.01.10B.XXX AND LATER)

Chiller Style/Compressor	Proximity Sense	Oil Heater Output*	Level Control Period Default	Flow Switch	"Oil-Variable Speed Pump Pressure Setpoint Not Achieved" Threshold*
"Style CDE/GHJ Compr"	Probe	TB1-34	3.5 sec	Digital (Paddle Type)	35 PSID
"Style E/P Compr"	Limit Switch	TB1-64	10.0 sec	Digital (Paddle Type)	25 PSID
"Style F/G, H5-8 Compr"	Limit Switch	TB1-64	3.5 sec	Programmable (Analog or Digital)	35 PSID
"Style F/J, H3 Compr"	Probe	TB1-64	3.5 sec	Programmable (Analog or Digital)	35 PSID
"Style F/P, Q LH9 Compr"	Limit Switch	TB1-64	10.0 sec	Programmable (Analog or Digital)	35 PSID

SOFTWARE VERSION C.OPT.01.16.XXX (AND LATER)

Chiller Style/ Compressor	Proximity Sense	Oil Heater Output*	Level Control Period Default	Flow Switch	“Oil-Variable Speed Pump Pressure Setpoint Not Achieved” Threshold*	Standard Coastdown Time
“Style CDE/GHJ Compr”	Probe	TB1-34	3.5 sec	Digital (Paddle Type)	35 PSID	Programmable 150-900 sec
“Style E/P Compr”	Limit Switch	TB1-64	10.0 sec	Digital (Paddle Type)	25 PSID	Programmable 150-900 sec
“Style F/G, H5-8 Compr”	Limit Switch	TB1-64	3.5 sec	Programmable (Analog or Digital)	35 PSID	Programmable 150-900 sec
“Style F/J1-J5H3 Compr” “Style G/K1-K4 Compr”	Probe	TB1-64	3.5 sec	Programmable (Analog or Digital)	35 PSID	Programmable 150-900 sec
“Style F & G/PQH9 Compr”	Limit Switch	TB1-64	10.0 sec	Programmable (Analog or Digital)	35 PSID	Programmable 150-900 sec
“Style F/J7 Compr” “Style G/K6-K7 Compr”	Probe	TB1-64	3.5 sec	Programmable (Analog or Digital)	35 PSID	Programmable 240-900 sec

Enter the appropriate chiller/compressor combination as follows:

- 1 At the Keypad, login at SERVICE access level using password 1 3 8 0.
- 2 Select SETPOINTS/SETUP/OPERATIONS Screen.
- 3 Press the CHILLER STYLE/COMPRESSOR key.
- 4 Use ◀ or ▶ keys to select the appropriate chiller style/compressor combination. Default is “Style F/G,H5-8 Compr”.
- 5 Press ENTER (✓) key.

FLOW SWITCH

(Flash Memory Card version C.MLM.01.08.xxx and later)

Style E (and earlier) chillers are supplied with Paddle type flow sensors. Style F (and later) chillers are supplied with factory mounted Thermal type flow sensors. The Paddle type sensors are connected to the I/O Board 115Vac digital inputs TB4-12 (evaporator) and TB4-11 (condenser). The Thermal type sensors are connected to either J7 or J14 on the Microboard, depending on the vintage of the chiller. On new production chillers prior to June 2009, they are provided connected to the Microboard J7 (FIG. 12A). On new production chillers after June 2009, they are provided connected to the Microboard J14 (FIG. 12B).

In order for the program to read the correct flow sensor input, the FLOW SWITCH setpoint on the OPERATIONS Screen must be set appropriately in the procedure below. The correct setting is determined by the software version and the actual flow sensor connection point to the Optiview Control Center as follows:

With software version C.OPT.01.20.307 (and earlier), supplied prior to June 2009, the selections are ANALOG or DIGITAL. Select ANALOG when the Thermal type flow sensors are connected to the Microboard J7 (ref FIG. 12A). Select DIGITAL when the Paddle type sensors are connected to the I/O Board TB4 (ref FIG. 14).

With software version C.OPT.01.21.307 (and later), supplied after June 2009, the selections are J7, J14 or TB4. Select J7 when the Thermal type flow sensors are connected to the microboard J7 (ref FIG. 12B). Select J14 when the Thermal type sensors are connected to the Microboard J14 (ref FIG. 12B). Select TB4 when the Paddle type sensors are connected to the I/O Board TB4 (ref FIG. 14) and the Heating Condenser Water Paddle type flow sensor is connected to the LTC I/O Board J20 (if equipped with the Heat Recovery option; ref FIG. 66).

After the selection is made, the program will read the flow sensor input at the selected connection point and ignore the other connection points.

Enter the applicable flow sensor type as follows:

1. Select SETPOINTS/SETUP/OPERATIONS Screen.
2. Press FLOW SWITCH key.
3. Use ◀ or ▶ keys to make selection. Each time the key is pressed, the selections are alternately displayed
4. Press ENTER (✓) key.

MICROBOARD 031-02430-000/-001 SETUP/ CONFIGURATION

The following functions are programmed as Setpoints on the 031-02430-000/-001 microboard. Refer to SECTION 3A for explanation of each setpoint.

- Chilled Liquid Pump Operation
- Motor Drive Type
- Anti-recycle
- Power Failure Restart
- Coastdown
- Pre-Run
- Oil Pump Package
- Motor Communications Protocol (Only appears when VSD-50Hz, VSD-60Hz or SSS-Mod B is elected as Motor drive Type setpoint above. Applicable to Microboard 031-02430-001 with software version C.OPT.01.16.307 (or later) for VSD applications and C.OPT.01.18.307 (or later) for LCSSS applications)
- Motor Node ID (Only appears when MODBUS selected as Motor Communications Protocol above)
- Coastdown Time (software version C.OPT.01.16.307 and later)
- Condenser Temperature Range (software version C.OPT.01.19.307 and later)(Only appears when set to “Extended”, using an ADMIN password)
- PRV Position-enable/disable (software version C.OPT.01.21.307 (and later)
- Heat recovery-enable/disable (software version C.OPT.01.21.307 (and later)
- Head Pressure Control-enable/disable (software version C.OPT.01.21.307 (and later)

Program the above setpoints as follows:

1. At the Keypad, login at SERVICE access level using access code 1 3 8 0. (“Power Failure Restart” only requires OPERATOR access level 9 6 7 5). (“Motor Drive Type” requires chiller to be stopped with Compressor Switch in the Stop-Reset position).
2. Select SETUP Screen from SETPOINTS Screen.
3. Press CHANGE SETTINGS key.
4. A green box will appear around the first changeable setpoint. Use ▲ ▼ keys to place the box around the setpoint to be changed.
5. Press ✓ key. A dialog box will appear with the range of settings.
6. Use ◀▶ keys to scroll to desired setting.
7. Press ✓ key.

VARIABLE GEOMETRY DIFFUSER

(Applicable to chillers equipped with Variable Geometry diffuser only. Requires Software version C.MLM.01.10.xxx (and later) or C.OPT.01.10.302 (and later))

A complete description of the Variable Geometry Diffuser (VGD) operation and setpoints that affect this control is detailed in Section 22A of this book. The setpoints are listed below. If the compressor is equipped with this feature, it must be enabled and the setpoints programmed using the procedure below. Otherwise, it must be disabled. The VGD can be manually controlled using the procedure below. If the chiller is equipped with the compressor motor Variable Speed Drive or the optional Hot Gas Bypass, the Pre-rotation Vanes (PRV) calibration is performed per procedures applicable to those features listed elsewhere in this section. Otherwise, the PRV must be calibrated per the procedure below.

Enable/Disable:

If the compressor is equipped with the VGD, it must be Enabled. Otherwise it must be Disabled. Use the following procedure:

1. Shutdown chiller and place COMPRESSOR start/ Stop Switch in the Stop-reset position.
2. At the keypad, log in at SERVICE access level, using password 1 3 8 0.
3. Select SETPOINTS/SETUP/OPERATIONS screen.

4. Use ◀ and ▶ keys to select Enable or Disable as required.
5. Press ENTER (✓) key.

VGD Count:

The VGD Count is displayed on the VGD Screen. It is the number of times the Stall detector Board output goes above the High Limit setpoint. This count can be cleared as follows:

1. At the keypad, log in at ADMIN access level.
2. Select COMPRESSOR/VGD/VGD SETPOINTS Screen.
3. Using numeric keypad keys, enter desired number.
4. Press ENTER (✓) key.

Setpoints:

The following are the Setpoints and range of programmable values. The DEFAULT value is shown in parentheses. The default value is the recommended value and should provide proper operation in most applications. However, the Setpoint can be programmed to other values to compensate for local operating conditions. Use the following procedure:

- a. Surge Reaction Time - 1 to 30 seconds (5)
 - b. PRV Offset – 0 to 5% (3)
 - c. Probe Wait Time – 0.5 to 15 minutes (10)
 - d. Open Pulse – 1 to 9 seconds (2)
 - e. High Limit – 0.5 to 1.2Vdc (0.8)
 - f. Low Limit – 0.4 to 0.8Vdc (0.6)
 - g. Extreme Stall Duration – 10 to 20 minutes (10)
(Software version C.MLM.01.14.xxx (and later) or C.OPT.01.14.306 (and later))
 - h. PRV VGD Inhibit – 40% to 100% (95%)
(Software version C.MLM.01.14.xxx (and later) or C.OPT.01.14.306 (and later))
1. At the keypad, log in at Service access level using access code 1 3 8 0.
 2. Select COMPRESSOR/VGD/VGD SETPOINTS Screen.
 3. On the VGD SETPOINTS Screen, press the appropriate key to select the setpoint to be programmed.
 4. Using the numeric keypad keys, enter the desired value.

5. Press ENTER (✓) key.

Manual Control:

The VGD can be manually controlled as follows:

1. At the keypad, log in at Service access level using access level code 1 3 8 0.
2. Select VARIABLE GEOMETRY DIFFUSER Screen from the COMPRESSOR Screen.
3. On the VARIABLE GEOMETRY DIFFUSER Screen, press the OPEN, CLOSE or HOLD key as desired. Each time the OPEN or CLOSED key is pressed, the respective output is energized for 2 seconds and the respective LED illuminates for 2 seconds. Pressing the HOLD key causes the HOLD LED to illuminate and the VGD to be held in its present position with. Pressing the AUTO key invokes automatic operation.

Pre-rotation Vanes Calibration:

Refer to the Pre-rotation Vanes Calibration Procedure in this Section.

Pre-rotation Vanes Calibration

There is one procedure for all Pre-rotation Vanes (PRV) calibrations. The following procedure applies to the compressor motor Variable Speed Drive (VSD), Hot Gas Bypass, Variable Geometry Diffuser and any other PRV calibration.

1. Place the COMPRESSOR switch in the Stop-reset position (O) and wait until the System Coastdown is complete.
2. At the keypad, login at Service access level.
3. Select the PRE-ROTATION VANES CALIBRATE screen from the COMPRESSOR screen.
4. The pot should be initially set so that the feedback at the fully closed PRV position is 0.3vdc to 0.7vdc. Press the START CALIBRATION key to initiate the calibration. The CALIBRATION IN PROGRESS and PRV OPENING LED will illuminate and an open signal is applied to the PRV. After a 60 second delay, the program begins evaluating the feedback voltage from the PRV potentiometer. When the feedback voltage stops increasing and remains stabilized (so that there is no more than ± 0.025 vdc deviation) for 25 continuous seconds, the feedback voltage is logged as the 100% position. A close signal is then applied to the PRV and illuminates the PRV CLOSING LED. After a 10 second delay, the program begins evaluating the feedback voltage from the PRV potentiometer.

When the feedback voltage stops decreasing and remains stabilized (so that there is no more than ± 0.025 vdc deviation) for 25 continuous seconds, the feedback voltage is logged as the 0% position. These endpoint voltages are stored in the BRAM as the full open and full closed positions.

- If the difference between the endpoint voltages is greater than 0.5vdc, “PRV Calibration Successful” is displayed. Otherwise, “PRV Calibration Unsuccessful” is displayed. Also, if the endpoints are not established within 10 minutes, “PRV Calibration Unsuccessful” is displayed.

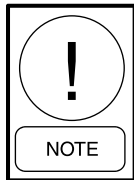

The calibration procedure can be terminated at any time during the procedure by pressing the CANCEL CALIB key. If the PRV were previously calibrated successfully, it will revert to using the previous calibration values. If they were not previously calibrated successfully, they will remain uncalibrated.

High Condenser Pressure Fault While Shutdown – reset procedure

(Software version C.MLM.01.14.xxx (and later) or C.OPT.01.14.306 (and later))

High temperature condenser water flowing through the condenser while the chiller is shutdown can cause a condenser high pressure condition in the condenser resulting in loss of refrigerant. This anticipatory safety fault annunciates condenser high pressure conditions when the chiller is not running as follows:

While the chiller is stopped, if the condenser pressure exceeds 160.0 PSIG (R134a), 240.0 PSIG (R22), a safety fault occurs and “Condenser – High Pressure - Stopped” is displayed. The chiller can be started after the condenser pressure decreases to less than 160.0 (R134a), 240.0 PSIG (R22) and a special reset procedure is performed as follows:

- Place the COMPRESSOR switch in the Stop-reset position.
- At the keypad, login at Service access level using code 1 3 8 0.
- Select CONDENSER screen.
- Press the FAULT ACKNOWLEDGE key on the CONDENSER Screen. A dialog box appears displaying “Enter Password to Clear Fault”.
- Enter 1 3 9 7 and press the ENTER key (✓).

This anticipatory fault is only performed while the chiller is stopped. If a “Condenser – High Pressure” fault is detected while the chiller is in Pre-lube, System Run or Coastdown, the fault is handled in the normal way and does not require the special reset procedure.

MOTOR LUBRICATION NOTIFICATION

This feature provides an indication when the compressor motor lubrication is required. The lubrication requirement and notification is based on the “Operating Hours Since Last Motor Lubrication”.

There are up to three levels of notification, each indicating an increasing level of urgency. “Warning – Motor Bearing Lube Suggested” is displayed when the hours exceed 1000 hours. If there is no response, “Warning – Motor Bearing Lube Required” is displayed when the hours exceed 1200 hours. If there is still no response, a safety shutdown is performed when the hours exceed 1400 hours and “Motor – Lack of Bearing Lubrication” is displayed.

To provide a record of when a motor lubrication is performed, the Operator enters his/her initials, name or user ID using the Motor Lube Acknowledge key on the Motor Lubrication Screen. The date and time of this entry is automatically logged as the Date of Last Lubrication and Time of Last Lubrication. This also clears any motor lubrication warning or safety that is in effect and resets the Operating Hours Since Last Lubrication to zero.

The Motor Lubrication Screen, accessible from the Motor Screen in any access level, displays information applicable to this feature.

When both motors have been lubricated, the Operator must acknowledge the lubrication has been performed. This is done by entering his/her initials, name or user ID as a 3 to 8 character string. The entry is displayed as the Operator Initials at Last Lubrication. The date and time of this entry is automatically logged as the Date of Last Motor Lubrication and Time of Last Motor Lubrication. This entry also resets the Operating Hours Since Last Lubrication to zero.

This entry also resets the motor lubrication warning messages: “Warning – Motor Bearing Lube Suggested”, “Warning – Motor Bearing Lube Required” and safety shutdown “Motor – Lack of Bearing Lubrication”.

Enter your initials, name or user ID using the following procedure. The entry must be a minimum of 3 characters and a maximum of 8 characters.

1. At the keypad, log in at OPERATOR access level using Password 9 6 7 5. If resetting the safety shutdown “Motor – Lack of Lubrication”, place COMPRESSOR switch in Stop-reset (O) position.
2. Press the Motor Lube Acknowledge key. A dialog box appears. A red box highlights the first changeable location.
3. Use the ▲▼ keys to scroll sequentially through the alphabet to enter letters or numbers. Each time the ▲ is pressed, the next higher sequential alphabet letter or number is displayed. Each time the ▼ is pressed, the next lower alphabet letter or number is displayed. When the desired letter or number is displayed, use the ► key to forward space the red box for the next entry. Use the ◀ key to backspace, if necessary.

To write over an existing entry or to place a blank space, scroll to the beginning of the alphabet. The selection prior to the letter “A” is a blank space. Use the • key to enter a period/decimal point. During the entry process, if it is desired to exit the dialog box and retain the previous entry, press the CANCEL (X) key.

4. When all of the desired characters have been entered, press the ENTER (✓) key.

Motor Lube Date:

Normally, the Date of Last Lubrication is automatically recorded when the Operator enters his/her initials, name or user ID with the Motor Lube Acknowledge key in the above procedure. However, if it is necessary to modify the motor lubrication date after that procedure was performed, proceed as follows:

1. At the keypad, login at ADMIN access level.
2. Press the Motor Lube Date key.
3. Using the number keys, enter the desired date.
4. Press the ENTER (✓) key.

Software version C.OPT.01.16.xxx (and later) adds the AUTO LUBE and SHUTDOWN setpoints to the Motor Screen:

The AUTO LUBE Setpoint accommodates those chillers that are equipped with Automatic Motor Lubrication hardware that automatically lubricates the motor. Since chillers that are equipped with Automatic Motor Lubrication hardware don't require manual lubrication, the motor lubrication warnings (reminders) and safety shutdown are unnecessary. Therefore, when the

automatic lubrication hardware is present, the AUTO LUBE Setpoint must be ENABLED. With this setting, no lubrication warnings or shutdown will occur.

If the AUTO LUBE setpoint is DISABLED, as it should be when not equipped with the Automatic Motor Lubrication hardware, the motor lubrication warnings and shutdown will occur at the associated elapsed run times. With this setting, the SHUTDOWN Setpoint can be used to enable or disable the safety shutdown that occurs at 1400 hours since last lubrication. The safety shutdown can be enabled or disabled per the customer's preference. If enabled, the safety shutdown will occur at the normal 1400 hours. If disabled, a warning will be displayed but the safety shutdown will not occur.

Use the following procedure:

1. At the keypad, login at SERVICE Access level using Access Level 1 3 8 0.
2. From the MOTOR Screen, select the MOTOR LUBE Screen.
3. Press the AUTO LUBE key.
4. Use the ◀ and ► keys to select Enable or Disable as desired per above.
5. Press ENTER key.
6. If Disable is selected in step 4, press the SHUTDOWN key.
7. Use the ◀ and ► keys to select Enable or Disable as desired per above.
8. Press ENTER key.

QUICK START

(Software version C.OPT.01.21.307 and later)

The Quick Start feature is useful in data center and process control applications where it is desirable to re-establish cooling as fast as possible after a shutdown or power failure. This feature, when enabled, allows quicker starts and restarts than normal by reducing the cycle time and once running, loading the chiller as fast as possible. By default, this feature is disabled. It must be enabled to use it. A complete explanation of this feature and the following setpoints is contained in Section 26 of this manual.

- Quick Start Enable
- Quick Pulldown Setpoint Offset
- Pulldown Override Time
- VSD Start Frequency
- Mapping Enable
- Quick ramp Current Threshold

This feature can only be enabled if the Motor Drive Type setpoint is set to MV VSD or VSD (and the Motor Communications Protocol Setpoint is set to MODBUS). It requires an ADMIN password to change. When logged in at ADMIN level, a QUICK START key appears on the SETPOINTS Screen. Pressing this key will navigate to the QUICK START Screen where the QUICK START MODE setpoint is used to enable/disable this feature as follows:

1. At the keypad, log in at ADMIN access level using an ADMIN password.
2. Select QUICK START screen from the SETPOINTS screen
3. Press CHANGE SETPOINTS key
4. A green box will appear around the Quick Start Mode setpoint.
5. Press the Checkmark key. A dialog box will appear allowing enable/disable of the feature
6. Use the ◀ and ▶ keys to select Enable.
7. Press the Checkmark (✓) key.

Once enabled, the Quick Start setpoints can be changed using the following procedure.

1. At the keypad, login at SERVICE access level using access code 1380.
2. Select QUICK START from the SETPOINTS Screen.
3. Press CHANGE SETPOINTS key
4. A green box will appear around the first changeable setpoint. Use the UP/DN arrow keys to place the box around the setpoint to be changed.
5. Press the Checkmark key.
6. Use the ◀ and ▶ keys to select the desired setting.
7. Press the Checkmark (✓) key.

SECTION 28

DIAGNOSTICS & TROUBLESHOOTING

The problems that could be encountered in the OptiView Control Center are in the following categories:

- Keypad
- Display
- Serial Input/Output (I/O)
- Digital Input/Output (I/O)
- Analog Inputs

There is a Diagnostic and associated Troubleshooting procedure for each category. They are described on the following pages. Each Diagnostic is accessed from the Diagnostics Main Screen, which is entered using the procedure below. If there is an OptiView Control Center problem, determine the category of the problem. Then perform the applicable Diagnostic. If the Diagnostic reveals a malfunction, perform the Troubleshooting procedure to locate the defective component.

There are several documents that must be referred to while performing the Diagnostics and Troubleshooting procedures. Each procedure references the Section and figures of this book that describe the operation of the component being tested. Also, the applicable OptiView Control Center wiring diagram must be used as listed in the REFERENCE INSTRUCTIONS section at the front of this book.

There are two versions of the Diagnostics screens available as follows:

1. Shown in FIG 72 through 81. These screens are used during the Diagnostics and Troubleshooting process. They allow output states to be changed. Access the Diagnostics Main Screen as follows:
 - a. The chiller must be stopped.
 - b. Place Compressor Start/Stop switch in the Stop-Reset position (O).
 - c. Ensure the Compressor motor current is 0% FLA.
 - d. Log in at **SERVICE** access level using access code **1 3 8 0**.
 - e. Move Microboard Program Switch SW1-4 (microboard 031-01730-000); SW1-3 (microboard 031-02430-000 or 031-02430-001) to the ON position. A Watchdog reset will occur and the Boot-up process will commence. At the completion of the Boot-up process, the Diagnostics Main Screen will appear. (Note: if the Program Switch is moved to the ON position before step 4 above is performed, the **LOG IN** key will be displayed and Logging in at **SERVICE** access level must be performed before the Main Screen is displayed.
2. Not shown. Available when logged in at **SERVICE** access level, whether the chiller is running or not. Accessed from the **SETUP** screen via the **SETPOINTS** screen. There are two screens available that allow the Analog Inputs voltage levels and Digital I/O states to be monitored. These screens are preceded by a general screen that provides the installed software versions.

DIAGNOSTICS SCREEN



FIG. 72 – DIAGNOSTICS SCREEN

LD14327

This screen shows all of the software that is loaded onto the microboard and the motor starter connected to the microboard via serial communications.

Controls – Software that controls the chiller. On 031-02430-000 microboards, the program resides in the Flash Memory Card (U46). On 031-02430-000/001 microboards, the program resides in the non-removable flash memory chip (U35).

BIOS – BIOS eeprom on microboard

Kernel – software that is part of flash memory

GUI – Software that is part of the flash memory

SIO – software that is part of flash memory

GPIC – eeprom in Microgateway

SSS, VSD, MVSSS or MVVSD – software that is in the respective device

MAIN DIAGNOSTICS SCREEN

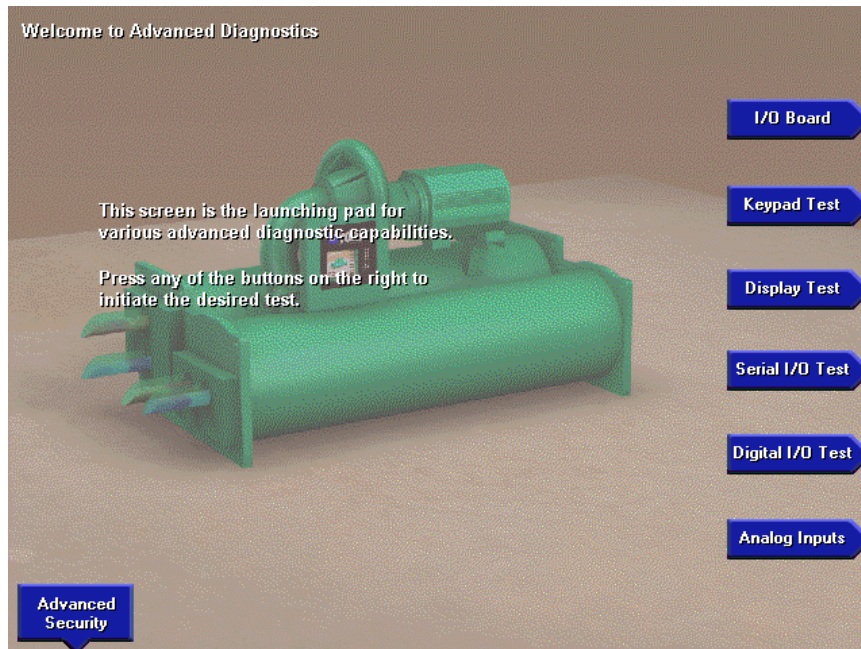

FIG. 73 – MAIN DIAGNOSTICS SCREEN

LD14328

Each of the Diagnostics is accessed from this screen. Press the appropriate key to select the desired diagnostic. After each diagnostic is performed, return to this **MAIN** Screen, from which the next diagnostic can be selected.

Some of the diagnostics have sub-screens that are accessed from the selected diagnostic screen. The sub-screens are shown indented below:

Main screen

- I/O Board (software version C.OPT.01.21.307 and later)
- Keypad test
- Display test
 - Bit patterns test
 - All red
 - All green
 - All blue
 - All white
 - All black
- Serial I/O test
- Digital I/O test
- Analog Inputs

The **ADVANCED SECURITY** key is used during the manufacturing process and has no field service use.

I/O BOARD (031-02895-000) DIAGNOSTIC SCREEN

(Software version C.OPT.01.21.307 and later)

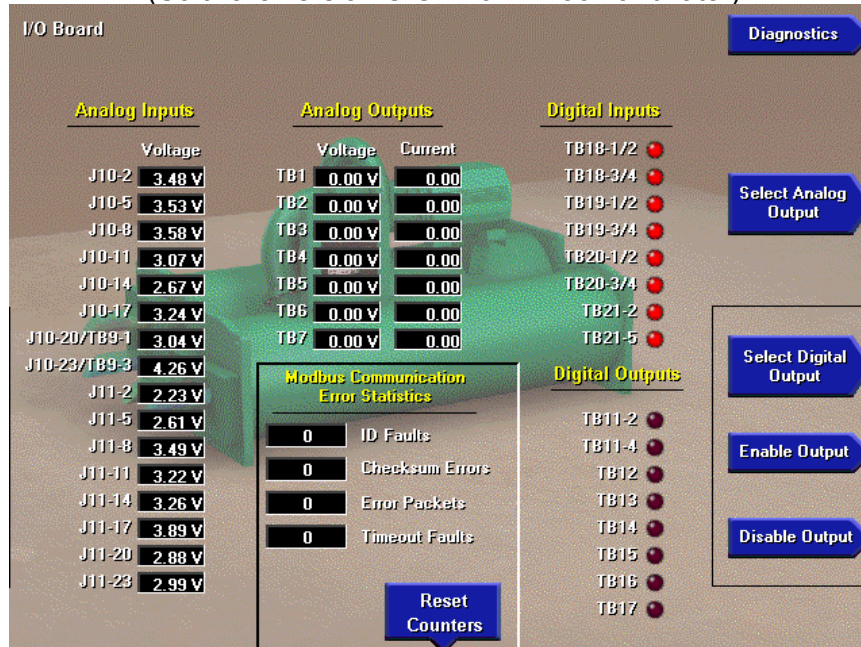

FIG. 74 – I/O BOARD DIAGNOSTIC SCREEN

LD14329

This diagnostic Screen is used to analyze the analog and digital inputs and outputs of I/O Board 031-02895-000. The outputs can be manually set to a desired level from here. Also, serial communications error statistics are displayed here. Refer to description of this board in SECTION 23 of this manual.

ANALOG INPUTS

The voltage level of each analog input at the indicated input terminals is displayed as x.xxVdc.

ANALOG OUTPUTS

The analog outputs are in the form of 0-10Vdc or 0-20mA at each of the listed connectors. The values displayed are the values the I/O Board is intending to provide at the output connector. The voltage output is at terminal 2 of each output connector and is displayed as x.xxVdc. The current output is at terminal 1 of each output connector and is displayed as xx.xxmA.

The voltage value and the current value are directly scaled over their respective ranges of 0-10Vdc and 0-20mA. For example, when the voltage output (terminal 2) is at 0Vdc, the current output (terminal 1) is at 0mA. A 10Vdc output produces a 20mA output. A 5Vdc output produces a 10mA output, etc.

To test an output, each output can be manually set to any desired value within its range limits. The desired value is set in terms of a voltage value. For example, if the voltage is set to 5Vdc, the current value will automatically be set to 10mA. When Diagnostic Mode is exited (DIP Switch 3 is set back to OFF position), outputs revert to program control.

To manually set the output:

1. Press the SELECT ANALOG OUTPUT Key, A green box will be placed around the first changeable output.
2. Use the keypad UP and DOWN arrow keys to place the green box around the desired output.
3. Press the CHECK MARK Key. A box will appear showing the range of allowed voltage values.
4. Using the Keypad keys, enter the desired voltage value.
5. Press the CHECK MARK Key. The entered voltage value and corresponding current value will be shown in the selected output box. The voltage value is at terminal 2 of the selected output. The current value is at terminal 1 of the selected output.

DIGITAL INPUTS

The state of each digital input is directly depicted by an LED. When the input is high (1250Vac or +5Vdc), the LED is illuminated). Otherwise, it is extinguished.

DIGITAL OUTPUTS

The state of each output is depicted by an LED. When the output is ON, it is illuminated. Otherwise, it is extinguished.

To test an output, each output can be manually set to ON or OFF. The motor controller circuit must be opened before manual control is allowed. Removing J2 from the I/O Board opens this circuit. When Diagnostic mode is exited (DIP Switch 3 is set back to the OFF position), outputs revert to program control.

To manually set the output:

1. Press SELECT DIGITAL OUTPUT Key. A yellow arrowhead will appear to the right of the first digital output.
2. Use the UP and DOWN arrow keys to place the arrowhead at the desired output.
3. Press ENABLE OUTPUT key to turn the output on. Press the DISABLE OUTPUT key to turn the output off.

MODBUS COMMUNICATION ERROR COUNTERS

The following error counts are displayed:

- ID Faults
- Checksum Errors
- Error Packets
- Timeout Faults

Press the RESET ERROR COUNTERS key to reset these counters to zero.

KEYPAD TEST

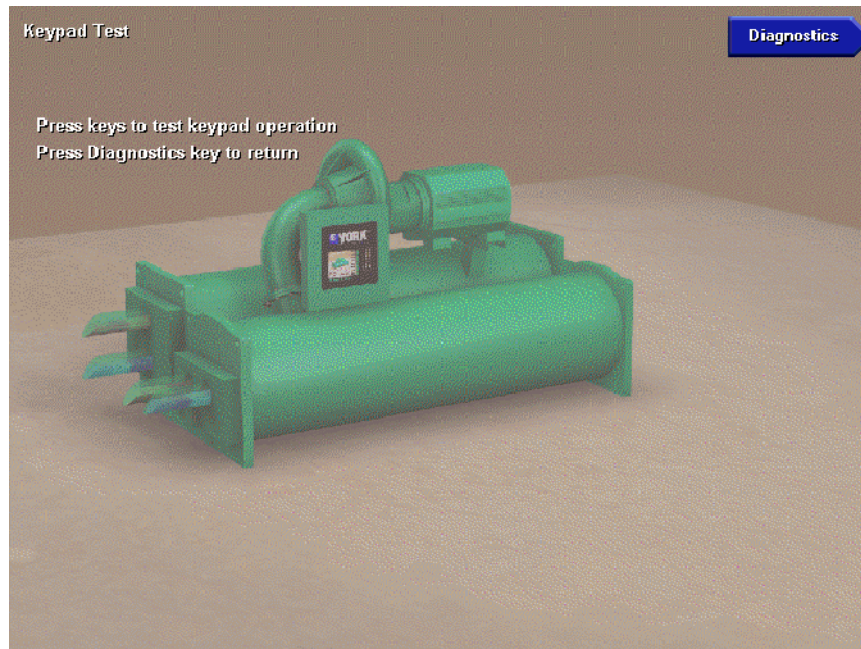

FIG. 75 – KEYPAD TEST SCREEN

00336VIP

This diagnostic is used to verify Keypad operation and the Microboard's ability to respond to a pressed key. Refer to description of Keypad operation in Section 8 of this book.

PROCEDURE

1. Press each keypad key. As the key is pressed, an illuminated LED is displayed corresponding to the key location on the keypad.
2. Press the **DIAGNOSTICS** key to return to the **MAIN DIAGNOSTICS** Screen.

TROUBLESHOOTING

If an LED is not displayed when a key is pressed, the Keypad, Keypad Ribbon Cable or Microboard could be defective. Use the following procedure to locate the defective component.

1. Keypad

- a. Disconnect the Ribbon Cable from the Keypad.
- b. Identify row/column coordinate of the key to be tested. Refer to FIG. 33.

- c. In the Keypad connector, locate the pins of the row/column coordinate of the key of the key to be tested.
- d. Insert the leads of an Ohmmeter into the pins identified in step "c" above.
- e. Press the key to be tested. If the contact resistance is >100 Ohms, the Keypad is defective.
- f. Release the key. If the contact resistance is < 1 Meg Ohm, the Keypad is defective.

2. Ribbon Cable

Using an Ohmmeter, perform a continuity test on all conductors in the ribbon cable. An open circuit would indicate the Ribbon Cable is defective.

3. Microboard

There are no checks or measurements to be made on the Microboard. If the Keypad and Ribbon Cable check OK per the above procedures, the Microboard is most likely the cause of the problem.

DISPLAY TEST

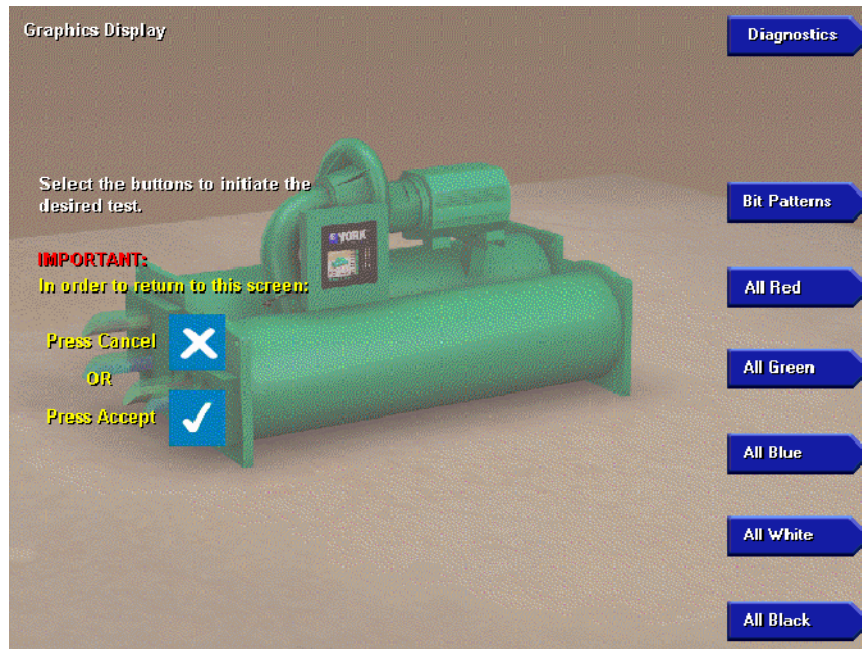

FIG. 76 – DISPLAY TEST MAIN SCREEN

Each of the Display Diagnostics is accessed from this screen. After each diagnostic is performed, return to this screen, from which the next diagnostic can be selected. Refer to description of Display operation in Sections 5 through 7 of this book.

PROCEDURE

1. Press the appropriate keypad key to perform the desired test from the list below.
 2. Press the **CANCEL (X)** or **ENTER (✓)** key to terminate test and return to **DISPLAY TEST MAIN** screen, from which another test can be selected.
 3. When all the desired tests have been performed, press the **DIAGNOSTICS** key to return to the **MAIN DIAGNOSTICS** screen.
- **Bit Patterns** - This test is used to detect jitter and alignment defects. It verifies proper operation and compatibility of the Microboard Display Controller with the display. Four vertical bars of green, dark blue, light blue and yellow, outlined by a red border are displayed. If the vertical bars are not stable or straight, or the red border is not completely visible, then either the Microboard Program Jumpers are not configured correctly for the installed display or the Microboard Display controller is defective. Refer to FIG. 66.
 - **All Red** - This test verifies the operation of all of the red pixels. All of the red pixels are turned on to create a completely red screen. Any red pixels

that do not turn on will appear as black dots on the display. If any black dots appear, first ascertain it is not caused by dirt that is lodged between the display surface and the protective plastic cover. It is normal for a small number of randomly spaced pixels to not illuminate. It is not necessary to replace the display if a small number of black dots appear. They will not be visible on the normal screens displayed outside of this diagnostic mode. However, large black areas would be indicative of a defective display.

- **All Green** - This test verifies the operation of all of the green pixels. All of the green pixels are turned on to create a completely green screen. Refer to description of “All Red” test above.
- **All Blue** - This test verifies the operation of all of the blue pixels. All of the blue pixels are turned on to create a completely blue screen. Refer to description of “All Red” test above.
- **All White** - This test verifies the display’s ability to turn on all pixels to display a completely white screen. Any pixel that does not turn on will appear as a black dot. Refer to description of “All Red” test above.
- **All Black** - This test verifies the display’s ability to turn off all pixels to display a completely black screen. Any pixel that does not turn off will appear as a red, green, blue or white dot. Refer to description “All Red” test above.

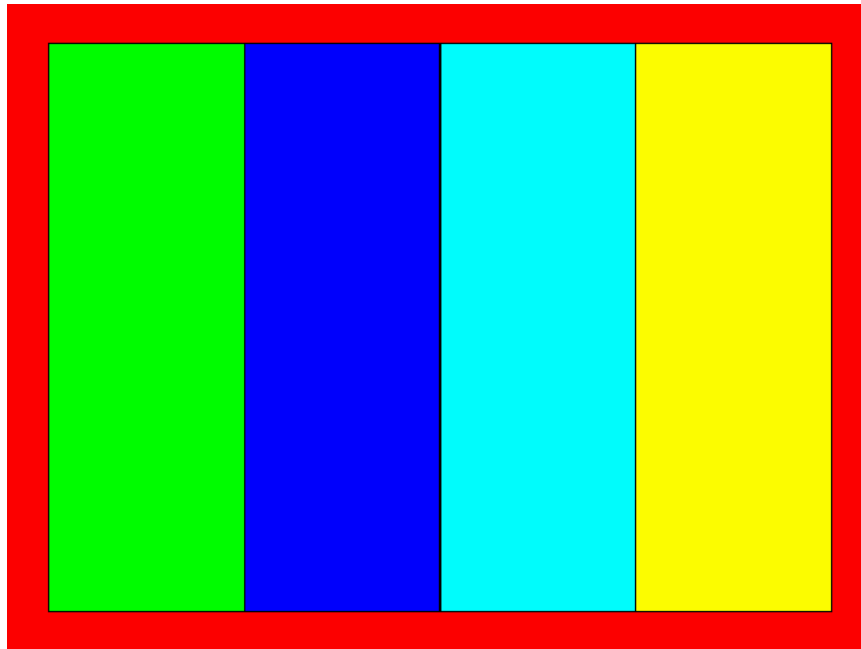

FIG. 77 – BIT PATTERNS TEST SCREEN

00338VIP

TROUBLESHOOTING

If any of the above tests do not perform correctly as described above, perform the applicable procedure below:

Test Failed:

Bit Patterns - If the vertical bars are not straight or if the red border is not completely visible, either the Microboard Program Jumpers are not configured correctly or for the installed Display or the Microboard is defective.

All Red, All Green, All Blue, All White or All Black:

If these tests do not produce appropriate solid color screens, the Display Ribbon Cable, Display Interface Board, Microboard or Display could be defective. To locate the defective component perform tests in the following order:

1. Display Ribbon Cable:

Using an Ohmmeter, perform a continuity test on all conductors in the ribbon cable. An open circuit would indicate the ribbon cable is defective.

2. Display Interface Board:

Using an Ohmmeter, perform a continuity test on all conductors of the Interface Board. An open circuit would indicate the Interface Board is defective.

3. Microboard:

- a. With the “All Red” test selected, the voltage at Microboard J5-6 through J5-11 (Red drivers bits 0-5), as measured to Gnd, should be $> 3.0\text{VDC}$. If not, the Microboard is defective.
- b. With the “All Green” test selected, the voltage at Microboard J5-13 through J5-18 (Green drivers bits 0-5), as measured to Gnd, should be $> 3.0\text{VDC}$. If not, the Microboard is defective.
- c. With the “All Blue” test selected, the voltage at Microboard J5-20 through J5-25 (Blue drivers bits 0-5), as measured to Grid, should be $> 3.0\text{VDC}$. If not, the Microboard is defective.
- d. With the “All White” test selected, the voltage at Microboard J5-6 through J5-11, J5-13 through J5-18 and J5-20 through J5-25 should be $> 3.0\text{VDC}$. If not, the Microboard is defective.
- e. With the “All Black” test selected, the voltage at Microboard J5-6 through J5-11, J5-13 through J5-18 and J5-20 through J5-25 should be $< 1.0\text{VDC}$. If not, the Microboard is defective.

4. Display:

If the Display Ribbon Cable, Display Interface Board and Microboard check OK per the above procedures, the Display is most likely the cause of the problem.

SERIAL INPUTS / OUTPUTS TESTS

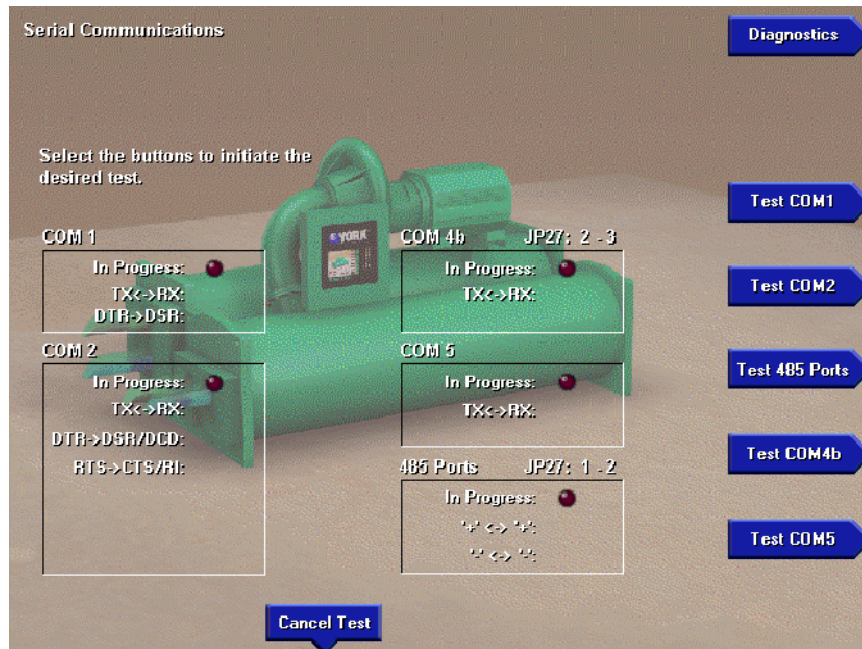

FIG. 78 – SERIAL INPUTS / OUTPUTS TEST SCREEN

00339VIP

This diagnostic is used to verify correct operation of the Serial Data Ports. There is a test for each of the five Serial Data Ports. Each RS-232 port (COM 1, 2 and 4b) is tested by transmitting serial test data from outputs to inputs of each port. Both the transmit and receive functions as well as the control lines are tested. The RS-485 ports (COM 3 and 4a) are tested by transmitting serial test data from one RS-485 port to another. The TX/RX opto-coupled port (COM 5) is tested by transmitting serial test data from the TX output to the RX input. If the received data matches the transmitted data, PASS is displayed, indicating the serial port is OK. Otherwise, FAIL is displayed, indicating the serial port is defective. Prior to performing each test, the Service Technician must install a wire loop-back connection as described below. Refer to Section 3 and FIG. 11 of this book for description of the Serial data Ports.

PROCEDURE

- Using small gauge wire, fabricate loop-back connections and install as follows for each port to be tested. Failure to install the loop-back connection or configure the Microboard Program jumper as noted will result in a FAIL outcome for the test.

	From	To
COM 1	J2-4 (TX)	J2-3 (RX)
	J2-5 (DTR)	J2-2 (DSR)

	From	To
COM 2	J13-5 (TX)	J13-3 (RX)
	J13-7 (DTR)	J13-1(DCD) & J13-2 (DSR)
	J13-4 (RTS)	J13-6 (CTS) & J13-8 (RI)

	From	To
RS-485 (COM 3 & 4a)	J12-3 (+)	J11-3 (+)
	J12-2 (-)	J11-2 (-)

Microboard Program Jumper JP27 must be installed in position 1 & 2.

	From	To
COM 4b	J2-7 (GTX)	J2-6 (GRX)

Microboard Program Jumper JP27 must be installed in position 2 & 3.

	From	To
COM 5	J15-1 (TX)	J15-4
	J15-2 (RX)	J15-5
	J15-3 (Common)	J15-6

Make individual wire connections or use YORK loop-around diagnostic connector 025-33778-000 as depicted in FIG. 68 This connector is available from the YORK Parts Distribution Center.

- After connecting appropriate loop-back connections above, press the appropriate key to initiate the desired test. An LED will illuminate indicating the test is in progress. If it is desired to terminate the test, press the CANCEL TEST key. Test data is sent from an output to an input as described below. At the completion of each test, if the data received matches the data sent, the Serial Port operates properly and PASS is displayed. Otherwise, FAIL is displayed, indicating the Serial Port is defective. A FAIL result would be indicative of a defective Microboard. The following is a description of each test.

COM 1 – Two tests are performed. Test data is sent from TX (J2-4) to RX (J2-3) at 9600 Baud and DTR (J2-5) is set to a Logic High level and read at DSR (J2-2). If any test fails, COM 1 tests are terminated.

COM 2 – Three tests are performed. Test data is sent from TX (J13-5) to RX (J13-3) at 19200 Baud.

DTR (J13-7) is set to a Logic High and read at DSR (J13-2) & DCD (J13-1). RTS (J13-4) is set to a Logic High and read at CTS (J13-6) & R1 (J13-8). If any test fails, COM 2 tests are terminated.

RS-485 (COM 3 & 4a) – Test data is sent from COM 3 RS-485 port to COM 4a RS-485 Port at 19200 Baud. Test data is then sent from COM 4a to COM 3 at the same rate. If either test fails, RS-485 tests are terminated.

COM 4b – Test data is sent from GTX (J2-7) to GRX (J2-6) at 19200 Baud.

COM 5 – Test data is sent from TX (J15-1) to J15-4 at 1200 Baud. This output turns the Microboard's loop-around test Transistor on and off, applying 0/+5VDC pulses from J15-5 to RX (J15-2) input.

- After all desired tests have been performed, press the **DIAGNOSTICS** key to return to the **MAIN DIAGNOSTICS** Screen.

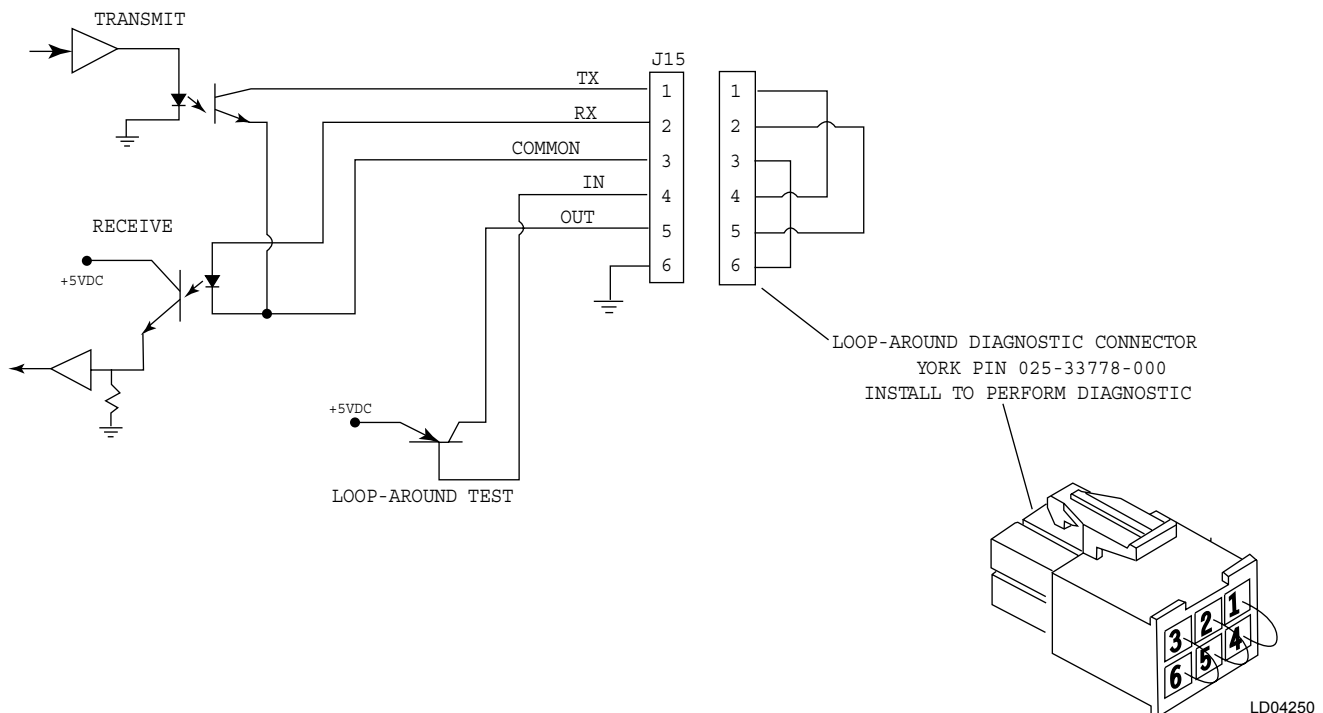

FIG. 79 – MICROBOARD - COM 5 SERIAL DATA PORT

DIGITAL INPUTS / OUTPUTS TESTS

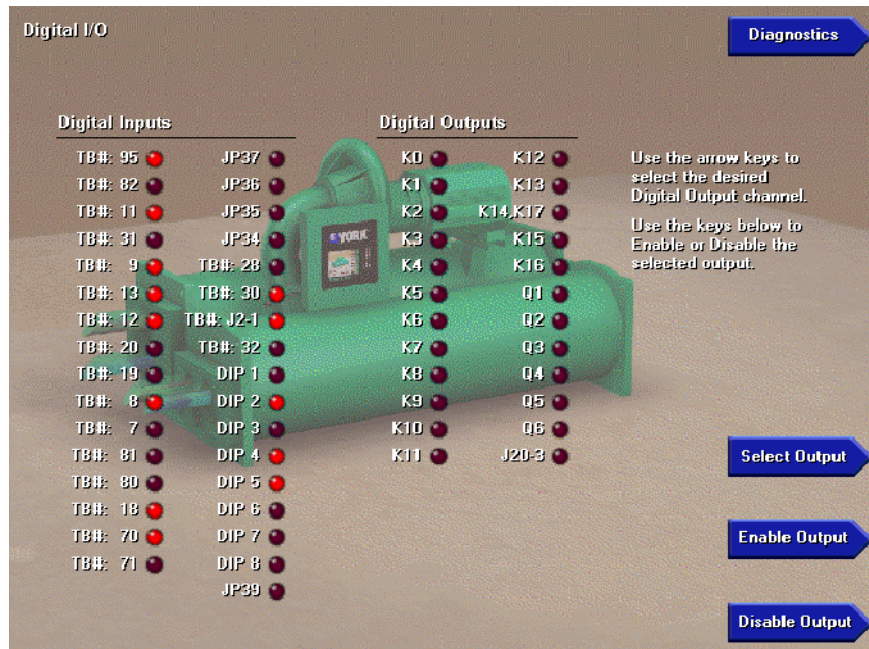

FIG. 80 – DIGITAL INPUTS / OUTPUTS TEST SCREEN

00340VIP

This diagnostic is used to analyze the digital inputs and outputs of the Microboard. Refer to description of I/O Board in Section 4 of this book.

The state of each Microboard Digital Input, Program Jumper and Program DIP Switch, as interpreted by the Microboard, is depicted by an LED. If the Microboard interprets its input as being at a Logic Low (<1.0VDC) level, the LED is illuminated. If interpreted as being at a Logic High (>4.0VDC) level, the LED is extinguished.

The state of the Microboard's intended drive signals to each of the Relays on the I/O Board is depicted by an LED. If the intended output is a Logic Low level (<1.0VDC), the LED is illuminated. If the intended output is a Logic High level (>10.0VDC), the LED is extinguished. Logic Low outputs energize the Relays. Logic High outputs de-energize the Relays. The state of any output can be manually set to either the ENABLED (Logic Low) or DISABLED (Logic High) state.

PROCEDURE

Digital Inputs:

1. The Digital Inputs are listed on this screen according to a.) Terminal number on the I/O Board and b.) Microboard Program Jumpers and Program

DIP Switches. FIG. 14 shows the devices connected to these terminals. Tables 1 and 2 list the functions of the Program Jumpers and Switches.

2. With 115VAC applied to a particular I/O Board Digital Input, the applicable LED should be illuminated. If the LED is not illuminated, perform appropriate Troubleshooting procedure below.
3. With 0VAC applied to a particular I/O Board Digital Input, the applicable LED should be extinguished. If the LED is not extinguished, perform appropriate Troubleshooting procedure below.
4. If a Program Jumper is present, the applicable LED should be extinguished. If the LED is not extinguished, the Microboard is defective.
5. If a Program Jumper is not present, the applicable LED should be illuminated. If the LED is not illuminated, the Microboard is defective.
6. If a Program Switch (DIP) is in the ON position, the applicable LED should be illuminated. If the LED is not illuminated, the Microboard is defective.
7. If the Program Switch (DIP) is in the OFF position, the applicable LED should be extinguished. If the LED is not extinguished, the Microboard is defective.
8. When all desired tests have been performed, press **DIAGNOSTICS** key to return to **MAIN DIAGNOSTICS** Screen.

Digital Outputs:

1. **IMPORTANT!** - The following steps cannot be performed until the Motor Controller connection between TB6-1 and TB6-53 has been removed. This connection could be a jumper or it could be a connection from external devices in the starter. The Program will prevent manual control of Digital Output devices until this connection is removed.
2. The Digital Outputs are listed on this Screen according to Relay and Triac number (KI, Q3, etc). FIG. 17 shows the external devices that are connected to these Relays and Triacs and the functions of each one.
3. Press **SELECT** key. An arrow will appear adjacent to Relay KO.
4. Select a relay or triac for manual control by using the ▲ and ▼ keys to place the arrow adjacent to the desired device.
5. Press the **ENABLE OUTPUT** key to enable the selected output. The LED adjacent to the selected output should illuminate. If it does not, perform **KEYPAD** Diagnostics test. If a relay is selected, it should energize, closing its contacts. If a triac is selected, it will turn on, energizing the device it is connected to. If the relay does not energize or triac does not turn on, perform appropriate troubleshooting procedure below.
6. Press the **DISABLE OUTPUT** key to disable the selected output. The LED adjacent to the selected output should extinguish. If it does not, perform **KEYPAD** diagnostic test. If a relay is selected, it should de-energize, opening its contacts. If a triac is selected, it will turn off, de-energizing the device it is connected to. If relay does not de-energize or triac does not turn off, perform appropriate troubleshooting procedure below.
7. When all desired tests have been performed, press **DIAGNOSTICS** key to return to the **MAIN DIAGNOSTICS** Screen.
8. Install Motor Controller connection from TB6-I to TB6-53 removed in step 1.

Digital Inputs Troubleshooting:

If any of the Digital Inputs tests fail to perform as described above, perform the following steps in sequence. Refer to FIG. 14 and applicable wiring diagram referenced at the beginning of Section 23. If a defective component is found during any of the following steps, replace the component as instructed and repeat the digital Inputs Procedure above to determine if the problem has been resolved.

1. Remove I/O Board ribbon cable. Using an Ohmmeter, perform a continuity check on I/O Board ribbon cable J1-21 to J19-21, J1-22 to J19-22 and applicable output pin of function that failed in Procedure above. If an open circuit is detected, replace ribbon cable. Otherwise, install ribbon cable and proceed to next step.
2. Measure the +5VDC supply voltage to the I/O Board on I/O Board between J1-21 and J1-22. If >4.5VDC, proceed to next step. If < 4.5VDC, disconnect ribbon cable at I/O Board J1 and repeat the measurement at J1. If <4.5VDC, replace the Microboard. Re-install the ribbon cable.
3. With 115VAC ($\pm 10\%$) applied to the I/O Board digital input that failed in Procedure above, the applicable I/O Board output at J1 should be at a Logic low level (<1.0VDC). If it is >1.0VDC, replace the I/O Board. If the output is at a Logic Low level, the applicable LED should be illuminated. If the LED is not illuminated, replace the Microboard.
4. With 0VAC applied to the I/O Board digital input that failed in Procedure above, the applicable I/O Board output at J1 should be at a Logic High level (>4.0VDC). If it is <4.0VDC, replace the I/O Board. If the output is at a Logic High level, the applicable LED should be extinguished. If it is not extinguished, replace the Microboard.

Digital Outputs Troubleshooting:

If any of the Digital outputs tests fail to perform as described above, perform the following steps in sequence. Refer to FIG. 17 and applicable wiring diagram referenced at the beginning of Section 23. If a defective component is found during any of the steps, replace the component as instructed and repeat the Procedure above to determine if the problem has been resolved.

1. Remove I/O Board ribbon cable. Using an Ohmmeter, perform a continuity test on the cable J1-25 to J19-25, J1-26 to J19-26 and applicable output pin of function that failed in Procedure above. If an open circuit is detected, replace ribbon cable. Otherwise, install ribbon cable and proceed to next step.
2. Measure the +12VDC supply voltage to the I/O Board on I/O Board between J1-26 (+12VDC) and J1-25 (Gnd). If >11.0VDC, proceed to next step. If <11.0VDC, disconnect ribbon cable at I/O Board J1 and repeat measurement at J1. If <11.0VDC, replace the Microboard. Re-install the ribbon cable.
3. Using the Digital Outputs Procedure above, select the output that failed the digital Output test above.

4. Press **ENABLE OUTPUT** key. The LED adjacent to the selected output will illuminate. The appropriate Microboard output pin at J19 for the selected output should be at a Logic Low level (<1.0VDC). If it is >1.0VDC, replace the Microboard. With the output at a Logic Low, the following should occur:
 - a. If a Relay is selected as the output, the contacts of the relay should be closed. If they are not closed, replace the I/O Board.
 - b. If a Triac is selected as the output, the Triac should be turned on. If the Triac has not turned on, replace the I/O Board. See note 1 below for Triac testing.
5. Press **DISABLE OUTPUT** key. The LED adjacent to the selected output will extinguish.
 - a. If a Relay is selected as the output, the appropriate Microboard output pin at J19 for the selected output should be at a Logic High (>10.0VDC) level. With the output at a Logic High level, the relay contacts should be open. If they are not open, replace the I/O Board. If it is <10.0VDC, remove the ribbon cable from J1 of the I/O Board. On the I/O Board, measure the resistance from J1-26 to the appropriate pin of J1 on the I/O Board for the selected relay. If the resistance is >100 Ohms, replace the I/O Board. If the resistance is <100 Ohms, replace the Microboard.
 - b. If a Triac is selected as the output, the appropriate Microboard output pin at J19 for the selected output should be at a Logic High (>10.0VDC) level. If it is <10.0VDC, replace the Microboard. With the output at a Logic High level, the Triac should be turned off. If the Triac has not turned off, replace the I/O Board. See note 1 below for Triac testing.

Notes:

1. The load (actuator) must be connected across the Triac to determine the on/off state of the Triac. The on/off state of the Triac can be determined by measuring across the device (for example, TB1-3 to TB1-59 or TB1-58 to TB1-59) with an AC Voltmeter. If the Triac is turned on, the voltage will be <10VAC. If the Triac is turned off, the voltage will be >100VAC (Slide Valve Actuator) or >20VAC (PRV, Hot Gas or Refrigerant Level Control Actuator).

ANALOG INPUTS TEST

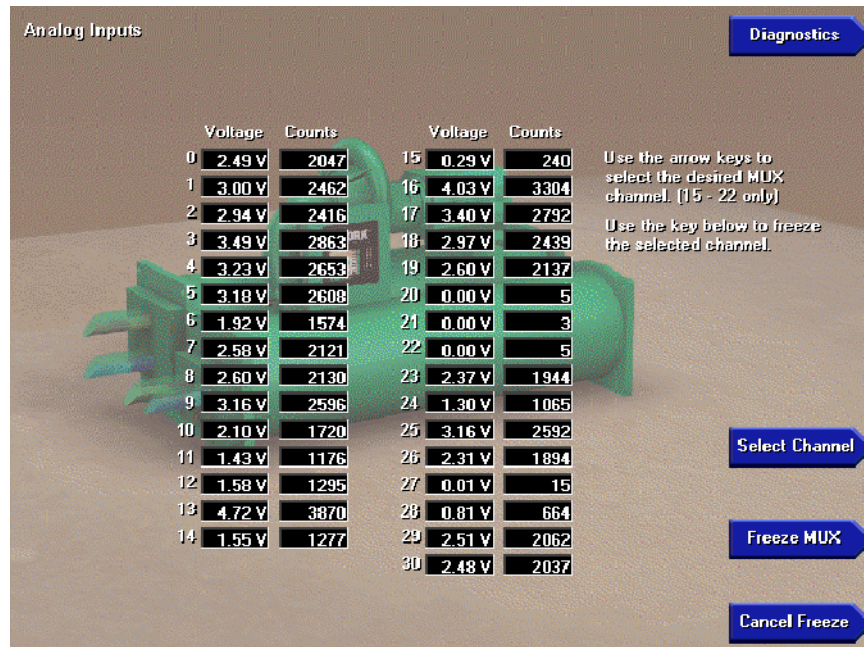

FIG. 81 – ANALOG INPUTS TEST SCREEN

00341VIP

This diagnostic is used to analyze the Analog Inputs to the Microboard. The voltage level of each Analog input, as interpreted by the Microboard, is displayed. The “Counts” listed for each parameter is the Analog-to-Digital (A/D) converter value and is for manufacturing and engineering use only.

If the chiller is shutting down on an Analog Safety or is prevented from starting because of an Analog input, there is probably an Analog Input problem. This Screen can be used in the investigation of this problem.

Important! This test does not apply to the Leaving Chilled Liquid Temperature analog input, Proximity Probe DC Voltage reference or a 0-10VDC Remote Setpoint input at channels 27 and 28.

The following is a list of the Analog inputs displayed. Refer to the appropriate Section of this book for an explanation of each: Pressure Transducers - Section 17, Thermistors - Section 18, Proximity Probe - Section 13, Refrigerant Level Control - Section 14, Solid State Starter (Mod “A” only) - Section 11 and Current Module (CM-2) - Section 10.

Channel

- 0 - +2.5VDC Analog supply voltage reference. Microboard TP6.
- 1 - Not Used

- 2 - Return Chilled Liquid Temperature
- 3 - Leaving Condenser Liquid Temperature
- 4 - Return Condenser Liquid Temperature
- 5 - Drop Leg Refrigerant Temperature
- 6 - Discharge Temperature
- 7 - Oil Temperature
- 8 - Evaporator Refrigerant Temperature
- 9 - Condenser Pressure
- 10 - Evaporator Pressure
- 11 - Sump Oil Pressure
- 12 - Pump Oil Pressure
- 13 - Proximity Probe DC Voltage Reference (Not applicable to “P” compressors and style “F” and later chillers with “G, Q” and “H5-8” compressors)
- 14 - Proximity Probe Position (Not applicable to “P” compressors and style “F” and later chillers with “G, Q” and “H5-8” compressors)
- 15 - Solid State Starter/CM-2 MUX output Channel 0
- 16 - Solid State Starter/CM-2 MUX output Channel 1
- 17 - Solid State Starter/CM-2 MUX output Channel 2
- 18 - Solid State Starter/CM-2 MUX output Channel 3
- 19 - Solid State Starter/CM-2 MUX output Channel 4
- 20 - Solid State Starter/CM-2 MUX output Channel 5
- 21 - Solid State Starter/CM-2 MUX output Channel 6

- 22 - Solid State Starter/CM-2 MUX output Channel 7
- 23 - Refrigerant Level Position
- 24 - Stall Transducer Output (Chillers equipped w/ Variable Geometry Diffuser)(Software version C.MLM.01.14.xxx (and later) or C.OPT.01.14.306 (and later))
- 25 - Stall Detector Board output (chillers equipped with Variable Geometry Diffuser only) (Software version C.MLM.01.10.xxx (and later) or C.OPT.01.10.302 (and later))
- 26 - Pre-rotation Vanes Potentiometer output (chillers equipped with Variable Geometry Diffuser but not equipped with compressor motor Variable Speed Drive or Hot Gas Bypass) (Software version C.MLM.01.10.xxx (and later) or C.OPT.01.10.302 (and later))
- 27 - Remote Leaving Chilled Liquid Temperature Setpoint (0-20mA or 4-20mA)
- 28 - Remote Current Limit Setpoint (0-20mA or 4-20mA)
- 29 - Condenser Flow Sensor (style F and later chillers) (Flash Memory Card version C.MLM.01.07.xxx and later).
- 30 - Evaporator Flow Sensor (style F and later chillers) (Flash Memory Card version C.MLM.01.07.xxx and later)

Procedure:

1. From the chart above, select the analog input that is malfunctioning. All inputs except channel 0, 15 through 22, 27 and 28 are sensors that connect directly to the Microboard via shielded cable. Channel 0 is a reference voltage for the Analog circuits on the Microboard. Channels 15 through 22 are multiplexed outputs from the Solid State Starter (Solid State Starter applications) or CM-2 Current Module (Electro-Mechanical Starter applications). Channels 27 and 28 are Remote Setpoint inputs used in Analog Remote mode.
2. Refer to Wiring Diagrams listed in front of this Section to identify the device that performs this function and the jack and pin connection to the Microboard.
3. • **Channel 0:**
Using a Voltmeter, measure the voltage between Microboard TP6 (+2.5VDC) and TP1 (Gnd). Compare this measured value to the displayed value. If the value is not within $\pm 10\%$, replace the Microboard.

• All channels except 0, 1, 15-22:

Using a Voltmeter, measure the analog input to the Microboard. Make the measurement between the device output and Ground connection to the device. For example, measure the output of the Evaporator Transducer at Microboard J8-18 (signal) to J8-9 (Gnd).

• Channels 15-22:

Select the desired channel by pressing the **SELECT CHANNEL** key and using the **▲** and **▼** keys to place the arrow head next to the desired channel. Then, freeze the address of that channel to the Solid State Starter or CM-2 MUX. Then measure MUX output at Microboard J10-6 (signal) to J10-5 (Gnd). When completed, press **CANCEL FREEZE** key.

• Channels 27, 28:

IMPORTANT! This procedure only applies to 4-20mA inputs. It does not apply to 0-10VDC inputs. Using a Voltmeter, measure the Remote Current Limit setpoint input at J22-2 (signal) or Remote Leaving Chilled Liquid Temperature setpoint input at J22-4 (signal) to J22-5 (Gnd).

4. Compare the measured value in the previous step with the value displayed on the Analog Inputs Screen for that value.
5. If the measured value is not within $\pm 15\%$ of the displayed value, replace the Microboard. Otherwise, proceed to the troubleshooting procedure below to find the cause of the problem.
6. When all desired tests have been performed, press **DIAGNOSTICS** key to return the **MAIN DIAGNOSTICS** Screen.

Troubleshooting :

• All Channels except 0, 1, 15-22, 27, 28:

1. Disconnect both ends of the cable of the Analog input that is malfunctioning. Using an Ohmmeter, perform a continuity test on all conductors in the cable. An open circuit would indicate the cable is defective.
2. Using a Voltmeter, measure the +12VDC supply voltage input at the Microboard J1-3 (+12VDC) to J1-2 (Gnd). If voltage is $< 11.5\text{VDC}$, check wiring to Power Supply. If wiring is OK, the Power supply is most likely defective.
3. Using a Voltmeter, measure the supply voltage (+5VDC, +1 2VDC or +24VDC) to the sensor. If voltage is not within $\pm 10\%$ of specified voltage,

disconnect J7, J8 and J9 from the Microboard. This disconnects all analog devices from the Microboard. If the voltage increases to the correct level, a Thermistor or Transducer is shorted. Locate the shorted device and replace. If, after disconnecting the connectors the supply voltage is still not within 10% of the specified value, the voltage supply source (Microboard or Power Supply) is most likely defective.

4. Verify sensor accuracy using appropriate test device. Replace sensor if necessary.

• **Channels 15 - 22:**

1. Disconnect both ends of ribbon cable connected to Microboard J10. Using an Ohmmeter, perform a continuity test on all conductors in the cable. An open circuit would indicate the cable is defective.
2. Using a Voltmeter, measure the +12VDC supply voltage input at the Microboard J1-3 (+12VDC) to J1-2 (Gnd). If voltage is <11.5VDC, check wiring to Power Supply. If wiring is OK, the Power Supply is most likely defective.
3. Using a Voltmeter, measure the +5VDC supply voltage to the Solid State Starter Logic Board or CM-2 Board. Make measurement at Microboard J10-4(+5VDC) to J10-5 (Gnd). If voltage is <4.5VDC, replace the Microboard.
4. Using a Voltmeter, verify the correct address is being sent from the Microboard to the Solid State Starter Logic Board or CM-2 Board. Freeze address as described above. If the address is correct, the Solid State Starter Logic Board or CM-2 Board or input devices to these boards is most likely the cause of the problem. If address is not correct, the Microboard is most likely the cause of the problem.
5. Press **CANCEL FREEZE** key.

• **Channels 27, 28:**

1. Refer to Table 1 “Microboard Program Jumpers” and verify Program Jumpers JP23 and JP24 are configured correctly for the type of input (0-10VDC or 4-20mA).
2. Disconnect both ends of the cable of the remote input that is malfunctioning. Using an Ohmmeter, perform a continuity check on all conductors in the cable. An open circuit would indicate the cable is defective.
3. If steps are OK, problem most likely is in the remote device that supplies the remote signal.

**SECTION 29
SYSTEM COMMISSIONING CHECKLIST**

Use the following checklist during commissioning to assure all Setpoints have been programmed to the desired value and all calibrations have been performed. The programming of some of the Setpoints require a **SERVICE** access level. To assure access to all Setpoints, login at **SERVICE** access level before beginning. The Setpoints are grouped under the Display Screen in which they appear. The indented screens are subscreens of the numbered screens and are accessed from the numbered screens. An explanation of each setpoint or Calibration Procedure below is contained in the reference document listed in parenthesis adjacent to each item. If any of the Setpoints have to be changed, use the standard programming procedures in Operation Manual Form 160.54-O1. Thresholds, values and calibrations of items marked with an asterisk "*" have been determined and entered/set at the YORK Factory at the time of manufacture.

1. PROGRAM JUMPERS/SWITCHES:
(160.54-M1)

____ Verify Microboard Program Jumpers and Program Switches are configured appropriately. If equipped with Microboard 031-01730-000, refer to Section 3 Tables 1 and 2. If equipped with Microboard 031-02430-000/-001, refer to Section 3A Table 3 and 4.

2. EVAPORATOR Screen: (160.54-O1)

Enter the following Setpoints:

- ____ Leaving Chilled Liquid Temp (except ISN Remote mode)
- ____ Remote Leaving Chilled Liquid Temp. Setpoint Range (except ISN Remote mode)
- ____ Low Chilled Liquid Temp cycling shutdown temperature
- ____ Low Chilled Liquid Temp cycling shutdown Restart temperature
- ____ Leaving Chilled Liquid Temp control Sensitivity (160.54-M1)
- ____ Brine Low Evaporator Pressure Cutout threshold* (160.54-M1)
- ____ Smart Freeze Protection On/Off (160.54-M1)
- ____ Refrigerant Temp sensor Enable/Disable (160.54-M1)

3. CONDENSER Screen: (160.54-M1)

- ____ Enter the High Pressure Limit/Warning threshold Setpoint
- ____ Drop Leg refrigerant Temp Sensor Enable/Disable

**REFRIGERANT LEVEL CONTROL/
TUNING Screen:** (160.54-M1)

Verify the following Setpoints:

- ____ Level Setpoint*
- ____ Control Period*
- ____ Proportional Limit Open*(Software version C.MLM.01.11.xxx (and earlier) or C.OPT.01.11.xxx (and earlier))
- ____ Proportional Limit Close*(Software version C.MLM.01.11.xxx (and earlier) or C.OPT.01.11.xxx (and later))
- ____ Rate Limit Open*(Software version C.MLM.01.11.xxx (and earlier) or C.OPT.01.11.xxx (and earlier))
- ____ Rate Limit Close*(Software version C.MLM.01.11.xxx (and earlier) or C.OPT.01.11.xxx (and earlier))
- ____ Manual or Auto control (as desired)
- ____ Verify Refrigerant Level Sensor calibration
- ____ Valve Preset Time (Software version C.MLM.01.07.xxx (and later) or C.OPT.01.14.xxx (and later))
- ____ Ramp-up Time (Software version C.MLM.01.07.xxx (and later) or C.OPT.01.14.xxx (and later))
- ____ Rate Limit (Software version C.MLM.01.14.xxx (and later) or C.OPT.01.14.306 (and later))

4. COMPRESSOR Screen: (160.54-M1)

____ Select Pre-rotation Vanes Manual or Auto control.

PROXIMITY PROBE CALIBRATION Screen
(except "P" Compressors):

____ Verify that a Proximity Probe Reference Position* had been entered.

PRE-ROTATION VANES CALIBRATE Screen:

____ Perform Pre-rotation Vanes calibration (compressor motor VSD and Hot Gas Bypass applications only)

VSD TUNING Screen:

____ Select Auto or Manual compressor motor frequency control (compressor motor VSD applications only)

5. **HOT GAS BYPASS Screen:** (160.54-M1)

If chiller is equipped with optional Hot Gas Bypass, enable operation on the **OPERATIONS** screen and enter the following setpoints:

- ___ Maximum Open (Flash Memory Card version C.MLM.01.05.xxx and later)
- ___ Surge Sensitivity (moved to Surge Protection Screen in Flash Memory Card version C.MLM.01.05.xxx and later)
- ___ Hold Period
- ___ Close Percentage
- ___ Minimum Load
- ___ Manual or Auto Control, as desired

6. **SURGE PROTECTION Screen:** (160.54-M1)
(Flash Memory Card version C.MLM.01.05.xxx and later)

- ___ Enable/Disable Excess Surge Shutdown feature.
- ___ Enable/Disable Extended Run feature
- ___ Count Window
- ___ Count Limit
- ___ Surge Sensitivity

7. **VARIABLE GEOMETRY DIFFUSER Screen:** (160.54-M1)

If compressor is equipped with the variable Geometry Diffuser, enable operation on the **OPERATIONS** Screen and enter the following setpoints:

- ___ Surge Reaction Time
- ___ PRV Offset
- ___ Probe Wait Time
- ___ Open Pulse
- ___ High Limit
- ___ Low Limit
- ___ Extreme Stall Duration (Software version C.MLM.01.14.xxx (and later) or C.OPT.01.14.306 (and later))
- ___ PRV VGD inhibit (Software version C.MLM.01.14.xxx (and later) or C.OPT.01.14.306 (and later))
- ___ Manual or Auto control, as desired

8. **OIL SUMP Screen:** (160.54-M1)

- ___ Standby Lubrication Enable/Disable If chiller is equipped with the Oil Pump Variable speed Drive, verify the following Setpoints have been entered:
- ___ Oil Pressure Setpoint*
- ___ Control Period*
- ___ Manual or Auto control (as desired)
- ___ Oil return Min
(software version C.OPT.01.21.307 and later)

9. **MOTOR Screen:**

- ___ Enter the desired Current Limit Setpoint (160.54-O1)
- ___ Enter the desired Pulldown Demand Limit and Time Setpoint (160.54-O1)

Solid State Starter Applications: (160.54-M1)

Mod "B" Solid State Starter:

Verify the following Setpoints have been programmed:

- ___ Full Load Amps*
- ___ Start Current*
- ___ Supply Voltage Range*
- ___ Enable Open SCR Detection
- ___ Enable Shorted SCR Detection (Flash Memory Card version C.MLM.01.04.xxx and later)
- ___ KWH Reset

Medium Voltage Solid State Starter

Verify the following setpoints have been programmed:

- ___ Full Load Amps*
- ___ Start Current*

Mod "A" Solid State Starter:

Verify the following Setpoints have been programmed:

- ___ Full Load Amps*
- ___ Supply Voltage Range*
- ___ Current Unbalance Check - Enable or Disable*

Logic Board:

- ___ Verify location of 300V/600V Jumper*
- ___ Verify Start Current calibration*
- ___ Verify 105% FLA calibration*

Electro-Mechanical Starter applications:
(160.54-M1)

Current Module:

- Verify Switch S1 (Ydelta/57% or all others) setting*
- Verify Pot R16 (LRA/FLA ratio) setting*
- Verify slide bar resistor “RES” setting*
- Verify 105% FLA calibration*
- Verify 100% FLA display*

Variable Speed Drive Applications: (160.54-M1, 160.00-M4 (VSD), 160.00-M6 (MVVSD))

VSD DETAILS Screen: (VSD)

- Set chiller Full Load Amps (FLA) value by adjusting potentiometer on VSD Logic Board (R34 on logic board 031-02506; R28 on all others).

MOTOR Screen: (MV VSD)

- Full Load Amps

ADAPTIVE CAPACITY CONTROL(ACC)

DETAILS Screen:

- Surge Map Clear
- Surge Map Print
- Auto Map Print
- Surge Margin Adjust
- Auto Map Print (Modbus Protocol Configuration; software version C.OPT.01.18.307 and later)
- Surge Sensitivity (software version C.OPT..01.21.307 and later)
- Manual Surge Point
- Mapping Enable (Modbus Protocol configuration; software version C.OPT.01.21.307 and later)
- VSD Start Frequency (Modbus Protocol configuration; software version C.OPT.01.21.307 and later)

Motor Lubrication Screen:

- Enable/Disable Motor Auto Lubrication (software version C.OPT.01.16.xxx (or later))
- Enable/Disable the Motor Lubrication Warning Safety Shutdown (if Motor Lube is disabled) (software version C.OPT.01.16.xxx (or later))

10. **SETPOINTS Screen:** (160.54-O1)

With the exception of the “Remote Analog Input Range”, the setpoints listed on the **SETPOINTS** Screen have already been programmed above on Previous Screens. The values shown reflect the previously programmed values. However, the setpoints listed here can be changed on this screen if desired. This screen is used primarily as a central location from which most setpoints can be programmed. If it is not desired to change any of the listed setpoints, proceed to the **SETUP** Screen below.

- Remote Analog Input Range

SETUP Screen:

- Enable Clock
- Enter CLOCK Time and Date
- Select 12 or 24 hour display mode

Microboard 031-01730-000:

- The state of Program Jumpers/Switches that affect chiller operation are displayed. These were configured in step 1 above. Confirm they are correct. (160.54-M1 Section 3)

Microboard 031-02430-000/-001:

- The state of Program Switches SW1-1 (Refrigerant Selection) and SW1-2 (Liquid Type) is displayed. These were configured in step 1 above. Confirm they are correct. (160.54-M1)

Enter the following Setpoints: (160.54-M1)

- Chilled Liquid Pump Operation
- Motor Drive Type
- Anti-Recycle
- Power Failure Restart
- Coastdown
- Pre-run
- Oil Pump Package
- Motor Communications Protocol (software version C.OPT.01.16.xxx (or later) for VSD applications; software version C.OPT.01.18.307 (or later) for LCSSS applications) – When VSD-50Hz, VSD-60Hz or SSS-Mod B is selected as Motor Drive type Setpoint.
- MotorNodeID (software version C.OPT01.16.xxx or later) for VSD applications; software version C.OPT.01.18.307 (or later) for LCSSS applications – When Modbus is selected as Motor Communications Protocol Setpoint

- ___ Coastdown Time (software version C.OPT.01.16.307 and Later - only appears if Coastdown Setpoint above is set to STANDARD)
- ___ Condenser Temperature Range (software version C.OPT .01.19.307 and later)
- ___ PRV Position (software version C.OPT.01.21.307 and later)
- ___ Heat Recovery (software version C.OPT.01.21.307 and later)
- ___ Head Pressure Control (software version C.OPT.01.21.307 and later)

QUICK START

(Software version C.OPT.01.21.307 and later)

The Quick Start feature is useful in data center and process control applications where it is desirable to re-establish cooling as fast as possible after a shutdown or power failure. This feature, when enabled, allows quicker starts and restarts than normal by reducing the cycle time and once running, loading the chiller as fast as possible. By default, this feature is disabled. It must be enabled to use it. A complete explanation of this feature and the following setpoints is contained in Section 26 of this manual.

- Quick Start Enable
- Quick Pulldown Setpoint Offset
- Pulldown Override Time
- VSD Start Frequency
- Mapping Enable
- Quick ramp Current Threshold

This feature can only be enabled if the Motor Drive Type setpoint is set to MV VSD or VSD (and the Motor Communications Protocol Setpoint is set to MODBUS). It requires an ADMIN password to change. When logged in at ADMIN level, a QUICK START key appears on the SETPOINTS Screen. Pressing this key will navigate to the QUICK START Screen where the QUICK START MODE setpoint is used to enable/disable this feature as follows:

1. At the keypad, log in at ADMIN access level using an ADMIN password.
2. Select QUICK START screen from the SETPOINTS screen
3. Press CHANGE SETPOINTS key

4. A green box will appear around the Quick Start Mode setpoint.
5. Press the Checkmark key. A dialog box will appear allowing enable/disable of the feature
6. Use the left/right arrows to select Enable.
7. Press the Checkmark key.

Once enabled, the Quick Start setpoints can be changed using the following procedure.

1. At the keypad, login at SERVICE access level using access code 1380.
2. Select QUICK START from the SETPOINTS Screen.
3. Press CHANGE SETPOINTS key
4. A green box will appear around the first changeable setpoint. Use the UP/DN arrow keys to place the box around the setpoint to be changed.
5. Press the Checkmark key.
6. Use the left/right arrow keys to select the desired setting.
7. Press the Checkmark key.

SCHEDULE Screen:

- ___ Enable or Disable Daily start/stop schedule as required.
- ___ Enter chiller **START/STOP** schedule if required.

USER Screen:

- ___ Select desired Display language
- ___ Select desired Display units; **ENGLISH** or **METRIC**
- ___ If desired, establish custom **USER ID's** and **PASSWORDS** (160.54-M1)

COMMS Screen:

If Modem and or Printer is connected to the Microboard Serial data ports, enter the following parameters as required for each device connected:

- ___ Baud rate
- ___ Number of data bits
- ___ Number of stop bits
- ___ Parity

Enter appropriate number for Modem, Printer or ISN Remote application:

- ___ Chiller ID (identification)

PRINTER Screen:

If Printer is connected to Microboard serial ports, enter the following:

- ___ Automatic print logging Enable/disable
- ___ Automatic printer logging start time
- ___ Automatic print logging interval
- ___ Printer type
- ___ Report type; STATUS, SETPOINTS, SCHEDULE or SALES ORDER

SALES ORDER Screen:

- ___ Enter system commissioning date

OPERATIONS Screen: (160.54-M1)

- ___ Select desired Control Source (operating mode); LOCAL, ISN Remote, DIGITAL Remote or ANALOG Remote
- ___ Refrigerant Level Control operation Enable/Disable
- ___ Hot Gas Bypass Control (optional) Enable/Disable
- ___ Variable Geometry Diffuser (Enable/Disable) (Chillers equipped with Variable Geometry Diffuser. Software version C.MLM.01.10.xxx (and later) or C.OPT.01.10.302 (and Later))
- ___ Edit Regional phone number if necessary (Flash Memory Card version C.MLM.01.05.xxx and later)
- ___ Enter Local phone number (Flash Memory Card version C.MLM.01.05.xxx and later)
- ___ Enter Chiller Style/Compressor (Flash Memory Card version C.MLM.01.07.xxx and later)
- ___ Enter Flow Sensor type (Flash Memory Card version C.MLM.01.08.xxx and later).

THIS PAGE INTENTIONALLY LEFT BLANK

SECTION 30 SOFTWARE ENHANCEMENTS

SI0006 - SOFTWARE ENHANCEMENTS EFFECTIVE MAY 2001

General

Beginning May 2001, an enhanced Flash Memory Card will be supplied with new production Nema 1-4 and CE chillers. New features are outlined below and are also included in YORK Operation Manual 160.54-O1 and Service Manual 160.54-M1.

Flash Memory Card versions and part numbers are applied as follows:

- Nema 1-4 Chillers C.MLM.01.05A.102 (031-01797-001)
- CE Chillers C.MLM.01.05A.203 (031-01797-002)

The enhanced flash cards are also available from the Baltimore Parts Distribution Center for retrofit to existing chillers.

Surge Protection

The Surge protection feature detects surge events and provides a running count of the events that occur over the lifetime of the chiller. An excess surge threshold can be programmed to detect excessive surging. If excess surging is detected, it can be configured to shutdown the chiller or initiate a special surge correction/avoidance mode or simply display a warning message. A Surge Protection display Screen displays all parameters relevant to this feature.

Trend Screen – Triggered Chart

A “TRIGGERED” chart can now be created. This is in addition to the ONE SCREEN and CONTINUOUS chart types that can be created in previous Flash Memory Card versions. With the TRIGGERED chart type, data collection can be set to START or STOP based upon the status of up to two Operator selected conditions (TRIGGERS) and a selected TRIGGER DELAY. If START is selected, data collection will not begin until all triggers have been satisfied and any selected TRIGGER DELAY has elapsed. Data collection will stop at the completion of one screen of data. If STOP is selected, data collection will begin when manually initiated, and will stop when all triggers have been satisfied and any selected TRIGGER DELAY has elapsed.

This feature is a valuable troubleshooting tool for Service technicians. It allows an event that occurs during unattended hours to be captured for viewing at a later time. The trigger event results in a screen of frozen trend data that will remain on the screen until manually cleared.

Display of Service Phone Numbers

Two service phone numbers (Regional and Local), with labels, can be displayed on the **OPERATIONS** Screen. The Default value for the Regional number is the North American Toll Free number. However, the label and number can be changed to any desired value. The Local label and number can also be entered.

Hot Gas Bypass Enhancement

In previous Flash Memory Card versions, when the Leaving Chilled Liquid Temperature decreased to the “Minimum Load” setpoint, the Hot Gas Valve was opened to the 100% position. In this version, the valve will be opened to the position programmed as the “Maximum Open” setpoint (25% to 100%). This allows for better control of the minimum load conditions. After the Minimum Load operation is activated, the valve will be closed proportionately as the Leaving Chilled Liquid Temperature increases to the Leaving Chilled Liquid Temperature Setpoint.

“Evaporator-Transducer or Temperature Sensor” Safety Shutdown

SI0006 - SOFTWARE ENHANCEMENTS EFFECTIVE MAY 2001 (CONT'D)

In Previous Flash Memory Card versions, the conditions for this safety shutdown were checked after the first 10 minutes of chiller run. Under certain operating conditions this would result in unnecessary shutdowns. In this version, in addition to the previous criteria, the shutdown conditions are not checked unless Smart Freeze is enabled and the Evaporator Refrigerant Temperature RT7 (if enabled) or Evaporator Saturation Temperature (derived from the evaporator pressure transducer) is $< 32^{\circ}$ F.

Compressor Motor Variable Speed Drive

1. The compressor motor VSD phase A, B and C output current to the motor is now displayed on the VSD Tuning Screen.
2. The new 351HP VSD is supported. In this model, the three Inverter Assemblies are mounted on a single Baseplate instead of three individual Heatsink Assemblies, as in other models. Therefore, the VSD Details Screen and the Harmonic Filter Details Screen display a single Baseplate Temperature instead of the Phase A, B and C Temperatures displayed on other models.

Oil Pump Variable Speed Drive

In previous Flash Memory Card versions, the oil pump VSD starts at 25Hz when turned on during "System Prelube". In this version, it starts at 45Hz. This provides greater reliability in achieving the required 45 PSID Target Oil Pressure at chiller start.

SI0019 - SOFTWARE ENHANCEMENTS EFFECTIVE MARCH 2002

General

Beginning March 2002, an enhanced Flash Memory Card will be supplied in new production YK Nema 1-4 and CE chillers. The new features are outlined below.

The Flash Memory Card versions and part numbers are as follows:

- Nema 1-4 chillers (except “P” compressors).....C.MLM.01.06.100 (031-01797-001)
- CE chillers (except “P” compressors).....C.MLM.01.06.200 (031-01797-002)
- Nema 1-4 chillers (“P” compressors)C.MLM.04.02.100 (031-02073-001)
- CE chillers (“P” compressors)C.MLM.04.02.200 (031-02073-002)

These versions are also available from the Baltimore Parts Distribution Center for retrofit to existing chillers.

Operator Soft Shutdown

This feature allows an Operator (logged in at Operator Access Level, or higher) to manually initiate a soft shutdown by closing the Pre-rotation Vanes prior to shutting down the chiller. This reduces compressor bearing wear by eliminating compressor backspin at shutdown.

While the chiller is running, a **SOFT SHUTDOWN** key is available on the **Home** Screen (when Access Level is Operator or higher). Pressing this key causes the Pre-rotation Vanes to be driven fully closed. While they are closing, “Vanes Closing Before Shutdown” is displayed on the System Status line. “Local Stop” is displayed on the System Details line. When the Vane Motor Switch (VMS) closes, indicating the Vanes have fully closed (or 3.5 minutes have elapsed, whichever occurs first), the Start Signal is removed from the Starter and a normal Coastdown is performed.

While the Vanes are closing during the Soft Shutdown, if a standard Local Stop is initiated with the front panel Rocker Switch, or if any faults other than the following occur, the Soft Shutdown is terminated and it will immediately enter a normal Coastdown period:

- “Leaving Chilled Liquid – Low Temperature”
- “Remote Stop”
- “Multi-unit Cycling – Contacts Open”
- “System Cycling – Contacts Open”
- “Control Panel – Schedule”

Following an Operator initiated Soft Shutdown, the front panel Rocker Switch must be placed in the Stop/Reset position and then to the Start position in order to start the chiller after a Soft Shutdown has been performed.

Record Setpoint Changes

This feature provides a record of the last 75 Setpoint changes. The date and time the Setpoint was changed, the new Setpoint value and the Access Level and User ID used to make the change are stored in the BRAM. The Security Log Screen and the Security Log Details Screen display levels of this information. Both screens are available in Service Access level or higher.

On the **Security Log** Screen, accessible from the **History** Screen, the Setpoint, Setpoint Category and new Setpoint value are listed and numbered in reverse order in which they were changed. The most recent is listed as number 1; the next most recent as number 2, etc. A **PRINT** key allows printing this entire list. Since 15 changes can be displayed at one time, multiple pages could be necessary to display all the changes. **PAGE-UP** and **PAGE-DOWN** keys are provided to view the entire list. If it is desired to view the details of a particular Setpoint change, select the Setpoint change number with the **LOG ENTRY** key and then press the **VIEW DETAILS** key. This moves to the **SECURITY LOG DETAILS** Screen.

SI0019 - SOFTWARE ENHANCEMENTS EFFECTIVE MARCH 2002 (CONT'D)

The **SECURITY LOG DETAILS** Screen, accessible from the **SECURITY LOG** Screen, displays the following Setpoint change details. The Setpoint is selected from the list on the Security Log Screen as explained in the previous paragraph. A **PRINT** key is provided to print this information.

- Setpoint Category
- Setpoint
- Date and time of change
- Access Level and User ID used to make the change
- Old Value
- New Value

The following Setpoint changes are not logged:

- Clock Mode
- Custom Screen slot numbers
- Advanced Diagnostics communication port tests
- Advanced Diagnostics secondary multiplexer freeze
- Soft shutdown initiated by operator
- System language
- Display units
- Any Print report
- Cancel any print report
- Schedule clear
- Schedule repeat exception days
- Schedule start and stop times
- Log in/log out
- User attributes for ID, Password and Level
- Trend start/stop
- Trend slot numbers, minimums and maximums
- Trend trigger data
- Trend print mode
- Trend view mode

Leaving Chilled Liquid Temperature Control Sensitivity Setpoint

In addition to the **NORMAL** and **50%** selections provided in previous software versions, a **30%** selection has been added to this version. This provides less overall Pre-rotation Vane (PRV) movement than the **50%** selection by limiting the longest allowed pulse to 3.5 seconds. This selection can be used when the **50%** selection does not reduce the PRV instability to the desired level.

Refrigerant Level Control

The following features provide improved Level Control stability.

- Level Control Period Setpoint – Now programmable over the range of 3.5 to 30.0 seconds. Previously, it was 1.0 to 5.0 seconds.
- The message “Warning – Refrigerant Level Out of Range” and the associated Lower signal that opens the valve until the level is within range has been eliminated.
- The Ramp-up feature is now only executed immediately after chiller start. Subsequent Ramp functions during chiller run have been eliminated.
- Rate Limit Open Setpoint – Now programmable over the range of 5% to 50%. Previously, it was 10% to 50%.

SI0019 - SOFTWARE ENHANCEMENTS EFFECTIVE MARCH 2002 (CONT'D)

- Rate Limit Close Setpoint – Now programmable over the range of 5% to 50%. Previously, it was 10% to 50%.
- The duration of the open or close pulse applied to the Valve Actuator is now independent of the selected Period Setpoint. It is now a fixed percentage of 3.5 seconds. Previously, it was a percentage of the Period Setpoint. Therefore, longer Periods would produce longer output pulses for the same error, resulting in unstable operation under certain conditions.

Compressor Motor Variable Speed Drive

- The conditions to produce the “Harmonic Filter – Logic Board or Communications” Cycling shutdown must now be present for 10 communication cycles before a shutdown is performed.
- If either the 50% or 30% Leaving Chilled Liquid Temperature **SENSITIVITY** Setpoint is selected, Pre-rotation Vane movement is further reduced when the chiller is operating at low load. When the Vane position is less than 25% and Leaving Chilled Liquid Temperature is within ± 2.5 °F of Setpoint, the maximum Vane pulse is limited to 3.5 seconds at 25% position and 0.9 seconds at 0% position. Vane positions in between have linearly scaled maximums.
- In previous Flash Memory Card versions, the **SET FREQUENCY** Setpoint feature on the **VSD TUNING** Screen did not correctly set the desired frequency in 50Hz applications. This is corrected in this version.
- Harmonic Filter Currents are now correctly displayed at maximum values.

History

Chiller Run Time is now included on History Details display and print.

Hot Gas Bypass

The Hot Gas Valve position is now animated on the **HOT GAS BYPASS** Screen.

SI0034 (203) - SOFTWARE ENHANCEMENTS EFFECTIVE AUGUST 2002

Flash Memory Card

Beginning August 2002, an enhanced Flash Memory Card will be supplied in new production YK chillers. These Cards will accommodate the YK Style "F" chiller, scheduled for future release. The Cards are also available from the Baltimore Parts Distribution Center as replacement parts. They supersede all previous versions of the same part number. The enhancements that affect the OptiView Control Center are listed below.

The new versions are:

- Nema 1-4 chillers (all compressors).....C.MLM.01.07.104 (031-01797-001)
- CE chillers (all compressors).....C.MLM.01.07.205 (031-01797-002)

In addition to being used on all YK Style "F" chiller/compressor combinations, they are backward compatible to all previous style YK chiller/compressor combinations. The new card supersedes and will be supplied in place of 031-02073-001 and 031-02073-002 Flash Memory Cards that were previously used for "P" compressor applications. Part number 031-01797-001 will be supplied in place of 031-02073-001 and 031-01797-002 will be supplied in place of 031-02073-002

The various YK chiller modification level (style)/compressor combinations are equipped differently and have different control requirements. Variables include the following:

- High Speed Thrust bearing proximity sensing – Proximity Probe or Limit Switch
- Flow Sensor – Paddle type (115Vac digital input) or factory mounted thermal type sensor (+5Vdc analog input)
- Oil Heater Outputs – Either TB1-34 or TB1-64 on I/O Board
- Refrigerant Level Control Default Period – Either 3.5 seconds or 10.0 seconds
- "Oil – Variable Speed Pump-Pressure Setpoint Not Achieved" safety shutdown threshold – Either 25 PSID or 35 PSID

Flash Memory Card version C.MLM.01.07.xxx and later are applicable and backward compatible to all YK chiller/compressor combinations. They contain all control variables for all combinations. For correct control, the chiller mod level/compressor size combination must be entered (using **Service Access** level) using the **CHILLER MOD** Setpoint key on the **OPERATIONS** Screen. The selections are as follows: (Default is "Mod F – GH Compr")

- a. "Mod F – GH Compr"
- b. "Mod F – J Compr"
- c. "Mod F – P, Q Compr"
- d. "Mod CDE – GHJ Compr"
- e. "Mod E – P Compr"

Once the appropriate chiller/compressor combination is entered, the program automatically bundles the functionality and control per the following table:

SI0034 (203) - SOFTWARE ENHANCEMENTS EFFECTIVE AUGUST 2002 (CONT'D)

Chiller Mod – Compressor	Proximity Sense	Oil Heater Output*	Level Control Period Default	Flow Switch	“Oil-Variable Speed Pump Pressure Setpoint Not Achieved” Threshold*
“Mod C, D, E – G, H, J Compr”	Probe	TB1-34	3.5 sec	Paddle Type	35 PSID
“Mod E – P Compr”	Limit Switch	TB1-64	10.0 sec	Paddle Type	25 PSID
“Mod F – G, H Compr”	Limit Switch	TB1-64	3.5 sec	Factory Mounted Thermal Type	35 PSID
“Mod F – J Compr”	Probe	TB1-64	3.5 sec	Factory Mounted Thermal Type	35 PSID
“Mod F – P, Q Compr”	Limit Switch	TB1-64	10.0 sec	Factory mounted Thermal Type	25 PSID

* Not applicable to Mod C and earlier chillers.

Factory Mounted Flow Sensors

Style "F" (and later) chillers are supplied with factory-mounted Flow Sensors on the evaporator and condenser. These are electronic thermal-type sensors. The operating principle of the sensor is thermal conductivity. It uses the cooling effect of a flowing liquid to sense flow. The temperature of the heated sensor tip is sensed by a thermistor located in the tip.

A second thermistor, located higher in the tip in a non-heated area, is only affected by changes in liquid temperature. The temperatures sensed by the thermistors are compared. Flowing liquid carries heat away from the heated sensor tip, lowering its temperature. The lower temperature differential between the two thermistors indicates the liquid is flowing. A higher differential indicates no flow. Each device operates from a 24Vac power source and has a solid state relay output. On each sensor, one side of the solid state relay output (pin 2) is connected to the microboard +5Vdc and the other side (pin 4) is connected to a microboard analog input.

When flow is sensed, the solid state relay output is turned on causing it to conduct current through the 7.5K ohm microboard load resistor to the +5vdc. This applies >+4Vdc to the microboard input (evaporator J7-14; condenser J7-16). When no flow is sensed, the solid state relay output is turned off, resulting in no conduction through the load resistor. This applies <1Vdc to the microboard input. To determine the state of the solid state relay, first confirm that +5vdc is present at pin 2 of the flow sensor. Then connect a voltmeter from Microboard J7-14 (evaporator) or J7-16 (condenser) to microboard TP1 (ground).

The power source is connected to the sensor as follows:

<u>From</u>	<u>To</u>
Sensor pin 1	TB1-162 (24Vac)
pin 3	TB6-5 (Gnd)

The sensor outputs are connected to the Microboard as follows:

Evaporator:

<u>From</u>	<u>To</u>
Sensor pin 2	Microboard J7-1 (+5Vdc)
pin 4	J7-14 (input to Microboard)

Condenser:

Sensor pin 2	Microboard J7-15 (+5Vdc)
pin 4	J7-16 (input to Microboard)

Microboard Program Jumpers JP21 and JP22 must be placed in the positions 2 & 3.

SI0034 (203) - SOFTWARE ENHANCEMENTS EFFECTIVE AUGUST 2002 (CONT'D)

Proximity Probe/Limit Switch

Previously, YK chillers equipped with “P” compressors used the High Speed Thrust Bearing Limit Switch and all other compressors used the Proximity Probe. With Style “F” chillers, only the “J” compressor will use the Proximity Probe. Compressors “G”, “H” and “P” will use the Limit Switch.

In previous Flash memory card versions, the Thrust Bearing Limit Switch indication shows a lit LED for a normal condition and unlit for a faulted condition. In this version, an unlit LED indicates a normal condition and a lit LED indicates a faulted condition.

Refrigerant Level Control

In previous Flash Memory Card versions, this control operates as follows:

When the chiller enters “**System Run**”, if the Refrigerant Level Position is less than the **CONTROL SETPOINT**, a linearly increasing ramp limit, called the **REFRIGERANT LEVEL TARGET**, is applied to the **CONTROL SETPOINT**. This ramp limit allows the level to go from the present programmed level to the programmed **CONTROL SETPOINT** over a period of 15 minutes. During these 15 minutes, the **REFRIGERANT LEVEL TARGET** is used to control the condenser refrigerant level. The **CONTROL SETPOINT** is then used to control the refrigerant level for the remainder of chiller run.

In this version, the control will operate as follows:

- While the chiller is stopped, or if the Level Control is disabled, the Refrigerant level “**Lower**” output is energized.
- Upon entering chiller Prelube, the Refrigerant Level “**Raise**” output is energized for the length of the programmable **VALVE PRESET TIME** setpoint (0 to 100 seconds; default 50; Service access level). After pre-positioning, the valve is held in this position until the first 3 minutes of chiller run time have elapsed. Setting the **VALVE PRESET TIME** to 0 seconds disables this pre-positioning feature. Setting the Valve Preset Time to a value greater than 50 seconds has no effect on the Prelube time.
- After 3 minutes of run time, if the Refrigerant Level is less than the **CONTROL Setpoint**, a linearly increasing ramp limit, called the **REFRIGERANT LEVEL TARGET**, is applied to the programmed Control Setpoint. This ramp limit allows the level to go from the present level to the **CONTROL SETPOINT** over a period of time programmed as the **RAMP-UP TIME** Setpoint (3 to 15 minutes; default 8; Service access level). During this ramp-up period, the **REFRIGERANT LEVEL TARGET** is used to control the refrigerant level in the condenser. The **CONTROL SETPOINT** is used to control the level during the remainder of chiller run.
- If the **VALVE PRESET TIME SETPOINT** is set to 0 seconds and the **RAMP-UP TIME** Setpoint is set to 15 minutes, Refrigerant Level Control will operate exactly the same as previous Flash Memory Card versions.

Microboards

Since the new version Flash Memory Card (as described above) is applicable to all YK chillers with any compressor, the Microboard replacement kit 331-01730-604 previously supplied for YK chillers equipped with “P” compressors is no longer required. The standard 331-01730-601 Microboard replacement kit will be supplied when the 331-01730-604 is ordered.

SI0058 - SOFTWARE ENHANCEMENTS EFFECTIVE FEBRUARY 2003

General

Beginning February 2003, an enhanced Flash memory Card will be supplied in all new production YK chillers. These cards are backward compatible to all previous YK chillers and are available from the Baltimore Parts Distribution Center as replacement parts. The enhancements are outlined below.

The versions and part numbers are applied as follows:

- NEMA 1-4 chillers C.MLM.01.08.105 (p/n 031-01797-001)
- CE chillers C.MLM.01.08.206 (p/n 031-01797-002)

Flow Sensors

Mod (Style) F chillers are provided with factory mounted thermal-type flow sensors for the evaporator and condenser. However, this Flash Memory Card version allows Style F chillers to use either the thermal-type or field installed paddle-type flow sensor. The thermal-type sensors interface to Microboard +5Vdc analog inputs at J7-14 (evaporator) and J7-16 (condenser). The paddle-type sensors interface to the I/O board 115Vac digital inputs at TB4-12 (evaporator) and TB4-11 (condenser). For the program to read the appropriate inputs for the flow sensor status, the actual sensor type used must be entered at the keypad **OPERATIONS** Screen using the Service Access Level.

If the chiller Mod (style) level setpoint on the **OPERATIONS** Screen is set to "F" (any compressor), the "**FLOW SWITCH**" key appears on the **OPERATIONS** Screen allowing the flow sensor type to be entered. The selections are "Analog" (thermal-type) or "Digital" (paddle-type). If Analog is selected, the program reads the thermal-type flow sensor inputs at Microboard analog inputs J7-14 (evaporator) and J7-16 (condenser) and ignores the Digital inputs. If Digital is selected, the program reads the paddle-type sensor inputs at the I/O Board digital inputs TB4-12 (evaporator) and TB4-11 (condenser) and ignores the Analog inputs.

Enter the applicable flow sensor type as follows:

1. Select **SETPOINTS/SETUP/OPERATIONS** Screen.
2. Press **FLOW SWITCH** key.
3. Use ◀ or ▶ keys to select flow sensor type. Each time the key is pressed, Analog or Digital is alternately displayed.
4. Press ENTER (✓) key.

Variable Speed Drive Oil Pump

When the oil pump is started during System Prelube, the pump speed command is held at 45Hz for the first 8 seconds before releasing to normal control.

Oil Pressure Threshold

The threshold for "Oil – High Differential Pressure" safety shutdown is changed from 90 PSID to 120 PSID.

Compressor Motor Variable Speed Drive (VSD)

This Flash Memory Card version supports VSD part number 371-03789-xxx (503HP; 60Hz) (419HP; 50Hz). Display messages unique to this drive are displayed appropriately on the screens as follows: Phase A, B and C Baseplate Temperatures are displayed on the VSD DETAILS Screen and Filter Baseplate Temperature is displayed on the **FILTER DETAILS** Screen.

SI0058 - SOFTWARE ENHANCEMENTS EFFECTIVE FEBRUARY 2003 (CONT'D)

In addition to standard VSD Cycling messages, the following Cycling shutdown messages apply to this VSD:

“VSD – Low Phase A Inverter Baseplate Temperature”

The chiller has shutdown because the Baseplate temperature has decreased to <37 °F.

“VSD – Low Phase B Inverter Baseplate Temperature”

Same as phase A above.

“VSD – Low Phase C Inverter Baseplate Temperature”

Same as phase A above.

In addition to standard VSD Safety shutdown messages, the following Safety shutdown messages apply to this VSD:

“VSD – High Phase A Inverter Baseplate Temperature”

The chiller has shutdown because the Baseplate temperature has increased to >158 °F.

“VSD – High Phase B Inverter Baseplate Temperature”

Same as phase A above.

“VSD – High Phase C Inverter Baseplate Temperature”

Same as phase A above.

“Harmonic Filter – High Baseplate Temperature”

The chiller has shutdown because the Baseplate temperature has increased to >194 °F.

Microgateway

In previous Flash Card versions, “Start Inhibit” and “Modified Run” codes were transmitted into “Cycling” and “Safety” shutdown slots in the Microgateway. This alarmed external devices that a Cycling or Safety shutdown has occurred, when in reality, a Start Inhibit such as Anti-recycle or a Modified Run event such as Current Limit is in effect. This was incorrect operation. In this version, the codes are transmitted into the proper slots in the Microgateway.

Security Log Screen

In previous Flash Card versions, some setpoint changes were not logged in metric mode. All setpoint changes are now logged.

SI0062 - SOFTWARE ENHANCEMENTS EFFECTIVE MARCH 2003**General**

Beginning March 2003, an enhanced Flash Memory Card will be supplied in all new production YK chillers. These cards are backward compatible to all previous YK chillers and are available from the Baltimore Parts Distribution Center as replacement parts. The enhancements are outlined below.

The versions and part numbers are applied as follows:

- NEMA 1-4 chillers C.MLM.01.08.105A (p/n 031-01797-001)
- CE chillers C.MLM.01.08.206A (p/n 031-01797-002)

Chiller Style/Compressor Setpoint

In previous Flash Memory Card version, this setpoint key (located on **OPERATIONS** Screen), was labeled **“CHILLER MOD”**. For clarity, this setpoint key is now labeled **“CHILLER STYLE/COMPRESSOR”** (English only). The functionality of this setpoint has changed slightly as follows:

The previous choice of “Style F chiller/G, H compr” is now “Style F chiller/G, H5-8 compr”. The previous choice of “Style F chiller/J compr” is now “Style F chiller/J, H3 compr”.

The Chiller Style/Compressor selections are shown below.

Chiller Style/Compressor	Proximity Sense	Oil Heater Output*	Level Control Period Default	Flow Switch	“Oil-Variable Speed Pump-Pressure Setpoint Not Achieved” Threshold*
“Style C, D & E/ G, H & J Compr”	Probe	TB1-34	3.5 sec	Digital (Paddle Type)	35 PSID
“Style E/ P Compr”	Limit Switch	TB1-64	10.0 sec	Digital (Paddle Type)	25 PSID
“Style F/ G & H5-8 Compr”	Limit Switch	TB1-64	3.5 sec	Programmable (Analog or Digital)	35 PSID
“Style F/ J & H3 Compr”	Probe	TB1-64	3.5 sec	Programmable (Analog or Digital)	35 PSID
“Style F/ P, Q Compr”	Limit Switch	TB1-64	10.0 sec	Programmable (Analog or Digital)	25 PSID

* Not applicable to Style C and earlier chillers

This page intentionally left blank.

SI0080 - SOFTWARE ENHANCEMENTS EFFECTIVE JANUARY 2004**General**

Beginning January 2004, enhanced software will be supplied in all new production YK chillers. It is backward compatible to all previous YK chillers. The enhancements are outlined below.

The versions and part numbers for 031-01730-000 Microboards are as follows:

- NEMA 1-4 chillers C.MLM.01.09.106 (p/n 031-01797-001)
- CE chillers C.MLM.01.09.207 (p/n 031-01797-002)

The versions and part numbers for 031-02430-000 Microboards are as follows:

NEMA 1-4 & CE chillers C.OPT.01.09.301 (p/n 031-02474-001)

OptiSave Energy Analyzer Feature

This feature reveals the advantage of a compressor motor variable speed drive. It calculates the amount of energy that has been saved by having a variable speed drive instead of a constant speed drive. The savings is determined by calculating the energy consumption of a constant speed drive and subtracting the measured energy consumption of the variable speed drive. The resulting difference is the energy savings. This data is displayed, but does not affect chiller operation or performance.

Although this feature is present in this software, it is not operational until enabled using a special procedure.

Refer to Service Information letter SI0068 for a complete description of this feature. It provides all required installation, enable and setup information.

Surge Protection

If the chiller is equipped with a compressor motor Variable Speed Drive (VSD):

- The surge SHUTDOWN feature, EXTENDED RUN feature and surge warning messages will not be performed unless the VSD output frequency is at maximum.

If the chiller is equipped with both a VSD and the Hot Gas Bypass feature:

- The Hot Gas Valve position must be at 100% AND the VSD output frequency must be at maximum before the above surge features are performed.

For all applications, the COUNT WINDOW setpoint default is now 3 minutes (was 5 minutes). The COUNT LIMIT setpoint default is now 15 surges (was 4 surges).

SI0080 - SOFTWARE ENHANCEMENTS EFFECTIVE JANUARY 2004 (CONT'D)

Pre-rotation Vanes Calibration

There is now one procedure for all Pre-rotation Vanes (PRV) calibrations. This procedure applies to the compressor motor Variable Speed Drive (VSD), Hot Gas Bypass, Variable Geometry Diffuser and any other PRV calibration.

1. Place the COMPRESSOR switch in the Stop-reset position (O) and wait until the System Coastdown is complete.
2. At the keypad, login at Service access level.
3. Select the PRE-ROTATION VANES CALIBRATE screen from the COMPRESSOR screen.
4. Press the START CALIBRATION key to initiate the calibration. The CALIBRATION IN PROGRESS and PRV OPENING LED will illuminate and an open signal is applied to the PRV. After a 60 second delay, the program begins evaluating the feedback voltage from the PRV potentiometer. When the feedback voltage stops increasing and remains stabilized (so that there is no more than ± 0.25 vdc deviation) for 25 continuous seconds, the feedback voltage is logged as the 100% position. A close signal is then applied to the PRV and illuminates the PRV CLOSING LED. After a 10 second delay, the program begins evaluating the feedback voltage from the PRV potentiometer. When the feedback voltage stops decreasing and remains stabilized (so that there is no more than ± 0.25 vdc deviation) for 25 continuous seconds, the feedback voltage is logged as the 0% position. These endpoint voltages are stored in the BRAM as the full open and full closed positions.
5. If the difference between the endpoint voltages is greater than 0.5vdc, "PRV Calibration Successful" is displayed. Otherwise, "PRV Calibration Unsuccessful" is displayed. Also, if the endpoints are not established within 10 minutes, "PRV Calibration Unsuccessful" is displayed.

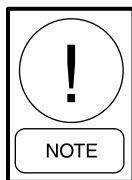

The calibration procedure can be terminated at any time during the procedure by pressing the CANCEL CALIB key. If the PRV were previously calibrated successfully, it will revert to using the previous calibration values. If they were not previously calibrated successfully, they will remain uncalibrated.

VSD Adaptive Capacity Control - Stability Limit Setpoint

This compressor motor Variable Speed Drive setpoint default is now 7000 (was 4500).

Microgateway Induced Reboots

With previous Flash Memory Card versions, Microgateway communications could cause the Microboard to randomly reboot. This has been corrected in this version.

SI0089 - SOFTWARE ENHANCEMENTS EFFECTIVE MAY 2004**General**

Beginning May 2004, enhanced software will be supplied in all new production YK chillers. It is backward compatible to all previous YK chillers. The enhancements are outlined below.

The versions and part numbers for 031-01730-000 Microboards are:

- NEMA 1-4 chillers C.MLM.01.11.108 (p/n 031-01797-001)
- CE chillers C.MLM.01.11.209 (p/n 031-01797-002)

The version and part number for 031-02430-000 Microboards are:

- NEMA 1-4 and CE Chillers C.OPT.01.11.303 (p/n 031-02474-001)

High Condenser Pressure Fault While Shutdown

High temperature condenser water flowing through the condenser while the chiller is shutdown can cause a condenser high pressure condition resulting in loss of refrigerant. Therefore, an anticipatory safety fault has been created to announce condenser high pressure conditions when the chiller is stopped as follows:

While the chiller is stopped, if the condenser pressure exceeds 160.0 PSIG (R134a), 240.0 PSIG (R22), a safety fault occurs and “Condenser – High Pressure - Stopped” is displayed.

The chiller can be started after the condenser pressure decreases to less than 160.0 PSIG (R134a), 240.0 PSIG (R22) and a special reset procedure is performed as follows:

1. Place the COMPRESSOR switch in the Stop-reset position.
2. At the keypad, login at Service access level using code 1 3 8 0.
3. Select COMPRESSOR screen.
4. Press the FAULT ACKNOWLEDGE key on the COMPRESSOR Screen. A dialog box appears displaying “Enter Password to Clear Fault”.
5. Enter 1 3 9 7 and press the ENTER key (√).

This anticipatory fault is only performed while the chiller is stopped. If a “Condenser – High Pressure” fault is detected while the chiller is in Pre-lube, System Run or Coastdown, the fault is handled in the normal way and does not require the special reset procedure.

Style B Solid State Starter Faults

The following changes apply to faults detected by the Style B Liquid Cooled Solid State Starter (LCSSS):

Open SCR (Silicon Controlled Rectifier) Fault

When the Solid State Starter initiates a shutdown, the fault data transferred to the OptiView Control Center is a function of the eeprom (U16) in the starter Logic/Trigger Board.

SI0089 - SOFTWARE ENHANCEMENTS EFFECTIVE MAY 2004 (CONT'D)

Previously, in starters equipped with eprom version C.SSS.01.00 through C.SSS.01.02, when an Open SCR fault occurred, the fault data returned from the starter did not identify the phase in which the fault occurred. Therefore, the message displayed by the OptiView Control Center was “LCSSS – OPEN SCR”. New version C.SSS.01.03 eprom now supplied in the starter Logic/Trigger Board, returns fault data that identifies the phase in which the Open SCR condition is detected.

This Flash Memory Card version interprets this fault data and displays a message that identifies the defective phase. Therefore, when this Flash Memory Card version is used with a starter Logic/Trigger Board equipped with version C.SSS.01.03 (and later) eprom, “LCSSS – Phase X Open SCR” (X replaced by A, B or C as appropriate) is displayed when the fault occurs.

Start Inhibit Faults

The following Start Inhibit Faults are no longer logged on the History Screen. They will continue to be displayed on the System Details line of the display and transferred to the MicroGateway.

“LCSSS – Phase X Heatsink Temperature – Stopped” (X replaced by A, B or C as appropriate)

Diagnostics Screen

The communications error counters now count up to 65535 (was 255).

Variable Speed Oil Pump

In previous Flash Memory Card versions, the manual frequency could be changed only when the pump was running. The manual frequency can now be changed whether the pump is running or not.

Invalid System Details Messages

In previous Flash Memory Card versions, there have certain operating conditions that could cause messages on the System Details line of the display to become “stuck”. The most prevalent one was “Motor – High Current Limit”. This has been corrected in this version.

History Data Storage

The data capture has been modified to assure that all data is that which is valid at the instant of the event.

160.54-M1 (LS05) SOFTWARE ENHANCEMENTS EFFECTIVE MARCH 2005

General

Beginning March 2005, enhanced software will be supplied in new production YK chillers. It is backward compatible to all previous YK chillers. The enhancements are outlined below.

The versions and part numbers are:

031-01730-000 Microboard:

- NEMA 1-4 chillers
C.MLM.01.14.111 (031-01797-001)
- CE chillers
C.MLM.01.14.212 (031-01797-002)

031-02430-000 Microboard:

- NEMA 1-4 and CE chillers
C.OPT.01.14.306 (031-02474-001)

Stall Sensor Validation

This feature verifies the operation of the Stall Pressure Transducer (used for the Variable Geometry Diffuser operation) by comparing its voltage output to the voltage output of the Condenser Pressure Transducer while the chiller is running. If the Stall Transducer is not reading within an acceptable range of the condenser transducer, "Warning – Condenser or VGD Sensor Failure" is displayed and the Variable Geometry Diffuser (VGD) is driven to the open position until the warning is manually cleared.

Extreme Stall Monitor

To prevent VGD damage, the VGD is disabled during extreme stall conditions and a warning message is displayed. While the chiller is running, if the Stall Detector Voltage (output of the Stall Detector Board) exceeds twice the HIGH LIMIT Setpoint, for the duration programmed as the EXTREME STALL DURATION Setpoint (10 to 20 minutes), the VGD is driven to the full open position and "Warning – Conditions Override VGD" is displayed until the Stall Detector Voltage returns to less than two times the HIGH LIMIT Setpoint the warning is manually cleared.

VGD Inhibit Setpoint

A new setpoint, PRV VGD INHIBIT, has been added to the Variable Geometry Diffuser operation. This setpoint is programmable over the range of 40% to 100%; default 95%. While the pre-rotation Vanes position is greater than this setpoint, the VGD is pulsed open according to the OPEN PULSE Setpoint and "PRV Position Override" is displayed as Control Status.

VGD Limit Switch

The status of the Variable Geometry Diffuser Limit Switch is now displayed on the VGD Screen and the VGD Setpoints Screen. The Limit Switch is closed and displayed as CLOSED when the VGD is in the full closed position. Otherwise, it is displayed as OPEN.

Motor Lubrication Notification

This feature provides an indication when the compressor motor lubrication is required. The notification is based on the "Operating Hours Since Last Motor Lubrication". Up to three levels of notification are provided, each indicating an increasing level of urgency. "Warning – Motor Bearing Lube Suggested" is displayed when the hours exceed 1000 hours. If there is no response, "Warning – Motor Bearing Lube Required" is displayed when the hours exceed 1200 hours. If there is still no response, a safety shutdown is performed when the hours exceed 1400 hours and "Motor – Lack of Bearing Lubrication" is displayed. The Operator enters his/her initials, name or user ID to provide a record of when a motor lubrication is performed and clear any motor lubrication warning or safety that is in effect.

Condenser Refrigerant Level Control

In previous software versions, all of the control thresholds were programmable. In this version, some control thresholds are fixed while others are programmable. This provides more stable control in certain operating conditions. The control thresholds are applied in two different zones, as determined by the error relationship between the actual refrigerant level and the Level Setpoint as shown below. Zone 1 parameters are used when the error is < 9%. Zone 2 parameters are used when the error is > 9%. When transitioning from Zone 2 to Zone 1, the error must be < 9% for 60 seconds before the Zone 1 parameters are used. If the error is > 9%, the Zone 2 parameters are immediately implemented. The following are the control thresholds now used for this control:

160.54-M1 (LS05) SOFTWARE ENHANCEMENTS EFFECTIVE MARCH 2005 (CON'T)

	<u>Zone 1</u>	<u>Zone 2</u>
Proportion Limit Open (fixed)	50%	52%
Proportion Limit Close (fixed)	45%	45%
Rate Limit (setpoint)	3%-15%	3%-15%
	default 7	default 5
Period (setpoint) (seconds)	8-22	2.5-10
	default 15	default 2.5
	<u>Zone 1 and Zone 2</u>	
Level Setpoint	20% to 80%	
	default 30%	
Valve Preset Time (setpoint) (seconds)	0 to 100	
	default 50	
Ramp Up Time (setpoint) (minutes)	3 to 15	
	default 8	

Compressor Protection Faults

The following compressor protection faults have been added:

“Motor – Current >15% FLA”

In this version, the start inhibit is instantaneously invoked as soon as >15% FLA motor current is detected while the chiller is shutdown. Previously, it was not put into effect until the invalid motor current was present for at least 10 seconds.

“VSD – FREQUENCY > 0Hz”

This new Start Inhibit is set whenever the chiller is shutdown and a compressor motor Variable Speed Drive (VSD) Output Frequency of greater than 0Hz is detected.

“VSD – LOW FREQUENCY DETECTED”

This new safety shutdown is set whenever the chiller is running and the compressor motor Variable Speed Drive (VSD) Output Frequency decreases to less than half speed (25Hz for 50Hz units; 30Hz for 60Hz units) after having reached that speed while starting.

Standby Lubrication

In low ambient temperature conditions, oil foaming when the pump is first turned on results in a sawtooth pressure ramp until it establishes a steady pressure. Although the pressure builds to 15 PSID within seconds at pump turn-on, a subsequent negative transition below 15 PSID within the first 30 seconds is detected as a Standby Lube failure. In this software version, the low oil pressure threshold is not applied until after the first 30 seconds of oil pump operation. This allows sufficient time to establish steady pressure above 15 PSID.

Optisave KW Metering Feature

This feature provides customers currently employing a solid state starter or electro-mechanical starter with the means to determine their potential savings that would be realized by switching to a variable speed drive.

Variable Speed Oil Pump (manual control)

In previous software versions: “The LOWER key causes a decrease in the command frequency by the Manual Increment Amount, down to the Manual Increment Amount”. In this version: “The LOWER key causes a decrease in the command frequency, by the Manual Increment Amount, down to 25/30Hz”.

SI0148 - SOFTWARE ENHANCEMENTS EFFECTIVE JUNE 2006**General**

Beginning June 2006, enhanced software will be supplied in new production YK chillers. It is backward compatible to all previous YK chillers equipped with microboard 031-02430-000 or 031-02430-001. The enhancements are outlined below.

The versions and part numbers are:

Microboards 031-02430-000 and 031-02430-001

- NEMA 1-4 and CE chillers C.OPT.01.15.011 (031-02474-001)

Medium Voltage Solid State Starter

This software version is necessary for Medium Voltage Solid State Starter applications.

575V/60Hz Variable Speed Drive

This software version is necessary for 575V/60Hz VSD applications.

The following Cycling shutdowns apply to 575V/60HZ VSD:

“VSD-PRECHARGE-LOW DC BUS VOLTAGE”

If the DC Link voltage does not reach at least 60VDC (within 4 seconds) or at least 600VDC (within 20 seconds) after the precharge command has been received, this shutdown is performed.

“VSD—PRECHARGE-DC BUS VOLTAGE IMBALANCE”

If the Half DC Link voltage does not remain within + 106VDC of the DC Link Voltage divided by 2 during the pre-charge interval, this shutdown is performed.

“VSD-LOW DC BUS VOLTAGE”

If the DC Link Voltage falls below 600VDC while running, this shutdown is performed.

“VSD-DC BUS VOLTAGE IMBALANCE”

If the Half DC Link Voltage does not remain within + 106VDC of the DC Link Voltage divided by 2 while running, this shutdown is performed.

“VSD-HARMONIC FILTER-PRECHARGE-LOW DC BUS VOLTAGE”

If the DC Link voltage does not reach at least 60VDC (within 100 milliseconds) or at least 630VDC (within 5 seconds) after the filter precharge command has been received, this shutdown is performed.

“VSD-HARMONIC FILTER-DC BUS VOLTAGE IMBALANCE”

If the Half DC Link Voltage does not remain within + 63 VDC of the DC Link Voltage divided by 2, this shutdown is performed.

The following safety shutdowns apply to 575v/60Hz VSD:

“VSD-HARMONIC FILTER-HIGH BASEPLATE TEMPERATURE”

If the Baseplate temperature rises above the following limits, this shutdown is performed:

424HP – 70.0° F, 174.2° C

608HP – 88.0° F, 190.4° C

Microboard Applicability

This software will operate in microboard 31-02430-000 or 031-02430-001. However, this version (or later versions) are required for microboard 031-02430-001. Refer to Literature Supplement 160.54-M1 (LS06)

SI0158 - SOFTWARE ENHANCEMENTS EFFECTIVE OCTOBER 2006

General

Beginning October 2006, enhanced software will be supplied in new production YK chillers. It is backward compatible to all previous YK chillers equipped with microboard 031-02430-000 or 031-02430-0001. The enhancements are outlined below.

The versions and part numbers are:

- NEMA 1-4 and CE chillers: C.OPT.01.15A.307 (031-02474-001)

Languages

Version C.OPT.01.15.011 was released as English only. This version allows display in English, Chinese Traditional, Chinese simplified, French, Spanish, Italian, German or Hungarian language.

SI0164 - SOFTWARE ENHANCEMENTS EFFECTIVE APRIL 2007

General

Beginning April 2007, enhanced software will be supplied in new production YK chillers and replacement microboard kit 331-02430-601. This software is backward compatible to all previous YK chillers equipped with microboard 031-02430-000 or 031-02430-001. The enhancements are listed below.

The versions and part numbers are:

- NEMA 1-4 and CE chillers: C.OPT.01.16.xxx (031-02474-001)

Selectable Coastdown Time Setpoint

To assure bearing lubrication until the compressor motor stops rotating at chiller shutdown, the oil pump runs for the duration of the coastdown period. Larger motors require a longer coastdown time than the standard 150 seconds. Therefore, when "Standard" is selected for the COASTDOWN Setpoint on the Setup Screen, new setpoint COASTDOWN TIME allows the service technician (in Service Access Level) to enter a coastdown time appropriate for the motor applied. The time is programmable over a range based on the selection made for the CHILLER STYLE/COMPRESSOR Setpoint on the Operations Screen: For style F/J7 and G/K6-K7, the range is 240 (Default) to 900 seconds. For all others, the range is 150 (Default) to 900 Seconds.

Chilled and Condenser Water – Flow Switch Shutdowns

To prevent nuisance flow switch shutdowns due to momentary flow interruption or rapid water temperature changes that can affect Thermal Flow Sensors, the following extended flow switch delays are implemented for both ANALOG and DIGITAL flow sensor selections:

"Leaving Chilled Liquid – Flow Switch Open" – The chilled water flow switch has remained open for 5 continuous seconds (2 continuous seconds with software version C.OPT.01.15A.xxx and earlier) while the chiller is running or failed to close during the Pre-Lube period. The chiller will automatically restart when the flow switch closes.

"Condenser – Flow Switch Open" – The condenser flow switch has remained open for 30 continuous seconds (2 continuous seconds with software version C.OPT.01.15A.xxx and earlier) while the chiller is running. This check is bypassed for the first 30 seconds of "System Run".

Current Imbalance Messages

The safety shutdown messages "Motor or Starter – Current Imbalance" and "LCSSS – Output Current Imbalance" have been combined into one message "Motor or Starter – Output Current Imbalance" for both Variable Speed Drives and Style B Solid State Starters.

New Trend/Custom View Slot Numbers

The following slot numbers have been added:

- 2849 ACC Surge Count
- 2850 ACC Surge Type
- 2857 ACC Surge Point Count
- 2858 ACC Surge Delta P/P
- 2859 ACC Surge Output Frequency
- 2860 ACC Surge PRV Position

Trend Scaling Error Correction

In previous software versions, the software automatically rescaled the Y-axis range (on certain parameters) after the operator had already selected the range. This could result in reducing the overall range. The Y-axis is now scaled to accommodate the highest value selected.

Variable Speed Drive – Invalid Current Limit Message

In previous software versions, when operating at <full speed (60Hz/50Hz) and pressing the FIXED key on the VSD Tuning Screen, the message "Motor – High Current Limit" was displayed until the drive reached full speed. While this message was displayed, the PRV are inhibited from opening.

In this version, "Load Control Mode" is displayed instead of "Motor – High Current Limit" under this condition.

The compressor motor Variable Speed Drive has not yet reached full speed after having been commanded to do so in manual speed control. While this is displayed, the Pre-rotation Vanes are inhibited from further opening.

New Chiller Style/Compressor Selections

The existing selections are changed as follows:

- | <u>Existing</u> | <u>Change to</u> |
|---------------------|------------------------|
| Style F/J, H3 compr | Style F/J1-J5H3 compr |
| Style F/PQH9 compr | Style F & G/PQH9 compr |

SI0164 - SOFTWARE ENHANCEMENTS EFFECTIVE APRIL 2007 (CON'T)

The following new selections are added on the OPERATIONS Screen:

- Style F/J7 compr
- Style G/K1-K4 compr
- Style G/K6-K7 compr

Functionally, these new selections are the same as Style F/J1-J5H3: Proximity Sense = Probe, Oil Heater Output = TB1-64, Level Control Period = 3.5 seconds Flow Switch = Programmable (analog or digital), Variable Speed Drive Oil Pump “Pressure Setpoint not achieved” = 35 PSID

Motor Lubrication Warnings and Shutdown

This software version adds the AUTO LUBE and SHUTDOWN setpoints on the Motor Screen. Chillers that are equipped with Automatic Motor Lubrication hardware do not require manual lubrication and therefore do not require the motor lubrication warnings (reminders) or the warning safety shutdown. Therefore, when the automatic lubrication hardware is present, the AUTO LUBE Setpoint must be ENABLED. With this setting, no lubrication warnings or shutdown will occur.

If the AUTO LUBE setpoint is DISABLED, as it should be when not equipped with the automatic Motor Lubrication hardware, the motor lubrication warnings and shutdown will occur at the associated elapsed run times. With this setting, the SHUTDOWN Setpoint is used to enable or disable the safety shutdown that occurs at 1400 hours since last lubrication. The safety shutdown can be enabled or disabled per the customer’s preference. If enabled, the safety shutdown will occur at the normal 1400 hours. If disabled, a warning will be displayed but the safety shutdown will not occur.

Microgateway - Motor Lubrication Warning Code Correction

Previous software versions send an incorrect warning code to the Microgateway for the Motor Lubrication Warning “Motor – Bearing Lube Suggested”. They send a code 5, which is “Condenser – High Pressure Limit”. This error is corrected in this software version. The new codes sent to the Microgateway are:

“Motor-Bearing Lube Suggested” – Warning Code 36

“Motor-Bearing Lube Required” – Warning Code 37

“Motor-Lack of Bearing Lubrication” – Warning Code 38

Medium Voltage Variable Speed Drive

When used with microboard 031-02430-001, this software supports the Medium Voltage Variable Speed Drive (MV VSD). Refer to YORK Operator Manual 160.00-06 and Service Manual 160.00-M6 for this product.

Since the MV VSD does not save snapshot data when faulting, History Reports do not include snapshot data of shutdowns. Report contains only motor run state, PRV position and MV VSD fault code.

Motor Communications Protocol Setpoint

On new production chillers prior to March 2007, the VSD Adaptive Capacity Control (ACC) Board communicates with the Microboard COM5 serial port using YORK protocol. After this date, on new production chillers, the ACC functionality is contained in the Microboard and the ACC Board is not present. On these chillers, the VSD Logic Board communicates directly with the Microboard COM2 serial port using Modbus protocol. To allow this software to accommodate new production chillers and earlier chillers, this software allows selection of either YORK or MODBUS protocol when VSD-50Hz/VSD-60Hz is selected for the Motor Drive Type Setpoint. When used with Modbus protocol, microboard 031-02430-001 is required (ref SI0155). The protocol selection enables the appropriate serial communication port: “YORK” enables COM5; “MODBUS” enables COM2. The hardware present determines which protocol should be selected (ref SI0155): If the ACC Board is used, select “YORK”. Otherwise, select “MODBUS”.

With Modbus protocol, the device that the microboard serially communicates with is assigned an address. On VSD applications, this device is the VSD Logic Board. Whenever the microboard is reading or writing to this board, it transmits this address. If the transmitted address matches the address assigned, the Logic Board responds. Otherwise, it ignores the command/request. The address assigned to the VSD Logic Board is “1”. This is done by the positioning the VSD Logic Board Modbus Address Switch SW3 position 1 to ON and setting the

SI0164 - SOFTWARE ENHANCEMENTS EFFECTIVE APRIL 2007 (CON'T)

Motor Node ID setpoint to “1”. If these two values are not set to the same number, the VSD Logic Board will not communicate with the microboard.

The following new setpoints are programmed on the SETUP Screen:

“Motor Communications Protocol”

Access Level Required: SERVICE

Only displayed when VSD-60Hz or VSD-50Hz is selected for Motor Drive Type Setpoint. Allows Service Technician to enable the appropriate serial communications port for communications to the Variable Speed Drive. Entered as “York” to enable COM5 (J15) or “Modbus” to enable COM2 (J13). Selection is based on hardware and interface. If ACC Board is used, select “YORK”. Otherwise, select “MODBUS”. Microboard 031-02430-001 must be equipped with 128KB BRAM (031-02565-000) to select “Modbus”. Chiller must be stopped with the Start-Run-Stop switch in the Stopped position to change this setpoint.

“Motor Node ID”

Access Level Required: SERVICE

Only displayed when “Modbus” is selected for the Motor Communications Protocol Setpoint above. Allows the Service technician to enter the Modbus Address of the VSD Logic Board. Must be set to “1”. The VSD Logic Board Modbus Address switch SW3 must also be set to “1”. Chiller must be stopped with the Start-Run-Stop switch in the Stopped position to change this Setpoint.

The following screens are affected by this new protocol selection:

Comms Screen

When Modbus Comms are selected, the COM2 Setup key on the COMMS Screen is not displayed.

Modbus Diagnostics Screen

When Modbus Protocol is selected, the VSD COMMS Screen is replaced by the DIAGNOSTICS VSD (Modbus) Screen. A reset counters key is present allowing the error counters to be reset to zero. This screen displays the following Modbus communications error counters:

- Panel to VSD
- VSD to Panel
- FTR to VSD (if IEE 519 filter present and enabled)

SI0186 - SOFTWARE ENHANCEMENTS EFFECTIVE OCTOBER 2006

General

Beginning March 2008, enhanced software will be supplied in new production YK chillers and replacement microboard kit 331-02430-601. This software is backward compatible to all previous YK chillers equipped with microboard 031-02430-000 or 031-02430-001. The enhancements are listed below.

The versions and Program Card part number is:

- NEMA 1-4 and CE chillers: C.OPT.01.18.307 (031-02474-001)

Liquid Cooled Solid State Starter – Motor Communications Protocol Setpoint

This software supports both YORK and MODBUS protocol versions of the serial communications between the Microboard and the Solid State Starter Logic/Trigger Board. Although this software version supports both protocols, the Logic/Trigger Board will not be converted to MODBUS capability until later in mid 2008.

In new production chillers prior to mid 2008, microboard COM 5 port (J15) communicates with the LCSSS Logic/Trigger Board (031-02001 or 031-02505) (TB2) using YORK protocol. In new production chillers beginning mid 2008, the microboard RS-485 COM 2 port (J13) will communicate with the Logic/Trigger Board (031-02505) (J14) using MODBUS protocol.

The protocol and motor drive type selection is made on the SETUP Screen, using SERVICE access level. When “SSS-Mod B” is selected as the MOTOR DRIVE TYPE setpoint, the MOTOR COMMUNICATIONS PROTOCOL setpoint is used to select either YORK or MODBUS protocol, as appropriate. The appropriate selection depends on the actual hardware/interface that is present as per above. As a guide, the starter Logic/Trigger Board is not scheduled to be converted to MODBUS capability in new production chillers until mid 2008. A Service Information Letter will be issued at that time defining the hardware/interface/setup requirements for MODBUS protocol.

Oil Pressure Safety – R22 Applications

When the refrigerant selection (microboard SW1-1) is set to “R22” and the Oil Pump Package (Setup Screen) is set to “Variable Speed”, the “Oil-Variable Speed Pump-Setpoint Not Achieved” safety shutdown is not performed.

Medium Voltage VSD

11KV, 12.47KV and 13.8KV applications are supported.

“Oil-Low Temperature Differential” Cycling Shutdown

When the chiller has been shutdown for < 30 minutes, a restart should be allowed when the oil temperature minus the condenser saturation temperature is > 30°F. In previous software version, this threshold was erroneously set to 40°F.

“Leaving Chilled Liquid-Low Temperature” Shutdown Offset

The Low Temperature shutdown threshold is programmed as an offset below the LEAVING CHILLED LIQUID TEMPERATURE setpoint using the SHUTDOWN setpoint. In previous software versions, this value was displayed as the OFFSET on the upper right area of the Evaporator Screen. However, it did not always accurately reflect the actual offset being used by the software.

SI0186 - SOFTWARE ENHANCEMENTS EFFECTIVE OCTOBER 2006 (CON'T)

In this version, OFFSET will be replaced with EFFECTIVE OFFSET and will automatically change to reflect the actual offset being used. Usually, the Offset used is the same as the value programmed for the SHUTDOWN setpoint. However, the Offset being used will automatically change, based on the values programmed for the LEAVING CHILLED LIQUID TEMPERATURE setpoint and the SHUTDOWN setpoint, to prevent the leaving chilled liquid temperature from going below the minimum allowed value: 36°F (water), 34°F (water with smart freeze enabled) or 6°F (brine). For example, if it is set to 45°F (water) and the SHUTDOWN setpoint is set to 4°F, the Effective Offset is displayed as 4°F. If the leaving setpoint is lowered to 38°F, the Effective Offset will change to 2°F. If the the leaving chilled setpoint is raised back to 45°F, the Effective Offset will revert back to the SHUTDOWN setpoint.

Analog Remote Setpoints Filtering

This software version provides filtering on the Analog Leaving Chilled Liquid Temperature Setpoint and the Current Limit Setpoint inputs. This stabilizes these remote setpoint values under noisy conditions and when the inputs are unstable.

Remote Reset Temperature Range Setpoint

In previous software versions, this setpoint could be set to 10°F or 20°F. In this version it can be set to 10°F, 20°F, 30°F, or 40°F.

This page intentionally left blank.

SI0201 - SOFTWARE ENHANCEMENTS (VER 19) EFFECTIVE OCTOBER 2008

General

Beginning October 2008, enhanced software will be supplied in new production YK chillers and replacement microboard kit 331-02430-601. This software is backward compatible to all previous chillers equipped with microboard 031-02430-000 or 031-02430-001. The enhancements are listed below.

The version and Program Card part number is:

- NEMA 1-4 and CE chillers: C.OPT.01.19.307 (031-02474-001)

ACC and Surge Detection Display Enhancements

With the integration of the Variable Speed Drive Adaptive Capacity Control (ACC) function into the Microboard (in software version C.OPT.01.16.307), it is necessary to add screens and LED indicators and additional parameters to certain screens to compensate for the loss of ACC Board indicators.

The parameters displayed on the following screens now vary according to the selection made for the Motor Communications Protocol Setpoint on the SETUP Screen. It is set to either YORK or MODBUS, as determined by the existing hardware/interface. The correct selection must be made in order for the microboard to communicate with the drive, as explained below. Service technicians should refer to Optiview Service Manual 160.54-M1 to determine existing hardware/interface configuration.

In new production chillers prior to March 2007, the Microboard communicates with the VSD Logic Board via the ACC board using YORK protocol serial communications. In this configuration, the ACC function is performed by the ACC Board. The Motor Communications Protocol Setpoint must be set to YORK in this configuration. This configuration is referred to below as “York protocol configuration”. After this date, the Microboard communicates directly with the VSD Logic Board using MODBUS protocol serial communications and the ACC Board is not present. In this configuration, the ACC function is performed by the Microboard. The Motor Communications Protocol Setpoint must be set to MODBUS in this configuration. This configuration is referred to below as “MODBUS protocol configuration”. All MV VSD applications use MODBUS protocol. Due to service parts replacement, early production chillers could be in the MODBUS configuration.

With the integration of the ACC function into the microboard, there are now two surge detection features. Although they use the same detection logic, each has its own Sensitivity setpoint and each one performs detection based on the starter type.

1. The existing Surge Protection feature detects surges for Surge Avoidance and Hot Gas Bypass and uses the Surge Sensitivity setpoint on the Surge Protection Screen. If equipped with a Solid State Starter or Electro-mechanical starter, this feature detects all surges. If equipped with a VSD (in YORK or MODBUS protocol configuration) or MV VSD, it only detects those surges that occur while the drive is running at maximum frequency. The Surge Avoidance Surge Count increments each time a surge is detected by the Surge Protection feature.
2. The ACC function in the microboard (in Modbus protocol configuration) uses the Sensitivity setpoint on the ACC Details Screen and detects only those surges that occur while the VSD or MV VSD is running at less than maximum frequency. When these surges are detected, the ACC Surge Count is incremented. This surge detection is used to determine if the VSD can reduce speed.

SI0201 - SOFTWARE ENHANCEMENTS (VER 19) EFFECTIVE OCTOBER 2008 (CON'T)

VSD Tuning Screen

This screen is now as shown in 160.54-O1 (1208) FIG. 14. The following data boxes are added:

- “% Full Load Amps” – Displays the motor current as a percentage of chiller full load amps as calculated by the microboard from current values returned from the drive Logic Board.
- “Command Frequency” – In MODBUS protocol configuration, this is the speed command being sent to the Drive Logic Board in either AUTO or MANUAL speed control mode. In YORK protocol configuration, it is only displayed in manual speed control mode and it is the speed command being sent from the Microboard to the ACC Board in Manual Speed Control mode.

The “Incr Amount” key is renamed “Manual Increment”. This key now only applies to manual speed control mode. It defines the amount by which the manual Raise and Lower commands will change the Command Frequency to the VSD in manual speed control mode.

Adaptive Capacity Control Details Screen (Modbus Configuration)

160.54-O1 (1208) FIG. 22B shows this screen in MODBUS Protocol configuration. The following data boxes are added:

- “Temperature Differential (LCHLT – Setpoint)” - Displays the difference between the Leaving Chilled Liquid Temperature and the Leaving Chilled Liquid Temperature Setpoint
- “Command Frequency” – Displays the speed command being sent to the Drive Logic Board in either AUTO or MANUAL speed control mode.
- “Surge Map Point Count” – Displays the total number of data points contained in the surge map
- “ACC Surge Count” – Increments when a surge is detected while the drive is running at less than maximum frequency.

The following LED indicators are added:

- “Speed Decrease Inhibit – Surge Map Point” – Illuminates when the ACC function in the microboard is unable to reduce speed due to a mapped surge point. Otherwise, it is extinguished.
- “Mapping Inhibited” – Illuminates while the ACC function in the microboard is not allowed to map (i.e., not allowed to slow down as well) points due to unstable leaving chilled liquid temperature, manual speed control or current limit (chiller FLA only). Otherwise, it is extinguished. The logic to control this is the same as used for the VPT LED (CR8) on the ACC Board. Refer to 160.00-M4.
- “ACC Surge Detected” – Illuminates momentarily when a surge is detected by the ACC function in the microboard, while the drive is running at less than maximum frequency.
- “Surge Avoidance Surge Detected” – Illuminates momentarily when a surge is detected by the Surge Protection feature. This feature only detects surges that occur while the drive is running at maximum frequency.

Adaptive Capacity Control Details Screen (YORK Protocol)

The following Setpoint Keys are removed from this screen:

- Local Motor Current Limit
- Pulldown Demand Limit
- Pulldown Demand Time

The following navigation keys are added:

- Surge Map – Move to the sub-screen that displays the surge map. Only appears at Service (or higher) Access Level.

The Manual Surge Point Key

When this key is pressed, a dialog box appears that asks for a password. Once password 0 3 6 8 has been entered and the Enter key has been pressed, the present operating condition is logged into the surge map as a valid surge point. The chiller must be running to enter the point.

SI0201 - SOFTWARE ENHANCEMENTS (VER 19) EFFECTIVE OCTOBER 2008 (CON'T)

160.54-O1 FIG 22A shows the ACC details screen in YORK protocol configuration. The following data boxes are added:

- “Temperature Differential (LCHLT – Setpoint)” - Displays the difference between the Leaving Chilled Liquid Temperature and the Leaving Chilled Liquid Temperature Setpoint
- “Command Frequency” - It is only displayed in manual speed control mode and it is the speed command being sent from the Microboard to the ACC Board in Manual Speed Control mode.
- “ACC Surge Count” – Count is provided by the ACC Board and it increments when any surge is detected by the ACC Board, whether running at maximum or less than maximum frequency.

The following Setpoint Keys are removed from this screen:

- Local Motor Current Limit
- Pulldown Demand Limit
- Pulldown Demand Time

The Manual Surge Point Key

When this key is pressed, a dialog box appears that asks for a password. Once password 0 3 6 8 has been entered and the Enter key has been pressed, the present operating condition is logged into the surge map as a valid surge point. The chiller must be running to enter the point.

Surge Map Screen

When in MODBUS protocol configuration, there is now a Surge Map Screen that displays the surge map in either TABLE or LIST form, as selected with the MAP VIEW key on the Surge Map Screen.

With the MAP VIEW set to TABLE, as shown in 160.54-O1 FIG. 22C, the map is shown graphically. The X-axis is Delta P/P and the Y-axis is PRV position. Each VSD frequency point is represented by an “X” in the table. The Present Operating conditions are indicated with an “*” and are detailed at the bottom of the screen under PRESENT, as shown in 160.54-O1 FIG. 22C. If the present condition is the same as a mapped point, the “*” will be replaced by an “O”. To view the details of any mapped point, position the green box (□) over the desired “X” using the keypad arrow keys (▲ ▼ ◀ ▶). The VSD Output Frequency, Pre-rotation Vanes Position and Delta P/P of the selected point is displayed at the bottom of the screen under SELECTED. The default position for the green box is in the upper left corner of the view window. Once moved, it will remain at the last position. The Speed Decrease Inhibit-Surge map Point LED, Mapping Inhibited LED and ACC Surge Detected LED are also on this screen. They function the same as the duplicate LED’s on the ACC Details Screen

With the MAP VIEW set to LIST, as shown in 160.54-O1 FIG. 22D, the Delta P/P, PRV Position and VSD Output Frequency of each mapped point are listed in rows. This is the same report that is generated when the surge map is sent to a printer. Therefore, this view cannot be selected while a print is in process. The PAGE UP and PAGE DOWN keys are used to scroll to the previous or next listing.

SI0201 - SOFTWARE ENHANCEMENTS (VER 19) EFFECTIVE OCTOBER 2008 (CON'T)

Hot Gas Bypass Screen

The Hot Gas Bypass Control Mode data box on this screen now displays “Minimum Load”, “VSD Override” or “VGD Override” based on the actual override in effect. Previously, “Override” was displayed as a general message for any of these conditions. Refer to override descriptions in Optiview Service Manual 160.54-M1.

In previous software versions, when the drive was running less than full speed, normal hot gas operation, including the “Minimum Load” operation was overridden and the hot gas bypass valve was driven to the fully closed position. In this version, the “Minimum Load” function is allowed to operate even when the VSD is at less than full speed. The “Minimum Load” function opens the hot gas bypass valve to the maximum allowed by the MAXIMUM OPEN setpoint (25% to 100%) when the Leaving Chilled Liquid Temperature decreases to less than the MINIMUM LOAD Setpoint, programmed as an offset below the Leaving Chilled Liquid Temperature Setpoint. Refer to 160.54-M1.

The “Surge Detected” LED is replaced by a “Surge Avoidance Surge Detected” LED. It illuminates momentarily when a surge is detected by the Surge Protection feature (see below). If equipped with a VSD (YORK or MODBUS protocol configuration) or MV VSD, this feature only detects surges that occur while the drive is running at maximum frequency.

An “ACC Surge Detected” LED is added to this screen when in MODBUS protocol configuration. It illuminates momentarily when a surge is detected by the ACC function in the microboard. These are surges that are detected while the drive is running at less than maximum frequency.

The SURGE AVOIDANCE SURGE COUNT is the total surges accumulated by the Surge Protection feature. If equipped with a Liquid Cooled Solid State Starter or Electro-mechanical starter, it is the total surges detected. If equipped with a VSD (YORK or MODBUS protocol configuration) or MV VSD, it is only the surges detected while the drive is running at maximum frequency.

160.54-O1 FIG. 11 shows this screen in MODBUS Protocol configuration.

Surge Protection Screen

The CLEAR SURGE COUNT key was removed in the previous software version. It is re-instated in this version. It clears the Surge Avoidance Surge Count of the Surge Protection feature using an ADMIN password. If equipped with a Liquid cooled Solid State Starter or Electro-mechanical Starter, these are the total surges detected. If equipped with a VSD (YORK or MODBUS protocol configuration) or MV VSD, these are the total surges detected while the drive was running at maximum frequency.

The “Surge Detected” LED is replaced by a “Surge Avoidance Surge Detected” LED. It illuminates momentarily when a surge is detected by the Surge Protection feature. If equipped with a VSD (YORK or MODBUS protocol configuration) or MV VSD, this feature only detects surges that occur while the drive is running at maximum frequency.

An “ACC Surge Detected” LED is added to this screen when in MODBUS protocol configuration as shown in 160.54-O1 FIG. 12. It illuminates momentarily when a surge is detected by the ACC function in the microboard. These are surges that are detected while the drive is running at less than maximum frequency.

The SURGE AVOIDANCE SURGE COUNT is the total surges accumulated by the Surge Protection feature. If equipped with a Liquid Cooled Solid State Starter or Electro-mechanical starter, it is the total surges detected. If equipped with a VSD (YORK or MODBUS protocol configuration) or MV VSD, it is only the surges detected while the drive is running at maximum frequency.

SI0201 - SOFTWARE ENHANCEMENTS (VER 19) EFFECTIVE OCTOBER 2008 (CON'T)

The SURGE SENSITIVITY key allows the Service Technician to adjust the sensitivity of the surge detection of the Surge Protection Feature (Surge Avoidance Surge Detection). Programmable over the range of 0.3 (default) to 1.3. Smaller values increase the sensitivity. If equipped with a Liquid Cooled Solid State Starter or Electro-mechanical starter, these are the total surges detected by this feature. If equipped with a VSD (YORK or MODBUS protocol configuration) or MV VSD, these are the surges that are detected while the drive is running at maximum frequency.

Trending

In previous software versions, the Evaporator Small Temperature Difference and Condenser Small temperature Difference were both labeled "Small Temperature Difference". In this version, they are labeled as "Evaporator Small Temperature Difference" and "Condenser Small Temperature Difference".

There are now always a maximum of 20 divisions on the Y-axis, regardless of Access Level. In previous software versions, there was sometimes a maximum of 23 in Service Mode and sometimes 20 divisions in View Mode.

Italian Language Corrections

The Italian translations of the following messages have been corrected in this software version:

"Condenser-Pressure Transducer out Of Range", "VSD-Low Converter Heatsink Temperature", "Control Panel-Power Failure", Refrigerant Level Control Screen-"Set Zone", Setup Screen-"Change Settings", History Screen "Vane Motor Switch Open", Slots Screen "Small Temperature Difference", History Screen-"Leaving Chilled Liquid – Flow Switch Open"

ACC Corrections/Enhancements

Frequency Command - In previous software versions, there were certain conditions (such current limit) under which an incorrect frequency command was sent to the VSD. This has been corrected in this version.

Frequency Command Increase - To assure that VSD or MV VSD frequency increases do not cause excessive motor current resulting in overload shutdowns, frequency increase limitations are imposed based upon how close the actual motor current is to the chiller full load amps.

In Automatic Frequency Control mode, anytime the microboard ACC function increases the VSD or MV VSD output frequency, the frequency increase is limited by the motor current as follows:

- When Motor Current \leq 80% FLA: No Limiting
- When Motor Current $>$ 80% FLA and \leq 98% FLA: Increase 0.1Hz every $\{2 + (\%FLA-80)\}$ seconds
- When Motor Current $>$ 98% FLA: Increase 0.1Hz every 20 seconds

Although the incremental frequency increases can be less than allowed, they will never be greater than allowed. These limitations also apply to the frequency ramp that occurs at chiller start while ramping from start frequency 30Hz (60Hz applications) or 25Hz (50Hz applications) to maximum frequency. These limitations are not imposed in Manual Frequency Control.

Surge Detection and Reaction During Chiller Start - The surge detection and reaction routine is now disabled until 5 seconds after the start frequency (25Hz for 50Hz applications/30Hz for 60Hz applications) is achieved. This prevents false or transient surge conditions from being logged or reacted to.

Extended Condenser Temperature Range

Certain applications must operate at higher condenser temperatures. The maximum allowable condenser temperature is increased from 116°F to 128°F. The resulting higher operating pressures require higher warning and safety shutdown thresholds than are in previous software versions.

SI0201 - SOFTWARE ENHANCEMENTS (VER 19) EFFECTIVE OCTOBER 2008 (CON'T)

To allow this software version to be used in both the standard and the higher temperature applications, a CONDENSER TEMPERATURE RANGE setpoint is added to the Setup Screen as shown in 160.54-O1 FIG. 27 to allow selection of either “Standard” (default) or “Extended”. This setpoint is set at the factory and requires an ADMIN password to change it. It is only visible when set to “extended”.

When set to “Standard”, the following warning and safety shutdown thresholds are unchanged. When set to “Extended”, they are as follows:

- “Warning – High Pressure Limit” - Maximum allowable value is 193.0 PSIG, with no change to the default value
- “Condenser – High Pressure” - Trip/Reset threshold is 200/140 PSIG
- “Condenser – High Pressure – Stopped” – Trip/Reset threshold is 170 PSIG

To accommodate the higher temperatures, these chillers will be equipped with a different High Pressure Cutout Switch (HPCO) that can be set to trip at a higher pressure.

VGD Setpoint Defaulting Correction

In previous software versions, the PRV-VGD INHIBIT Setpoint (40% to 100%) would reset to its default value (95%) upon power-up following a power failure. This software version correctly maintains the last programmed value.

Refrigerant Level Control

The Level Control Setpoint default has been changed from 30% to 50%.

Trend Setup Screen

This software version fixes a problem that prevents the Y-Axis maximum allowed display values in all 6 data points to be set in Metric Mode.

Program Card Downloading

Although the procedure has not changed, the program downloading has been modified to reduce the download time.

Medium Voltage Variable Speed Drive – Variable Maximum Values

The following MVVSD variables are now allowed to be a maximum value of 65,535:

- MVVSD Bus Voltage
- MVVSD Output Current (3 phases)
- MVVSD Input Voltage
- MVVSD Output Voltage

SI0210 - SOFTWARE ENHANCEMENTS (VER 20) EFFECTIVE JUNE 2009

General

Beginning June 2009, enhanced software will be supplied in new production YK chillers and replacement micro-board kit 331-02430-601. This software is backward compatible to all previous chillers equipped with microboard 031-02430-000 or 031-02430-001. The enhancements are listed below.

The software version and Program Card part number is: C.OPT.01.20.307 (031-02474-001)

Medium Voltage Variable Speed Drive

The following new features are added:

New Data Values

The following new values are now read from the MV VSD:

- Programmed Maximum Drive Output Frequency
- Programmed Motor Power Rating

<u>Modbus Address</u>	<u>Name</u>	<u>Scale</u>
40033	Rated Output Voltage	x10
40034	Rated Output KW	x10
40058	Rated Output Frequency(History Data)	x10
40059	Rated Output KW(History Data)	x10

MV VSD Model

The MV VSD Model is displayed on the MV VSD Drive Screen in the data box labeled “MV VSD Model” as a number representing the horsepower rating followed by “HP” (ie; 1500HP). The model number is derived from the Motor Rated Voltage (Modbus Address 40012) and the Programmed Drive Current (Modbus Address 40013) according to the following table. If this results in a model that is not defined in the lookup table, the model number is displayed as “INVALID” and the chiller will not be allowed to run while this is displayed.

Motor Rated Voltage (V)				
		2300 V	3300 V	4160 V
Model in HP	500	107 A	78 A	62 A
	600	129 A	93 A	74 A
	700	157 A	110 A	87 A
	800	172 A	124 A	99 A
	900	202 A	141 A	112 A
	1000	224 A	156 A	125 A
	1250	280 A	195 A	155 A
	1500	336 A	235 A	186 A
	1750	392 A	274 A	217 A
	2000	438 A	312 A	248 A
	2250	494 A	345 A	274 A
	2500	561 A	391 A	310 A

Max. Job/Rated 100% FLA (A) (Programmed Drive Current)

SI0210 - SOFTWARE ENHANCEMENTS (VER 20) EFFECTIVE JUNE 2009 (CON'T)

Full Load Amps Setpoint (Maximum Value)

The maximum allowed programmable value of the “Full Load Amps” Setpoint on the MV VSD Screen is now set to the PROGRAMMED DRIVE CURRENT (Modbus Address 40013) value received from the MV VSD. In previous software versions, it was derived from a lookup table based on the MOTOR RATED VOLTAGE and MV VSD Model.

Motor Voltage Rating

On the MV VSD Screen, the “Voltage Rating” display has been changed to read “Motor Voltage Rating”. Displayed in Volts, as received from the MV VSD. If any invalid “Motor Voltage Rating” is received from the MV VSD, “INVALID” is displayed and the chiller will not be allowed to run while this is displayed.

Output Frequency Rating

A new data box is added to the MV VSD Screen labeled “Output Frequency Rating”. The rated output frequency (Modbus Address 40033), as received from the MV VSD, is displayed here. This value is the maximum drive frequency (Hz) when it receives a 100% speed command from the OptiView Control Center. If the value received is not 50Hz or 60Hz, “INVALID” is displayed. If this is the case, then the “Motor Voltage Rating” (above) determines the maximum frequency as follows:

<u>Motor Voltage Rating</u>	<u>Output Frequency Rating</u>
2300 or 4160V	60Hz
3300V	50Hz

Toll Free Phone Number

The label for the toll free number has been changed from “York Int’l North American Toll Free Number” to “Johnson Controls North America”

Japanese Language

Japanese has been added to the selection of languages.

Variable Speed Drive Low Frequency Fault

In previous software versions, the “VSD – Low Frequency Detected” safety fault occurs when the VSD frequency is below 1Hz less than the minimum allowed running frequency after having reached the minimum frequency.

In this software version, the requirement to reach the minimum frequency before the fault can be detected, has been eliminated. Also, 20 and 25 second timers have been added to the requirement. The fault is now as follows: “After a 20 second bypass after entering “System Run”, the frequency must be below 1Hz less than the minimum frequency for 25 consecutive seconds before the fault will shutdown the chiller”.

SI0212 - SOFTWARE ENHANCEMENTS (VER 21) EFFECTIVE JUNE 2009**General**

Beginning August 2009, enhanced software will be supplied in new production YK chillers and replacement microboard kit 331-02430-601. This software is backward compatible to all previous chillers equipped with microboard 031-02430-000 or 031-02430-001. The enhancements are listed below.

The version and Program Card part number is: C.OPT.01.21-307 (031-02474-001)

Large Tonnage Chiller I/O Board

This software version supports the new LTC I/O Board (031-02895-000/001). This board communicates with the Microboard COM3 serial port (J12-2/3) using RS-485 Modbus protocol communications. This board is used for Hot Gas Bypass, Heat Recovery and Head Pressure Control options. It interfaces the Microboard to the components used for these options. A new Diagnostics Screen has been created from the Diagnostics Screen to support this board.

Optisave 2 KW Input

The Optisave 2 KW input (4-20mA) will now be wired to the LTC I/O Board (TB9-1/2) if present.

Pre-rotation Vanes Position Potentiometer

Previously, only those chillers equipped with Variable Speed Drive, Hot Gas Bypass or Variable Geometry Diffuser were equipped with a PRV position potentiometer. In the future, all new chillers will be equipped with a PRV Potentiometer, regardless of other options.

To allow this software to be backward compatible to all previous chillers not equipped with a PRV potentiometer or the options listed above, a new key labeled PRV POSITION has been added to the SETUP Screen. This allows the PRV Potentiometer input to be Enabled or Disabled.

If equipped with any of the above options, this setpoint is automatically set to ENABLED, and cannot be changed. If not equipped with any of the above options and not equipped with a PRV Potentiometer, this should be set DISABLED. If not equipped with any of the above options but factory equipped with a PRV Potentiometer, the software reads the Potentiometer input at microboard input J7-10

VSD Adaptive Capacity Control Enhancements

The following enhancements have been added:

ACC Details Screen - New Setpoints

- VSD Start Frequency – Allows the Service Technician to set the starting frequency from which the ramp-up will begin. Only shown Modbus Protocol configuration. GPIC object AV36. Programmable over the following range:
 - a. 60Hz units – 30Hz to 60Hz (default 45Hz)
 - b. 60Hz units with Quick Restart- 30Hz to 45Hz (default 45Hz)
 - c. 50Hz units – 25Hz to 50Hz (default 37.5 Hz)
 - d. 50Hz units with Quick Restart – 25Hz to 37.5Hz (default 37.5Hz)
- ACC Mapping Enable – Allows the Service Technician to set the Delta T (Leaving Chilled Liquid Temperature - Setpoint) needed to be met to enable surge mapping and speed reduction initially on startup. Only shown in Modbus Protocol configuration. Programmable over the range of 0.5°F to 4.0°F (default 1.0°F). GPIC object AV37.
- Surge Sensitivity – This key is now only shown in Modbus Protocol configuration.

ACC Surge Mapping

In Modbus Protocol configuration, ACC surge mapping is now inhibited during soft shutdowns.

SI0212 - SOFTWARE ENHANCEMENTS (VER 21) EFFECTIVE JUNE 2009 (CON'T)

ACC Current Limiting

In this software version, when in Modbus Protocol Configuration, if motor current is ≥ 101 %FLA, the VSD speed command is decreased 0.1 Hz every 3.0 seconds until the motor current < 101 %FLA. The surge map takes priority over current limiting. Thus if there is a mapped surge point in the present sector, ACC current limiting shall not be allowed to decrease the frequency below the mapped point.

In previous software versions, the initial ramp is complete when either of the following conditions occur:

- Delta T $<$ ACC Mapping Enable
- VSD Speed Command = Maximum

In this version, the initial ramp will be complete when any of the following occur:

- Delta T $<$ ACC Mapping Enable
- VSD Speed Command = Maximum
- Motor Current ≥ 100 %FLA

Stability Limit

The Stability Limit programming button was removed from the ACC Details Screen in a previous software version. The Stability Limit default and maximum values are presently set to 7000. If a new version of software were installed in a chiller with Stability Limit set below 7000, the old value would be retained. The only way to clear it would be to clear the BRAM. To prevent this from happening, this value is no longer programmable. It is now always set to 7000.

Surge During Initial Ramp

In previous software versions, if 2 surges are detected during the initial ramp (ramp towards max frequency after reaching start frequency), the command frequency is set to the max frequency regardless of motor current. This can result in motor current rising sharply and forcing vanes to have to close hard and even possibly a trip on high current or overload.

In this software version, for every 2 surges that are detected during the initial ramp, increase the command frequency (no higher than the maximum frequency) by the amount listed in the following table. After increasing the command frequency, the initial ramp surge count is reset so it can react to another 2 surges and the initial ramp shall be continued. This logic shall be in effect during the entire initial ramp and take action as many times as necessary.

Frequency Command Increase	Motor Current
1 Hz	> 90 %FLA
1.5 Hz	> 75 %FLA
2 Hz	> 60 %FLA
4 Hz	≤ 60 %FLA

VSD High Instantaneous Current Fault

In previous software versions, the “VSD-High Phase X Instantaneous Current” fault (VSD) and “VSD-High Instantaneous Current” fault (MVVSD) are a Cycling shutdown. In this version, they become a Safety shutdown if the same fault (on any phase) occurs 3 times in 90 minutes. The first 2 shutdowns with the 90 minute window will be Cycling shutdowns as it is presently. If a third occurs within 90 minutes of the first, the third will be a Safety shutdown that requires a manual restart.

SI0212 - SOFTWARE ENHANCEMENTS (VER 21) EFFECTIVE JUNE 2009 (CON'T)

The 90 minute window applies to a High Instantaneous Fault on any phase. Three faults on any phase in 90 minutes results in the 3rd fault becoming a Safety shutdown. Likewise, one fault on each of the three phases results in the 3rd fault becoming a Safety shutdown.

Refrigerant Level Control Enhancements

During the VALVE PRESET TIME and subsequent 3 minute hold period after entering System Run on startup, if the actual refrigerant level is greater than the programmed Level Setpoint for 2 seconds, the preset/hold timer is canceled and normal level control is started immediately. This only applies to the programmed Level Control Setpoint and not the ramped level setpoint and only occurs while the chiller is running.

Korean Language

Korean Language has been added to the available languages.

Oil Sump Enhancements

In previous software versions, the Oil Return Solenoid (1SOL) is opened 1 minute into System Run and remains open until System Coastdown.

In this version, to avoid an "Oil – Low Temperature Differential" condition from preventing a chiller start after running at low load conditions for extended periods, the Oil Return Solenoid (1SOL) is now cycled closed when the oil temperature gets too low on the P, Q and H9 compressor chillers, while the chiller is running.

An OIL RETURN MIN Setpoint key now appears on the Oil Sump Screen when the CHILLER STYLE/COMPRESSOR TYPE Setpoint (on the Operations Screen) is set to P, Q or H9 compressor In Service access level. This setpoint is programmable over the range of 80.0°F to 110.0°F (default 95.0°F) and controls the oil return Solenoid as follows:

- When the compressor is running and the Oil Sump Temperature < Oil Return Min Setpoint, close (de-energize) the Oil Return Solenoid by de-energizing K12 relay
- When the compressor is running and Oil Sump Temperature > Oil Return Min + 7°F, open (energize) the Oil Return Solenoid by energizing K12 relay.
- During coastdown, the solenoid operation is not changed from standard logic, it remains closed. During startup the operation is not changed from standard logic, it remains closed for 1 minute after System Run.

An OIL –SATURATED CONDENSER TEMPERATURE data box is added to the Oil Sump Screen. This displays the difference between the Oil Temperature and the Saturated Condenser temperature. This parameter is useful when analyzing oil heater operation since it is used in the control of the Oil Heater.

Variable Geometry Diffuser Operation with Hot Gas Bypass

If the VGD operation is in the HOT GAS OVERRIDE state and a Stall is detected, it will transition to the STALL REACTING State. In previous software versions, it would not react to stall in the Hot Gas Override State.

Trend Data Point Max (Y-Axis) Setup

This software version allows a greater range of the trend maximum display value for the Y-Axis.

Heat Recovery

This software supports the new Heat Recovery option. This option uses two tube bundles in the condenser. The lower bundle is the standard condenser bundle and is piped to the cooling tower water source. The upper tube bundle is used to recover heat waste heat rejection for use in a closed loop heating circuit.

On a heat recovery chiller, the chiller primary control remains the cooling load. So, the compressor capacity is still functioning according to the leaving chilled water temperature set point.

SI0212 - SOFTWARE ENHANCEMENTS (VER 21) EFFECTIVE JUNE 2009 (CON'T)

The desired hot water temperature leaving the heating bundles is obtained by regulating the heat rejection through the standard lower tube bundle (sourced by cooling tower or other water circuit). This is done by controlling the temperature of the Return Condenser Water Temperature (by tower bypass circuit to elevate the temperature of the return condenser water) or varying the condenser water flow. This control can be performed by the Optiview Control Center or an external controller. If the Optiview Control Center is used to perform this control, The Heat Recovery Control Valve is modulated to control the Leaving Heating Condenser Water Temperature to the Hot Water Setpoint. The control output to the valve is Direct Acting (when the Leaving Heating Condenser Water Temperature rises above the Hot Water Setpoint, the valve is driven more open to provide greater cooling to the standard lower tube bundle).

The heat recovery bundle is provided with a Leaving Heating Condenser Water Thermistor, Return Heating Condenser Water Thermistor and a Heating Condenser Water Flow Switch. The heat recovery circuit control is only active when the flow sensor indicates flow.

If the chiller is equipped for Heat Recovery, the feature must be ENABLED on the SETUP Screen. Otherwise, it must be DISABLED. Once enabled, the HEAT RECOVERY Screen is available from the CONDENSER Screen. All of the Heat Recovery parameters are displayed on this screen. If Head Pressure Control is also enabled, the Head Pressure parameters appear on the Heat Recovery Screen (there is no separate Head Pressure Control Screen in this configuration).

A complete explanation of this feature is contained in Service Manual 160.54-M1 Section 24.

Head Pressure Control

YK Chillers are capable of operation within a wide range of condenser water temperatures. However, a minimum condenser water temperature, as specified in the Engineering Guide, is required to maintain sufficient pressure differential (head) between the condenser and evaporator for proper oil and refrigerant management in the chiller.

Should colder condenser water temperatures be anticipated at the cooling source, a field mounted facility control means may be provided to ensure adequate head pressure exists. The preferred means would be a cooling tower bypass circuit that maintains a constant flow rate through the condenser, since this would maintain adequate tube velocity in the condenser, while regulating the return cooling water to the condenser. However, a two-way condenser water throttling valve, a variable speed cooling tower pump, or tower fan control circuit might also be employed.

The head pressure control function provides an analog output control signal from the Optiview Control Center that responds to the programmed Head Pressure (condenser pressure minus evaporator pressure) Setpoint. The output is direct acting (as the Head Pressure increases above the setpoint, the valve is driven more open to provide less tower bypass or more flow through the condenser).

If the chiller is equipped for Head Pressure Control, the feature must be ENABLED on the SETUP Screen using the Head Pressure Control Setpoint. Otherwise it must be DISABLED. Once enabled, the Head Pressure Control Screen is available from the Condenser Screen. All of the Head Pressure Control parameters are displayed on this screen. If Heat Recovery is also Enabled, the Head Pressure parameters appear on the Heat Recovery Screen (there is no separate Head Pressure Control Screen in this configuration).

A complete explanation of this feature is contained in Service Manual 160.54-M1.

Quick Start Mode

The Quick Start feature is useful in data center and process control applications where it is desirable to re-establish cooling as fast as possible after a shutdown or power failure. This feature, when enabled, allows quicker starts and restarts than normal control. It does this by reducing the time cycle for chiller restart and once running, loading the chiller as fast as possible. After the chiller is running and has met a specified setpoint or a specified period of time has elapsed, control returns to normal.

SI0212 - SOFTWARE ENHANCEMENTS (VER 21) EFFECTIVE JUNE 2009 (CON'T)

In order to use this feature, the chiller must be equipped with a Variable Speed Drive (in Modbus Protocol Configuration) or a Medium Voltage Variable Speed Drive. The low inrush current of a VSD allows more starts per hour and allows the chiller to start with a more open vane position.

Although not required, the Hot Gas Bypass option is recommended, as it will allow the chiller to startup more smoothly with less chance of surging.

Quick Start feature has two different start modes:

- Quick Restart – When a chiller shutdowns, if certain conditions are met at the completion of Coastdown (and within 30 seconds thereafter), the VSD is started immediately with no Prelube. The vanes are given a constant open pulse and after the VSD achieves its start frequency, the speed ramp rate is faster than with normal control.
- Quick Normal Start – If the conditions for a Quick Restart are not met, the next time the chiller is started, it has a prelube period just like a normal start, however the vanes will begin to open at the beginning of Prelube, instead of waiting until System Run. At the completion of Prelube, the VSD is started and after the VSD achieves its Start Frequency, the speed ramp rate is faster than with normal control.

In order to take full advantage of the Quick Start feature after a power failure, the Optiview Control Center and VSD control power (except for the Trigger Board) must be on a UPS. This prevents a reboot of both on a power failure and keep communications between them active throughout the utility power failure. This provides the fastest possible ability to start or restart after generator or utility power is restored.

This feature can only be enabled if the Motor Drive Type setpoint is set to MV VSD or VSD (and the Motor Communications Protocol Setpoint is set to MODBUS). It requires an ADMIN password to change. When logged in at ADMIN access level, a QUICK START key will appear on the SETPOINTS Screen. Pressing this key will navigate to the QUICK START Screen where the QUICK START MODE Setpoint is used to enable/disable this feature as explained in the Setpoints section below.

Once enabled, all setpoints and parameters related to this feature are displayed on the QUICK START Screen, accessible from the SETPOINTS Screen when logged in at Service access level.

A complete explanation of this feature is contained in Service Manual 160.54-M1 Section 26.

