



Operation and Maintenance

EarthWise™ Purge System with Tracer AdaptiView™ Control for Water-Cooled CenTraVac™ Chillers



X39641072040

⚠ SAFETY WARNING

Only qualified personnel should install and service the equipment. The installation, starting up, and servicing of heating, ventilating, and air-conditioning equipment can be hazardous and requires specific knowledge and training. Improperly installed, adjusted or altered equipment by an unqualified person could result in death or serious injury. When working on the equipment, observe all precautions in the literature and on the tags, stickers, and labels that are attached to the equipment.



Introduction

Read this manual thoroughly before operating or servicing this unit.

Warnings, Cautions, and Notices

Safety advisories appear throughout this manual as required. Your personal safety and the proper operation of this machine depend upon the strict observance of these precautions.

The three types of advisories are defined as follows:

⚠ WARNING Indicates a potentially hazardous situation which, if not avoided, could result in death or serious injury.

⚠ CAUTION Indicates a potentially hazardous situation which, if not avoided, could result in minor or moderate injury. It could also be used to alert against unsafe practices.

NOTICE Indicates a situation that could result in equipment or property-damage only accidents.

Important Environmental Concerns

Scientific research has shown that certain man-made chemicals can affect the earth's naturally occurring stratospheric ozone layer when released to the atmosphere. In particular, several of the identified chemicals that may affect the ozone layer are refrigerants that contain Chlorine, Fluorine and Carbon (CFCs) and those containing Hydrogen, Chlorine, Fluorine and Carbon (HCFCs). Not all refrigerants containing these compounds have the same potential impact to the environment. Trane advocates the responsible handling of all refrigerants-including industry replacements for CFCs such as HCFCs and HFCs.

Important Responsible Refrigerant Practices

Trane believes that responsible refrigerant practices are important to the environment, our customers, and the air conditioning industry. All technicians who handle refrigerants must be certified. The Federal Clean Air Act (Section 608) sets forth the requirements for handling, reclaiming, recovering and recycling of certain refrigerants and the equipment that is used in these service procedures. In addition, some states or municipalities may have additional requirements that must also be adhered to for responsible management of refrigerants. Know the applicable laws and follow them.

⚠ WARNING

Proper Field Wiring and Grounding Required!

Failure to follow code could result in death or serious injury. All field wiring **MUST** be performed by qualified personnel. Improperly installed and grounded field wiring poses **FIRE** and **ELECTROCUTION** hazards. To avoid these hazards, you **MUST** follow requirements for field wiring installation and grounding as described in NEC and your local/state electrical codes.

⚠ WARNING

Personal Protective Equipment (PPE) Required!

Installing/servicing this unit could result in exposure to electrical, mechanical and chemical hazards.

- Before installing/servicing this unit, technicians **MUST** put on all PPE required for the work being undertaken (Examples; cut resistant gloves/sleeves, butyl gloves, safety glasses, hard hat/bump cap, fall protection, electrical PPE and arc flash clothing). **ALWAYS** refer to appropriate Material Safety Data Sheets (MSDS)/Safety Data Sheets (SDS) and OSHA guidelines for proper PPE.
- When working with or around hazardous chemicals, **ALWAYS** refer to the appropriate MSDS/SDS and OSHA/GHS (Global Harmonized System of Classification and Labelling of Chemicals) guidelines for information on allowable personal exposure levels, proper respiratory protection and handling instructions.
- If there is a risk of energized electrical contact, arc, or flash, technicians **MUST** put on all PPE in accordance with OSHA, NFPA 70E, or other country-specific requirements for arc flash protection, **PRIOR** to servicing the unit. **NEVER PERFORM ANY SWITCHING, DISCONNECTING, OR VOLTAGE TESTING WITHOUT PROPER ELECTRICAL PPE AND ARC FLASH CLOTHING. ENSURE ELECTRICAL METERS AND EQUIPMENT ARE PROPERLY RATED FOR INTENDED VOLTAGE.**

Failure to follow instructions could result in death or serious injury.

⚠ WARNING**Refrigerant under Positive Pressure!**

Failure to follow instructions below could result in an explosion which could result in death or serious injury or equipment damage. System contains oil and refrigerant and may be under positive pressure. Recover refrigerant to relieve pressure before opening the system. See unit nameplate for refrigerant type. Do not use non-approved refrigerants, refrigerant substitutes, or refrigerant additives.

Copyright

This document and the information in it are the property of Trane, and may not be used or reproduced in whole or in part without written permission. Trane reserves the right to revise this publication at any time, and to make changes to its content without obligation to notify any person of such revision or change.

Trademarks

All trademarks referenced in this document are the trademarks of their respective owners.

Revision History

PRGD-SVX01D-EN (14 May 2015)

- Updates to warning/caution/notice format
- Labels added for clarification:
 - kPaA = kPa Absolute
 - kPaD = kPa Differential
 - kPaG = kPa Gauge
- Update to UL-required pressure-relief device fuse specifications in [“Purge System Overview,”](#) p. 5



Table of Contents

Introduction	2	Alarms	22
Warnings, Cautions, and Notices	2	Maintenance	23
Important Environmental Concerns	2	Weekly Maintenance	23
Important Responsible Refrigerant Practices	2	Semi-Annual Maintenance	23
Table of Contents	4	Annual Maintenance	23
Purge System Overview	5	Replacing the Filter-Drier Assembly	23
Introduction	5	Inspecting the Moisture Indicator	24
Reference Sources	5	Maintaining the Moisture-Indicating Sight Glass	24
How a Purge System Works	5	Removing Air After Servicing the Chiller	25
Refrigeration Circuit Subsystem	5	Troubleshooting	26
Purge Tank Subsystem	7	Diagnostics	26
Pump-out Subsystem	8	Carbon Regeneration Temperature Diagnostic Procedure	28
Carbon Tank and Regeneration Subsystem	8	Purge Refrigeration Circuit Diagnostic Procedures	28
Tracer AdaptiView Control Subsystem	8	Taking Surface Temperature Measurements	28
Sequence of Operations	10	Determining the Refrigerant Charge Level	29
Purge Operating Modes	10	Determining Proper Expansion Valve Operation	29
Adaptive Mode	10	Determining Correct Vapor Pick-up and Liquid Return Line Connection Locations	29
Adaptive Mode Process—Chiller Compressor On	10	Using the Service Functions	29
Adaptive Mode Procedure—Chiller Compressor Off	12	Purge Exhaust Circuit Test	30
Typical Purge Refrigeration Circuit Operating Cycle	12	Exhaust Circuit Pressure Check	30
Air Removal	15	Exhaust Circuit Vacuum Check	30
Pump-out Operating Sequence	16	Specifications	31
Non-Condensable Pump-out Algorithm	16	EarthWise Purge System Model Number	32
Non-condensable Pump-out cycle	17	Schematic Wiring Diagram	33
Establishing a Daily Pump-Out Limit	18	EarthWise Purge System with Tracer AdaptiView Controls	33
Carbon Tank and Regeneration Subsystem	18		
Carbon Regeneration Algorithm	18		
Carbon Tank Regeneration Sequence	19		
Operator Interface	21		
Reports	21		
Log Sheet	21		
Purge Operating Modes	21		
Settings	22		
Purge Settings	22		
Manual Control Settings	22		



Purge System Overview

This guide describes the operation and maintenance of a Trane EarthWise purge system with Tracer AdaptiView controls. Tracer AdaptiView controls include the Tracer™ UC800 controller and the Tracer AdaptiView display.

Introduction

Centrifugal chillers that use low-pressure refrigerants, such as R-123, operate with areas of the chiller at less than atmospheric pressure. Non-condensables in the air, such as water and nitrogen vapor, may leak into these low-pressure areas and accumulate in the condenser. If these non-condensables are not removed, the condenser loses its ability to condense refrigerant efficiently, and the pressure of the condenser increases. Increased condenser pressure lowers the chillers efficiency and capacity.

A purge system is required on low-pressure centrifugal chillers. It is a device that is externally mounted on the chiller. Its purpose is to remove non-condensable materials that have leaked into the machine.

Note: For convenience, the term “air” is often used in this document, although any other non-condensable materials that may exist in the chiller are also removed by the purge system.

Reference Sources

The following reference documents may be helpful resources for EarthWise purge system operation and maintenance:

- *Installation, Operation, and Maintenance Guide: CVHE, CVHF, CVHG Water-Cooled CenTraVac™ Chillers with Tracer AdaptiView™ Control* (CVHE-SVX02*-EN)
- *Installation, Operation, and Maintenance Guide: CDHF and CDHG Water-Cooled CenTraVac™ Chillers with Tracer AdaptiView™ Control* (CDHF-SVX01*-EN)
- *Diagnostics Manual: Diagnostic Descriptions, Troubleshooting Tables, and Control Component Overview for Water-Cooled CenTraVac™ Chillers with Tracer AdaptiView™ Control* (CTV-SVD03*-EN)
- *Programming Guide: Tracer™ TU Service Tool for Water-Cooled CenTraVac™ Chillers with Tracer AdaptiView™ Control* (CTV-SVP02*-EN)
- *Operations Guide: Tracer AdaptiView™ Display for Water-Cooled CenTraVac™ Chillers* (CTV-SVU01*-EN)
- *Getting Started Guide: Tracer™ TU Service Tool* (TTU-SVN01*-EN)

How a Purge System Works

From a functional standpoint, the purge system can be divided into subsystems of components. This section identifies and describes the function of these subsystems.

The following list identifies these subsystems and their components; [Figure 1, p. 6](#), and [Figure 2, p. 7](#), illustrate them:

- Refrigeration circuit subsystem ([p. 5](#))
 - Purge tank
 - Purge evaporator coil (inside purge tank)
 - 1/4 hp air-cooled condensing unit (compressor, fan, condensing coil)
 - Automatic expansion valve
 - Chiller refrigerant supply line
 - Chiller refrigerant return line (includes filter-drier and moisture-indicating sight glass)
- Purge tank subsystem ([p. 7](#))
 - Purge tank
 - Purge evaporator coil (inside purge tank)
 - Pressure-relief device (fusible plug)
 - Liquid level sensor (float switch)
 - Supply and return lines to the chiller condenser
- Pump-out subsystem ([p. 8](#))
 - Pump-out compressor
 - Pump-out solenoid valve
- Carbon tank and regeneration subsystem ([p. 8](#))
 - Carbon tank
 - Carbon tank heater
 - Regeneration solenoid valve
 - Exhaust solenoid valve
 - Pressure-relief valve
 - Temperature sensor
- Purge control subsystem ([p. 8](#))
 - Tracer UC800 controller
 - Tracer AdaptiView display

Refrigeration Circuit Subsystem

The purge evaporator of the refrigeration circuit is located in the purge tank. The purge tank is connected to the chiller condenser by supply and return lines through which chiller refrigerant can freely flow.

The purge evaporator coil presents a cold condensing surface to the chiller refrigerant entering the purge tank. When the purge refrigeration system is running, refrigerant from the chiller condenser is attracted to the cold surface of the purge evaporator. When the gaseous refrigerant contacts the surface of the purge evaporator coil, it condenses into a liquid, leaving a partial vacuum behind. More refrigerant vapor from the chiller condenser migrates to the purge tank to fill the vacuum.

Purge System Overview

The liquid refrigerant that has condensed in the purge tank returns to the chiller condenser through the liquid return line. The return line includes a filter-drier and a moisture-indicating sight glass.

The condensing unit is air-cooled, and is operable whether the chiller is running or not. No additional cooling source is required.

Figure 1. Components of a Trane EarthWise purge system (front view)

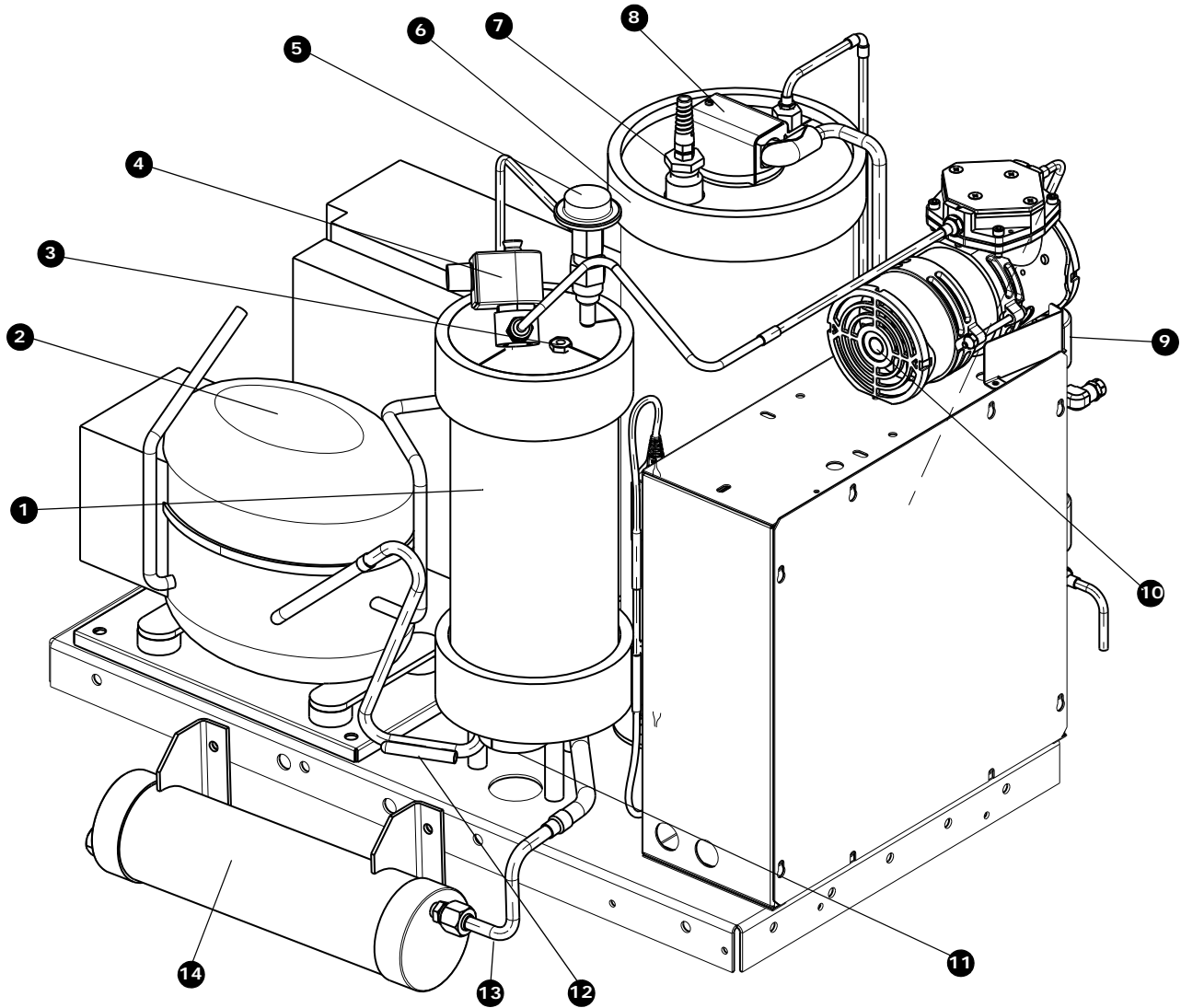

1. Purge tank
2. Condensing unit (includes compressor, condenser coil, and fan)
3. Pressure-relief device (fusible plug)
4. Pump-out solenoid valve
5. Automatic expansion valve
6. Carbon tank
7. Carbon tank temperature sensor
8. Carbon tank heater
9. Exhaust solenoid valve
10. Pump-out compressor
11. Float switch
12. Compressor suction temperature sensor
13. Chiller refrigerant return line
14. Filter-drier canister

Figure 2. Components of a Trane EarthWise purge system (back view)

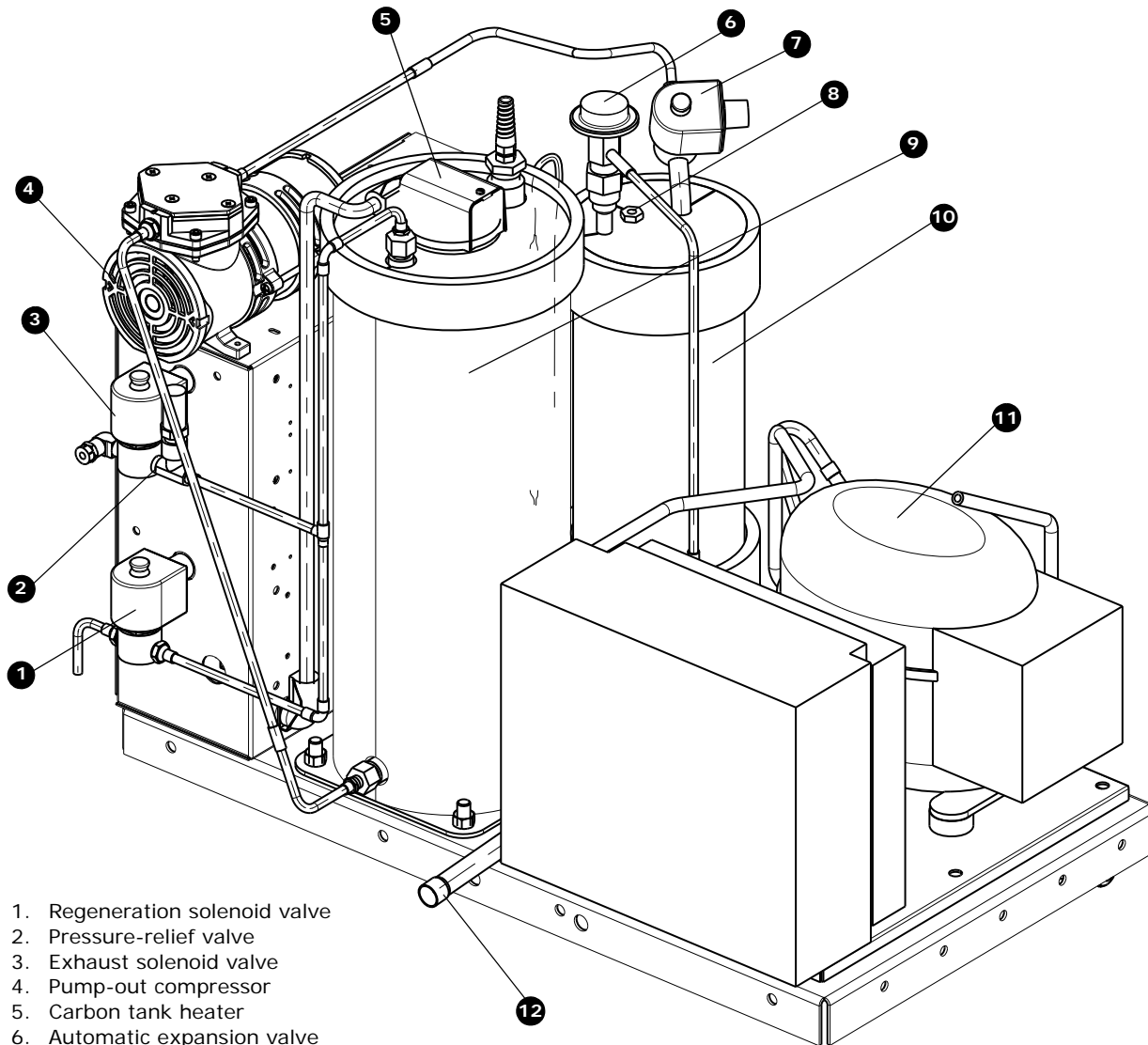

1. Regeneration solenoid valve
2. Pressure-relief valve
3. Exhaust solenoid valve
4. Pump-out compressor
5. Carbon tank heater
6. Automatic expansion valve
7. Pump-out solenoid valve
8. Pressure-relief device (fusible plug)
9. Carbon tank
10. Purge tank
11. Condensing unit
12. Chiller refrigerant supply line

Purge Tank Subsystem

Any non-condensables that have accumulated from the refrigerant vapor are left behind to collect in the purge tank. As the quantity of non-condensables increases, the heat transfer efficiency of the purge evaporator coil is reduced, causing the purge compressor suction temperature to decrease.

A float switch, mounted in the bottom of the purge tank, indicates if there is excessive accumulation of liquid refrigerant in the tank. A liquid level sensor, which resides

in the purge control panel, monitors the status of the float switch.

If the normally closed float switch is open for more than 20 minutes, the purge controls will turn off the refrigeration system and generate a non-latching diagnostic—Purge Liquid Level Too High Warning. If the float switch has re-closed after 20 minutes, the purge controls will restart the refrigeration system.

If the float switch remains open for more than 20 minutes, or if the float switch/liquid level restart cycle has occurred more than four times in four hours, a latching diagnostic—Purge Liquid Level Too High Continuously—will be



Purge System Overview

generated. The purge system will not restart until it is reset.

If a Purge Liquid Level Too High Continuously diagnostic occurs, check the purge lines for any type of restriction (trapped liquid, closed valves, etc.) and ensure that the filter-drier on the liquid return line is in good condition.

A UL-required pressure-relief device (fusible plug), which protects against over-pressurization of the purge tank, is mounted on the purge tank. The plug material will fuse at 210°F (98.9°C), which equates to approximately 98 psig (675.7 kPaG) for refrigerant R-123.

Pump-out Subsystem

When the purge control subsystem detects the presence of non-condensables in the purge tank, the pump-out solenoid and exhaust solenoid valves open, and the pump-out compressor turns on. The valves and the compressor cycle on and off as needed to achieve an efficient and fast removal of non-condensables.

Note: A High Vacuum Pump option is available for applications that require purge operation at low condensing temperatures and pressures. This option provides a two-stage pump-out compressor. The High Vacuum Pump option allows the purge system to operate to saturation temperatures as low as 34°F (2.8°C). Typical applications that may require the High Vacuum Pump option include free-cooling installations, series chiller installations, ice systems having brine flowing through idle chillers, chillers installed outdoors or in unconditioned spaces, or any application that may cause very low condenser water temperatures.

Carbon Tank and Regeneration Subsystem

The discharge from the pump-out compressor is piped through the carbon tank. The special carbon in the tank effectively scrubs and collects refrigerant molecules from the non-condensable gas before the gas passes through the exhaust solenoid valve to the chiller vent line.

A 175 W resistive heater is mounted inside the carbon tank and is used to periodically “regenerate” the carbon bed and drive any collected refrigerant vapor back into the chiller. A UL-required pressure-relief valve, rated at 150 psi (1034.2 kPa), is mounted on the line leaving the carbon tank. The valve protects against over-pressurization of the carbon tank.

A temperature sensor is installed through the top of the carbon tank shell so that the controls can monitor the carbon bed temperature. The temperature sensor controls the regeneration cycle and protect against overheating. If the limit temperature is reached, the system shuts down and a Purge Carbon Regen Temperature Limit Exceeded diagnostic is generated.

Tracer AdaptiView Control Subsystem

The main elements of the Tracer AdaptiView control subsystem are described in this section.

Tracer UC800 controller

Control of the EarthWise purge system is provided by the Tracer UC800 controller. The controller is mounted in the chiller control panel and is used to interface with the purge system as well as the chiller.

Tracer AdaptiView display

The operator interface for control of the chiller, including the purge system, is the Tracer AdaptiView display. For detailed information on the display, refer to *Operations Guide: Tracer AdaptiView™ Display for Water-Cooled CenTraVac™ Chillers* (CTV-SVU01*-EN).

Much of the purge setup, operation, and troubleshooting can be accomplished using the Tracer AdaptiView display. However, more advanced functions require the use of the laptop-based Tracer TU service tool. For more information, refer to *Getting Started Guide: Tracer™ TU Service Tool* (TTU-SVN01*-EN).

Sensors

The following sensors are used to enable control communication between the Tracer UC800 controller and the EarthWise purge system. The sensors use low-level intelligence devices (LLIDs) to communicate with the Tracer UC800 controller.

Compressor suction temperature sensor. This sensor is mounted on the purge condensing unit suction line. The controller uses the value of this temperature sensor to decide whether or not to purge non-condensables from the purge tank. When the temperature drops to a specified point, the controller activates the pump-out cycle to remove the accumulated non-condensables from the purge tank. When enough non-condensables have been removed and the purge compressor suction temperature increases in response, the controller terminates the pump-out cycle.

Saturated condenser temperature sensor. This sensor is mounted on the chiller. If the chiller is running, the controller uses the value of this temperature sensor to adjust the purge pump-out initiate/terminate setpoints. It may be used to prohibit pump-out, if system conditions are too cool.

Saturated evaporator temperature sensor. This sensor is mounted on the chiller. If the chiller is Off, the controller uses the value of this temperature sensor to adjust the purge pump-out initiate/terminate setpoints. It may be used to prohibit pump-out, if system conditions are too cool.

Carbon tank temperature sensor. This sensor is mounted in the carbon tank of the purge system. It provides feedback to the carbon regeneration algorithm.

The sensor and the controller function much the same as a thermostat to control the carbon tank heater.

Liquid level sensor. This sensor resides in the purge control panel. It monitors the status of the normally closed float switch, which is mounted in the bottom of the purge tank. If an adequate amount of liquid fails to drain from the purge tank, the float switch and sensor detect the condition and prevent further purge operation.

Condensing unit LLID. This LLID resides in the purge control panel. It uses a high-capacity relay to control the operation of the purge condensing unit.

Quad relay LLID. This LLID resides in the purge control panel. It has four relay outputs that are used to control the pump-out compressor, the carbon tank heater, the regeneration solenoid valve, and an alarm output.

Dual triac LLID. This LLID resides in the purge control panel. It has two triac-type outputs that are used to control the pump-out solenoid valve and the exhaust solenoid valve. The purge system draws its control power from the power supplies of the chiller control panel.

Machine bus

The Machine bus is the communication link between the components of the Tracer UC800 controller. The Machine bus protocol is based on RS485 signal technology and communicates at 19.2 kbaud.

The Tracer UC800 controller manages the Machine bus. The UC800 has the task of re-establishing the communication link if it has been degraded. If a parameter is reported out of range by a LLID, the UC800 processes this information and generates a diagnostic. Individual LLIDs are not responsible for any diagnostic functions.



Sequence of Operations

A Tracer UC800 controller that is configured to control a purge system controls the uses the operational sequences described in this section.

Purge Operating Modes

Purge operating mode options are as follows:

Stop. The purge condensing unit does not run in this mode.

On. The purge condensing unit runs continuously in this mode, regardless of the chillers operational status.

Auto. The purge condensing unit runs in this mode, if the main compressor of the chiller is operating.

Adaptive. The purge condensing unit operation depends on past purge activity.

Adaptive Mode

The objectives of operating the unit in the adaptive mode are to:

- Enable purge system operation
- Enable the refrigeration circuit to effectively accumulate non-condensables whether or not the chiller is running
- Provide information to an operator regarding whether leakage is on the high-pressure or low-pressure side of the chiller
- Decrease energy usage by running the purge refrigeration circuit only when needed to remove non-condensables, rather than running it continuously

The adaptive mode requires historical operating data so that the controller can make optimal decisions regarding how to run the purge refrigeration circuit in the future. On initial start-up of a chiller that is in adaptive mode, the purge refrigeration circuit runs continuously for 168 hours (7 days). The chiller compressor may or may not be running during this period.

Following the initial data collection period, the adaptive mode customizes the purge refrigeration circuit operation during two distinct chiller operating conditions:

- Chiller compressor On
- Chiller compressor Off

Adaptive Mode Process—Chiller Compressor On

Figure 3, p. 11, illustrates the process described in this subsection.

When the chiller compressor starts, the purge refrigeration circuit starts. The purge refrigeration circuit continues to run until 60 consecutive minutes of running occur without any pump-out of non-condensables. The Pumpout Time is

the greater of the following two values that the controller has been tracking:

- The pump-out time with the chiller On, over the last 24 hours
- The average daily pump-out time with the chiller On, over the last 7 days

Figure 3. Adaptive chiller ON flow chart

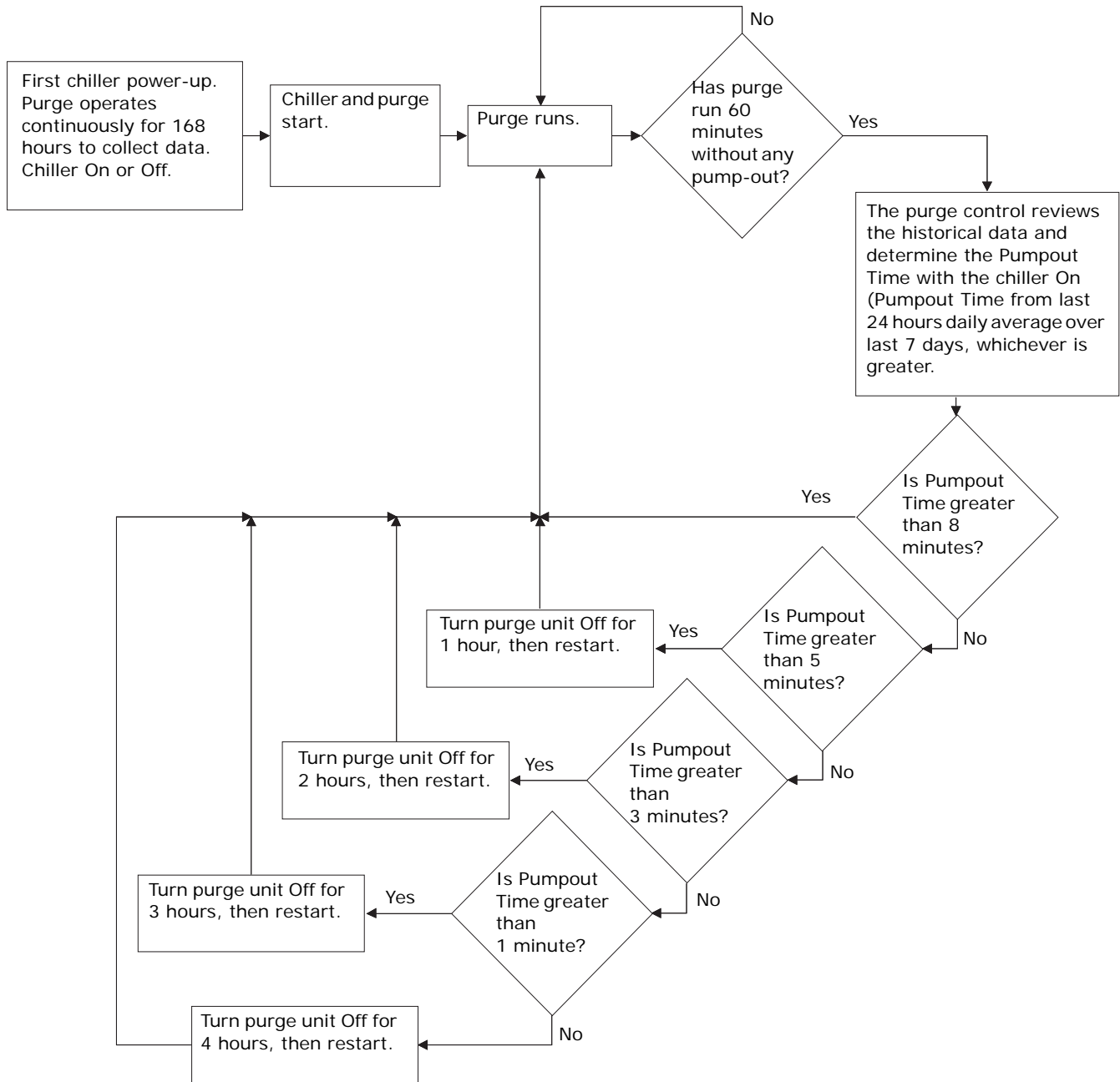

The purge then shuts down for a corresponding period of time, as shown in the following table:

Pumpout Time with chiller On (over the last 24 hours or daily average over the last 7 days, whichever is greater)	Purge Off cycle duration
Pumpout Time \leq 1 minute	4 hours
1 minute < Pumpout Time \leq 3 minutes	3 hours
3 minutes < Pumpout Time \leq 5 minutes	2 hours
5 minute < Pumpout Time \leq 8 minutes	1 hour
Pumpout Time > 8 minutes	No Off cycle



Sequence of Operations

During the purge refrigeration circuit Off cycle, the time remaining is displayed as Time Until Next Purge Run in the Log Sheet that you can view from the Tracer AdaptiView display (refer to “Log Sheet,” p. 21).

If the compressor is turned Off during the purge refrigeration circuit Off cycle, the purge transfers to Adaptive Mode Procedure—Chiller Compressor Off. Figure 4, p. 13 illustrates this process.

Adaptive Mode Procedure—Chiller Compressor Off

Refer to Figure 4, p. 13 for an illustration of the process described in this subsection.

If the chiller compressor is turned Off, the purge refrigeration circuit Off cycle is determined by the purge control. The purge Off-cycle duration is determined by the pump-out time, which is the greater of the following two values:

- Daily Pumpout—24 Hours (the pump-out time over the last 24 hours whether the chiller is On or Off)
- Average Daily Pumpout—7 Days (the pump-out time with the chiller On over the last 7 days)

Note: These two values can be seen on the Tracer AdaptiView display.

The purge will be shut down for a corresponding period of time, as shown in the following table:

The pump-out time with chiller On or Off (over the last 24 hrs or daily average over the last 7 days, whichever is greater)	Purge Off cycle duration
Pump-out time ≤ 1 minute	3 days
1 minute < pump-out time ≤ 3 minutes	2 days
3 minutes < pump-out time ≤ 5 minutes	1 day
Pump-out time > 5 minutes	6 hours

During the purge refrigeration circuit Off cycle, the time remaining is displayed as the Time Until Next Purge Run in the purge report of the Tracer AdaptiView display.

If the controls determine it is necessary to run the purge while the chiller compressor is Off, the purge will be started and run until 60 consecutive minutes have passed without any pump-out of non-condensables.

If the chiller compressor starts before the purge Off cycle has elapsed, the purge starts and transfers to Adaptive Mode Procedure—Chiller Compressor On. Figure 3, p. 11, illustrates this process.

Typical Purge Refrigeration Circuit Operating Cycle

At typical operating temperatures of 70°F (21.1°C) ambient and 100°F (37.8°C) condensing, the purge refrigeration cycle should have the temperatures shown in Figure 5 for locations 1-5.

Note: To troubleshoot the system by taking these temperatures, refer to “Taking Surface Temperature Measurements,” p. 28.

Figure 4. Adaptive chiller OFF flow chart

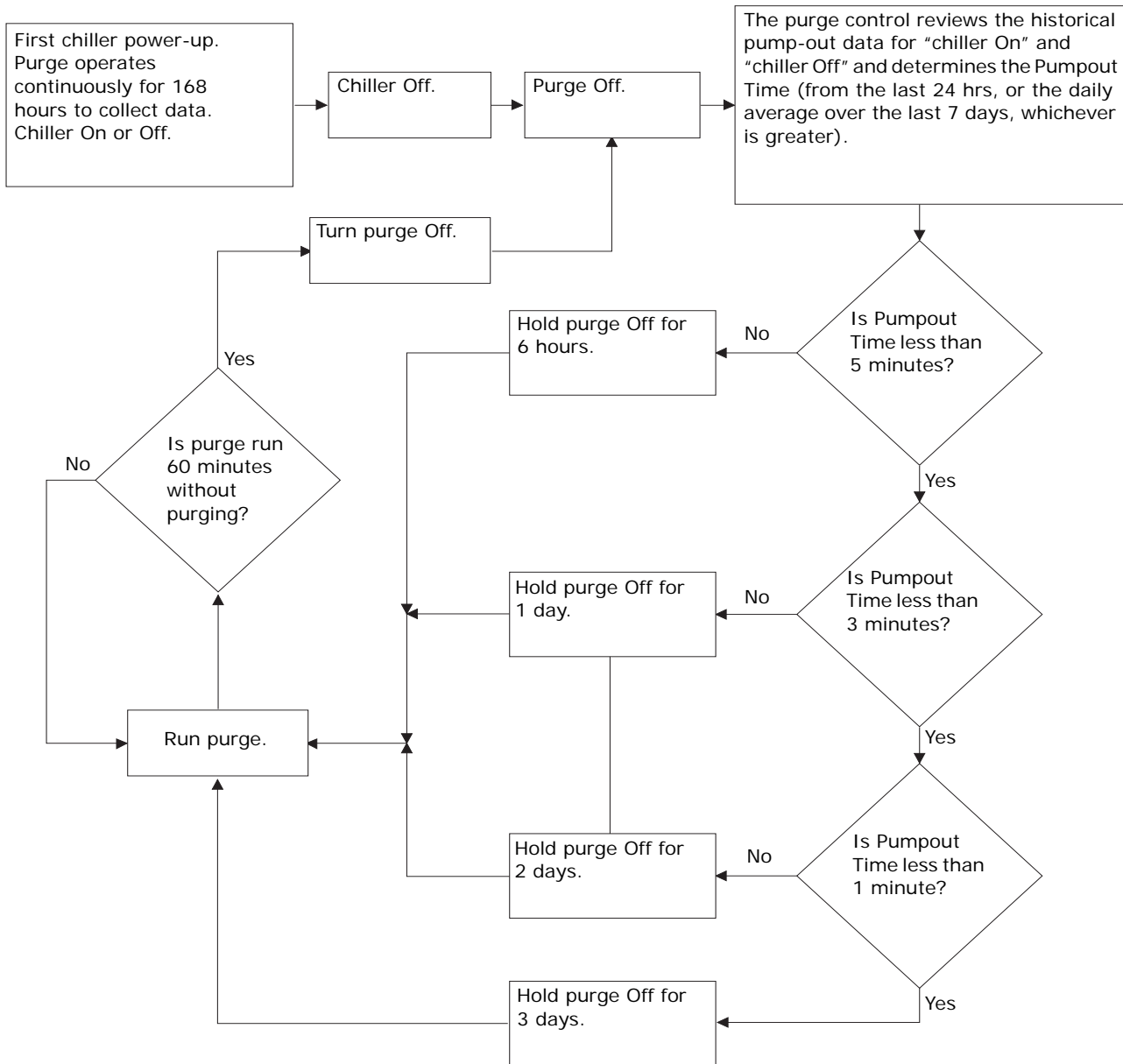
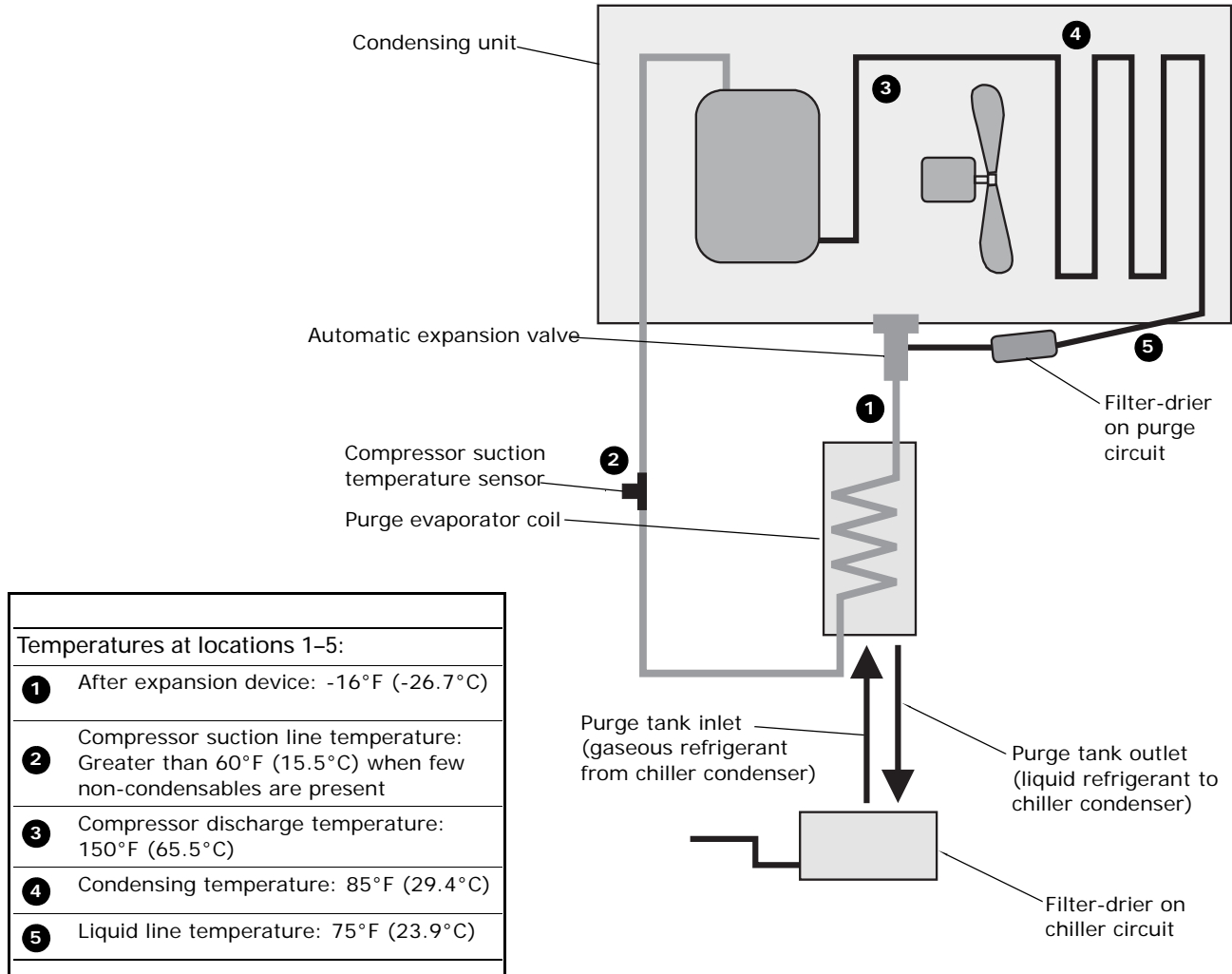

Figure 5. Purge refrigeration circuit showing temperatures at various locations in operating cycle



The purge condensing-unit compressor suction temperature (location 2 in Figure 5) varies with the amount of non-condensables collected in the purge tank. If the amount of non-condensables collected in the purge tank limits the available condensing surface in the tank, the condensing-unit compressor suction temperature begins to fall.

The purge controller initiates a pump-out cycle when the suction temperature reaches the pump-out initiate value that is calculated within the purge control. During the pump-out cycle, the small pump-out compressor pulls any non-condensables from the purge tank and discharges them through the carbon tank. As the non-condensables are removed from the purge tank, the condensing-unit compressor suction temperature increases. The purge controller monitors the compressor suction temperature and cycles or stops the pump-out, depending on the temperature that is present.

The 1/4 hp air-cooled condensing unit of the refrigeration system operates effectively when it is in the operating range shown in Figure 6.

Figure 6. EarthWise purge operating limits

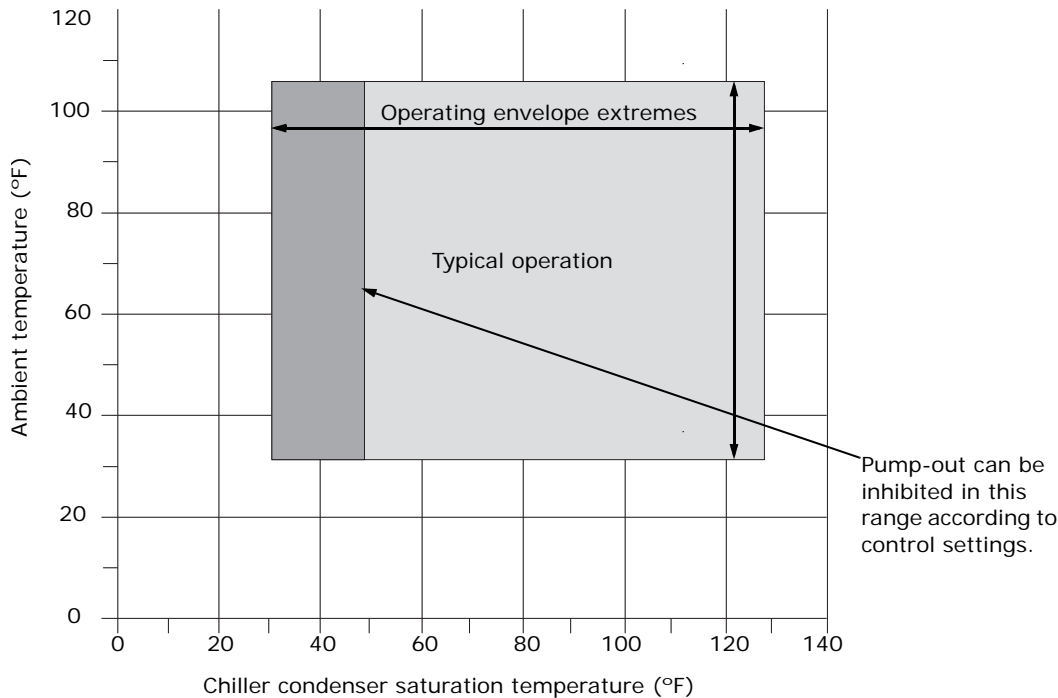

Air Removal

If no air is in the purge tank, the refrigerant returning to the purge condensing unit compressor suction has a high *superheat* (heat added past the point of evaporation), because of the heat removed from the condensing chiller refrigerant vapor in the purge tank. As air accumulates in the purge tank, it displaces the chiller refrigerant vapor and decreases the amount of coil surface that is exposed to the vapor. Less heat is removed from the vapor, and the available superheat at the purge condensing unit compressor suction consequently falls. When the purge refrigerant compressor suction temperature falls far enough to reach the pump-out initiate value, the purge control activates the solenoids and the pump-out compressor to remove the accumulated air. [Figure 7, p. 16](#), illustrates this process.

As air is removed from the purge tank, the inside coil is once again exposed to chiller refrigerant vapor. As more chiller refrigerant vapor condenses on the coil, more heat is removed from the vapor, and the purge refrigerant compressor suction temperature rises. The purge control cycles or stops the pump-out process in response to the compressor suction temperature.

Figure 7. Air removal cycle

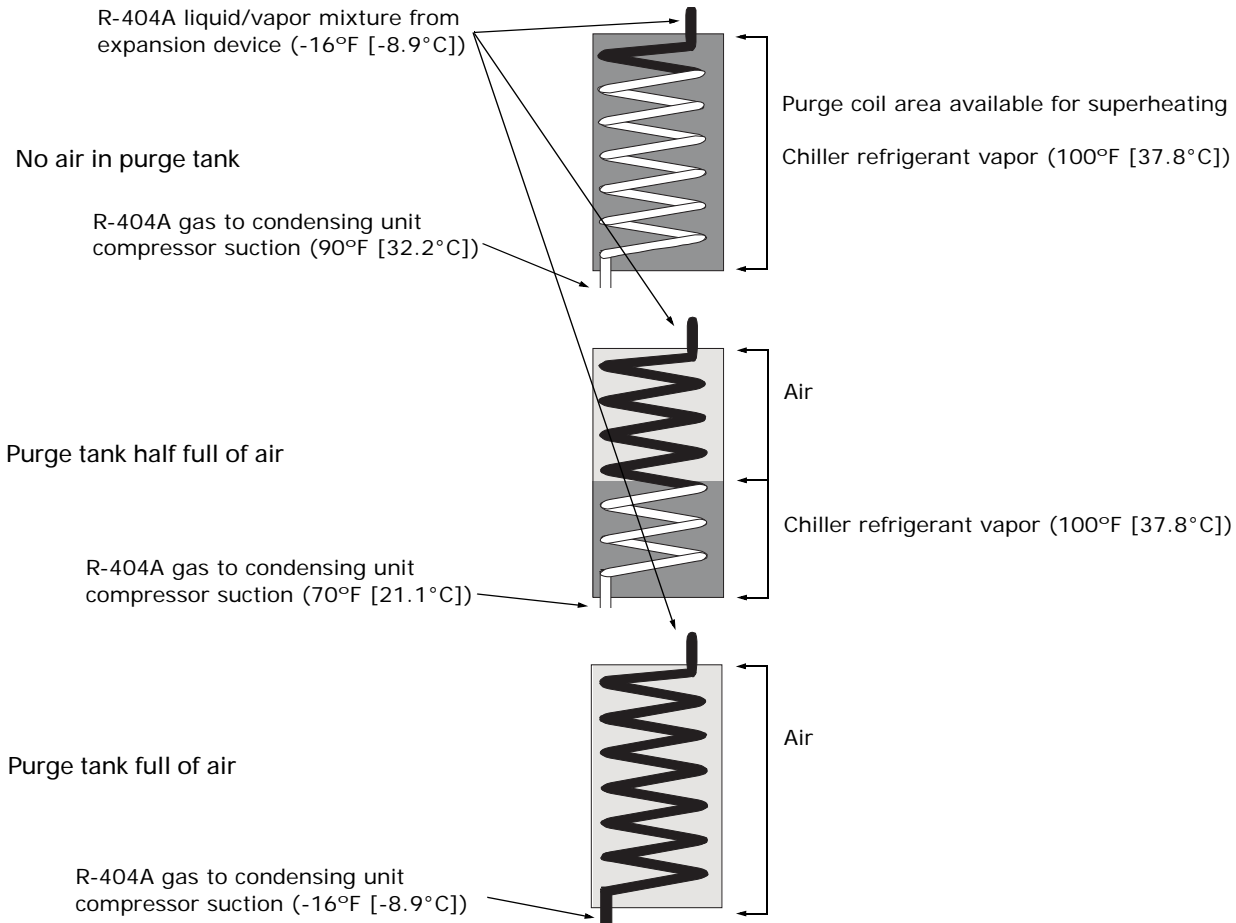

Pump-out Operating Sequence

As the purge control system detects the presence of non-condensables in the purge tank, it initiates a pump-out cycle. The pump-out solenoid valve, the exhaust solenoid valve, and the pump-out compressor cycle On and Off as needed to remove the non-condensables.

Non-Condensable Pump-out Algorithm

The controller uses the non-condensable pump-out algorithm to determine when to initiate, control, and terminate a pump-out cycle to remove air from the purge tank. The purge refrigerant compressor suction temperature sensor serves as the feedback to this control algorithm. The compressor suction temperature pump-out initiate and pump-out terminate values are calculated by the purge control and are a function of the purge liquid temperature.

The refrigerant used in the purge refrigeration circuit, R-404A, is metered into the purge tank coil by a constant-pressure regulating expansion valve. The valve automatically controls the purge suction pressure at a constant value of 34 psia (234.4 kPa). Therefore,

refrigerant is metered into the coil as a two-phase refrigerant mixture at a constant saturation temperature of approximately -16°F (-8.9°C).

The cold coil creates a low vapor pressure near its outside surface, which draws refrigerant from the chiller condenser into the purge tank and to the coil surface. When the refrigerant gets close enough to the coil surface, it condenses into a liquid. Since liquid refrigerant requires less volume than it does in a gaseous form, additional refrigerant enters the purge tank to fill the void and, in turn, condenses. This mechanism is known as a *thermal siphon*.

As the chiller refrigerant condenses, heat is transferred into the purge coil through the latent heat of condensation. The compressor suction temperature sensor monitors this heat transfer.

Air and other gases carried with the chiller refrigerant vapor do not condense on the coil. Instead, they accumulate in the purge tank, effectively acting to insulate and inhibit the flow of refrigerant to the cold coil surface. The thermal siphon rate is reduced and, consequently, so is the amount of heat transfer. A corresponding reduction occurs in the temperature of the purge refrigerant exiting

the coil. The compressor suction temperature sensor monitors this temperature.

When sufficient non-condensables have accumulated in the purge tank to decrease the compressor suction temperature below the pump-out initiate value, a pump-out cycle begins. The cycle is terminated when the compressor suction temperature sensor increases above the pump-out terminate value. The calculations for the pump-out values are:

Pump-out initiate (°F) = Purge liquid temperature (°F) – 50°F (10.0°C) or 0°F (-17.8°C) (whichever is higher)

Pump-out terminate (°F) = Purge liquid temperature (°F) – 40°F (4.4°C) or 5°F (-15.0°C) (whichever is higher)

For factory installed purges or those retrofit purges that communicate with the chiller control system, the purge liquid temperature value comes from the chiller's saturated condenser temperature sensor when the chiller is running, or the chiller's saturated evaporator temperature sensor when the chiller is off.

For a field installed retrofit purge that does not communicate with the chiller control system, a purge liquid temperature sensor is mounted on the purge liquid drain line and the resulting temperature from this sensor is used in the above equations.

Non-condensable Pump-out cycle

A non-condensable pump-out cycle may be initiated as described below only if the following two conditions are met:

- A carbon regeneration cycle is NOT in process, and
- The refrigeration circuit is on.

Figure 8. Non-condensable pump-out cycle, large quantity of air

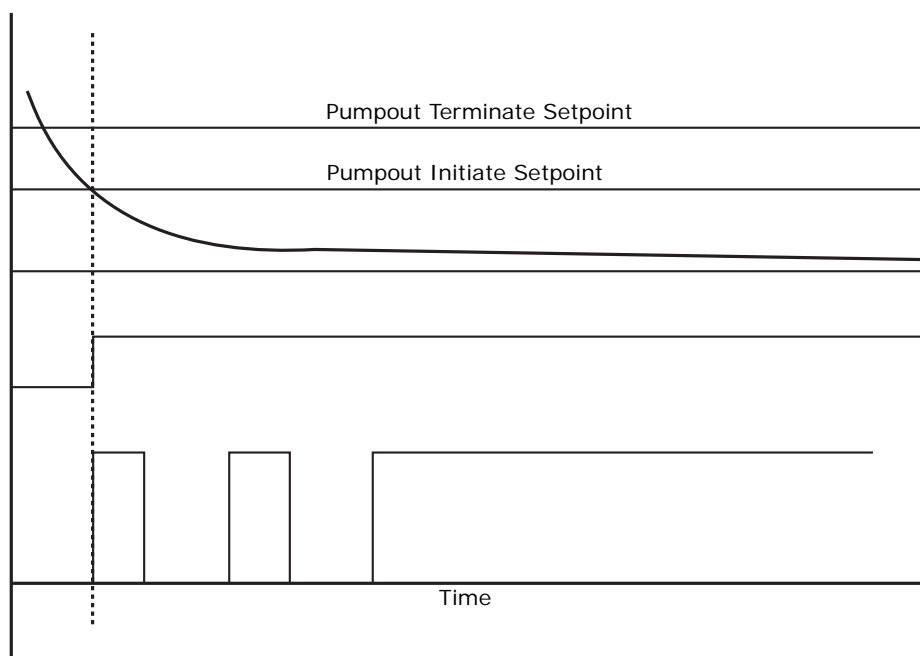

If at any time, except as described above, the purge refrigerant compressor suction temperature drops below the pump-out initiate value, the following sequence is initiated by the controls.

The controller starts the pump-out compressor and opens the exhaust solenoid valve. After 5 seconds, the pump-out solenoid valve opens and pulses at a rate of 20 seconds On and 20 seconds Off. If, after two cycles, the purge refrigerant compressor suction temperature has not exceeded the pump-out terminate value, the pump-out solenoid valve stays continuously open. If the pump-out compressor runs for more than 10 consecutive minutes, the controller recalculates the pump-out initiate and pump-out terminate values as described.

The purge controls continue to operate the pump-out solenoid valve and calculate values as described above until the purge refrigerant compressor suction temperature rises above the pump-out terminate value. At this point, the controller will close the pump-out solenoid valve and turn off the pump-out compressor and exhaust solenoid valve.

Typical pump-out cycles are shown in [Figure 8](#) and [Figure 9](#), p. 18.

Note: For purge systems equipped with standard pump-out compressors, operation at low chiller condenser saturation temperatures may result in a system vacuum greater than the pump-out compressor can overcome. If the chiller experiences low condensing temperatures, then the Tracer UC800 controller can be programmed to inhibit the operation of the purge pump-out compressor.

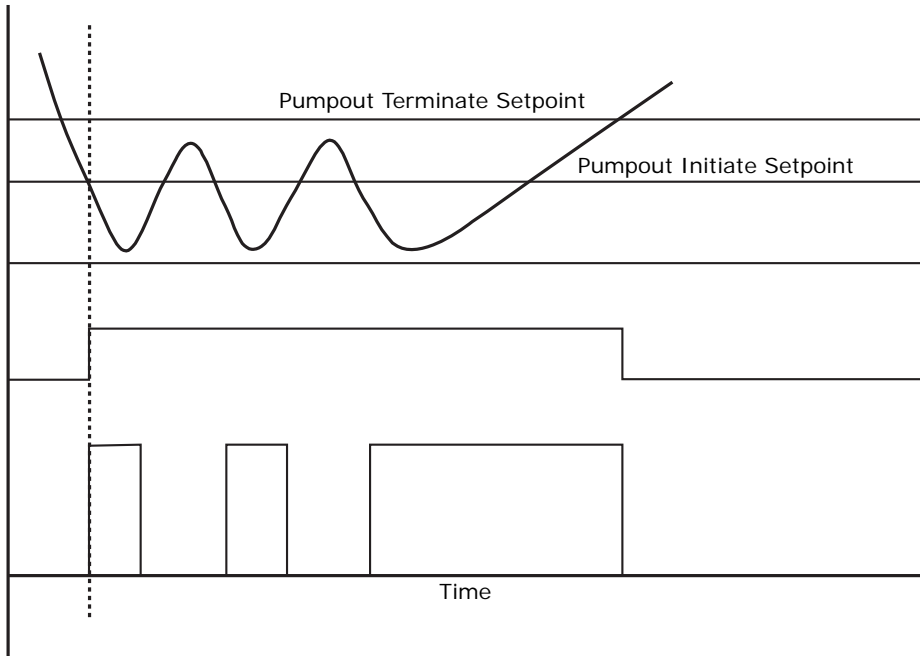
Figure 9. Non-Condensable Pump-out Cycle, Small Quantity of Air

Establishing a Daily Pump-Out Limit

The average pump-out time for a purge system that uses R-123 refrigerant is approximately 7 minutes per day for a one-week period. This value, however, varies widely depending on chiller size, operating conditions, and operating schedule.

Carefully monitor the purge pump-out activity for each chiller for an appropriate period of time (one week or more) in order to establish a baseline value for a Purge Daily Pumpout Limit that is appropriate for that specific installation. Set the Purge Daily Pumpout Limit high enough to avoid nuisance trips, but low enough to trigger an alarm diagnostic, should the pump-out rate suddenly increase. Carefully review [“Troubleshooting,” p. 26](#) and the chiller purge history before making a decision to shut down the chiller for leak testing and repair.

Carbon Tank and Regeneration Subsystem

The function of the carbon tank is to absorb refrigerant molecules that may be entrained in the discharge of non-condensables. In order to maintain effectiveness, the carbon tank periodically regenerates.

Carbon Regeneration Algorithm

The controller uses the carbon regeneration algorithm to determine when to initiate, control, and terminate a carbon regeneration cycle. The carbon bed temperature

sensor serves as the feedback to this algorithm. In addition, the controller uses a pump-out accumulation timer to indicate the remaining carbon capacity in the carbon tank. The carbon capacity is the capacity of the carbon to adsorb refrigerant while maintaining acceptable levels of refrigerant emission through the chiller vent line. A capacity of 100 percent means the carbon bed has the capacity to adsorb refrigerant and maintain acceptable emission levels. A capacity of 0 percent means the carbon bed has inadequate capacity to adsorb refrigerant and still maintain acceptable emission levels.

The main objectives of the carbon regeneration algorithm are to:

- Minimize the amount of refrigerant contained in the carbon by performing a periodic regeneration.
- Regenerate to maintain low emissions levels.
- Minimize the regeneration time.
- Regenerate only when the chiller is at a minimum level of purging activity.
- Allow regeneration to occur with the chiller On or Off. Regeneration is preferable when the chiller is On to ensure low carbon tank pressure, but regeneration is also acceptable when the chiller is Off.

The remaining amount of absorption capacity within the carbon tank is directly proportional to the number of purge pump-out minutes that have accumulated, and is also a function of the chiller refrigerant type. The purge carbon tank on an R-123-equipped chiller is considered to be fully saturated after the purge has accumulated 500 minutes of pump-out time. Because the relationship between pump-

out capacity and pump-out minutes is directly proportional, it can be described by the following equation within the regeneration algorithm:

Remaining carbon capacity% =

$$100 - (\text{pump-out minutes since last regen/pump-out minutes at 100\% capacity}) * 100$$

For example, an R-123-equipped chiller that has accumulated 80 minutes of purge pump-out time since the last carbon tank regeneration would be estimated to have 84 percent carbon tank capacity remaining:

$$100 - (80/500) * 100 = 84\%$$

The purge controls may initiate a carbon tank regeneration cycle when the remaining carbon tank capacity is calculated to be less than 80 percent. However, the continued stable operation of the chiller is always more important than the regeneration of the carbon tank.

Therefore, the following rules apply:

1. If the Daily Pump-out Limit is disabled, a regeneration cycle may not be initiated, regardless of the value of the remaining carbon capacity.
Also, if the Daily Pump-out Limit is disabled during a regeneration cycle, the regeneration cycle must be terminated.
2. When the remaining carbon capacity is less than 80 percent, a regeneration cycle will be initiated at the next opportunity when the chiller is running (after the chiller has started and no pump-out minutes have accumulated for the previous 60 minutes).
3. If there is no opportunity to purge as indicated by Rules 1 and 2 and the remaining carbon capacity is less than 50 percent, a regeneration cycle will be initiated at the best opportunity when the chiller is shut down (and no pump-out minutes have accumulated for the previous 60 minutes).
4. If there is no opportunity to regenerate as indicated by Rules 1, 2, and 3, and the carbon capacity drops below 0 percent, then a regeneration cycle is initiated.
5. Note that if at any time during the regeneration cycle, the chiller is running and shuts down or if the chiller is off and starts up, then the regeneration cycle is continued.

Carbon Tank Regeneration Sequence

WARNING

Hazardous Voltage!

Failure to disconnect power before servicing could result in death or serious injury. Disconnect all electric power, including remote disconnects before servicing. Follow proper lockout/tagout procedures to ensure the power can not be inadvertently energized.

1. Disable the purge refrigeration circuit and the pump-out solenoid valve.
2. Open the regeneration solenoid valve and turn on the carbon tank heater.
3. Monitor the carbon temperature until it reaches the regeneration temperature value of 240°F (115.6°C), and control within a ±10°F (5.5°C) dead band for 15 minutes (this step should take approximately 3 hours).

If the carbon tank temperature exceeds 120 percent of the regeneration temperature setpoint, the controller issues a latching diagnostic, Purge Carbon Regeneration Temperature Limit Exceeded. The purpose of this diagnostic is to identify a failed heater relay or temperature sensor. It disables the purge and opens the exhaust solenoid valve.

If the carbon tank temperature does not increase more than 25°F (16.6°C) in the first two hours, the controller generates a non-latching diagnostic, Carbon Regeneration Temperature Too Low. The purpose of this diagnostic is to identify a failed heater or temperature sensor. It prevents automatic regeneration from occurring, but a service technician can initiate a manual regeneration for testing purposes. All other purge algorithms continue to function.

If the carbon tank temperature does not reach the minimum regeneration temperature setpoint within 4 hours, the controller generates a non-latching diagnostic, Purge Carbon Regen Temperature Not Satisfied. The purpose of this diagnostic is to identify a failing insulation system.

Consult [“Carbon Regeneration Temperature Diagnostic Procedure,” p. 28](#), if a Carbon Regeneration Temperature Setpoint Not Satisfied diagnostic or a Carbon Regeneration Temperature Limit Exceeded diagnostic is generated.

The complete regeneration cycle can take as long as seven hours to accomplish, but an average chiller does not have to regenerate very often. A typical regeneration cycle is depicted in [Figure 10](#).

If the purge controller determine that carbon tank regeneration is desired and is allowed, the purge controls:

Figure 10. Typical carbon regeneration cycle

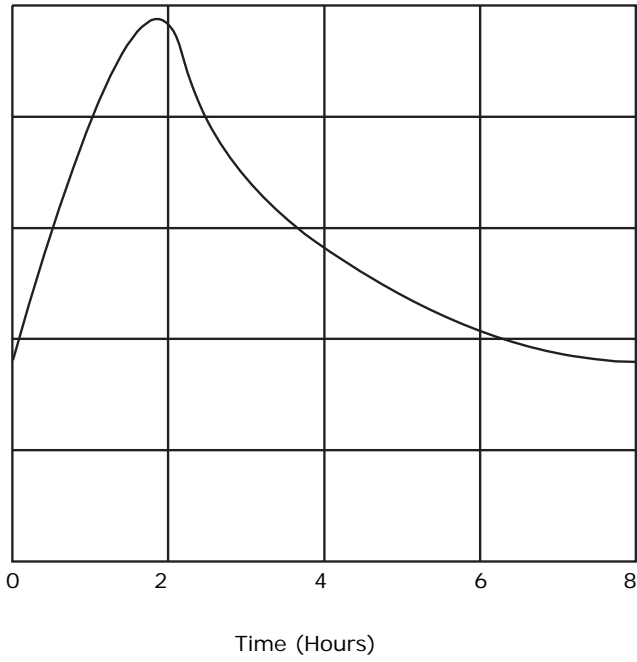



Operator Interface

The Tracer AdaptiView display, which is mounted on the side of the chiller, allows you to monitor chiller status and make changes to its operation, including the purge system. Refer to *Operations Guide: Tracer AdaptiView™ Display for Water-Cooled CenTraVac™ Chillers* (CTV-SVU01*-EN) for a complete description of this display.

This section provides more detail about the purge-related information that you can access through the display.

Reports

From the Reports screen menu, you can access basic operating data for the purge system by selecting one of the following buttons:

- Log Sheet
- ASHRAE Chiller Log
- Purge Operating Modes

Log Sheet

The following status points appear on the Log Sheet:

Note: The same status points appear also on the purge component screen of the Tracer AdaptiView display. The purge component screen is accessible from the purge touch target on the home screen of the display. (Refer to CTV-SVU01-EN.)*

Time Until Next Purge Run. Displayed if the purge is in Adaptive mode and is idle. It indicates the amount of time left on the adaptive cycle timer.

Daily Pumpout—24 Hours. Indicates the daily pumpout time for the last 24 hours (a moving 24-hour window). It indicates how the hermetic integrity of the chiller compares to historic pump-out times for the same chiller. It also allows a check against factory-recommended values.

Average Daily Pumpout—7 Days. Indicates the average daily pump-out time for the last 168 hours (a moving 168-hour window). Enables a comparison of present pump-out times to past averages, and can be another indication of the hermetic integrity of the chiller.

Daily Pumpout Limit/Alarm. Indicates the limit value that an operator has set in the Settings menu. When the daily pumpout rate exceeds this value, purge operation stops and a diagnostic is generated.

Chiller On—7 Days. Indicates the percentage of time during the past 7 days (floating 168-hour window) that the chiller was operating. You can use it to help determine if a leak is present on the high side or the low side of the chiller.

Pumpout Chiller On—7 Days. Indicates the percentage of the total purge pump-out time during the past 7 days that occurred while the chiller was operating.

You can use it to help determine if a leak is present on the high side or the low side of the chiller.

Pumpout Chiller Off—7 Days. Indicates the percentage of the total purge pump-out time during the past 7 days that occurred when the chiller was not operating. You can use it to help determine if a leak is present on the high side or the low side of the chiller.

Pumpout—Life. Indicates the total purge pump-out time that has accumulated over the life of the purge.

Purge Rfgr Cprsr Suction Temp. Indicates the purge refrigerant compressor suction temperature. It is useful for diagnosing purge system problems.

Purge Liquid Temp. Indicates the temperature sensed by the controller and used to inhibit purge operation. The purge liquid temperature sensor, when the chiller is operating, is the chiller saturated condenser temperature sensor; when the chiller is Off, it is the chiller saturated evaporator temperature sensor. If this temperature is below the Pumpout Inhibit Temperature that is defined in the Settings menu, pump out is not allowed. This value is used to prevent inefficient operation of the purge under certain conditions.

Carbon Tank Temp. Indicates the carbon bed temperature and is useful for monitoring regeneration and for diagnosing regeneration system problems.

Purge Operating Modes

The Purge Operating Mode screen displays the current mode and up to six submodes of operation for the purge system. Only one mode can be active at a time, while several submodes can be active simultaneously. (For more information on this subject, refer to [“Purge Operating Modes,” p. 10.](#))

Modes

The four available modes of purge operation are:

- Stop
- On
- Auto
- Adaptive

Submodes

You can view up to six purge submodes from the Purge Settings screen. The available purge submodes are:

Refrigeration Circuit On. appears if the purge condensing unit/compressor is operating.

Refrigeration Circuit Idle. appears if the purge condensing unit/ compressor is not operating.

Pumping Out. appears if the purge refrigeration circuit is On and pump-out has been initiated by the purge unit controls.



Operator Interface

Exhaust Circuit Check. appears if a pump-out has been initiated by an operator.

Pumpout Inhibited. appears if the purge refrigeration circuit is On but pump-out has been inhibited by a low condenser saturation temperature.

Daily Pumpout Limit Disabled. appears if the purge refrigeration circuit is On but the daily pump-out limit has been disabled.

Regenerating. appears if the purge carbon system is in its regeneration mode. Pump-out is not allowed in this submode.

Alarm-Check Diagnostics. appears if a new diagnostic occurs.

Purge Diag Shutdown. appears if the purge system has shut down in response to a latching diagnostic.

Regen Disabled. appears if carbon regeneration is not allowed.

Settings

The Tracer AdaptiView display enables you to manually select operating modes and setpoints that are appropriate for a specific chiller application. The Settings screen menu contains two buttons that provide access to purge-related settings:

- Purge Settings
- Manual Control Settings

Purge Settings

The following purge settings are available:

Purge Mode. Use it to set the purge operating mode.

Daily Pumpout Limit. Use it to set the allowable amount of daily pump-out time. The range is from 1 to 50 minutes; the factory default is 10 minutes.

Disable Daily Pumpout Limit. Use it to disable alarms for a specified time that are associated with exceeding the daily pumpout limit. This is useful when large amounts of purging are needed following chiller servicing or operator error. The range is from 0 to 72 hours, the factory default is 0 hours. Any setting greater than 0 hours will effectively disable the Daily Pumpout Limit for the amount of time selected.

Purge Liquid Temp Inhibit. Use it to enable or disable the inhibit feature that prevents purge pump-out if the sensed purge liquid temperature is less than the pump-out inhibit value.

Purge Liquid Temperature Limit. Use it to define the setpoint for the Purge Liquid Temp Inhibit feature. If the sensed chiller refrigerant temperature is below this value, pump-out will not be allowed. The allowable range is 32°F (0.0°C) to 50°F (10.0°C). Factory default is 40°F (4.4°C).

Manual Control Settings

The manual control settings that affect purge operation are as follows:

Purge Exhaust Circuit Test. On/Off, Auto/On. Factory default is Off. If set to On, the system initiates a 30-second non-condensable pumpout cycle. This setting can be used to check exhaust circuit components.

Purge Regen Cycle. On/Off, Auto/On. Factory default is Off. Use this setting to manually start a carbon regeneration cycle.

Note: This setting is also accessible from the purge component screen of the Tracer AdaptiView display; refer to Operations Guide: Tracer AdaptiView™ Display for Water-Cooled CenTraVac™ Chillers (CTV-SVU01-EN).*

Alarms

You can view and reset diagnostics from the Alarms screen of the Tracer AdaptiView display. For more information about the display, refer to CTV-SVU01*-EN. For information about troubleshooting using purge diagnostics, see [“Troubleshooting,” p. 26.](#)



Maintenance

Maintenance requirements for an EarthWise purge system with Tracer AdaptiView control are described in this section. To ensure efficient and reliable purge operation, perform all inspections and procedures at the prescribed intervals. Keep records of inspection results to establish proper service intervals. Document changes that occur in purge activity that could provide information about chiller performance.

⚠ WARNING

Refrigerant under High Pressure!

Failure to follow instructions below could result in an explosion which could result in death or serious injury or equipment damage. System contains oil and refrigerant under high pressure. Recover refrigerant to relieve pressure before opening the system. See unit nameplate for refrigerant type. Do not use non-approved refrigerants, refrigerant substitutes, or refrigerant additives.

⚠ WARNING

Hazardous Voltage!

Failure to disconnect power before servicing could result in death or serious injury. Disconnect all electric power, including remote disconnects before servicing. Follow proper lockout/tagout procedures to ensure the power can not be inadvertently energized.

⚠ CAUTION

Hot Surface!

Failure to follow instructions below could result in minor to moderate injury. Surface temperatures may exceed 300°F (150°C) on condensing unit and carbon tank. To avoid possible skin burns, stay clear of these surfaces. If servicing is required allow surfaces to cool or wear protective gear.

Weekly Maintenance

Perform the following maintenance procedure on a weekly basis:

1. With the purge unit operating, check the purge tank condensing activity by observing the liquid refrigerant flow in the moisture-indicating sight glass located in the liquid drain line immediately after the filter drier canister. A lack of visible refrigerant flow in the sight glass indicates one of the following:
 - A pump-out cycle is necessary
 - A problem exists with the purge heat transfer circuit (such as the condensing unit, expansion device, or purge evaporator coil)
 - A problem exists in the purge control subsystem

- Refrigerant vapor from the chiller condenser is blocked or restricted
2. Check the moisture-indicator sight glass. Replace the filter-drier core if moisture is indicated.

Note: The need for frequent changes of the filter drier could be an indication of significant chiller air or tube leaks.

Semi-Annual Maintenance

Perform the following maintenance procedure on a semi-annual basis:

1. Inspect the air-cooled condenser coil and clean as needed. Clean the coil from the fan side using compressed air or coil cleaner. A dirty coil will reduce purge efficiency and capacity.
2. Inspect the purge tank and carbon tank insulation for any damage or degradation. Make any needed repairs to the insulation.

Annual Maintenance

Perform the following maintenance procedure on an annual basis:

1. Perform the semi-annual maintenance procedures.
2. Perform the purge system control checks described in "Troubleshooting," p. 26.
3. Open the purge control panel and check all internal components for such problems as corrosion, terminal tightness, or signs of overheating.
4. Change the filter-drier assembly.

Replacing the Filter-Drier Assembly

Following are maintenance instructions for filter-drier assembly replacement; refer to [Figure 1, p. 6](#), for the location of this component.

1. At the Tracer AdaptiView display, touch the Settings button to display the Settings screen. Touch the Purge Settings button to display the Purge Settings screen. Touch Purge Mode to display Purge Mode screen. From this screen, set the mode to Stop.
2. Isolate the purge unit from the chiller. Close the isolation valves on the purge vapor inlet and the liquid return lines.
3. Drain the filter-drier of liquid refrigerant prior to opening. Use available pressure differential whenever possible. Connect a refrigeration hose to the 1/4-inch Schrader drain fitting located on the drain line isolator valve and also to a service valve on the chiller evaporator. Open the chiller valve and drain the filter-drier.
4. Remove the refrigerant vapor from inside the filter-drier by connecting the suction side of a vacuum pump to the Schrader drain fitting and the discharge side to

Maintenance

the chiller. Pull a vacuum for approximately 30 minutes.

Notes:

- Due to the slow out-gassing of refrigerant from the filter-drier, it will not be possible to pull and hold a deep vacuum.
- The replacement filter-drier absorbs water vapor from the ambient air, so it is shipped with sealing caps on each end. Do not remove these caps until immediately before installation.

Figure 11. Filter-drier assembly

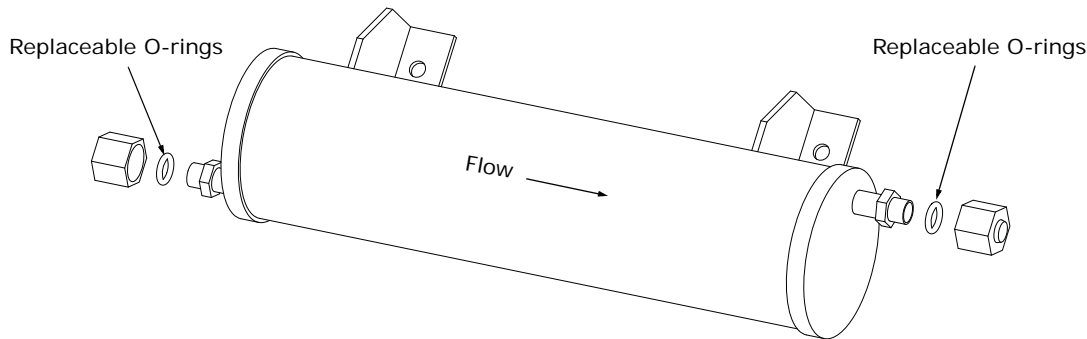

9. Pressurize the purge with dry air or nitrogen to 10 psig (68.9 kPaG) through the Shrader drain valve. Then check for leaks.
10. Release the pressure, remove hoses, and replace all valve caps.
11. Set the purge operating mode to “On” and wait for the purge pump-out compressor to start.
12. Open the isolation valves on the vapor inlet lines and the liquid return line.
13. After purge pump-out stops, or after several minutes, return the purge operating mode to Auto or Adaptive (recommended) using the Tracer AdaptiView display.

Inspecting the Moisture Indicator

Monitor the quality of the liquid refrigerant in the chiller by periodically inspecting the moisture indicator. The indicator will show “wet” whenever the chiller moisture exceeds the levels shown in [Table 1](#). Notice that the indicator becomes more sensitive as the temperature decreases. (The moisture indicator normally operates at equipment room ambient temperatures.)

A “wet” indication for more than 72 hours typically indicates that the filter-drier is saturated and should be replaced. In some cases in which a substantial amount of moisture has accumulated, such as when the chiller has been serviced, several filter-drier assembly changes may be required before a satisfactory moisture level is achieved. A reoccurring or persistent “wet” indication is a sign of possible chiller air or water infiltration.

Inspect the moisture indicator only under the following conditions:

5. Remove the screws connecting the filter-drier to the purge base. Loosen the nuts at each end of the filter-drier and slide it out from the adjacent tubing.
6. Immediately cap the two ends with the caps from the replacement filter-drier.
7. Dispose of the old filter-drier in accordance with local regulations.
8. Install the new filter-drier using new O-rings supplied with the assembly ([Figure 11](#)).

- The chiller is operating.
- The purge unit is operating and has been allowed sufficient time to properly remove system moisture (allow a minimum of 72 hours after replacing filter-drier).

Table 1. Refrigerant moisture content as determined by moisture indicator

Refrigerant moisture level	R-123		
	75°F (23.9°C)	100°F (37.8°C)	125°F (51.7°C)
Dry	Below 20	Below 30	Below 35
Caution	20–50	30–80	35–100
Wet	Above 50	Above 80	Above 100

Note: Refrigerant moisture content given in parts per million (ppm).

Maintaining the Moisture-Indicating Sight Glass

In normal operating conditions, the moisture-indicating sight glass should not require maintenance beyond keeping the sight glass clean. However, the sight glass should be replaced after any major repair to the unit has taken place, or if it is on a unit in which severe moisture contamination is known to have occurred.

Be aware that it is normal for the sight glass to indicate the presence of moisture for a period of least 72 hours after it is installed and after it has been exposed to atmosphere. Allow a minimum of 72 hours after sight glass installation or filter-drier service before using the sight glass to determine the system moisture content.

Removing Air After Servicing the Chiller

Air that leaks into a chiller during servicing needs to be removed so that the chiller can operate normally. The purge pump-out system, which performs this function, may operate for a long time to remove the air before cycling off for the first time. This is due to the large amount of non-condensables and the relatively small amount of refrigerant being drawn into the purge tank.

Important: Do not bypass or remove the pump-out restrictor of the EarthWise Purge system. Doing so could reduce the efficiency of the purge system. The purge system has a faster air exhaust rate than previous purge systems, which makes bypassing or removing the restrictor unnecessary.

The Daily Pumpout Limit determines how long the purge pump-out compressor can operate continuously without generating a Purge Daily Pumpout Exceeded diagnostic, which will shut off the purge system. You can disable the Daily Pumpout Limit to allow the purge to pump out for an extended period of time.

Disable the Daily Pumpout Limit by using the Tracer AdaptiView display as follows:

1. Touch the Settings button to access the Settings menu screen.
2. Touch the Purge Settings button to access the Purge Settings screen.
3. Touch the Purge Disable Daily Pumpout Limit button. A screen with the current value and a keypad appears. Use the keypad to enter a new value. Any setting greater than 0 hours will effectively disable the Daily Pumpout Limit for the amount of time selected. The range of available settings is from 1 to 72 hours in 1-hour increments. Typically, 24 hours is sufficient. After the selected time has expired, the Disable Daily Pumpout Limit automatically de-energizes and returns the purge system to normal operation.

Once the level of non-condensables present in the chiller falls to a point in which an increasing amount of refrigerant enters the purge tank, the pump-out compressor begins to cycle on and off. As the refrigerant in the system becomes less contaminated with non-condensables, purge pump-out is activated less frequently.

Note: If large amounts of non-condensables are present in the chiller, the air removal rate can be enhanced by operating the chiller at part-load conditions.



Troubleshooting

Use this section to assist you in diagnosing operational problems with the purge system.

⚠ WARNING

Refrigerant under Positive Pressure!
 Failure to follow instructions below could result in an explosion which could result in death or serious injury or equipment damage. System contains oil and refrigerant and may be under positive pressure. Recover refrigerant to relieve pressure before opening the system. See unit nameplate for refrigerant type. Do not use non-approved refrigerants, refrigerant substitutes, or refrigerant additives.

⚠ WARNING

Hazardous Voltage!
 Failure to disconnect power before servicing could result in death or serious injury. Disconnect all electric power, including remote disconnects before servicing. Follow proper lockout/tagout procedures to ensure the power can not be inadvertently energized.

⚠ CAUTION

Hot Surface!
 Failure to follow instructions below could result in minor to moderate injury. Surface temperatures may exceed 300°F (150°C) on condensing unit and carbon tank. To avoid possible skin burns, stay clear of these surfaces. If servicing is required allow surfaces to cool or wear protective gear.

Diagnostics

The chiller controller generates diagnostics to alert the operator to abnormal conditions. There are two kinds of diagnostics:

- Non-latching diagnostics: Operation continues. Alarms resolve themselves and the alarm disappears. They are informational only.
- Latching diagnostics: Operation stops until the condition is corrected and the diagnostic has been manually reset from the Tracer AdaptiView display or from the Tracer TU service tool.

Table 2, p. 26, describes the causes of diagnostics and operating problems that can occur with purge systems, and suggests solutions to resolving them.

Table 2. Troubleshooting a purge system

Diagnostic or Problem	Cause	Solution
Purge Cprsr Suction Temp Sensor (latching diagnostic)	Bad Sensor or LLID	The purge refrigerant compressor suction temperature sensor has failed. The connection has been broken or a short has occurred in the wiring, or the LLID is not programmed or functioning correctly. Replace or repair as required.
Purge Liquid Temp Sensor (latching diagnostic)	Bad Sensor or LLID	The purge liquid temp sensor has failed. The connection has been broken or a short has occurred in the wiring, or the LLID is not programmed or functioning correctly. Replace as required.
Purge Carbon Tank Temp Sensor (latching diagnostic)	Bad Sensor or LLID	The purge carbon tank temp sensor has failed. The connection has been broken or a short has occurred in the wiring, or the LLID is not programmed or functioning correctly. Replace as required.
Purge Liquid Level Too High (nonlatching diagnostic)	High liquid level in purge tank or bad level switch. The level switch was open for at least 20 minutes.	Check for restrictions in the in the vapor pick-up line and in the liquid return line. Ensure the vapor line is sloped correctly and has no liquid traps. Change filter drier if required. Ensure the line shutoff valves are open.
Purge Liquid Level Too High Continuously (latching diagnostic)	High liquid level in purge tank or bad level switch. The level switch was open for more than 20 minutes, or the liquid level/ refrigeration circuit restart cycle has occurred more than four times in 4 hours.	Check for restrictions in the in the vapor pick-up line and in the liquid return line. Ensure the vapor line is sloped correctly and has no liquid traps. Change filter drier if required. Ensure the line shutoff valves are open.
Purge Carbon Regen Temp Too Low (non-latching diagnostic)	The carbon tank temperature did not increase more than 25°F (-3.9°C) in the first 2 hours after energizing the carbon tank heater.	This diagnostic is intended to identify a failed heater or sensor. Check carbon tank heater and heater wiring. Check the carbon tank temperature sensor and it's wiring. Check the carbon tank insulation and the surrounding ambient temperature. Check the purge unit controls and settings.
Carbon Regeneration Temperature Setpoint Not Satisfied (non-latching diagnostic)	The carbon tank temperature sensor did not reach the minimum regeneration temperature setpoint within 4 hours after energizing the heater.	This is intended to identify a failing insulation system. Check carbon tank insulation for integrity. Check ambient conditions. Check heater operation.

Table 2. Troubleshooting a purge system (continued)

Diagnostic or Problem	Cause	Solution
Carbon Regeneration Temperature Limit Exceeded (latching diagnostic)	The carbon tank temperature exceeded 120% of the regeneration temperature setpoint. The carbon tank temperature did not decrease more than 25°F (-3.9°C) in the first hour after the heater is turned off.	Check carbon tank heater relay and heater wiring. Check the carbon tank temperature sensor and its wiring. Check the purge unit controls and settings.
Purge Daily Pump-out Limit Exceeded latching diagnostic)	The pump-out time recorded over the past 24 hours has exceeded the daily pump-out limit setpoint.	Air infiltration rate into chiller may be too high, leak check chiller and repair leaks. The daily pump-out limit setpoint may be set too low. Check and adjust to proper value. The chiller refrigerant temperature may be too low. Do not operate purge at condensing temps of 40°F (4.4°C) or lower. High vacuum pump-outs may be operated down to 32°F (0.0°C). Set pump-out inhibit to Enable and set appropriate limit.
Comm Loss: xxxx (latching diagnostic)	A loss of communication of more than 30 continuous seconds has occurred between the controller and the identified component (LLID).	Check the LLID and the interconnecting Machine bus. Check the LLID configuration and function using the Tracer TU service tool.
Purge unit does not run or pump-out system does not run.	Control circuit problem.	Run diagnostics of purge control system. Refer to the control circuit test. Check the purge control for active diagnostics. Check the purge control system using the Tracer TU service tool.
Purge continues to operate when chiller is Off.	Purge is set to On or to Adaptive operating mode.	Check operating mode. The On mode should be used only for specific service procedures; Adaptive is the normal operating mode.
Pump-out compressor operates continuously. Purge refrigerant compressor suction temperature is greater than the pump-out initiate setpoint.	Purge refrigerant compressor suction temperature sensor has failed. The control system has failed.	Check sensor, LLID, and Machine bus. Check the controller by using diagnostic tools.
Purge fails to pump-out non-condensables. Chiller observations indicate air is actually present in the chiller; that is, measured condenser pressure is greater than measured condenser temperature converted to pressure, and/ or chiller surges at start-up.	Depending on the chiller type and the operating conditions, air may accumulate in the chiller condenser away from the purge vapor pick-up location. (retrofit purge)	Operate the purge with the chiller Off. Any air in the chiller will be removed if the purge is functioning correctly. If a large amount of air is removed, leak test the chiller and repair leaks. Consider using the Adaptive mode to run the purge as required when the chiller is Off. If non-condensable removal is required during chiller operation, relocate the vapor/liquid connections to a more effective location.
	Pump-out restrictor plugged.	Clean out restrictor orifice with compressed air (preferred) or a small wire.
	Purge condensing unit is overcharged or undercharged.	Refer to the "Carbon Regeneration Temperature Diagnostic Procedure," p. 28 to evaluate the purge charge level.
	Purge expansion valve has failed.	Refer to the "Carbon Regeneration Temperature Diagnostic Procedure," p. 28 to evaluate the purge expansion valve performance.
	Pump-out circuit fault.	Run diagnostic of purge control circuit. Refer to control circuit test.
	Purge condensing unit fan has failed.	Test and replace fan as needed.
	Purge condensing unit condenser coil is fouled.	Clean condenser coil as required.
	Condensing unit compressor motor winding temperature sensor opened (line break t-stat)	Check condensing fan and coil. Check purge condensing unit charge level. Check purge condensing unit compressor. Check purge power supply. Replace line break protector if needed. Replace compressor if needed.
	Pump-out compressor fault—does not run	Low voltage, no voltage, failed pump motor, failed controls.
	(Continued from previous page)	Pump-out compressor fault—pump motor runs
	Purge refrigerant compressor suction temperature sensor	Not installed correctly or the thermal conductive paste has degraded. Correct orientation of installed sensor and install thermal conductive paste.

Troubleshooting

Table 2. Troubleshooting a purge system (continued)

Diagnostic or Problem	Cause	Solution
Pump-out compressor operates continuously.	Purge is set to Auto mode and the chiller run signal has failed.	Check the chiller run signal (retrofit purge). Check the controller system.
Purge refrigerant compressor suction temperature is less than the pump-out initiate value.	Excessive air in chiller.	Trace air source and repair any leak paths. Allow purge to remove accumulated air.
	Leakage in purge or purge pump-out tubing.	Check all connections on purge and between the purge tank and the pump-out compressor. Check all solenoid and other valves for possible leakage.
	Failed or restricted solenoid.	Failure of the pump-out solenoid to open, or a failure of the exhaust solenoid to open. Check for dirt or contamination, failed or misaligned armature, or an incorrect control command from the controller.
	Pump-out restrictor plugged.	
	Gas pick-up connection of the purge is below the liquid level of the condenser.	Refer to the installation instructions of a retrofit purge. Check overall unit operation.
	Gas pick-up or return line restricted.	Ensure shut-off valves are fully open and remove any restrictions.
	Restriction in exhaust lines.	Check carbon tank for restriction, check solenoid valves for restriction, check outlet tubing from the carbon tank to the chiller vent line.

Carbon Regeneration Temperature Diagnostic Procedure

If a Carbon Regeneration Temperature Setpoint Not Satisfied diagnostic is generated, follow this procedure:

1. Close the regeneration solenoid valve and turn off the heater.
2. Reset the calculated carbon capacity to 100 percent.
3. Turn the purge refrigeration circuit on and allow the carbon tank to cool for 4 hours or until the carbon temperature reaches 100°F (37.8°C), whichever comes first.

If the carbon tank temperature does not decrease more than 25°F (13.8°C) in the first hour after this procedure, the controller initiates a latching diagnostic, Carbon Regeneration Temperature Limit Exceeded. The purpose of this diagnostic is to identify a failed heater relay or temperature sensor. This diagnostic disables the purge system and opens the exhaust solenoid valve.

If a Carbon Regeneration Temperature Limit Exceeded diagnostic is generated, follow this procedure.

1. Open the exhaust solenoid for 5 minutes and then close it.
2. Run the refrigeration circuit for 15 minutes. Operating the refrigeration circuit during the carbon cool-down cycle allows time for any gas that may have remained in the carbon tank to accumulate in the purge tank.
3. While the refrigeration circuit is running, enable pump-outs. If enough gas has accumulated in the purge tank, a pump-out cycle is activated following completion of the cool-down cycle

Purge Refrigeration Circuit Diagnostic Procedures

You can troubleshoot the refrigeration circuit by taking surface temperature measurements and using them to diagnose specific problems, as explained in this section.

Taking Surface Temperature Measurements

While the purge condensing unit is running, take temperature readings with an accurate ($\pm 1^\circ\text{F}$ [0.55°C]) surface-mounted thermocouple-type temperature probe that has a range of -40°F (-40.0°C) to 200°F (93.3°C). The locations to be measured are shown in [Figure 5, p. 14](#). The temperatures that you should expect to find under typical operating conditions are given in the same figure.

1. To ensure accurate measurements, remove any ice that may exist on measuring surfaces before attaching the probe.
2. Fasten the sensor of the probe tightly against the tubing surface and insulate around the sensor for accurate results.
3. To measure the temperature at location 1, move aside a small portion of the insulation covering the tubing between the expansion valve and the purge tank.
4. To read the purge refrigerant compressor suction temperature, view the purge component screen of the Tracer AdaptiView display. Then confirm that reading by measuring the temperature with a surface-mounted thermocouple at location 2.
5. To measure the compressor discharge temperature, mount the probe on the surface at location 3.
6. To measure the condenser temperature (location 4), remove the sheet metal cover from the side of the condenser and measure the surface temperature of the

second or third from the top condenser tubing U-bend on the side of the coil opposite the discharge gas inlet.

- To measure the liquid line temperature, measure the tubing between the purge condenser and the expansion valve (location 5).

Determining the Refrigerant Charge Level

To operate correctly, the purge refrigeration system must have a proper charge level of R-404A. The charge level should be determined before any other refrigeration circuit components are evaluated.

- Take the surface temperature measurements for locations 1–5 as described in [“Taking Surface Temperature Measurements,” p. 28.](#)
- Calculate the difference between locations 4 and 5.

The difference is the sub-cooling value. If the system is properly charged with R-404A, the sub-cooling value should be between 8°F (4.4°C) and 15°F (8.3°C).

- A sub-cooling of less than 5°F (2.8°C) indicates a possible refrigerant undercharge and a possible leak.
- A sub-cooling value greater than 20°F (11.0°C) indicates a refrigerant overcharge.

Determining Proper Expansion Valve Operation

The purpose of the expansion valve is to regulate refrigerant flow so that a constant pressure is maintained within the purge tank coil. A constant pressure results in a constant temperature of the refrigerant that is entering the purge tank.

Table 3. Purge component status

Displayed purge status	Condensing unit	Pump-out compressor	Pump-out solenoid	Exhaust solenoid	Regeneration solenoid	Carbon tank heater
Refrigerant Circuit On	•	o	o	o	o	o
Refrigerant Circuit Idle	o	o	o	o	o	o
Pumping Out	•	•	X	•	o	o
Regenerating	X	o	o	o	X	X
Exhaust Circuit Check	•	•	•	•	o	o
Pumpout Inhibited	•	o	o	o	o	o
Daily Pumpout Limit Disabled	•	X	X	X	o	o
Purge Diag Shutdown	o	o	o	o	o	o

Notes:

- o = or de-energized
- = On or energized
- X = cycling on internal algorithm

To determine if the expansion valve is operating properly, measure the temperature at location 1, as described in [“Taking Surface Temperature Measurements,” p. 28.](#) An optimum constant temperature of -16°F (-26.6°C) is ideal. However, an acceptable range, to allow for errors or operating conditions, is between -20°F (-28.9°C) and -10°F (-23.3°C).

Determining Correct Vapor Pick-up and Liquid Return Line Connection Locations

To ensure correct purge operation, make sure that the vapor pick-up and liquid return connections are properly located on the chiller condenser, and are properly sloped, as described:

- During chiller operation, non-condensables accumulate in the coolest, calmest spot in the condenser above the liquid level. On a Trane® chiller this location is typically just under half-way up the condenser shell above the condenser sump. An internal baffle has been installed to enhance this process during chiller operation. During chiller Off cycles, non-condensables may rise to higher elevations within the chiller. However, during purge system operation, a continuous thermal siphon develops that effectively draws the non-condensables into the purge tank.
- Vapor pick-up and liquid return lines must be sloped a minimum of 2 inches per foot off horizontal or vertical to ensure that no liquid or vapor traps exist.

Using the Service Functions

Service functions allow you to take manual control to test the operation of specific functions. Refer to [Table 3](#) as you test the functions in this section.

Purge Regen Cycle

The Purge Regen Cycle is a manual control setting that allows you to manually initiate a carbon tank regeneration cycle.

Note: This test can be initiated from either the Tracer AdaptiView display or the Tracer TU service tool.

Run this cycle to:

- Observe the purge condensing unit stopping
- Observe the pumpout solenoid closing (if open)
- Observe the regeneration solenoid opening
- Observe the carbon tank heater energizing
- Verify that regeneration setpoints are achieved
- Verify that timing functions are correct

For more information regarding this feature, see "[Carbon Tank Regeneration Sequence](#)," p. 19.

Purge Exhaust Circuit Test

The Purge Exhaust Circuit Test is a manual control setting that you can use to check that the components activate in the right sequence and at the right time when commanded to do so by the controls.

Note: This test can be initiated from either the Tracer AdaptiView display or the Tracer TU service tool.

This feature, when enabled, overrides the pump-out algorithm and executes a pump-out sequence, regardless of the actual purge refrigerant compressor suction temperature. Once activated, the pump-out sequence continues for 30 seconds. During this time, you can observe and confirm that the pump-out compressor starts and the exhaust solenoid opens. After 5 seconds, you should also be able to observe the pump-out solenoid opening.

Exhaust Circuit Pressure Check

The Exhaust Circuit Pressure Check enables the servicing technician to check the exhaust circuit components and lines for leakage by pressurizing the exhaust circuit.

Note: This test can be initiated from only the Tracer TU service tool.

To perform this test, follow this procedure:

1. Install a pressure gauge, isolation valve, pressure regulator, and a source of dry compressed air or nitrogen to the line downstream of the exhaust solenoid valve. When this check is enabled, the exhaust solenoid opens.
2. Pressurize the exhaust circuit to no more than 10 psi (68.9 kPa) using dry air or nitrogen.
3. After the target pressure is achieved, isolate the pressure source and monitor the pressure gauge for decay. A loss of pressure indicates leakage from the exhaust system.

4. Test the exhaust components and line connections for leaks by using a soap solution.
5. Relieve the testing pressure from the exhaust circuit before disabling this test. When the test is disabled the exhaust solenoid valve re-closes.

Exhaust Circuit Vacuum Check

The Exhaust Circuit Vacuum Check enables the servicing technician to check the exhaust circuit components and lines for leakage by placing a vacuum on the exhaust circuit.

Note: This test can be initiated from only the Tracer TU service tool.

To perform this test, the servicing technician should follow this procedure:

1. Install a vacuum gauge, isolation valve, and a vacuum source to the line downstream of the exhaust solenoid valve. When this check is enabled, the exhaust solenoid opens.
 2. Turn on the vacuum source and pull the exhaust circuit to as deep a vacuum as can be achieved.
 3. After a vacuum is achieved, isolate the vacuum source and monitor the vacuum gauge for decay. A rise in pressure indicates leakage into the exhaust system.
- Note: Out-gassing of refrigerant from the carbon tank may give a false indication of a pressure rise.*
4. Relieve the vacuum from the exhaust circuit before disabling this test. When the test is disabled the exhaust solenoid valve re-closes.



Specifications

An EarthWise purge system has the specifications shown in the following table.

Electrical power requirements	115 Vac, 60 Hz, 1-phase, 10.3 A 110 Vac, 50 Hz, 1-phase, 10.3 A Voltage range is +10%, -15%
Purge compressor motor rated-load ampacity	8 RLA
Total unit ampacity	10.3 A
Minimum circuit ampacity	12.3 A
Carbon tank heater wattage	175 W
Alarm relay output rating	120 Vac, 1/3 hp, 7.2 FLA
Operating temperature range	34°F to 110°F (1.1°C to 43.3°C)
Storage temperature range	-40°F to 150°F (-40.0°C to 65.5°C)
Storage and operating humidity range	5% to 95% relative humidity, non-condensing
Mounting	Direct-mounted on condenser shell above the liquid level of highest condenser
Dimensions (approximate)	25-3/4 in. (65.4 cm) high x 27-1/2 in. (69.9 cm) wide x 21-3/4 in. (55.2 cm) deep, with filter-drier
Weight	140 lb (63.5 kg) with filter-drier
Condensing unit refrigerant charge	0.60 lb (0.27 kg) of R-404A



EarthWise Purge System Model Number

Each Trane EarthWise purge system is assigned a alphanumeric model number that identifies the operating components and option for that specific unit. The model

number is printed on the unit nameplate. It is important to refer to the model number when ordering parts or requesting technical assistance.

Figure 12. Example of a typical nameplate

MODEL NO: PRGDA011AA00
 SERIAL NO: L01G09795
 RATED VOLTAGE: 110/50/1,115/60/1
 TOTAL UNIT AMPS: 10.3 AMPS
 MIN CKT AMPACITY: 12.3 AMPS
 MAX OVERCURRENT
 PROTECTIVE DEVICE: 15 AMPS
 FACTORY CHARGED: 0.60 LBS OF R404a
 DESIGN PRESSURE: HIGH SIDE 335 PSIG
 LOW SIDE 175 PSIG
 UNIT SUITABLE FOR USE
 WITH REFRIGERANTS: R123
 SERVICE LITERATURE: PRGD-SVN01D-EN
 PRGD-SVU01C-EN
 MANUFACTURED UNDER ONE OR MORE OF THE LISTED U.S.
 PATENTS OWNED BY
 AMERICAN STANDARD INC.: 5,031,410

An explanation of the purge system model number is shown in [Table 4](#).

Table 4. Model number explanation

Model number example: PRGDA011AA00			
Feature	Digits	Model number	Explanation
Unit type	1,2,3	PRG	Purge
Development sequence	4	A	First generation
		B	Second generation
		C	Third generation
		D	Fourth generation
Enclosure type	5	A	Standard
		B	NEMA 4
		C	NEMA 4 with Hersite condensing unit
		S	S = special
Control options	6	0	Without power supply
		1	With power supply
		2	Condenser pressure cutout—standard
		3	Condenser pressure cutout—ASME
Control interface	7	0	Chiller interface
		1	Purge interface
Frequency	8	1	60 Hz
		2	50 Hz
Vacuum pump	9	A	Standard vacuum pump
		B	High vacuum pump
Design sequence	10, 11	A0	Original
Special options	12	0	None
		S	Special



Schematic Wiring Diagram

EarthWise Purge System with Tracer AdaptiView Controls

⚠ WARNING

Hazardous Voltage w/Capacitors!

Failure to disconnect power and discharge capacitors before servicing could result in death or serious injury. Disconnect all electric power, including remote disconnects and discharge all motor start/run capacitors before servicing. Follow proper lockout/tagout procedures to ensure the power cannot be inadvertently energized. For variable frequency drives or other energy storing components provided by Trane or others, refer to the appropriate manufacturer's literature for allowable waiting periods for discharge of capacitors. Verify with an appropriate voltmeter that all capacitors have discharged.

For additional information regarding the safe discharge of capacitors, see PROD-SVB06-EN*

NOTICE:

Use Copper Conductors Only!

Failure to use copper conductors could result in equipment damage as unit terminals are not designed to accept other types of conductors.



Trane optimizes the performance of homes and buildings around the world. A business of Ingersoll Rand, the leader in creating and sustaining safe, comfortable and energy efficient environments, Trane offers a broad portfolio of advanced controls and HVAC systems, comprehensive building services, and parts. For more information, visit www.Trane.com.

Trane has a policy of continuous product and product data improvement and reserves the right to change design and specifications without notice.

© 2015 Trane All rights reserved
PRGD-SVX01D-EN 14 May 2015
Supersedes PRGD-SVX01C-EN (24 Feb 2014)

We are committed to using environmentally
conscious print practices that reduce waste.

