



**TRANE®**

# Operation and Maintenance Guide

---

## EarthWise™ Purge With CH530

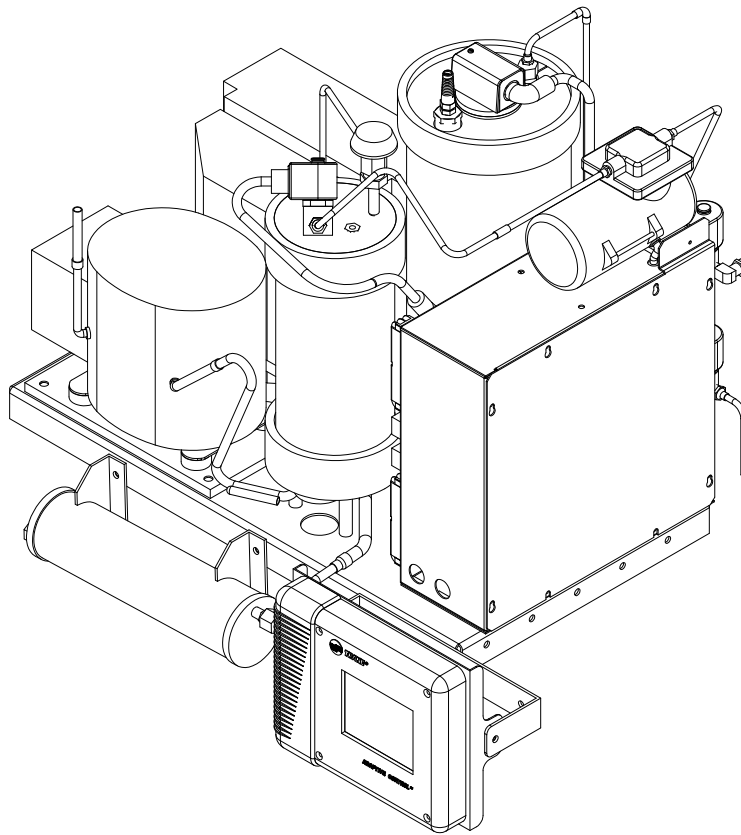

X39640731020

---

July 2010

**PRGD-SVU01C-EN**





# Warnings, Cautions and Notices

**Warnings, Cautions and Notices.** Note that warnings, cautions and notices appear at appropriate intervals throughout this manual. Warnings are provided to alert installing contractors to potential hazards that could result in personal injury or death. Cautions are designed to alert personnel to hazardous situations that could result in personal injury, while notices indicate a situation that could result in equipment or property-damage-only accidents.

Your personal safety and the proper operation of this machine depend upon the strict observance of these precautions.

**ATTENTION:** Warnings, Cautions and Notices appear at appropriate sections throughout this literature. Read these carefully.

 **WARNING:** Indicates a potentially hazardous situation which, if not avoided, could result in death or serious injury.

 **CAUTION:** Indicates a potentially hazardous situation which, if not avoided, could result in minor or moderate injury. It could also be used to alert against unsafe practices.

**NOTICE:** Indicates a situation that could result in equipment or property-damage-only accidents.

## Important Environmental Concerns!

Scientific research has shown that certain man-made chemicals can affect the earth's naturally occurring stratospheric ozone layer when released to the atmosphere. In particular, several of the identified chemicals that may affect the ozone layer are refrigerants that contain Chlorine, Fluorine and Carbon (CFCs) and those containing Hydrogen, Chlorine, Fluorine and Carbon (HCFCs). Not all refrigerants containing these compounds have the same potential impact to the environment. Trane advocates the responsible handling of all refrigerants-including industry replacements for CFCs such as HCFCs and HFCs.

## Responsible Refrigerant Practices!

Trane believes that responsible refrigerant practices are important to the environment, our customers, and the air conditioning industry. All technicians who handle refrigerants must be certified. The Federal Clean Air Act (Section 608) sets forth the requirements for handling, reclaiming, recovering and recycling of certain refrigerants and the equipment that is used in these service procedures. In addition, some states or municipalities may have additional requirements that must also be adhered to for responsible management of refrigerants. Know the applicable laws and follow them.

## **WARNING** **Contains Refrigerant!**

**System contains oil and refrigerant under high pressure. Recover refrigerant to relieve pressure before opening the system. See unit nameplate for refrigerant type. Do not use non-approved refrigerants, refrigerant substitutes, or refrigerant additives.**

**Failure to follow proper procedures or the use of non-approved refrigerants, refrigerant substitutes, or refrigerant additives could result in death or serious injury or equipment damage.**

**⚠️ WARNING****Personal Protective Equipment (PPE) Required!**

Installing/servicing this unit could result in exposure to electrical, mechanical and chemical hazards.

- Before installing/servicing this unit, technicians **MUST** put on all Personal Protective Equipment (PPE) recommended for the work being undertaken. **ALWAYS** refer to appropriate MSDS sheets and OSHA guidelines for proper PPE.
- When working with or around hazardous chemicals, **ALWAYS** refer to the appropriate MSDS sheets and OSHA guidelines for information on allowable personal exposure levels, proper respiratory protection and handling recommendations.
- If there is a risk of arc or flash, technicians **MUST** put on all necessary Personal Protective Equipment (PPE) in accordance with NFPA70E for arc/flash protection **PRIOR** to servicing the unit.

Failure to follow recommendations could result in death or serious injury.

**Trademarks**

CenTraVac, DynaView, EarthWise, TechView, Trane, and the Trane logo are trademarks of Trane in the United States and other countries.



# Table of Contents

|  |    |
|--|----|
| Specifications .....                                 | 6  |
| General Information .....                            | 7  |
| Purge Nameplate .....                                | 7  |
| Purge Model Number .....                             | 8  |
| Model Number Descriptions .....                      | 8  |
| Purge System Overview .....                          | 9  |
| Introduction .....                                   | 9  |
| Purge Subsystems .....                               | 11 |
| Refrigeration Circuit .....                          | 13 |
| Purge Tank .....                                     | 14 |
| Pumpout System .....                                 | 14 |
| Carbon Tank and Regeneration System .....            | 14 |
| Purge Control System .....                           | 15 |
| EarthWise Purge Operating Principles .....           | 16 |
| General .....  | 16 |
| Typical Refrigeration Circuit Operating Cycle .....  | 16 |
| Operating Modes .....                                | 17 |
| Adaptive Mode Procedure—Chiller Compressor On .....  | 18 |
| Adaptive Mode Procedure—Chiller Compressor Off ..... | 20 |
| Air Removal .....                                    | 22 |
| Non-Condensable Pumpout Algorithm .....              | 23 |
| Non-Condensable Removal .....                        | 24 |
| Non-Condensable Pumpout Procedure .....              | 24 |
| Carbon Tank Regeneration .....                       | 26 |
| Carbon Tank Regeneration Procedure .....             | 27 |
| Operator Interface .....                             | 29 |
| Introduction .....                                   | 29 |
| CH530 DynaView Operator Interface .....              | 29 |
| Main .....   | 30 |
| Reports .....  | 32 |
| Settings .....                                       | 34 |
| Viewing Diagnostics .....                            | 37 |
| Maintenance .....                                    | 38 |
| Periodic Maintenance .....                           | 38 |
| Filter-Drier Assembly Replacement .....              | 39 |
| Moisture Monitoring and Removal .....                | 40 |
| Moisture Indicating Sight Glass .....                | 40 |
| Purge Operation After Major Chiller Repairs .....    | 40 |
| Troubleshooting Using Purge Diagnostics .....        | 42 |
| Troubleshooting Procedures .....                     | 42 |

---

|   |    |
|---|----|
| Refrigeration System Diagnostic Procedure ..... | 45 |
| Charge Level .....                              | 46 |
| Expansion Valve .....                           | 47 |
| Chiller Vapor/Liquid .....                      | 47 |
| Using The Service Functions .....               | 47 |
| Electrical .....                                | 49 |
| Purge Control System .....                      | 49 |



# Specifications

## Electrical Power Requirements

115 Vac, 60 Hz, 1-Phase 10.3 amps

110 Vac, 50 Hz, 1-Phase 10.3 amps

**Note:** Voltage range is +10%, -15%

## Purge Compressor Motor RLA

8

## Total Unit Amps

10.3

## Minimum Circuit Ampacity

12.3

## Carbon Tank Heater Watts

175

Alarm Relay Output Rating

120 Vac, 1/3 hp, 7.2 FLA

## Operating Environment

34°F (1.1°C) to 110°F (43.3°C)

5% to 95% relative humidity

non-condensing

## Storage Environment

-40°F (-40°C) to 150°F (65.5°C)

5% to 95% relative humidity

non-condensing

## Mounting

Direct-mounted on condenser shell above the liquid level of highest condenser

## Dimensions (approx.)

25-3/4" high x 27-1/2" wide x 21-3/4" deep, with filter-drier

## Weight

140 pounds with filter-drier

## Condensing Unit Refrigerant Charge

0.60 lb of R-404A

# General Information

## Purge Nameplate

The purge nameplate is located on the purge control panel. Always provide the purge model number, serial number or order number, and product description information from the purge nameplate when making inquiries or ordering parts or literature for the purge unit. Refer to [Figure 1](#) for an example of a typical nameplate from a retrofit purge. The nameplate of a factory installed purge may be slightly different.

**Figure 1. Typical Purge Nameplate**

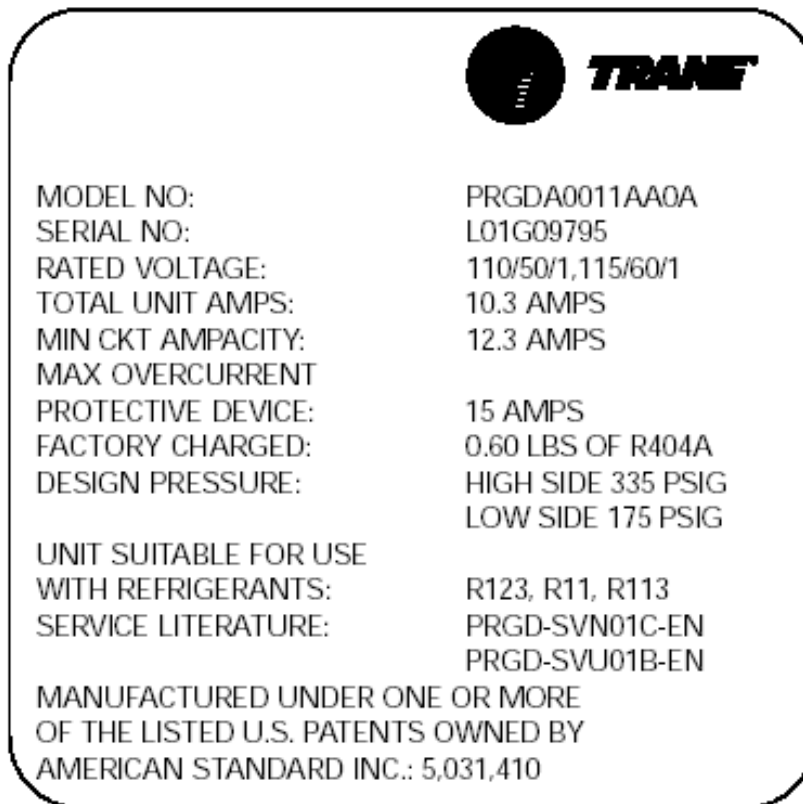



# Model Number Descriptions

## Purge Model Number

The operating components and options for any Trane® EarthWise Purge are assigned a multiple character alphanumeric model number that precisely identifies each unit. This service model number is then marked on the unit nameplate.

An explanation of the identification code that is used within this purge model number is shown here.

Use of the service model number will enable the owner/operator, installing contractors, and service technicians to define the operation, components, and options for any specific unit. The purge service model number is of utmost importance when identifying purge parts or when requesting technical assistance.

## Sample

**PRGDA011AA00**

### Digit 1, 2, 3 – Unit Type

PRG= Purge

### Digit 4 – Development Sequence

- A = First Generation
- B = Second Generation
- C = Third Generation
- D = Fourth Generation

### Digit 5 – Enclosure Type

- A = Standard
- B = NEMA 4
- C = NEMA 4 with Hersite Condensing Unit
- S = Special

### Digit 6 – Control Options

- 1 = Power Supply
- 2 = Condenser Pressure Cutout—Standard
- 3 = Condenser Pressure Cutout—ASME

### Digit 7 – Control Interface

- 0 = Chiller Interface
- 1 = Purge Interface

### Digit 8 – Frequency

- 1 = 60 Hz
- 2 = 50 Hz

### Digit 9 – Vacuum Pump

- A = Standard Vacuum Pump
- B = High Vacuum Pump

### Digit 10, 11 – Design Sequence

- A0 = Original

### Digit 12 – Special Options

- 0 = None
- S = Special

# Purge System Overview

## Introduction

A purge system is required on all low pressure centrifugal water chillers to remove air, moisture, and other non-condensables that may leak into the machine. The EarthWise Purge system is designed to accomplish this task efficiently.

Trane® centrifugal chillers utilizing low pressure refrigerants CFC-11, CFC-113, and HCFC-123 operate with areas of the chiller at less than atmospheric pressure. This is in contrast to the high pressure refrigerants CFC-12 and HCFC-22, which are used in refrigeration systems which operate above atmospheric pressure. [Figure 2](#) compares the pressure/temperature relationship between low and high pressure refrigerants and indicates the temperatures at which chiller system pressures are negative with respect to atmosphere.

**Figure 2. Temperature/Pressure relationship for common refrigerants**

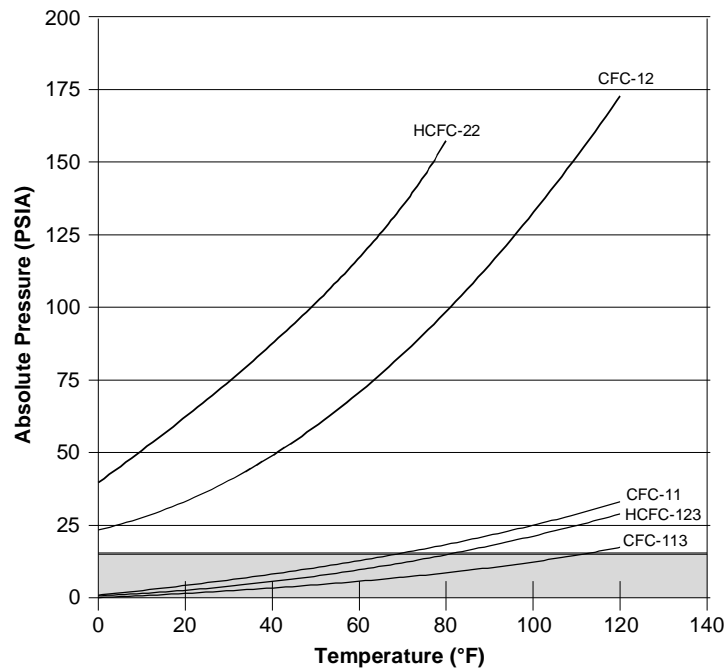

[Figure 3, p. 10](#) illustrates the low pressure areas of a typical Trane® CenTraVac™ (model CVHF shown) when the unit is running under normal conditions. Air may leak into the machine through these low pressure areas. Once it enters the chiller, the air will accumulate in the condenser during machine operation. If it is not removed, air in the condenser reduces its ability to condense refrigerant and results in an increased condenser pressure. The increased condenser pressure results in a lower chiller efficiency and capacity.

**Figure 3. Low pressure areas of operating unit**

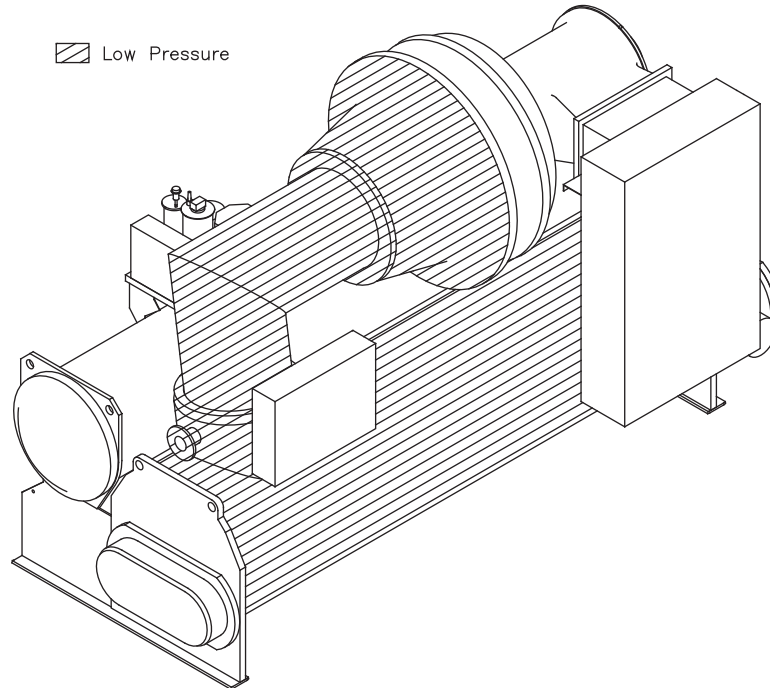

The EarthWise Purge is a device mounted externally to the chiller. It consists basically of a tank, inlet and outlet valves, and a refrigeration system. The evaporator of the refrigeration system is located in the purge tank and is called the purge evaporator. The purge tank is connected to the chiller condenser by supply and return lines through which refrigerant may freely flow. The purge evaporator coil presents a cold condensing surface to the chiller refrigerant entering the tank. When the purge refrigeration circuit is running, refrigerant from the chiller condenser is attracted to the cold surface of the purge evaporator in the purge tank. When the gaseous refrigerant contacts the cool surface of the purge evaporator coil it condenses into a liquid, leaving a partial vacuum behind. More refrigerant vapor from the chiller condenser then migrates to the purge tank to fill this vacuum. The liquid refrigerant condensed in the purge tank returns to the chiller condenser via the liquid return line. Any non-condensables in the vapor from the chiller condenser do not condense in the purge tank and are left behind to fill more and more space in the purge tank. Increasing quantities of non-condensables accumulating in the purge tank will reduce the heat transfer efficiency of the purge evaporator coil, and the purge compressor suction temperature will decrease. The purge compressor suction temperature is monitored by the unit controls, which will activate the pumpout cycle to remove the accumulated non-condensables from the purge tank. When enough of the non-condensables have been removed the increasing purge compressor suction temperature will terminate the pumpout cycle.

The EarthWise Purge will track the pumpout activity for a given machine as an indicator of air leakage into the chiller. This feature is provided to inform the machine operator of purge activity. The ability to monitor purge operation is an important feature of the EarthWise Purge unit.

**Important:** *“Normal” average pumpout time for a PRGD model purge installed on a CFC-11 or HCFC-123 chiller will be approximately 7 minutes per day for a one week period. This value, however, will vary widely depending on chiller size, operating conditions, and operating schedule. The purge pumpout activity for each individual chiller should be carefully monitored for an appropriate period of time (one week or more) in order to establish a baseline value for a DAILY PUMPOUT LIMIT that is appropriate for that individual installation. The purge DAILY PUMPOUT LIMIT should be set high enough*

*to avoid nuisance trips, but low enough to trigger an alarm diagnostic should the pumpout rate suddenly increase. Carefully review [“Troubleshooting Using Purge Diagnostics,” p. 42](#) and the chiller purge history before a decision is made to shut down the chiller for leak testing and repair.*

## Purge Subsystems

From a functional standpoint, the PRGD purge system can be divided into subsystems of components.

- Refrigeration Circuit
- Purge Tank
- Pumpout System
- Carbon Tank and Regeneration System
- Purge Control System

These subsystems and their component parts are shown in [Figure 4, p. 12](#) and discussed in the following material.

**Note:** *Retrofit purge illustrated. Factory mounted purge utilizes the UCP DynaView™ operator interface and chiller control system sensors for purge liquid temperatures.*

# Purge System Overview

**Figure 4. Typical EarthWise Purge component list**

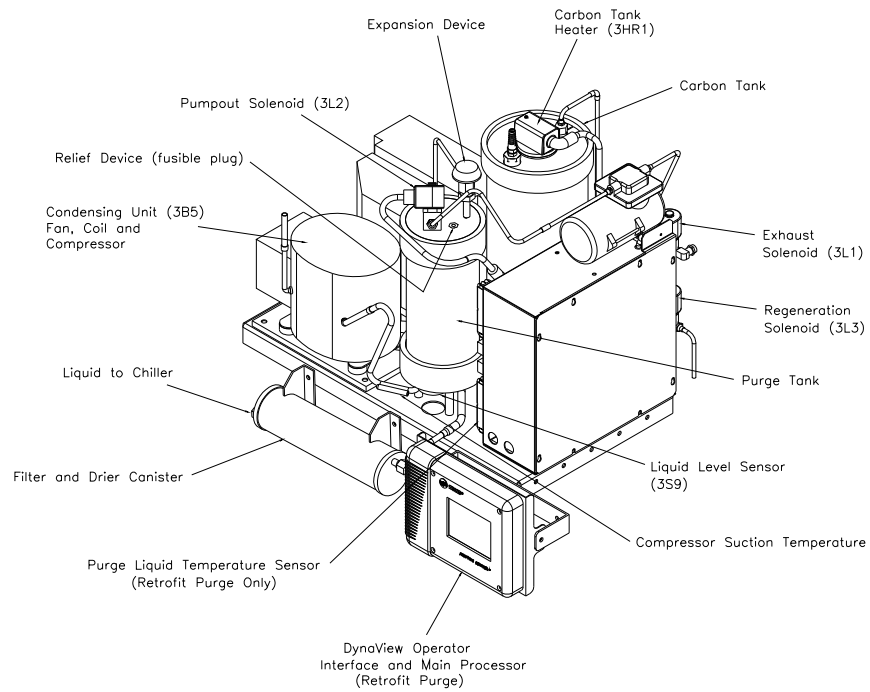
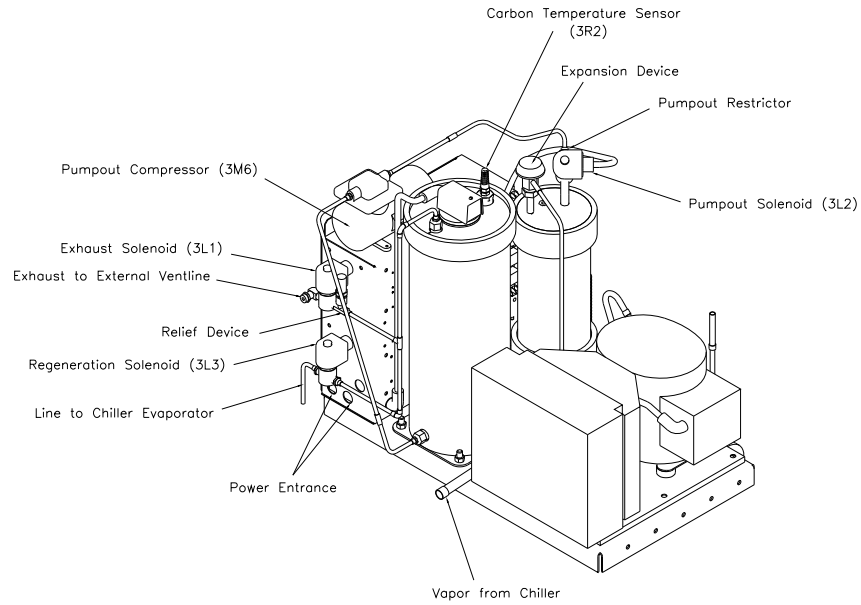

### Refrigeration Circuit

The portion of the purge that removes heat from the purge tank and transfers it to the atmosphere is the refrigeration circuit. This is an enclosed refrigerant circuit consisting of an air-cooled 1/4 hp condensing unit (compressor, fan, and condensing coil), an expansion device, and an evaporator coil inside the purge tank. The single purpose of the refrigeration circuit is to provide cooling for the purge evaporator coil inside the purge tank. The cool evaporator coil causes refrigerant vapor in the purge tank to condense on the evaporator coil.

The coil in the purge tank acts as an evaporator from the standpoint of the refrigeration circuit, and as a condenser from the standpoint of the chiller's refrigerant.

The air-cooled condensing unit of the purge operates effectively in the operating range shown in Figure 5.

### CAUTION Hot Surfaces!

**Surface temperatures may exceed 300°F (150°C) on condensing unit and carbon tank. Contact of bare skin on hot surfaces may result in minor to severe burns.**

**Note:** Because the EarthWise Purge utilizes an air-cooled condenser, it is operable whether the chiller is running or not. No additional cooling source is required.

**Important:** No water connection are required for the EarthWise Purge.

**Figure 5. EarthWise Purge operating limits**

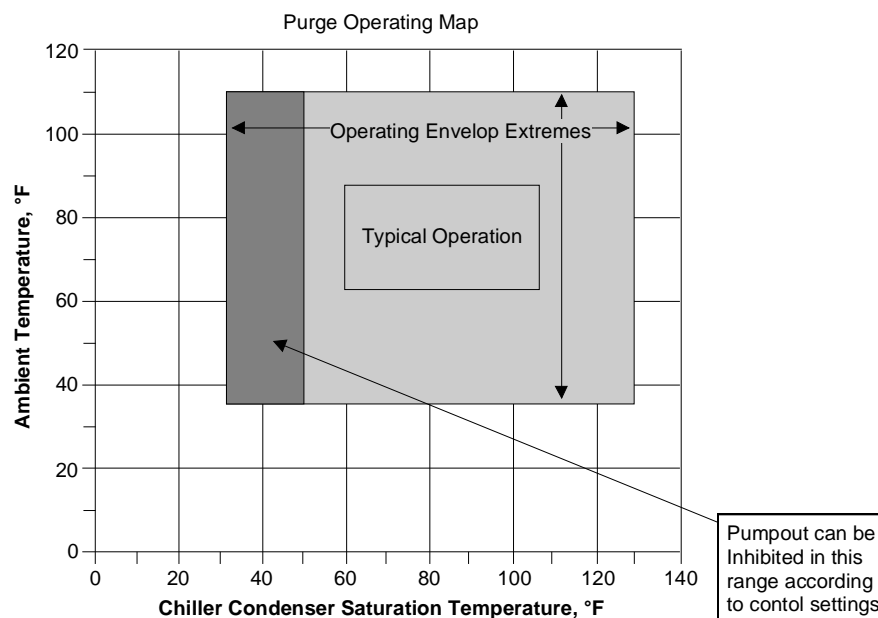

For purges equipped with standard pump-out compressors, operation at low Chiller Condenser Saturation temperatures may result in a system vacuum greater than the pump-out compressor can overcome. If the chiller will experience low condensing temperatures, then the operation of the purge pump-out compressor can be inhibited by the unit controls.

If purge operation at low condensing temperatures and pressures is a requirement of the application, then a "High Vacuum Pump" option is available that will provide a two stage pump-out compressor. The "High Vacuum Pump" option allows purge operation to saturation temperatures as low as 34°F (2.8°C). Typical applications that may require the "High Vacuum

## Purge System Overview

---

Pump” option would include free cooling installations, series chiller installations, ice systems having brine flowing through idle chillers, chillers installed outdoors or in unconditioned spaces, or any application that may cause very low condenser water temperatures.

### Purge Tank

The purge tank consists of the purge evaporator coil, connections for the refrigerant gas from the chiller condenser and a liquid return line to the chiller condenser, and a protective float switch. In the purge tank any non-condensables are separated from the refrigerant vapor and are collected until they can be removed by the pumpout system.

The float switch installed in the bottom of the purge tank is used to provide an indication of excessive liquid accumulation in the purge tank. If the normally closed float switch is open for more than 20 minutes the purge controls will turn off the refrigeration circuit and generate a non-latching diagnostic. If after the 20 minutes the float switch has re-closed, the purge controls will restart the refrigeration circuit.

If the float switch remains open for more than 20 minutes, or if the float switch/liquid level restart cycle has occurred more than four times in four hours, a latching diagnostic will be generated and the purge will not operate until it is reset. If a float switch diagnostic occurs check the purge lines for any type of restriction (trapped liquid, closed valves, etc.) and ensure the filter drier on the liquid return line is in good condition.

The purge liquid return line from the purge tank to the chiller condenser includes a filter drier assembly and a moisture indicating sight glass.

A purge tank pressure relief device (fusible plug) is mounted on the purge tank. It protects against over pressurization of the purge tank and is a UL required device.

The plug material will fuse at 168°F (75.6°C) which equates to approximately 45 psig for refrigerant R-123.

### Pumpout System

The pumpout system consists of a small pumpout compressor and two solenoids, a pumpout solenoid valve and an exhaust solenoid valve. When the purge control system detects the presence of non-condensables in the purge tank, the two solenoids are opened and the pumpout compressor is turned on. The purge control system will cycle the solenoids and compressor on and off as needed to achieve an efficient and fast removal of non-condensables.

### Carbon Tank and Regeneration System

The discharge of the small pumpout compressor is piped through the carbon tank. The special carbon in the tank effectively scrubs and collects refrigerant molecules from the non-condensable gas before the gas passes through the Exhaust Solenoid Valve and out to the chiller vent line. A 175-watt resistive heater is mounted inside the carbon tank and is used to periodically “regenerate” the carbon bed and drive any collected refrigerant vapor back into the chiller.

A pressure relief valve rated at 150 psi is mounted on the line leaving the carbon tank. It protects against over-pressurization of the carbon tank and is a UL required device.

A temperature sensor is installed through the top of the carbon tank shell in order to allow the controls to monitor the temperature of the carbon bed. It is used to control the regeneration cycle and protect against overheating, if the limit temperature is reached the system will be shutdown and a diagnostic generated.

#### **CAUTION** **Hot Surfaces!**

**Surface temperatures may exceed 300°F (150°C) on condensing unit and carbon tank. Contact of bare skin on hot surfaces may result in minor to severe burns.**

** WARNING****Contains Refrigerant!**

System contains oil and refrigerant under high pressure. Recover refrigerant to relieve pressure before opening the system. See unit nameplate for refrigerant type. Do not use non-approved refrigerants, refrigerant substitutes, or refrigerant additives.

Failure to follow proper procedures or the use of non-approved refrigerants, refrigerant substitutes, or refrigerant additives could result in death or serious injury or equipment damage.

**Purge Control System**

The EarthWise Purge uses the Trane<sup>®</sup> CH530 control system. The system architecture distributes its electronics to the lowest possible level to maximize the ease of maintenance and troubleshooting and minimize the cost of any repairs.

For information regarding the purge controls refer to the electrical section of this manual.

# EarthWise Purge Operating Principles

## General

The purge is active when the purge condensing unit is powered. The condensing unit is used to condense refrigerant vapor (from the chiller) the purge tank. The condensing unit lowers the temperature/pressure in the purge tank, drawing the vapor from the chiller's condenser.

The vapor carries non-condensables and moisture with it into the purge tank. The vapor enters the purge tank through a 5/8"-line connected at the bottom of the purge tank. Once inside the tank, refrigerant vapor will condense and fall to the bottom of the tank where a liquid return line will carry the condensed refrigerant through a filter-drier and back to the chiller condenser. Non-condensables will be left behind and will accumulate in the purge tank (see [Figure 6](#)).

Figure 6.

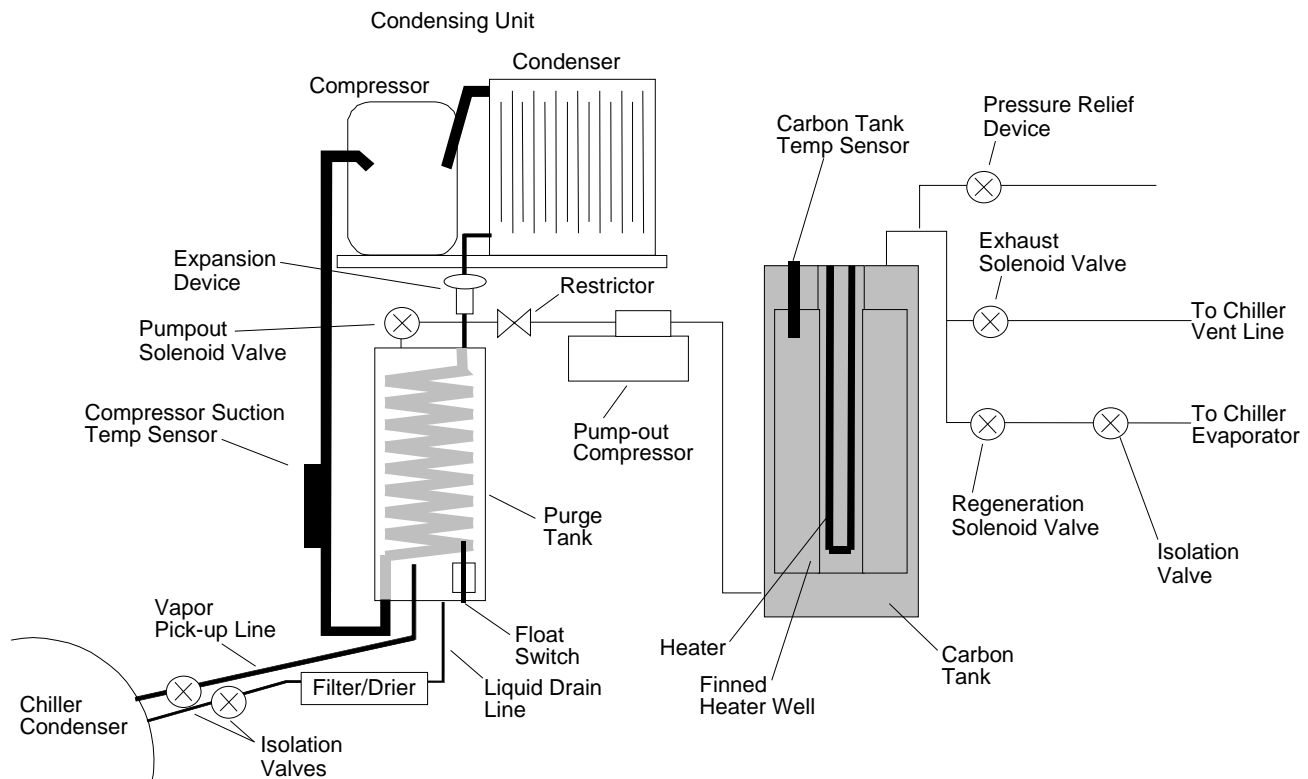

## Typical Refrigeration Circuit Operating Cycle

Figure 7, p. 17 illustrates the refrigeration cycle of the EarthWise Purge at typical operating conditions of 70°F (21.1°C) ambient and 100°F (37.8°C) condensing temperature.

- Point 1 = -16°F (-26.7°C)
- Point 2 = Greater than 60°F (15.5°C) when few non-condensables are present
- Point 3 = 150°F (65.5°C)
- Point 4 = 85°F (29.4°C)
- Point 5 = 75°F (23.9°C)

Figure 7. EarthWise Purge refrigerant circuit schematic

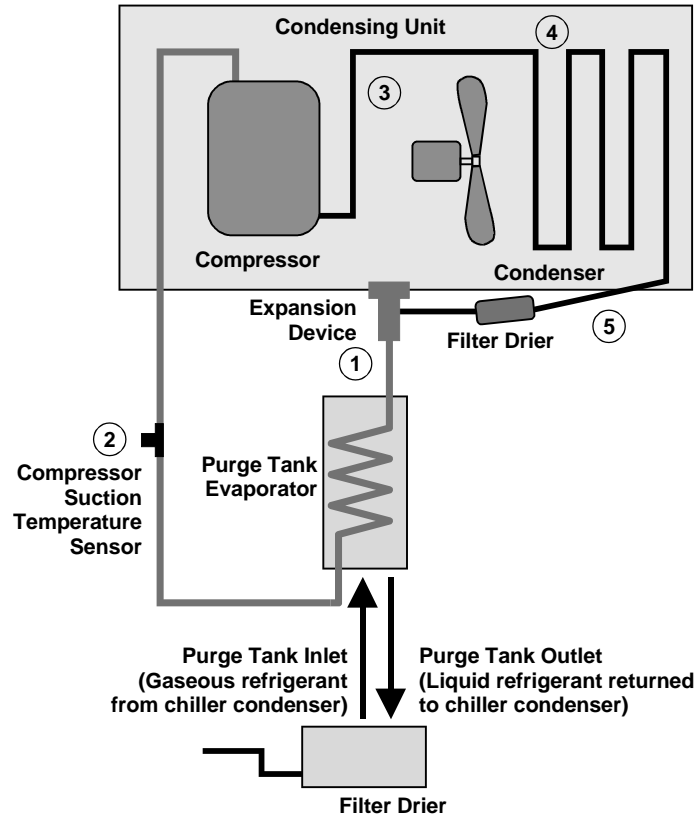

The purge condensing unit compressor suction temperature (Point 2) will vary with the amount of air collected in the purge tank. When the amount of non-condensables collected in the purge tank begins to limit the available condensing surface in the tank, the condensing unit compressor suction temperature (Point 2) will begin to fall. The purge control will initiate a pumpout cycle when the suction temperature (Point 2) reaches the pumpout initiate setpoint that is calculated within the purge control. During the pumpout cycle the small pumpout compressor pulls any non-condensables from the purge tank and discharges them through the carbon tank. As the non-condensables are removed from the purge tank the condensing unit compressor suction temperature (Point 2) will increase. The purge controls monitor the compressor suction temperature (Point 2) and will cycle or stop the pumpout depending on the temperature that is present.

### Operating Modes

The operator may establish the desired operating mode of the EarthWise Purge via the DynaView operator interface. Touch the Settings file tab of the touch-screen display, then press the Purge line. The purge Operating Mode line can then be selected and the following choices will appear:

#### Stop

If **Stop** is selected, the purge condensing unit will not run.

#### On

If **On** is selected, the purge condensing unit runs continuously regardless of the chillers operational status.

## EarthWise Purge Operating Principles

---

### Auto

If **Auto** is selected, the purge condensing unit runs when the chillers main compressor is in operation.

### Adaptive

If **Adaptive** is selected, the purge condensing unit operation is totally dependent on past purge activity.

The objectives of operating the unit in the Adaptive mode are:

- Operating the purge refrigeration circuit to effectively accumulate non-condensables with or without the chiller running.
- Provide information to the operator as to whether leakage is on the high-pressure or low-pressure side of the chiller.
- Decrease energy usage by running the purge refrigeration circuit only when needed to remove non-condensables, rather than running continuously.

The adaptive mode requires historical operating data in order to make decisions as to how to best operate the purge refrigeration circuit in the future. To accumulate this data, at the first start-up of the chiller the adaptive control will operate the purge refrigeration circuit continuously for 168 hours (7 days). The chiller compressor may or may not be running during this period.

Following the initial data collection period, the adaptive mode will customize the purge refrigeration circuit operation during two distinct chiller operating conditions, chiller compressor on and chiller compressor off.

## Adaptive Mode Procedure—Chiller Compressor On

The purge refrigeration circuit will be started when the chiller compressor starts. The purge refrigeration circuit will continue to run until 60 consecutive minutes of running occur without any pumpout of non-condensables.

The purge control will then look at two parameters it has been tracking:

- The daily pumpout time with the chiller on, over the last 24 hours.

| <b>Pumpout Time, with Chiller ON (over the last 24 hours, or the daily average over the last 7 days, whichever is greater)</b> | <b>Purge Off Cycle Duration</b> |
|--|---------------------------------|
| Pumpout time $\leq$ 1 minute   | 4 hours                         |
| 1 minute $<$ Pumpout time $\leq$ 3 minutes   | 3 hours                         |
| 3 minutes $<$ Pumpout time $\leq$ 5 minutes  | 2 hours                         |
| 5 minutes $<$ Pumpout time $\leq$ 8 minutes  | 1 hour                          |
| Pumpout time $>$ 8 minutes   | No Off Cycle                    |

The average daily pumpout time with the chiller on, over the last 7 days.

The unit control will select whichever value is greater, and label it as Pumpout Time. The purge will then be shut down for a period of time as determined in the table below.

During the purge refrigeration circuit off cycle the time remaining will be displayed as the “Time Until Next Purge Run” in the purge report of the DynaView (see [Figure 8, p. 19](#)).

If the compressor is turned off during the purge refrigeration circuit off cycle, the purge will transfer to “Adaptive Mode Procedure – Chiller Compressor Off.” For your reference, a flow chart is included (see [Figure 9, p. 21](#)).

**Figure 8. Adaptive chiller ON flow chart**

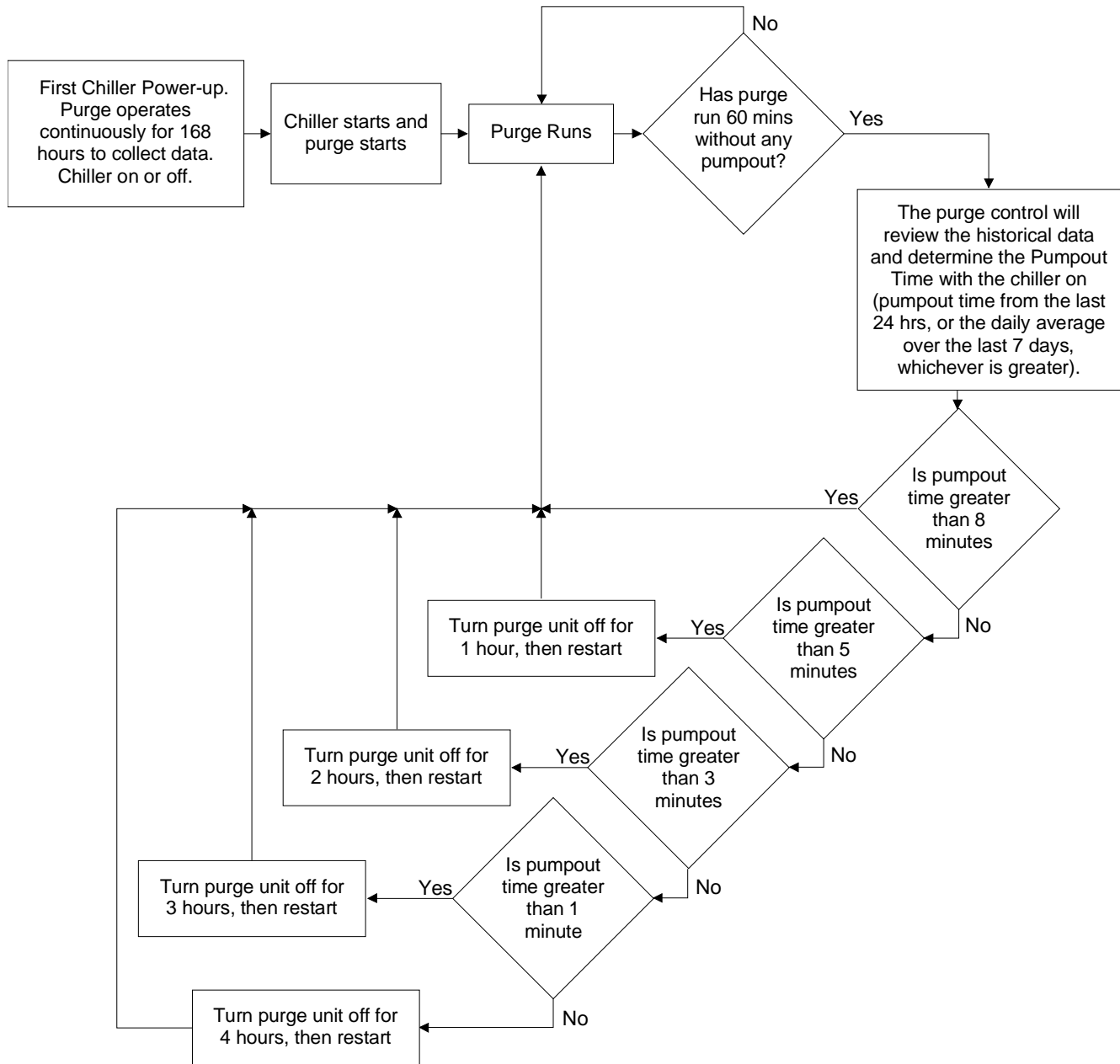

## EarthWise Purge Operating Principles

---

### Adaptive Mode Procedure—Chiller Compressor Off

When the chiller compressor is turned off, the purge refrigeration circuit off cycle will be determined by the purge control. The control will look at two parameters it has been tracking:

- The daily pumpout time with the chiller on OR off, over the last 24 hours.
- The average daily pumpout time with the chiller on OR off, over the last 7 days.

The purge control will select whichever value is greater, and label it as Pumpout Time. The purge will then be shut down for a period of time as determined in the following table.

| <b>Pumpout Time, with Chiller ON or OFF (Daily pumpout over the last 24 hours, or the daily average over the last 7 days, whichever is greater)</b> | <b>Purge Off Cycle Duration</b> |
|---|---------------------------------|
| Pumpout time $\leq$ 1 minute  | 3 days                          |
| 1 minute < Pumpout time $\leq$ 3 minutes  | 2 days                          |
| 3 minutes < Pumpout time $\leq$ 5 minutes   | 1 day                           |
| Pumpout time > 5 minutes  | 6 hours                         |

During the purge refrigeration circuit off cycle the time remaining will be displayed as the “Time Until Next Purge Run” in the purge report of the DynaView.

If the controls determine it is necessary to run the purge while the chiller compressor is off, the purge will be started and run until 60 consecutive minutes have passed without any pumpout of non-condensables (see [Figure 9, p. 21](#)).

If the chiller compressor is started before the purge off cycle has elapsed, the purge will start and will transfer to “Adaptive Mode Procedure – Chiller Compressor On.” For your reference a flow chart is included (see [Figure 8, p. 19](#)).

**Figure 9. Adaptive chiller OFF flow chart**

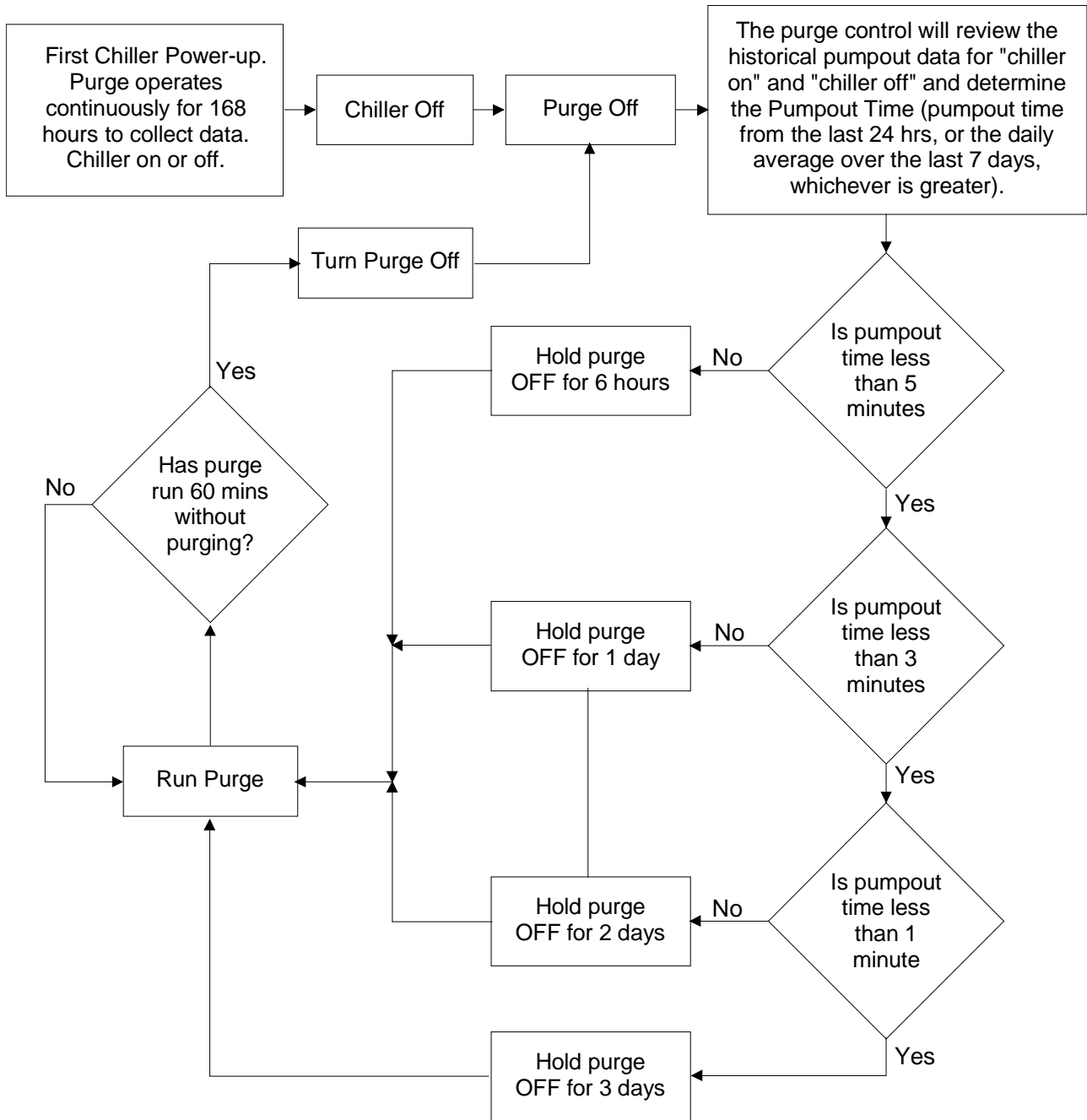

### Air Removal

Figure 10, p. 23 illustrates the air/non-condensables removal cycle as air accumulates in the purge tank. When there is no air in the purge tank, the refrigerant returning to the purge condensing unit compressor suction has a high superheat, because of the heat removed from the condensing chiller refrigerant vapor in the purge tank. As air accumulates in the purge tank, it will displace the chiller refrigerant vapor and decrease the amount of coil surface that is exposed to the vapor. Less heat will be removed from the chiller refrigerant vapor and the available superheat at the purge condensing unit suction will fall.

When the condensing unit suction temperature falls far enough to reach the Pumpout Initiate Setpoint, the purge control will activate the solenoids and the pumpout compressor to remove the accumulated non-condensables. As air is removed from the purge tank, the inside coil is once again exposed to chiller refrigerant vapor. Increased amounts of heat will be available from the chiller refrigerant vapor that is now able to reach and condense on the coil, and the purge compressor suction temperature will rise. The purge controls monitor the compressor suction temperature and will cycle or stop the pumpout depending on the temperature that is present.

**Figure 10. Purge tank air vs. condensing coil superheat**

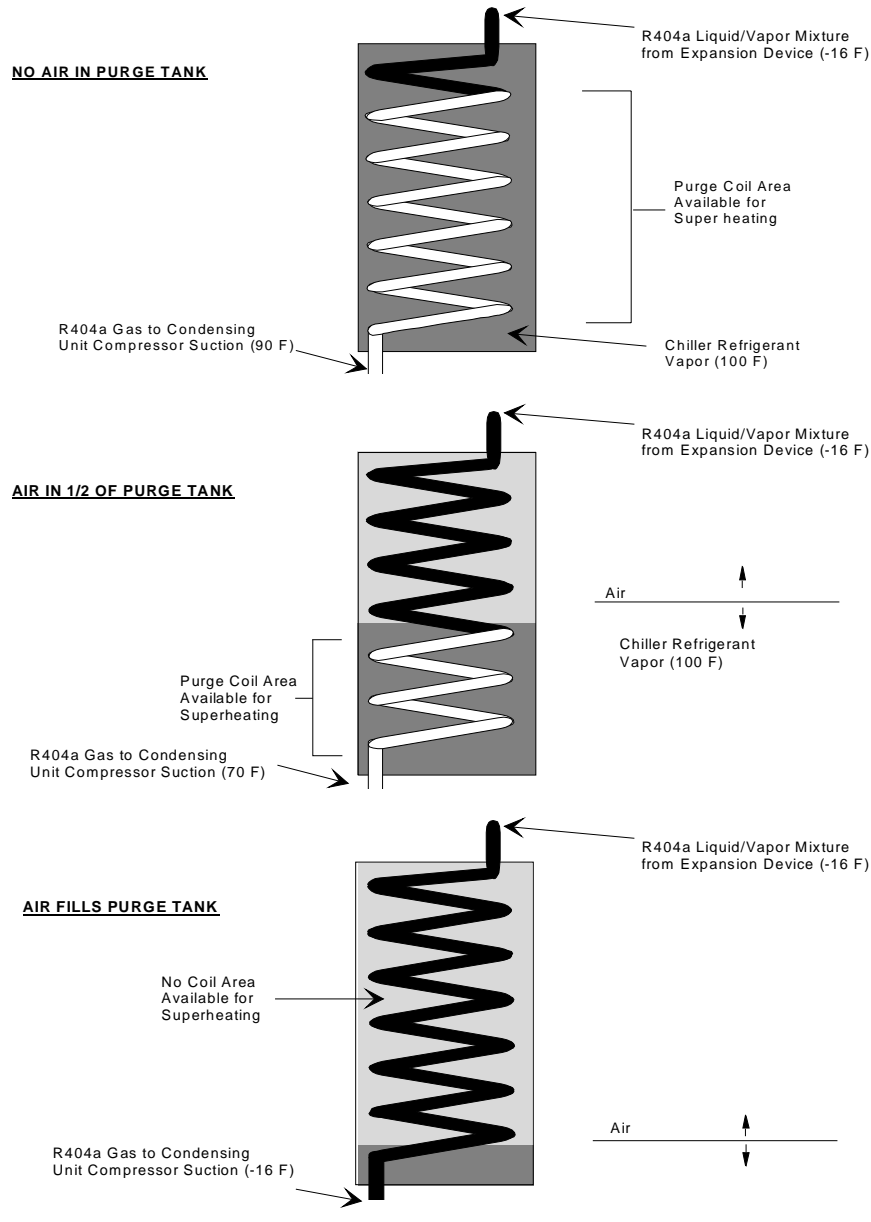

## Non-Condensable Pumpout Algorithm

The non-condensable pumpout algorithm will be used to determine when to initiate, control and terminate a pumpout cycle to remove non-condensables from the purge tank. The purge compressor suction temperature sensor will serve as the feedback to this algorithm. The compressor suction temperature pumpout initiate and pumpout terminate setpoints are calculated by the purge control and are a function of the purge liquid temperature.

### Non-Condensable Removal

Purge refrigeration circuit refrigerant (R-404A) is metered into the purge tank coil via a constant pressure regulating expansion valve. The valve automatically controls the purge suction pressure at a constant value of 34 psia (234 kPa). Therefore refrigerant is metered into the coil as a two-phase refrigerant mixture at a constant saturation temperature of approximately -16°F (-8.9°C). The cold coil creates a low vapor pressure near the coil outside surface, which draws refrigerant from the chiller condenser into the purge tank and to the surface of the coil. Once near the coil surface the chiller refrigerant condenses into a liquid consequently requiring much less volume. Additional refrigerant is drawn in to fill the void and in-turn condenses. This mechanism is known as a thermal siphon. As the chiller refrigerant condenses, heat is transferred into the purge coil through the latent heat of condensation. The compressor suction temperature sensor monitors this heat transfer.

Air and other gases carried with the chiller refrigerant vapor do not condense on the coil. Instead they accumulate in the purge tank, effectively acting to insulate and inhibit the flow of refrigerant to the cold coil surface. The thermal siphon rate is reduced and therefore the amount of heat transfer is reduced. This results in a corresponding reduction in the temperature of the purge refrigerant exiting the coil. The compressor suction temperature sensor monitors this temperature. When sufficient non-condensables have accumulated in the purge tank to decrease the compressor suction temperature below the pumpout initiate setpoint a pumpout cycle is begun. The cycle will be terminated when the compressor suction temperature sensor increases above the pumpout terminate setpoint. The calculations for the pumpout setpoints are:

Pumpout Initiate Setpoint, °F = purge liquid temp (°F) - 50°F or 0°F (whichever is higher).

Pumpout Terminate Setpoint, °F = purge liquid temp (°F) - 40°F or 5°F (whichever is higher)

The purge liquid temperature sensor on a factory installed purge is the chiller's saturated condenser temp sensor when the chiller is running, and it is the chiller's saturated evaporator temperature sensor when the chiller is off.

The purge liquid temperature sensor on a field-installed retrofit purge is mounted on the purge liquid drain line.

### Non-Condensable Pumpout Procedure

A non-condensable pumpout cycle may only be initiated as described below if 1) a carbon regeneration cycle is NOT in process, and 2) the refrigeration circuit is on.

If at any time, except as described above, the purge compressor suction temperature drops below the pumpout initiate setpoint, the following pumpout procedure will be initiated by the controls:

1. The controls will start the pumpout compressor and open the exhaust solenoid valve.
2. After 5 seconds, the pumpout solenoid valve will be opened and pulsed at 20 seconds on and 20 seconds off. If after 2 cycles the suction temperature has not exceeded the pumpout terminate setpoint, the control will leave the pumpout solenoid valve open continuously.
3. If the pumpout compressor has run for more than 10 consecutive minutes, the pumpout initiate and pumpout terminate setpoints will be recalculated as described above.
4. The purge controls will continue to operate the pumpout solenoid valve and calculate setpoints as described above until the purge compressor suction temperature rises above the pumpout terminate setpoint. At this point, the controls will close the pumpout solenoid valve and turn off the pumpout compressor and exhaust solenoid valve. Typical pumpout cycles are shown in [Figure 11, p. 25](#) and [Figure 12, p. 25](#).

Figure 11. Non-condensable pumpout cycle, large quantity of air

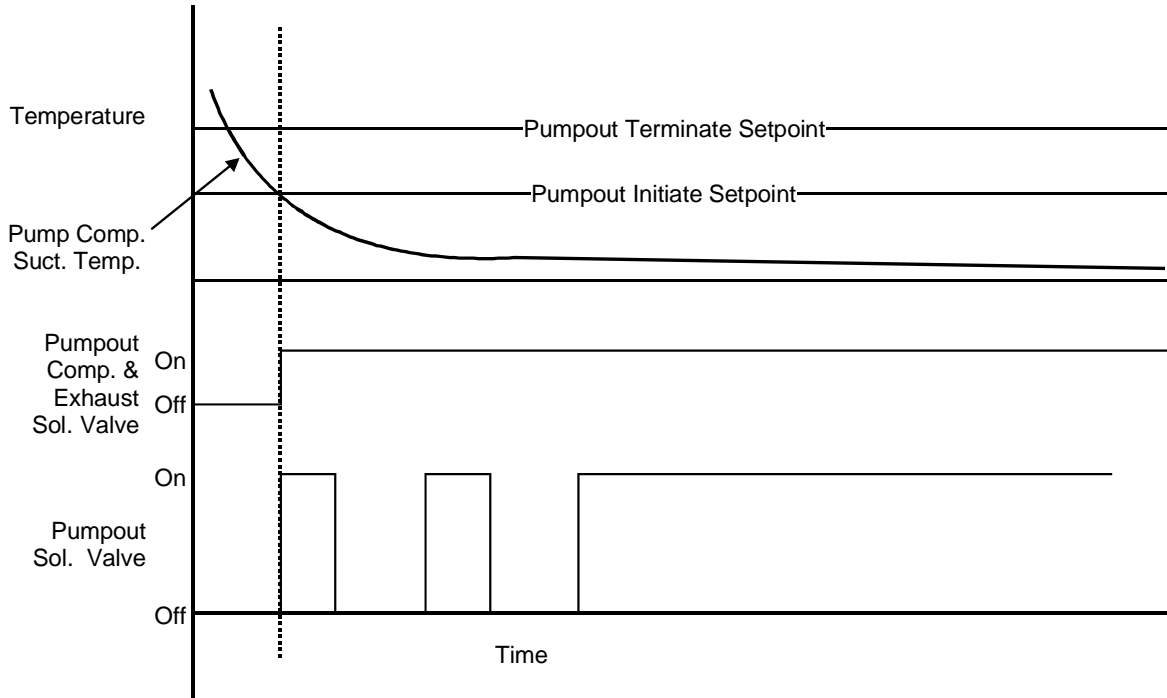
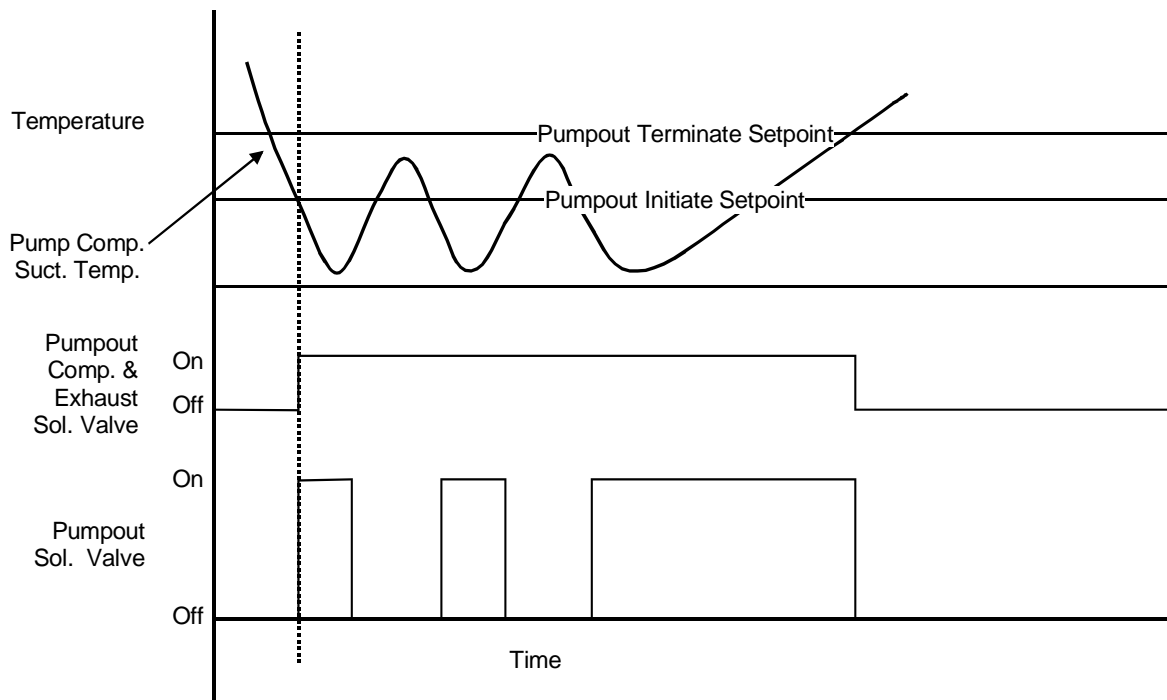

Figure 12. Non-condensable pumpout cycle, small quantity of air



## EarthWise Purge Operating Principles

---

### Carbon Tank Regeneration

The function of the carbon tank is to absorb refrigerant molecules that may be entrained in the discharge of non-condensables. In order to maintain its effectiveness, the carbon tank will periodically be regenerated.

#### Carbon regeneration algorithm

The carbon regeneration algorithm is the program used to determine when to initiate, control and terminate a carbon regeneration cycle. The carbon bed temperature sensor serves as the feedback to this algorithm. In addition, a pumpout accumulation timer within the unit controls is used to indicate the remaining carbon capacity in the carbon tank. Carbon capacity is the capacity of the carbon to adsorb refrigerant while maintaining acceptable levels of refrigerant emission through the chiller vent line. 100 percent capacity means the carbon bed has the maximum capacity to adsorb refrigerant and maintain acceptable emission levels; 0 percent capacity means the carbon bed has inadequate capacity to adsorb refrigerant and still maintain acceptable emission levels.

The main objectives of the Carbon Regeneration Algorithm are:

1. Minimize the amount of refrigerant contained in the carbon by performing a periodic regeneration.
2. Regenerate to maintain low emissions levels.
3. Minimize the regeneration time.
4. Regenerate only when the chiller is at a minimum level of purging activity.
5. Allow regeneration to occur with the chiller running or off. Regeneration is preferable when the chiller is running to ensure low carbon tank pressure but regeneration is also acceptable when the chiller is off.

The remaining amount of adsorption capacity within the carbon tank is directly proportional to the number of purge pumpout minutes that have accumulated, and is also a function of the chiller's refrigerant type. The following table sets the pumpout minutes accumulated between regeneration cycles at which time the carbon bed is saturated with refrigerant and must be regenerated:

| Chiller Refrigerant Type | Pumpout Minutes at 100% Carbon Capacity |
|--------------------------|---|
| R-123                    | 500                                     |
| R-11                     | 350                                     |
| R-113                    | 1000                                    |

Using the above table, the purge carbon tank on a R-123 equipped chiller is considered to be fully saturated after the purge has accumulated 500 minutes of pumpout time. Because the relationship between pumpout capacity and pumpout minutes is directly proportional, it can be described by the following equation within the regeneration algorithm:

$$\text{Remaining Carbon Capacity}\% = 100 - (\text{pumpout minutes since last regen} / \text{pumpout minutes at 100\% capacity}) * 100$$

For example, an R123 chiller that has accumulated 80 minutes of purge pumpout time since the last carbon tank regeneration would be estimated to have 84 percent of its carbon tank capacity remaining.

$$100 - (80/500) * 100 = 84\%$$

The purge controls may initiate a carbon tank regeneration cycle when the remaining carbon tank capacity is calculated to be less than 80 percent. However, the continued stable operation of the chiller is always more important than the regeneration of the carbon tank and the following rules apply:

1. If the Daily Pumpout Limit is disabled, a regeneration cycle may not be initiated, regardless of the value of the remaining carbon capacity.

Also, if the Daily Pumpout Limit is disabled during a regeneration cycle, the regeneration cycle must be terminated.

2. When the remaining carbon capacity is less than 80 percent, a regeneration cycle will be initiated at the next opportunity when the chiller is running (after the chiller has started and no pumpout minutes have accumulated for the previous 60 minutes).
3. If there is no opportunity to purge as indicated by Steps 1–2 and the remaining carbon capacity is less than 50 percent, a regeneration cycle will be initiated at the best opportunity when the chiller is shut down (and no pumpout minutes have accumulated for the previous 60 minutes).
4. If there is no opportunity to regenerate as indicated by Steps 1–3 and the carbon capacity drops below 0 percent then a regeneration cycle will be initiated.
5. Note that if at any time during the regeneration cycle, the chiller is running and shuts down or if the chiller is off and starts up, the regeneration cycle will be continued.

### Carbon Tank Regeneration Procedure

If the purge controls determine that Carbon Tank Regeneration is desired and is allowed, the purge controls will:

1. Disable the purge refrigeration circuit and the pumpout solenoid valve.
2. Open the regeneration solenoid valve and turn on the carbon tank heater.
3. Monitor the carbon temperature until it reaches the regeneration temperature setpoint and control within a  $\pm 10^{\circ}\text{F}$  ( $5.5^{\circ}\text{C}$ ) dead band for 15 minutes (this step should take approximately 3 hours).

| Refrigerant Type | Carbon Refrigeration Temperature Setpoint, °F |
|------------------|---|
| R-123            | 240   |
| R-11             | 210   |
| R-113            | 240   |

The controls will initiate a nonlatching diagnostic (Carbon Regeneration Temperature Too Low) if the carbon tank temperature does not increase more than  $25^{\circ}\text{F}$  ( $16.6^{\circ}\text{C}$ ) in the first two hours. This is intended to identify a failed heater or temperature sensor. This diagnostic will not permit automatic regenerations to occur, but a service technician can initiate a manual regeneration for testing purposes. All other purge algorithms will continue to function.

If the carbon tank temperature does not reach the minimum regeneration temperature setpoint within 4 hours, the controls will issue a non-latching diagnostic (Carbon Regeneration Temperature Setpoint Not Satisfied) and go to Step 4. This diagnostic is intended to identify a failing insulation system. If the carbon tank temperature exceeds 120 percent of the regeneration temperature setpoint the controls will issue a latching diagnostic (Carbon Regeneration Temperature Limit Exceeded). This is intended to identify a failed heater relay or temperature sensor. This diagnostic will disable the purge and open the exhaust solenoid valve.

4. Close the regeneration solenoid valve and turn off the heater.
5. Reset the calculated carbon capacity to 100 percent.
6. Turn the purge refrigeration circuit on and allow the carbon tank to cool for 4 hours or until the carbon temperature reaches  $100^{\circ}\text{F}$  ( $37.8^{\circ}\text{C}$ ), whichever comes first. The controls will initiate a latching diagnostic (Carbon Regeneration Temperature Limit Exceeded) if the carbon tank temperature does not decrease more than  $25^{\circ}\text{F}$  ( $13.9^{\circ}\text{C}$ ) in the first hour. This is intended to identify a failed heater relay or temperature sensor. This diagnostic will disable the purge and open the exhaust solenoid valve.

The small amount of non-condensable gas that may be resident in the carbon tank will be returned to the chiller during a regeneration cycle. Operating the refrigeration circuit during the

## EarthWise Purge Operating Principles

---

carbon cool-down cycle will allow time to accumulate this gas in the purge tank in readiness for the non-condensable pumpout controls to be reactivated following completion of the cool down cycle.

7. Open the exhaust solenoid for 5 minutes and then close.
8. Run the refrigeration circuit for 15 minutes and allow pumpouts during this time.

The complete regeneration cycle can take as long as seven hours to accomplish, though the average chiller will not have to regenerate very often. A typical regeneration cycle is depicted in [Figure 13](#).

**Figure 13. Typical Carbon regeneration cycle**

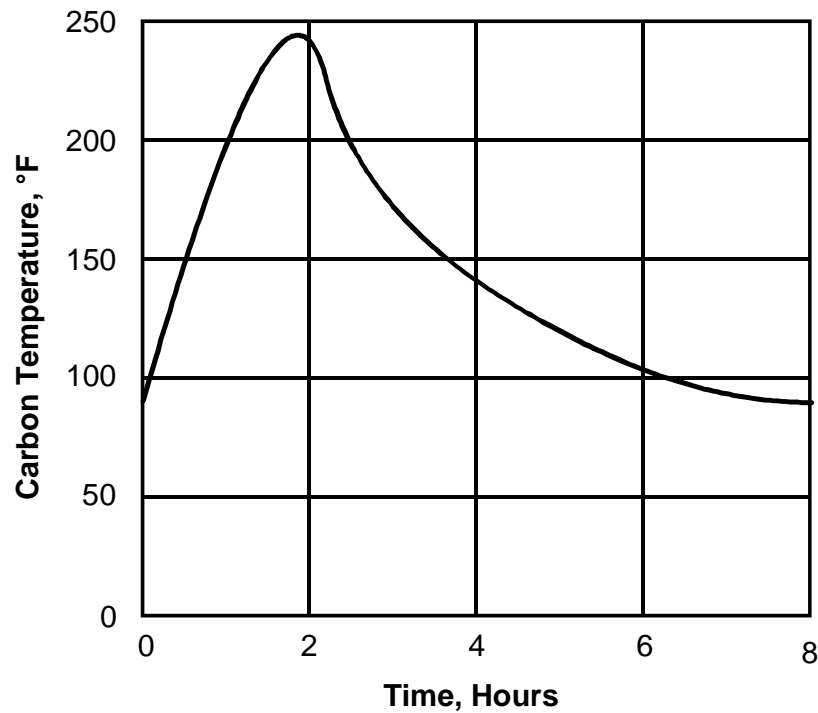

# Operator Interface

## Introduction

The incorporation of a microprocessor into the purge control system greatly enhances the flexibility of operation of the unit. The operator may adjust various setpoints, select an operating mode, and receive information on system operating status, current and cumulative purging activity, and any active fault diagnostics via an operator interface.

There are two basic types of purges covered by this manual:

- CH530 unit based display purges
- CH530 purge based display purges

The primary difference between the two purges is the location of the operator interface—the device through which the purge is controlled by the operator.

For CH530 unit based display purges, the operator interface is the CH530 chiller main panel. For a purge based display the user interface is a separable unit which may be mounted on the purge or in any convenient location on or near the chiller.

The operations of these two types of operator interfaces are very similar to each other, with the main differences found only in what other chiller information is displayed. The unit based display has the purge menus placed under and in the menus for the chiller. The purge based display has the purge menus only.

## CH530 DynaView Operator Interface

The CH530 operator interface is the DynaView display panel. It provides a means of communication between the operator and the purge microprocessor. This is accomplished via a 4" wide x 3" high 1/4 VGA touchscreen display. The DynaView display panel is illustrated below. The applicable screens relating to the setup of purge operating parameters and the review of performance data are shown in the following sections.

**Figure 14. CH530 DynaView**



On a unit based display the DynaView screens for the setup, selection of operating mode, and reporting the status of the purge are in reality subsets of the larger screens used for the control of the centrifugal water chiller.

On a purge based display the DynaView screens for the setup, selection of operating mode, and reporting the status of the purge are shown alone without the chiller level information.

The main body of the DynaView screen is used for description text, data, setpoints, or keys (touch sensitive areas of the screen).

To make viewing easier under different conditions, the contrast of the DynaView display can be adjusted by touching the lower left and lower right corner points of the touch-screen. Touching the open circle in the lower left corner will lighten the display, pressing the solid circle in the lower right corner will darken the display.

The DynaView display screens are displayed as “files.” The file folder tabs across the top of the screen can be pressed to select the various display screens. The manual sections titled “Main”, “Reports”, and “Settings” explain in detail the various screens and how to access them.

Scroll arrows are added as needed to indicate more file tabs (choices) are available. The tabs are not end around. When the tabs are at the left most position, the left navigator will not show. Only navigation to the right will be possible. Likewise when the right most screen is selected, only left navigation will be possible. The same will apply to vertical scrolling through the screens, when at the bottom-most position of a report or menu the down arrows will not appear.

Touching the double up or down arrows on the touch-screen will cause a page by page scroll either up or down. The single arrow causes a line by line scroll to occur. At the end of the screen, the appropriate scroll buttons will disappear. Wrap-around will not occur.

When a display line also contains a double arrow pointing to the right, this is an indication that more information is available and it can be accessed by touching this line again.

The bottom of the screen is called the persistent area. It is present in all screens and performs the following functions.

The **Auto** and **Stop** keys are used to put the CH530 based chiller into the auto or stop modes. The key selected is in black. These keys are not present on a DynaView applied on a stand-alone purge.

The **Alarms** button may appear to the right of the **Stop** key. The Alarms button appears only when an alarm is present, and it may blink to draw attention to the diagnostic condition. An **Alarms** button that blinks is an indication that a latching (MMR) diagnostic has occurred and the chiller or purge (if stand-alone) is locked out. A steady **Alarms** button is an indication of a non-latching (MAR or IFW) diagnostic. Pressing on the Alarms button takes you to the corresponding diagnostics tab.

## Main

The Main file of the DynaView display will show the purge units basic operating status. On a unit based DynaView it will be necessary to first press the Main file tab and then use the arrow keys to scroll down the file until the purge entries are found. On a purge based DynaView touching the Main file tab will immediately show the purge entries.

The Main file of the DynaView will show the following purge entries.

1. **Purge Operating Mode.** The possible values displayed for the Purge Operating Mode are:
  - **Adaptive**
  - **On**
  - **Off**
  - **Stop**
  - **Auto**

Refer to “[EarthWise Purge Operating Principles](#),” p. 16 for a description of the different purge operating modes.

Figure 15. CH530 Main screen



2. **Purge Status.** The possible values displayed for the Purge Status are:

- **Refrigeration Circuit On**
- **Refrigeration Circuit Idle**
- **Pumping Out**
- **Exhaust Circuit Check**
- **Pumpout Inhibited**
- **Daily Pumpout Limit Disabled**
- **Regenerating**
- **Alarm – Check Diagnostics**
- **Purge Diag Shutdown**
- **Regen Disabled**

If the Purge Status display line contains the double arrow signal, this is an indication that one or more types of status are in effect at the same time. Touching the Purge Status line again will display the multiple Purge Status types that may be in effect. For example, the purge may have the "Refrigeration Circuit Idle" status and the "Purge Diag Shutdown" status in effect simultaneously.

**Refrigeration Circuit On** is displayed when the purge condensing unit/ compressor is operating.

**Refrigeration Circuit Idle** is displayed when the purge condensing unit/ compressor is not operating.

**Pumping Out** is displayed when the purge refrigeration circuit is on and pumpout has been initiated by the purge unit controls.

**Exhaust Circuit Check** is displayed when a pumpout has been initiated by the operator.

**Pumpout Inhibited** is displayed when the purge refrigeration circuit is on but pumpout has been inhibited by a low condenser saturation temperature.

## Operator Interface

---

**Daily Pumpout Limit Disabled** is displayed when the purge refrigeration circuit is on but the operator has disabled the daily pumpout limit.

**Regenerating** is displayed when the purge carbon system is in its regeneration mode, pumpout is not allowed.

**Alarm – Check Diagnostics** is displayed when a new diagnostic has occurred.

**Purge Diag Shutdown** is displayed when the purge has shutdown on a latching diagnostic.

**Regen Disabled** is displayed when carbon regeneration is not allowed.

3. **Software Version:** The software version that has been downloaded into the DynaView is displayed.

## Reports

The Reports file of the DynaView display will show the basic operating data of the purge. To view the Purge report on the DynaView it will be necessary to first press the Reports file tab and then press the Purge line of the touch-screen.



**Table 1.**

| Purge Report Content             | Resolution   | Units       |
|----------------------------------|--------------|-------------|
| 1. Time Unit Next Purge Run      | XXXX         | Minutes     |
| 2. Daily Pumpout - 24 Hours      | XXXXX        | Minutes     |
| 3. Ave Daily Pumpout - 7 Days    | XXXXX        | Minutes     |
| 4. Daily Pumpout Limit/Alarm     | XXX          | Minutes     |
| 5. Chiller On - 7 Days           | XXX          | Percent     |
| 6. Pumpout Chiller On - 7 Days   | XXX          | Percent     |
| 7. Pumpout Chiller Off - 7 Days  | XXX          | Percent     |
| 8. Pumpout - Life                | XXXXXXX      | Minutes     |
| 9. Purge Rfgr Cprsr Suction Temp | + or - XXX.X | Temperature |
| 10. Purge Liquid Temp            | + or - XXX.X | Temperature |
| 11. Purge Carbon Tank Temp       | + or - XXX.X | Temperature |

The Purge Report in the DynaView will show the following entries:

1. **Time Until Next Purge Run – XXX.X Min** This is displayed if the purge is in its Adaptive mode and is idle. It indicates the amount of time left on the adaptive cycle timer.
2. **Daily Pumpout Last 24 Hrs – XXX.X Min** This indicates the daily pumpout time for the last 24 hours (a moving 24-hour window). This can be an indication of the chiller's hermetic integrity and allows the operator to know how the machine's hermetic integrity compares to historic pumpout times for the same chiller. It also allows a check against factory recommended values.
3. **Avg Daily Pumpout Last 7 Days – XXX.X Min** This shows the average daily pumpout time for the last 168 hours (a moving 168-hour window). This allows the operator to compare present pumpout times to past averages, and can be another indication of the chiller's hermetic integrity.
4. **Daily Pumpout Limit/Alarm – XXX Min** This shows the limit value that has been set by the operator in the Settings menu. When the daily pumpout rate exceeds this value purge operation is shut down and a diagnostic is generated.
5. **Chiller On - 7 Days – XXX%** This provides the percent of the past 7 days (floating 168-hour window) in which the chiller was operating. It is used to help the operator determine if a leak is present on the high side or the low side of the chiller.
6. **Pumpout Chiller On - 7 Days – XXX%** Indicates what percent of the total purge pumpout time of the last week occurred when the chiller was running. It is used to help the operator determine if a leak is present on the high side or the low side of the chiller.
7. **Pumpout Chiller OFF - 7 Days – XXX%** Indicates what percent of the total purge pumpout time of the last week occurred when the chiller was off. It is used to help the operator determine if a leak is present on the high side or the low side of the chiller.
8. **Pumpout – Life – XXXXXXX.X Min** Shows the total purge pumpout minutes accumulated over the life of the purge.
9. **Purge Suction Temp – XXX °F or °C** Indicates the purge refrigeration circuit's condensing suction temperature. This is useful for diagnosing purge system problems.
10. **Purge Liquid Temp – XXX °F or °C** Displays the temperature sensed by the control and used to inhibit purge operation. The purge liquid temperature sensor on a factory installed purge is the chiller's saturated condenser temp sensor when the chiller is running, and it is the chiller's saturated evaporator temperature sensor when the chiller is off. If this temperature is below the Pumpout Inhibit Temperature that is defined in the Settings menu, pumpout will not be allowed. This is used to prevent inefficient operation of the purge under some conditions.
11. **Carbon Temperature – XXX °F or °C** This indicates the carbon bed temperature and is useful for monitoring regeneration and for diagnosing regeneration system problems.

## Settings

The Settings file of the DynaView display will show the values that allow the operator to manually set operating modes and setpoints to best suit the given chiller application. Three different menus are available that will affect the operation of the purge. They are the Purge menu, the Mode Overrides menu, and the Display Settings menu. To view the menus in a DynaView it will be necessary to first touch the Settings file tab and then touch the appropriate Purge, Mode Override, or Display Setting line of the touch-screen.

Selecting the Purge menu of the DynaView Settings file will show the following Purge setpoints:

1. **Purge Operating Mode**

Possible choices are:

- **Adaptive** (default)
- **On**
- **Stop**
- **Auto**

To change the operating mode it is necessary to first touch the Purge Operating Mode line of the touchscreen display, then touch the 'button' on the touch-screen that represents the desired operating mode.

2. **Daily Pumpout Limit – XXX Min** This is used by the operator to set the allowable amount of daily pumpout time. The range is from 1 to 50 minutes; the factory default is 10 minutes.

To change the setpoint of the Daily Pumpout Limit it is necessary to first press the Daily Pumpout Limit line of the touch-screen display, then press the up or down arrows to set the desired value. The Enter button on the display must then be touched to store the value.

**Figure 16. Settings screen for stand-alone Purge**



**Table 2.**

| Purge Settings                            | Resolution                 | Default          |
|---|----------------------------|------------------|
| 1. Purge Operating Mode                   | (Auto, On, Adaptive, Stop) | Adaptive         |
| 2. Daily Pumpout Limit                    | XXX Minutes                |                  |
| 3. Disable Daily Pumpout Limit            | 0, XX Hours                | 0 (0 to disable) |
| 4. Refrigerant Type (Retrofit Purge Only) | (R123, R11, R113)          | R123             |
| 5. Purge Liquid Temp Inhibit              | (Enable, Disable)          | Enable           |
| 6. Purge Liquid Temp Limit                | XXX.X                      |                  |

3. **Disable Daily Pumpout Limit: XX hrs.** For the time specified here the user can disable alarms associated with exceeding the daily pumpout limit. This is useful when large amounts of purging are needed following chiller servicing or operator error. The range is from 0 to 72 hours, the factory default is 0 hours. Any setting greater than 0 hours will effectively disable the Daily Pumpout Limit for the amount of time selected.

To change the setting of the Disable Daily Pumpout Limit it is necessary to first press the Disable Daily Pumpout Limit line of the touch-screen display, then press the up or down arrows to set the desired value. The Enter button on the display must then be pressed to store the value.

4. **Refrigerant Type:** On stand-alone purges the operator can use this setting to define the chiller's refrigerant type. Available choices are R-123, R-113, and R-11.

**Important:** Refrigerant type must be set to correctly match the refrigerant installed in the chiller.

**Table 3. Manual control settings**

| Description                   | Resolution | Default | Monitor Value |
|-------------------------------|------------|---------|---------------|
| 1. Purge Exhaust Circuit Test | (Off, On)  | Off     | None          |
| 2. Purge Regen Cycle          | (Off, On)  | Off     | Carbon Temp   |

5. **Purge Liquid Temp Inhibit - Enable/Disable** The user can enable or disable the inhibit feature that prevents purge pumpout if the sensed purge liquid temperature is less than the Pumpout Inhibit Temperature setpoint.
6. **Purge Liquid Temperature Limit – XXX °F or °C** The user can define the setpoint for the Purge Liquid Temp Inhibit feature. If the sensed chiller refrigerant temperature is below this value, pumpout will not be allowed. The allowable range is 32°F (0°C) to 50°F (10°C). Factory default is 40°F (4.4°C).

Selecting the Manual Control Settings menu of the DynaView Settings file will show the following Purge parameters:

- Purge Exhaust Circuit Test – On or Off.** Factory default is Off. Setting this to On will initiate a 30-second non-condensable pumpout cycle. This may be used for checking exhaust circuit components.
- Purge Regen Cycle – On or Off** Factory default is off. This setting allows the user to manually start a carbon regeneration cycle

Selecting the Display Settings menu of the DynaView Settings file will show the following parameters:

- Date Format: mmm dd, yyyy**  
By pressing this line the operator can select the format which is used to present the date. The available choices are:

mmm dd, yyyy (month-day-year)  
dd-mmm-yyyy (day-month-year)

The time and date are displayed along with any diagnostics that have occurred.

2. **Date: mmm dd, yyyy**  
By pressing this line on the touch screen of the DynaView the operator can set the correct date. A screen will appear on which he can select the value that is to be changed (Day, Month, or Year), and the up or down arrow buttons can be used to adjust the parameter. The enter button must be pressed after the desired value is set.
3. **Time Format: XX-hour**  
By pressing this line on the touchscreen of the DynaView the operator can set the unit clock to display in either a 12-hour or 24-hour format. A screen will appear on which the operator can select the desired format.
4. **Time of Day: XX:XX**  
By pressing this line on the touchscreen of the DynaView the operator can set the correct time. A screen will appear on which he can select the value that is to be changed (Hour or Minute), and the up or down arrow buttons can then be used to adjust the value. The enter button must be pressed after the desired value is set.

**Table 4. Display settings**

| Description               | Resolution                          | Default        | Note |
|---------------------------|-------------------------------------|----------------|------|
| 1. Date Format            | ("mmm dd, yyyy",<br>"dd-mmm-yyyy")  | "mmm dd, yyyy" |      |
| 2. Date                   | Day, Month, Year settings screen    |                |      |
| 3. Time Format            | (12-hour, 24-hour)                  | 12-hour        |      |
| 4. Time of Day            | Hour, Minutes settings screen       |                |      |
| 5. Keypad/Display Lockout | (Enable, Disable)                   | Disable        | (a)  |
| 6. Display Units          | (SI, English)                       | English        |      |
| 7. Language (9)           | (English, Selection 2, Selection 3) | English        | (b)  |

(a) Enables a DynaView Lockout screen. All other screens time-out in 30 minutes to this screen. The DynaView Lockout Screen will have 0–9 keypad to permit the user to re-enter the other DynaView screens with a fixed password. Further details follow.

(b) Language choices are dependent on what the Service Tool has setup in the Main Processor. Get Radio Button names from Main Processor setups. Language selections will include English and qty 2 alternate as loaded by TechView™.

5. **Keypad/Display Lockout: Enable/Disable**  
By touching this line of the DynaView touch-screen the operator can change the value of the Keypad/Display Lockout. A screen will appear on which the operator can touch either the Disable or Enable buttons. If the operator touches the Disable button, the Keypad/Display Lockout function of the DynaView will NOT be operational, the keypad and display will remain accessible to any operator. If the operator presses the Enable button, the Keypad/Display Lockout feature of the DynaView will be operational.  
  
If the Keypad/Display Lockout is enabled, the display will lock itself if no button or key is touched for a period of 5 minutes. If the display is locked, touching the touchscreen will only cause a numerical keypad to appear. To access the DynaView the operator must set the correct code using the numerical keys and then press the enter button. The code is 1 - 5 - 9.
6. **English or SI Display**  
This setting allows the user to determine if values are displayed in English (°F) or SI (°C; System International) units. By touching this line on the touch-screen of the DynaView the operator can set the unit to display in either English or SI format. A screen will appear on which the operator can select the desired format.
7. **Display Language**  
This setting allows the user to select the language of the display. Touching this line on the touchscreen of the DynaView will cause a screen to appear on which the operator can select the desired display language.

## Viewing Diagnostics

When a diagnostic is present in the CH530 system the DynaView display will show a steady or a flashing **Alarms** button. A steady **Alarms** button indicates a non-latching (MAR) or informational diagnostic (IFW) has occurred. A flashing **Alarms** button indicates a more serious latching (MMR) diagnostic is present and chiller (or stand-alone purge) shutdown has occurred. If no diagnostics exist the Alarms button will not be present.

When alarms or diagnostics are present in the CH530 system they may be viewed by simply pressing the **Alarms** button. A screen will then appear that will display a scroll list of the last 10 active diagnostics. Each diagnostic event is “stamped” with the date and time it occurred, and the list is sorted according to this time stamp.

A button labeled **Reset Diags** will appear in the upper right hand corner of the diagnostics screen. Touching the **Reset Diags** button will reset all active diagnostics regardless of type.

The purge diagnostics that may occur in the CH530 based system are:

**Purge Compressor Suction Temp Sensor** (latching diagnostic—purge will shutdown)

**Purge Liquid Temp Sensor** (latching diagnostic—purge will shutdown)

**Purge Carbon Tank Sensor** (latching diagnostic—purge will shutdown)

**Purge Liquid Level Too High** (non-latching diagnostic)

**Purge Liquid Level Too High Continuously** (latching diagnostic—purge will shutdown)

Figure 17.



**Purge Carbon Regen Temp Too Low** (non-latching diagnostic)

**Carbon Regeneration Temperature Setpoint Not Satisfied** (non-latching diagnostic)

**Carbon Regeneration Temperature Limit Exceeded** (latching diagnostic—purge will shutdown)

**Purge Daily Pumpout Exceeded** (latching diagnostic—purge will shutdown)

**Comm Loss: xxx** (latching diagnostic—purge will shutdown)

Refer to “[Troubleshooting Using Purge Diagnostics](#),” p. 42 for information regarding the different purge diagnostics.



# Maintenance

## Periodic Maintenance

The following information describes the maintenance requirements for the CH530-equipped EarthWise Purge. To assure efficient and reliable purge operation, perform all inspections and procedures at the prescribed intervals. Keep a record of all inspection results to establish proper service intervals and document changes that occur in purge activity that could reflect on chiller performance.

The following sections describe the required periodic maintenance:

- Weekly
- Semi-Annually
- Annually

### **WARNING** **Contains Refrigerant!**

**System contains oil and refrigerant under high pressure. Recover refrigerant to relieve pressure before opening the system. See unit nameplate for refrigerant type. Do not use non-approved refrigerants, refrigerant substitutes, or refrigerant additives.**

**Failure to follow proper procedures or the use of non-approved refrigerants, refrigerant substitutes, or refrigerant additives could result in death or serious injury or equipment damage.**

### **WARNING** **Hazardous Voltage!**

**Disconnect all electric power, including remote disconnects before servicing. Follow proper lockout/tagout procedures to ensure the power can not be inadvertently energized. Failure to disconnect power before servicing could result in death or serious injury.**

### **CAUTION** **Hot Surfaces!**

**Surface temperatures may exceed 300°F (150°C) on condensing unit and carbon tank. Contact of bare skin on hot surfaces may result in minor to severe burns.**

#### **Weekly**

1. With the purge unit operating, check the purge tank condensing activity by observing the liquid refrigerant flow in the moisture indicating sight glass located in the liquid drain line immediately after the filter drier canister. A lack of visible refrigerant flow in the drain line sight glass indicates:
  - A pumpout cycle is necessary, or,
  - A problem exists with the purge heat transfer circuit (air-cooled condensing unit, expansion device, purge tank coil, etc.), or,
  - A problem exists in the purge control circuit, or,
  - Refrigerant vapor from the chiller condenser is blocked or restricted.
2. Check the moisture indicator on the purge liquid return line sight glass. Replace the filter-drier core if moisture is indicated.

**Note:** *The need for frequent changes of the filter drier could be an indication of significant chiller air or tube leaks.*

### Semi-Annually

1. Inspect the air-cooled condenser coil and clean as needed. Clean the coil from the fan side using compressed air or coil cleaner. A fouled coil will reduce purge efficiency and capacity.
2. Inspect the purge tank and carbon tank insulation for any damage or degradation. Make any needed repairs to the insulation.

### Annually

1. Perform the semi-annual maintenance procedures.
2. Perform the purge system control checks described in the troubleshooting section.
3. Open the purge control panel and check all internal components for corrosion, terminal tightness, signs of overheating, etc.
4. Change the return line filter-drier assembly.

## Filter-Drier Assembly Replacement

Following are maintenance instructions for filter-drier assembly replacement; refer to [Figure 18](#).

1. Set the purge operating mode to "STOP."
2. Isolate the purge unit from the chiller. Close the isolation valves on the purge vapor inlet and the liquid return lines.
3. Drain the filter-drier of liquid refrigerant prior to opening. Use available pressure differential whenever possible. Connect a refrigeration hose to the 1/4-inch Schrader drain fitting located on the drain line isolator valve and also to a service valve on the chiller evaporator. Open the chiller valve and drain the filter drier.

**Figure 18. Filter-drier**

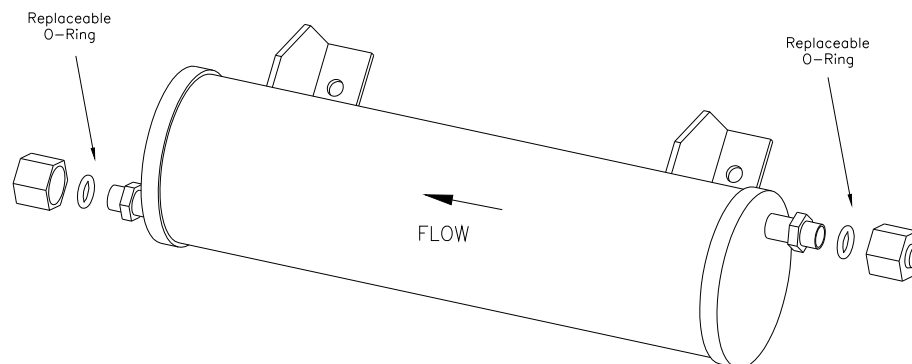

4. Remove the refrigerant vapor inside the filter-drier by connecting the suction side of a vacuum pump to the Schrader drain fitting and the pump's discharge to the chiller. Pull a vacuum for approximately 30 minutes.

### Notes:

- Due to the slow out-gassing of refrigerant from the filter-drier, it will not be possible to pull and hold a deep vacuum.
  - The replacement filter-drier absorbs water vapor from the ambient air, so it is shipped with sealing caps on each end. Do not remove these caps until immediately before installation.
5. Remove the screws connecting the filter-drier to the Purifier Purge base. Loosen the nuts at each end of the filter-drier and slide it out from the adjacent tubing. Immediately cap the two ends with the caps from the replacement filter-drier. Dispose of the old filter-drier in accordance with local regulations.

## Maintenance

---

6. Install the new filter-drier using new O-rings supplied with the assembly.
7. Pressurize the purge with dry air or nitrogen to 10 psig through the schrader drain valve and check for leaks. Release the pressure, remove hoses and replace all valve caps.
8. Set the purge operating mode to "On" and wait for the purge pumpout compressor to start.
9. Open the isolation valves on the vapor inlet lines and the liquid return line.
10. After purge pumpout stops, or after several minutes, return the purge operating mode to "Auto" or "Adaptive" (recommended).

### Moisture Monitoring and Removal

A moisture indicator is provided in the liquid return line from the purge tank to the chiller condenser, this allows the machine operator to monitor the quality of the liquid refrigerant in the chiller.

Inspect the moisture indicator periodically. The indicator will show "wet" whenever the chiller moisture exceeds the levels shown in [Table 5](#). Notice that the indicator becomes more sensitive as the temperature decreases. (The moisture indicator normally operates at equipment room ambient temperatures.) A "wet" indication for more than 72 hours typically indicates the filter drier is saturated and should be replaced. A reoccurring or persistent "wet" indication is a sign of possible chiller air or water infiltration.

Consult the moisture indicator only under these conditions:

1. The chiller is operating.
2. The purge unit is operating and has been allowed sufficient time to properly remove system moisture (allow a minimum of 72 hours after replacing filter-drier cores).

**Table 5. Refrigerant moisture content as determined by moisture indicator**

| Refrigerant<br>Moisture<br>Level | CFC-11   |          |          | HCFC-123 |          |           |
|----------------------------------|----------|----------|----------|----------|----------|-----------|
|                                  | 75°F     | 100°F    | 125°F    | 75°F     | 100°F    | 125°F     |
| Dry                              | Below 5  | Below 10 | Below 20 | Below 20 | Below 30 | Below 35  |
| Caution                          | 5–15     | 10–30    | 20–50    | 20–50    | 30–80    | 35–100    |
| Wet                              | Above 15 | Above 30 | Above 50 | Above 50 | Above 80 | Above 100 |

**Note:** Refrigerant Moisture content given in parts per million (ppm)

### Moisture Indicating Sight Glass.

In normal operating conditions the moisture indicating sight glass should not require maintenance beyond keeping the sight glass clean. However, the sight glass should be replaced after any major repair to the unit has taken place, or if it is on a unit where severe moisture contamination is known to have occurred.

Be aware that it is normal for the sight glass to indicate moisture is present for a period of least 72 hours after it is installed or after it has been exposed to atmosphere. Allow a minimum of 72 hours after sight glass installation or filter-drier service before using the sight glass to determine the system moisture content.

### Purge Operation After Major Chiller Repairs

In those situations where air has entered the chiller during servicing, it will have to be removed before the chiller can be started. The EarthWise Purge can accomplish this task with minimal changes to its normal operation.

Using the DynaView interface of the purge control, select the "Settings" file and then select the "Purge" menu. In the "Purge" menu, press the "Disable Daily Pumpout Limit" line of the touch-screen display. A screen will appear in which the up or down arrow can be pressed to select the

desired new value. Any setting greater than '0' hours will effectively disable the "Daily Pumpout Limit" for the amount of time selected.

The range of available settings is from 1 to 72 hours in 1-hour increments. Typically, 24 hours is sufficient.

This mode will allow the purge to pumpout for extended periods of time without signaling a diagnostic for excessive pumpout time. The "Disable Daily Pumpout Limit" mode will automatically de-energize and return the purge controls to normal operation after the selected time has expired.

**Important:** *Do not bypass or remove the pumpout restrictor of an EarthWise Purge. Failure to follow this caution could reduce the efficiency of the purge.*

**Note:** *Unlike earlier Purifier Purges, the EarthWise Purge does not have a pumpout restrictor that can be bypassed or removed in order to speed the air removal process. The purge has an air exhaust rate that is faster than previous purges and bypassing or removing the restrictor is unnecessary and is detrimental to the air removal process. Do not bypass or remove the pumpout restrictor of a EarthWise Purge.*

When large amounts of non-condensables are present in the chiller, air removal rate can be enhanced by operating the chiller as soon as it is practical, at part load conditions. The amount of time that the purge pumpout compressor operates continuously will vary, depending on the quantity of non-condensables in the chiller. Initially, the pumpout compressor operates continuously due to the large amount of non-condensables and the relatively small amount of refrigerant being drawn into the purge tank. It may be several hours before the pumpout compressor cycles off for the first time.

Once the level of non-condensables present in the chiller falls to a point where increasing amounts of refrigerant are entering the purge tank, the temperature control in the purge control system will begin to cycle the pumpout compressor on and off. As the refrigerant in the system becomes less contaminated with non-condensables, purge pumpout is activated less frequently. If the chiller is also suspected to contain moderate amounts of moisture after servicing, several filter-drier assembly changes may be required before a satisfactory moisture level is achieved.



# Troubleshooting Using Purge Diagnostics

## **⚠️ WARNING**

### **Contains Refrigerant!**

System contains oil and refrigerant under high pressure. Recover refrigerant to relieve pressure before opening the system. See unit nameplate for refrigerant type. Do not use non-approved refrigerants, refrigerant substitutes, or refrigerant additives.

Failure to follow proper procedures or the use of non-approved refrigerants, refrigerant substitutes, or refrigerant additives could result in death or serious injury or equipment damage.

## **⚠️ WARNING**

### **Hazardous Voltage!**

Disconnect all electric power, including remote disconnects before servicing. Follow proper lockout/tagout procedures to ensure the power can not be inadvertently energized. Failure to disconnect power before servicing could result in death or serious injury.

## **⚠️ CAUTION**

### **Hot Surfaces!**

Surface temperatures may exceed 300°F (150°C) on condensing unit and carbon tank. Contact of bare skin on hot surfaces may result in minor to severe burns.

## Troubleshooting Procedures

If operational difficulties are encountered, use the diagnostic chart and checkout procedures to determine the cause and correct the problem.

### **Non-Latching diagnostics**

Purge operation will be allowed to continue.

### **Latching diagnostics**

Purge operation will be prohibited until the condition has been corrected and the diagnostic has also been manually reset from the DynaView or TechView menus.

## Troubleshooting Using Purge Diagnostics

| Diagnostic or Problem   | Cause   | Solution   |
|---|---|--|
| Purge Cprsr Suction Temp Sensor (latching diagnostic)   | Bad Sensor or LLID  | The purge compressor suction temperature sensor has failed. The connection has been broken or a short has occurred in the wiring, or the LLID is not programmed or functioning correctly. Replace or repair as required.   |
| Purge Liquid Temp Sensor (latching diagnostic)  | Bad Sensor or LLID  | The purge liquid temp sensor has failed. The connection has been broken or a short has occurred in the wiring, or the LLID is not programmed or functioning correctly. Replace as required.  |
| Purge Carbon Tank Temp Sensor (latching diagnostic)   | Bad Sensor or LLID  | The purge carbon tank temp sensor has failed. The connection has been broken or a short has occurred in the wiring, or the LLID is not programmed or functioning correctly. Replace as required.   |
| Purge Liquid Level Too High (nonlatching diagnostic)  | High liquid level in purge tank or bad level switch. The level switch was open for at least 20 minutes.   | Check for restrictions in the in the vapor pick-up line and in the liquid return line. Ensure the vapor line is sloped correctly and has no liquid traps. Change filter drier if required. Ensure the line shutoff valves are open.  |
| Purge Liquid Level Too High Continuously (latching diagnostic)  | High liquid level in purge tank or bad level switch. The level switch was open for more than 20 minutes, or the liquid level/ refrigeration circuit restart cycle has occurred more than 4 times in 4 hours.    | Check for restrictions in the in the vapor pick-up line and in the liquid return line. Ensure the vapor line is sloped correctly and has no liquid traps. Change filter drier if required. Ensure the line shutoff valves are open.  |
| Purge Carbon Regen Temp Too Low (non-latching diagnostic)   | The carbon tank temperature did not increase more than 25°F in the first 2 hours after energizing the carbon tank heater.   | This diagnostic is intended to identify a failed heater or sensor. Check carbon tank heater and heater wiring. Check the carbon tank temperature sensor and its wiring. Check the carbon tank insulation and the surrounding ambient temperature. Check the purge unit controls and settings.  |
| Carbon Regeneration Temperature Setpoint Not Satisfied (non-latching diagnostic)                                      | The carbon tank temperature sensor did not reach the minimum regeneration temperature setpoint within 4 hours after energizing the heater.  | This is intended to identify a failing insulation system. Check carbon tank insulation for integrity. Check ambient conditions. Check heater operation.  |
| Carbon Regeneration Temperature Limit Exceeded (latching diagnostic)  | The carbon tank temperature exceeded 120 percent of the regeneration temperature setpoint.<br><br>The carbon tank temperature did not decrease more than 25°F in the first hour after the heater is turned off. | Check carbon tank heater relay and heater wiring. Check the carbon tank temperature sensor and its wiring. Check the purge unit controls and settings.   |
| Purge Daily Pumpout Limit Exceeded latching diagnostic)   | The pumpout time recorded over the past 24 hours has exceeded the daily pumpout limit setpoint.   | Air infiltration rate into chiller may be too high, leak check chiller and repair leaks. The daily pumpout limit setpoint may be set too low. Check and adjust to proper value. The chiller's refrigerant temperature may be too low. Do not operate purge at condensing temps of 40°F (4.4°C) or lower. High vacuum pumpouts may be operated down to 32°F (0°C). Set pumpout inhibit to ENABLE and set appropriate limit. |
| Comm Loss: xxxx (latching diagnostic)   | A loss of communication of more than 30 continuous seconds has occurred between the main processor (DynaView) and the identified component (LLID).  | Check the LLID and the interconnecting IPC bus. Check the LLID configuration and function using the service tool for CH530.  |
| Purge unit does not run or pumpout system does not run.   | Control circuit problem.  | Run diagnostics of purge control system. Refer to the control circuit test. Check the purge control for active diagnostics. Check the purge control system using the TechView service tool.  |
| Purge continues to operate when chiller is "off."   | Purge is set to ON or to ADAPTIVE.  | Normal operation. The ON mode should be used only for certain service procedures. ADAPTIVE is the normal operating mode.   |
| Pumpout compressor operates continuously.<br>Purge suction temperature is greater than the pumpout initiate setpoint. | Purge suction temperature sensor has failed.<br>Purge CH530 control system has failed.  | Check sensor, LLID, and IPC bus.<br>Check CH530 system using diagnostic tools.   |

## Troubleshooting Using Purge Diagnostics

| Diagnostic or Problem  | Cause  | Solution   |
|--|--|--|
| Purge fails to pumpout non-condensables. Chiller observations indicate air is actually present in the chiller i.e. measured condenser pressure is greater than measured condenser temperature converted to pressure, and/ or chiller surges at start-up. | Depending on the chiller type and the operating conditions, air may accumulate in the chiller condenser away from the purge vapor pick-up location. (retrofit purge) | Operate the purge with the chiller "off." Any air in the chiller will be removed if the purge is functioning correctly. If a large amount of air is removed, leak test the chiller and repair leaks. Consider using the Adaptive mode to run the purge as required when the chiller is "off." If non-condensable removal is required during chiller operation, relocate the vapor/liquid connections to a more effective location. |
|  | Pumpout restrictor plugged.  | Clean out restrictor orifice with compressed air (preferred) or a small wire.  |
|  | Purge condensing unit is overcharged or undercharged.  | Refer to <a href="#">"Refrigeration System Diagnostic Procedure," p. 45</a> to evaluate the purge charge level.  |
|  | Purge expansion valve has failed.  | Refer to <a href="#">"Refrigeration System Diagnostic Procedure," p. 45</a> to evaluate the purge expansion valve performance.   |
|  | Pumpout circuit fault.   | Run diagnostic of purge control circuit. Refer to control circuit test.  |
|  | Purge condensing unit fan has failed.  | Test and replace fan as needed.  |
|  | Purge condensing unit condenser coil is fouled.  | Clean condenser coil as required.  |
|  | Condensing unit compressor motor winding temperature sensor opened (line break t-stat).  | Check condensing fan and coil. Check purge condensing unit charge level. Check purge condensing unit compressor.<br>Check purge power supply. Replace line break protector if needed. Replace compressor if needed.  |
|  | Pumpout compressor fault—does not run  | Low voltage, no voltage, failed pump motor, failed controls.   |
|  | Pumpout compressor fault—pump motor runs   | Failed pump diaphragm, failed pump reed valves, fitting leaks, line restrictions, high pressure drop across the pump.  |
| Pumpout compressor operates continuously. Purge suction temperature is less than the pumpout initiate setpoint.  | Purge Compressor Suction Temperature Sensor  | Not installed correctly or the thermal conductive paste has degraded. Install sensor in its proper orientation and install thermal conductive paste.   |
|  | Purge is set to AUTO and the chiller run signal has failed   | Check the chiller run signal (retrofit purge). Check the CH530 control system.   |
|  | Excessive air in chiller.  | Trace air source and repair any leak paths. Allow purge to remove accumulated air.   |
|  | Leakage in purge or purge pumpout tubing.  | Check all connections on purge and between the purge tank and the pumpout compressor. Check all solenoids etc. for possible leakage.   |
|  | Failed or restricted solenoid.   | Failure of the pumpout solenoid to open, or a failure of the exhaust solenoid to open. Check for dirt or contamination, failed or misaligned armature, or an incorrect control command from the CH530.   |
|  | Pumpout restrictor plugged.  | Failure of the pumpout solenoid to open, or a failure of the exhaust solenoid to open. Check for dirt or contamination, failed or misaligned armature, or an incorrect control command from the CH530.   |
|  | Gas pick-up connection of the purge is below the liquid level of the condenser.  | Refer to the installation instructions of a retrofit purge. Check overall unit operation.  |
|  | Gas pick-up or return line restricted.   | Ensure shut-off valves are fully open and remove any restrictions.   |
|  | Restriction in Exhaust lines.  | Check carbon tank for restriction, check solenoid valves for restriction, check outlet tubing from the carbon tank to the chiller vent line.   |

## Refrigeration System Diagnostic Procedure

If there is concern that one of the components in the purge refrigeration system is not operating correctly, you may troubleshoot the system by taking **surface temperature measurements**.

### **WARNING**

#### **Contains Refrigerant!**

**System contains oil and refrigerant under high pressure. Recover refrigerant to relieve pressure before opening the system. See unit nameplate for refrigerant type. Do not use non-approved refrigerants, refrigerant substitutes, or refrigerant additives.**

**Failure to follow proper procedures or the use of non-approved refrigerants, refrigerant substitutes, or refrigerant additives could result in death or serious injury or equipment damage.**

### **CAUTION**

#### **Hot Surfaces!**

**Surface temperatures may exceed 300°F (150°C) on condensing unit and carbon tank. Contact of bare skin on hot surfaces may result in minor to severe burns.**

The critical temperature measurements needed to diagnose the system properly are shown on [Figure 19, p. 46](#).

The temperature at Point 1 may be obtained by moving aside a small portion of the insulation covering the tubing between the expansion valve and the purge tank. The condensing unit suction temperature, Point 2, is a part of the purge control system and may be read directly from the DynaView display but should be confirmed using a surface mounted thermo-couple. The condenser temperature, Point 3, may be measured by removing the sheet metal cover from the side of the condenser and reading the surface temperature of the second or third condenser tubing u-bend from the top on the side of the coil opposite the discharge gas inlet. The liquid line temperature, Point 4, may be measured on the tubing between the purge condenser and the expansion valve.

**Figure 19. Purifier Purge refrigerant circuit schematic**



**Note:** Use an accurate ( $\pm 1^{\circ}\text{F}$ ) surface mounted thermo-couple type temperature probe with a range of  $-40^{\circ}\text{F}$  ( $-40^{\circ}\text{C}$ ) to  $200^{\circ}\text{F}$  ( $93.3^{\circ}\text{C}$ ) to take temperature readings. Fasten the sensor of the probe tightly against the tubing surface and insulate around the sensor for accurate results. Be aware that the presence of ice on the surface to be measured will result in a measurement error, so remove all ice before attaching the sensor to the tubing surface. The following sections describe diagnostic procedures for these elements of the refrigeration system:

- Charge Level
- Expansion Valve

### Charge Level

The purge refrigeration system must have a proper charge of R-404A before any other refrigeration circuit components may be evaluated.

Suction pressure is not a good indicator of proper charge. The best method to determine proper charge level is to measure surface temperatures at various points on the refrigeration circuit. These points are shown on the [Figure 7, p. 17](#).

With the purge condensing unit running, take temperature measurements at Point 4 and Point 5. The difference between these two values is the sub-cooling. This value should be between  $8^{\circ}\text{F}$  ( $4.4^{\circ}\text{C}$ ) and  $15^{\circ}\text{F}$  ( $8.3^{\circ}\text{C}$ ) with the proper refrigerant charge in the system.

- A sub-cooling of less than  $5^{\circ}\text{F}$  ( $2.7^{\circ}\text{C}$ ) indicates a possible refrigerant undercharge and a possible leak.
- A subcooling value greater than  $20^{\circ}\text{F}$  ( $11^{\circ}\text{C}$ ) indicates a refrigerant overcharge.

## Expansion Valve

With the purge condensing unit operating, the expansion device will reliably regulate the low side of the purge refrigerant system, even with a relatively wide range of refrigerant charge.

The purpose of the expansion valve is to regulate refrigerant flow in order to maintain a constant pressure within the purge tank coil. The constant pressure will result in a constant temperature on the refrigerant entering the purge tank. To determine if the expansion valve is operating properly, measure the temperature at Point 1 on Figure 16. An optimum constant temperature of -16°F (-26.6°C) should be measured at this point. However, depending on operating conditions and or measurement error a measurement between -20°F (-28.9°C) and -10°F (-23.3°C) is acceptable.

## Chiller Vapor/Liquid

**Connections** The vapor pick-up and liquid return connections must be properly located on the chiller condenser to ensure correct purge operation. During chiller operation non-condensables will accumulate in the coolest, calmest spot in the condenser above the liquid level. On a Trane® chiller this location is typically just under half-way up the condenser shell above the condenser sump. An internal baffle is installed to enhance this effect during chiller operation.

During chiller OFF cycles non-condensables may rise to higher elevations within the chiller. However, with the purge operating a continuous thermal siphon will develop which will effectively draw the non-condensables into the purge tank.

In addition to the correct pick-up and return locations, the lines must be sloped a minimum of 2 inches per foot off horizontal or vertical to ensure no liquid or vapor traps exist. If the purge is a retrofit application, refer to the installation manual for the purge.

## Using The Service Functions

### Purge regen cycle

This test may be initiated using the DynaView or TechView interface (service tool) of the CH530/CH531 control. This mode override function allows the servicing technician to manually initiate a carbon tank regeneration cycle. When this function is turned on or enabled a normal regeneration cycle will begin. The technician should observe that the purge condensing unit will stop, the pumpout solenoid will close (if open), the regeneration solenoid will open, and the carbon tank heater will energize. The technician can check the solenoid position and confirm the energy consumption by the heater. Continued monitoring of the cycle can be used to determine that the regeneration setpoints are achieved and that timing functions are correct. Refer to ["EarthWise Purge Operating Principles," p. 16](#) for information regarding the regeneration cycle.

### Exhaust circuit check

This test may be initiated using the DynaView or TechView interface of the CH530/CH531 control. This mode override function serves to check that the exhaust circuit components activate in the right sequence and at the right time when commanded to do so by the controls.

## Troubleshooting Using Purge Diagnostics

**Table 6. Purge component status**

| Displayed Purge Status       | Component       |                    |                  |                  |                       |                    |
|------------------------------|-----------------|--------------------|------------------|------------------|-----------------------|--------------------|
|                              | Condensing Unit | Pumpout Compressor | Pumpout Solenoid | Exhaust Solenoid | Regeneration Solenoid | Carbon Tank Heater |
| Refrigerant Circuit On       | •               | ○                  | ○                | ○                | ○                     | ○                  |
| Refrigerant Circuit Idle     | ○               | ○                  | ○                | ○                | ○                     | ○                  |
| Pumping Out                  | •               | •                  | X                | •                | ○                     | ○                  |
| Regenerating                 | X               | ○                  | ○                | ○                | X                     | X                  |
| Exhaust Circuit Check        | •               | •                  | •                | •                | ○                     | ○                  |
| Pumpout Inhibited            | •               | ○                  | ○                | ○                | ○                     | ○                  |
| Daily Pumpout Limit Disabled | •               | X                  | X                | X                | ○                     | ○                  |
| Purge Diag Shutdown          | ○               | ○                  | ○                | ○                | ○                     | ○                  |

**Note:**

- = Off or De-energized
- = On or Energized
- X = Cycling on internal algorithm

When it is turned to “On” or enabled, this function overrides the pumpout algorithm and executes a pumpout sequence regardless of the actual purge suction temperature. Once activated, the pumpout sequence will be active for 30 seconds. The servicing technician can observe and confirm that the pumpout compressor starts and the exhaust solenoid opens. After 5 seconds the pumpout solenoid should also open.

### Exhaust circuit pressure check

This test may be initiated only from the TechView interface of the CH530/CH531 control. This function allows the servicing technician to check the exhaust circuit components and lines for leakage by pressurizing the exhaust circuit. Before initiating the test the technician must first install a pressure gauge, isolation valve, pressure regulator, and a source of dry compressed air or nitrogen to the line downstream of the exhaust solenoid valve. When this check is enabled the exhaust solenoid will be opened, the technician should then pressurize the exhaust circuit to no more than 10 psi using dry air or nitrogen. After the target pressure is achieved the pressure source should be isolated and the pressure gauge then monitored for decay. A loss of pressure would be an indication of leakage from the exhaust system.

The exhaust components and line connections can also be tested for leaks using a soap solution. Relieve the testing pressure from the exhaust circuit before disabling this test. When the test is disabled the exhaust solenoid valve will re-close.

### Exhaust circuit vacuum check

This test may be initiated only from the TechView interface of the CH530 control. This function allows the servicing technician to check the exhaust circuit components and lines for leakage by placing a vacuum on the exhaust circuit. Before initiating the test the technician must first install a vacuum gauge, isolation valve, and a vacuum source to the line downstream of the exhaust solenoid valve. When this check is enabled the exhaust solenoid will be opened, the technician should then turn on the vacuum source and pull the exhaust circuit to as deep a vacuum as can be achieved. After a vacuum is achieved the vacuum source should be isolated and the vacuum gauge then monitored for decay. A rise in pressure may be an indication of leakage into the exhaust system (note: out-gassing of refrigerant from the carbon tank may give a false indication of a pressure rise). Relieve the vacuum from the exhaust circuit before disabling this test. When the test is disabled the exhaust solenoid valve will re-close.

# Electrical

## Purge Control System

The EarthWise Purge uses the Trane<sup>®</sup> CH530 control system. The system architecture distributes its electronics to the lowest possible level to maximize the ease of maintenance and troubleshooting and minimize the cost of any repairs.

The main elements of the EarthWise CH530 Purge control system are:

**DynaView - Main Processor**—The main processor resides in the DynaView operator interface. On a factory-installed unit mounted EarthWise Purge the DynaView operator interface is mounted on the face of the chiller control panel and is used to interface with the chiller as well as the purge. On a field installed or retrofit EarthWise Purge the DynaView operator interface is mounted on the purge itself, or it may be removed and mounted remotely. On a retrofit EarthWise Purge application where the chiller does not have CH530 controls the DynaView interfaces with the purge only.

**LLIDs**—Communicating with the main processor in the DynaView are several “Low Level Intelligent devices” or “LLIDs.” The LLIDs used by the EarthWise Purge consist of:

Temperature sensor LLIDs:

**Compressor Suction Temp Sensor.** This sensor is mounted on the purge condensing unit suction line and is used to provide feedback to the pumpout control algorithm used in making decisions on whether or not to purge non-condensables from the purge tank.

**Purge Liquid Temperature Sensor.** On factory installed purges the sensor used is the chiller’s saturated condenser temperature sensor LLID if the chiller is running, or the saturated evaporator temperature sensor LLID if the chiller is off. On field installed retrofit purges a LLID sensor is installed on the purge liquid drain line. The controls use this temperature sensor’s value to adjust the purge pumpout initiate/ terminate setpoints, and it may be used to prohibit pumpout if system conditions are too cool.

**Carbon Tank Temperature Sensor.** A temperature sensing LLID is installed in the carbon tank of the Purifier Purge and is used to provide feedback to the carbon regeneration algorithm. The sensor and the controls function much the same as a thermostat to control the carbon tank heater.

**Liquid Level Switch LLID.** This LLID resides in the purge control panel and monitors the status of the normally closed float switch that is mounted in the bottom of the purge tank. If liquid fails to correctly drain from the purge tank this float switch and LLID will detect the condition and prevent further purge operation.

**Condensing Unit LLID.** This LLID resides in the purge control panel and uses a high capacity relay to control the operation of the purge condensing unit.

**Quad Relay LLID.** This LLID resides in the purge control panel. It has 4 relay outputs that are used to control the pumpout compressor, the carbon tank heater, the regeneration solenoid, and an alarm output.

**Dual Triac LLID.** This LLID resides in the purge control panel. It has two triac type outputs that are used to control the pumpout solenoid valve and the exhaust solenoid valve.

CH530 EarthWise Purges that are factory mounted on a chiller will draw their control power from the power supplies of the chiller control panel. CH530 EarthWise Purges that are retrofit applications will have their own control power supply mounted in the purge control panel. EarthWise Purges that are 50 Hz applications will have a separate voltage correction transformer as well.

**IPC3 Bus:** The IPC3 Bus is the communication link between the components of the CH530 equipped EarthWise Purge. The IPC3 Bus protocol is based on RS485 signal technology and communicates at 19.2Kbaud.

The DynaView provides IPC3 bus management. It has the task of restarting the link when the normal communication has been degraded. Most purge diagnostics are handled by the DynaView. If a parameter is reported out of range by a LLID, the DynaView processes this information and calls out the diagnostic. The individual LLIDs are not responsible for any diagnostic functions.



## Electrical

---

Much of the purge setup, operation, and troubleshooting can be accomplished using the DynaView interface with the CH530. However, more advanced functions will require the use of lap-top based TechView interface software. For information regarding the use of TechView with the EarthWise Purge, refer to the appropriate TechView material at [www.trane.com](http://www.trane.com).

# 2309-8046A Connection Diagram

## CH530 Factory unit wiring, factory-installed standard Purge control panel

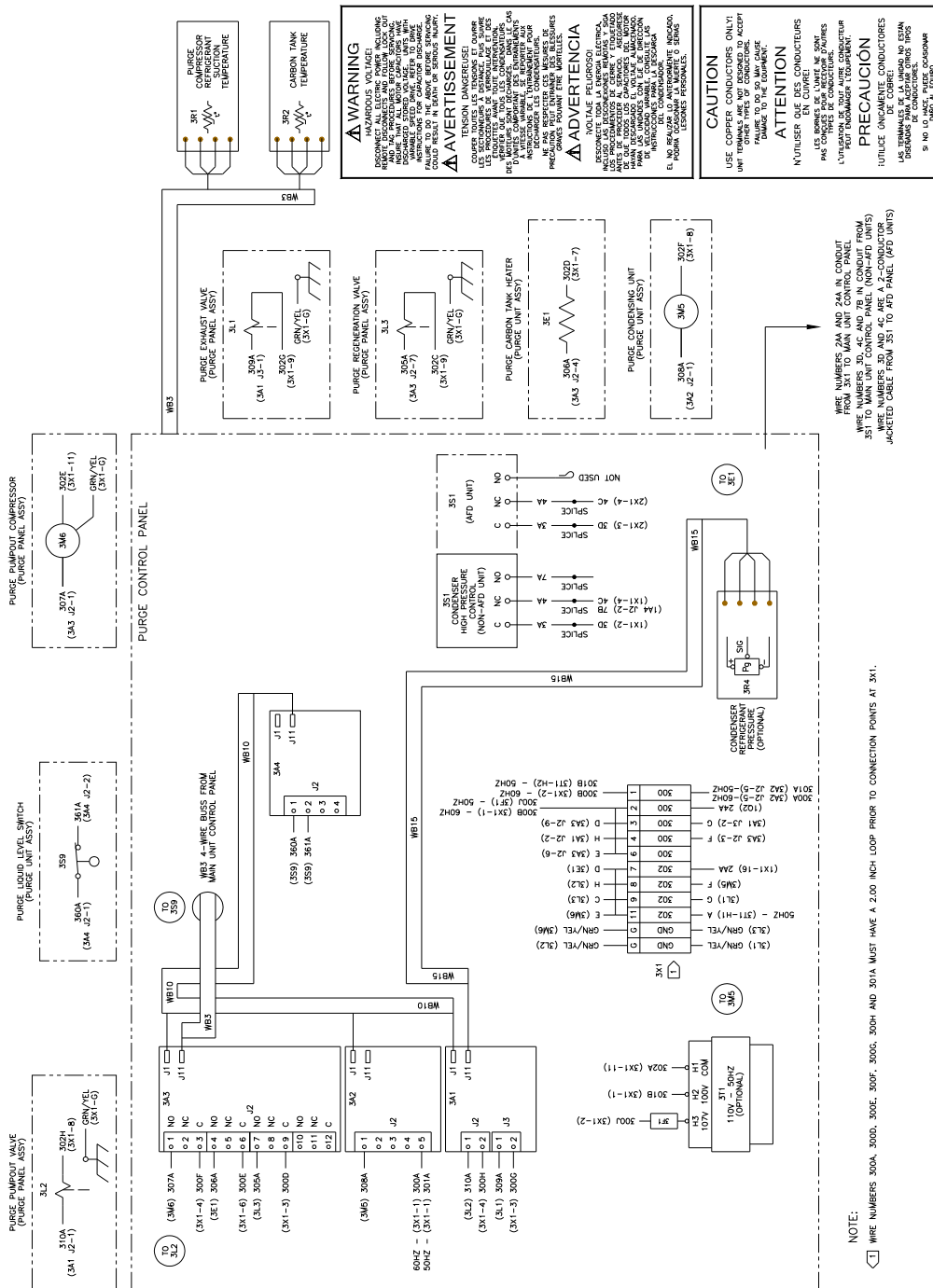

# 2309-8047A Connection Diagram

## CH530 Factory unit wiring, factory-installed Industrial Purge control panel

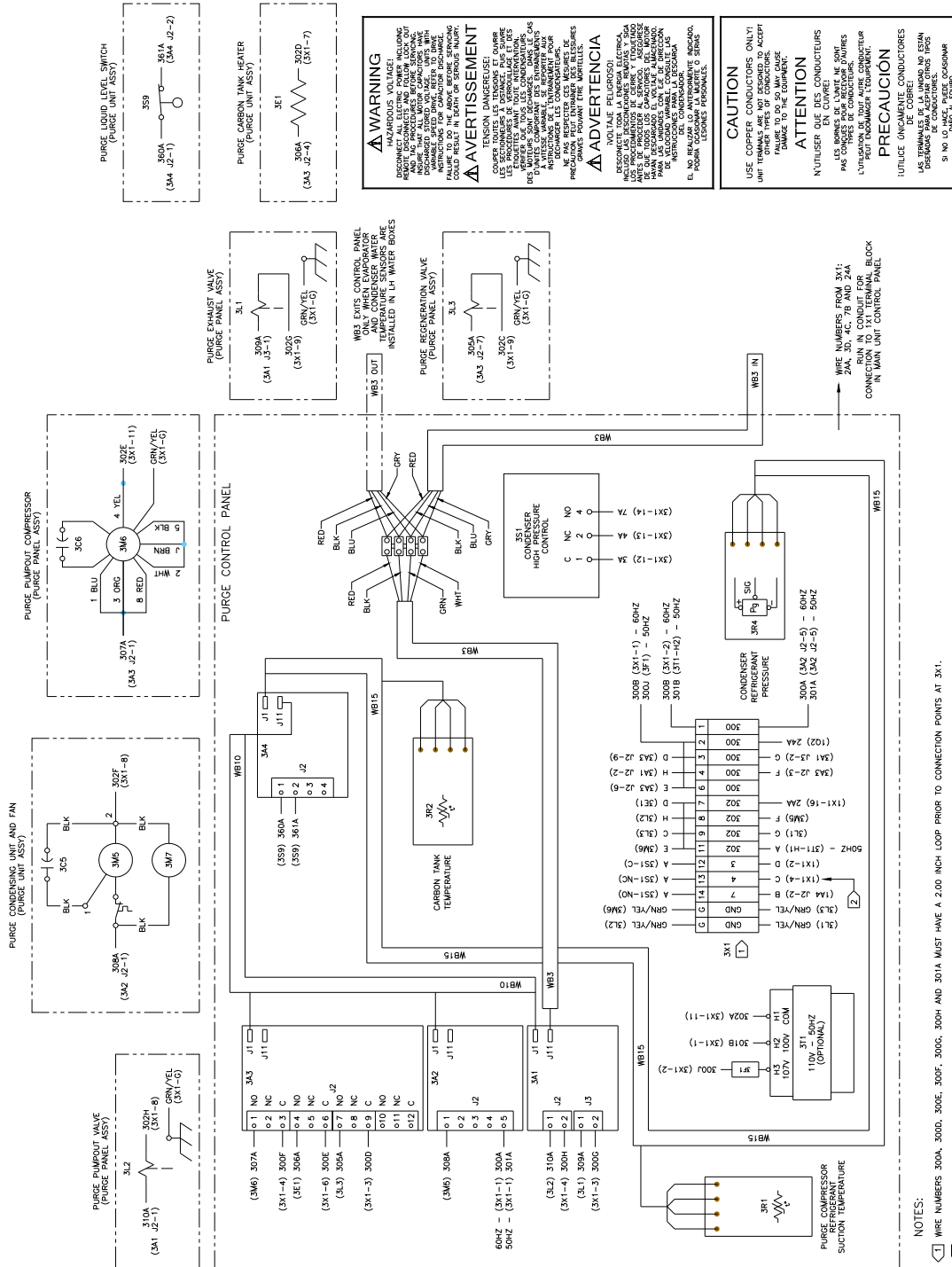

**⚠ WARNING**  
 DESCONNECT ALL ELECTRICAL POWER INCLUDING MAIN LINE POWER BEFORE WORKING ON THIS WIRING. ALWAYS USE THE CORRECT WIRING TECHNIQUES FOR CAPACITOR DISCHARGE. FAILURE TO DO SO MAY CAUSE PERSONAL INJURY OR DEATH.

**⚠ AVERTISSEMENT**  
 COUPER TOUTES LES TENSIONS ET AJOURNER LES PROTECTEURS DE LA BOUCHE AVANT DE TRAVAILLER SUR LE CÂBLAGE. TOUJOURS UTILISER LES TECHNIQUES APPROPRIÉES POUR LA DÉCHARGES DES CONDENSATEURS. LE MANQUE DE PRÉCAUTION PEUT CAUSER DES BLESSURES PERSONNELLES.

**⚠ ADVERTENCIA**  
 NO LEA PELIGROSO!  
 DESCONECTE TODAS LAS TENSIONES Y AJUSTE LOS PROTECTORES ANTES DE TRABAJAR EN EL CABLEADO. SIEMPRE UTILICE LAS TÉCNICAS CORRECTAS PARA LA DESCARGA DE LOS CONDENSADORES. EL MANQUE DE PRECAUCIONES PUEDE CAUSAR LESIONES PERSONALES.

**CAUTION**  
 USE COPPER CONDUCTORS ONLY!  
 UNIT TERMINALS MUST BE PROPERLY ACCEPTED BY THE WIRING TYPES OF CONDUCTORS. FAILURE TO DO SO MAY CAUSE PERSONAL INJURY OR DEATH.

**ATTENTION**  
 N'UTILISER QUE DES CONDUCTEURS EN LAITON!  
 LES BORNES DE L'UNITÉ NE SONT PAS CONÇUES POUR ACCEPTER D'AUTRES TYPES DE CONDUCTEURS. LE MANQUE DE PRÉCAUTION PEUT CAUSER DES BLESSURES PERSONNELLES.

**PRECAUCION**  
 UTILICE UNICAMENTE CONDUCTORES DE COBRE.  
 LAS TERMINALES DE LA UNIDAD NO ESTÁN DISEÑADAS PARA ACEPTAR OTROS TIPOS DE CONDUCTORES. SI NO SE USAN LOS TIPOS CORRECTOS DE CONDUCTORES, SE PUEDE CAUSAR LESIONES PERSONALES.

**NOTES:**  
 1 WIRE NUMBERS 300A, 300D, 300E, 300F, 300G, 300H AND 301A MUST HAVE A 2.00 INCH LOOP PRIOR TO CONNECTION POINTS AT 3X1.  
 2 WIRE 4C CONNECTS TO 1X1-18 WHEN OPTIONAL SMP IS PRESENT ON UNIT.



## 2309-8041D CH530 Schematic Wiring

### CH530 Schematic wiring diagram, Simplex or Duplex unit, factory-installed standard, NEMA 4 or Industrial Purge

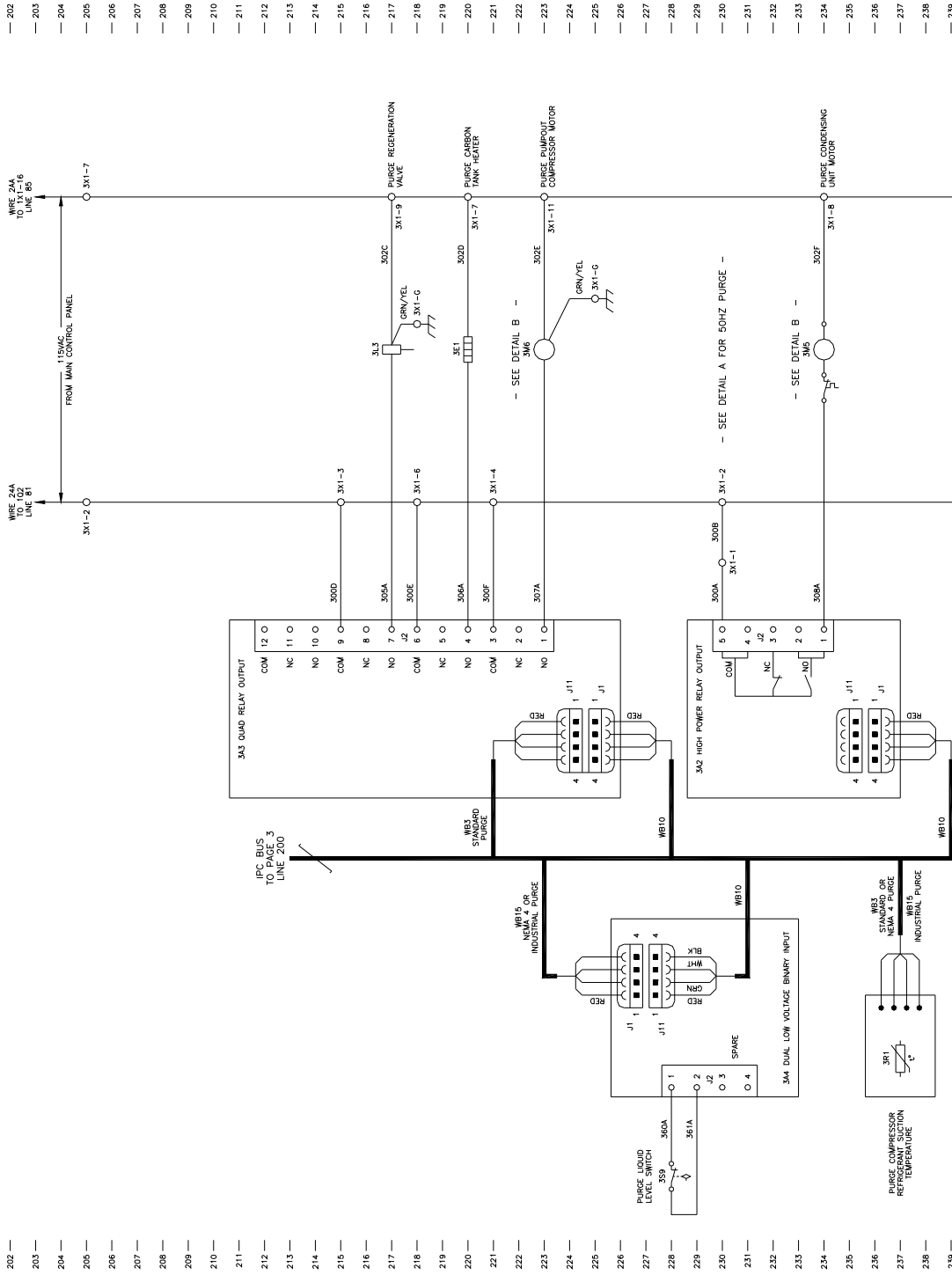

## 2309-8041D CH530 Schematic Wiring (continued)

### CH530 Schematic wiring diagram, Simplex or Duplex unit, factory-installed standard, NEMA 4 or Industrial Purge

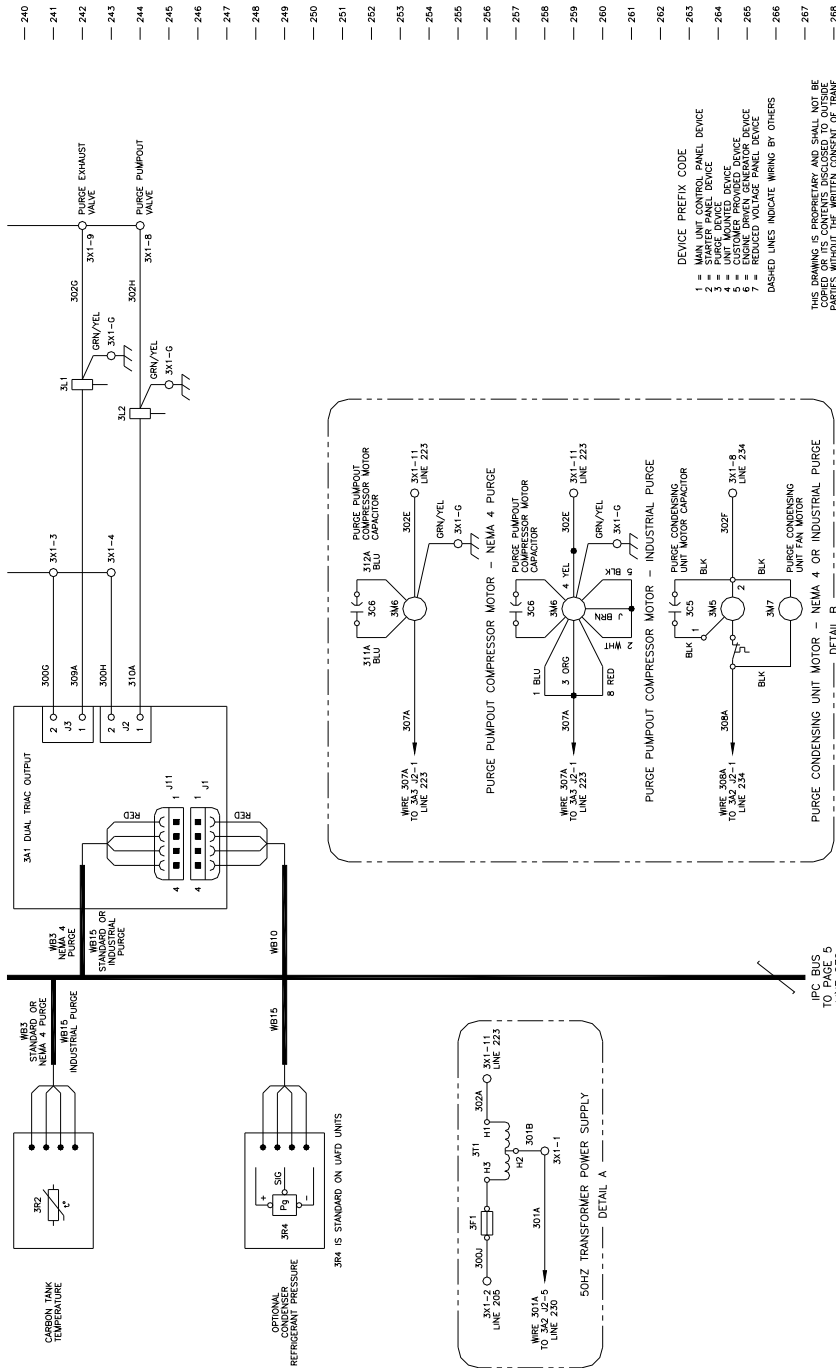

- DEVICE PREFIX CODE
- 1 = MAIN UNIT CONTROL PANEL DEVICE
  - 2 = STARTER PANEL DEVICE
  - 3 = UNIT MOUNTED DEVICE
  - 4 = CUSTOMER PROVIDED DEVICE
  - 5 = REDUCED VOLTAGE PANEL DEVICE
  - 7 = REDUCED VOLTAGE PANEL DEVICE
- DASHED LINES INDICATE WIRING BY OTHERS

THIS DRAWING IS SUPERSEDED BY THE FINAL UNIT BE  
 CUP-ED PARTS LIST. CONTACTS DISCLOSED TO OHSBE  
 PARTS WITHOUT THE WRITTEN CONSENT OF TRANE

|   |   |
|---|---|
| <p><b>WARNING</b></p> <p>HAZARDOUS VOLTAGE!</p> <p>DISCONNECT ALL ELECTRIC POWER INCLUDING MAIN POWER SUPPLY BEFORE SERVICING AND TAG PROCEDURES BEFORE SERVICING DISCHARGED STORED VOLTAGE UNITS WITH INSTRUCTIONS FOR CAPACITOR DISCHARGE.</p> <p>FAILURE TO DO THE ABOVE BEFORE SERVICING COULD RESULT IN DEATH OR SERIOUS INJURY.</p> | <p><b>AVERTISSEMENT</b></p> <p>TENSION DANGEREUSE!</p> <p>COUPPEZ TOUTES LES TENSIONS ET FOURRIS LES UNITÉS AVANT DE RÉPARER. ÉTIQUETTES LES PROCÉDURES DE VERROUILLAGE ET DES DISCHARGES DES UNITÉS À TENSION RÉDUITE. SUIVEZ LES INSTRUCTIONS POUR LA DÉCHARGE DES CONDENSATEURS.</p> <p>LE NON-RESPECT DES MESURES DE SÉCURITÉ POUVANT ÊTRE MORTELLES.</p>   |
| <p><b>CAUTION</b></p> <p>USE COPPER CONDUCTORS ONLY!</p> <p>UNIT TERMINALS USE NOT DESIGNED TO ACCEPT OTHER TYPES OF CONDUCTORS.</p> <p>FAILURE TO USE SA LINK CALIBRE CAN CAUSE DAMAGE TO THE EQUIPMENT.</p>   | <p><b>PRECAUCIÓN</b></p> <p>UTILICE ÚNICAMENTE CONDUCTORES DE COBRE!</p> <p>LOS TERMINALES DE LOS UNITS NO SON DISEÑADOS PARA ACEPTAR OTROS TIPOS DE CONDUCTORES.</p> <p>SI NO SE USAN CALIBRE DE COBRE, SE PUEDE DAÑAR EL EQUIPO.</p>  |
| <p><b>ATTENTION</b></p> <p>N'UTILISER QUE DES CONDUCTEURS EN COPRE!</p> <p>LES TERMINALES DES UNITS NE SONT PAS CONÇUES POUR RECEVOIR D'AUTRES TYPES DE CONDUCTEURS.</p> <p>L'USAGE D'UN CALIBRE INAPPRÉPRIÉ PEUT ENDOMMAGER L'ÉQUIPEMENT.</p>  | <p><b>ADVERTENCIA</b></p> <p>¡VOLTAGE PELIGROSO!</p> <p>DESCONECTE TODA LA ENERGÍA ELÉCTRICA ANTES DE REPARAR. ETIQUETE Y ETIQUETEE LOS PROCEDIMIENTOS DE CERRAJE Y ETIQUETADO DE QUE TODOS LOS CONDENSADORES DEL MOTOR DEBE SER DISCHARGADOS ANTES DE SER REPARADOS. SIGA LAS INSTRUCCIONES PARA LAS UNIDADES A TENSION REDUCIDA.</p> <p>EL NO REALIZAR LO ANTERIORMENTE MENCIONADO, PUEDE CAUSAR LESIONES PERSONALES.</p> |

## 2309-8042C CH530 Schematic Wiring

### CH530 Schematic wiring diagram, Simplex or Duplex unit, field-installed (Aftermarket) standard or NEMA 4 Purge

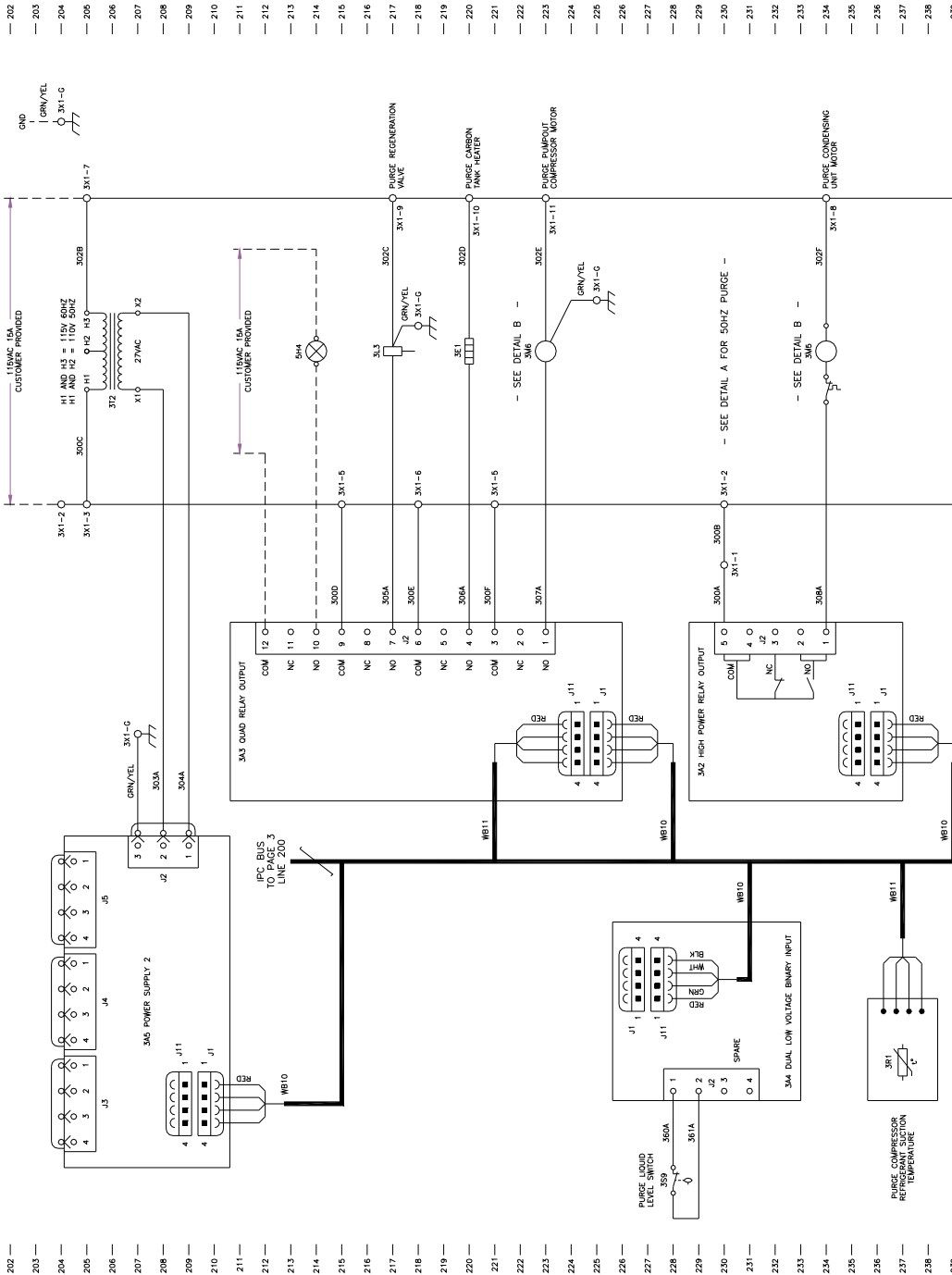

## 2309-8042C CH530 Schematic Wiring (continued)

### CH530 Schematic wiring diagram, Simplex or Duplex unit, field-installed (Aftermarket) standard or NEMA 4 Purge

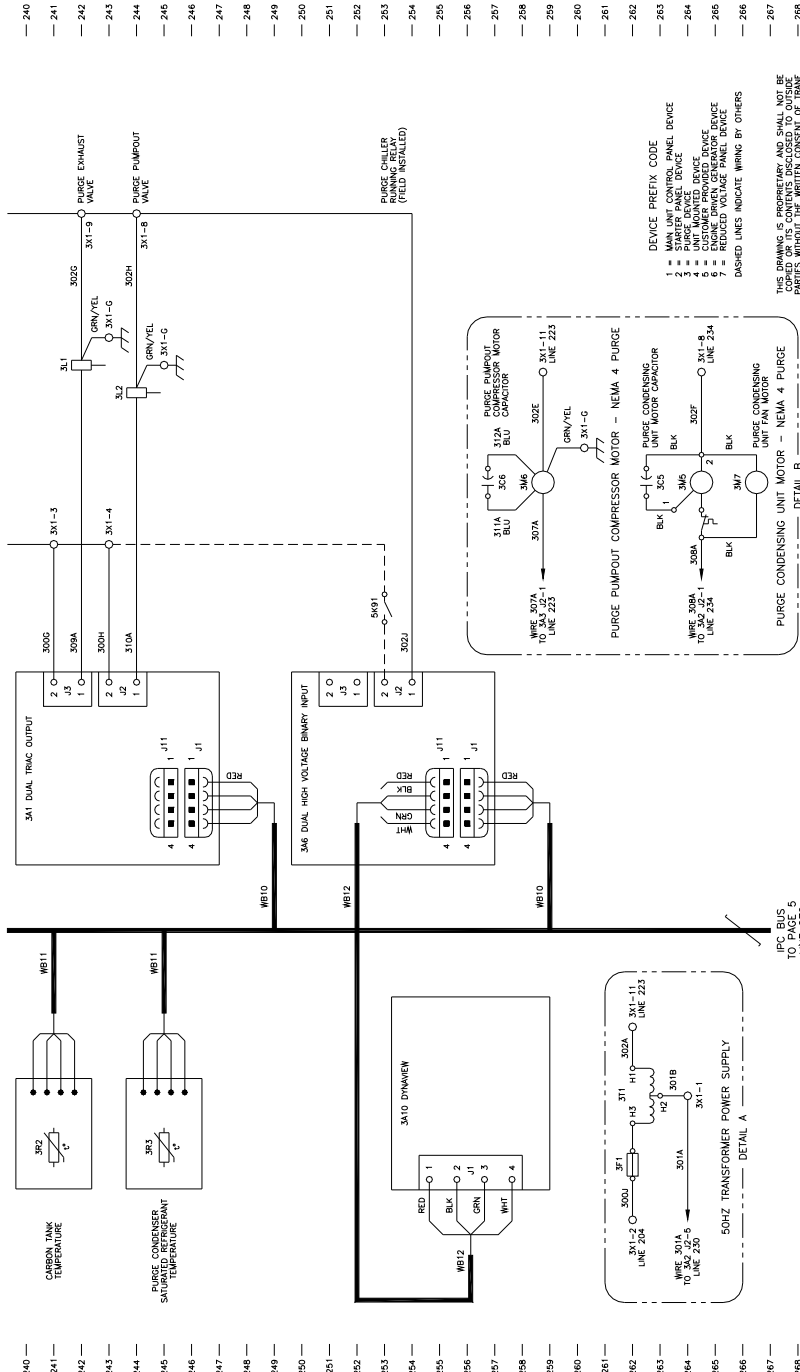

**CAUTION**  
USE COPPER CONDUCTORS ONLY!  
UNIT TERMINALS ARE NOT DESIGNED TO ACCEPT OTHER TYPES OF CONDUCTORS.  
FAILURE TO DO SO MAY CAUSE DAMAGE TO THE EQUIPMENT.

**ATTENTION**  
N'UTILISER QUE DES CONDUCTEURS EN CUIVRE!  
LES BORNES DE L'UNITÉ NE SONT PAS CONÇUES POUR ACCEPTER D'AUTRES AUTRES TYPES DE CONDUCTEURS.  
L'UTILISATION DE TOUT AUTRE CONDUCTEUR PEUT ENDOMMAGER L'ÉQUIPEMENT.

**PRECAUCIÓN**  
UTILICE ÚNICAMENTE CONDUCTORES DE COBRE!  
LAS TERMINALES DE LA UNIDAD NO ESTÁN DISEÑADAS PARA ACEPTAR OTROS TIPOS DE CONDUCTORES.  
SI NO LO HACE, PUEDE OCASIONAR DAÑO AL EQUIPO.

**WARNING**  
HAZARDOUS VOLTAGE!  
DISCONNECT AND FOLLOW LOCK OUT PROCEDURES BEFORE WORKING ON THIS EQUIPMENT. BE SURE THAT ALL MOTOR CAPACITORS HAVE BEEN DISCHARGED BEFORE WORKING ON ANY ELECTRICAL COMPONENTS. FAILURE TO FOLLOW THESE INSTRUCTIONS FOR CAPACITOR DISCHARGE COULD RESULT IN DEATH OR SERIOUS INJURY. PRECAUTION: FOLLOW ALL WARNINGS AND LABELS.

**AVERTISSEMENT**  
TENSION DANGEREUSE!  
COUPUREZ LA SOURCE D'ÉNERGIE ÉLECTRIQUE ET SUIVEZ LES PROCÉDURES DE VERIFICATION DE LA TENSION AVANT DE TRAVAILLER SUR L'ÉQUIPEMENT. VEILLER À CE QUE TOUS LES CONDENSATEURS DE MOTEUR AIENT ÉTÉ DÉCHARGÉS AVANT DE TRAVAILLER SUR LES COMPOSANTS ÉLECTRIQUES. LE NON-RESPECT DE CES MESURES DE PRÉCAUTION PEUT CAUSER LA MORT OU DES BLESSURES GRAVES. SUIVEZ TOUJOURS LES AVERTISSEMENTS ET ÉTIQUETTES.

**ADVERTENCIA**  
¡VOLTAJE PELIGROSO!  
DESCONECTE LAS BORNAS DE LA UNIDAD Y SIGA LAS PROCEDURAS DE VERIFICACIÓN DE LA TENSION ANTES DE PROCEDER AL SERVICIO. ASEGURESE DE QUE TODOS LOS CONDENSADORES DE MOTOR HAYAN DESCARGADO EL VOLTAJE ALMACENADO ANTES DE TRABAJAR EN CUALQUIER COMPONENTE ELÉCTRICO. EL NO REALIZAR LO ANTERIORMENTE INDICADO, PODRÍA CAUSAR LA MUERTE O LESIONES PERSONALES.



[www.trane.com](http://www.trane.com)

For more information, contact your local Trane office or e-mail us at [comfort@trane.com](mailto:comfort@trane.com)

---

|                         |                             |
|-------------------------|-----------------------------|
| Literature Order Number | PRGD-SVU01C-EN              |
| Date                    | July 2010                   |
| Supersedes              | PRGD-SVU01C-EN (April 2006) |

---

Trane has a policy of continuous product and product data improvement and reserves the right to change design and specifications without notice. Only qualified technicians should perform the installation and servicing of equipment referred to in this literature.