



TRANE®

Installation, Operation, and Maintenance Guide

Industrial Chiller Package

*for Water-Cooled CenTraVac™ Chillers with
Tracer AdaptiView™ Control*

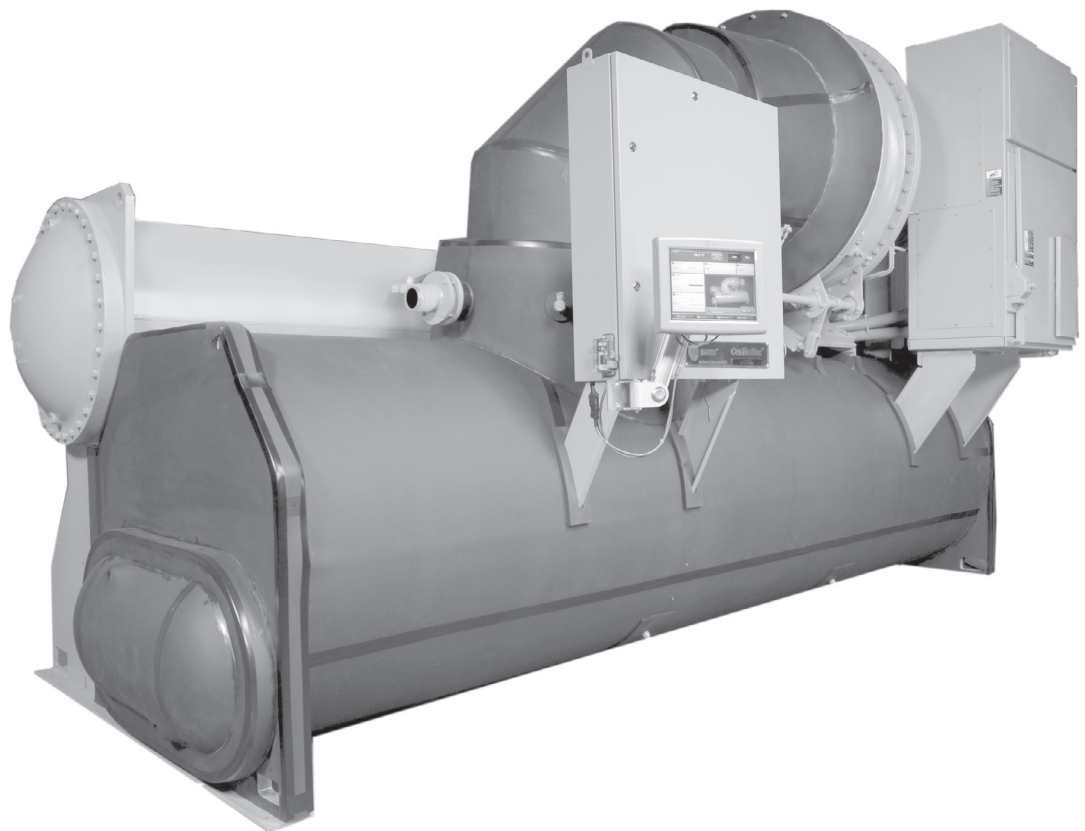

January 2008

X39641073-01 A

CTV-SVX07A-EN

Copyright

© 2008 Trane All rights reserved

This document and the information in it are the property of Trane and may not be used or reproduced in whole or in part, without the written permission of Trane. Trane reserves the right to revise this publication at any time and to make changes to its content without obligation to notify any person of such revision or change.

Trademarks

Trane and the Trane logo are trademarks of Trane in the United States and other countries. All trademarks referenced in this document are the trademarks of their respective owners.

Warnings and cautions

Warnings and cautions are provided in appropriate places throughout this document:

 **WARNING:** Indicates a potentially hazardous situation which, if not avoided, could result in death or serious injury.

 **CAUTION:** Indicates a potentially hazardous situation which, if not avoided, may result in minor or moderate injury. It may also be used to alert against unsafe practices.

CAUTION: Indicates a situation that may result in equipment or property-damage only accidents.

Contents

| | |
|---|----|
| Overview | 4 |
| Installation, operation, and maintenance | 4 |
| Control panel | 4 |
| Purge | 6 |
| Sensors and transducers | 8 |
| Machine bus (M-bus) | 8 |
| INDP options | 9 |
| Control power transformer (CPTR) | 9 |
| Supplemental motor protection (SMP) | 10 |
| Surge Capacitors | 11 |
| Lightning arrestors | 12 |
| Zero-sequence ground fault | 12 |
| Current transformers | 12 |
| SMP installation | 13 |
| Limited access installation | 13 |
| Inspection | 14 |
| Maintenance | 14 |
| Differential motor protection (DMP) | 15 |
| SEPAM module display | 16 |
| Default SEPAM parameter settings for the Trane application | 17 |
| Default SEPAM protection settings for the Trane application | 19 |
| Industrial Terminal Block | 20 |
| Three-Pole Disconnect | 21 |
| Secondary PTs | 21 |
| Current Transformers | 21 |
| Vacuum Circuit Breaker (CVAC) | 21 |



Overview

This guide provides directions for installing an Industrial Package (INDP) on a CenTraVac chiller.

CenTraVac chillers that are equipped with an INDP have the following features:

- Enclosed wiring in seal-tight conduits and junction boxes
- An industrial-grade control panel
- An up-graded purge
- The entire chiller is silicone free

Installation, operation, and maintenance

General installation, operation, and maintenance of an INDP-equipped CenTraVac chiller, are the same as that of a standard CenTraVac. Refer to the latest revision of the Installation, Operation, and Maintenance manual shipped with the CenTraVac chiller.

Note: The INDP-equipped chiller is available with several options that may affect control, power, and starter wiring connections. Refer to "INDP options," p. 9 for further details regarding available options.

Control panel

The control panel enclosure provided on INDP-equipped chillers is of oversized NEMA 4 construction. The door of the control panel is secured in place by four latch assemblies that can be released with a straight blade screwdriver. The top of the control panel contains three removable panels that are provided for the termination of the customer's wiring conduits to and from the control panel. The Tracer UC800 controller is also mounted on DIN rails inside the panel.

To install a conduit onto the control panel:

1. Remove the panel from the enclosure.
2. Drill the conduit connection holes into the panel.
3. Re-install the panel onto the enclosure.

Follow steps 1-3 above to prevent debris from entering the enclosure. Screw-type terminal blocks are provided to ensure secure customer and unit control wiring connections.

[Figure 1, p. 5](#) shows all standard and optional controls in their mounting locations inside the control panel. [Table 1, p. 5](#) provides a description for each termination.

Figure 1. Control panel layout

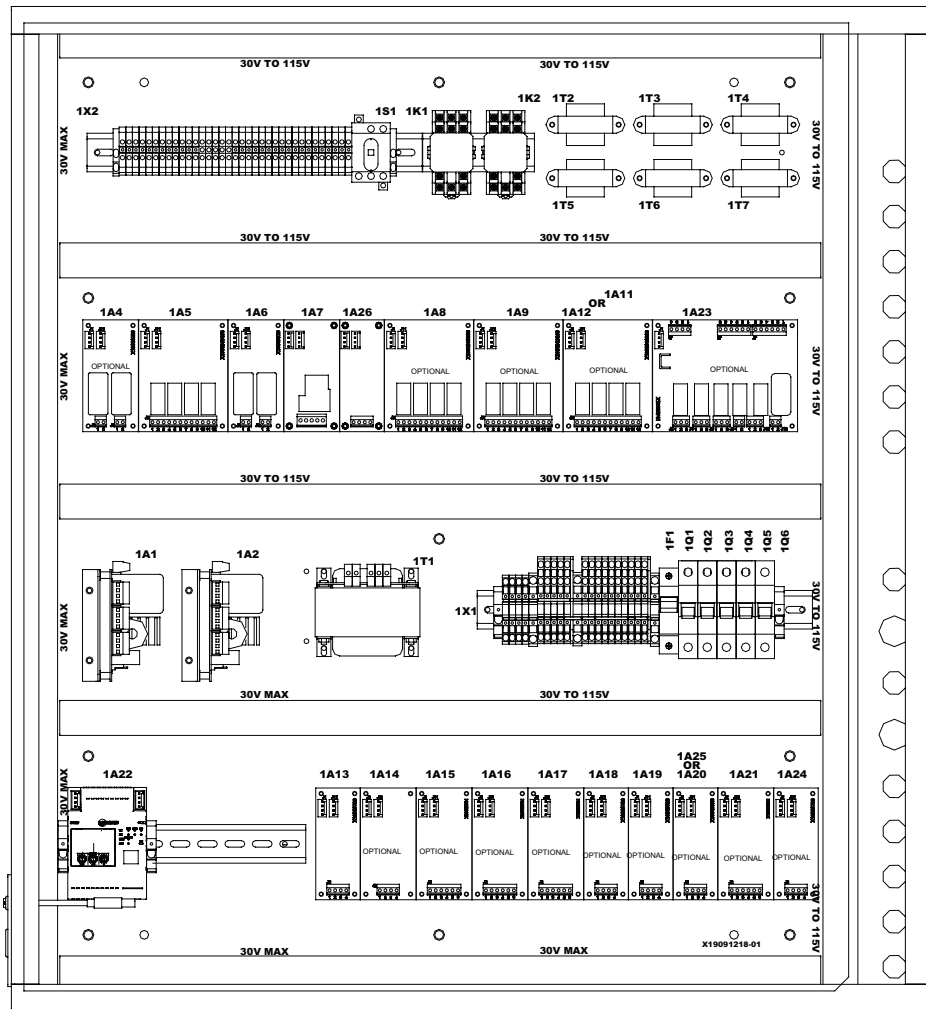

Table 1. Control panel key

| Wiring terminal location number | Description | Option (note) |
|---------------------------------|--|-------------------|
| 1X2 | Control panel terminal block, customer connection | |
| 1A24 | Starter fault input | Optional (11) |
| 1A22 | UC800 controller | |
| 1A21 | Evap and water | Optional (6) |
| 1A20 | External free cooling command and valve status inputs | Optional (12) |
| 1A19 | External ice building command input | Optional (12) |
| 1A18 | External base load and hot water enable/disable inputs | Optional (12) |
| 1A17 | External base load and refrigerant monitor inputs | Optional (12) |
| 1A16 | External current limit and chilled water setpoint inputs | Optional (2) |
| 1A15 | % RLA and cond press outputs (2-10vdc) | Optional (2 or 3) |

Table 1. Control panel key (continued)

| Wiring terminal location number | Description | Option (note) |
|---------------------------------|---|-------------------|
| 1A14 | Comm 4 or comm 5 module | Optional (4 or 5) |
| 1A13 | External auto/stop and emerg stop inputs | |
| 1A23 | Starter module | Optional (8) |
| 1A11 | Free cooling output | Optional (12) |
| 1A12 | Hot gas Bypass output | Optional (12) |
| 1A9 | 1A9 Chiller Status outputs | Optional (1) |
| 1A8 | 1A8 Chiller Status outputs | Optional (1) |
| 1A7 | 1A7 Oil/Ref Pump Motor control relay | |
| 1T2 | Secondary PT | Optional (8) |
| 1T3 | Secondary PT | Optional (8) |
| 1T4 | Secondary PT | Optional (8) |
| 1K1 | Vac Circuit Breaker control relay | Optional (9) |
| 1K2 | Vac Circuit Breaker control relay | Optional (9) |
| 1A26 | Motor Winding Temp inputs | |
| 1A6 | Cond & Evap flow switch/interlock inputs | |
| 1A5 | Cond & Evap wtr pump and oil heater outputs | |
| 1A4 | Cond High Press Sw Input | |
| 1T1 | Control Power Transformer | |
| 1A1 | 24 Vdc Power Supply #1 | |
| 1A2 | 24 Vdc Power Supply #2 | Optional (13) |
| 1X1 | Control Panel Terminal Block | |
| 1S1 | 3-Pole Disconnect | Optional (10) |

Option Notes:

1. OPST Operating Status Option
2. GBAS Generic BAS Option
3. CDRP Condenser Refrigerant Pressure Option
4. TRM4 Tracer Communications Interface
5. TRM5 LonTalk Communications Interface
6. WPSR Variable Flow Compensation
7. EPRO Enhanced Protection
8. Starter By Others
9. Starter By Others with CVAC starter type
10. Starter By Others with line voltage greater than 600 Vac
11. With SSS starter type
12. Only present if the corresponding HGBP, FC, or Base Load option is applied
13. As determined by 24 Vdc load requirement

Purge

The purge unit provided on an INDP-equipped chiller is designed with the following attributes:

- A NEMA 4 enclosure
- Sealed conduits
- A sealed purge compressor motor terminal box
- A totally enclosed fan-cooled (TEFC) pump-out motor that drives an open-type pump-out compressor

The purge control panel houses:

- The purge suction temperature and carbon tank sensor LLIDs (3R1 and 3R2).
- The condenser refrigerant pressure transducer (3R4).
- A screw-type terminal block (which replaces the spring clamp terminal strip used previously).

The 1/12 hp, 115 V, 2.2 A TEFC pump-out motor of the INDP purge has a side-mounted thermal protector that requires a manual reset if tripped. If a thermal trip occurs, reset it after the motor cools by pressing the red button on the side of the motor shell. A “click” indicates reset.

Purge operation and maintenance on INDP-equipped chillers is the same as on standard chillers. (Refer to the latest revision of Earthwise Purge Operation and Maintenance manual, *PRGD-SVU02-EN*.) [Figure 2](#) shows the termination locations inside the purge control panel. [Table 2, p. 7](#) provides a description for each termination shown in [Figure 2](#).

Figure 2. Purge control panel

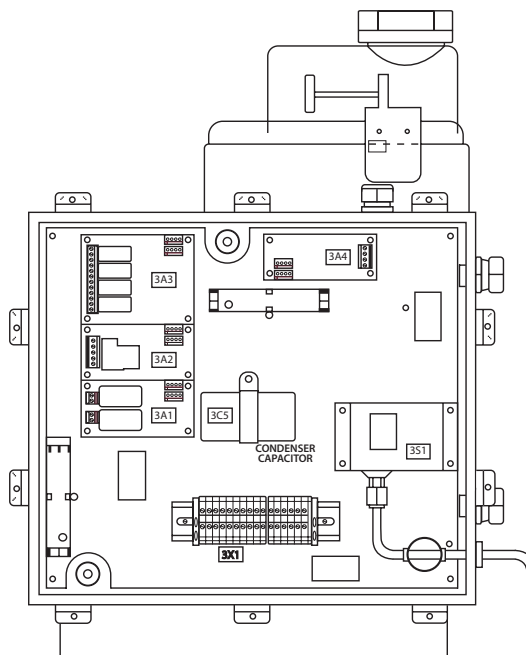

Table 2. Termination descriptions

| Number | Description |
|--------|---|
| 3A1 | Purge Pumpout and Exhaust Valve Control LLID |
| 3A2 | Purge Condensing Unit Control Relay LLID |
| 3A3 | Purge Pumpout, Carbon Tank Heater, Regeneration Valve, and Alarm Relay LLID |
| 3A4 | Purge Liquid Level Switch Input LLID |
| 3C5 | Purge Condensing Unit Capacitor |

Table 2. Termination descriptions (continued)

| Number | Description |
|--------|---|
| 3M6 | Purge Pumpout Compressor Motor |
| 3R1 | Purge Refrigerant Compressor Suction Temperature Sensor |
| 3R2 | Purge Carbon Tank Temperature Sensor |
| 3R4 | Condenser Pressure Transducer |
| 3S1 | Condenser High Pressure Cutout Switch |
| 3X1 | Purge Panel Terminal Block |

Sensors and transducers

On INDP-equipped chillers, if the system temperature and pressure sensors are not contained within a control panel, they are mounted inside sealed polycarbonate boxes. The diagram designator for the device inside a box is indicated on a permanent label affixed to the box. The larger polycarbonate box mounted on the face of the oil sump contains the oil sump temperature sensor (4R5) and the oil sump pressure transducer (4R4).

The Machine bus (M-bus) enters into the box and is connected to the device using automotive-type plug-in connectors. If necessary, it is connected (using another similar connector) to the M-bus leaving the box to go to the next device. The cover of the box is clear so you can see the LLID LED during binding and troubleshooting. In most cases, the magnet-activated LLID binding switch is accessible by loosening the four captive screws that secure the cover to the box.

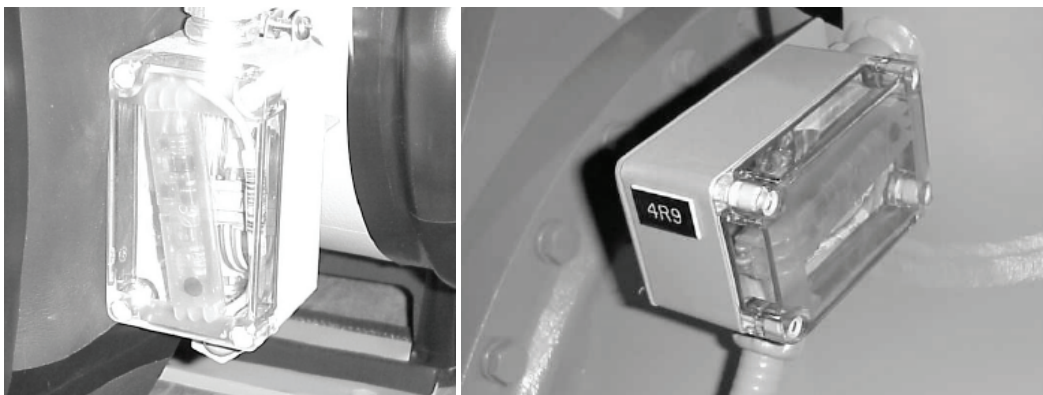
Figure 3. Typical photographs of a temperature sensor/polycarbonate box

Machine bus (M-bus)

The UC800 comm/24 Vdc bus wire on INDP-equipped chillers runs within sealed conduits with all junctions occurring in unit control panels or in the polycarbonate device boxes. No junctions or splices exist inside the conduits. To service or troubleshoot the Machine bus on the chiller frame, access it through the device boxes.

INDP options

Control power transformer (CPTR)

The CPTR consists of a unit-mounted, factory-wired enclosure that contains a 4 kva, 480 V/120 V control power transformer (4T5). This option is used when customers want the chiller control power provided by an alternate source. The CPTR has a disconnect switch (4S1), and primary and secondary fuses are installed (see [Figure 4](#) and [Table 3](#)).

Figure 4. CPTR interior

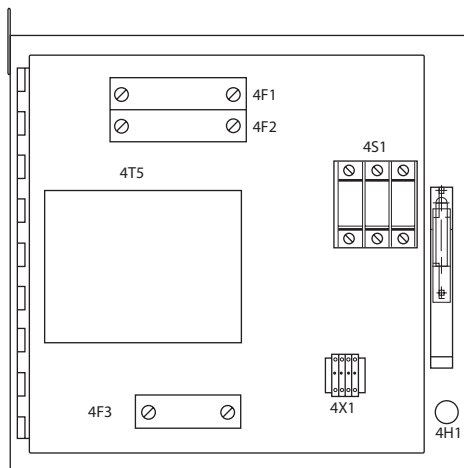

Table 3. Control power transformer CPTR (option)

| Device Designation | Description |
|--------------------|-------------------------------|
| 4S1 | Disconnect switch |
| 4H1 | Light |
| 4X1 | Terminal block, 40 A, 600 V |
| 4F1, 4F2 | 600 V fuse, Class RK5, TRS10R |
| 4F3 | 250 V fuse, Class R5K, TR40R |
| 4T1 | 4 kva transformer, 480:120 |

A fuse status indicator light (4H1) is provided for the secondary fuse. Light 4H1 is illuminated when power is on and the secondary fuse is intact. Light 4H1 is off when the main power is off or if the secondary fuse has opened.

⚠ WARNING**Hazardous Voltage w/Capacitors!**

Disconnect all electric power, including remote disconnects and discharge all motor start/run capacitors before servicing. Follow proper lockout/tagout procedures to ensure the power cannot be inadvertently energized. For variable frequency drives or other energy storing components provided by Trane or others, refer to the appropriate manufacturer's literature for allowable waiting periods for discharge of capacitors. Verify with an appropriate voltmeter that all capacitors have discharged. Failure to disconnect power and discharge capacitors before servicing could result in death or serious injury.

The door latch of the CPTR is interlocked with the disconnect switch. To open the CPTR panel, first open the disconnect switch by applying light upward pressure to the release trigger on the door latch while using a flat bladed screwdriver or other similar tool to unlock the door latch.

The primary fuses (4F1 and 4F2) are 10 A, 600 V, Class RK5.

The secondary fuse (4F3) is 40 A, 250 V, Class RK5.

The approximate weight of the CPTR is 120 lbs (55 kg).

During the installation of a chiller equipped with the CPTR option, the installer must provide 460-480 Vac, 20 A, 3-phase power to the L1, L2, and L3 (only 2 phases are used L1 & L3, single phase transformer) connections of the disconnect switch (4S1). The input power should be from a source that is separate from the main chiller power supply.

The incoming power conduit provided by the installer should be connected to the CPTR enclosure on the top right side, at a position above the disconnect switch. Do not contaminate the enclosure while drilling or cutting conduit access holes.

The disconnect switch accepts #14 to #4 incoming wire sizes. The incoming wire must be copper and must be rated for a minimum of 90C. Torque the incoming wire connections at the disconnect to 55 lb-in (6.2 Nm).

A ground lug is available in the CPTR enclosure and must be torqued to 35 lb-in (4 Nm).

Refer to [Figure 4, p. 9](#), CPTR Interior and to the CPTR wiring diagram.

Supplemental motor protection (SMP)

SMP is available on INDP-equipped chillers with medium voltage motors. SMP is factory-installed and wired in an enclosure that is mounted directly on the motor terminal flange. SMP consists of Surge Capacitors, Lightning Arrestors, and a Zero-Sequence ground fault detector. Refer to [Figure 5, p. 11](#) and to the SMP wiring diagram.

Figure 5. SMP Interior

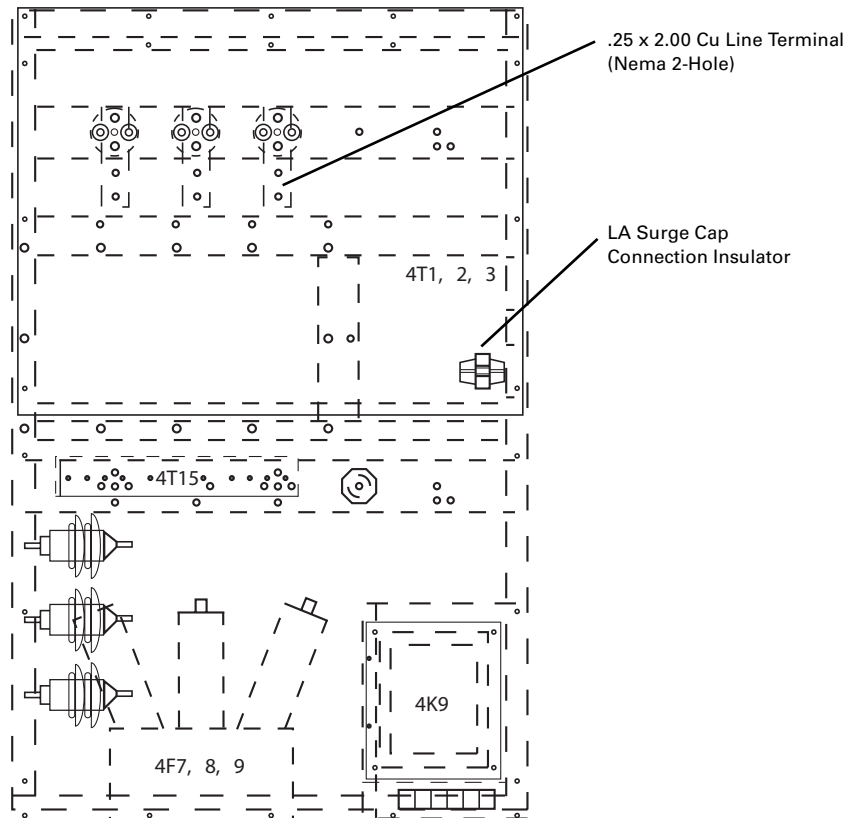

Surge Capacitors

The surge capacitors (4F7, 4F8, and 4F9) operate along with the lightning arrestors to provide electrical surge protection for the chiller motor.

WARNING

Hazardous Voltage w/Capacitors!

Disconnect all electric power, including remote disconnects and discharge all motor start/run capacitors before servicing. Follow proper lockout/tagout procedures to ensure the power cannot be inadvertently energized. For variable frequency drives or other energy storing components provided by Trane or others, refer to the appropriate manufacturer's literature for allowable waiting periods for discharge of capacitors. Verify with an appropriate voltmeter that all capacitors have discharged. Failure to disconnect power and discharge capacitors before servicing could result in death or serious injury.

Wait a minimum of five minutes for the internal discharge resistors to reduce the residual voltage. After five minutes, short the capacitor terminals to ground using an insulated stick or an equivalent device.

Failure to disconnect power and properly discharge capacitors can result in death or serious injury.

Internal discharge resistors are installed in the capacitors, which reduce the residual voltage to 50 volts or less within five minutes after removing power. However, after five minutes and before servicing the capacitor or the wiring in the SMP enclosure, use an insulated grounding stick, or an equivalent device, to short and ground the capacitor terminals.

Maintenance

Under normal service conditions no further maintenance is required during the life of the unit. However, in contaminated atmospheres, it may be necessary to periodically clean the bushings and connections to prevent inadvertent arc-over.

Lightning arrestors

The lightning arrestors (4F4, 4F5, and 4F6) provided in the SMP are plastic-coated, high-performance metal oxide varistors. They require no regular maintenance under normal service conditions. However, in contaminated atmospheres, it may be necessary to periodically clean the housings and connections.

Zero-sequence ground fault

The SMP's ground fault protection system is designed to protect electrical equipment from destructive ground faults. It is not sufficiently sensitive to protect personnel.

The system consists of a current transformer type sensor (4T15) and a solid-state ground fault relay (4K9).

All three phases of the compressor motor power are run through the sensor, any ground fault current is sensed and then passed on to the relay. The sensor provides a trip signal of 4 to 12 amps of ground fault current, the actual trip point of the relay will vary according to its setting. The factory default setting of the relay is "C", which provides a nominal trip at 7 amps of ground fault current. The response time based on 200% of nominal trip amps is about 240 ms.

Once tripped, the ground fault relay (4K9) interrupts the control power to the starter contactors, causing the contactors to open and remove the motor from the line.

For further information regarding the ground fault protection system refer to Cutler-Hammer document I.L. 16-220-3G1.

Current transformers

If the unit is equipped with SMP and is also a Starter By Others application, the SMP enclosure will contain factory-installed singlestage current transformers. These transformers are factory-wired and provide the current sensing needed by the UC800, the customer will not have to provide primary or secondary CTs for this purpose.

SMP installation

The SMP is factory-installed on the chiller. The following procedure assumes the chiller is new, has never been installed, and, therefore, has no electrical power connected.

The SMP enclosure has a removable access panel on top to accommodate field installation of incoming power conduits. To prevent contamination of the SMP enclosure, the installer should remove the panel before making conduit cutouts. After the cutouts are complete, re-install the panel onto the enclosure and connect the conduits to the enclosure.

Be sure to properly support and protect the wire or conduit as it enters the SMP enclosure. Do not allow the wire insulation to rub against sharp panel edges, which could cause abrasion.

After the power wiring to the SMP is installed, seal the wire entry into the SMP enclosure as well as possible to prevent dirt, debris, or moisture from entering.

Trane recommends using copper conductors to connect the 3- phase power supply from the starter to the SMP.

Make sure the incoming power wiring is properly phased, and, if using multiple conductors per phase, that each power supply conduit run to the SMP enclosure carries the correct number of conductors to ensure equal phase representation.

The incoming wire from the chiller starter is brought through the top of the SMP enclosure and terminated to the L1, L2, and L3 tabs provided. The tabs are 0.25" x 2" tinned copper, with two 7/16" holes provided for bolting wire lugs to the tabs. Grade 5, 3/8-16 steel hardware should be used to connect the lugs to the tabs. Carefully tighten each connecting bolt to 25 ft-lbs (34 Nm).

A copper bus for the incoming ground connection is provided in the left side of the SMP enclosure.

The lower right side of the SMP enclosure contains the low voltage control section and a control voltage terminal strip (4X1).

Limited access installation

If necessary, remove the SMP enclosure to gain additional clearance for unit rigging and installing. The following procedure assumes the chiller is new, has never been installed, and, therefore, has no electrical power connected.

1. At the compressor motor terminal lugs inside the SMP enclosure, mark/label and disconnect the power wiring between the SMP and the motor terminals.
2. Mark/label and disconnect the control wiring entering the SMP panel.
3. Disconnect the control wiring conduit from the SMP panel.
4. Remove the bolts securing the bottom of the SMP panel to the brackets on the evaporator.
5. Trane recommends using a forklift truck for moving the SMP panel away from the chiller. Position the truck so it is ready to take up the weight of the starter panel. The

SMP installation

panel weighs approximately 500 lbs. (227 Kg). The panel is heavy and must be adequately secured before moving. Use care to prevent the forks from damaging the enclosure or the enclosure finish.

If it is not possible to use a forklift truck, support and lift the SMP away from the chiller using the two lifting eyes located on the top of the SMP enclosure. The proper use of a spreader bar is required. The lifting force applied to the eyes must be vertical.

5. Loosen the bolts that secure the SMP enclosure to the flange on the motor. Steady the SMP as the retaining bolts are removed because the panel may tip forward.

WARNING! **Heavy Object!**

Use extreme care when moving and storing heavy components. The starter may tip if mishandled. Failure to use caution could result in death or serious injury.

6. Support the weight of the SMP panel with the forklift truck or hoist/lifting eyes and carefully remove the SMP panel from the chiller.
7. Store the SMP panel in a clean and dry location with ample air circulation and heat to prevent condensation from occurring. Always protect the SMP from dirt and moisture.
8. When ready, reassemble the SMP panel onto the chiller in the reverse order.

WARNING **Grounding Required!**

Follow proper local and state electrical code on requirements for grounding. Failure to follow code could result in death or serious injury.

Inspection

Prior to the initially energizing an SMP-equipped chiller, or after major chiller service that required access to the SMP panel, the commissioning technician must perform an inspection—this is required.

1. Inspect the SMP closely for damage that may have occurred during shipping or installation.
2. Check all hardware for correctness and tightness.
3. Use a vacuum cleaner to remove any loose dust, dirt, or debris (scraps of wire, tools, etc.) from the SMP enclosure.
4. Ensure no moisture is present in the SMP enclosure.
5. Ensure all panels, covers, arc shields, etc. are correctly in place. ALL SMP panel retaining screws and hardware must be correctly reinstalled prior to energizing the equipment.

Maintenance

Confirm and maintain the NEMA integrity of the SMP enclosure. Use a vacuum cleaner to clean the enclosure if needed. Ensure the SMP enclosure is maintained clean and dry.

WARNING

Hazardous Voltage w/Capacitors!

Disconnect all electric power, including remote disconnects and discharge all motor start/run capacitors before servicing. Follow proper lockout/tagout procedures to ensure the power cannot be inadvertently energized. For variable frequency drives or other energy storing components provided by Trane or others, refer to the appropriate manufacturer's literature for allowable waiting periods for discharge of capacitors. Verify with an appropriate voltmeter that all capacitors have discharged. Failure to disconnect power and discharge capacitors before servicing could result in death or serious injury.

At least annually, verify the power and control wiring and connection integrity. Inspect for loose joints that may produce excess heat and discolor or damage conductors. Verify the wire or cable insulation has not been damaged by high temperatures. Use care to not overtorque bolts while verifying tightness.

Differential motor protection (DMP)

Differential protection is used to detect internal faults in the motor windings, including ground faults, short circuits, and open circuits. Possible fault causes are damaged insulation due to aging, overheating, over-voltage, wet insulation, and mechanical damage. Trane uses the self-compensating method (one CT per motor winding)

If the DMP option is selected, an SMP panel is provided but the sensor and relay for the zero-sequence ground fault protection of the SMP are not present. The ground fault sensor and relay are replaced by the SEPAM module and three individual current sensors.

In order to employ differential motor protection, the chiller must be equipped with a large motor (1062 kw and above) and the motor and motor terminal board is of 6 lead construction.

The DMP option consists of three current transformers (one on each motor phase to monitor the current in and out of each of the motor windings), and a controlling module. If a fault is detected in the current flow of the motor, the module opens a contact and interrupts the control power to the starter contactors, causing the system to shut down.

The DMP module is located in the low voltage section in the lower right corner of the SMP enclosure. The module is a Square D (Schneider Electric) "Sepam Series 20" protection unit.

SEPAM module display

Figure 6. SEPAM module front panel

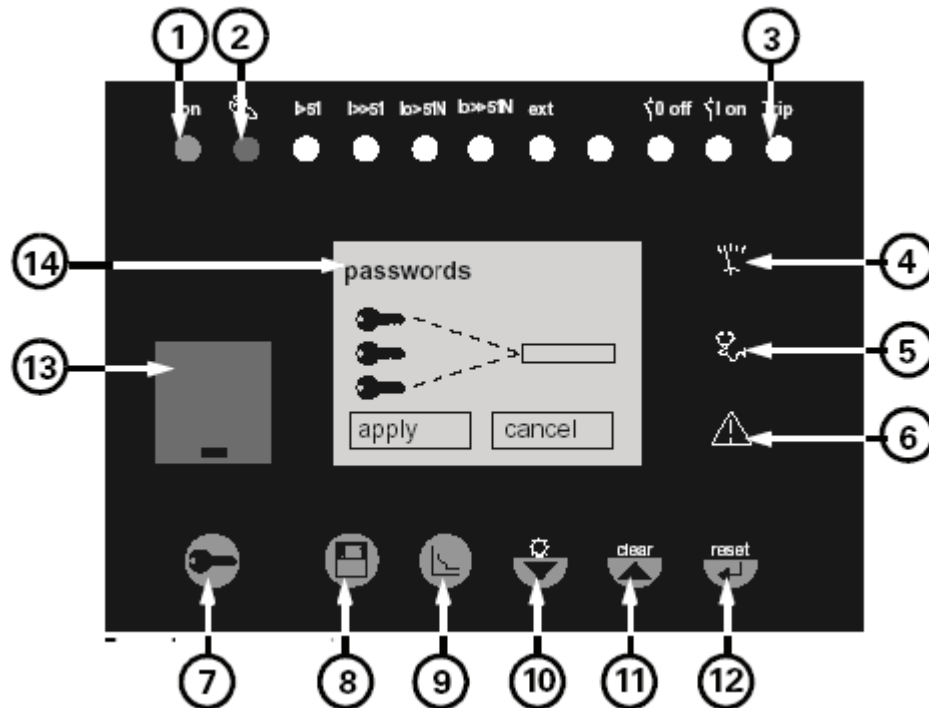

1. **Green “On” indicator.** This indicator is lit when power is applied to the Sepam and it is functional.
2. **Red “Wrench” indicator.** This indicator is lit when the Sepam is not functional due to an internal fault. This indicator also flashes for several seconds when control power is first applied to the Sepam.
3. **“Trip” indicator.** This indicator is lit when the Sepam has detected a chiller motor fault. Chiller operation is prevented.
The remaining indicators along the top edge of the Sepam are not active for the Trane application.
4. **“Metering” display key.** This key scrolls the main display through the available metering data screens.
5. **“Diagnostics” key.** This key scrolls the main display through the available diagnostic screens.
6. **“Alarm” display key.** This key displays the 16 most recent alarm events.
7. **“Reset/enter” key.** This key, when pressed after a trip event, resets the Sepam module and allows another unit operation attempt. Also use this key to confirm protection settings, parameter settings, and passwords.

8. **“Clear” key.** Pressing this key when an alarm is shown on the main display returns the main display to the previous screen. If the main display is in the Metering data screens, pressing the Clear key resets the average and peak demand currents. If the main display is in the Diagnostic screens, pressing the Clear key resets the run hour counter. If the main display is in the Alarm display screen, pressing the Clear key erases the 16 stored alarms. Also press the Clear key to scroll up through menu choices.
9. **“Lamp test” key.** Press and hold this key for five seconds to initiate a test of the display indicators (lamps). Also use the Lamp test key to scroll down through menu choices.
10. **“Protection settings” key.** This key accesses the Sepam’s protection settings. Password access is required to change settings.
11. **“Parameter settings” key.** This key accesses the Sepam’s parameter or general settings. Password access is required to change settings.
12. **“Password” key.** This key allows the user to enter passwords to access and change the protection or parameter setting menus.
13. Connection port for Square D laptop interface (not required for the Trane application).
14. Main display.

For detailed information, refer to the Square D (Schneider Electric) literature 63230-216-208B1, *Sepam Series 20 Digital Relay Installation Guide*. To access the SEPAM literature on-line go to: <http://www.squared.com/us/products/powerlog.nsf/DocumentsByCategory?OpenView&Start=1&Count=999&Expand=14.2#14.2>

Default SEPAM parameter settings for the Trane application

No password is necessary to view the settings in the Parameter menus, but they cannot be changed.

If it is necessary to change any Parameter settings, first press the Password key to enter the password screen, then enter the appropriate password. The default password is 0000.

If any settings in a menu are changed, scroll to the bottom of the menu and select and enter “apply” to make the change effective.

1. Press the Parameter key to enter the General Settings menu. The default settings are:
Language:..... English
Frequency:..... 60
A/B Selection:..... A
Remote Settings: Off
Settings Mode:..... 10 I/Is
Passwords: 0000 (default for both)
2. Press the Parameter key to enter the About Sepam menu. The default settings are:
Type: S20
VO247
UMIVO232

SMP installation

3. Press the Parameter key to enter the MES 108/114 menu. The default settings are:
MES 108/114 Off
The settings in this menu do not apply to the Trane application.
4. Press the Parameter key to enter the MODBUS menu. The default settings are:
MODBUS Off
The settings in this menu do not apply to the Trane application.
5. Press the Parameter key to enter the MSA 141 menu. The default settings are:
MSA 141 Off
The settings in this menu do not apply to the Trane application.
6. Press the Parameter key to enter the Current Sensors menu. The default settings are:
Phase
 - Sensors:..... 1 - I2 - I3
 - In 50.0A/5A: (CT primary rating)Residual
 - Sensor Sum:..... 3I
 - In0: 50.0AIntegration Period: 5mn
Ib: 50.0A
7. Press the Parameter key to enter the O1 Output menu. The default settings are:
O1 Output:..... On
Trip Coil: Shunt
Mode
8. Press the Parameter key to enter the Digital I/O menu. Use this menu to test the function of the Sepam fault contacts connected into the starter safety circuit (connected between terminals 1X1-18 and 1X1-4). To Test:
 - Main chiller power off, 120vac control power applied.
 - Chiller in local stop.
 - Place volt meter across 1X1-18 and 1X1-4
 - Ok status is normally closed (0 volts).
 - In the Digital I/O menu, select Test 02.
 - Select Test.
 - The 02 relay will open, confirm with volt reading (120 volts).
 - The 02 relay will automatically re-close after a few seconds.
 - Press the Parameter key to enter the Control Logic menu. Default settings are:
 - CB Control Off
 - SSL..... Off

Default SEPAM protection settings for the Trane application

No password is necessary to view the settings in the Protection menus, but they cannot be changed.

If it is necessary to change any Protection settings, first press the Password key to enter the password screen, then enter the appropriate password.

If any settings are changed, scroll to the bottom of the menu and select and enter “apply” to make the change effective.

Press the Protection key to enter the Protections Menu. The default settings are:

50/51 1A:..... On

- Trip
- Curve SIT
- Threshold “Is” 15A
- Delay 100ms
- Timer Hold
- Curve Definite
- Delay 0.00ms

50/51 1B..... On

- Trip
- Curve SIT
- Threshold “Is” 15A
- Delay 100ms
- Timer Hold
- Curve Definite
- Delay 0.00ms

50/51 2A..... Off

50/51 2B..... Off

50N/51N 1A Off

50N/51N 1B Off

50N/51N 2A Off

50N/51N 2B Off

46 Off

79 Off

Please refer to Trane’s Starter By Others specification S6516-0513. If an INDP-equipped chiller is shipped from the factory with no starter installed, and is to be equipped with a “starter by others” (i.e., the starter is NOT provided by Trane), then the control panel will also be equipped with the items defined in [Table 4, p. 20](#)

SMP installation

Table 4. Remote “starter by others” to control panel terminations

| Wire # or device designation | Control panel termination | Acceptable wire | Recommended starter panel termination | Note |
|---|---------------------------|-----------------|---------------------------------------|------|
| 120 V control wiring | | | | |
| 120 Vac power supply, wire 1A | 1x1-1 | #8 AWG | 5x1-1 | |
| 120 vac power supply, wire 2A | 1x1-12 | #8 AWG | 5x1-12 | |
| 120 vac power supply, wire GND | GND | #8 AWG | 5x1-Ground | |
| Oil Pump Interlock, wire 9A | 1A7 J2-4 | #14 AWG | 5x1-7 | |
| Oil Pump Interlock, wire 10A | 1A7 J2-2 | #14 AWG | 5x1-8 | |
| Interlock Relay Signal, wire 15A | 1x2-2 | #10 AWG | 5x1-4 | |
| Start signal, wire 16A | 1x2-3 | #10 AWG | 5x1-5 | |
| Run signal, wire 18A | 1x2-4 | #10 AWG | 5x1-10 | 1 |
| Transition complete signal, wire 3B | 1x1-3 | #10 AWG | 5x1-3 | 1 |
| Transition complete signal, wire 13A | 1x2-1 | #10 AWG | 5x1-14 | 1 |
| Starter Fault 5A10-K1 | 1A24 J2-1, J2-2 | #14 AWG | 5x1-11, 5x1-12 | 5 |
| Low Voltage Wiring (<30 Vac) | | | | |
| From secondary CT 5CT4, white - black | 1x2-19, 1x2-20 | #10 AWG | 5x1-19, 5x1-20 | 2 |
| From secondary CT 5CT5, white - black | 1x2-21, 1x2-22 | #10 AWG | 5x1-21, 5x1-22 | 2 |
| From secondary CT 5CT6, white - black | 1x2-23, 1x2-24 | #10 AWG | 5x1-23, 5x1-24 | 2 |
| From PT 5T17, wires 236, 237 | 1x2-25, 1x2-26 | #10 AWG | 5x1-25, 5x1-26 | 3 |
| From PT 5T18, wires 238 | 1x2-27, 1x2-28 | #10 AWG | 5x1-27, 5x1-28 | 3 |
| From PT 5T19, wires 240, 241 | 1x2-29, 1x2-30 | #10 AWG | 5x1-29, 5x1-30 | 3 |
| 120v Voltage Sensing (note 4) | | | | |
| From line/120 3ph primary PT, wire 216A | 1S1 disconnect, L1 | #8 AWG | 5T9 | 4 |
| From line/120 3ph primary PT, wire 217A | 1S1 disconnect, L2 | #8 AWG | 5T9 | 4 |
| From line/120 3ph primary PT, wire 218A | 1S1 disconnect, L3 | #8 AWG | 5T9 | 4 |

Notes:

1. For transitioning starter types only.
2. INDP chillers that are also equipped with the SMP (Supplemental Motor Protection) or the DMP (Differential Motor Protection) options do not require the field installation of primary or secondary CTs. The protection panel of these chillers will contain the required CTs factory installed and wired to the UC800.
3. Only in INDP chillers with low voltage motors (<600v).
4. Only in INDP chillers with medium voltage motors (>600v). These chillers have secondary PTs factory-installed in the UC800.
5. Solid State Starter types only

Industrial Terminal Block

For a Starter By Others application, the control panel of the INDP chiller contains a screw-type terminal block (1X2) in it's upper left corner. Customers should use this terminal block when connecting field-installed wiring. The wiring for current transformers, potential transformers, contactor control, etc. is connected to this terminal block. The customer is not required to connect field wires directly to the individual UC800 LLIDs (starter module 1A23, etc.). The terminal block accepts wire sizes from #24 to #10 AWG. Torque these terminals from 4.4 to 7 lb-in (0.5 to 0.8 Nm).

Three-Pole Disconnect

If the chiller is Starter By Others and is INDP-equipped, the control panel is also equipped with a three-pole disconnect on secondary potential transformers (1S1).

Secondary PTs

If the chiller is Starter By Others and is INDP-equipped, the secondary potential transformers (1T2, 1T3, 1T4) for the UC800 voltage sensing feature are factory-installed into the control panel enclosure. These transformers take the nominal 120 Vac signal provided from the (1S1 3-pole disconnect) primary potential transformer (customer-supplied) and reduce it to nominal 30 Vac inputs for the UC800. It will still be necessary for the customer to provide a line:120 primary potential transformer as defined in the Starter By Others specification.

Current Transformers

If the chiller is INDP equipped with the SMP option, and it is also a Starter By Others application, the SMP enclosure will contain factory-installed, single-stage current transformers (4T1, 4T2, and 4T3). These transformers provide the motor current sensing needed by the UC800, the customer will not have to provide primary or secondary CTs for this purpose.

Vacuum Circuit Breaker (CVAC)

If the Starter By Others device provided by the customer employs a vacuum circuit breaker to start and stop the chiller motor, the INDP chiller control panel enclosure will contain two relays (1K1 and 1K2) to enable control of the breaker by the unit controls. The relays are 120 Vac, 50/60 Hz, as configured 10 A, 125 Vdc resistive.



SMP installation



SMP installation



Trane
A business of American Standard Companies
www.trane.com

For more information, contact your local Trane office or e-mail us at comfort@trane.com

| | |
|-------------------------|---------------|
| Literature Order Number | CTV-SVX07A-EN |
|-------------------------|---------------|

| | |
|------|--------------|
| Date | January 2008 |
|------|--------------|

| | |
|------------|-----|
| Supersedes | New |
|------------|-----|

Trane has a policy of continuous product and product data improvement and reserves the right to change design and specifications without notice.