



Installation Instructions

Replacement Economizer CentraVac™ Chillers

Models: CVHE, CVHF, CVHG, CDHF, CDHG

SAFETY WARNING

Only qualified personnel should install and service the equipment. The installation, starting up, and servicing of heating, ventilating, and air-conditioning equipment can be hazardous and requires specific knowledge and training. Improperly installed, adjusted or altered equipment by an unqualified person could result in death or serious injury. When working on the equipment, observe all precautions in the literature and on the tags, stickers, and labels that are attached to the equipment.

January 2014

PART-SVN215A-EN





Warnings, Cautions, and Notices

Warnings, Cautions, and Notices. Note that warnings, cautions and notices appear at appropriate intervals throughout this manual. Warnings are provided to alert installing contractors to potential hazards that could result in death or personal injury. Cautions are designed to alert personnel to hazardous situations that could result in personal injury, while notices indicate a situation that could result in equipment or property-damage-only accidents.

Your personal safety and the proper operation of this machine depend upon the strict observance of these precautions.

Read this manual thoroughly before operating or servicing this unit.

ATTENTION: Warnings, Cautions, and Notices appear at appropriate sections throughout this literature. Read these carefully:

⚠ WARNING Indicates a potentially hazardous situation which, if not avoided, could result in death or serious injury.

⚠ CAUTION Indicates a potentially hazardous situation which, if not avoided, could result in minor or moderate injury. It could also be used to alert against unsafe practices.

NOTICE: Indicates a situation that could result in equipment or property-damage only accidents.

Important Environmental Concerns!

Scientific research has shown that certain man-made chemicals can affect the earth's naturally occurring stratospheric ozone layer when released to the atmosphere. In particular, several of the identified chemicals that may affect the ozone layer are refrigerants that contain Chlorine, Fluorine and Carbon (CFCs) and those containing Hydrogen, Chlorine, Fluorine and Carbon (HCFCs). Not all refrigerants containing these compounds have the same potential impact to the environment. Trane advocates the responsible handling of all refrigerants-including industry replacements for CFCs such as HCFCs and HFCs.

Responsible Refrigerant Practices!

Trane believes that responsible refrigerant practices are important to the environment, our customers, and the air conditioning industry. All technicians who handle refrigerants must be certified. The Federal Clean Air Act (Section 608) sets forth the requirements for handling, reclaiming, recovering and recycling of certain refrigerants and the equipment that is used in these service procedures. In addition, some states or municipalities may have additional requirements that

must also be adhered to for responsible management of refrigerants. Know the applicable laws and follow them.

⚠ WARNING

Proper Field Wiring and Grounding Required!

All field wiring **MUST** be performed by qualified personnel. Improperly installed and grounded field wiring poses **FIRE** and **ELECTROCUTION** hazards. To avoid these hazards, you **MUST** follow requirements for field wiring installation and grounding as described in **NEC** and your local/state electrical codes. Failure to follow code could result in death or serious injury.

⚠ WARNING

Personal Protective Equipment (PPE) Required!

Installing/servicing this unit could result in exposure to electrical, mechanical and chemical hazards.

- Before installing/servicing this unit, technicians **MUST** put on all PPE required for the work being undertaken (Examples; cut resistant gloves/sleeves, butyl gloves, safety glasses, hard hat/bump cap, fall protection, electrical PPE and arc flash clothing). **ALWAYS** refer to appropriate Material Safety Data Sheets (MSDS)/Safety Data Sheets (SDS) and OSHA guidelines for proper PPE.
- When working with or around hazardous chemicals, **ALWAYS** refer to the appropriate MSDS/SDS and OSHA/GHS (Global Harmonized System of Classification and Labelling of Chemicals) guidelines for information on allowable personal exposure levels, proper respiratory protection and handling instructions.
- If there is a risk of energized electrical contact, arc, or flash, technicians **MUST** put on all PPE in accordance with OSHA, NFPA 70E, or other country-specific requirements for arc flash protection, **PRIOR** to servicing the unit. **NEVER PERFORM ANY SWITCHING, DISCONNECTING, OR VOLTAGE TESTING WITHOUT PROPER ELECTRICAL PPE AND ARC FLASH CLOTHING. ENSURE ELECTRICAL METERS AND EQUIPMENT ARE PROPERLY RATED FOR INTENDED VOLTAGE.**

Failure to follow instructions could result in death or serious injury.

Trademarks

CenTraVac, Tracer AdaptiView, Trane, and the Trane logo are trademarks of Trane in the United States and other countries. All trademarks referenced in this document are the trademarks of their respective owners.

Introduction

The following instructions show the installation of the economizer on CDHF, CHDG, CVHE, CVHF, or CVHG CenTraVac chillers. When a replacement economizer is ordered through Trane Parts for field installation, the new economizer is shipped as follows: a new painted economizer with pipe stubs and welded caps, with a 1/4-in. angle valve supplied to allow removing the 5 psig holding charge of dry nitrogen. Lifting lugs are provided on the welded caps of the condenser and evaporator tube stubs to allow ease of lifting.

All weld rings, reducers, couplings etc. that may be needed to fit up the economizer are to be purchased locally. The original pipe flanges along with a section of the piping will need to be reused. Mounting brackets will also need to be reused.

New gaskets for all of the economizer flanges will need to be ordered through Trane Parts based on the serial number of the chiller. The oil cooler will be supplied if originally installed, and the protruding 5/8-in. copper tube stubs of the oil cooler will be protected with steel couplings secured with set screws.

Note: The illustrations in this document show the current production economizer used on 2-stage units. The difference between the 2-stage and 3-stage economizer is the number of connections on the top: the 2-stage economizer has one connection and the 3-stage has two connections.



Installation

⚠ WARNING

Hazardous Voltage w/Capacitors!

Disconnect all electric power, including remote disconnects and discharge all motor start/run capacitors before servicing. Follow proper lockout/tagout procedures to ensure the power cannot be inadvertently energized. For variable frequency drives or other energy storing components provided by Trane or others, refer to the appropriate manufacturer's literature for allowable waiting periods for discharge of capacitors. Verify with an appropriate voltmeter that all capacitors have discharged. Failure to disconnect power and discharge capacitors before servicing could result in death or serious injury.

For additional information regarding the safe discharge of capacitors, see PROD-SVB06A-EN

⚠ WARNING

Refrigerant May Be Under Positive Pressure!

System contains oil and refrigerant and may be under positive pressure. Recover refrigerant to relieve pressure before opening the system. See unit nameplate for refrigerant type. Do not use non-approved refrigerants, refrigerant substitutes, or refrigerant additives. Failure to recover refrigerant to relieve pressure or the use of non-approved refrigerants, refrigerant substitutes, or refrigerant additives could result in an explosion which could result in death or serious injury or equipment damage.

⚠ CAUTION

Refrigerant at Freezing Temperature!

Avoid contact with skin. If working with refrigerant is necessary, you **MUST** wear all Personal Protective Equipment (PPE) including eye protection, safety gloves, long sleeves, and pants. In case of contact, treat the injury similar to frostbite. Slowly warm the affected area with lukewarm water and seek immediate medical attention. Direct contact with liquid refrigerant could result in minor to moderate injury.

⚠ CAUTION

Sharp Edges!

The service procedure described in this document involves working around sharp edges. To avoid being cut, technicians **MUST** put on all necessary Personal Protective Equipment (PPE), including gloves and arm guards. Failure to follow recommendations could result in minor to moderate injury.

1. Stop the chiller and properly remove the refrigerant or nitrogen holding charge. Refer to *Installation, Operation, and Maintenance: Refrigerant Handling Guidelines* (CTV-SVX05B-EN, or the most recent revision).
2. When the replacement economizer is received, check to make sure the nitrogen holding charge (5 psig nominal) is present. If not, then a leak has developed and will need to be repaired, unless it is at one of the weld joints for the sealing caps that will be removed for installation.
Important: If the economizer must be stored for any length of time before it is installed, then make sure there are no leaks and that the 5 psig nitrogen holding charge is present.
3. Take measurements of the old economizer for height and distance from the shell to allow the new one to be positioned in the same location.

Figure 1.

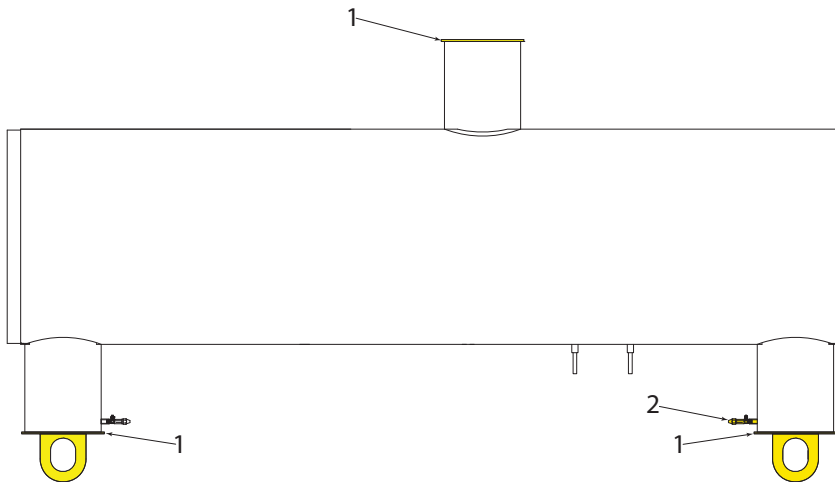

- To install the new economizer, it will be necessary to cut the sealing caps (see Figure 1, Item 1) off the pipe stubs after relieving the holding charge of dry nitrogen through the 1/4-in. valve (see Figure 1, Item 2).

Note: When cutting lines or caps on the new economizer, orient the economizer so that cutting debris do not fall into the economizer. Best practice is to use a grinding wheel to make the cuts and grind away the welds.

Figure 2.

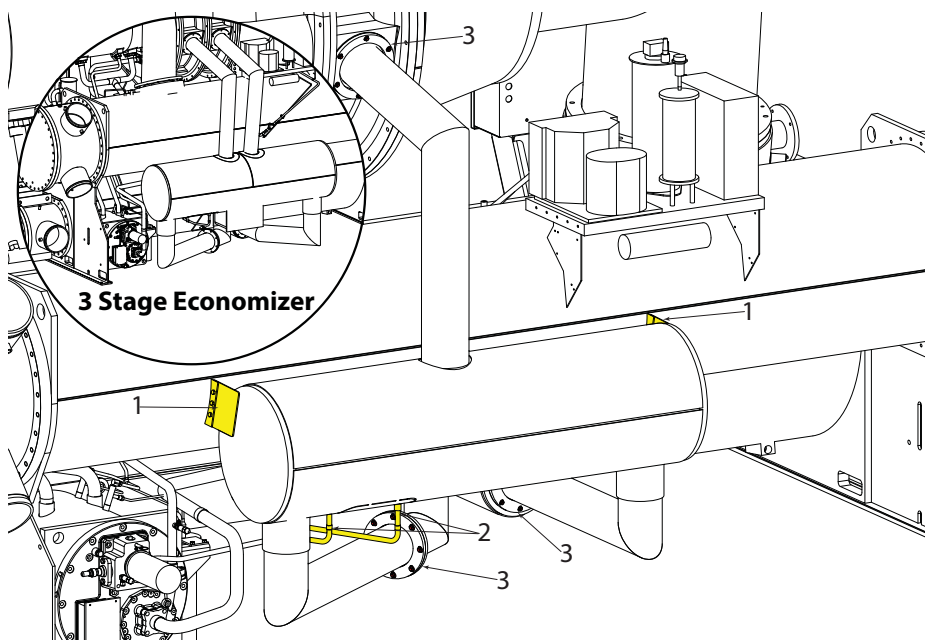

- Cut the mounting brackets (see Figure 2, Item 1) off the old economizer for reuse on the new one. Unbolt the economizer brackets from the companion brackets on the condenser.
- Remove the paint from the oil cooler copper lines at the location where they will be cut. This can be done using sand cloth or equivalent.

NOTICE:
Bearing Damage!

When cutting the lines, take care to ensure that no foreign material is introduced into the lines and never use a hacksaw to cut the lines. De-bur the cut tubing as necessary to prevent any small copper shavings from getting into the bearings. The oil cooler lines are downstream from the oil filter so any contamination or debris could affect the bearing system and cause equipment damage.

7. Using a tubing cutter, cut the 5/8-in. copper lines (see [Figure 2, p. 5](#), Item 2) going to the old oil cooler.
8. Cap or tape the cut tubes to prevent any contamination from getting into the oil lines during the economizer removal/installation.

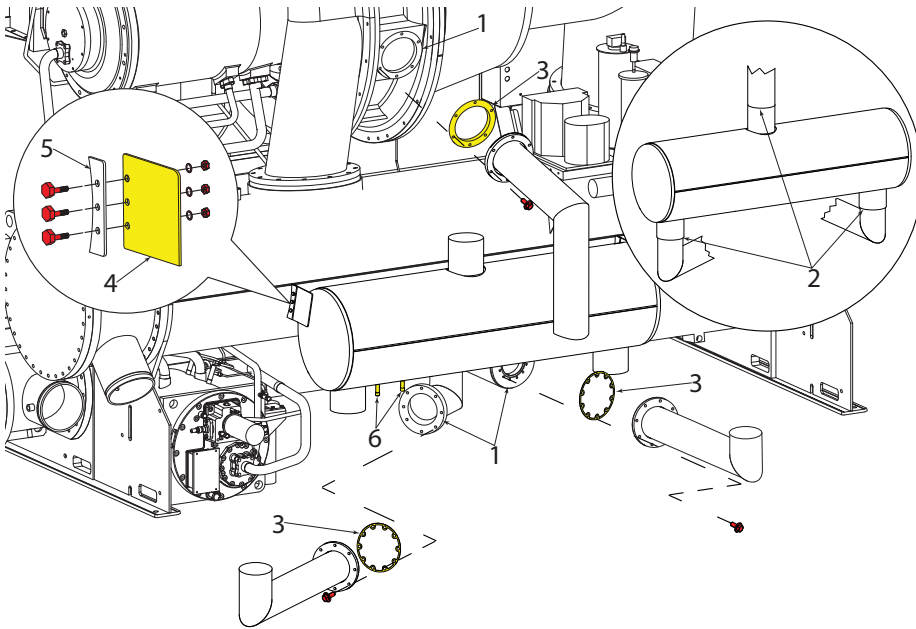
Figure 3.

Tip: Place a wet towel on the line before the flange to allow the old gaskets to remain in place during welding, which will retain correct spacing and result in a better fit up of the lines.

11. With the old gaskets in place, tighten economizer pipes to the flange connections on the unit (see [Figure 3](#), Item 1).

Note: The economizer and pipe stubs are made of A36 low carbon steel. The preferred welding rods for stick welding is E7018 or if MIG welding, use filler wire ER70S-6 (AWS). If the economizer is not ASME-rated and if E7018 is not readily available, then it is permissible to use E7016 or E6011 for stick welding.

12. The economizer should be oriented and supported so that its position is the same as the measurements taken in [Step 3](#).

9. Remove the old economizer at the flange connections (see [Figure 2, p. 5](#), Item 3) and position the new one in the same location as the old one. Make sure to support it in the position to allow the pipes to be welded.
10. Measure the length of the pipe required to allow fit-up with the new economizer pipe stubs for the vent lines, condenser line, and evaporator line. Cut the existing pipe to fit based on the measurements taken.

Note: The use of weld rings (internal or external are acceptable) is recommended for pipe connections; obtain the weld rings locally. The pipes can be butt welded if necessary, but doing so increases the risk of weld debris entering into the system.

Important:

- For economizers without oil coolers (i.e., for the small CVHE machines), it is possible to reverse the entering and leaving connections. Look into the pipe stubs and note the following:
 - The entering connection (from condenser to economizer) will have a perforated plate located above the entry hole.
 - The leaving connection (from the economizer to the evaporator) will have a vertical plate (baffle) welded in place to straighten the flow.
 - It's critical to make sure that the orientation is correct prior to welding. Performance issues will result if the economizer is piped in backwards.
13. Weld the economizer pipes in place at the economizer pipe stub connections (see [Figure 3](#), Item 2).

14. Once the pipes have cooled, unbolt the flange connections and install new gaskets (see [Figure 3](#), Item 3) at all of the economizer flange connections.
 15. Install the original mounting brackets (see [Figure 3](#), p. 6, Item 4) by welding them to the economizer to mate with the companion brackets on the condenser (see [Figure 3](#), p. 6, Item 5).
 16. Torque all flange bolts for the economizer flange connections to the proper specification using a crossing pattern. Consult with your Trane service group for specific torques for your economizer design.
 17. Remove the protective steel couplings from the oil cooler stubs (see [Figure 3](#), p. 6, Item 6) and caps or tape from the cut oil cooler lines. Field-pipe the oil cooler lines that were cut (5/8-in. type "L" copper).
- Note: When brazing, use alloy BCuP-6 (2 percent silver content) or equivalent (higher silver content is acceptable). These alloys do not require flux when brazing copper to copper joints.*
18. Purge the oil cooler lines with dry nitrogen while brazing to prevent copper oxides from contaminating the oil system. A 5/8-in. swaging tool or 5/8-in. copper coupling can be used to allow tube connection.
 19. After installing the new economizer, a thorough leak test is required to ensure hermetic integrity. Repair any leaks found before proceeding with unit evacuation.



Trane optimizes the performance of homes and buildings around the world. A business of Ingersoll Rand, the leader in creating and sustaining safe, comfortable and energy efficient environments, Trane offers a broad portfolio of advanced controls and HVAC systems, comprehensive building services, and parts. For more information, visit www.Trane.com.

Trane has a policy of continuous product and product data improvement and reserves the right to change design and specifications without notice.