



# General Service Bulletin

**CVHE-SB-44**

Library	Service Literature
Product Section	Refrigeration
Product	Centrifugal Liquid Chillers
Model	CVHE/F/G
Literature Type	General Service Bulletin
Sequence	44
Date	October 29, 1997
File No.	NEW

## Subject: Solid State Starter Logic Module (2U2) Failures

### Introduction:

The purpose of this bulletin is to provide troubleshooting and replacement information on the solid state starters used on the CVHE/CVHF/CVHG units.

### **IMPORTANT!**

**TO PREVENT INJURY OR DEATH DUE TO ELECTRICAL SHOCK, PLEASE FOLLOW THE WARNINGS PROVIDED THROUGHOUT THIS MANUAL REGARDING HAZARDOUS VOLTAGE WHEN SERVICING.**

### Discussion:

The Trane solid state starter is designed to start the chiller motor smoothly at a reduced torque and current. A complete starter consists of a 2U1 starter module, a 2U2 solid state controller, MOV (Metal Oxide Varistor) transient suppressers, and a 3-pole, 6 SCR, full wave power section all mounted in a common panel. All of the regulating, gating and logic functions are contained in the 2U2 logic module.

The original 2U2 logic module has an internal bridge rectifier that is undersized. This undersized component can fail and cause mis-firing of the gates leading to poor ramp-up of the motor. Follow the procedures below to troubleshoot the starter. The procedure will work on any version of logic module.

### Corrective Action:

Several procedures are listed below to assist in determining which component in the starter has failed.

Since the Trane Company has a policy of continuous product improvement, it reserves the right to change specifications and design without notice. The installation and servicing of the equipment referred to in this booklet should be done by qualified, experienced technicians.

---

## Logic Module (2U2) Control Settings and Adjustments

The 2U2 Logic module has three adjustable potentiometers.

### **▲ WARNING**

#### **HAZARDOUS VOLTAGE**

**DISCONNECT ALL ELECTRIC POWER INCLUDING REMOTE DISCONNECTS BEFORE SERVICING.**

**Failure to disconnect power before servicing can cause severe personal injury or death.**

Refer to Figure 1.

1. Starting Current - Factory Set @ 100% (full counter clockwise).
2. Current Limit - Factory Set @ 300%
3. Ramp Time - Factory Set @ 5 to 6 seconds.

The 2U2 Logic module also has three unused potentiometers.

The solid state starter is designed to provide adequate ramp-up current as necessary within five seconds to accelerate the motor. After the compressor is up to speed, the 2U2 logic module will close an internal set of contacts called "end of limit". When the "end of limit" contacts are closed, the compressor will be sent across the line by closing the by-pass contacts.

### Initial Check-Out Procedures

- Confirm all control voltage is separate from the power wiring.
- Confirm all wiring is landed correctly.
- Tighten all connections.
- Inspect all components for damage by inspecting the starter for arcing, overheating, and other damage.

### Fuse Check-Out

#### **WARNING**

**TO PREVENT INJURY OR DEATH DUE TO ELECTRICAL SHOCK OR CONTACT WITH MOVING**

#### **▲ PARTS,**

**use care when measurements, adjustments, or other service-related operations are performed with power on.**

Four fuses can be replaced if necessary. The fuses that need to be checked are:

- 2F1:** Each end to chassis ground should be  $\pm 10\%$  of incoming voltage.
- 2F2:** Each end to chassis ground should be  $\pm 10\%$  of incoming voltage.
- 2F3:** Each end to chassis ground should be  $\pm 10\%$  of incoming voltage.
- 2F4:** Each end to chassis ground should be 115 VAC  $\pm 10\%$ .

Figure 1  
Adjustable Potentiometers on 2U2 Module

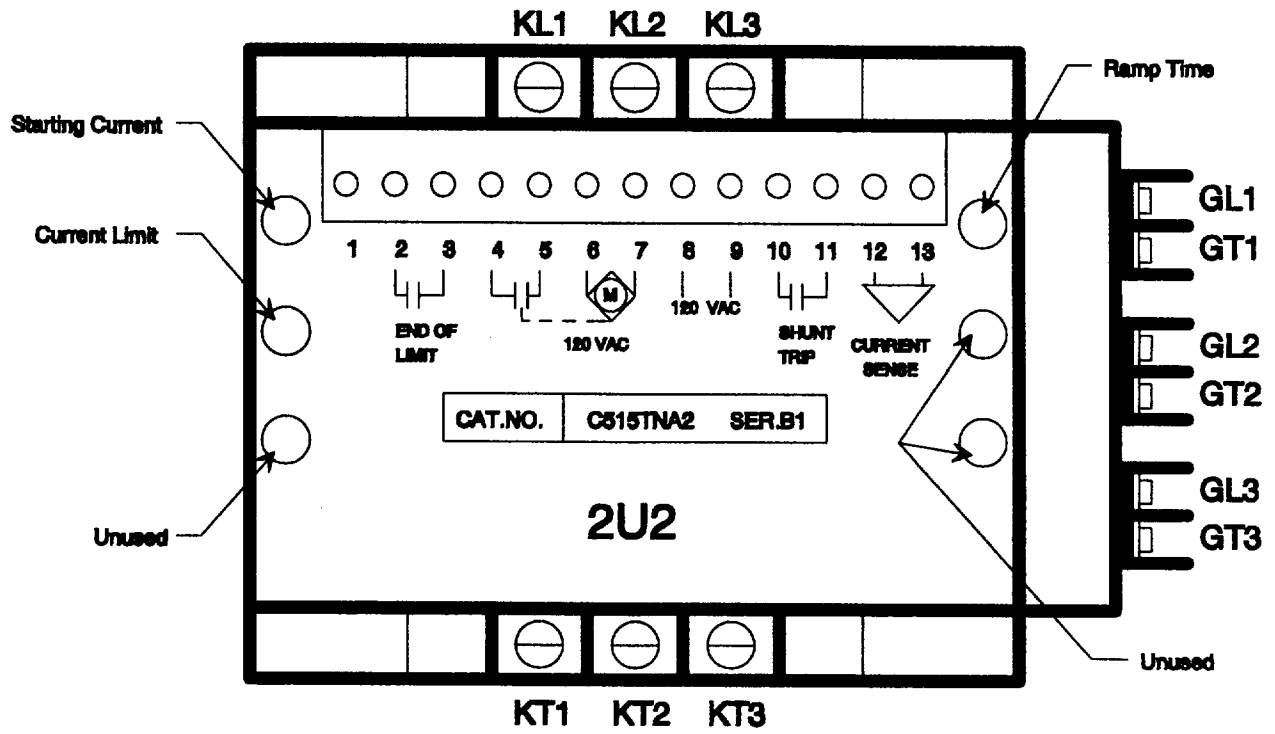

## Current Feedback Resistor (CFR) Check-Out

### **⚠ WARNING**

#### **HAZARDOUS VOLTAGE**

**DISCONNECT ALL ELECTRIC POWER INCLUDING REMOTE DISCONNECTS BEFORE SERVICING.**

**Failure to disconnect power before servicing can cause severe personal injury or death.**

Refer to the four selection tables in the chiller drawing package that shipped with the unit (schematic 260352) to confirm that the correct current feedback resistor (CFR) is installed. If the correct resistor is installed, use the tables to determine the proper resistance setting for the CFR. Use the following steps to confirm that the CFR is set for the proper resistance value.

1. Disconnect the resistor from terminals 2TB5-32 and 33.
2. Place an ohmmeter across the resistor and record the value.
3. Refer to the applicable table in schematic 260352 to determine the correct resistance value.
4. If steps 2 and 3 do not correspond, use a small set screw on the resistor to adjust the resistance value.
5. With the correct resistance value set, re-install the resistor.

For example (using schematic 260352):

Starter model number (off starter nameplate):

CVSF238\*\*\*\*\*

FLA for tables (use unit RLA found on nameplate) = 238

1. Go to tables on schematic to determine proper resistor.
2. Second table (labeled VC36ELJ) #2 shows proper resistor for the 238 RLA is C515P48.
3. If proper resistor is used, use same table to read resistance value of resistor. This CFR would be set at 850 ohms.

---

## Power Pole Check-Out

### ▲ WARNING

#### HAZARDOUS VOLTAGE

**DISCONNECT ALL ELECTRIC POWER INCLUDING REMOTE DISCONNECTS BEFORE SERVICING.**

**Failure to disconnect power before servicing can cause severe personal injury or death.**

The entire power pole must be replaced if one or more of the internal components fails the check-out procedures.

See Figure 3 for a typical Power Pole schematic for the following measurements.

1. Measure the resistance values across the terminals listed in Table 1.

**Note: It is not abnormal for two of the measurements in Table 1 to be closer together in values than the third measurement.**

2. If any of the values fall outside of the range replace the power pole.
3. If the resistances are acceptable, measure the resistance values listed in Table 2 and record.

**Table 1**  
**Power Pole Resistance with Wire Leads Connected**

Terminal Points on Power Poles	Resistance Value (Ohms)
KL1 to KT1	>10 K ohms
KL2 to KT2	>10 K ohms
KL3 to KT3	>10 K ohms

**Table 2**  
**Power Pole Resistance with Wire Leads Connected**

Terminal Points on Power Poles		Resistance Value (Ohms)
KT1 to GT1	KL1 to GL1	5-100 ohms
KT2 to GT2	KL2 to GL2	5-100 ohms
KT3 to GT3	KL3 to GL3	5-100 ohms

Figure 3  
Typical Power Pole Schematic

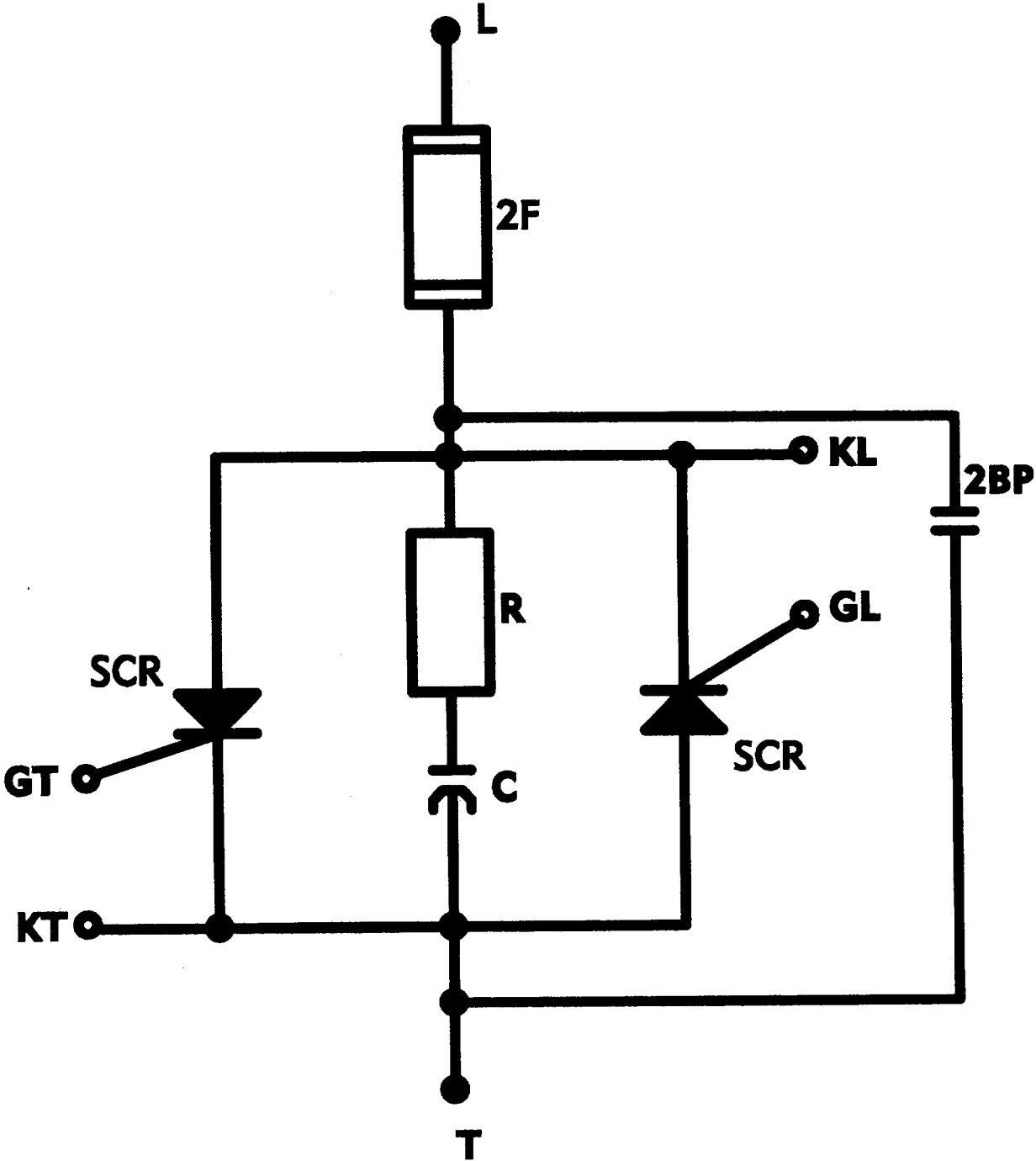

- 
4. If any of the values fall out side of the range, replace the power pole.
  5. If the resistances fall within the range, ensure that the starter is connected to the motor and proceed with Step 6.

**▲ WARNING**

**TO PREVENT INJURY OR DEATH DUE TO ELECTRICAL SHOCK OR CONTACT WITH MOVING PARTS, use care when measurements, adjustments, or other service-related operations are performed with power on.**

6. Apply power to the unit but do NOT let the compressor start. Make sure the CLD shows an operating mode of "STOP".
7. Measure and record the following voltages:

- KL1 to KT1
- KL2 to KT2
- KL3 to KT3

The measured voltage must be 0.58 times the incoming line voltage.

For example: Units with 480 VAC line to line voltage will have 278 VAC  $\pm$  5% measured between the points listed in Step 7.

8. If the voltage readings in Step 7 are out of range, replace the power pole and retest.
9. If the power poles pass the above check-out proceed with the next section.

---

## Power Pole Fan Check-Out

### **⚠ WARNING**

#### **HAZARDOUS VOLTAGE**

**DISCONNECT ALL ELECTRIC POWER INCLUDING REMOTE DISCONNECTS BEFORE SERVICING.**

**Failure to disconnect power before servicing can cause severe personal injury or death.**

Fans are used on the power poles to keep the components from overheating. Confirm that the fans are operating and that the rotation of the fans is correct.

1. The 2TR1 time delay relay will close at start-up and should pull air up from the bottom of the cabinet through the power poles.
2. The 2TR1 time delay relay will allow the fans to operate 15 minutes after shutdown.

---

## Control Power Check-Out

### **⚠ WARNING**

#### **HAZARDOUS VOLTAGE**

**DISCONNECT ALL ELECTRIC POWER INCLUDING REMOTE DISCONNECTS BEFORE SERVICING.**

**Failure to disconnect power before servicing can cause severe personal injury or death.**

The logic module (2U2) uses 120 VAC supplied by the 2T4 transformer. Check the control power by performing the following steps:

1. Measure the voltage across 2TB1-1 and 2TB1-3. The voltage must be 120 VAC  $\pm$  10%.
2. If the voltage falls out of range, check the 2F4 fuse and the 2T5 transformer.
3. If the voltage falls within range, measure the voltage between 2TB1-5 and 2TB1-3.  
The voltage must be 120 VAC  $\pm$  10%.
4. If the voltage falls out of range, check the connection and operation of the high pressure cutout switch.
5. If the voltage falls within range, check the 24 VAC control power by measuring the voltage between J2-1 and J2-2 on the 2U1.
6. If the voltage is out of range, check the 2T4 transformer.
7. If the voltages are within range, go to the next section.

---

## Logic Module Shunt Trip Check-Out

1. The Power Pole Check-Out procedure on page 4 must be conducted prior to the following tests.

### **▲ WARNING**

**TO PREVENT INJURY OR DEATH DUE TO ELECTRICAL SHOCK OR CONTACT WITH MOVING PARTS, use care when measurements, adjustments, or other service-related operations are performed with power on.**

Apply power to the starter but do NOT allow the compressor to start. If the breaker opens immediately, the internal shunt trip of the logic module (2U2) has been activated. To check the shunt trip follow the procedures below:

2. With the Starter Line Circuit Breaker open, remove the 2U1-J16 plug and isolate it. This will disable the shunt trip coil.
3. Reset and close the breaker.
4. Test the output of the logic module (2U2) between pins 10 and 11. This internal shunt trip is a dry contact closure that closes on application of power and opens on a fault.
5. If the shunt trip does not initially close, reconfirm that the power poles are operating properly. If the power poles pass the check-out procedures, replace the logic module (2U2).
6. If the shunt trip is closed, but the UCP2 is displaying a "Solid State Starter - Fault Relay Open", check the 2U1 starter module and the interconnecting wiring.

---

## Logic Module (2U2) Check-Out

### **▲ WARNING**

#### **HAZARDOUS VOLTAGE**

**DISCONNECT ALL ELECTRIC POWER INCLUDING REMOTE DISCONNECTS BEFORE SERVICING.**

**Failure to disconnect power before servicing can cause severe personal injury or death.**

Disconnect all power from the unit and perform the following steps.

1. Disconnect the leads from GL1, GL2, GL3, GT1, GT2, GT3, KL1, KL2, KL3, KT1, KT2, and KT3 at the 2U2 Logic module.
2. Measure the resistance between KL1 to GL1, KL2 to GL2, and KL3 to GL3 at the 2U2 Logic module. The resistance must be 1000 ohms  $\pm$  10 ohms.
3. Measure the resistance between KT1 to GT1, KT2 to GT2, and KT3 to GT3 at the 2U2 Logic module. The resistance must be 1000 ohms  $\pm$  10%.
4. If any of the resistances are out of range, replace the 2U2 logic module.

### **▲ WARNING**

**A PORTION OF THE FOLLOWING PROCEDURE IS DONE WITH POWER APPLIED TO UNIT.**

**TO PREVENT INJURY OR DEATH DUE TO ELECTRICAL SHOCK OR CONTACT WITH MOVING PARTS ,**

**Use Care When Measurements, Adjustments, Or Other Service-related operations Are Performed With Power On.**

5. If the resistances are correct, reconnect the leads that were removed in Step 1 and proceed with the Starting Sequence Check-out.

---

## Starting Sequence Check-Out

### **⚠ WARNING**

#### **HAZARDOUS VOLTAGE**

**DISCONNECT ALL ELECTRIC POWER INCLUDING REMOTE DISCONNECTS BEFORE SERVICING.**

**Failure to disconnect power before servicing can cause severe personal injury or death.**

If the compressor is not rotating after a start signal, follow the procedures below to confirm that the 2U2 and 2U1 modules are functioning properly.

1. Check phase rotation, it must be A-B-C. Improper wiring sequence to L1, L2 and L3 will cause the shunt trip to fault. Improper wiring to the 2U2 can also cause the shunt trip to fault.
2. Meg the compressor motor and confirm that the problem is not in the motor.

### **⚠ WARNING**

**A PORTION OF THE FOLLOWING PROCEDURE IS DONE WITH POWER APPLIED TO UNIT. TO PREVENT INJURY OR DEATH DUE TO ELECTRICAL SHOCK OR CONTACT WITH MOVING PARTS , Use Care When Measurements, Adjustments, Or Other Service-related operations Are Performed With Power On**

3. Close the disconnect and initiate the chiller through a starting sequence.
4. Measure the voltage across the 2T5 transformer and the 2F4 fuse. Place the voltmeter across 2TB1-1 and 2TB1-3, the power supply is 120 VAC  $\pm$  10%.
5. If no voltage is measured, check the fuse and the 2T5 transformer. If power is present, measure the voltage across 2TB1-3 and 2U2 pin 8. The voltage is 120 VAC  $\pm$  10%.
6. If no voltage is present, check the operation and connections of the HPC switch and the interconnecting wiring.
7. Also check the voltage across 2TB1-3 and 2U2 pin 2 for 120 VAC  $\pm$  10%. If it is not present, check wiring and connections between the transformer and the module.
8. Measure the voltage from 2U2 pin 7 to ground for 120 VAC  $\pm$  10%. If voltage is present, the heatsink motor temperature sensors may have opened.
9. Try to restart and measure the voltage from 2U2 pin 6 to 2TB1-3 for 120 VAC  $\pm$  10% at initiation of compressor start. If no voltage is present, check the 2U1 "Start" and "Stop" relays.
10. To check the 2U1 stop relay, measure the voltage between J6-3 to ground, 120 VAC  $\pm$  10% should be present any time control voltage is applied.
11. To check the 2U1 start relay, disconnect the 2P8 plug from J8-1. Measure the voltage from J8-1 to ground, 120 VAC  $\pm$  10% should be present after the start command is given.
12. If the start or stop relays are not functioning properly, replace the 2U1 starter module.
13. If the compressor starts but does not ramp properly, proceed with the ramp-up check-out of the starter.

## Starter Ramp-up Check-Out Procedure

If the compressor starts but does not have a smooth ramp-up, use the procedure below to check settings and component operation. Before using this procedure, change the following settings in UCP2 to ensure that the compressor motor does not go across the line during the test.

Located in **Service Settings, Machine Configuration Group (+ - + - + -)**

- Maximum Acceleration Timer #1 = 4
- Maximum Acceleration Timer #2 = 251
- Acceleration Time Out Action = Shutdown

1. Adjust Current Limit potentiometer on 2U2 to 100%.
2. Adjust Starting Current potentiometers to 100%.
3. Scroll to % RLA under the Compressor Report menu or place a clamp-on ammeter on each incoming leg. Monitor and record readings during start.
4. Initiate a unit start.
5. % RLA should reach 100% or ammeter should reach unit RLA listed on unit nameplate within 2 seconds, and hold the reading for 2 seconds, and the unit should then shut down on failure to accelerate.
6. If the reading is something other than the RLA listed on the nameplate ( $\pm 10\%$ ), the starter is controlling to an incorrect value. Check the operation of the 2T10 transformer and the setting of the CFR.
7. If the transformer and CFR are operating properly replace the 2U2 logic module.

**Note: Other problems can cause the compressor to have a poor ramp. For example, a compressor starting located will pull higher amps than normal and could cause the unit to go across the line.**

### **Units Affected:**

Any unit manufactured with a shipping date of July 13, 1995 through June 30, 1997 with a solid state starter must have the 2U2 logic module replaced if this module has not been replaced after July 15, 1997.

### **Parts Ordering:**

One 2U2 logic module (MOD-00444) is required for each unit with a solid state starter. Contact your local Trane Parts Center to obtain parts.