



**TRANE®**

# General Service Bulletin

---

## CVHE, CVHF, CVHG Installation Procedure for the Thrust Bearing Assembly

ORDER NO: CVHE-SB-33B

DATE: January 2003

Literature History:

CVHE-SB-33B - for CVHF 1470 and 1720

### Information:

A production design change has been made to the CVHE, CVHF, CVHG product line which affects the installation procedure for the thrust bearing assembly. This bulletin will outline these changes and explain how to identify which parts are required for field service replacement of the duplex ball bearing assembly. The proper procedure and tools required for thrust bearing replacement are outlined in this bulletin. It is also helpful to review the information in CVHE-SB-56A.

**Important:** This procedure must be followed in lieu of the procedure described in CTV-SG-2.

**NOTICE:** Warnings and Cautions appear at appropriate sections throughout this literature. Read these carefully.

**⚠ WARNING** Indicates a potentially hazardous situation which, if not avoided, could result in death or serious injury.

**⚠ CAUTION** Indicates a potentially hazardous situation which, if not avoided, may result in minor or moderate injury. It may also be used to alert against unsafe practices.

**CAUTION** Indicates a situation that may result in equipment or property-damage only accidents.

## Units Affected

All CVHE ("C" design sequence and later), CVHF and CVHG CenTraVacs are affected by this bulletin. Beginning with design sequence "2B" for the CVHE, "A" for the CVHF, and "M" for the CVHG machines, the following changes were made in production:

1. The motor shaft diameter at the thrust bearing journal was increased to provide interference fit of 0.0002" to 0.0011".
2. The number of shaft threads at the motor end of the shaft were increased.
3. The diameter of the motor shaft shoulder adjacent to the inner race of the thrust bearing assembly was increased.
4. The thrust bearing end of the motor shaft is stamped "K4" to indicate the above changes are present.

A thrust bearing design change was made in late 1999 which utilizes a center oil feed design. This information can be found in Service Bulletin CVHE-SB-56A.

**Note:** The CVHF 1470 and 1720 machines do not have threads on the thrust bearing end of the shaft but utilize a bolt and washer for bearing retention.

## Discussion:

It should be noted that the motor thrust bearing (at the OPPOSITE DRIVE END of the motor, i.e., electrical terminal end of the motor) can be replaced without disassembling the compressor.

DRIVE END refers to the shaft extension or compressor end of the motor.  
OPPOSITE DRIVE END refers to electrical terminal end of the motor.

Figures 1 and 2 show cutaway and exploded views of the motor. Refer to these and other illustrations shown during disassembly and reassembly.

## **⚠ WARNING**

### **Rotating Components!**

**Disconnect all electric power, including remote disconnects before servicing. Follow proper lockout and tagout procedures to ensure the power can not be inadvertently energized. Failure to disconnect power before servicing could result in death or serious injury.**

**Figure 1. Cutaway view of CVHE Compressor  
Motor "C" and later design sequence (axial oil feed thrust bearing shown)**

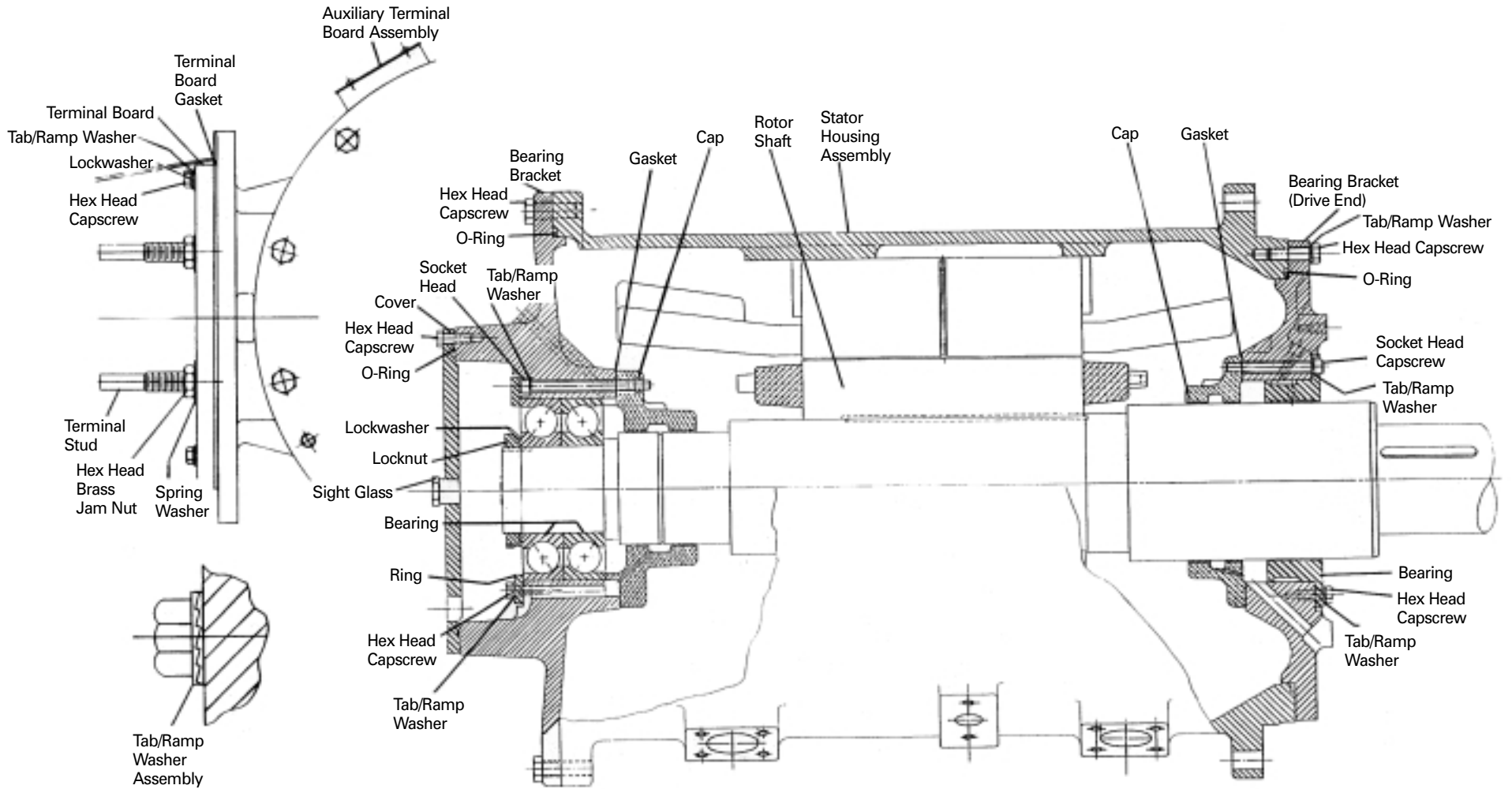
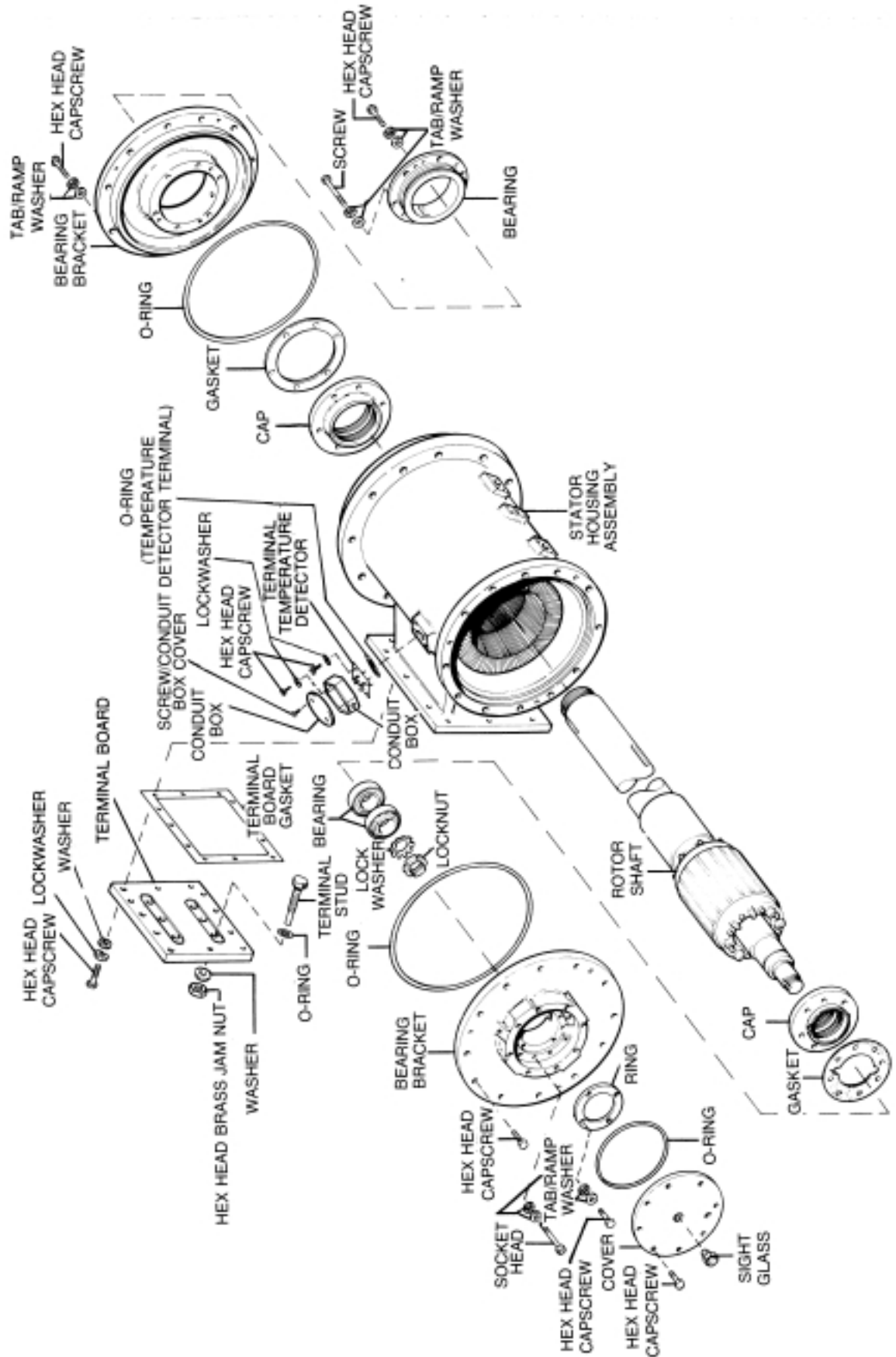


Figure 2. Exploded view of Model CVHE Compressor Motor

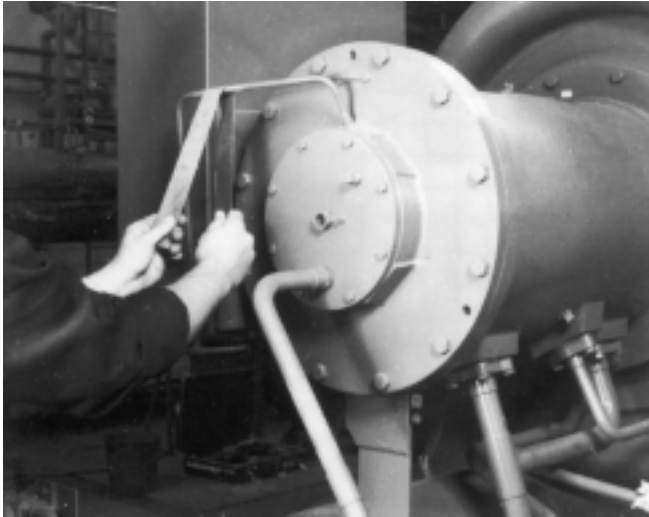


## **Motor Thrust Bearing Replacement:**

### **Disassembly**

1. Go to the OPPOSITE DRIVE END of the motor. Remove the oil supply and drain lines at this end of the motor. Paint should be removed from the lines prior to cutting the lines (use a tubing cutter) if flanges are not present to allow removal. Use sandpaper to remove the paint. See Figure 3. The cut copper tubing will be reconnected by soft soldering. All openings must be sealed while work is in progress to prevent debris from contaminating the lubrication system.
2. Remove the OPPOSITE DRIVE END bearing inspection plate. Remove the old O-ring and clean the sealing surfaces of the plate. See Figure 4.
3. To insure proper component alignment when the motor and/or compressor is reassembled, drill two 1/4-inch holes in the motor end bell which will allow for installation of two roll pins during reassembly. These holes must be drilled before loosening the motor end bell retaining bolts. Figure 4 illustrates where these holes are to be drilled. Install roll pins before proceeding with Step 4.
4. Loosen the bearing bracket (motor end bell) retaining bolts. Remove two of the bolts and replace them with guide pins which are used to support the bracket and motor shaft weight. See Figure 5.
5. Remove the four 9/16-inch capscrews and bearing retaining ring. Refer to Figure 6.
6. Remove the eight 3/8-inch-16 Allen-head screws which secure the bearing seal. See Figure 7.
7. Remove the bolts retaining the bearing bracket. There are two short bolts used in the electrical terminal box area as shown in Figure 8. These should be identified properly so that they are reinstalled correctly.

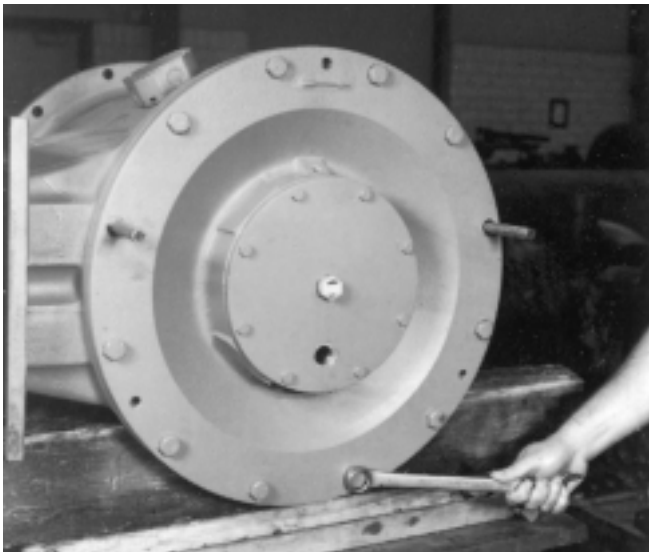
**Figure 3. Removing paint from oil supply line**



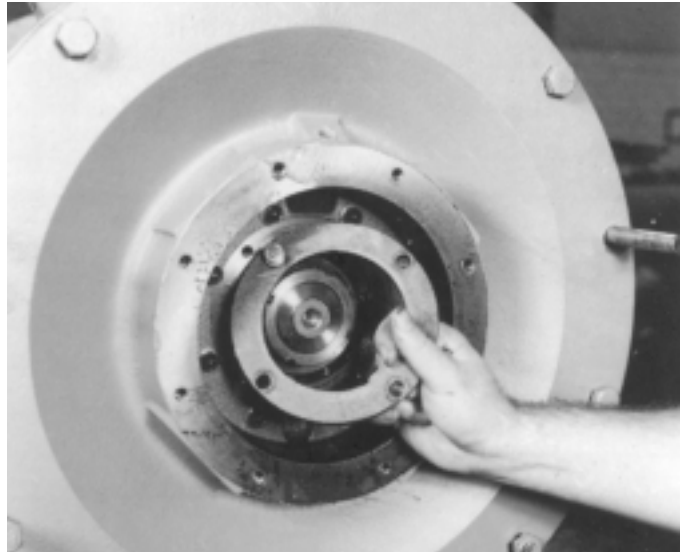
**Figure 4. Removing bearing inspection plate**



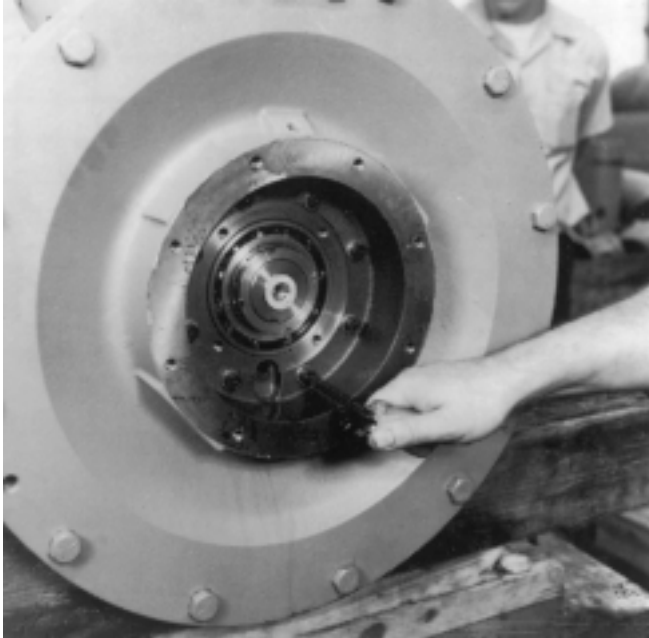
**Figure 5. Removing bearing bracket retaining bolts**



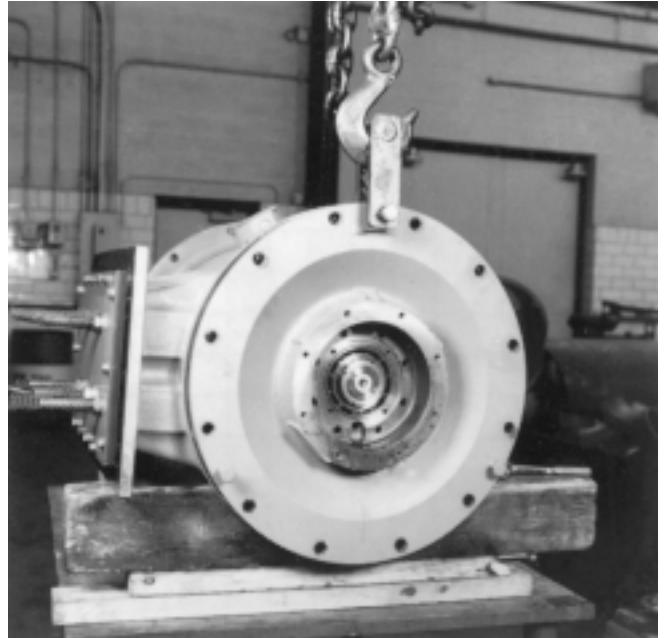
**Figure 6. Removing bearing retaining ring**



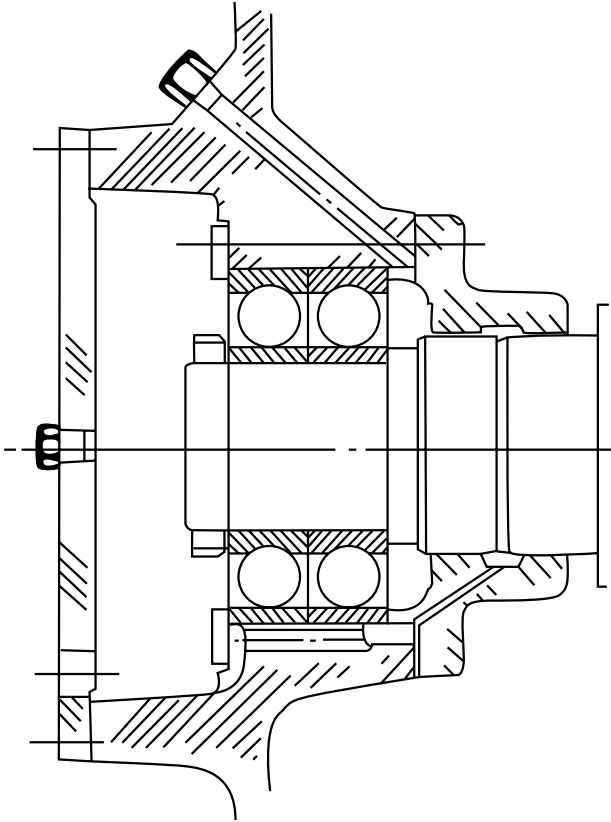
**Figure 7. Removing bearing retaining screws**



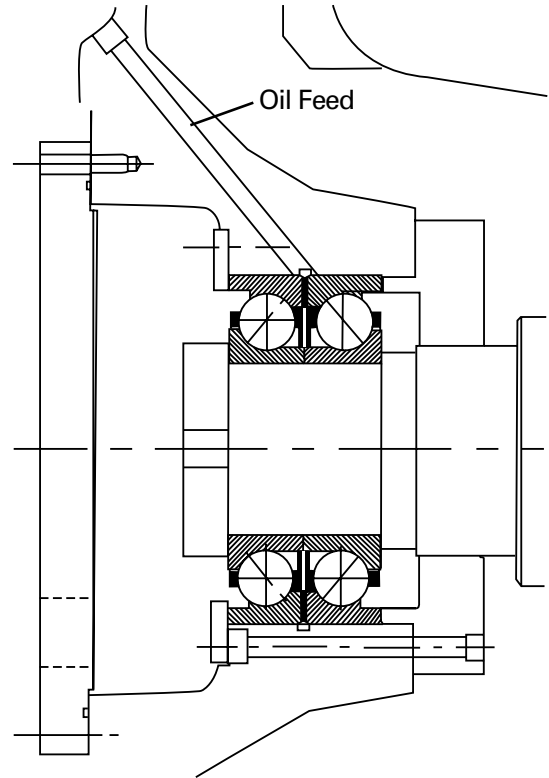
**Figure 8. Removing bearing bracket (opposite drive end)**



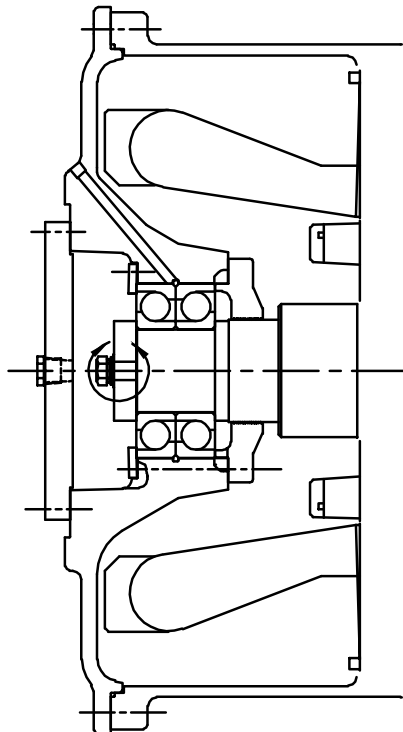
**Figure 9a. Axial feed**



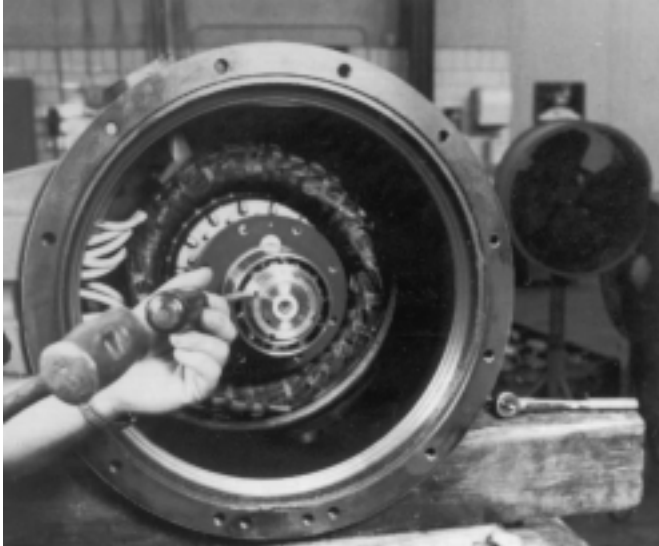
**Figure 9b. Center feed**



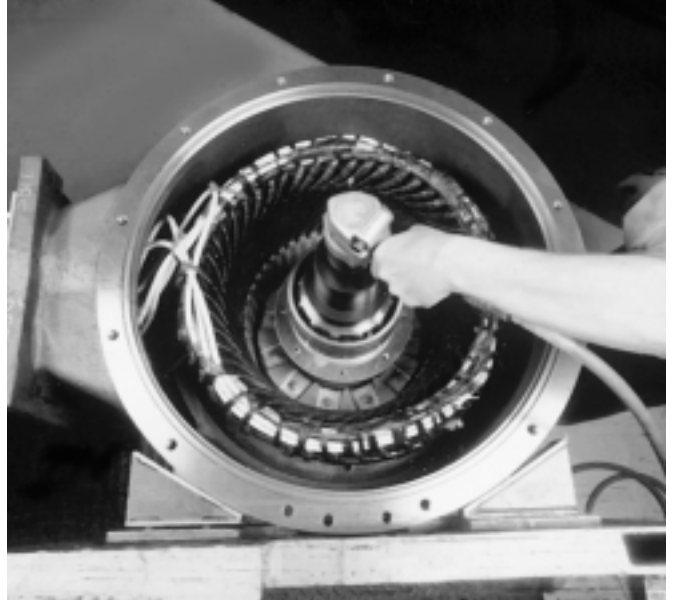
**Figure 9c. Extended capacity**



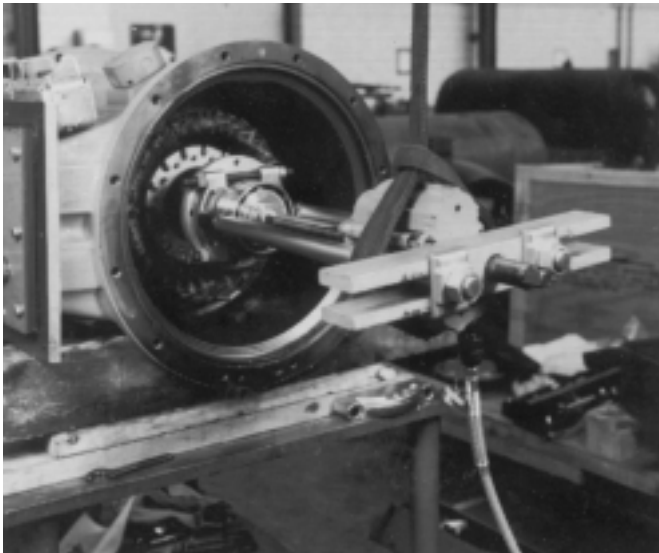
**Figure 10. Bending tab on thrust bearing lockwasher (non-extended capacity compressors)**



**Figure 11. Using socket tool to remove locknut (non-extended capacity compressors)**



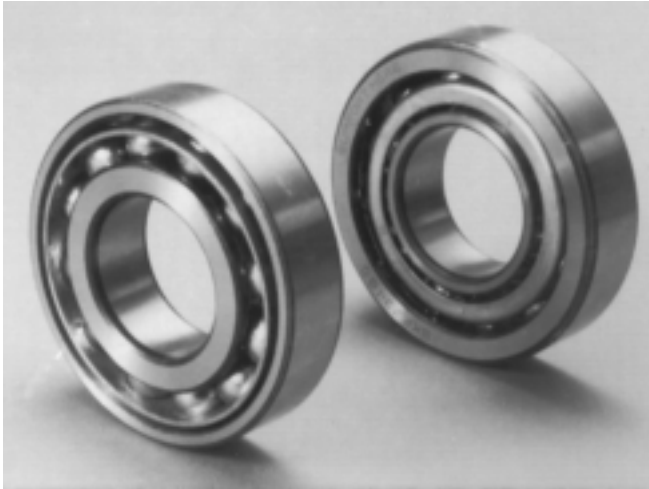
**Figure 12. Using bearing puller to remove thrust bearing**



**Figure 13. Inner bearing cap seal gasket - this gasket is not used on the center feed bearing design compressors.**

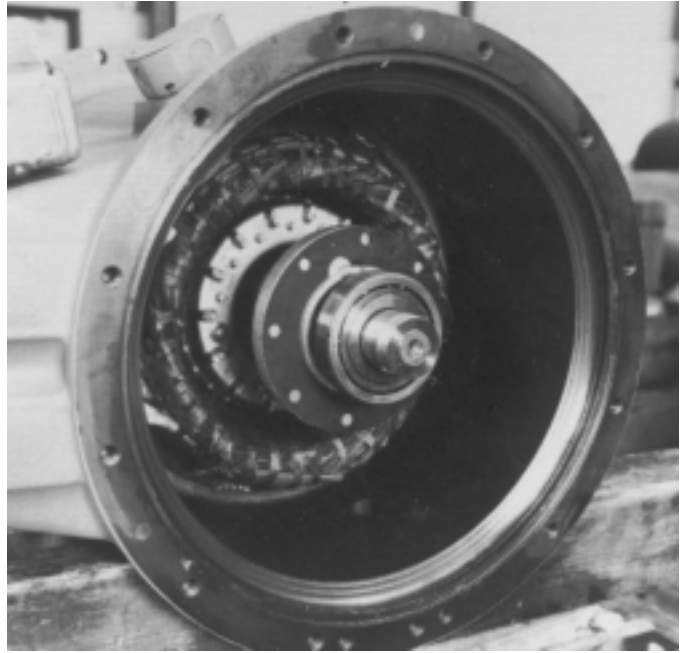


**Figure 14. Thrust bearings**

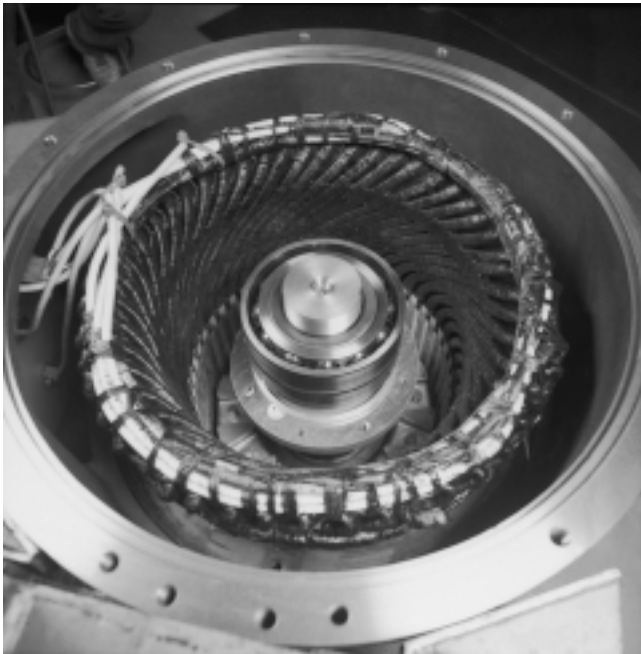


**Figure 15. Installing inner half of thrust bearings.**

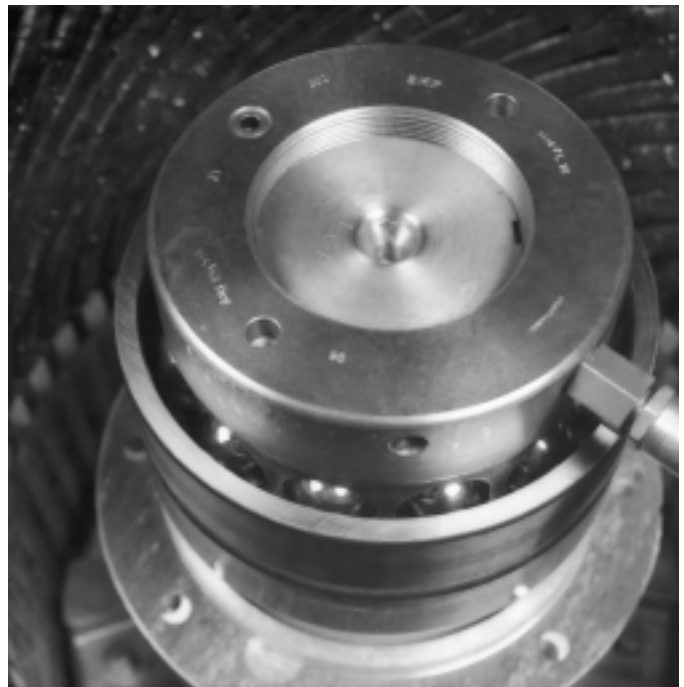
**Note: On newer units, the bearing cap gasket is not used.**



**Figure 16. Installing outer half of thrust bearings**

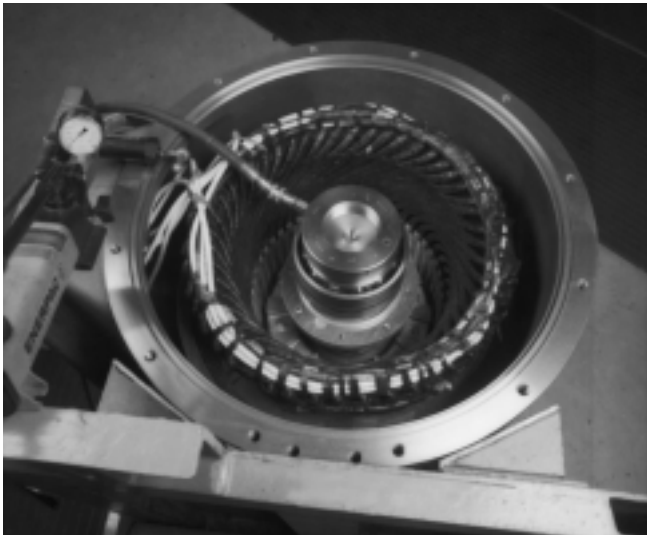


**Figure 17. Installation of hydraulic assembly nut**



**Figure 18. Seating the thrust bearings with hydraulic assembly nut.**

**Note: Skip to Figure 41 for all CVHE, CVHF, and CVHG except extended capacity (CVHF 1470 or CVHF 1720) compressors.**



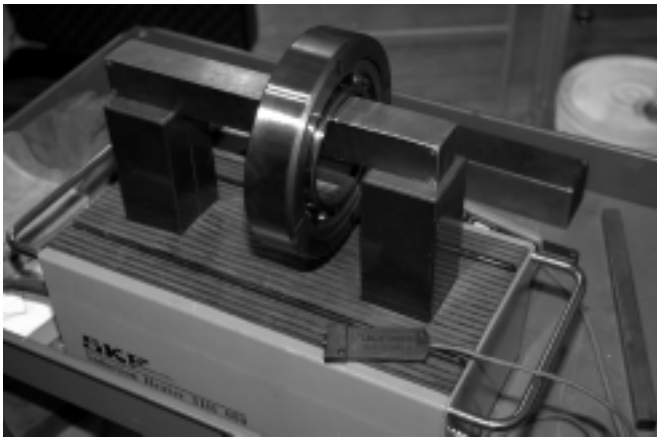
**Figure 19. CVHF 1470 or 1720 motor with thrust bearings removed. The bearing cap is shown in place in preparation for a new thrust bearing installation.**

**Note: A gasket is not used on the bearing cap.**



**Figure 20. Heating the bearing (230°F to 250°F) with an induction heater.**

**Note: If a induction heater is used, a degauss cycle is required to ensure the bearings are not magnetized. Heat the bearings to 230°F to 250°F final temperature before installing them on the shaft.**



**Figure 21. After heating the bearing, slide the first half onto the shaft as shown.**

**Note the center feed grooves in the outer race which provide oil feed to the bearings. The grooves face each other when the two bearings are installed.**



**Figure 22. Install the second bearing of the back-to-back thrust bearings in a similar manner as the first bearing.**

**Note: The oil grooves on the outer race of each bearing must face one another but do not have to align with each other.**



**Figure 23. Outer race alignment markings, if present, should form a complete "V".**

**Note: Starting in 2002, alignment markings will not be used on the thrust bearings so no particular alignment of the two bearings is required, other than a back-to-back arrangement.**



**Figure 24. TOL01550 - Required for CVHF 1470 and CVHF1720 compressors. This tool contains the hardened spacer, threaded shaft extension, hardened washer and cap screw.**



**Figure 25. Using TOL01550, install the threaded shaft extension on the shaft using the long cap screw and hardened washer as shown.**



**Figure 26.** Use air impact wrench to tighten the cap screw on the shaft extension. Torque to 150 - 200 Ft. - Lbs.



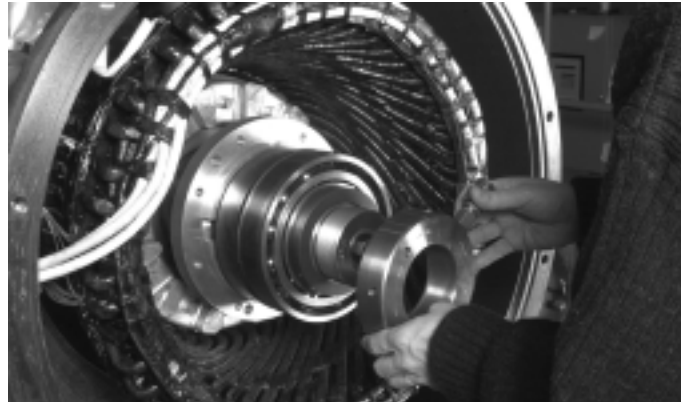
**Figure 27.** Install hardened spacer ring from TOL01550 with the raised face toward the bearings.



**Figure 28.** Install the hardened spacer ring as shown. The raised face of the ring goes against the bearing inner race.



**Figure 29.** Install the hydraulic assembly nut (NUT0730) on the threaded extension.



**Figure 30.** Hand tighten the hydraulic assembly nut using the rod provided with the nut.



**Figure 31.** Bleed the hydraulic nut and hose assembly to remove all air from the system.



**Figure 32. Pressurize the hydraulic assembly nut to 2700 to 2800 psi. Release the pressure at the pump and remove the hydraulic assembly from the shaft. Remove the hardened spacer and the shaft extension from the shaft.**



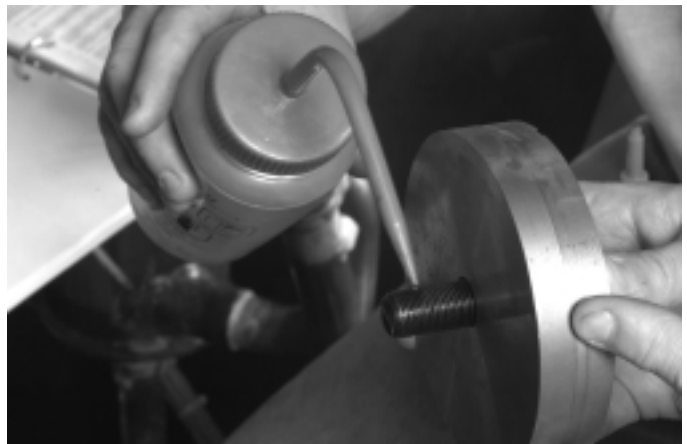
**Figure 33. Lubricate the washer and direct tension indicator with OIL022 before installation on the cap screw.**



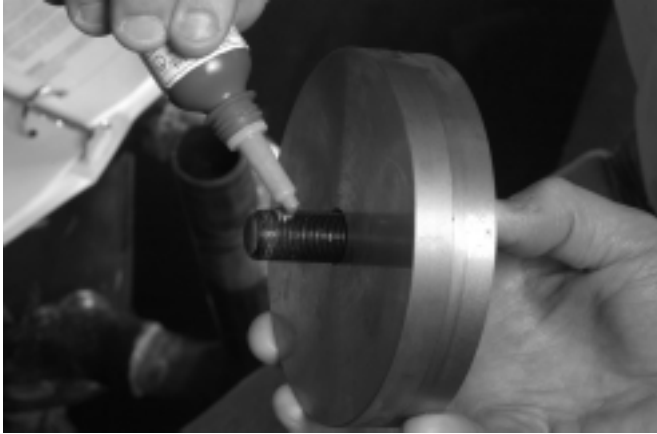
**Figure 34. Large bearing retention washer and KIT07314, which contains a bellville washer, direct tension indicator, small hardened washer, cap screw and three feeler gauges (.005, .010, .015 narrow tip). (Not shown)**



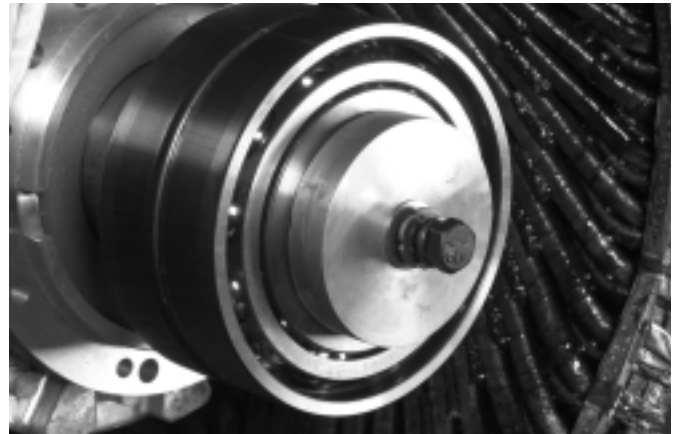
**Figure 35. Clean the threads of the cap screw with acetone or equivalent degreaser.**



**Figure 36.** Apply 1 to 5 drops of LocTite 242 on the threads of the cap screw to insure retention.



**Figure 37.** Install the large washer, belleville (spring) washer, direct tension indicator, small hardened washer and cap screw as shown finger tight. Make sure the protrusions of the DTI (direct tension indicator) are facing the small hardened washer. A torque setting of 160 - 200 Ft. - Lb. should be used if available. Tighten the screw until the average of all gaps as measured between the hardened washer and DTI is .015" to .020", with no individual gap greater than .025" or less than .010".



**Figure 38.** Narrow tipped feeler gauges. These are standard feeler gauges which were cut at the tips to allow measurement of the direct tension indicator clearance while torquing the cap screw. Note: KIT07314 provides similar gauges in .005, .010 and .015" - narrow tip.



**Figure 39.** After applying torque with an impact wrench to the cap screw, measure the gap of the direct tension indicator and hardened washer in all 5 places. The average of all gaps must be .015" to .020", with no individual gap greater than .025" or less than .010". If a gap is greater than .025", tighten again using the impact wrench and repeat the measurement. If a gap falls below .010", remove the cap screw and washers and install a new KIT07314. Repeat the above procedure.



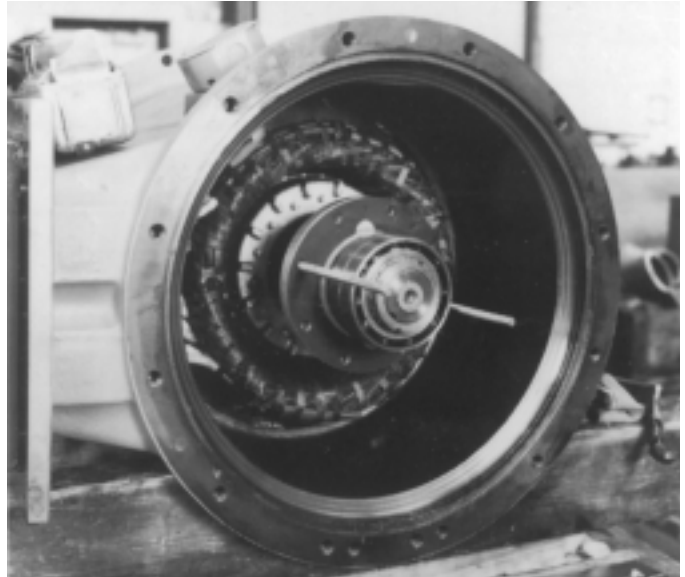
**Figure 40. Example of 5 gap readings which average out to .019" and fall within minimum and maximum individual gap specifications.**

**Note: Slot in face of large retention washer is not used in production.**

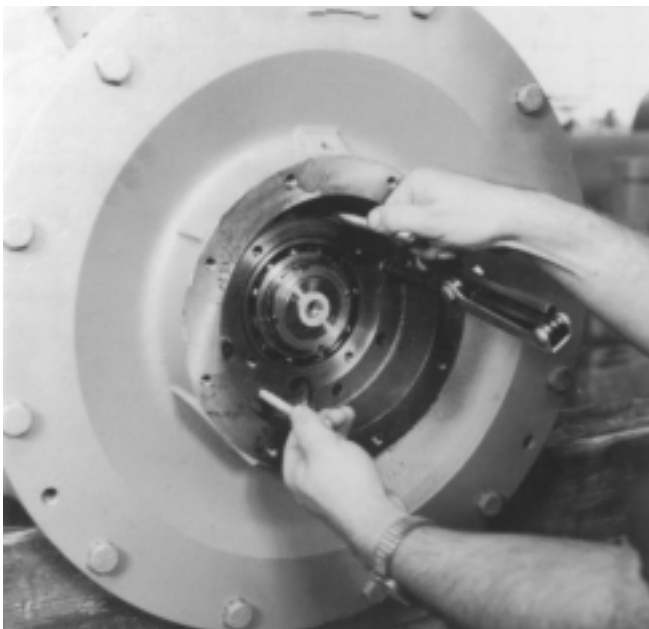


**Figure 41. Installing opposite drive end bearing seal.**

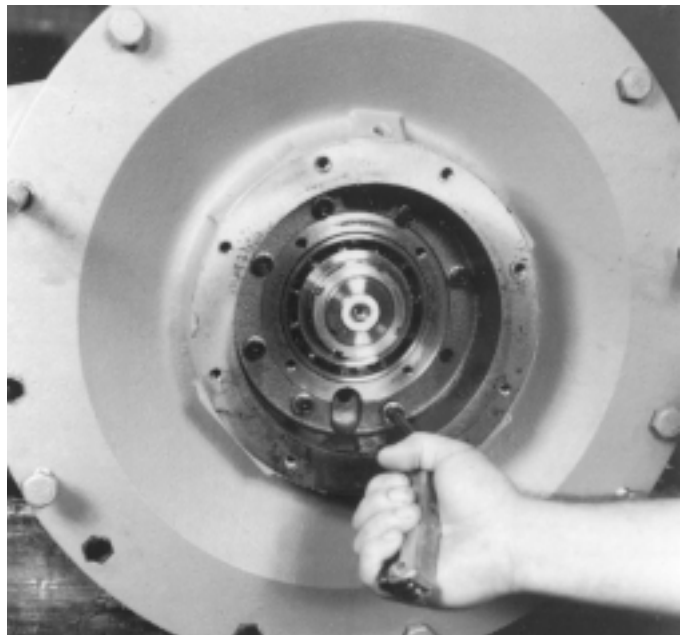
**Note: For center feed bearing design, the bearing cap gasket is not used.**



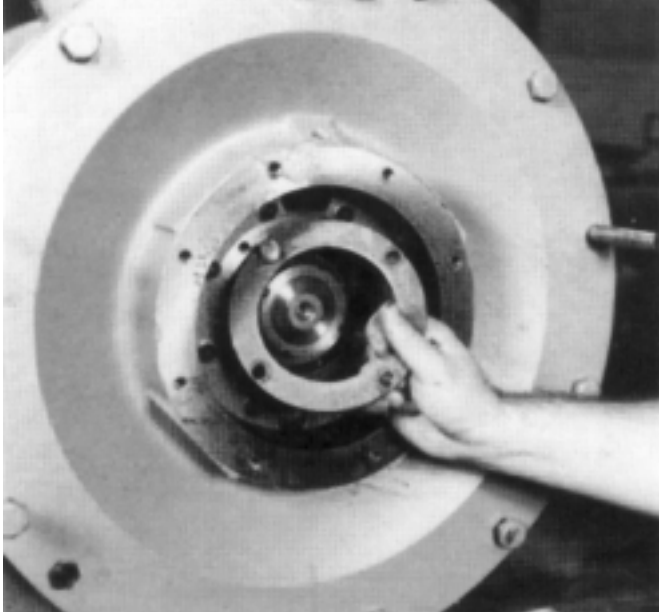
**Figure 42. Installing opposite drive end bearing bracket.**



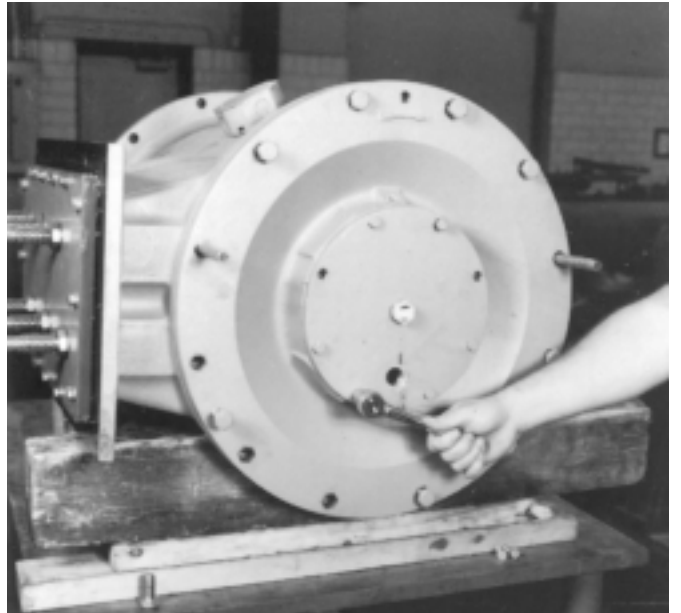
**Figure 43. Tightening inner bearing seal retaining bolts.**



**Figure 44. Bearing retaining ring.**



**Figure 45. Installing opposite drive end bearing inspection cover.**



Using the jack-bolt holes, remove the bearing bracket. The bearing bracket must be separated from the outer ball bearing race. The bearing bracket weight must be supported from overhead (use a chain hoist or similar). Separate the bearing bracket from the bearing race using a gentle back and forth rocking action. As the bracket is removed it will drop slightly as the sealing surface is cleared (when the bracket has been moved out approximately 1/2-inch). Once the sealing surface is cleared the bearing bracket can be lowered until the rotor rests on the stator. See Figure 9a, 9b or 9c. Extreme care must be exercised to prevent the bracket from jamming on the bearing and to prevent movement of the rotor assembly which could in turn damage the stator assembly. Remove the bearing bracket completely.

For 1470/1720 compressors see Figure 19.

8. Remove the thrust bearing lockwasher and locknut. Refer to Figures 10 and 11. Bend back the lockwasher tab and then use an impact wrench and socket tool to drive off the locknut.
9. Remove the thrust bearing. Refer to Figure 12. Use a bearing puller tool. The puller must pull on the inner race of back bearing to prevent damage to the bearing and shaft. Important items to remember when pulling the bearing are:
  - a. The puller must be square with respect to the shaft.
  - b. The puller must pull on the inner race. It will be necessary to place 0.050-inch shims between the puller and bearing to accomplish this.
  - c. The bearing must not be allowed to drop on the shaft or puller. A cloth rag should be used to protect the bearing.
  - d. Never heat the bearing to remove it since this may damage the bearing or the motor.
  - e. The weight of the puller must be supported by a sling and chain fall.
10. Remove the inner bearing cap (seal). See Figure 13. Exercise care to prevent damaging the gasket. Notice that there is an oil drain hole at the bottom of the seal for non center feed caps. Center feed does not use a drain hole in the cap. No gasket is used with center feed at Bearing cap. This must be plainly marked to insure that the seal is reinstalled with the drain hole at the bottom. The notch in the bearing cap must be positioned at the top when facing the motor.

## Reassembly

1. Go to the OPPOSITE DRIVE END of the compressor motor. Place the OPPOSITE DRIVE END inner bearing cap with a new gasket on the motor shaft. Make certain the oil drain hole in the cap is at the bottom and the notch is at the top (Figure 13).
2. When changing a CVHE, CVHF, CVHG thrust bearing assembly, it is critical to determine what shaft design is present. The only sure way to determine what shaft is present is to examine the thrust bearing end of the shaft and see if a "K4" is stamped there. The "K4" stamped in the end of the shaft may vary in size from 1/4" high to 1/16" high so it may be difficult to see it through the sight glass in the bearing inspection cover. If the motor shaft has not been changed the design sequence can be used to determine what shaft type is present. After determining the shaft design, use the appropriate procedure described as follows:

## CAUTION

### Equipment Damage

**Use extreme care in order to avoid damage to the shaft shoulder and journal during thrust bearing removal. Failure to do so could cause shaft to be replaced or reworked due to fretting or other damage.**

Great care must be taken to avoid damage to the shaft shoulder and journal during thrust bearing removal. After the thrust bearings are removed, examine the shaft for signs of excessive wear or fretting, especially at the shaft journal and shoulder. The shaft should be measured at the journal O. D. to insure that the shaft is in tolerance. This will require a calibrated micrometer which is capable of reading 0.0001". If the shaft condition is in question, call the CenTraVac Technical Service department in La Crosse for assistance.

### Non-"K4" Marked Shaft

The following bearings will be required for a non-"K4" marked shaft:

Shaft Size	Part No.	<u>"K-4" Shaft Journal Dimensions</u>
Small diameter (2.16" Bore)	BRG0913	2.1650" to 2.1655"
Large diameter (3.54" Bore)	BRG0914	3.5429" to 3.5434"

## CAUTION

### Equipment Damage

**These bearings can only be used with a non- "K4" Marked Shafts!**

These bearings have a small inner race I. D. which gives a press fit of 0.0002" to 0.0011" with a non "K4" shaft.

**Note:** These bearings come with a new lockwasher and locknut.

## "K4" Marked Shaft

The following bearings will be required for a "**K4**" marked shaft:

Shaft Size	Part No.	Non-"K4" Shaft Journal Dimensions
Small diameter (2.16" Bore)	*BRG01209	2.1656" to 2.16661"
Large diameter (3.54" Bore)	*BRG01210	3.5435" to 3.5440"
1470/1720 Extended Capacity (3.74" Bore)	**BRG01258	3.7404" to 3.7409"

**\*Note:** These bearings come with a new lockwasher and locknut.

**\*\*** Requires KIT07314 for installation (see Figure 34).

## Installing the Bearings:

**Beginning in 2002 high spot marking to the thrust bearings are not used. No special alignment of the bearing to each other is required except insuring that they are in a back-to-back arrangement when high spot markings are not present.**

**Note:** Use either Step 3 or Step 4 depending on bearing manufacturer, DO NOT USE BOTH STEPS WHEN INSTALLING THE BEARINGS!

Only matched bearing sets shall be installed on the motor shaft as shown in Figure 14. A matched bearing set will have the same numerical serial number but one of the bearings will have a letter following the serial number. The bearing set should not be washed unless absolutely necessary. If the bearings are washed, great care must be taken to insure cleanliness of the solvent and washing container.

The bearing set should be heated uniformly to a final temperature of 230°F to 250°F. If a induction heater is used, the bearings should be demagnetized before installation on the shaft. A maximum of 5 gauss magnetism is allowable. A hand held gauss meter can be used to measure residual magnetism.

### 3. Mounting NTN Bearings:

**Note:** If NTN bearings have the half "V" scribed or etched on the outer race O.D., use the SKF Procedure outlined in step 4.

- a. The bearing set shall be mounted on the motor shaft in a back-to-back arrangement (sides of outer races with identification marks should face each other). Install the first half of the bearing set on the motor shaft with the thin side of the outer race facing the rotor until the bearing seats against the shaft shoulder. See Figure 15.
- b. Note the position of the high spot marks on both races of the installed inner half of the bearing set. Rotate the outer race of the installed bearing until the high spot marks line up with each other.

- c. Prior to installing the outer half of the bearing set on the motor shaft, line up the high spot marks on both races. Install the bearing on the motor shaft with the thin side of the outer race facing out of the motor and the high spot marks on both races 160° to 200° away from the high spot marks on the inner half of the bearing. See Figure 16.

#### 4. Mounting SKF Bearings:

- a. Bearing may or may not have alignment marks. If alignment marks are present, one half of a "V" has been scribed or etched on the O.D. of the outer race of each bearing and a line has been scribed across the bore of the inner race of each bearing. When the bearing halves have been properly arranged on the shaft, the halves of the "V" on the O.D. of the outer races will line up to form a complete "V" and the lines in the bores of the inner races will also line up.
- b. The bearing set must be mounted on the shaft in a back-to-back arrangement.
- c. Remove the first half of the bearing set from the heater. Note the location of the scribed line in the bore (if present) of the inner race. Align the inner race scribed line with the keyway of the shaft. Install the first half of the bearing set on the motor shaft with the thin side of the outer race facing the rotor. Allow the bearing to seat against the shoulder on the shaft. See Figure 15.
- d. Rotate the outer race of the installed bearing half unit until its "V" lines up with the scribed line in the bore of the inner race.
- e. Prior to installing the outer half of the bearing set on the motor shaft, line up the scribed line in the bore of the inner race with the half "V" on its outer race. Install the bearing on the motor shaft with the thin side of the outer race facing out from the rotor and both alignment marks lined up with alignment marks on the first bearing. Refer to Figure 16.

5. Seating the Bearings: All CVHE, CVHF, and CVHG units except CVHF 1470 or 1720 extended capacity.

**Note:** The duplex ball bearing alignment sleeve tool is not required for thrust bearing installation and total indicated runout readings for the thrust bearing assembly are not required.

Hold the inner race of the outer bearing against the inner bearing half until the bearing tightens on the shaft. Allow the assembled bearing set to cool to 100°F or less. Install a hydraulic assembly nut on the shaft and hand tighten the piston end of the nut against the outer bearing. Refer to Figure 17. Attach a hydraulic hose to nut, bleed air from system and using a hydraulic pump with a regulator, pressurize the hydraulic nut to 2200 psi to seat the bearings

against the shaft shoulder. See Figure 18. Verify the bearing is seated against the shaft shoulder by trying to put a 0.001 inch feeler gauge between the bearing race and the shaft shoulder. A properly seated bearing will have a .000 clearance. Relieve the pressure from the hydraulic nut, remove the hose from the hydraulic nut, and remove nut from shaft. Install a new tab washer and locknut. Do not use a hammer and spanner wrench to tighten the locknut. Use the proper size socket tool listed in Table 1 and use the following procedures.

6. Torquing of the Locknut: All CVHE, CVHF, and CVHG units except CVHF 1470 or 1720 extended capacity.

Ideally a torque wrench should be used to apply the required torque to the locknut. This may be possible for the small diameter shaft units. For the large diameter shaft, a pneumatic impact wrench will be required to provide the torque required without allowing the rotor to turn in the stator. The following torque value is required.

Small Diameter Shaft - 60 to 80 Ft. - Lb.  
Large Diameter Shaft - 160 to 200 Ft. - Lb.

To obtain an accurate torque value, the following method can be used to torque the locknut when a torque wrench cannot be used.

- a. Install a new tabwasher and lockout, using the following parts:  
These parts should be included with the new bearing set.

<b><u>Small Diameter Shaft</u></b>	<b><u>Large Diameter Shaft</u></b>
Tabwasher - WAS0594	Tabwasher - WAS0595
Lockout - NUT0434	Lockout - NUT0435

- b. Torque the nut to 10% of final torque value using a torque wrench and socket tool. This will require a torque of 6 to 8 Ft. - Lb., for the small nut and 16 to 20 Ft. - Lb. For the large nut.
- c. Mark the nut and inner race in a straight line to act as a reference point. Use a fine tipped marker pen or equivalent.
- d. Mark the inner race in a clockwise direction the following distance from the first mark:

Small Nut: .3" to .5" range  
Large Nut: .5" to .7" range

This will provide a degree of rotation method for torquing the lockout.

- e. Use the appropriate socket tool for the size of nut and pneumatic impact wrench to rotate the locknut until the mark on the nut falls in the range stated in step (d). If a air source is not available, a large cylinder of dry nitrogen with a regular adjusted to 120 psi can be used to power the pneumatic impact wrench. A 3/4" drive wrench will probably be required for the large locknut.
- f. Align a lockwasher tab with a slot in the locknut. Continue tightening the nut to align a tab to a slot. Do not loosen the locknut to align a tab to a slot - always tighten.
- g. Carefully bend the locking tab into the slot in the nut. Be very careful not to pry on the bearing races or cage and take great care to ensure bearing cleanliness. Use a soft material, such as brass or nylon to bend the tab. Be careful that no metal burrs or shavings enter the bearing assembly.
- h. Rotate the outer race of the bearing set to check for free turning. A slight continuous drag is normal due to the built in bearing preload. If difficulty is encountered in rotating the outer races, tap the face of the outer race assembly around the circumference of the outer race using a rubber or rawhide mallet. This should allow free rotation of the bearing assembly.

For CVHF 1470 or 1720 compressors, refer to procedure starting at Figure 19 through Figure 40.

- 7. Install 3/8" -16 threaded rod into the opposite drive end bearing seal. Align the seal so that the oil drain hole is on the bottom. Be sure the gasket is installed and located properly. Refer to Figure 41.
- 8. Install the opposite drive end bearing bracket O-ring (if used) using LocTite 515 "Gasket Eliminator". Lift the bearing bracket using a chain hoist. The bearing bracket should be positioned on the guide rods which were installed in Step 4 of the disassembly section (Page 5) to support the weight. When positioning the bracket, the threaded rod connecting to the inner seal must pass through the bolt holes in the bearing bracket such that the oil drain hole is on the bottom.

Work the bearing bracket into place and secure it with several bolts. The bracket should slide over the bearings with minimal force.

- 9. Install the two roll pins that were drilled for prior to disassembly (or which were factory installed). These pins are necessary for proper relocation of the bracket so that the original compressor seal clearances are re-established. Tighten all bearing bracket bolts to 150 Ft. - Lb.

10. Refer to Figure 42. Set the inner seal by installing the socket head capscrews. Properly installed the outer race of the bearings should extend approximately 1/16" beyond the bearing bracket. If not, the bearing seal is not properly seated and the bearing will be allowed to float. This will result in serious compressor damage. Reposition the seal if necessary. Tighten the retaining bolts to 24 Ft. - Lb.
11. Install the bearing retaining ring and bolts, then tighten to 24 Ft. - Lb. See Figures 43 and 44. This retaining ring provides a clamping force on the bearing outer race to prevent it from rotating.
12. Install the opposite drive end inspection cover. Be sure and use LocTite 515 on the O-ring (if present) and outboard flange. See Figure 45.
13. Reassemble the bearing oil supply and drain lines. **If the lines were cut, use a copper coupling and soft solder to reconnect these lines, such as StayBrite silver bearing solder (96% tin, 4% silver) or 95-5 solder (95% tin, 5% antimony). These solders melt and flow in the 430°F to 465°F range. Do not over flux these joints.**

**Note:** (Use paste flux and not liquid acid flux). If these joints are brazed rather than soldered, it is absolutely mandatory to purge the lines with an inert gas while brazing. The preferred method is soldering.
14. Pressurize and leak test the chiller.
15. Air run chiller and take vibration readings per CVHE-SB-18 to insure unit meets vibration specifications. If the vibration levels are out of specification, a trim balance will be required.

## Parts Information:

The following parts shown in Table 1 are required to allow a duplex ball (thrust) bearing set to be installed. See Figure 46 for example of hydraulic assembly nut, hose and hand pump assembly complete.

**Table 1**

<b>Qty</b>	<b>Description</b>	<b>Manufacturer/Part No.</b>	<b>Trane Part No.</b>
1	Hydraulic Hose 6' Long -10,000 psi 3/8" NPT Male x 1/4" NPT Male	ENERPAC H870	HSE0363
2	Coupler - Female Hydraulic 1/4" N PT M	ENERPAC 3050-2	CPL0392
1	Coupler - Male Hydraulic 1/4" NPT F	ENERPAC 3010-1	CPL0393
2	Adaptor -1/4" NPT Female x 0.25" BSAT Male	ENERPAC F3HG	ADP0371
1	Hydraulic Assembly Nut-Small Bearing	SKF HMVC-11	NUT0729
1	Hydraulic Assembly Nut-Large Bearing	SKF HMVC-18	NUT0730
1	Socket for Large Locknut 1/2" Drive	WHITTET-HIGGINS BAS-11	TOL194
1	Socket for Large Locknut 3/4" Drive	WHITTET-HIGGINS BAS-18	TOL193
1	Hydraulic Hand Pump Assembly	See Figure 47	
1	CVHF 1470, 1720 Installation Tools	See Figure 24	TOL01550

The hydraulic assembly nuts require the installation of adapter ADP0371 to provide a fitting for attaching a quick coupler. This will require removal of the coupler fitting provided on the assembly nuts from SKF. This is a British thread and requires the use of a copper gasket when installing the adapter into the assembly nut. Install a coupler fitting into the 1/4" pipe fitting of the adapter on the assembly nuts (CPL0392). This will allow quick change out of the hydraulic nuts when going from one size to the other.

Attach the coupler (0.25 NPTF) CPL0393 to the male NPT connection on the hydraulic hose (HSE0363) as shown on Figure 46. The 0.375 NPT end of the hose attaches to the relief valve fitting of the hand pump assembly (No. 13 on Figure 47). A 0.375 coupler can be used to allow easy hose removal for transport, if desired.

## Hydraulic Hand Pump Assembly:

The parts required for the hand pump assembly are given in Table 2. Before anything is connected to the Enerpac P141 hand pump, the tank return kit tie rod must be installed in the P-141 pump. This will require removing the hydraulic oil from the pump, removing the acorn nut on the end cap and removing the tie rod by unscrewing from the pump housing. Install the tie rod from the tank return with the slotted end thread protruding through the end cap. This will allow the hydraulic oil to return to the tank. When installing the fitting on the rod end (Item 12 on Figure 47), torque to 15-19 Ft. - Lb. Be sure to install the copper washer on the tie rod end before installing the fitting. Use a good grade pipe sealant that is compatible with hydraulic oil for all pipe thread joints.

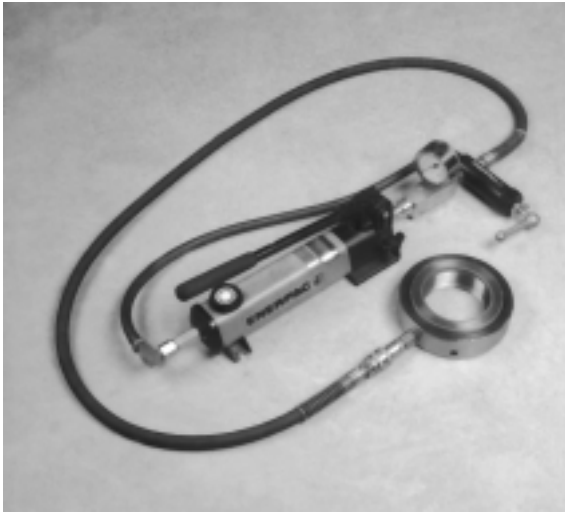
**Note:** An alternative to Item 12 can be fabricated by using the adapter provided in the tank return kit (7/16" NC female x 7/16" NF female) and 1/4" NPT high pressure coupling. Weld the pipe coupling on the fine thread end of the adapter provided in the return kit. This will provide a 7/16" NC female to 1/4" NPT female fitting.

**Table 2**

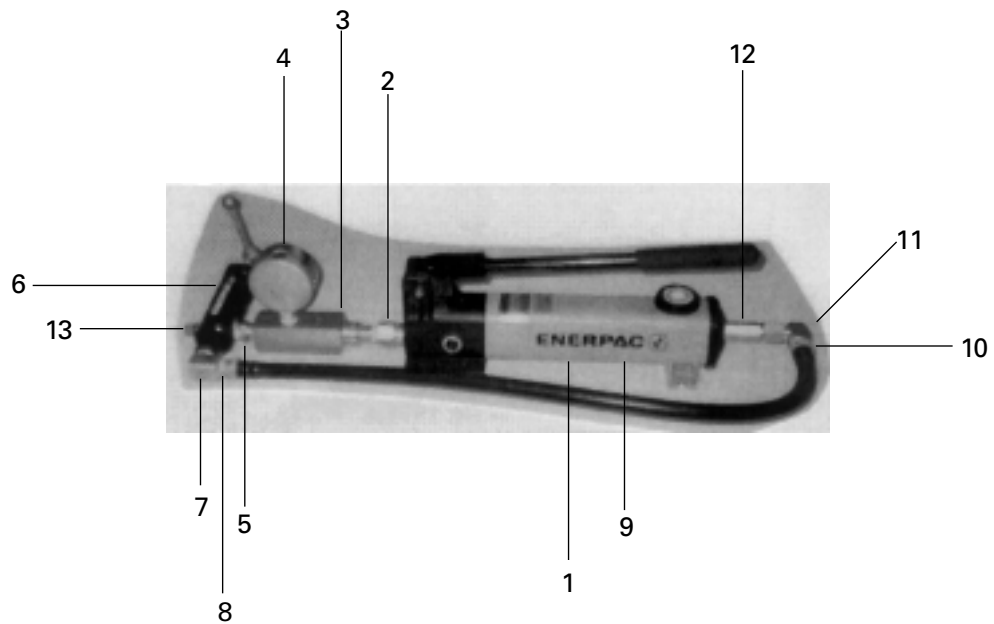
**Hand Pump Assembly Parts**

Item	Description	Manufacturer/Part No.	Trane Part No.
1	Hydraulic Pump with Tank Return Kit	ENERPAC P141 ENERPAC PC-20	PMP0666 ADP0368
2	Adaptor - 0.25 NPT Male x 0.375 NPT Female	ENERPAC FZ1055	ADP0369 3
	Gauge Adaptor	ENERPAC GA3	GAGO154
4	Gauge - Hydraulic 1 0,000 PSI	ENERPAC 25-300	GAGO155
5	Connector - 0.375 NPT Male Straight	AEROQUIP 2083-6-6S	CON0480
6	Relief Valve	ENERPAC V-152	VAL4474
7	Elbow - 90° 0.375 NPT Male x 0.375 NPT Male	AEROQUIP 2089-6-6S	ELL0319
8	Hose Barb - Swival x 0.375 NPT Male	AEROQUIP FJ9068-0606S	FTGO135
9	Hose - Rubber 3/8" ID	Gates 6LOR 3/8" - Lockon	
10	Hose Barb - 0.25 NPT Male	AEROQUIP 4738-4-6B	FTGO136
11	Elbow - 90° 0.25 NPT Male x 0.25 NPT Female	AEROQUIP 2089-4-45	ELL0320
12	Coupler 0.25 NPT Female x 7/16" - NC Female		CPL0395
13	Outlet Port 0.375" NPT Female for Hydraulic Hose Conn.		

**Figure 46. Example showing hydraulic assembly nut, hose and hand pump assembly**



**Figure 47. Showing location of parts on a Trane hand pump assembly**



**Trane**  
 A business of American Standard Companies  
[www.trane.com](http://www.trane.com)

For more information contact your local Trane office or e-mail us at [comfort@trane.com](mailto:comfort@trane.com)

Literature Order Number	CVHE-SB-33B
File Number	SL-RF-CTV-CVHE-SB-33B
Supersedes	CVHE-SB-33A
Stocking Location	Electronic Only

Trane has a policy of continuous product and product data improvement and reserves the right to change design and specifications without notice. Only qualified technicians should perform the installation and servicing of equipment referred to in this publication.