



# General Service Bulletin

## Set-up Guide and General Troubleshooting Information for S811/S811+ Solid State Starter On Trane CenTraVac Chillers

---

**ATTENTION:** Warnings, Cautions and Notices appear at appropriate sections throughout this literature. Read these carefully:

**⚠ WARNING** Indicates a potentially hazardous situation which, if not avoided, could result in death or serious injury.

**⚠ CAUTION** Indicates a potentially hazardous situation which, if not avoided, could result in minor or moderate injury. It could also be used to alert against unsafe practices.

**NOTICE:** Indicates a situation that could result in equipment or property-damage only accidents.

---

### Introduction

Beginning in August of 2009, Trane-supplied Eaton®/Cutler-Hammer® Solid State Starters provided with CenTraVac™ chillers were equipped with Eaton's S811 Intelligent Technologies starter.

Beginning in August of 2012, Trane-supplied Eaton/Cutler-Hammer Solid State Starters provided with CenTraVac chillers are equipped with Eaton's S811+ Intelligent Technologies Starter. The S811+ introduces a slightly changed menu structure and more fault relay configuration choices.

The T801 is no longer used.

**This is an informational bulletin.**

**The action described in this bulletin is not being taken to address a safety concern.**

### **⚠ SAFETY WARNING**

Only qualified personnel should install and service the equipment. The installation, starting up, and servicing of heating, ventilating, and air-conditioning equipment can be hazardous and requires specific knowledge and training. Improperly installed, adjusted or altered equipment by an unqualified person could result in death or serious injury. When working on the equipment, observe all precautions in the literature and on the tags, stickers, and labels that are attached to the equipment.

**⚠ WARNING**

**Proper Field Wiring and Grounding Required!**

All field wiring **MUST** be performed by qualified personnel. Improperly installed and grounded field wiring poses **FIRE** and **ELECTROCUTION** hazards. To avoid these hazards, you **MUST** follow requirements for field wiring installation and grounding as described in **NEC** and your local/state electrical codes. Failure to follow code could result in death or serious injury.

**⚠ WARNING**

**Personal Protective Equipment (PPE) Required!**

Installing/servicing this unit could result in exposure to electrical, mechanical and chemical hazards.

- Before installing/servicing this unit, technicians **MUST** put on all PPE required for the work being undertaken. **ALWAYS** refer to appropriate MSDS sheets and OSHA guidelines for proper PPE.
- When working with or around hazardous chemicals, **ALWAYS** refer to the appropriate MSDS sheets and OSHA guidelines for information on allowable personal exposure levels, proper respiratory protection and handling instructions.
- If there is a risk of arc or flash, technicians **MUST** put on all PPE in accordance with NFPA 70E or other country-specific requirements for arc flash protection, **PRIOR** to servicing the unit.

Failure to follow instructions could result in death or serious injury.

## Discussion

**⚠ WARNING**

**Live Electrical Components!**

During installation, testing, servicing and troubleshooting of this product, it may be necessary to work with live electrical components. Have a qualified licensed electrician or other individual who has been properly trained in handling live electrical components perform these tasks. Failure to follow all electrical safety precautions when exposed to live electrical components could result in death or serious injury.

**⚠ WARNING**

**Motor Terminals Energized Even When Unit Is Not Running!**

The “inside the delta” application of the S811/S811+ starter in a CenTraVac chiller has motor terminals 4, 5, and 6 energized even if the unit is not running. Failure to follow all electrical safety precautions when working on a motor/starter equipped with S811/S811+ could result in death or serious injury.

This bulletin provides information needed for the proper setup and operation of the S811/S811 when applied with Trane CenTraVac chillers.

- S811 Solid State Starters are identified by having a “D” as the 10<sup>th</sup> digit of the Eaton catalog number. For example: S811V65N3**D**.  
If working with an S811 starter, use [Table 1, p. 3](#) for menu settings.
- S811+ Solid State Starters are identified by having a “S” as the 10<sup>th</sup> digit of the Eaton catalog number. For example: S811V65N3**S**.  
If working with an S811+ starter, use [Table 2, p. 3](#) for menu settings.

**Important:** Ensure that a jumper is present between terminals “+” and “3” on the S811/S811+ control terminal block. The S811/S811+ will not operate if this jumper is not installed. Refer to [Figure 1, p. 6](#) and [Figure 2, p. 7](#) for typical S811/S811+ wiring diagrams.

**Note:** If replacing an existing T801 or S811 which has a fan kit installed, remove the fan and reinstall it onto the new S811+ in the same manner. It is recommended that the S811/S811+ always be operated with fans installed.

Prior to initiating a start command for the unit, the S811/S811+ requires several parameter values and/or conditions to be entered into memory. Only 24 Vdc control power is required to enter parameter values into the S811/S811+. Use the following procedure to set parameter values.

### Parameter Entry Procedure

1. Provide 24 Vdc power to the respective “+” and “-” terminals of the S811/S811+.  
After the unit initialization period is completed (approximately 5 seconds), the Display Mode screen, showing Line Current values, appears on the Digital Interface Module (DIM).
2. Press the ESC key once to move to the Parameter Edit mode.  
The first menu displayed will be the Monitoring menu.
3. Press the PREV or NEXT keys to navigate through the Parameter Edit menus.

4. When the desired Parameter menu is displayed, press the ENTER key to move to the Parameter(s) in the selected menu group.
5. Press the PREV or NEXT keys to navigate through the Parameter(s).
6. When the desired Parameter is displayed, press the EDIT key to move to the value edit mode. When in this mode, the parameter and text will be highlighted.
  - a. Pressing the DEC or INC keys to change the parameter values.
  - b. Parameter value entries are categorized by the following:
    - i. Value selection options with options of "0", "1", "2", etc.
    - ii. Value selections that toggle between "0" and "1" (Disable or Enable).
    - iii. Value selections that enter a numerical value (i.e., voltage, etc).
7. Store the value into memory by pressing the SAVE key.

**Note:** Exit any menu without storing values by pressing the ESC key.

When the SAVE key is pressed, the value is stored and the display shows the stored parameter value.

8. Press the PREV or NEXT keys to move to other parameters.
9. When Parameter entry is complete, press the ESC key several times to exit back to the Display Mode screen.

It is recommended that the parameters in the S811 be set to the values shown in [Table 1](#) and parameters in the S811+ be set to the values shown in [Table 2](#).

**Table 1. Trane S811 Parameter value entries**

#	Parameter	Display	Value
<b>Soft Start Config—Menu 3</b>			
1	Start Method	Voltage Ramp	0
2	Soft Start Time	Seconds	20
3	Initial Torque	%	35
4	Pump Stop Time	Seconds	0
5	Soft Stop Time	Seconds	0
6	Kick Start Time	Seconds	0
7	Kick Start Torq	%	0
8	Start Control	Level	1
9	Reset Mode	Auto	1
10	Relay 1 Config	Bypass	2
11	Relay 2 Config	See Note below.	

**Note:** For Trane® starters with model number design sequence **C** and earlier and that do not have shorted SCR detection and shunt trip capabilities, set the Relay 2 Config to be **Not Faulted 1**; for Trane® starters with model number design sequence **D** and later and that do have the shorted SCR and shunt trip capabilities, set the Relay 2 Config to be **SCR Shorted Fault 6**.

**Table 1. Trane S811 Parameter value entries (continued)**

#	Parameter	Display	Value
<b>Overload Config—Menu 4</b>			
1	Overld Trip FLA	Amps	234A 311A 415A 526A 623A 727A 865A 1125A 1246A 1471A 623A 727A 866A
			S811R13N3D S811T18N3D S811T24N3D S811T30N3D S811V36N3D S811V42N3D S811V50N3D S811V65N3D S811V72N3D S811V85N3D S811U36N3D S811U42N3D S811U50N3D
2	Overld Trip Class		30
3	Overload Fault		Enabled
4	Ovld On Start		Enabled
<b>Protection Setup—Menu 5</b>			
1	Phase Sequence	ACB	1
2	Phase Rev fault		Enabled
3	Motor Rated Volt	Volts	See starter model number for voltage.
4	Low Volt Trip		Enabled
5	Low Volt Level	%	30
6	Low Volt Trip Dly	Seconds	3
7	Hi Volt Trip		Enabled
8	Hi Volt Level	%	120
9	Hi Volt Trip Dly	Seconds	3
10	V Imbal Trip Lev	%	30
11	V Imbal Trip Dly	Seconds	5
12	Phase Loss Fault		Enabled
13	Phase Loss % Trip	%	40
14	Phase Loss Trip Dly	Seconds	0.5
15	Low I Trip % FLA	%	1
16	Phase Imb Fault		Enabled
17	I Imbal Trip Lev	%	50
18	I Imbal Trip Dly	Seconds	5
<b>LCD DIM Setup—Menu 8</b>			
23	Clear Fault Que	Clear Fault Que	SEND

**Note:** For all other S811 parameters, use default values unless instructed otherwise by Trane Technical Support.

**Table 2. Trane S811+ parameter value entries**

#	Parameter	Display	Value
<b>S811+ Soft Start Config—Menu 2</b>			
1	Overld Trip FLA <sup>(a)</sup>	Amps	(234) (311) (415) (526) (623) (727) (865) (1125) (1246) (1471)
			135 S811+R13N3S 180 S811+T18N3S 240 S811+T24N3S 300 S811+T30N3S 360 S811+U36N3S 420 S811+U42N3S 500 S811+U50N3S 650 S811+V65N3S 720 S811+V72N3S 850 S811+V85N3S
2	Ovld Trip Class		30
4	Phase Sequence	ACB	1

**Table 2. Trane S811+ parameter value entries**

#	Parameter	Display	Value
5	Start Method	Voltage Ramp	0
6	Initial Torque	%	35
7	Soft Start Time	Seconds	20
12	Reset Mode	Auto	1
15	Motor Wiring Config	Inside Delta	1
<b>Protection Setup—Menu 3</b>			
3	Motor Rated Volt	Volts	Mains Voltage
5	Low Volt Level	%	30
8	Hi Volt Level	%	120
10	V Imbal Trip Lev	%	30
11	V Imbal Trip Dly	Seconds	5
13	Phase Loss % Trip	%	40
16	Low I Trip % FLA	%	1
19	I Imbal Trip Lev	%	50
20	I Imbal Trip Dly	Seconds	5
<b>Advanced I/O Setup—Menu 4</b>			
4	Relay Config		
	Entry 0 (terminals 13, 14)	Bypassed	3
	Entry 1 (terminals 95, 96, 98)	Custom FLT/Warn NOT	9
5	Relay Custom Config	Shorted SCR	59
<b>LCD DIM Setup—Menu 8</b>			
23	Clear Fault Hist	Clear Fault Hist	SEND

(a) Ovld trip FLA is set to the frame size maximum for inside the delta applications. With Menu 2 parameter 15 set to "Inside Delta," set the Ovld trip FLA to the value shown in parentheses. For all other S811+ parameters, use default values unless instructed otherwise by Trane Technical Support.

**Notes:**

- The eight communication dip switches below the DIM (Labeled 1–32, S1, S2) should be positioned in the OFF position.
- The Channel Status LEDs (1 and 0) on the S811 are not used in the Trane system.
- A RED Status LED on the S811 indicates that there is an active fault in the system. The starter will not recognize a START command unless the Status LED is GREEN.
- The SEND command in the Clear Fault Cue only clears the fault history memory; it does not attempt to reset a fault.

## S811 Shorted SCR Detection

Beginning with units shipped in November 2011, Eaton IT S811 solid state starters in Trane-provided starter assemblies have the capability of connecting to the shunt trip input of a circuit breaker or molded case switch, and will command the breaker or switch to open if the S811 detects a shorted SCR or welded bypass contactor inside of the S811. This feature can provide additional protection to the motor in the event of an S811 failure.

Trane-provided unit-mounted, remote-mounted, or wall-mounted solid state starter assemblies that are factory-

capable of providing this protection have a design sequence of **D** and later. Check the 10<sup>th</sup> digit of the starter's Trane service model number to determine the design sequence. Starter assemblies with a **D** or later as the 10<sup>th</sup> digit have a shunt trip equipped breaker or molded case switch provided along with the updated S811.

Example of a Trane-supplied solid state starter service model number with a **D** design sequence:

**CVK0618FDV20000AA0C1**

## Wiring

When a S811/S811+ with shunt trip capability is applied along with a shunt trip equipped breaker or molded case switch, a jumper is installed across terminals J2-1 and J2-2 of binary input LLID 2A5 of the chiller controls. With the jumper installed—and if the S811/S811+ faults for any reason—the chiller will stop, but the chiller controls will not be able to call out that a starter fault diagnostic has occurred in the S811/S811+. Instead, the chiller control is most likely to call out that a phase loss, power loss, or other power related diagnostic has occurred.

The wiring for the shunt trip signal from the S811/S811+ to the shunt trip coil of the breaker or molded case switch is connected across terminals 95 and 98 (normally open) of the control terminal block of the S811/S811+. If a shorted SCR condition is detected by the S811/S811+, it will close the contacts between 95 and 98 and allow power through to the shunt trip coil, opening the breaker or molded case switch. Refer to [Figure 2, p. 7](#) for a typical S811/S811+ wiring diagram that includes the shunt trip capability.

## S811 Shunt Trip

**Note:** In the event that the S811/S811+ has caused a shunt trip of the breaker or switch to occur, it will not be possible to reset the S811/S811+ before resetting the breaker. The S811/S811+ will hold its fault code and state and cause the breaker or switch to shunt trip until the S811/S811+ is reset.

In the event of an S811/S811+ shorted SCR that has caused a shunt trip event and tripped the breaker or switch, a visual inspection of the S811/S811+ exterior and of the connecting lugs will sometimes reveal signs of overheating and physical damage.

**Important:** If damage is visible, do NOT attempt to reset or restart the S811/S811+.

If a shunt trip event has occurred but the S811/S811+ does not show visible signs of damage, check the S811/S811+ for integrity using the following procedure:

1. Remove the line and/or the load power leads from the S811/S811+, so that it is isolated from the circuit.
2. Test continuity over the internal SCR Bridge of the S811/S811+:
  - Use an ohm meter.

- Test the resistance across each leg of the S811/S811+: from L1 to T1, from L2 to T2, and from L3 to T3.
  - Reverse the meter's lead polarity and repeat the test: from L1 to T1, from L2 to T2, and from L3 to T3.
3. The resistance measured across each leg of the S811/S811+ should be a high value, typically 10 kOhm or greater. The resistance measurements across each of the legs should also be fairly close in value to each other. A very low or no resistance measurement is an indication of a shorted SCR or welded internal bypass contactor, and the S811/S811+ should be replaced.

### Resetting a Circuit Breaker or Molded Case Switch provided with a shunt trip input and employing an Eaton Intelligent Technologies S811/S811+ Solid State Starter

#### WARNING

##### Live Electrical Components!

During installation, testing, servicing and troubleshooting of this product, it may be necessary to work with live electrical components. Have a qualified licensed electrician or other individual who has been properly trained in handling live electrical components perform these tasks. Failure to follow all electrical safety precautions when exposed to live electrical components could result in death or serious injury.

If the S811/S811+ has caused a shunt trip of the breaker or molded case switch and a visual inspection of the S811/S811+ does not reveal any damage, and if the tests of the internal SCR bridge of the S811/S811+ do not indicate that the S811/S811+ has failed, then resetting the S811/S811+ may be possible.

**Note:** *Reset the S811/S811+ only if all tests and observations indicate that the S811/S811+ has not failed.*

To reset the S811/S811+ after it has caused a shunt trip event, it is necessary to provide a source of control power to the S811/S811+. If the control power to the unit is from the same line source disconnected by the breaker or molded case switch, connect an auxiliary power supply to power up the S811/S811+.

A second method is to disconnect the shunt trip wiring from the breaker or molded case switch, and then reset and close the breaker or molded case switch to provide line and control power.

#### NOTICE:

##### Equipment Damage!

Be observant for motor current draw on any of the three phases when the breaker or switch is closed, if current flow is observed then immediately manually reopen the breaker or switch and retest the starter and motor. If a shorted SCR or welded internal bypass is present within the S811/S811+, then re-applying line power without the shunt trip wiring intact could result in an extended single phase condition and possible motor damage.

Once a continuous source of control power is provided to the S811/S811+, the shorted SCR or welded internal bypass fault can be reset by using the operator display that is provided on the S811/S811+.

**Figure 1. Typical schematic wiring diagram—Simplex or Duplex—Unit-mounted low voltage S811/S811+ solid state starter**

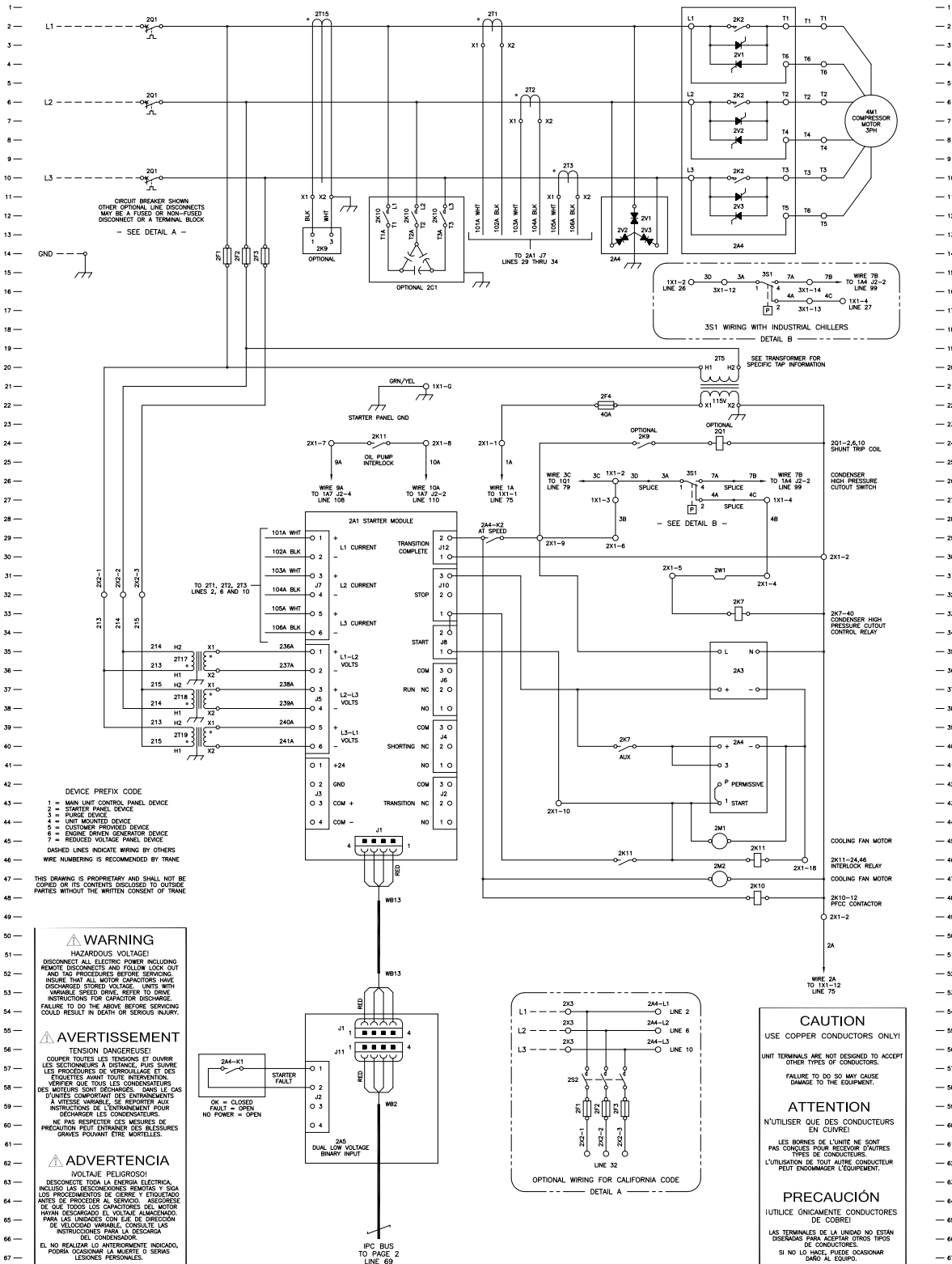



# Eaton S811/S811+ General Troubleshooting Guide

## Troubleshooting Faults, Start Commands, and Status LEDs

### ⚠ WARNING

#### Hazardous Service Procedures!

The maintenance and troubleshooting procedures recommended in this manual could result in exposure to electrical, mechanical or other potential safety hazards. Always refer to the safety warnings provided throughout this manual concerning these procedures. Unless specified otherwise, disconnect all electrical power including remote disconnect and discharge all energy storing devices such as capacitors before servicing. Follow proper lockout/tagout procedures to ensure the power can not be inadvertently energized. When necessary to work with live electrical components, have a qualified licensed electrician or other individual who has been trained in handling live electrical components perform these tasks. Failure to follow all of the recommended safety warnings provided, could result in death or serious injury.

- Control Power – Terminal Block Connections – Trane application

- In a stand-by or run mode, 24 Vdc should be present on the **+** and **3** terminals of the IT S811/S811+. The **+** and **3** terminals should be jumpered together at the S811/S811+ control terminal block. Measure between **+** and **-**, and between **3** and **-** on the S811/S811+ control terminal block to confirm that 24 Vdc is present on these points. If voltage is not present on both of these points, check the jumper wire, fuses, wiring, the 24 Vdc power supply, the unit's HPC circuit, and relay 2K7.
- When the S811/S811+ is commanded to start and run, 24 Vdc is applied by the chiller's starter module to the S811/S811+ **1** and **P** terminals. The **1** and **P** terminals should be jumpered together at the S811/S811+ control terminal block. Confirm this 24 Vdc signal appears by measuring from **1** to **-**, and from **P** to **-**. If 24 Vdc is not found and maintained on both of these points when a start and run is called for, check the jumper wire, the starter control wiring, relay 2K11, and the starter module.
- The chiller starter module commands the S811/S811+ to stop by removing the 24 Vdc signal that is provided to terminal **P**.
- All Trane applications with the S811/S811+ solid state starter should be equipped with a 240-watt, 24-Vdc power supply (Trane part # PWR00155).
- If the **STATUS** LED on the S811/S811+ is red, the unit is faulted and will not recognize any start command.

**Table 3. S811/S811+ control terminal block wiring**

Name	Pin	Function	Input	Connection
Common	-		Negative	- Connect power supply negative to pin - and to system ground
Power	+		24 Vdc	- Connect +24 Vdc output to pin +
Permissive	P	STOP	24 Vdc Maintained	Pin <b>P</b> , permissive, must be energized (+24 Vdc) to enable operation of the unit. If power is removed from the permissive circuit at any time, the unit will begin a STOP command. For the Trane application this terminal is connected by a jumper wire to terminal 1.
Input 1	1	START	24 Vdc Momentary or Maintained	Applying 24 Vdc to Input 1 while P is energized will initiate a START.
Input 2	2	JOG	N/A	Not used by Trane
Input 3	3	HAND/AUTO	24 Vdc Maintained	For the Trane application this terminal is connected by a jumper wire to terminal +.
Input 4	4	RESET	24 Vdc Momentary	Input 4 is Fault RESET. Energizing this input will reset a fault only after the fault condition has been corrected.

- Resetting Faults
  - 24 Vdc control voltage must be present at the S811/S811+.
  - SS cannot be reset with an active fault, STATUS LED = RED
  - To RESET the S811/S811+:
    - Press RESET on DIMM.
    - or
    - Press the recessed manual RESET button of face of the S811/S811+.
    - or
    - Temporarily apply 24 Vdc to Terminal 4 on the S811/S811+ control terminal block.
- S811/S811+ STATUS LED Troubleshooting
  - RED
    - Active fault
  - GREEN
    - If the STATUS LED is green but the unit will not respond to a start command from the chiller, check for insufficient or missing 24 Vdc at the **+** and **3** terminals, and check for an insufficient or missing start-run 24 Vdc at the **1** and **P** terminals.

- OFF
  - Check for loss of 24 Vdc power.
  - Check terminal block for condition and security.
  - Verify 24 Vdc at appropriate terminals.
- Verify 24 Vdc polarity correct.
- Verify proper operation of 24 Vdc power supply.
- If CH0 and CH1 LEDs are flashing on the S811/S811+, possible LED failure.

**Table 4. S811/S811+ fault codes**

Code	Fault	Condition	Solution
1	Firmware Incompatibility or Hardware failure.	Hardware failure	Failed unit. Replace the S811/S811+.
3	Internal Comm.	Communications to DSP have been interrupted. Possible hardware failure.	Firmware is not communicating internally. Cycle 24 Vdc control voltage power to attempt to clear problem. Try a known good display. Try a known good cable (RJ11 phone type) between the display and the S811/S811+.
4	Low Control Voltage	Voltage at Terminal + falls below 17 Vdc. The external 24 Vdc power supply voltage is below specifications and/or insufficient current capacity.	Verify power capacity (amperage) of 24 V power supply to close contactors. Power supply voltage is intermittent and/or drifting. Read value on Monitoring menu. Verify correct wire size (14 gage minimum) used to connect power supply to S811/S811+. Check for wire damage or corrosion. Verify connections are clean and secure. Check voltage drop between power supply and Terminal +. Possible internal hardware failure.

**Notes:**

Only voltage at the + terminal on the Terminal Block is monitored. Depending on how the soft starter is wired, 24 Vdc voltage may be lost at Terminal P just prior to voltage loss at terminal "+ which the soft starter would interpret as a STOP command. This condition would cause a shutdown of the soft starter without logging FC4. Suspect source voltage should be monitored for a significant period of time to determine if the nominal voltage drifts or is intermittent.

When selecting a power supply, ensure that the outrush capacity of the power supply is 240 watts Vdc for 100 ms minimum.

5	Power Pole Over Temperature	SCR temperature is above limits. Operating environment above specified maximum temperature Ventilation holes blocked. Fans are not operational. Starts/hour exceed specifications. Sensor failure on power pole. Bypass contactor(s) failed to close.	Ventilate to specified maximum temperatures Clear obstructions. Verify fans are operational, Verify system is not exceeding the specified maximum starts per hour. Verify bypass contacts are closing at end of ramp time. Excessive cabinet temperature. Soft starter running continuously in JOG mode. (should not apply to Trane applications)
---	-----------------------------	---	---

**Notes:**

Any power pole temperature in excess of 100° C will cause a fault trip. Observe the temperature values in the monitoring menu to verify that they make sense and are reasonably close to each other. If one value is significantly higher than the others, the sensor on the power pole may be suspect. A value significantly lower than the others would indicate a damaged or open sensor lead. Note if the temperature values observed in the Monitoring menu are significantly higher than normal, indicating an actual over heating condition of the power poles and/or the starter in general.

The soft starter will attempt to close the bypass contactors for 30 seconds after the motor is at synchronous speed. If the bypass contactors close, then open, then close, etc. several times, the contactors may be failing to seal electrically. A common report of this condition is that the starter is "chattering". After the 30 seconds expire, the unit will discontinue attempting to close the bypass contactors and will continue to run on the SCRs. At some point in the future, the unit may overheat due to insufficient cooling of the power poles.

If the soft starter is run continuously in JOG mode, the starter will use the normal start parameters BUT the bypass contactors will not close. Running continuously on the SCRs will usually generate more heat than can be dissipated, resulting in an over temperature fault in a given period of time.

6	Phase Loss	Incoming phase disconnected. Open fuse or breaker. Phase imbalance exceeds trip parameter. Severe voltage phase imbalance.	Repair broken connection. Replace fuse. Inspect system for phase imbalance conditions.
---	------------	---	--

**Notes:**

Phase loss is a severe condition of phase imbalance, even momentarily. In cases of severe imbalance causing nuisance trips, this feature may be disabled (not recommended). Prior to disabling this protection, adjust the *Phase Loss % Trip* parameter value (default is 80%) to see if it will improve the condition. Adjusting the *Phase Loss Delay* (default is 0.5 seconds) may also improve performance in cases where phase instability is a problem. Phase performance should be monitored for an appropriate length of time to ensure that the phase is not dropping just long enough for the soft starter to detect the condition.

**Table 4. S811/S811+ fault codes (continued)**

Code	Fault	Condition	Solution
7	Phase Imbalance	The voltage or current imbalance of the incoming phases exceeds the trip threshold.	Correct imbalance problem with mains. Increase the <i>Current</i> and/or <i>Voltage Fault Imbalance</i> parameters. Disable the fault if the other issues cannot be resolved.
<p>Notes:</p> <p>Phase imbalance may be impacted by with voltage issues and/or current issues. This feature may be disabled (not recommended) Current Imbalance Trip threshold range is 1%–100% (default is 40%). Current Imbalance Trip Delay range is 0–60 seconds (default 0.5 seconds). Voltage Imbalance Trip threshold range is 1%–100% (default is 6%). Voltage Imbalance Trip Delay range is 0–10 seconds (default 0.5 seconds). Both Current and Voltage Phase Imbalance features may be disabled (not recommended).</p>			
9	Motor Under Load	Current drawn by the motor is below trip threshold. Failed motor coupling. Load engagement device is not operating. Motor is not loaded to the trip current.	Repair/replace failed couplings. Increase load. Reduce <i>Low I Trip % FLA</i> to an acceptable value (0% will disable).
<p>Notes:</p> <p>This should not occur on Trane CenTraVac applications. When the internal bypass contactors are closed, the average value of the three-phase currents is monitored as a percent of FLA. Low I Trip (Motor Under Load ) threshold range is 1%–100% (default 6%). The Trip delay is 2 seconds, and is not user-settable.</p>			
10	Motor Over Current	Only active in bypass if the Jam Fault is disabled. Current exceeds the fault threshold of 4X catalog FLA.	Check motor drive train. Check compressor.
<p>Notes:</p> <p>This feature is active only with the Jam Fault Trip is disabled, and the internal bypass contactor is closed. This results in a higher current trip threshold in most cases. Monitors the maximum RMS value of the three-phase current. Catalog FLA refers to the maximum continuous line current capacity of the frame size of the S811/S811+, NOT motor rated FLA. Do not confuse this parameter with Instantaneous Over Current (FC18), Thermal Overload (FC14), or SCR Over Current (FC60).</p>			
11	Jam	Soft Starter in Bypass: Motor below rated RPM and/or current exceeds 3X FLA.	Check compressor. Verify proper FLA setting in Protections Menu.  Jam Fault can be disabled if trips occur during normal operation (Over Current Fault will provide protection at a higher current threshold of 4X catalog FLA).
<p>Notes:</p> <p>The Jam Fault may be disabled (not recommended). The maximum RMS value of the three-phase currents is monitored when the internal bypass contactors are closed. The Jam Fault trip threshold is 3 x Motor FLA and is not user-settable. Jam Trip Delay is 1.5 seconds and is not user-settable. This parameter results in a lower current trip threshold than Over Current (FC10) when enabled in most cases.</p>			
13	Bypass Failure	Internal bypass contactor(s) not closed and/or electrically sealed after ramp time. Contactor(s) opened in bypass.  Starter is being operated in JOG mode.	Verify all bypass contactor closure (audible noise).  Verify all bypass contactors not opening due to excessive vibration and/or shock. Reduce shock/vibration. Verify control power and wire size meets specifications. Verify that control power supply meets the 24 Vdc voltage and current requirements of the IT soft starter.
<p>Notes:</p> <p>This fault may occur even is just one contactor (larger units with multiple contactors) fails to seal electrically, or if a contactor drops out. If the firmware detects that the bypass contactors have failed to close (as measured by the voltage drop across the poles, the firmware will command the contactors to release and then reapply the signal to the coil of the contactors. This process will repeat for 30 seconds. After 30 seconds, and the bypass contactors have failed to close electrically, the firmware will discontinue the signal to pull in the contactors and the unit will run off the SCRs. Bypass contactors may open during motor run from excessive shock or 24 Vdc control voltage sag (insufficient voltage and/or current to maintain contact closure). If the IT soft starter is running continuously off the SCRs (JOG mode), pole over temperature fault may occur after a period of time.</p>			

**Table 4. S811/S811+ fault codes (continued)**

Code	Fault	Condition	Solution
14	Overload Fault	Motor overloaded for an extended period of time. Thermal memory at 100%.	Reduce the motor's load. Check compressor.  Verify the <i>Overld Trip FLA</i> , <i>Motor FLA</i> , and/or <i>Ovrld Trip Class</i> for proper adjustment.  Note: Exceeding nameplate ratings will reduce overload protection. Fault during motor start: verify system is not exceeding the specified maximum starts per hour. Increase the initial torque and/or reduce ramp time to bring the motor up to speed faster. Increase Trip Class setting (30 maximum) and/or reduce ramp time setting.
<p>Notes:</p> <p>Normal thermal memory during routine operation may be noted in the <i>Monitoring</i> menu. Higher than normal thermal memory may indicate an abnormal operating condition and signal an impending <i>Overload</i> Fault. After a motor start, the thermal memory should stabilize at a value consistent with the load.</p> <p>After an <i>Overld</i> trip, no restart is allowed until prescribed time period has elapsed. Cycling control power does not reset timer(s).</p> <p>Trip Rest Time Periods  1<sup>st</sup> Trip = 3 minute RESET inhibit.  2<sup>nd</sup> Trip (within 48 minutes of 1<sup>st</sup> Trip) = 6 minute RESET inhibit.  96 minutes to reset to 3 minute inhibit.  3<sup>rd</sup> Trip (within 48 minutes of 2<sup>nd</sup> Trip) = 9 minute RESET inhibit.  144 minutes to reset to 6 minute inhibit.  240 minutes to reset to 3 minute inhibit.  Removing 24 Vdc control power does not reset inhibit times.</p>			
18	Instantaneous Over Current	Excessive starting current. Excessive load.	Reduce starting load. Check compressor motor. Check soft starter capacity settings (be sure model ratings can handle current demands).
<p>Notes:</p> <p>During the Start Ramp Time, the maximum RMS value of the three-phase currents are monitored. Instantaneous Over Current Trip threshold is 6X catalog FLA. The Trip Delay is 1.5 seconds and is not user-settable. Do not confuse this parameter with Over Current (FC10)</p> <p>Catalog FLA refers to the maximum continuous line current capacity of the S811/S811+, NOT motor rated FLA.</p> <p>Do not confuse this parameter with Over Current (FC10), Thermal Overload (FC14) or SCR Over Current (FC60).</p>			
32	Internal NV Memory	Internal memory error.	Component failure on the printed circuit board.
36	Communications Loss	Communications to a remote network controller was lost during run cycle. Device disconnected. Connection lost.	Reattach network controller, verify that the unit is recognized by the system controller.  Repair/replace connection cable. Contact EatonCare® for service.
<p>Notes:</p> <p>This fault should not apply to Trane CenTraVac applications.</p> <p>This fault corresponds only to network communications. It does not relate to internal communications among components on the printed circuit board (PCB).</p>			
38	Temperature Sensor Fault	Temperature sensor failure. Internal connection failure.	Internal hardware failure (sensor and/or cable). Note: Disabling this feature (Temp Sense Fault in Protection Menu) will remove protection from excessive temperature exposure. Not field repairable, contact EatonCare for service.
<p>Notes:</p> <p>There are three independent temperature sensors that incorporate a current sensor on each power pole (phase). This fault may be generated by any one of the sensors. Temperature and/or current values observed in the Monitoring menu should be consistent among each other. Verify that the values of all phase are approximately equal. Sensors are calibrated to the printed circuit board (PCB) and are not field serviceable. The <i>Device Temp.</i> value shown in the Monitoring Menu monitors a sensor mounted directly on the PCB and is not related to the Temperature Sensor Fault. Contact EatonCare for service.</p>			
39	Internal CPU	Firmware Incompatibility or Hardware failure.	Hardware failure on the printed circuit board (PCB) or the firmware is corrupted. Call EatonCare for service.
42	Under Voltage	Incoming AC line voltage below trip threshold. Incorrect mains supply voltage.	Connect to correct supply voltage. Verify that mains voltage is within acceptable values. Verify <i>Motor Rated Volt</i> in the Protection Setup Menu is set to correct value.
<p>Notes:</p> <p>Verify that the value in the <i>Motor Rated Volt</i> parameter is set to line voltage and not to a nominal value. Under Voltage trip level threshold range 1%–99% (default 90%) of line voltage. The Under Voltage Trip delay range is 1–60 seconds (default 3 seconds). This feature may be disabled (not recommended). Verify that the mains voltage levels are not decreasing to unacceptable levels during the start sequence. Verify that the mains voltage levels are not decreasing to unacceptable levels motor during operation. The <i>Motor Rated Volt</i> range is 115 to 690 Vac.</p> <p>MAINS LOW—A similar fault may occur if the incoming mains voltage is less than 80 Vac. This trip threshold is not user-settable.</p>			

**Table 4. S811/S811+ fault codes (continued)**

Code	Fault	Condition	Solution
43	Hi Voltage	Incoming AC line voltage above trip threshold. Incorrect mains supply voltage.	Connect to correct supply voltage. Verify <i>Motor Rated Volt</i> in the Protection Menu is set to the correct value.
<p>Notes:</p> <p>Verify that the value in the <i>Motor Rated Volt</i> parameter is set to line voltage and not to a nominal value. Hi Voltage trip level threshold range 101%–120% (default 110%) of line voltage. The Hi Voltage Trip delay range is 1–60 seconds (default 3 seconds). This feature may be disabled (not recommended). Verify that the mains voltage levels are not increasing to unacceptable levels during the start sequence. Verify that the mains voltage levels are not increasing to unacceptable levels during motor operation. The <i>Motor Rated Volt</i> range is 115 to 690 Vac.</p> <p>MAINS HIGH—A similar fault may occur if the mains voltage is in excess of 800 Vac. The trip threshold is not user-settable.</p>			
44	Motor Voltage Phase Reversal	Incoming line phase rotation sequence opposite of device setting. One phase missing and/or open fuse.	Set <i>Phase Sequence</i> to match incoming sequence. Verify that all circuit breakers are closed and fuses are serviceable.
<p>Notes</p> <p>Exchange two motor connection leads. If mains leads need to be changed, swap incoming leads and set <i>Phase Sequence</i> to match incoming sequence. If an upstream reverser is used, disable <i>Phase Rev Fault</i> (not recommended). This fault is not uncommon in new installations. In the event of a blown fuse prior to a START command, this fault may occur as the unit is not able to determine phase rotation with one open phase.</p>			
55	Motor Control Command Device Missing	Motor control command device was removed (DIM, Cover Control, or similar device).	Re-attach motor control command device, i.e the Digital Interface Module (DIM) and reset the fault.
<p>Notes:</p> <p>If the motor command device is to be permanently removed, purge it from the motor control command device list of the S811/S811+ (press and hold the recessed RESET button on the front of the S811 for 6 seconds minimum). The STATUS LED will change to amber when the action has started and any detached motor control devices will be purge from memory. To reinstall a DIM that has been removed, remove 24 Vdc control power, reinstall the DIM, then restore 24 Vdc control power.</p>			
56	Internal Communications	Internal communications error. Excessive internal electrical noise or hardware failure.	Try a 24 Vdc control voltage power cycle to attempt to clear problem. Verify the S811/S811+ is properly grounded. Contact EatonCare for service.
<p>Notes:</p> <p>This fault code concerns communication of devices located on the two printed circuit boards (PCBs) inside the unit. It is not affected by external communications to networks or other systems.</p>			
57	Internal Program Memory	Corrupted firmware or memory.	Cycle 24 Vdc control power to the S811/S811+. Contact EatonCare for service.
58	SCR Not Firing	SCR is not conducting when gated. Incoming phase lost. Special application—undersized or high impedance motor Load disconnected.	SCR failure. Re-apply lost phase. Review S811/S811+ application. Circuitry damaged by megger testing. Contact EatonCare for service.
<p>Notes:</p> <p>Verify that both mains and load lines are connected and secure. Verify that any isolation and/or reversing contactors are properly staged. If the load is significantly less than the frame size, not enough load may be present to allow SCRs to fire.</p>			
59	Shorted SCR	SCR is shorted. Internal bypass contactor welded shut.	Test resistance of each phase. Contact EatonCare for service.
<p>Notes:</p> <p>For the newer Trane CenTraVac application this diagnostic will cause the shunt-trip output of the S811/S811+ to activate, causing the circuit breaker or molded case switch to trip open.</p> <p>Shorted SCRs are the most common mode of SCR failure. With power completely removed from the unit, measure the resistance of each pole, line to load. If the resistance is near zero, it is most likely that the SCR is shorted. Resistance of a serviceable SCR is approximately 10k ohms.</p>			
60	SCR Over Current	Excessive SCR Current during the start ramp. Only active when Stall Fault is disabled.	Increase <i>Soft Start Time</i> and/or <i>Initial Torque</i> parameters in Soft Start Config. menu. Reduce starting load. Verify S811/S811+ is properly rated for current.
<p>Notes:</p> <p>The maximum RMS value of the three-phase currents is monitored. The SCR Over Current Trip threshold is 3X FLA and is not user-settable.</p>			
61	Mains AC Voltage Loss	Fuses or breaker open. Disconnect open.	Replace fuses, close disconnect, or reset breaker.
<p>Notes:</p> <p>The Mains Loss Fault trip threshold is 80 Vac and is not user-settable.</p>			
63	Motor Stall	Motor not at rated RPM at end of start ramp time and/or current in excess of 2X FLA. Bypass contactors not closed at the end of the start time (start current too high).	Lengthen <i>Soft Start Time</i> and/or increase <i>Initial Torque</i> in the Soft Start Config. Menu. Loads that are heavily loaded during a start such as fans will often need an initial torque setting greater than the factory default.
<p>Notes:</p> <p>At the end of the start ramp time, the motor condition is monitored for a synchronous speed condition. A Motor Stall fault will occur at the end of the ramp time if the motor is not to synchronous speed and the current is in excess of 2X FLA. This feature is not user-settable. Verify that motor is properly sized for the load.</p>			

**Table 4. S811/S811+ fault codes (continued)**

<b>Code</b>	<b>Fault</b>	<b>Condition</b>	<b>Solution</b>
64	Voltage Zero Cross Lost	Mains voltage lost. Phase L1 or L3 lost. Load disconnected.	Restore mains or lost phases. Verify that load is connected and any disconnect devices are properly staged. Contact EatonCare for service.
Notes: The SCRs are unable to fire if there is no source voltage or load on the unit. Verify that all devices are properly connected and powered prior to initiating a START command.			
*	Product Fault Control Fault	Internal PCB problems	Replace the S811/S811+.
*	LCD DIM Setup	Communications adapter connected to CH 1 with DIM installed Failure of PCB Firmware fault	Install communications adapter to correct port. Cycle 24 Vdc power to attempt to clear fault. Perform a hard reset to attempt to correct condition.
<b>Note:</b> All mains and control power connections must be completed and voltage applied prior to attempting a start. Failure to make all connections will result in one or more faults.			

## Questions

Contact the CenTraVac Technical Support Team with questions regarding this general service bulletin. To contact them, send a message to [TechService@trane.com](mailto:TechService@trane.com).

CenTraVac, Trane, and the Trane logo are trademarks or registered trademarks of Trane in the United States and other countries. All trademarks referenced in this document are the trademarks of their respective owners. Cutler-Hammer, Eaton, and EatonCare, are registered trademarks of Eaton Corporation.



Trane optimizes the performance of homes and buildings around the world. A business of Ingersoll Rand, the leader in creating and sustaining safe, comfortable and energy efficient environments, Trane offers a broad portfolio of advanced controls and HVAC systems, comprehensive building services, and parts. For more information, visit [www.Trane.com](http://www.Trane.com).

Trane has a policy of continuous product and product data improvement and reserves the right to change design and specifications without notice.

© 2012 Trane All rights reserved  
CTV-SVB49F-EN 28 Nov 2012  
Supersedes CTV-SVB49E-EN (25 Sep 2012)

