



# Operation Maintenance

# CVHE-OM-8C

Library	Service Literature
Product Section	Refrigeration
Product	Centrifugal Liquid Chillers
Model	CVHE/F/G
Literature Type	Operation/Maintenance
Sequence	8C
Date	March 1, 2001
File No.	SV-RF-CTV-CVHE-OM-8C-2001
Supersedes	SV-RF-CTV-CVHE-OM-8B-2000

## Water-Cooled Hermetic CenTraVac® MODELS CVHE, CVHF, CVHG with UCP2 Control Panel

**Design Sequence**  
CVHE "3G"  
CVHF "1T"  
CVHG "1J"

CVHE 60 HZ 230, 250, 280, 320, 360, 400, 450, 500
CVHE 50 HZ 190, 210, 240, 270, 300, 330, 370, 420
CVHF 60 HZ 350, 410, 485, 555, 640, 650, 770, 910, 1060, 1280, 1470, 1720
CVHG 50 HZ 410, 480, 565, 670, 780, 920, 1067

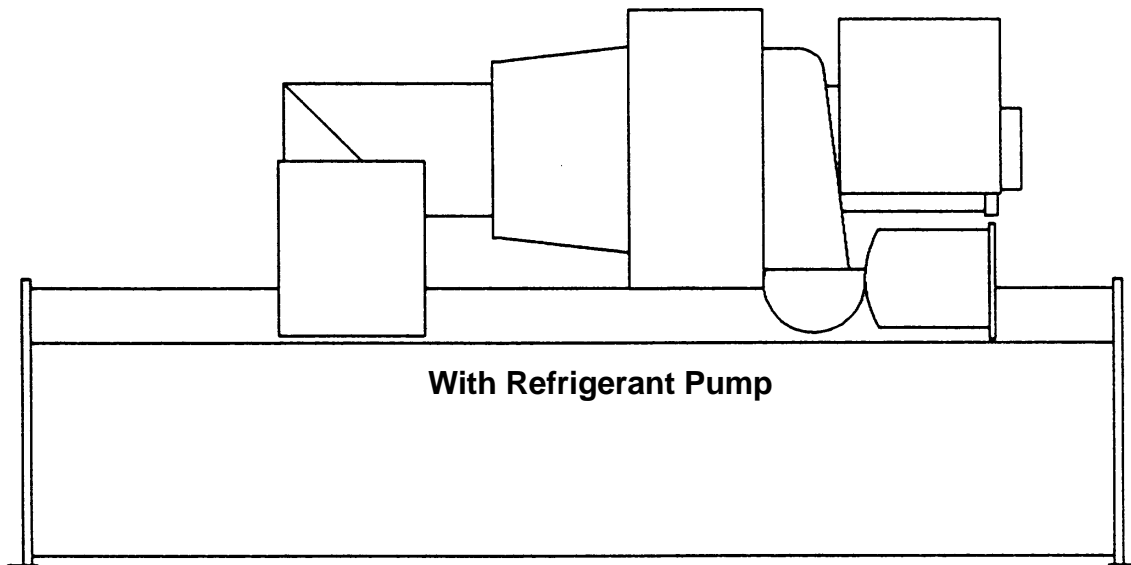

**X39640534-04**

# Warnings and Cautions

---

## NOTICE

Warnings and Cautions appear at appropriate locations throughout this manual.

Read these carefully.

**Warning:** Indicates a potentially hazardous situation which, if not avoided, could result in death or serious injury.

**CAUTION:** Indicates a potentially hazardous situation which, if not avoided, may result in minor or moderate injury. It may also be used to alert against unsafe practices and where property-damage only accidents could occur.

# Table of Contents

---

Subject	Page Number
Product Coding Definition	6
General Information	12
Literature Change	12
About this Manual	12
Commonly Used Acronyms	12
Warnings and Cautions	13
Unit Nameplate Information	13
Mechanical Operation - CVHE, CVHG	14
Overview	14
Cooling-Only Cycle	14
Units With Refrigeration Pump	18
Compressor Lubrication System - CVHE, CVHG	18
Motor Cooling System	18
Mechanical Operation - CVHF	20
Overview	20
Cooling-Only Cycle	20
CVHF Units With Refrigerant Pump	24
Compressor Lubrication System - CVHF	24
Motor Cooling System	24
Options - CVHE, CVHF, CVHG	25
Free Cooling Cycle CVHE, CVHF, CVHG	25
Heat Recovery Cycle	26
Auxiliary Condensers	26
Ice Machine Control	26
Base Loading	27
Tracer Base Loading	27
External Base Loading	27
Base Loading Control Algorithm	27
Unit Mounted Refrigerant Monitor	27
Unit Mounted Adaptive Frequency™ Drive	27
Chiller Control System	29
Unit Control Panel	29
Chiller Module (1U1)	29
Circuit Module (1U2)	31
Stepper Module (1U3)	31
Clear Language Display Module (1U4)	31
Options Module (1U5)	32
Starter Module (2U1)	32
Purge Module (3U1)	32
UCP2 Board Dip Switch Settings	43
Setup for External Current Limit Setpoint	44
Setup for External Chilled Water Setpoint	44
Refrigerant Monitor Input	44
Load Indication Output	44
Percent RLA Output	44
Percent Condenser Pressure Output	45
Refrigerant Differential Pressure Indication Output	48
Electrical Sequence of Operation	48
Overview	48

# Table of Contents

---

Subject	Page Number
Circuit Breaker 1CB1	48
Circuit Breaker 1CB2	48
Circuit Breaker 1CB3	48
Chilled and Condenser Water Flow Interlock Circuits	48
UCP2 and Wye-Delta Starter Control Circuits	48
Vane Actuator Control	49
Circuit Breaker 1CB3 Oil Pump and Refrigerant/Oil Pump	51
Restart Inhibit	51
Controls Chilled Water Reset (CWR)	54
Return Water	54
Outdoor Air Temperature	54
Where	54
Constant Return	55
Differential to Start/Stop	59
Leaving Water Temperature Cutout	59
Low Refrigerant Temperature Cutout	59
Enhanced Condenser Limit Control	59
Free Cooling	60
Hot Gas Bypass	60
Ice Machine Control	62
Unit Start-Up Procedures	62
Daily Unit Start-Up	62
Seasonal Unit Start-Up	63
Unit Shutdown Procedures	63
Daily Unit Shut-Down	63
Seasonal Unit Shut-Down	63
Trouble Analysis	64
Procedure for Selecting Current Overload Settings for UCP2	65
Periodic Maintenance	67
Overview	67
Record Keeping Forms	67
Daily Maintenance and Checks	67
Weekly Maintenance	67
Every 3 Months	67
Every 6 Months	67
Off-Season Maintenance	68
Annual Maintenance	68
Compressor Oil Change on CVHE, CVHF, CVHG	68
Oil Change Procedure	68
Replacing Oil Filter	69
Oil Filter Replacement	69
Other Maintenance Requirements	69
Lubrication	70
Refrigerant Charge	72
Recovery and Recycle Connections	73
Leak Testing	73
Cleaning the Condenser	73
Cleaning the Evaporator	74
Control Settings and Adjustments	74
Purge System	74
Installed Unit Extended Storage	75
Overview	75
Unit Preparation	75
Forms	76
"Annual Inspection Checklist and Report"	76

# Table of Contents

---

Subject	Page Number
"Checksheet and Request for Serviceman", No. 1-27.08-6 (Front and Back)	77 - 78
"Commissioning Checklist and Start-Up Test Log"	79 - 84
"Start-Up Test Log", No. 1-27.90-5 (Front and Back))	85 - 86
"CenTraVac® Adaptive Frequency Drive™ Startup and Operating Log"	87 - 89
"Trane AFDB Pre Start-Up Checklist and Service Request"	90
Figures	
Figure 1 - General CVHE and CVHG Unit Components with Refrigerant Pump	15 - 16
Figure 2 - Pressure Enthalpy Curve	17
Figure 3 - 2-Stage Economizer	17
Figure 4 - CVHE Compressor Lubrication and Motor-Cooling Systems (Units with Refrigerant Pump)	19
Figure 5 - General CVHF Components	21
Figure 6 - CVHF Pressure/Enthalpy Curve	22
Figure 7 - CVHF Economizer Operation	22
Figure 8 - CVHF Unit with Refrigerant Pump	23
Figure 9 - Base Loading with External mA Input and with External Voltage Input	28
Figure 10 - UCP2 Control Panel	29
Figure 11 - Chiller Module (1U1) - CVHE, CVHF, CVHG	30
Figure 12 - Stepper Control Module (1U3) - CVHE, CVHF, CVHG	33 - 34
Figure 13 - Clear Language Display Module (1U4) - CVHE, CVH/F, CVHG	35
Figure 14 - Options Control Module (1U5) - CVHE, CVHF, CVHG	36
Figure 15 - Purge Module (3U1) - CVHE, CVHF, CVHG	37
Figure 16 - Customer Supplied Remote Mounted Across the Line Starter	38 - 39
Figure 17 - Trane Supplied Remote Mounted Wye-Delta Starter	40 - 41
Figure 18 - Circuit Module (1U2) CVHE, CVHF, CVHG with Refrigerant Pump	42
Figure 19 - Refrigerant Monitor (4U1) - CVHE, CVHF, CVHG	47
Figure 21 - UCP2 Test/Start Timing Sequence	50
Figure 22 - CVHE, CVHF, CVHG - IGV/Actuator Operation and BPI Switch	51
Figure 23 - CVHE, CVHF, CVHG - UCP2 Restart Inhibit Timer	53
Figure 24 - Cutout Strategy	61
Figure 25 - CVHE, CVHF, CVHG - UCP Start-Run-Shutdown Sequence Timing Functions	64
Figure 26 - Rotary Valve in Drain Position	71
Figure 27 - Typical Chemical Cleaning Setup	73
Tables	
Table 1 - Recommended Length to Run Percent Condenser Pressure Output	46
Table 2 - NTON/BT Information	52
Table 3 - Values for Start Reset Types	54
Table 4 - CT-Factor X100	65
Table 5 - CT-Factor X139	66
Table 6 - CT-Factor, Current Overload Settings #1 and #2	66
Table 7 - Normal Chiller Operating Characteristics	67

# Product Coding Definition

---

The CVHE, CVHF and CVHG models are defined using the product definition and selection (PDS) system. This system describes the product offerings in terms of a product coding block which is made up of feature categories and feature codes.

The operating components and options for any Model CVHE, CVHF and CVHG CenTraVac® units can be identified by referring to the alpha-numeric product identification coding block located on the nameplate for the unit. The coding block precisely identifies all characteristics of a unit. Be sure to

refer to the service model when ordering replacements parts or requesting service. An example of a typical product code is given on this page.

**Note:** Unit-mounted starters are identified by a separate number found on the starter.

## Typical Product Description Block

MODL CVHE	DSEQ 2R	NTON 320	VOLT 575	REF 123
HRTZ 60	TYPE SNGL	CPKW 142	CPIM 222	TEST AIR
EVTM IECU	EVTH 28	EVSZ 032S	EVBS 280	
EVWC STD	EVWP 2	EVWT NMAR	EVPR 150	
EVCO VICT	EVWA LELE	CDTM IECU	CDTH 28	
CDSZ 032S	CDBS 250	CDWC STD	CDWP 2	
CDWT NMAR	CDPR 150	CDCO VICT	CDWA LELE	
CDTY STD	TSTY STD	ECTY WEOR	ORSZ 230	
PURG PURE	WCNM SNMP	SPKG DOM	OPTI CPDW	
HHOP NO	GENR NO	GNSL NO	SOPT SPSH	
ACCY ISLS	HGBP WO	LUBE SNGL	AGLT CUL	
CNIF UCP2	SRTY USTR	SRRL 207	PNCO TERM	

### MODL

#### Unit Model

CVHE = 3 stage direct drive  
CVHF = 2 stage direct drive  
CVHG = 3 stage direct drive

### DSEQ

#### Design Sequence

### EER

Energy Efficiency Rating

### EEV

Energy Efficiency Verification

### GENR

Gas Powered Chiller  
YES = Yes gas powered chiller  
NO = No gas powered chiller

### HRTZ

#### Unit Hertz

60 = 60 Hertz  
50 = 50 Hertz

### NTON

#### Nominal Tons

190 = 190 Nominal Tons  
210 = 210 Nominal Tons  
230 = 230 Nominal Tons  
240 = 240 Nominal Tons  
250 = 250 Nominal Tons

270 = 270 Nominal Tons

280 = 280 Nominal Tons

300 = 300 Nominal Tons

320 = 320 Nominal Tons

330 = 330 Nominal Tons

350 = 350 Nominal Tons

360 = 360 Nominal Tons

370 = 370 Nominal Tons

400 = 400 Nominal Tons

410 = 410 Nominal Tons

420 = 420 Nominal Tons

450 = 450 Nominal Tons

470 = 470 Nominal Tons

480 = 480 Nominal Tons

485 = 485 Nominal Tons

500 = 500 Nominal Tons

530 = 530 Nominal Tons

555 = 555 Nominal Tons

560 = 560 Nominal Tons

565 = 565 Nominal Tons

590 = 590 Nominal Tons

630 = 630 Nominal Tons

640 = 640 Nominal Tons

650 = 650 Nominal Tons

660 = 660 Nominal Tons

670 = 670 Nominal Tons

710 = 710 Nominal Tons

770 = 770 Nominal Tons

780 = 780 Nominal Tons

800 = 800 Nominal Tons

910 = 910 Nominal Tons

920 = 920 Nominal Tons

1060 = 1060 Nominal Tons

1067 = 1067 Nominal Tons

1280 = 1280 Nominal Tons

1470 = 1470 Nominal Tons

1720 = 1720 Nominal Tons

### VOLT

#### Unit Voltage

208 = 208 Volt 3 Phase

380 = 380 Volt 3 Phase

400 = 400 Volt 3 Phase

415 = 415 Volt 3 Phase

440 = 440 Volt 3 Phase

460 = 460 Volt 3 Phase

480 = 480 Volt 3 Phase

575 = 575 Volt 3 Phase

600 = 600 Volt 3 Phase

2300 = 2300 Volt 3 Phase

2400 = 2400 Volt 3 Phase

3300 = 3300 Volt 3 Phase

4160 = 4160 Volt 3 Phase

6000 = 6000 Volt 3 Phase

6600 = 6600 Volt 3 Phase

# Product Coding Definition

---

## CPKW

### Compressor Motor Power

142 = 142 KW compressor motor 60hz  
154 = 154 KW com pressor motor 60hz  
171 = 171 KW compressor motor 60hz  
187 = 187 KW compressor motor 60hz  
204 = 204 KW compressor motor 60hz  
231 = 231 KW compressor motor 60hz  
257 = 257 KW compressor motor 60hz  
287 = 287 KW compressor motor 60hz  
323 = 323 KW compressor motor 60hz  
361 = 361 KW compressor motor 60hz  
403 = 403 KW compressor motor 60hz  
453 = 453 KW compressor motor 60hz  
512 = 512 KW compressor motor 60hz  
588 = 588 KW compressor motor 60hz  
653 = 653 KW compressor motor 60hz  
745 = 745 KW compressor motor 60hz  
856 = 856 KW compressor motor 60hz  
957 = 957 KW compressor motor 60hz  
1062 = 1062 KW compressor motor 60hz  
1228 = 1228 KW compressor motor 60hz  
1340 = 1340 KW compressor motor 60hz  
143 = 143 KW compressor motor 50hz  
156 = 156 KW compressor motor 50hz  
170 = 170 KW compressor motor 50hz  
193 = 193 KW compressor motor 50hz  
215 = 215 KW compressor motor 50hz  
242 = 242 KW compressor motor 50hz  
270 = 270 KW compressor motor 50hz  
301 = 301 KW compressor motor 50hz  
337 = 337 KW compressor motor 50hz  
379 = 379 KW compressor motor 50hz  
433 = 433 KW compressor motor 50hz  
489 = 489 KW compressor motor 50hz  
548 = 548 KW compressor motor 50hz  
621 = 621 KW compressor motor 50hz  
716 = 716 KW compressor motor 50hz  
799 = 799 KW compressor motor 50hz  
892 = 892 KW compressor motor 50hz

## CPIM

### Compressor Impeller Diameter

210 = 210 Impeller Cutback  
212 = 212 Impeller Cutback  
213 = 213 Impeller Cutback  
215 = 215 Impeller Cutback  
217 = 217 Impeller Cutback  
218 = 218 Impeller Cutback  
220 = 220 Impeller Cutback  
222 = 222 Impeller Cutback  
223 = 223 Impeller Cutback  
225 = 225 Impeller Cutback  
227 = 227 Impeller Cutback  
228 = 228 Impeller Cutback  
230 = 230 Impeller Cutback  
232 = 232 Impeller Cutback  
233 = 233 Impeller Cutback  
235 = 235 Impeller Cutback  
237 = 237 Impeller Cutback  
238 = 238 Impeller Cutback  
240 = 240 Impeller Cutback  
242 = 242 Impeller Cutback  
243 = 243 Impeller Cutback  
245 = 245 Impeller Cutback  
247 = 247 Impeller Cutback  
248 = 248 Impeller Cutback  
250 = 250 Impeller Cutback  
252 = 252 Impeller Cutback  
253 = 253 Impeller Cutback  
255 = 255 Impeller Cutback  
256 = 256 Impeller Cutback  
257 = 250 Impeller Cutback  
258 = 258 Impeller Cutback  
259 = 259 Impeller Cutback  
260 = 260 Impeller Cutback  
261 = 261 Impeller Cutback  
262 = 262 Impeller Cutback  
263 = 263 Impeller Cutback  
264 = 264 Impeller Cutback  
265 = 265 Impeller Cutback  
266 = 266 Impeller Cutback  
267 = 267 Impeller Cutback  
268 = 268 Impeller Cutback  
269 = 269 Impeller Cutback  
270 = 270 Impeller Cutback  
271 = 271 Impeller Cutback  
272 = 272 Impeller Cutback  
273 = 273 Impeller Cutback  
274 = 274 Impeller Cutback  
275 = 275 Impeller Cutback  
276 = 276 Impeller Cutback  
277 = 277 Impeller Cutback  
278 = 278 Impeller Cutback  
279 = 279 Impeller Cutback  
280 = 280 Impeller Cutback  
281 = 281 Impeller Cutback  
282 = 282 Impeller Cutback  
283 = 283 Impeller Cutback  
284 = 284 Impeller Cutback  
285 = 285 Impeller Cutback  
286 = 286 Impeller Cutback  
287 = 287 Impeller Cutback  
288 = 288 Impeller Cutback  
289 = 289 Impeller Cutback  
290 = 290 Impeller Cutback  
291 = 291 Impeller Cutback  
292 = 292 Impeller Cutback  
293 = 293 Impeller Cutback  
294 = 294 Impeller Cutback  
295 = 295 Impeller Cutback

# Product Coding Definition

---

## CPIM

### Compressor Impeller Diameter

296 = 296 Impeller Cutback  
297 = 297 Impeller Cutback  
298 = 298 Impeller Cutback  
299 = 299 Impeller Cutback  
300 = 300 Impeller Cutback  
301 = 301 Impeller Cutback  
302 = 302 Impeller Cutback  
303 = 303 Impeller Cutback  
223 = 223 Impeller Cutback  
304 = 304 Impeller Cutback  
305 = 305 Impeller Cutback  
306 = 306 Impeller Cutback  
307 = 307 Impeller Cutback  
308 = 308 Impeller Cutback  
309 = 309 Impeller Cutback  
310 = 310 Impeller Cutback  
311 = 311 Impeller Cutback  
312 = 312 Impeller Cutback  
313 = 313 Impeller Cutback  
314 = 314 Impeller Cutback  
315 = 315 Impeller Cutback  
316 = 316 Impeller Cutback  
317 = 317 Impeller Cutback  
318 = 318 Impeller Cutback  
319 = 319 Impeller Cutback  
320 = 320 Impeller Cutback  
321 = 321 Impeller Cutback  
322 = 322 Impeller Cutback  
323 = 323 Impeller Cutback  
324 = 324 Impeller Cutback  
325 = 325 Impeller Cutback  
326 = 326 Impeller Cutback  
327 = 327 Impeller Cutback  
328 = 328 Impeller Cutback  
329 = 329 Impeller Cutback  
330 = 330 Impeller Cutback  
331 = 331 Impeller Cutback  
332 = 332 Impeller Cutback  
333 = 333 Impeller Cutback  
334 = 334 Impeller Cutback  
335 = 335 Impeller Cutback

### Type

#### Unit Type

AUX = Auxiliary Condenser  
HTRC = Heat Recovery  
SNGL = Single Condenser Cooling Only

## ECTY

### Economizer Type

WEOR = 2 Stage Economizer

## EVSZ

### Evaporator Size

032S = 320 Ton Short Shell  
032L = 320 Ton Long Shell  
050S = 500 Ton Short Shell  
050L = 500 Ton Long Shell  
080S = 800 Ton Short Shell  
080L = 800 Ton Long Shell  
142M = 1420 Ton Medium Shell  
142L = 1420 Ton Long Shell  
142E = 1420 Ton Extended Shell  
210L = 2100 Ton Long Shell  
250E = 2500 Ton Extended Shell

## EVBS

### Evaporator Tube Bundle Size

200 = 200 Nominal Ton Evap  
230 = 230 Nominal Ton Evap  
250 = 250 Nominal Ton Evap  
280 = 280 Nominal Ton Evap  
320 = 320 Nominal Ton Evap  
350 = 350 Nominal Ton Evap  
360 = 360 Nominal Ton Evap  
400 = 400 Nominal Ton Evap  
450 = 450 Nominal Ton Evap  
500 = 500 Nominal Ton Evap  
560 = 560 Nominal Ton Evap  
630 = 630 Nominal Ton Evap  
710 = 710 Nominal Ton Evap  
800 = 800 Nominal Ton Evap  
890 = 890 Nominal Ton Evap  
1080 = 1080 Nominal Ton Evap  
1220 = 1220 Nominal Ton Evap  
1420 = 1420 Nominal Ton Evap  
1610 = 1610 Nominal Ton Evap  
1760 = 1760 Nominal Ton Evap  
1900 = 1900 Nominal Ton Evap  
2100 = 2100 Nominal Ton Evap  
2300 = 2300 Nominal Ton Evap  
2500 = 2500 Nominal Ton Evap

## EVTM

### Evaporator Tubes

IECU = 1.0" Internally Enhanced CU Tubing  
TECU = 3/4" Internally Enhanced CU Tubing  
SBCU = 3/4" Smooth Bore CU Tubing

## EVTH

### Evaporator Fluid Type

WATE = Water  
CACL = Calcium Chloride  
EG = Ethylene Glycol  
PG = Propylene Glycol

## EVWT

### Evaporator Waterbox Type

NMAR = Nonmarine  
MAR = Marine

## EVWP

### Evaporator Water Pass

1 = 1 Pass Evaporator  
2 = 2 Pass Evaporator  
3 = 3 Pass Evaporator

## EVWC

### Evaporator Waterbox Construction

STD = Standard Construction

## EVPR

### Evaporator Waterbox Pressure

150 = 150 PSIG  
300 = 300 PSIG

## EVCO

### Evaporator Waterbox Connection

Vict = Victaulic Connection  
FLNG = Flanged Connection

# Product Coding Definition

---

## EVWA

### Evap Waterbox Arrangement

RERE = Inlet - RH End  
RERE = Outlet - RH End

RELE = Inlet - RH End  
RELE = Outlet - LH End

LELE = Inlet - LH End  
LELE = Outlet - LH End

LERE = Inlet - LH End  
LERE = Outlet - RH End

END = In one end out the other

LFLR = Inlet - LH Front  
LFLR = Outlet - LH Rear

LRLF = Inlet - LH Rear  
LRLF = Outlet - LH Front

RFRR = Inlet - RH Front  
RFRR = Outlet - RH Rear

RRRF = Inlet - RH Rear  
RRRF = Outlet - RH Front

FRONT = In Front Out Front

REAR = In Rear Out Rear

LFRR = Inlet - LH Front  
LFRR = Outlet - RH Rear

RRLF = Inlet - RH Rear  
RRLF = Outlet - LH Front

LRRF = Inlet - LH Rear  
LRRF = Outlet - RH Front

RFLR = Inlet - RH Front  
RFLR = Outlet - LH Rear

## CDSZ

### Condenser Size

032S = 320 Ton Short Shell  
032L = 320 Ton Long Shell  
050S = 500 Ton Short Shell  
050L = 500 Ton Long Shell  
080S = 800 Ton Short Shell  
080L = 800 Ton Long Shell  
142L = 1420 Ton Long Shell  
210L = 2100 Ton Long Shell  
250L = 2500 Ton Long Shell

## CDBS

### Condenser Tube Bundle Size

230 = 230 Nominal Ton Cond  
250 = 250 Nominal Ton Cond  
280 = 280 Nominal Ton Cond  
320 = 320 Nominal Ton Cond  
360 = 360 Nominal Ton Cond  
400 = 400 Nominal Ton Cond  
450 = 450 Nominal Ton Cond  
500 = 500 Nominal Ton Cond  
560 = 560 Nominal Ton Cond  
630 = 630 Nominal Ton Cond  
710 = 710 Nominal Ton Cond  
800 = 800 Nominal Ton Cond  
890 = 890 Nominal Ton Cond

## CDBS

### Condenser Tube Size

980 = 980 Nominal Ton Cond  
1080 = 1080 Nominal Ton Cond  
1220 = 1220 Nominal Ton Cond  
1420 = 1420 Nominal Ton Cond

1610 = 1610 Nominal Ton Cond  
1760 = 1760 Nominal Ton Cond  
1900 = 1900 Nominal Ton Cond  
2100 = 2100 Nominal Ton Cond  
2300 = 2300 Nominal Ton Cond  
2500 = 2500 Nominal Ton Cond

## CDTM

### Condenser Tube Material

IECU = 1.0" Internally Enhanced CU Tube  
TECU = 3/4" Internally Enhanced CU Tube  
SBCU = 3/4" Smooth Bore CU Tube  
SB91 = 3/4" Smooth Bore 90/10 CU/NI Tube

## CDTH

### Condenser Tube Thickness

28 = .028" Wall Thickness  
35 = .035" Wall Thickness

## CFLC

### Condenser Fluid Type

WATE - Fluid Type = Water  
CACL - Fluid Type = Calcium Chloride  
EG - Fluid Type = Ethylene Glycol  
PG - Fluid Type = Propylene Glycol

## CDTY

### Condenser Shell Construction

STD = Standard Condenser Construction  
ASME = ASME Condenser Construction

## CDWT

### Condenser Waterbox Type

NMAR = Nonmarine  
MAR = Marine

## CDWC

### Condenser Waterbox Weld Type

STD = Standard Waterbox  
ASME = ASME Waterbox

## CDPR

### Condenser Water Side Pressure

150 = 150 PSIG  
300 = 300 PSIG

## CDWP

### Condenser Water Pass

2 = 2 Pass  
3 = 3 Pass

## CDCO

### Condenser Waterbox Connection

VICT = Victaulic Connection  
FLNG = Flanged Connection

## CDWA

### Cond Waterbox Arrangement

RERE = In RH End - Out RH End  
LELE = In LH End - Out LH End  
LFLF = In LH Fron - Out LH Front  
LRLR = In LH Rear - Out LH Rear  
RFRR = In RH Front - Out RH Front  
RRRR = In RH Rear - Out RH Rear  
RRRF = In RH Rear - Out RH Front  
RRRF = IN RH Rear - Out RH Front

## TSTY

### Tube Sheet Construction

STD = Standard  
ASME = ASME

## ORSZ

### Orifice Size

180 = 180 Nominal Ton Orifice  
200 = 200 Nominal Ton Orifice  
210 = 210 Nominal Ton Orifice  
230 = 230 Nominal Ton Orifice  
240 = 240 Nominal Ton Orifice  
250 = 250 Nominal Ton Orifice  
265 = 265 Nominal Ton Orifice  
280 = 280 Nominal Ton Orifice  
300 = 300 Nominal Ton Orifice  
320 = 320 Nominal Ton Orifice  
340 = 340 Nominal Ton Orifice  
360 = 360 Nominal Ton Orifice  
375 = 375 Nominal Ton Orifice  
400 = 400 Nominal Ton Orifice  
415 = 415 Nominal Ton Orifice  
450 = 450 Nominal Ton Orifice  
460 = 460 Nominal Ton Orifice  
500 = 500 Nominal Ton Orifice  
510 = 510 Nominal Ton Orifice  
560 = 560 Nominal Ton Orifice  
585 = 585 Nominal Ton Orifice  
630 = 630 Nominal Ton Orifice  
650 = 650 Nominal Ton Orifice  
680 = 680 Nominal Ton Orifice  
710 = 710 Nominal Ton Orifice  
750 = 750 Nominal Ton Orifice  
790 = 790 Nominal Ton Orifice  
800 = 800 Nominal Ton Orifice  
835 = 835 Nominal Ton Orifice  
880 = 880 Nominal Ton Orifice  
900 = 900 Nominal Ton Orifice  
935 = 935 Nominal Ton Orifice  
990 = 990 Nominal Ton Orifice  
1000 = 1000 Nominal Ton Orifice  
1045 = 1045 Nominal Ton Orifice  
1100 = 1100 Nominal Ton Orifice  
1120 = 1120 Nominal Ton Orifice  
1185 = 1185 Nominal Ton Orifice  
1250 = 1250 Nominal Ton Orifice  
1265 = 1265 Nominal Ton Orifice  
1335 = 1335 Nominal Ton Orifice  
1400 = 1400 Nominal Ton Orifice  
1475 = 1475 Nominal Ton Orifice  
1540 = 1540 Nominal Ton Orifice  
1600 = 1600 Nominal Ton Orifice  
1605 = 1605 Nominal Ton Orifice  
1660 = 1660 Nominal Ton Orifice  
1735 = 1735 Nominal Ton Orifice  
1800 = 1800 Nominal Ton Orifice  
1810 = 1810 Nominal Ton Orifice  
1890 = 1890 Nominal Ton Orifice  
1970 = 1970 Nominal Ton Orifice  
2060 = 2060 Nominal Ton Orifice  
2150 = 2150 Nominal Ton Orifice  
2245 = 2245 Nominal Ton Orifice  
2345 = 2245 Nominal Ton Orifice  
2450 = 2450 Nominal Ton Orifice

# Product Coding Definition

## AGLT

### Agency Listing

None = No Agency Listing  
UL = U.L. Listed  
CUL = UL Listed with EEV  
CLCA = Calif. Code (Includes U.L List)

## HGBP

### Hot Gas Bypass

With = Hotgas By pass  
WO = Without Hotgas Bypass

## OPTI

### Unit Options

AAZ = International Package  
CPDW = Compressor Doweling Only  
FRCL = Free Cooling  
INSL = Unit Insulation  
JAGA = Control Panel Gauges for Japan,  
SSCD = Separable Shell/cmpr. Dowling  
SPSH = Separable Shells with Compressor  
Doweling

## LUBE

SNGL = Single Oil Filter

## PURG

### Purge Unit

PURG = Purifier Purge

## CNIF

### Control Interface

UCP2 = Micro Processor 2nd Generation

## COPT

### Control Options for UCP2

ACOS = Water Temperature Sensor  
ARMN = Refrg Monitor without Scanner  
ARMS = Refrg Monitor with Scanner  
BRTS = Bearing Oil Temperature Sensors  
CLCT = Condenser Limit Controls  
CLDC = Complex Character CLD  
CWR = Chilled Water Reset Ambient  
DIST = Discharge Temperature Sensor  
MONP = Monitoring Package  
OPTM = Options Module  
PNCH = Printer Interface Module  
TRMI = Tracer 100 Interface Module  
TRMM = Tracer Interface Control Module  
TRMS = Tracer Summit Interface Module  
WFCH = Water Pressure Sensors. 150 PSI  
WFCL = Water Pressure Sensors <150 PSI  
WPSR = Chilled/tower Water Flow Display  
WVUO = Under-Over Voltage Protection

## AMOP

### Air Monitor Options

AAKT = Audible Alarm Kit  
AA1L = Audible Alarm Kit with 1 Light  
AA3L = Audible Alarm Kit with 3 Lights  
4CSK = 4-Channel Scanner Kit

## ACCY

### Unit Accessory

2FS1 = 2 Flow Switches 150 PSI NEMA 1  
2FS2 = 2 Flow Switches 300 PSI NEMA 1  
2FS3 = 2 Flow Switch 150 PSI Vapor  
2FS4 = 2 Flow Switch 300 PSI Vapor  
2TME = 2 Thermometers 10" Extd Well  
2TMS = 2 Thermometers 10" Std Well

2TR5 = 2 TR5 Timers  
3FS1 = 3 Flow Switches 150 PSI NEMA 1  
3FS2 = 3 Flow Switches 300 PSI NEMA 1  
3FS3 = 3 Flow Switch 150 PSI Vapor  
3FS4 = 3 Flow Switch 300 PSI Vapor  
3TME = 3 Thermometers 10" Extd Well  
3TR5 = 3 TR5 Timers  
FS1 = 1 Flow Switch 150 PSI NEMA 1  
FS2 = 1 Flow Switch 300 PSI NEMA 1  
FS3 = 1 Flow Switch 150 PSI Vapor  
FS4 = 1 Flow Switch 300 PSI Vapor  
ISLS = Spring Isolators  
TME = 1 Thermometer 10" EvtD Well  
TMS = 1 Thermometer 10" Std Well  
TR5 = 1 TR5 Timer

## MODL

### Starter Model

CVSF = Centrifugal Chiller Starter

## SRTY

### Starter Type

UAFD = Unit Mounted AFD  
USRT = Star-Delta  
USID = Solid-State Unit Mounted  
USOL = Solid-State  
RSTR = Star-Delta  
RSOL = Solid State  
RXL = X-Line Full Volt  
RATR = Autotransformer  
RPIR = Primary Reactor  
CSTR = Star-Delta  
CSOL = Solid State  
CXL = X-Line Full Volt  
CATR - Autotransformer  
CPIR = Primary Reactor

## VOLT

### Starter Voltage

208 = 208 Volt 60 Hz 3 Phase  
208 = 230 Volt 60 Hz 3 Phase  
380 = 380 Volt 60 Hz 3 Phase  
440 = 440 Volt 60 Hz 3 Phase  
460 = 460 Volt 60 Hz 3 Phase  
480 = 480 Volt 60 Hz 3 Phase  
575 = 575 Volt 60 Hz 3 Phase  
600 = 600 Volt 60 Hz 3 Phase  
2300 = 2300 Volt 60 Hz 3 Phase  
2400 = 2400 Volt 60 Hz 3 Phase  
4160 = 4160 Volt 60 Hz 3 Phase  
3300 = 3300 Volt 60 Hz 3 Phase  
6600 = 6600 Volt 60 Hz 3 Phase

380A = 380 Volt 50 HZ 3 Phase  
400 = 400 Volt 50 HZ 3 Phase  
415 = 415 Volt 50 HZ 3 Phase  
330A = 3300 Volt 50 HZ 3 Phase  
6000 = 6000 Volt 50 Hz 3 Phase  
660A = 6600 Volt 50 Hz 3 Phase

## SRRL

### Starter Size Based on Max RLA

94 = 94 Maximum Starter RLA  
155 = 155 Maximum Starter RLA  
187 = 187 Maximum Starter RLA  
200 = 200 Maximum Starter RLA  
207 = 207 Maximum Starter RLA  
233 = 233 Maximum Starter RLA  
346 = 346 Maximum Starter RLA  
360 = 360 Maximum Starter RLA  
372 = 372 Maximum Starter RLA  
467 = 467 Maximum Starter RLA  
553 = 553 Maximum Starter RLA  
592 = 592 Maximum Starter RLA  
606 = 606 Maximum Starter RLA

606 = 606 Maximum Starter RLA  
700 = 700 Maximum Starter RLA  
935 = 935 Maximum Starter RLA  
1080 = 1080 Maximum RLA  
1212 = 1212 Maximum Starter RLA  
1402 = 1402 Maximum Starter RLA  
1856 = 1856 Maximum Starter RLA

## PNCO

### Connection Type

CB = Circuit Breaker  
CBCL = Circuit Breaker Current Limiting  
CBHC = Circuit Breaker Higher-Interrupt  
CBIC = Circuit Breaker High-Interrupt  
DISC = Non-fused Disconnect Switch  
ISSW = Isolation Switch  
TERM = Terminal Block Connection

## AGLS

### Agency Listing

None = No Agency Listing  
UL = U.L. Listed  
CUL = UL Listed with EER  
CLCA = California Code (Includes U.L.  
Listing

## SRFC

### Power Factor Correct Capacitor

YES = PFCC Correct to 93.5 - 95.5% PF

## SRLT

### Surge Protector/Lightning Arrestor

YES = Surge protector/Lightning Arrestor

## UNVR

### Under/Over Voltage Relay

YES = Under/Over Voltage Relay

## GRDF

### Ground Fault Protection

YES = Ground Fault Protection

## SRMT

### Control Meters

CTRB = Volt & Amp Meters  
CTRV = Volt Meters  
CTRA = Amp Meters

## MODL

### Adaptive Frequency Drive

AFDB = Adaptive Frequency Drive

## SRRL

### Frequency Drive Frame Size

386 = Frame Size - 386 Max RLA  
500 = Frame Size - 500 Max RLA  
643 = Frame Size - 643 Max RLA

## FSUP

### Factory Startup

LM = 50 Miles or Less  
HM = 51 Miles or More

## HRIN

### Harmonic Attenuation

LNRC = Remote Mounted Line Reactor  
UNLR = Unit Mounted Line Reactor  
S12 = 12 Pulse Auto Transformer

# Product Coding Definition

---

## CHSZ

### Heat Recovery Condenser Shell Size

032S = 320 Ton Short Shell  
032L = 320 Ton Long Shell  
050S = 500 Ton Short Shell  
050L = 500 Ton Long Shell  
080S = 800 Ton Short Shell  
080L = 800 Ton Long Shell  
142L = 1420 Ton Long Shell  
210L = 2100 Ton Long Shell

## CHBS

### Condenser Tube Bundle Size

230 = 230 Nominal Tons  
250 = 250 Nominal Tons  
280 = 280 Nominal Tons  
320 = 320 Nominal Tons  
400 = 400 Nominal Tons  
450 = 450 Nominal Tons  
500 = 500 Nominal Tons  
560 = 560 Nominal Tons  
630 = 630 Nominal Tons  
710 = 710 Nominal Tons  
800 = 800 Nominal Tons  
890 = 890 Nominal Tons  
980 = 980 Nominal Tons  
1080 = 1080 Nominal Tons  
1220 = 1220 Nominal Tons  
1420 = 1420 Nominal Tons  
1610 = 1610 Nominal Tons  
1760 = 1760 Nominal Tons  
1900 = 1900 Nominal Tons  
2100 = 2100 Nominal Tons

## CHTM

### Condenser Tube Material

IECU = 1.0" Internally Enhanced Cu Tube  
TECU = 0.75" Internally Enhanced CU Tube  
SBCU = 0.75" Smooth Bore CU Tube  
SB91 = 0.75" Smooth Bore 90/10 CU/NI Tube  
SBTI = 0.75" Smooth Bore Titanium  
SB73 = 0.75" Smooth Bore 70/30 CU/NI Tube

## CHTH

### Condenser Tube Wall Thickness

28 = .028" Tube Wall Thickness  
35 = .035" Tube Wall Thickness  
25 = .025" Tube Wall Thickness  
42 = .042" Tube Wall Thickness  
49 = .049" Tube Wall Thickness

## HFLD

### Condenser Fluid Type

WATE = Fluid Type - Water  
CACL = Fluid Type - Calcium Chloride  
EG = Fluid Type - Ethylene Glycol  
PG = Fluid Type - Propylene Glycol

## CHWC

### Condenser Waterbox Construction

STD = Standard Waterbox Construction  
ASME = ASME Waterbox Construction

## CHWT

### Condenser Waterbox Type

NMAR = Non-marine Waterbox  
MAR = Marine Waterbox

## CHPR

### Condenser Waterbox Pressure

150 = 150 PSIG Water Pressure  
300 = 300 PSIG Water Pressure

## CHCO

### Condenser Waterbox Connection

VICT = Victaulic Connection  
FLNG = Flanged Connection

## CHWA

### Condenser Waterbox Arrangement

RERE = In RH End - Out RH End  
LERE = In LH End - Out LH End  
LFLF = In LH Front - Out LH Front  
LRLR = In LH Rear - Out LH Rear  
RFRF = In RH Front - Out RH Front  
RRRR = In RH Rear - Out RH Rear  
LFLR = In LH Front - Out LH Rear  
LRLF = In LH Rear - Out LH Front  
RFRR = In RH Front - Out RH Rear  
RRRF = In RH Rear - Out RH Front

## CABS

### Condenser Bundle Size

80 = 80 Nominal Tons  
130 = 130 Nominal Tons

## CATM

### Condenser Tube Material

IECU = 1.0" Internally Enhanced Cu Tube  
TECU = 0.75" Internally Enhanced CU Tube  
SBCU = 0.75" Smooth Bore CU Tube  
SB91 = 0.75" Smooth Bore 90/10 CU/NI Tube  
SB73 = 0.75" Smooth Bore 70/30 CU/NI Tube  
SBTI = 0.75" Smooth Bore Titanium

## CATH

### Condenser Tube Wall Thickness

28 = .028" Tube Wall Thickness  
35 = .035" Tube Wall Thickness  
42 = .042" Tube Wall Thickness

## HFLD

### Condenser Fluid Type

WATE = Fluid Type - Water  
CACL = Fluid Type - Calcium Chloride  
EG = Fluid Type - Ethylene Glycol  
PG = Fluid Type - Propylene Glycol

## CAWT

### Condenser Waterbox Type

NMAR = Non-marine Waterbox  
MAR = Marine Waterbox

## CAPR

### Condenser Water Side Pressure

150 = 150 PSIG Water Pressure  
300 = 300 PSIG Water Pressure

## CACO

### Condenser Waterbox Connection

VICT = Victaulic Connection  
FLNG = Flanged Connection

## CAWA

### Condenser Waterbox Arrangement

RERE = In RH End - Out RH End  
LELE = In LH End - Out LH End  
LFLF = In LH Front - Out LH Front  
LRLR = In LH Rear - Out LH Rear  
RFRF = In RH Front - Out RH Front  
RRRR = In RH Rear - Out RH Rear  
LFLR = In LH Front - Out LH Rear  
LRLF = In LH Rear - Out LH Front  
RFRR = In RH Front - Out RH Rear  
RRRF = In RH Rear - Out RH Front

# General Information

---

## Literature Change

CVHE-OM-8C - March 2001

Supersedes:

CVHE-OM-8B - September 2000

CVHE-OM-8A - December 1999

CVHE-OM-8 - May 1999

## About this manual

Information regarding 032 and 050 shell sizes on models CVHE, CVHF and CVHG is in this manual.

Extended capacity, available only on models CVHF 1470 and 1720, has been added to this manual.

The operation and maintenance of 50 and 60 Hz. CVHE, CVHF and CVHG centrifugal chillers equipped with micro-computer-based control systems, whether standard cooling or heat recovery, is described.

**Important:** *All diagnostic information is provided in the latest revision of the clear language display manual, CVHE-CLD-1A or latest revision which ships with the unit or is available at the nearest trane office.*

By carefully reviewing this information and following the instructions given, the owner/operator can successfully operate and maintain a CVHE, CVHF or CVHG unit.

If mechanical problems do occur, however, contact a qualified service organization to ensure proper diagnosis and repair of the unit.

## Commonly Used Acronyms

For convenience, a number of acronyms are used throughout this manual. These acronyms are listed alphabetically below, along with the "translation" of each:

For your convenience, a number of acronyms are used throughout this manual. These acronyms are listed alphabetically below, along with the "translation" of each:

AFDB = Adaptive Frequency Drive

ASME = American Society of Mechanical Engineers

ASHRAE = American Society of Heating, Refrigerating and Air Conditioning Engineers

BAS = Building Automation System

CABS = Auxiliary Condenser Tube-Bundle S

CDBS = Condenser Bundle Size

CDSZ = Condenser Shell Size

CLD = Clear Language Display

CWR = Chilled Water Reset

DFTL = Design Delta-T at Full Load (i.e., the difference between entering and leaving chilled water temperatures)

ENT = Entering Chilled Water Temperature

FC = Free Cooling

GPM = Gallons-per-minute

HGBP = Hot Gas Bypass

HVAC = Heating, Ventilating, and Air Conditioning

IE = Internally-Enhanced Tubes

IPC = Interprocessor Communication

LBU = La Crosse Business Unit

LCD = Liquid Crystal Display

LED = Light Emitting Diode

PFCC = Power Factor Correction Capacitor

LCD = Liquid Crystal Display

LED = Light Emitting Diode

PFCC = Power Factor Correction Capacitor

PSID = Pounds-per-Square-Inch (differential pressure)

PSIG = Pounds-per-Square-Inch (gauge pressure)

RCLD = Remote Clear Language Display

UCP2 = Chiller Control Panel for CenTraVacs

# General Information

---

## Warnings and Cautions

Notice that warnings and cautions appear at appropriate intervals throughout this manual. Warnings are provided to alert installing contractors to potential hazards that could result in personal injury or death, while cautions are designed to alert personnel to conditions that could result in equipment damage.

Your personal safety and the proper operation of this machine depend upon the strict observance of these precautions.

## Unit Nameplate Information

**The unit nameplate is located on the left side of the unit control panel (UCP).** The following information is provided on the unit nameplate.

1. Service model and size descriptor
2. Unit serial number
3. Identifies unit electrical requirements
4. Correct operating charges and type of refrigerant
5. Unit Test Pressures and Maximum Operating Pressures
6. Identifies unit Installation and Operation and Maintenance manuals
7. Product Description Block (Identifies all unit components and unit "design sequence" used to order literature and make other inquiries about the unit).
8. Drawing numbers for Unit Wiring Diagrams.

# Mechanical Operation - CVHE, CVHG

---

## Overview

THE FOLLOWING INFORMATION APPLIES TO THE TRANE MODEL CVHE AND CVHG CENTRIFUGAL CHILLER ONLY. CVHF INFORMATION IS DISCUSSED IN ANOTHER SECTION OF THIS MANUAL. Refer to the appropriate operation manual for refrigeration cycle descriptions of other models.

Each CVHE, CVHG unit is composed of 5 basic components.

- the evaporator,
- 3-stage compressor,
- water-cooled condenser,
- 2-stage economizer,
- related interconnecting piping.

A heat-recovery or auxiliary condenser can be factory-added to the basic unit assembly to provide a heat-recovery cycle.

**Figure 1 illustrates the general component layout of a typical CVHE, CVHG chiller.**

CVHE, CVHG cooling-only and heat recovery modes of operation are described in the following sections. A pressure enthalpy diagram (shown in Figure 2) is provided to further illustrate unit operation.

## Cooling-Only Cycle

When the CVHE or CVHG is functioning in the cooling mode, liquid refrigerant is distributed along the length of the evaporator and sprayed through small holes in a distributor (i.e., running the entire length of the shell) to uniformly coat each evaporator tube. Here, the liquid refrigerant absorbs enough heat from the system water circulating through the evaporator tubes to vaporize.

The gaseous refrigerant is then drawn through the eliminators (which remove droplets of liquid refrigerant from the gas) and first-stage variable inlet guide vanes, and into the first stage impeller.

**Note:** Inlet guide vanes are designed to modulate the flow of gaseous refrigerant to meet system capacity requirements; they also prorate the gas, allowing it to enter the impeller at an optimal angle that maximizes efficiency at all load conditions.

Compressed gas from the first-stage impeller flows through the fixed, second-stage inlet vanes and into the second-stage impeller.

Here, the refrigerant gas is again compressed, and then discharged through the third-stage variable guide vanes and into the third-stage impeller.

Once the gas is compressed a third time, it is discharged into the condenser. Baffles within the condenser shell distribute the compressed refrigerant gas evenly across the condenser tube bundle. Cooling tower water circulated through the condenser tubes absorbs heat from the refrigerant, causing it to condense. The liquid refrigerant then passes through orifice plate "A" and into the economizer.

The economizer reduces the energy requirements of the refrigerant cycle by eliminating the need to pass all gaseous refrigerant through three stages of compression. See Figure 3. Notice that some of the liquid refrigerant flashes to a gas because of the pressure drop created by the orifice plates, thus further cooling the liquid refrigerant. This flash gas is then drawn directly from the first (Chamber A) and second (Chamber B) stages of the economizer into the third- and second-stage impellers of the compressor, respectively.

All remaining liquid refrigerant flows through another orifice plate "C" to the evaporator.

# Mechanical Operation - CVHE, CVHG

---

Figure 1 -  
General CVHE and CVHG Unit Components (next page)

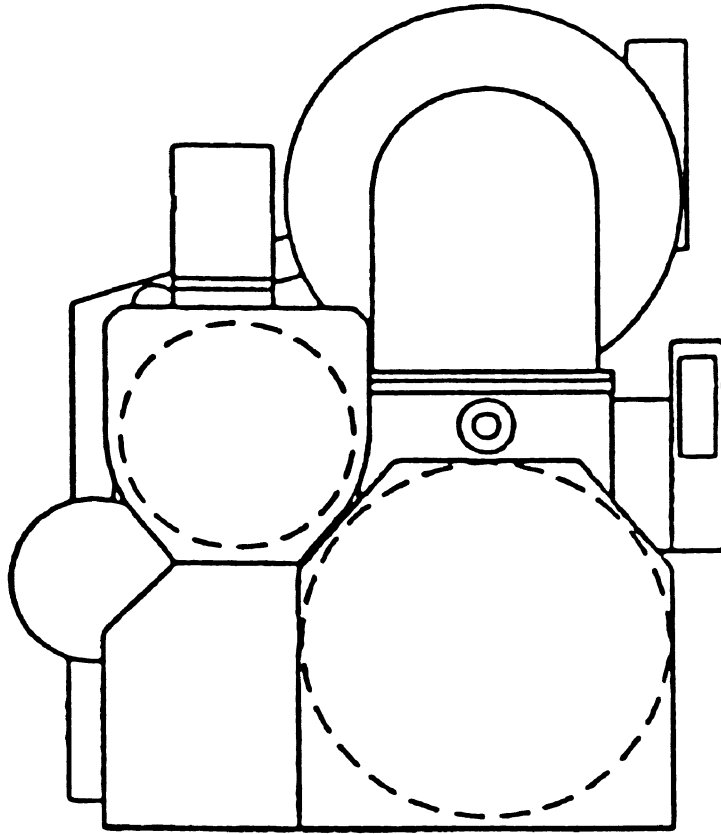

# Mechanical Operation - CVHE, CVHG

Figure 1 - (Continued)  
General CVHE and CVHG Unit Components with Refrigerant Pump

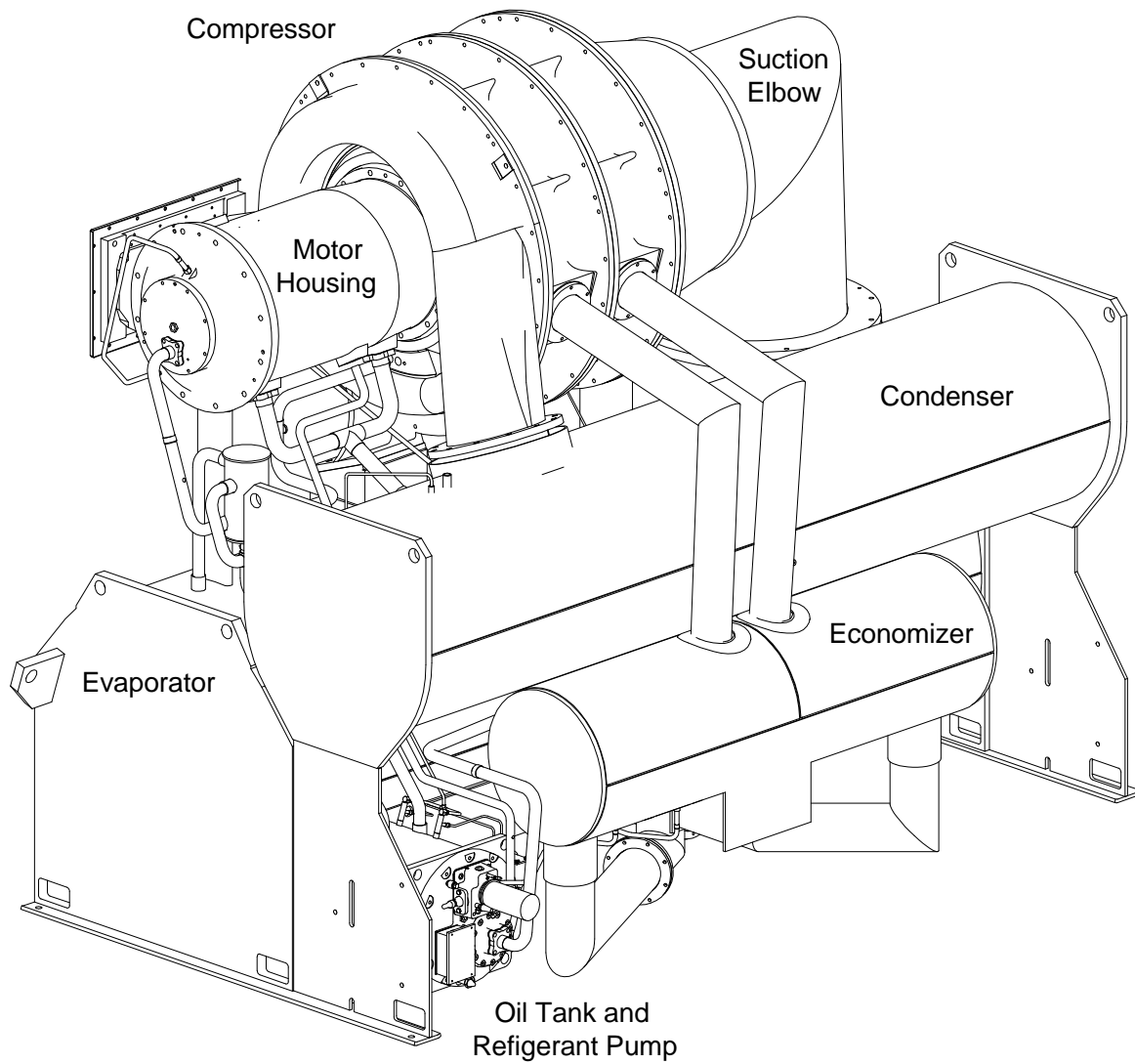

# Mechanical Operation - CVHE, CVHG

Figure 2  
Pressure Enthalpy Curve

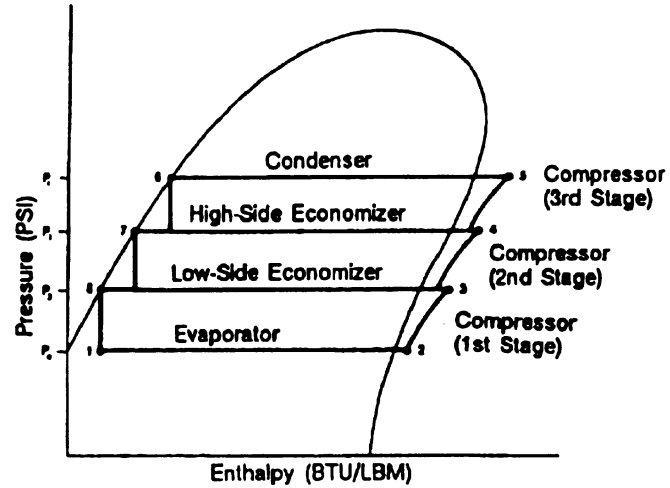
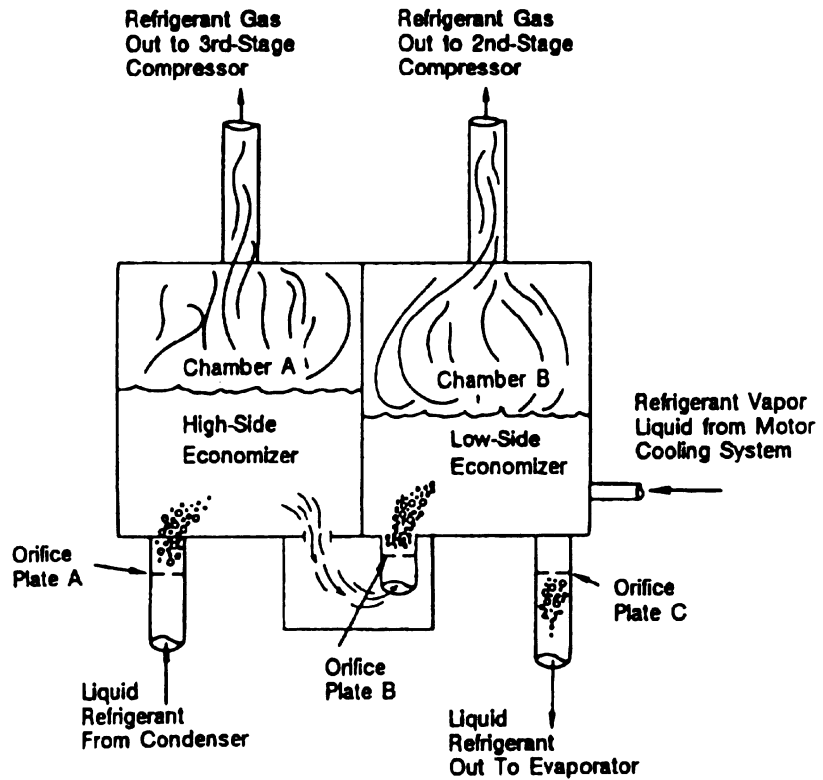

Figure 3  
2-Stage Economizer



# Mechanical Operation - CVHE, CVHG

---

## Units With Refrigeration Pump

### Compressor Lubrication System - CVHE and CVHG

A schematic diagram of the compressor lubrication system is illustrated in Figure 4 for the CVHE and CVHG.

Oil is pumped from the oil tank (i.e., by a pump and motor located within the tank) through an oil pressure-regulating valve designed to maintain a net oil pressure of 18 to 22 psid. It is then filtered and sent to the oil cooler located in the economizer and on to the bearings.

From the bearings, the oil drains back to the manifold under the motor and then on to the oil tank.

 **WARNING**  
**SURFACE TEMPERATURES MAY EXCEED 150°F. Use caution while working on certain areas of the unit, failure to do so may result in death or personal injury.**

To ensure proper lubrication and prevent refrigerant from condensing in the oil tank, a 750-watt heater is immersed in the oil tank and is used to warm the oil while the unit is off. When the unit starts, the oil heater is de-energized. This heater energizes as needed to maintain 140° to 145° F (60-63 C) when the chiller is not running.

When the chiller is operating, the temperature of the oil tank is typically 115° to 160°F (46-72 C). The oil return lines from the thrust and journal bearings, transport oil and some seal leakage refrigerant. The oil return lines are routed into a manifold under the motor. Gas flow exits the top of the manifold and is vented to the Evaporator. A vent line solenoid is not needed with the refrigerant pump. Oil exits the bottom of the manifold and returns to the tank. Separation of the seal leakage gas in the manifold keeps this gas out of the tank.

A dual eductor system is used to reclaim oil from the suction cover and the evaporator, and deposit it back into the oil tank. These eductors use high pressure condenser gas to draw the oil from the suction cover and evaporator to the eductors and then discharged into the oil tank. The evaporator eductor line has a shut off valve mounted by the evaporator and ships with two turns open.

Liquid refrigerant is used to cool the oil supply to both the thrust bearing and journal bearings. On refrigerant pump units the oil cooler is located inside the economizer and uses refrigerant passing from the condenser to evaporator to cool the oil. Oil leaves the oil cooler and flows to both the thrust and journal bearings.

### Motor Cooling System

Compressor motors are cooled with liquid refrigerant, see Figure 4.

The refrigerant pump is located on the front of the oil tank (motor inside the oil tank). The refrigerant pump inlet is connected to the well at the bottom of the condenser. The connection is on the side where a weir assures a preferential supply of liquid. Refrigerant is delivered to the motor via the pump. Motor refrigerant drain lines are routed to the condenser.

# Mechanical Operation - CVHE, CVHG

**Figure 4**  
CVHE and CVHG with Refrigerant Pump

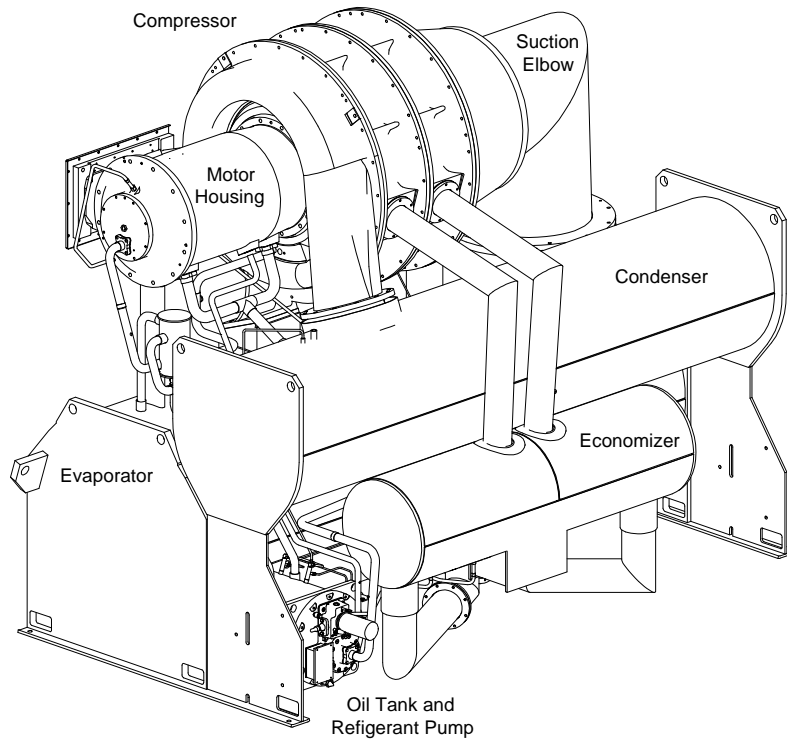

## GENERAL ASSEMBLY OIL/REFRIGERATION SYSTEM SCHEMATIC

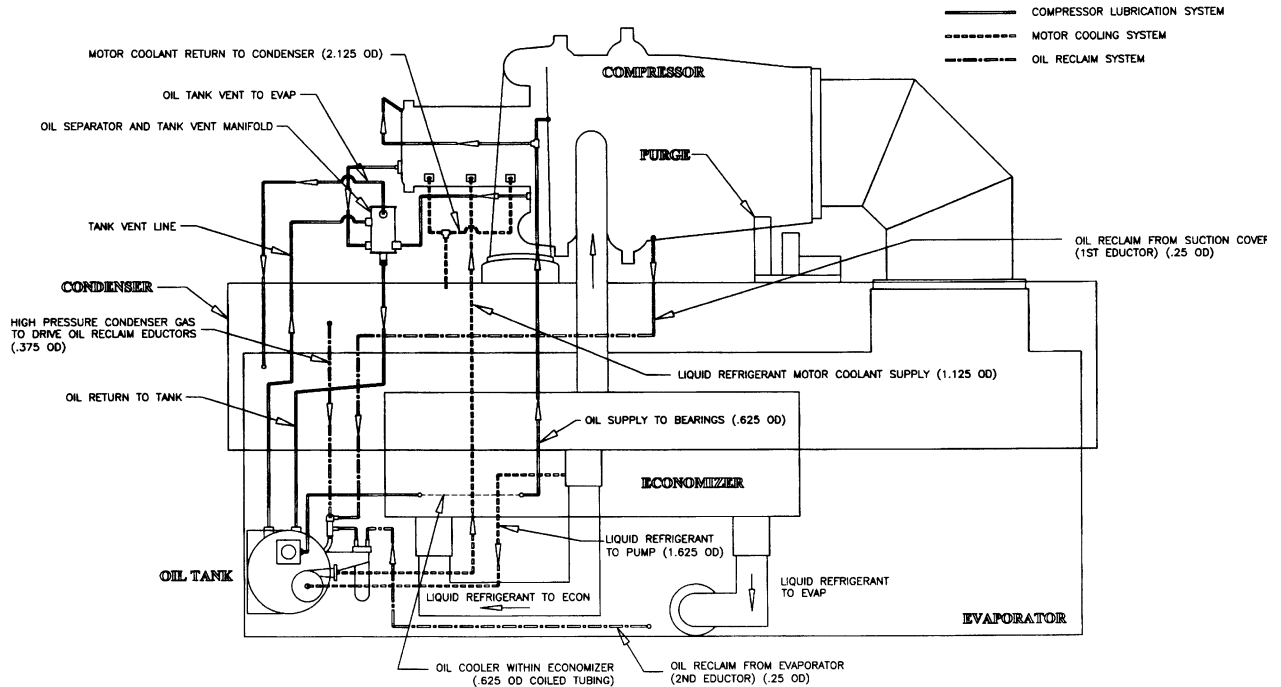

# Mechanical Operation - CVHF

---

## Overview

THE FOLLOWING DESCRIPTION APPLIES TO THE TRANE MODEL CVHF CENTRIFUGAL CHILLER ONLY. Refer to the appropriate operation manual for refrigeration cycle descriptions of other models.

Each CVHF unit is composed of 5 basic components:

- the evaporator
- 2 stage compressor
- water-cooled condenser
- single-stage economizer
- related interconnecting piping

A heat-recovery or auxiliary condenser can be factory-added to the basic unit assembly to provide a heat-recovery cycle.

Figure 5 illustrates the general component layout of a typical CVHF chiller.

CVHF cooling-only and heat recovery modes of operation are described in the following sections. A pressure/enthalpy diagram is provided in Figure 6 to further illustrate unit operation.

## Cooling-Only Cycle

When the CVHF is functioning in the cooling mode, liquid refrigerant is distributed along the length of the evaporator and sprayed through small holes in a distributor (i.e., running the entire length of the shell) to uniformly coat each evaporator tube. Here, the liquid refrigerant absorbs enough heat from the system water circulating through the evaporator tubes to vaporize.

The gaseous refrigerant is then drawn through the eliminators (which remove droplets of liquid refrigerant from the gas), first-stage variable inlet guide vanes, and into the first-stage impeller.

**Note:** Inlet guide vanes are designed to modulate the flow of gaseous refrigerant to meet system capacity requirements; they also prerotate the gas allowing it to enter the impeller at an optimal angle that maximizes efficiency at all load conditions.

Compressed gas from the first-stage impeller is discharged through the second-stage variable guide vanes and into the second-stage impeller. Here, the refrigerant gas is again compressed, and then discharged into the condenser.

Baffles within the condenser shell distribute the compressed refrigerant gas evenly across the condenser tube bundle. Cooling tower water, circulated through the condenser tubes, absorbs heat from the refrigerant, causing it to condense. The liquid refrigerant then flows out of the bottom of the condenser, passing through an orifice plate and into the economizer.

The economizer reduces the energy requirements of the refrigerant cycle by eliminating the need to pass all gaseous refrigerant through both stages of compression. See Figure 7. Notice that some of the liquid refrigerant flashes to a gas because of the pressure drop created by the orifice plate, thus further cooling the liquid refrigerant. This flash gas is then drawn directly from the economizer into the second-stage impellers of the compressor. All remaining liquid refrigerant flows out of the economizer, passes through another orifice plate and into the evaporator.

**Note:** See Figure 8 for a unit with Refrigerant pump.

# Mechanical Operation - CVHF

---

Figure 5  
General CVHF Components

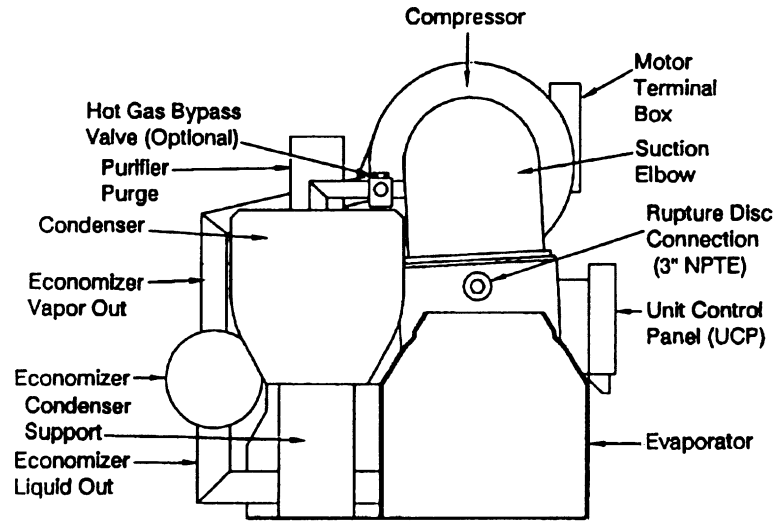

# Mechanical Operation - CVHF

Figure 6  
CVHF Pressure Enthalpy Curve

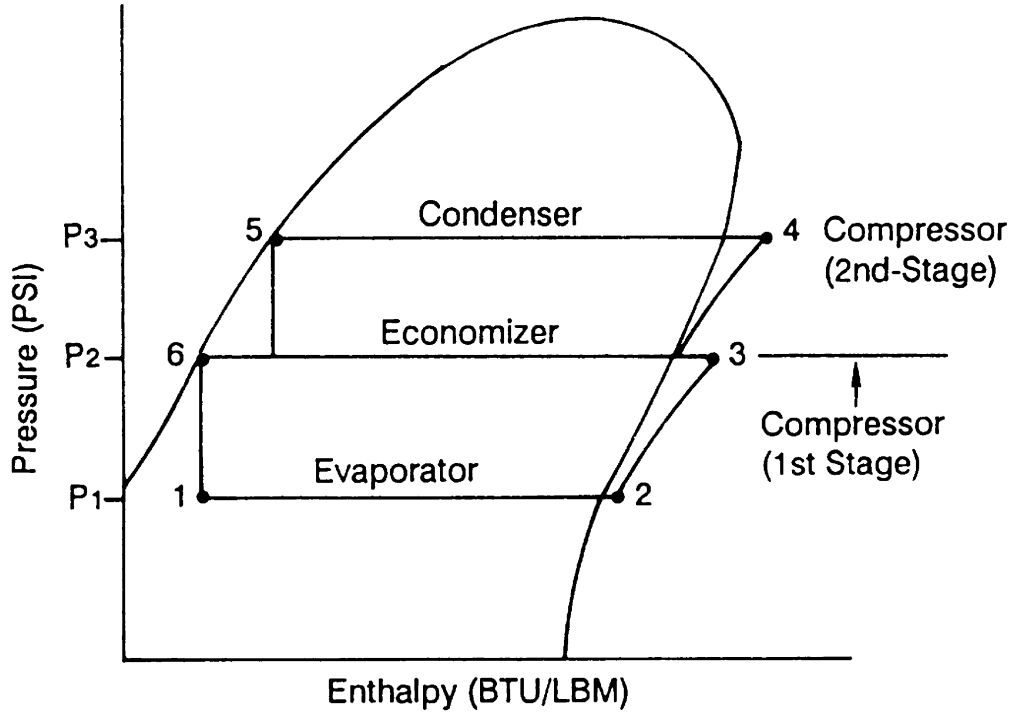
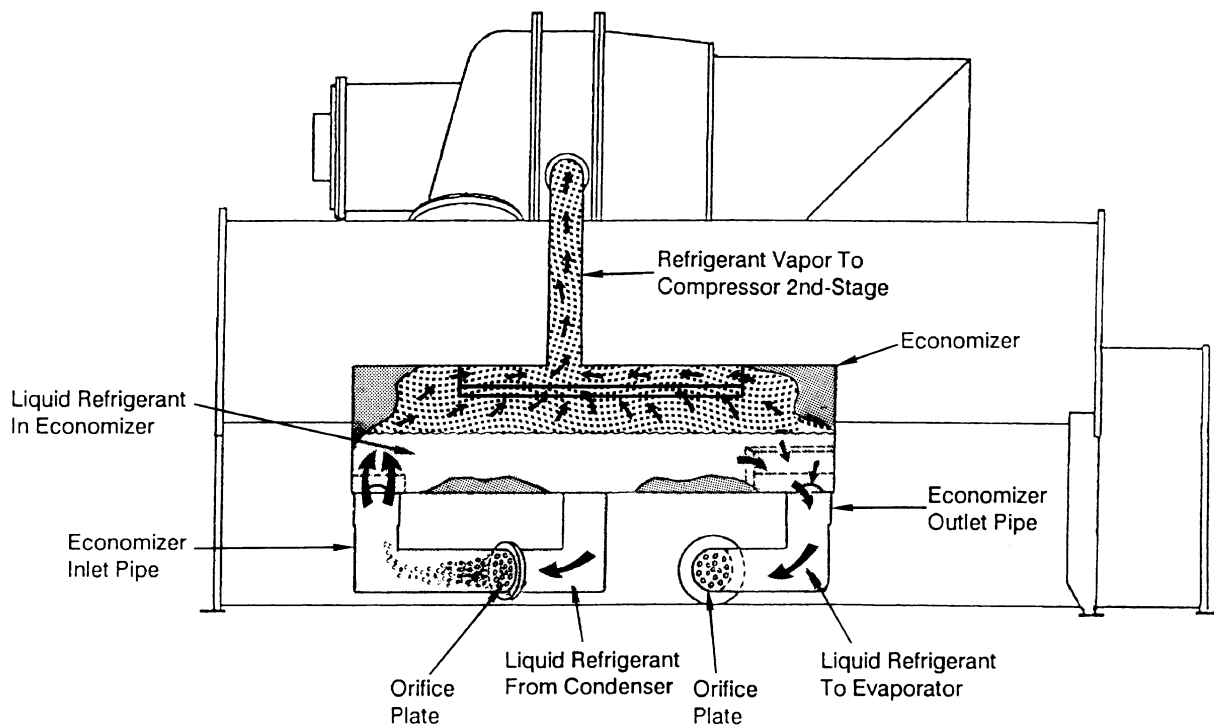
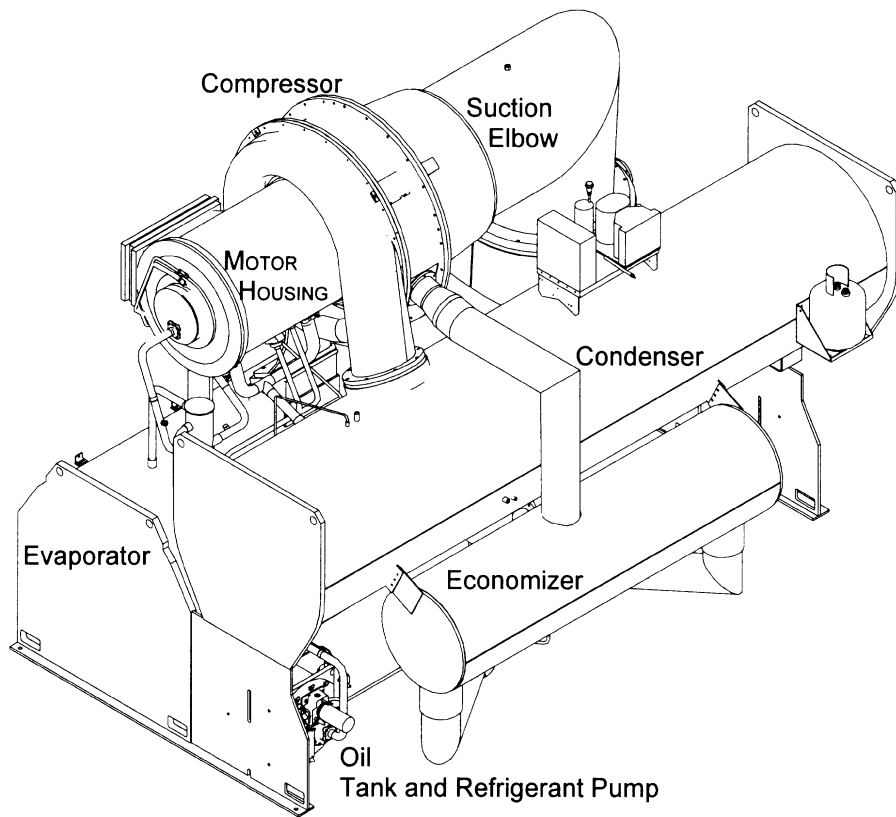

Figure 7  
CVHF Economizer Operation



# Mechanical Operation - CVHF

Figure 8 - CVHF Unit With Refrigerant Pump



## GENERAL ASSEMBLY OIL/REFRIGERATION SYSTEM SCHEMATIC

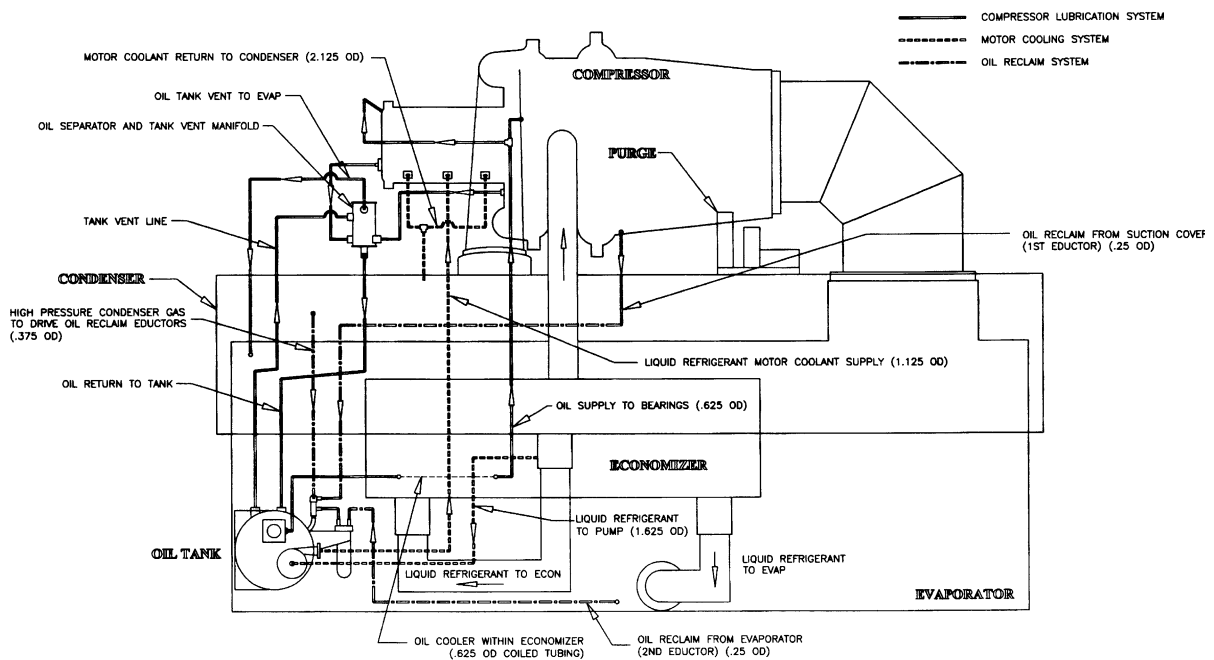

# Mechanical Operation - CVHF

---

## CVHF Units With Refrigerant Pump

### Compressor Lubrication System - CVHF

A schematic diagram of the compressor Refrigerant/Oil lubrication system is illustrated in Figure 8 for the CVHF.

Oil is pumped from the oil tank through an oil pressure regulating valve designed to maintain a net oil pressure of 18 to 22 psid. It is then filtered and sent to the oil cooler and on to the bearings.

From the bearings, the oil drains back to the manifold under the motor and then on to the oil tank.



#### WARNING

**SURFACE TEMPERATURES MAY EXCEED 150 F. USE CAUTION WHILE WORKING ON CERTAIN AREAS OF THE UNIT, FAILURE TO DO SO MAY RESULT IN DEATH OR PERSONAL INJURY.**

To ensure proper lubrication and prevent refrigerant from condensing in the oil tank, a 750 watt heater is immersed in the oil tank and is used to warm the oil while the unit is off. When the unit starts, the oil heater is de energized. This heater energizes as needed to maintain 140 F to 145 F (60 to 63 C) when the chiller is not running.

When the chiller is operating, the temperature of the oil tank is typically 115 F to 160 F (46 to 72 C). The oil return lines from the thrust and journal bearings, transport oil and some seal leakage refrigerant. The oil return lines are routed into a manifold under the motor. Gas flow exits the top of the manifold and is vented to the Evaporator. A vent line solenoid is not needed with the refrigerant pump. Oil exits the bottom of the manifold and returns to the tank. Separation of the seal leakage gas in the manifold keeps this gas out of the tank.

A dual eductor system is used to reclaim oil from the suction cover and the evaporator, and deposit it back into the oil tank. These eductors use high pressure condenser gas to draw the oil from the suction cover and evaporator back to the eductors and then discharged into the oil tank. The evaporator eductor line has a shut off valve mounted by the evaporator and ships with two turns open.

Liquid refrigerant is used to cool the oil supply to both the Thrust bearing and Journal bearing on larger units (360 ton and larger). On refrigerant pump units the oil cooler is located inside the economizer and uses refrigerant passing from the condenser to evaporator to cool the oil. Oil leaves the oil cooler and flows to both the thrust and journal bearings.

## Motor Cooling System

Compressor motors are cooled with liquid refrigerant, See Figure 8.

The refrigerant pump is located on the front of the oil tank (motor inside the oil tank). The refrigerant pump inlet is connected to the well at the bottom of the condenser. The connection is on the side where a weir assures a preferential supply of liquid. Refrigerant is delivered to the motor via the pump and delivered to the same connection as used on units without the refrigerant pump. Motor refrigerant drain lines are routed to the condenser.

# Options - CVHE, CVHF, CVHG

---

## Free Cooling Cycle CVHE, CVHF and CVHG

Based on the principle that refrigerant migrates to the coldest area in the system, the free cooling option adapts the basic chiller to function as a simple heat exchanger. However, it does not provide control of the leaving chilled water temperature.

If condenser water is available at a temperature lower than the required leaving chilled water temperature, the operator manually stops the compressor and starts the free cooling cycle by enabling the Free cooling mode in the "Operator Settings" Group of the Human Interface.

Several components must be factory-supplied or field-installed to equip the unit for free cooling operation:

- options module 1U5
- a refrigerant gas line, including an electrically-actuated shutoff valve, between the evaporator and condenser;
- a valve liquid return line, including an electrically-actuated shutoff valve, between the condenser sump and the evaporator;
- a liquid refrigerant storage vessel; and,
- additional refrigerant.

When the chiller operator initiates changeover to the free cooling mode, the compressor will shut down if running, the shutoff valves in the liquid and gas lines open; UCP (i.e., unit control panel) control logic prevents the compressor from energizing during free cooling. Liquid refrigerant then drains (by gravity) from the storage tank into the evaporator and floods the tube bundle.

Since the temperature and pressure of the refrigerant in the evaporator are higher than in the condenser (i.e., because of the difference in water temperature), the refrigerant in the evaporator vaporizes and travels to the condenser. Cooling tower water causes the refrigerant to condense, and it flows (again, by gravity) back to the evaporator.

This compulsory refrigerant cycle is sustained as long as a temperature differential exists between condenser and evaporator water. The actual cooling capacity provided by the free cooling cycle is determined by the difference between these temperatures which, in turn, determines the rate of refrigerant flow between the evaporator and condenser shells.

If the system load exceeds the available free cooling capacity, the operator must manually initiate changeover to the mechanical cooling mode by disabling the free cooling mode in the "Operator Settings" Group of the Human Interface. The gas and liquid line valves then close and compressor operation begins. Refrigerant gas is drawn out of the evaporator by the compressor, where it is then compressed and discharged to the condenser.

Most of the condensed refrigerant initially follows the path of least resistance by flowing into the storage tank. This tank is vented to the economizer sump through a small bleed line; when the storage tank is full, liquid refrigerant must flow through the bleed line restriction. Because the pressure drop through the bleed line is greater than that of the orifice flow control device, the liquid refrigerant flows normally from the condenser through the orifice system and into the economizer.

**Note:** During changeover from free cooling to mechanical cooling, the refrigerant transfer process is completed within three minutes. The micro-computer-based control system prevents carry-over by not allowing the unit to load for a period of two minutes.

# Options - CVHE, CVHF, CVHG

---

## Heat Recovery Cycle

“Heat recovery” is designed to salvage the heat that is normally rejected to the atmosphere through the cooling tower, and put it to beneficial use.

For example, a high-rise office building may require simultaneous heating and cooling during the winter months. With the addition of a heat recovery cycle, heat removed from the building cooling load can be transferred to areas of the building that require heat. (Keep in mind that the heat recovery cycle is only possible if a cooling load exists to act as a heat source.)

To provide a heat recovery cycle, a heat-recovery condenser is added to the unit; see Figure 2. Though physically identical to the standard cooling condenser, the heat-recovery condenser is piped into a heat circuit rather than to the cooling tower.

During the heat recovery cycle, the unit operates just as it does in the “cooling only” mode except that the cooling load heat is rejected to the heating water circuit rather than to the cooling tower water circuit.

When hot water is required, the heating water circuit pumps energize. Water circulated through the heat-recovery (or auxiliary) condenser tube bundle by the pumps absorbs cooling-load from the compressed refrigerant gas discharge by the compressor. The heated water is then used to satisfy heating requirements.

## Auxiliary Condensers

Unlike the heat-recovery condenser (which is designed to satisfy comfort heating requirements), the auxiliary condenser serves a preheat function only, and is used in those applications where hot water is needed for use in kitchens, lavatories, etc. While the operation of the auxiliary condenser is physically identical to that of the heat-recovery condenser, it is comparatively smaller in size, and its heating capacity is not controlled.

**Trane does not recommend operating the auxiliary condenser alone because of its small size.**

## Ice Machine Control

UCP2 provides a service level “Enable/Disable” menu entry for the Ice Building feature when the Ice Building option is installed. UCP2 will accept either an isolated contact closure (J3, 7 & 8 on the options module) or a remote communicated input (Tracer) to initiate the ice building mode where the unit runs fully loaded at all times. Ice building will be terminated either by opening the contact or based on entering evaporator water temperature. UCP2 will not permit the Ice Building mode to be entered again until the unit is switched to the Non-ice building mode and back into the ice building mode. It is not acceptable to reset the chilled water setpoint low to achieve a fully loaded compressor.

When entering ice-building the compressor will be loaded at its maximum rate and when leaving ice building the compressor will be unloaded at its maximum rate. While loading and unloading the compressor, all surge detection will be ignored.

While in the ice building mode, current limit setpoints less than the maximum will be ignored. Ice Building can be terminated by one of the following means:

1. Opening the external Ice Contacts/Remote communicated input (Tracer).
2. Satisfying an evaporator entering water temperature setpoint.
3. Surging for 15 minutes at full open IGV.

# Options - CVHE, CVHF, CVHG

---

## Base Loading

### Tracer Base Loading:

**Current Setpoint Range:  
(20 - 100) % RLA**

The tracer commands the chiller to enter the base load mode by setting the base load mode request bit to 1. If the chiller is not running, it will start regardless of the differential to start (either chilled water or hot water). If the chiller is already running, it will continue to run regardless of the differential to stop (either chilled water or hot water), using the base load control algorithm. While the unit is running in base loading, it will report that status back to the tracer by setting "Base Load Status = true" in the Tracer Status Byte. When the tracer removes the base load mode request (sets the bit to 0). The unit will continue to run, using the normal chilled or hot water control algorithm, and will turn off, only when the differential to stop has been satisfied.

### External Base Loading:

**Current Setpoint Range:  
(20 - 100) % RLA**

The chiller module accepts 2 inputs to work with external base loading. The first input is on chiller module terminals J7-1 and J7-2. This input looks for a switch closure to enter the base-loading mode. The second input is found on chiller module terminals J7-11 and J7-12. This input selects the base loading setpoint, and can be controlled by either a 2-10Vdc or 4-20ma Signal. To use a 2-10Vdc input, dip switch 2-1 should be in the 'OFF' position. To use a 4-20mA input, dip switch 2-1 should be in the 'ON' Position. You must also set the correct input type in the Machine Configuration menu. This menu is titled "External Setpoints Input". The graphs in Figure 9 show the relationship between input and % RLA.

While in base loading the active current limit setpoint is set to the tracer or external base load setpoint, providing that the base load setpoint is not equal to 0 (or out of range). If it is out of range, the front panel current limit setpoint is used. During base loading, all limits are enforced with the exception of current limit. The human interface displays the message "Unit is Running Base Loaded". Hot Gas Bypass is not run during base loading. If base loading and ice making are commanded simultaneously, ice making takes precedence.

### Base Loading Control

#### Algorithm:

Base Loading Control is basically a variation of the current limit algorithm. During base loading, the leaving water control algorithm provides a 1250 step load command every 5 seconds. The current limit routine limits the loading when the current is below setpoint. When the current is within the deadband of the setpoint the current limit algorithm holds against this loading command. If the current exceeds the setpoint, the current limit algorithm unloads. The "Capacity Limited By High Current" message normally displayed while the current limit routine is active is suppressed while base loading.



### Unit Mounted Refrigerant Monitor

Refer to RMWD-IOM-1D or the most current revision. This can be obtained from the nearest Trane office in your area.

### Unit Mounted Adaptive Frequency™ Drive

The AFDB, is a water-cooled pulse width modulated inverter. The function of the inverter is to change a DC input voltage to a symmetrical AC output voltage of desired magnitude and frequency. It is designed for 460/480-volt application. Circuit breakers, surge capacitors and ground faults are standard on all AFDB units. The CTV unit control panel has full control of the AFDB unit operation, including the start/stop functions. AFDB-OM-1C (or most recent revision) covers the features and specifications of the Trane Adaptive Frequency drive.

# Options - CVHE, CVHF, CVHG

Figure 9  
Base Loading with External mA Input and with External Voltage Input

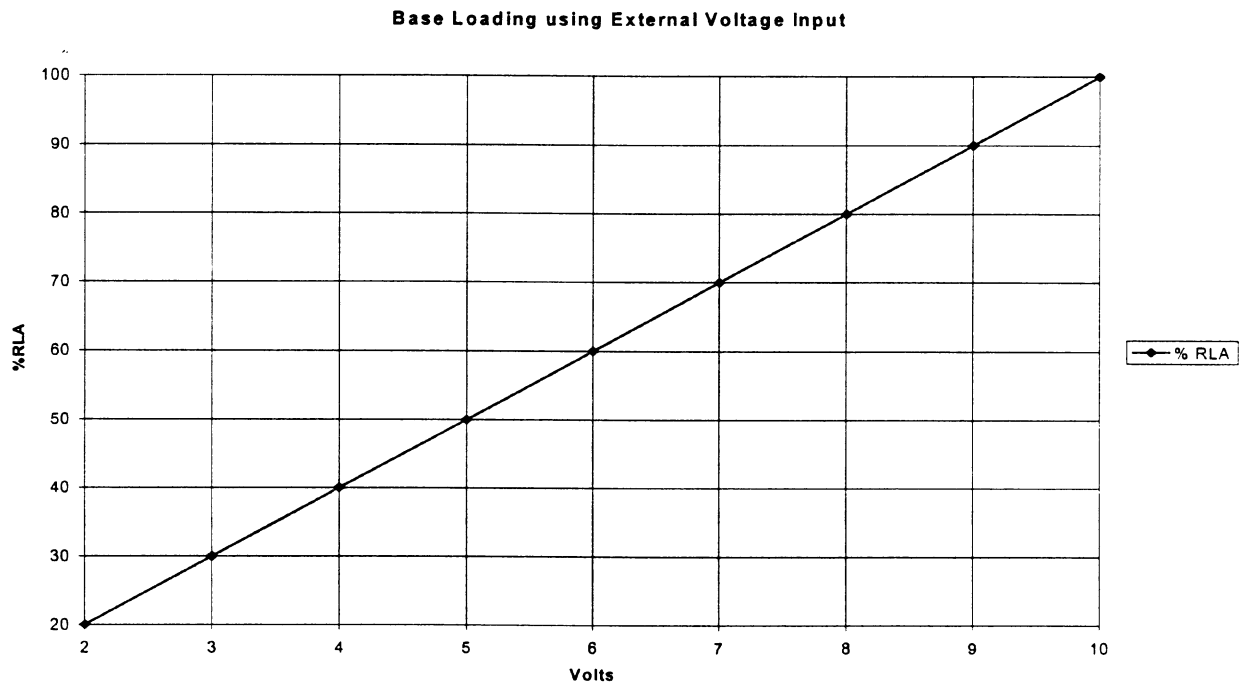
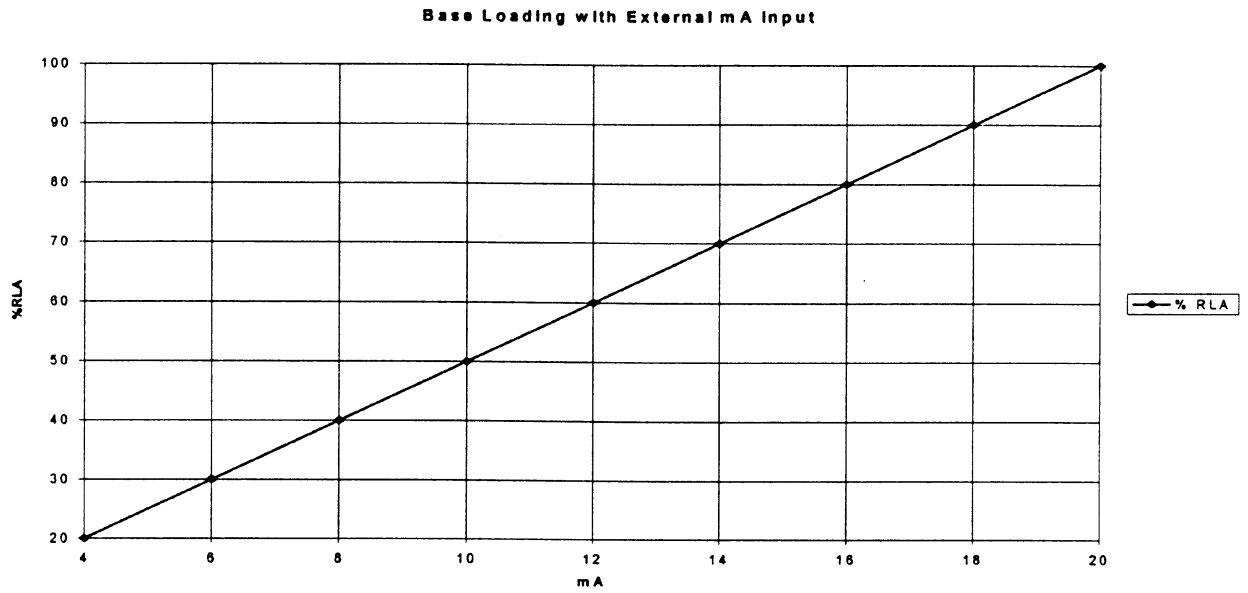

# Chiller Control System

## Unit Control Panel

The UCP2 control, see Figure 10, consists of a modular design partitioned by major function or group of functions. All modules communicate with each other through the IPC circuit.

Major components within each of these control groups are described below.

Unit-mounted temperature sensors, pressure transducers and functional switches provide analog and binary inputs to the various modules.

The "microcomputer-based" modules are described below. All wiring to the modules are to pluggable terminal blocks.

## Chiller Module (1U1)

The Chiller Module, located in the UCP2 control panel, is the "Master" of the chiller communicating commands to other modules and collecting data, status and diagnostic information from the other modules over the IPC (Inter Processor Communications) link. The Chiller Module performs the Leaving Chilled Water Temperature and Limit Control Algorithms arbitrating capacity against any operating limit the chiller may find itself working against. The Chiller module contains non-volatile memory both checking for valid set points and retaining them on any power loss.

Inputs and outputs are chilled water system level inputs and outputs including evaporator and condenser water temperatures, outdoor air temperature, evaporator and condenser water pump control, status and alarm relays, external auto-stop, emergency stop, evaporator and condenser water pressure drops and evaporator and condenser water flow switches. Connection points of standard and optional inputs and outputs for the chiller module (1U1) are shown in Figure 11.

For more information regarding the UCP2 control module screens, refer to CVHE-CLD-1A or later revision, which is the Clear Language Display manual that ships with CVHE, CVHF and CVHG units from the factory. This manual also may be obtained from the nearest Trane office.

**Figure 10**  
**UCP2 Control Panel**

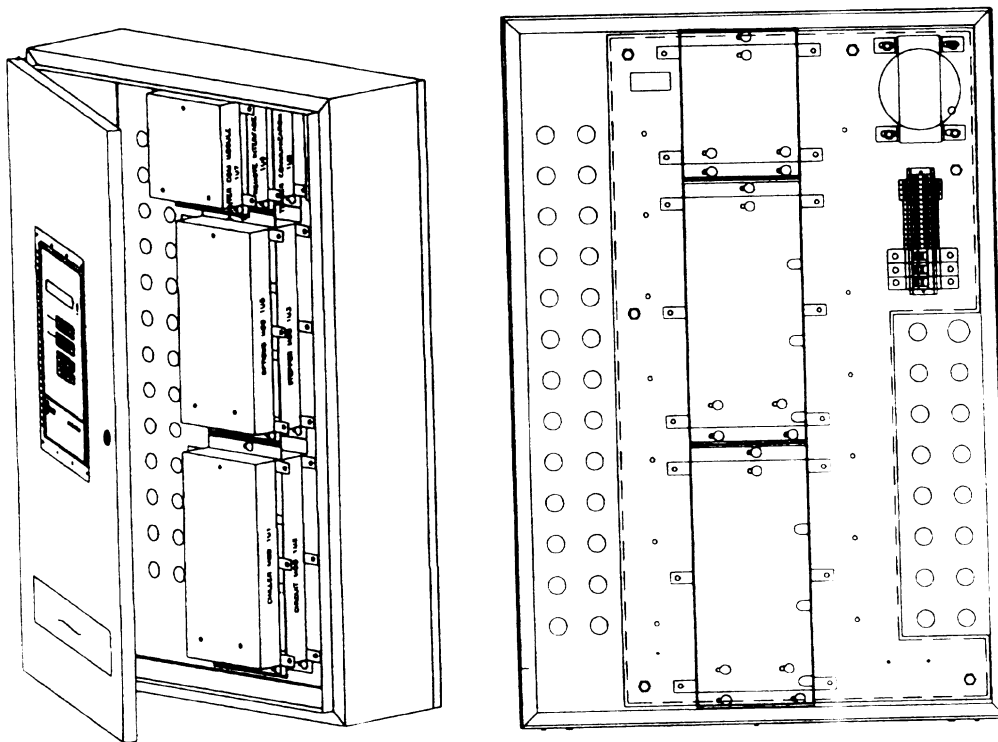

# Chiller Controls System

Figure 11 - Chiller Module (1U1) - CVHE, CVHF and CVHG

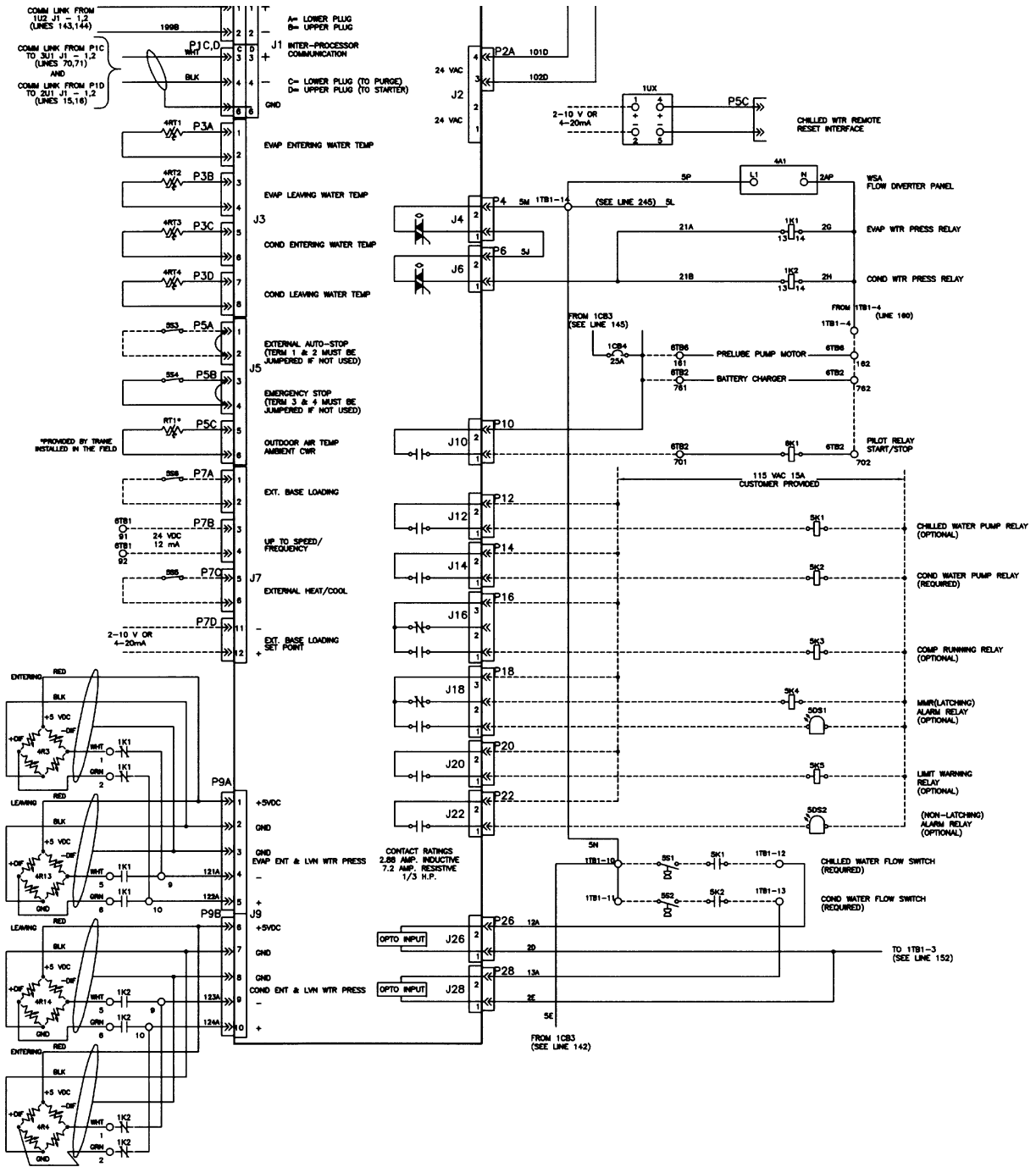

# Chiller Control System

---

## Circuit Module (1U2)

The Circuit Module serves as an input/output expander and has inputs and outputs associated with motor, refrigerant and lubrication functions. These include, motor winding temperatures, oil temperature, refrigerant monitor connection, optional condenser refrigerant pressure, oil sump pressure, oil pump discharge pressure, vent line valve operation, oil tank heater operation, oil pump and oil pump/refrigerant pump on units with the refrigerant pump.

Note: The oil heater no longer needs to run when the unit is running. When the unit is OFF, the heater will be ON.

You will notice that the oil sump may run colder when the unit is running and the oil heater is OFF. The oil sump temperature will operate at oil saturated evaporator temp plus 30° F (16.6°C).

Connection points of inputs and outputs for the Circuit Module (1U2) are shown in Figure 18.

Figure 18 shows Circuit Module with a Refrigerant Pump.

## Stepper Module (1U3)

Note: The CVHF 1470/1720 Stepper Module drives two actuators, one for each compressor stage. The Stepper Module determines the direction and distance to drive the second actuator based on the Chiller Module's command to drive the First Actuator.

The Stepper Module drives the stepper motor inlet guide vane actuator on CenTraVac® Chillers. The Stepper Module receives from the Chiller Module the direction and distance to drive the inlet guide vanes and then generates the appropriate signals to operate the stepper motor.

The Stepper Module has inputs and outputs used to support functions on the module. These include saturated evaporated refrigerant temperature, bearing temperatures, compressor discharge temperature, inlet guide vane binary position indicator (B.P.I.), and saturated condenser refrigerant temperature.

Connection points of inputs and outputs of the Stepper Module (1U3) are shown in Figure 12 and include CVHF 1470 and 1720.

## Clear Language Display Module (1U4)

The Clear Language Display Module, located on the UCP2 control panel door, provides display of chiller data and access to operator/serviceman controls, set points and chiller setup information. All information is stored in non-volatile memory in the Chiller Module. The Clear Language Display and the Chiller Module work together to display and store information requiring non-volatility. The connections to the Clear Language Display Module (1U4) are shown in Figure 13. The front face of the Clear Language Display Module consists of a LCD Display, a LED, and a keypad. The LCD Display presents the operating status of the unit, operating set points, operating conditions, unit configurations, purge operating conditions, diagnostics, unit configuration, and service test in a clear language display.

The LED is red in color and will only be "ON" when a manual reset is required to restore the unit to full operation. The keypad has 16 keys arranged in a 4 c 4 matrix. See CVHE-CLD-1A or latest revision for operation and set-ups on the Clear Language Display.

# Chiller Controls System

---

## Options Module (1U5)

The Options Module provides control or interface requirements for a number of options. Features supported by the Options Module include Ice-Making, Heat Recovery, External Chilled Water Setpoint, External Current Limit Setpoint, Free Cooling, Evaporator Differential Water Pressure Drop, Condenser Differential Water Pressure Drop Percent RLA of Compressor, Tracer Temperature Sensor, Head Relief Request, Maximum Capacity Relay, and Tracer Controlled Relay. Connection points of inputs and outputs of the Options Module (1U5) are shown in Figure 14.

## Starter Module (2U1)

The Starter Module located in the Compressor Motor Starter Panel provides control of the starter when starting, running and stopping the motor. The Starter Module provides interface to and control of the Y-Delta, X-Line, P-Reactor, A-Transformer and Solid State Starters; interface to and control of Adjustable Speed Drives is also supported.

The Starter Module also provides protection to both the motor and the compressor in the form of starting and running overload, phase reversal, phase loss, phase unbalance, momentary power loss and compressor surge. Typical wiring connections to the Starter Module are shown in Figures 16 and 17.

## Purge Module (3U1)

The Purge Module provides control of the Purge used on CVHE, CVHF and CVHG units. The Purge Module provides all the inputs and Outputs to control the purge, optimizing both purge and chiller efficiency. The Purge Module resides in the purge control panel and communicates with the Chiller Module over the IPC (Inter-Processor Communications Link) uploading setpoints and downloading data and diagnostics. Connection points of the input and outputs to the Purge Module are shown in Figure 15.

# Chiller Control System

Figure 12 - Stepper Control Module (1U3) - CVHE, CVHF and CVHG (Continued on Next Page)

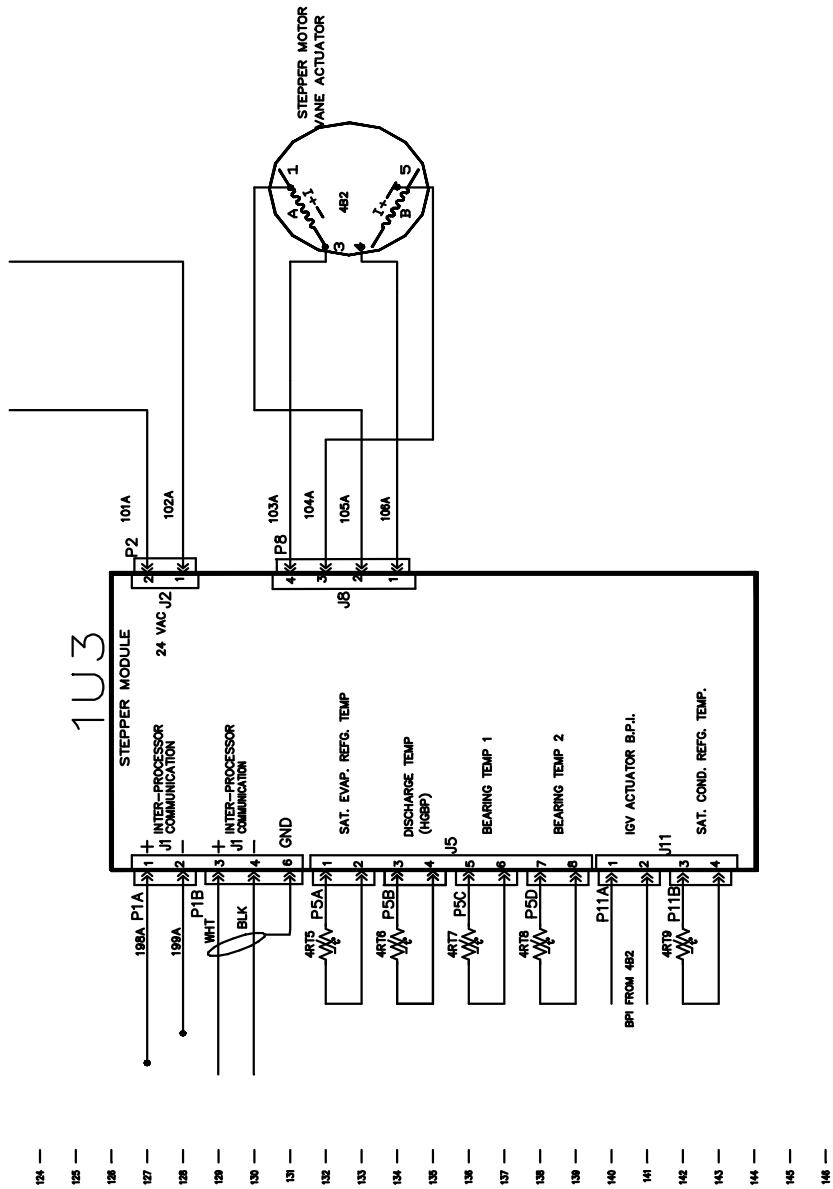

# Chiller Controls System

Figure 12 - Stepper Control Module (1U3) - CVHF Models 1470 and 1720

DRAWING NUMBER  
2307-5240  
REV  
A

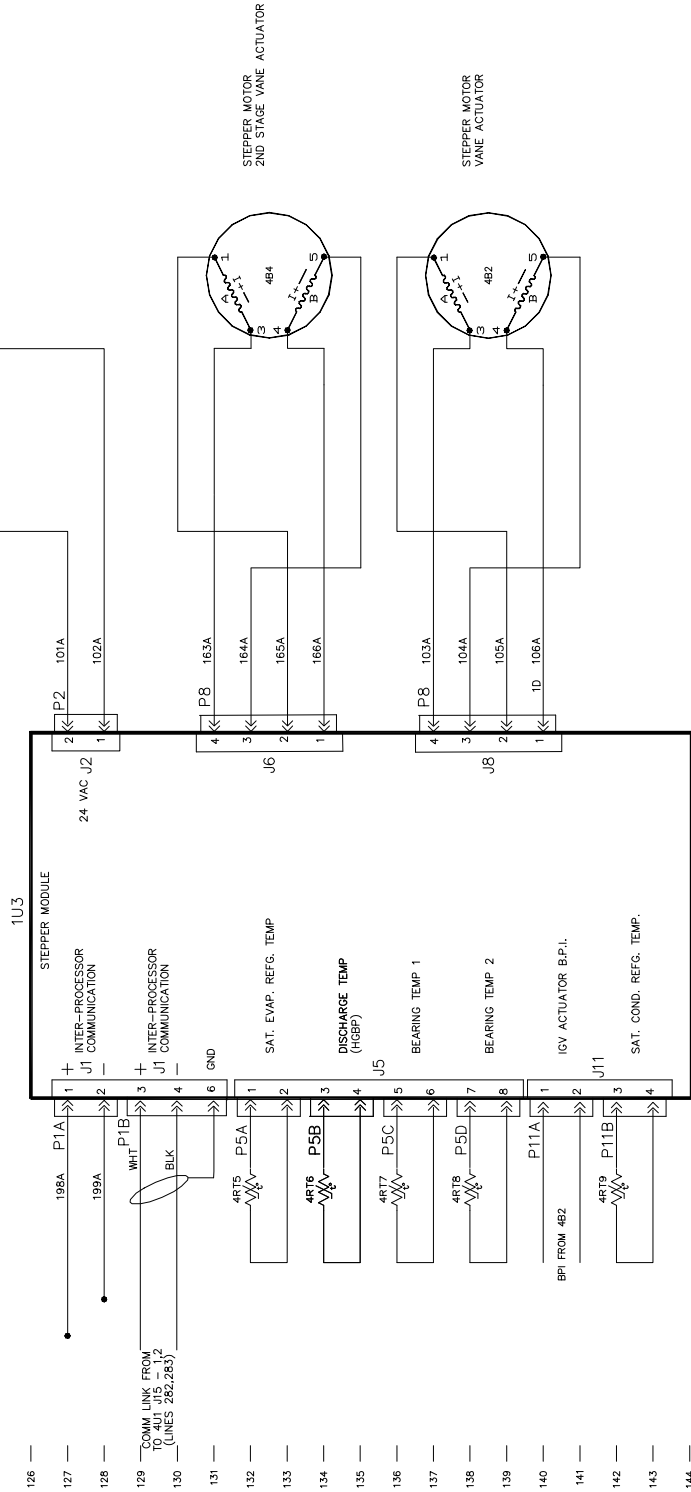

# Chiller Control System

Figure 13 - Clear Language Display Module (1U4) - CVHE, CVHF and CVHG

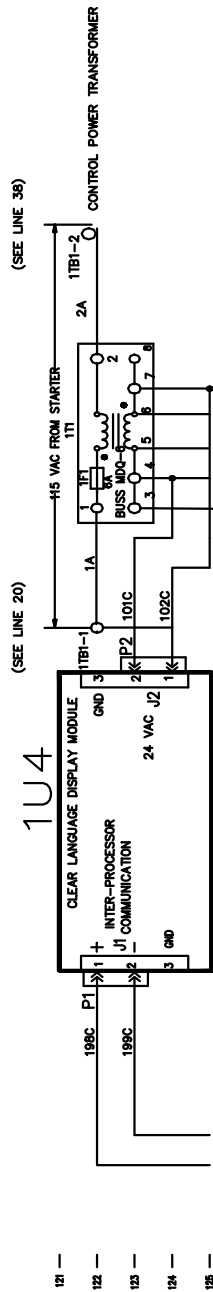

# Chiller Control System

Figure 14 - Options Control Module (1U5) CVHE, CVHF and CVHG

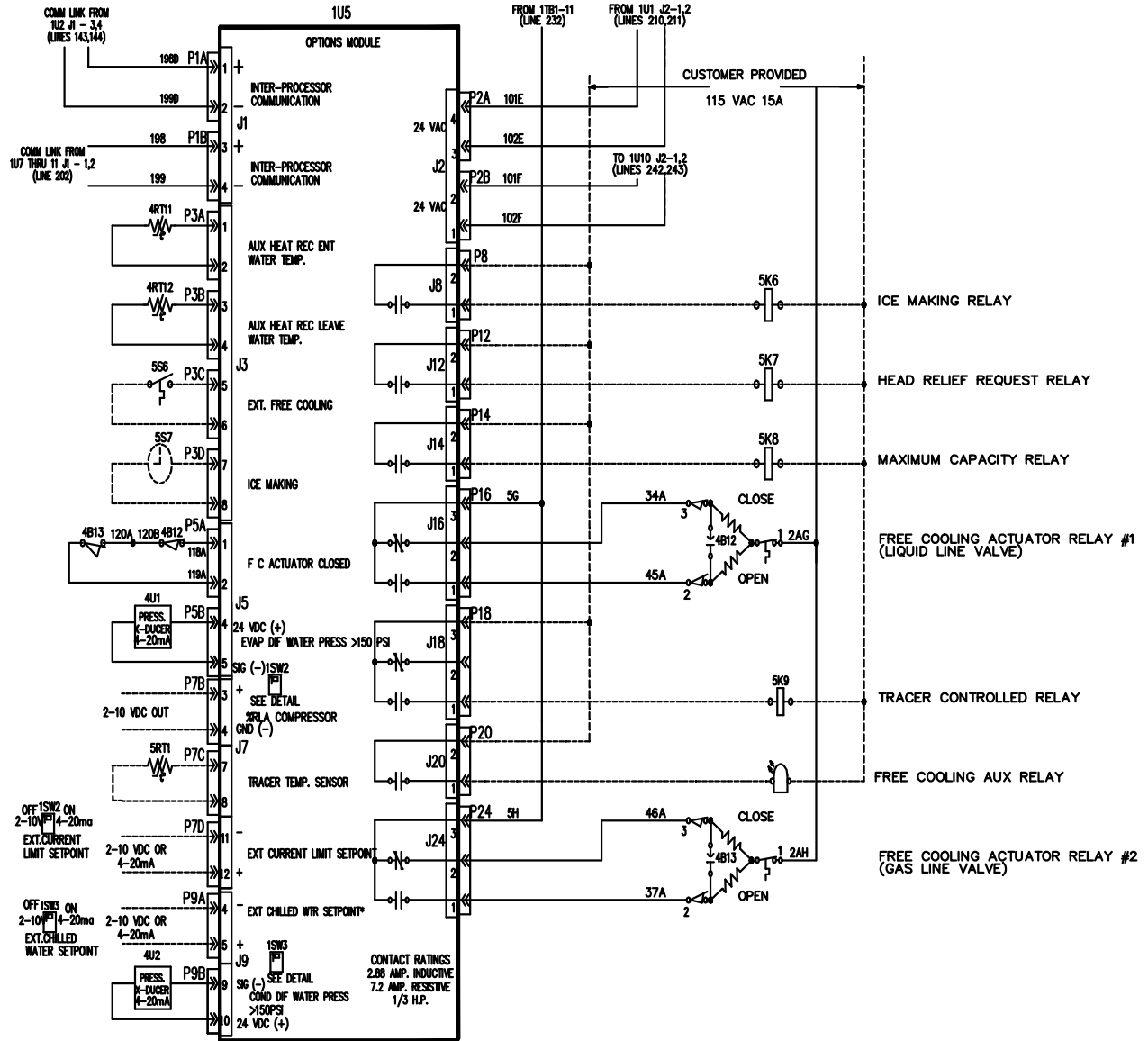

# Chiller Controls System

Figure 15 - Purge Module (3U1) - CVHE, CVHF and CVHG

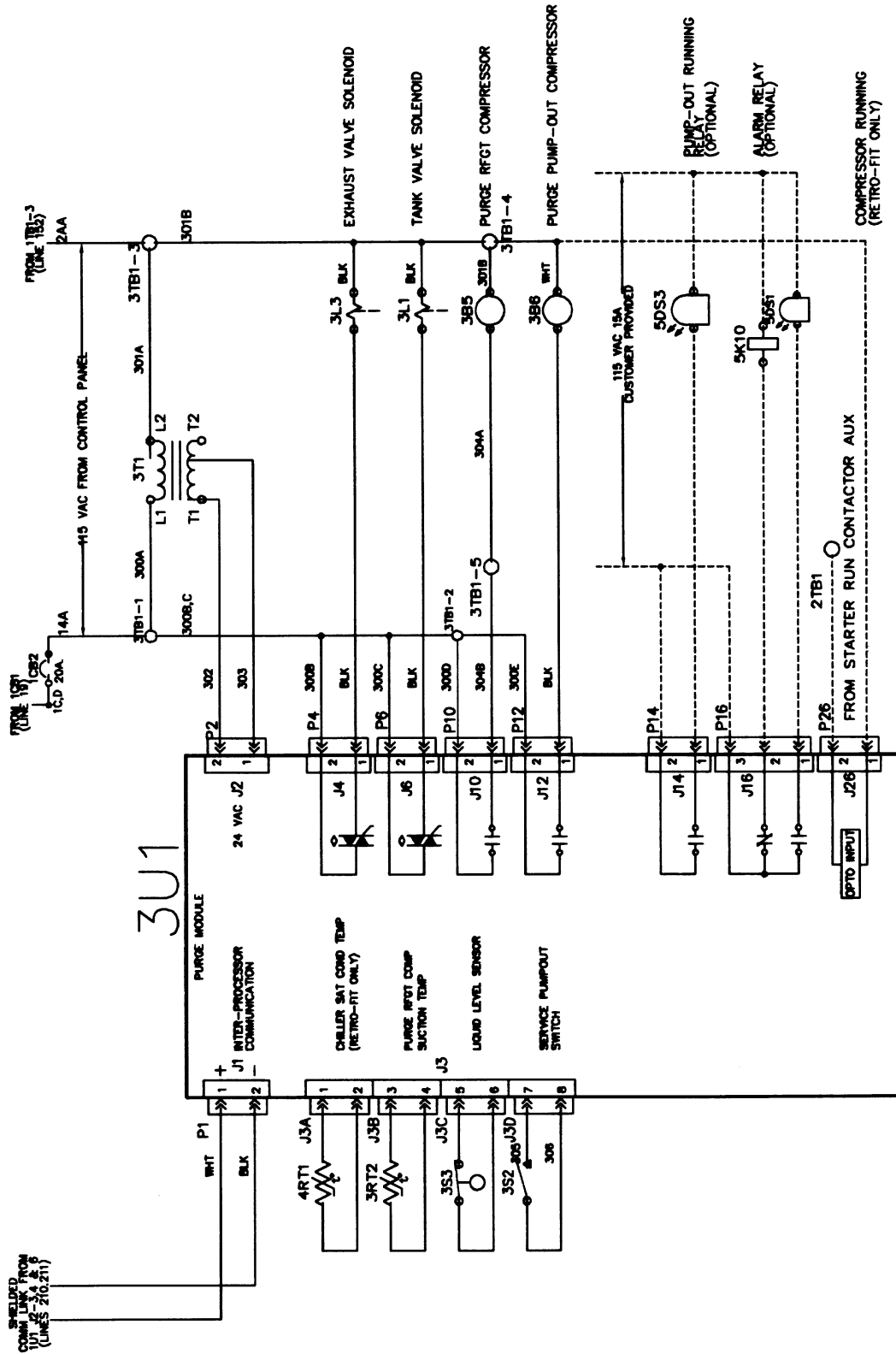



# Chiller Controls System

Figure 16 - Continued - Customer Supplied Remote Mounted Across the Line Starter

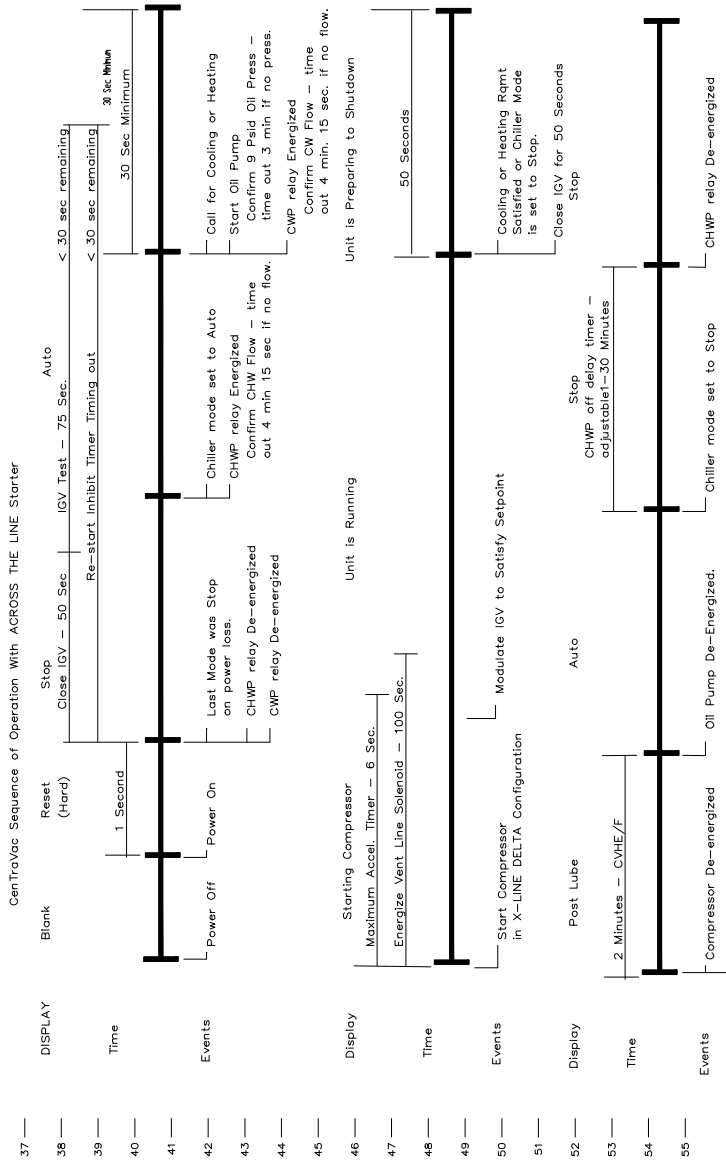

THIS DRAWING IS PROPRIETARY AND SHALL NOT BE COPIED, REPRODUCED, OR TRANSMITTED IN ANY FORM OR BY ANY MEANS, WITHOUT THE WRITTEN CONSENT OF THE TRANE COMPANY.

<p><b>⚠ WARNING</b></p> <p>HAZARDOUS VOLTAGE!</p> <p>DISCONNECT ALL ELECTRIC POWER BEFORE SERVICING.</p> <p>FAILURE TO DISCONNECT POWER BEFORE SERVICING MAY CAUSE SEVERE PERSONAL INJURY OR DEATH.</p> <p><b>AVERTISSEMENT</b></p> <p>VOLTAGE HAZARDEUX!</p> <p>DECONNECTEZ TOUTES LES SOURCES ÉLECTRIQUES INCLUANT LES ÉLÉMENTS DE LA SOURCE D'AVANT D'EFFECTUER L'ENTRETIEN.</p> <p>FAUTE DE DÉCONNECTER LA SOURCE ÉLECTRIQUE AVANT D'ENTREPRENDRE LES TRAVAUX PEUT ENTRAÎNER DES BLESSURES CORPORELLES SÈVES OU LA MORT.</p>	<p><b>⚠ CAUTION</b></p> <p>USE COPPER CONDUCTORS ONLY!</p> <p>UNIT TERMINALS ARE NOT DESIGNED FOR OTHER TYPES OF CONDUCTORS.</p> <p>FAILURE TO DO SO MAY CAUSE DAMAGE TO THE EQUIPMENT.</p>
--	---

- NOTES:
1. OPTIONAL STARTER INTERLOCK. SEE STARTER MANUFACTURER'S WIRING DIAGRAM FOR SPECIFIC APPLICATION.
  2. UNLESS OTHERWISE NOTED, ALL SWITCHES ARE SHOWN AT 25°C (77°F), AT ATMOSPHERIC PRESSURE, AT 50% RELATIVE HUMIDITY, WITH ALL UTILITIES TURNED OFF, AND AFTER A 30-MINUTE DELAY FROM THE TIME OF THE SCHEMATIC NUMBERS ALONG THE RIGHT SIDE OF THE SCHEMATIC.
  3. DESIGNATE THE LOCATION OF THE CONTACTS BY LINE NUMBER, AN UNDERLINED NUMBER INDICATES A NORMALLY CLOSED CONTACT.
  4. THREE PHASE POWER SUPPLY VOLTAGE—SEE UNIT NAMEPLATE.
  5. REMOTE ACROSS THE LINE STARTER WIRING BETWEEN STARTER MANUFACTURER'S WIRING DIAGRAM AND SPECIFIC STARTER WIRING. WIRING DIAGRAM FOR SPECIFIC STARTER WIRING.
  6. RELAY COILS ARE NOT SHOWN. CONTACTS ARE CONTROLLED BY THE LOGIC OF THE MICRO-CONTROLLER. SEE SEQUENCE OF OPERATION.
  7. POLARITY MARKING ON THE CURRENT TRANSFORMER (THE MARKING ON IT) MUST BE FACING TOWARDS THE INCOMING CURRENT.

# Chiller Control System

Figure 17 - Trane Supplied Remote Mounted Wye-Delta Starter Continued

2307-5204 A

UCP2 SCHEMATIC WIRING CVHE, CVHF, CVHG  
REMOTE WYE-DELTA STARTER

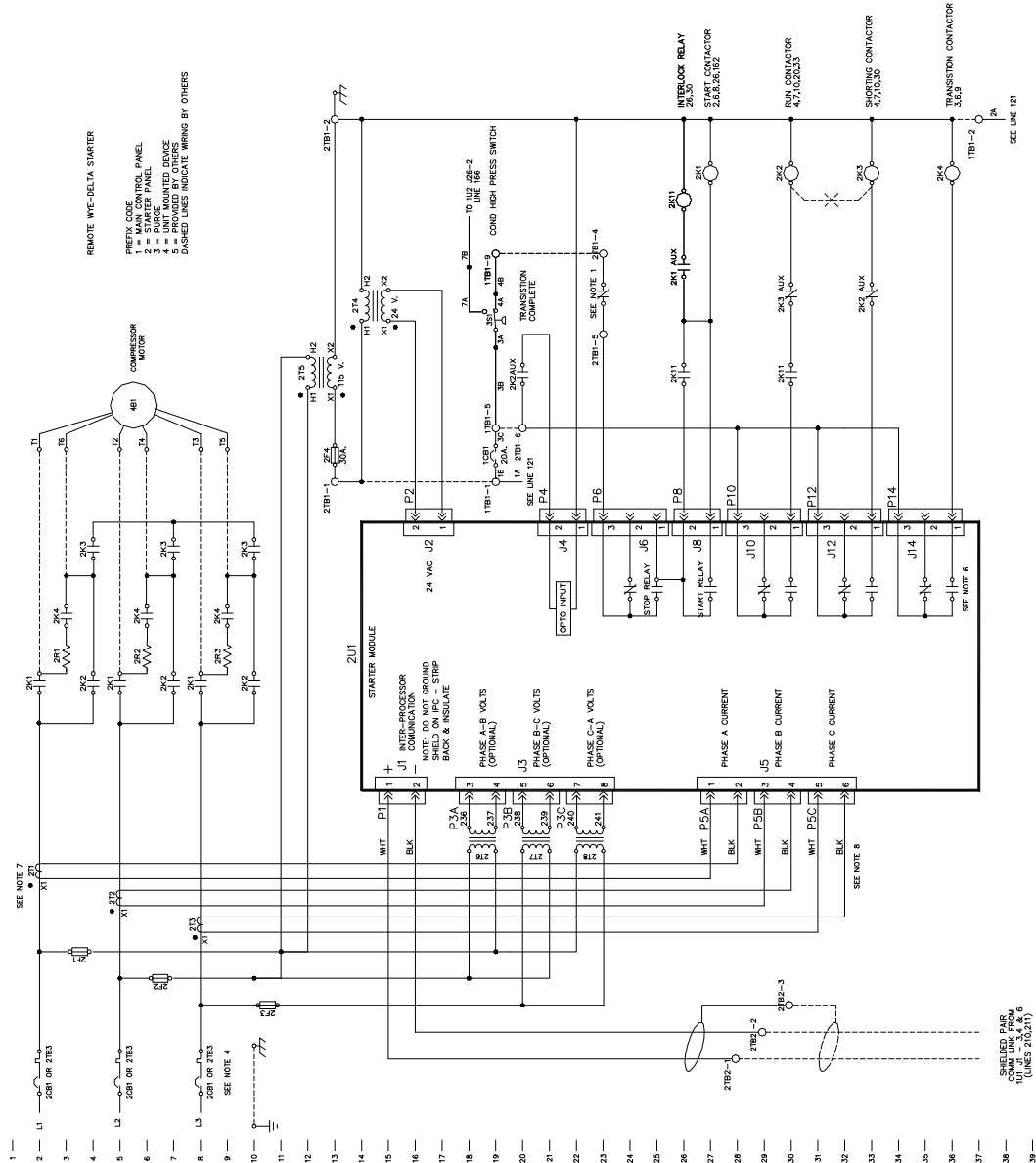

# Chiller Controls System

Figure 17 - Trane Supplied Remote Mounted Wye-Delta Starter

2307-5204 A

CentraVac Sequence of Operation With WYE-DELTA Starter

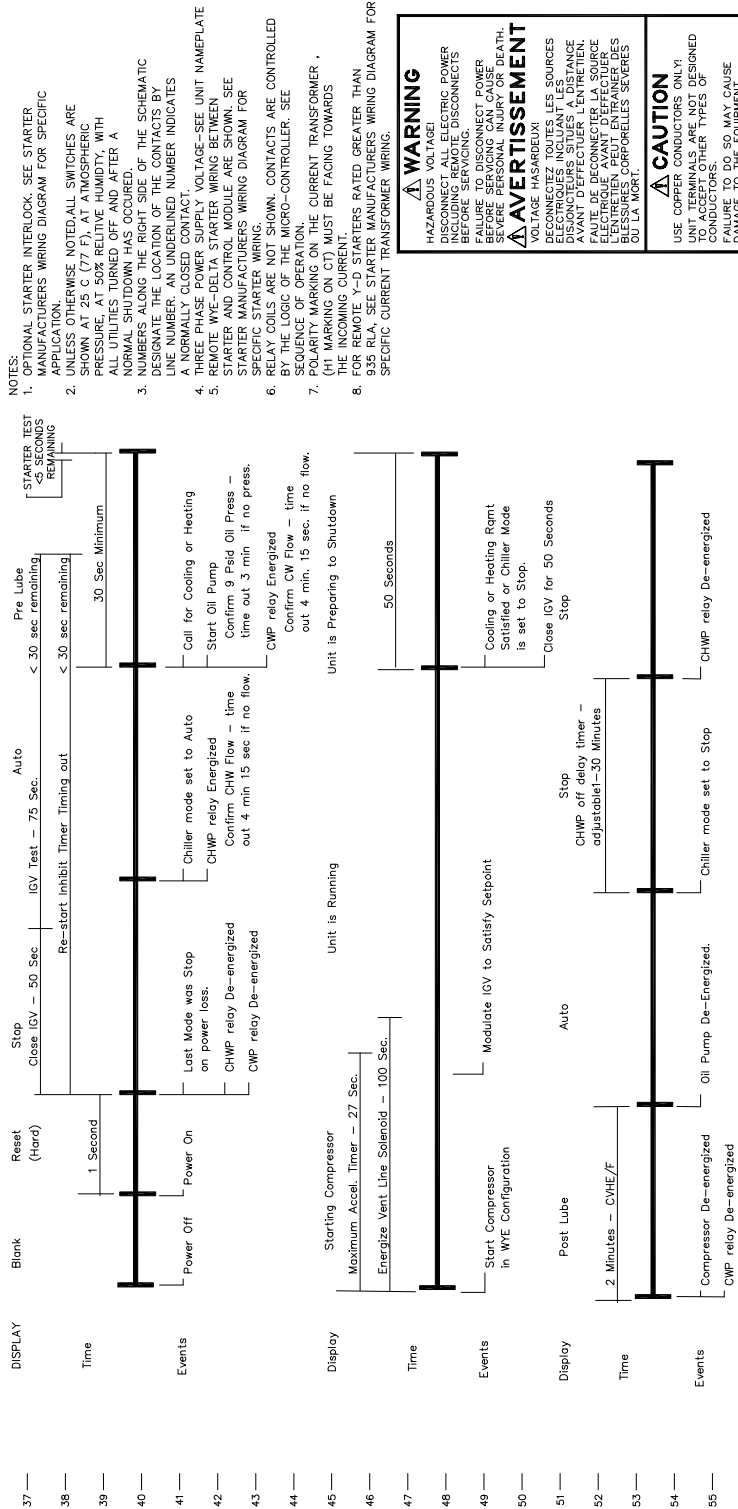

- NOTES:
- OPTIONAL STARTER INTERLOCK. SEE STARTER MANUFACTURERS WIRING DIAGRAM FOR SPECIFIC APPLICATION.
  - UNLESS OTHERWISE NOTED, ALL SWITCHES ARE SHOWN AT 25 C (77 F), AT ATMOSPHERIC PRESSURE. ALL UTILITIES TURNED OFF AND AFTER A NORMAL SHUTDOWN HAS OCCURRED.
  - NUMBERS ALONG THE RIGHT SIDE OF THE SCHEMATIC DESIGNATE THE LOCATION OF THE CONTACTS BY LINE NUMBER. AN UNDERLINED NUMBER INDICATES A NORMALLY CLOSED CONTACT.
  - THREE PHASE POWER SUPPLY VOLTAGE—SEE UNIT NAMEPLATE
  - REMOTE WYE-DELTA STARTER WIRING BETWEEN STARTER MAIN CONTACTS AND CHWP WIRING SEE STARTER MANUFACTURERS WIRING DIAGRAM FOR SPECIFIC STARTER WIRING.
  - RELAY COILS ARE NOT SHOWN. CONTACTS ARE CONTROLLED BY THE LOGIC OF THE MICRO-CONTROLLER. SEE SEQUENCE OF OPERATION.
  - POLARITY MARKING ON THE CURRENT TRANSFORMER, THE INCOMING CURRENT.
  - FOR REMOTE WYE-DELTA STARTERS RATED GREATER THAN 1000 HP, SEE CHASER MANUFACTURERS WIRING DIAGRAM FOR SPECIFIC CURRENT TRANSFORMER WIRING.

**WARNING**

HAZARDOUS VOLTAGE! DISCONNECT ALL ELECTRIC POWER BEFORE SERVICING. DISCONNECT BEFORE SERVICING CAN CAUSE SEVERE ELECTRICAL SHOCK OR DEATH.

**AVERTISSEMENT**

VOLTAGE HASARDEUX! DÉCONNECTEZ TOUS LES SOURCES D'ÉLECTRICITÉ AVANT D'EFFECTUER DES TRAVAUX D'ENTRETIEN. LES BLESSURES CORPORELLES SÉRIEUSES OU LA MORT.

**CAUTION**

USE COPPER CONDUCTORS ONLY! USE COPPER CONDUCTORS DESIGNED TO ACCEPT OTHER TYPES OF CONDUCTORS. FAILURE TO DO SO MAY CAUSE DAMAGE TO THE EQUIPMENT.

# Chiller Control System

Figure 18 - Circuit Module (1U2) - CVHE, CVHF and CVHG With Refrigerant Pump

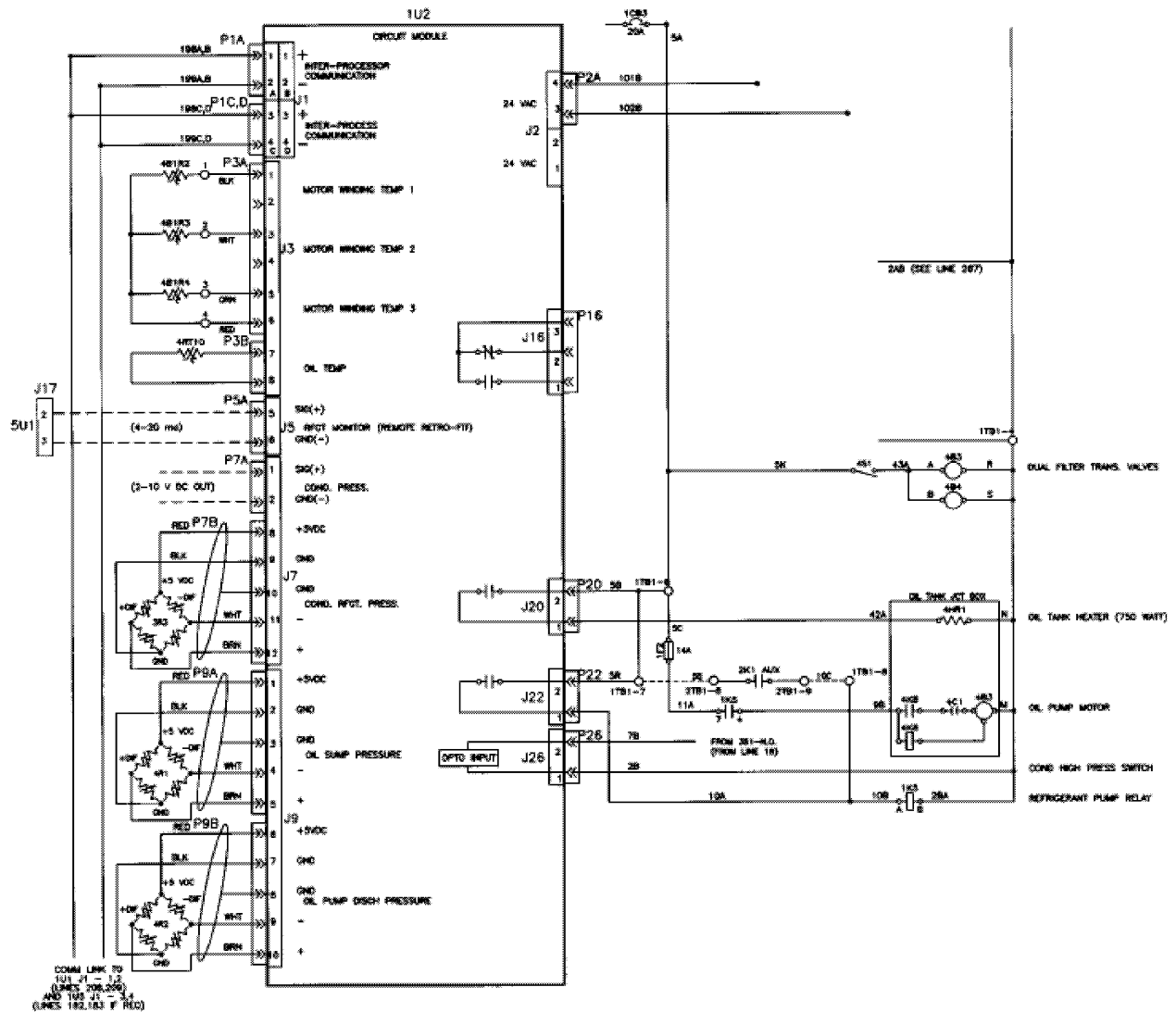

# Chiller Control System

---

## UCP2 Board Dip Switch Settings

Several of the UCP2 modules have dip switch settings on them, used to set up the board for 2-10 VDC or 4-20 MA signal inputs and or outputs of the boards. The following are the various switch settings.

### Chiller Module

External Vane Position	Switch	2-10V	4-20 MA
	SW2-1	OFF	ON (SW2-2 and SW2-3 are not used).

### Options Module

External Current Limit External Chilled Water	Switch	2-10V	4-20 MA
	SW2-1	OFF	ON (SW2-2 and SW2-3 are not used).
	SW3-1	OFF	ON (SW2-3 not used)

### TCI/IPC Modules

Tracer COM3	Switch	-1	-2	-3
	SW1	OFF	OFF	OFF

Tracer COM4	Switch	-1	-2	-3
	SW1	OFF	ON	OFF

IPC BUFFER	Switch	-1	-2	-3
	SW1	OFF	OFF	ON

PRINTER	Switch	-1	-2	-3
	SW1	OFF	OFF	ON

# Chiller Control System

## Setup for External Current Limit Setpoint

The External Current Limit is an option that allows the current limit setpoint to be changed from a remote location. The External Limit Setpoint is found on Option Module terminals J7-11 and J7-12.

UCP2 shall accept either a 2-10 Vdc or 4-20 analog input suitable for customer connection to set the unit external current limit setpoint. 2-10 vdc and 4-20 ma shall each correspond to a 40 to 120% RLA range. CTV UCP2 will limit the maximum ECLS to 100%.

The following must be "SET":

1. SW2-1-OFF for 2-20 Vdc  
On for 4-20 ma.
2. Current Limit Setpoint  
Source: External
3. External Current Limit  
Setpoint: Installed
4. Setpoint Type: 2-10 Vdc  
or 4-20 ma

The user must also specify the type of External Setpoint Input (4-20 ma or 2-10 VDC) in the Machine Configuration Menu.

## Setup for External Chilled Water Setpoint

The External Chilled Water Setpoint allows the chilled water setpoint to be changed from a remote location. The External Chilled Water Setpoint is found on Options Module terminals J9-4 and J9-5.

UCP2 shall accept either a 2-10 Vdc or 4-20 ma analog input suitable for customer connection to set the unit leaving chilled water setpoint. 2-10 vdc and 4-20 ma shall each correspond to a 0 to 65 F (-17.8 to 18.3 C) CWS range.

The following must be "SET":

1. SW3-1 OFF for 2-10 VDC.  
ON for 4-20 MA.
2. Chilled Water Reset Type:  
Disable - Operator Settings  
Group
3. Chilled Water Setpoint :  
Source External - Operator  
Settings Group
4. Setpoint Source Override:  
None - Operator Settings Group
5. External Chilled Water Setpoint:  
Installed - Service Settings  
Group - Machine Configuration
6. Setpoint Type: 2-10 Vdc or  
4-20 ma. - Service Setting  
Group-Machine Configuration

## Refrigerant Monitor Input

Analog type input 4-20ma input signal to the Circuit module J5-5 and J5-6. This represents 0-100 ppm.

Under Machine Configuration "Refrigeration Monitor Type". Direct communication to the CLD via the IPC.

Under Machine Configuration

"Refrigeration Monitor Type" " 02" for IPC Monitor.

Also allows monitor calibration and setup. Please note that the monitor cannot have a local display, and communicate with the UCP2. If the customer requires a local display, he can connect an RMWD style monitor up like the analog type previously described. See Figure 19 for the Refrigerant Monitor Module (4U1).

## Load Indication Output

Option Modules J7-3, --4

2-10 Vdc

As an option, the UCM shall provide a 0-10 Vdc analog output to indicate % RLA. The transfer function shall be 2 to 10 Vdc corresponding to 0 to 120% RLA.

## Percent RLA Output:

UCP2 provides a 2-10 Vdc analog output to indicate Percent RLA. The transfer function shall be 2 to 10 Vdc corresponding to 0 to 120% RLA. With a resolution of 0.146%.

The following graph illustrates the output:

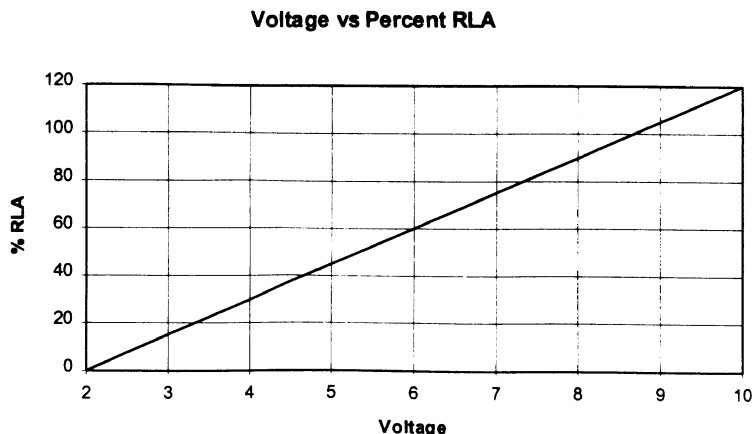

# Chiller Control System

The Percent RLA Output is found on the Options Module terminals J7-3 and J4.

The Percent RLA Output is polarity sensitive.

J7-3 is +  
J7-4 is -

The Percent RLA Output's maximum source capability is 30mA.

## Percent Condenser Pressure Output:

The transfer function is 2 to 10 Vdc corresponding to 0 Psia to the HPC setting (psig) plus the local atmospheric pressure setting or, 0 Psia to HPC in Psia. The Percent Condenser Pressure Indication Output is based on the Condenser Refrigerant Pressure sensor if the Condenser Pressure Option is selected as "installed" at the CLD. The Percent Condenser Pressure Indication Output is based on the Saturated Condenser Refrigerant Temperature sensor if the Condenser Pressure Option is selected as "Not Installed" at the CLD.

When a Temperature Sensor Only is used and a Temperature to Pressure Conversion is made:

If the Condenser Saturated Temperature goes out of range due to an open or short, a pressure sensor diagnostic will be called and the output will also go to the respective out of range value. That is, for an out of range low on the sensor, the output will be limited to 2.0 VDC. For an out of range high on the sensor, the output will be limited to 10.0 VDC.

When a Condenser Pressure Sensor is used (Optional): If the Condenser Pressure sensor goes out of range due to an open or short, a pressure sensor diagnostic

will be called and the output will go to end of range low. That is, for an out of range low on the sensor, the output will be limited to 2.0 VDC. For an out of range high on the sensor, the output will be limited to 2.0 VDC.

When a Temperature Sensor Only is used (Optional): If the Temperature Sensor (or Condenser Pressure sensor) goes out of range due to an open or short, a Temperature Sensor (or Pressure Sensor) diagnostic will be called and the output will go to end of range low. That is, for an out of range low on the sensor, the output will be limited to 2.0 VDC. For an out of range high on the sensor, the output will be limited to 2.0 VDC.

Or:

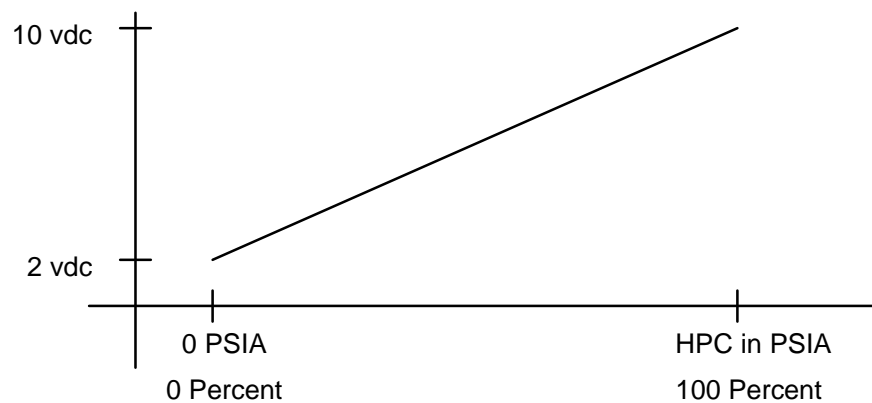

## Refrigerant Differential Pressure Indication Output:

(Selectable in Service Settings - Field Start-up Group) The Transfer function is 2 to 10 VDC corresponding to the menu entered "Min Delta Pressure Calibration" setting to the menu entered "Max Delta Pressure Calibration" setting.

# Chiller Control System

The transfer function is 2 to 10 Vdc corresponding to the menu entered "Min Delta Pressure Calibration" setting to the menu entered "Max Delta Pressure Calibration" setting. The Min Delta Pressure Calibration setting shall have a range of 0-400 psid (0-2758 kPa) in increments of 1 psid (1kPa).

The Max Delta Pressure Calibration setting shall have a range of 1-400 psid (7-2758 kPa) in increments of 1 psid (1kPa). The condenser refrigerant pressure shall be based on the Condenser Refrigerant Temperature sensor if the Condenser Pressure Option is selected as "Not Installed" at the CLD.

The evaporator refrigerant pressure shall be based on the Saturated Evaporator Refrigerant Temperature Sensor.

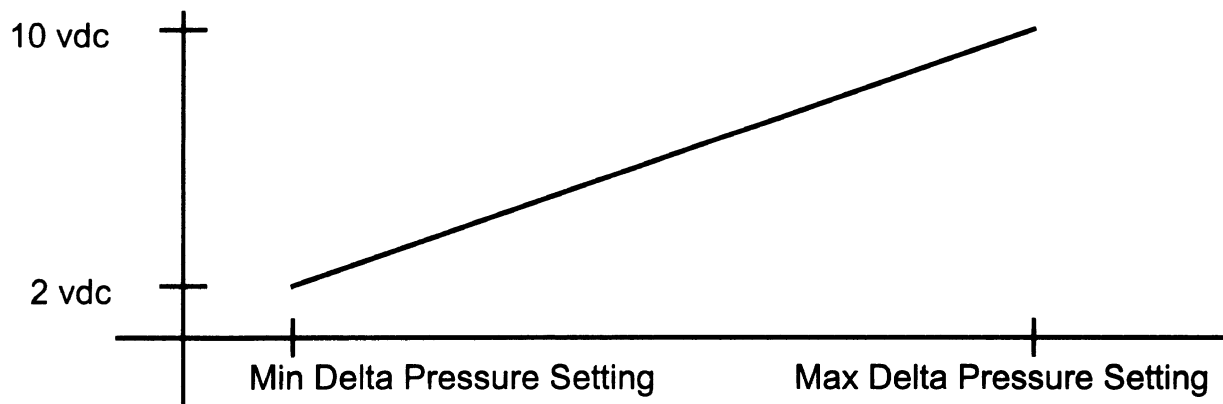

The Percent Condenser Pressure/Refrigerant Differential Pressure Indication Output is located on the Circuit Module at J7-1, 2.

If the saturated condenser temperature is used to determine condenser pressure, it takes about 11.5 seconds for UCP2's Percent Condenser Pressure Output to respond to a step change in saturated condenser temperature.

The Percent Condenser Pressure Output can source a maximum of 30mA of current.

The maximum recommended length to run this signal is included in Table 1.

**Table 1 - Recommended Length to Run Percent Condenser Pressure Output**

Gauge	Ohms/Foot	Max Length (Ft)	Max Length (M)
14	0.002823	1062.7	324.0
16	0.004489	668.3	203.8
18	0.007138	420.3	128.1
20	0.01135	264.3	80.6
22	0.01805	166.3	50.7
24	0.0287	104.5	31.9
26	0.04563	65.7	20.0
28	0.07255	41.4	12.6

Note: the above table is for copper conductors only.

# Chiller Control System

Figure 19 - Refrigerant Monitor (4U1) CVHE, CVHF and CVHG

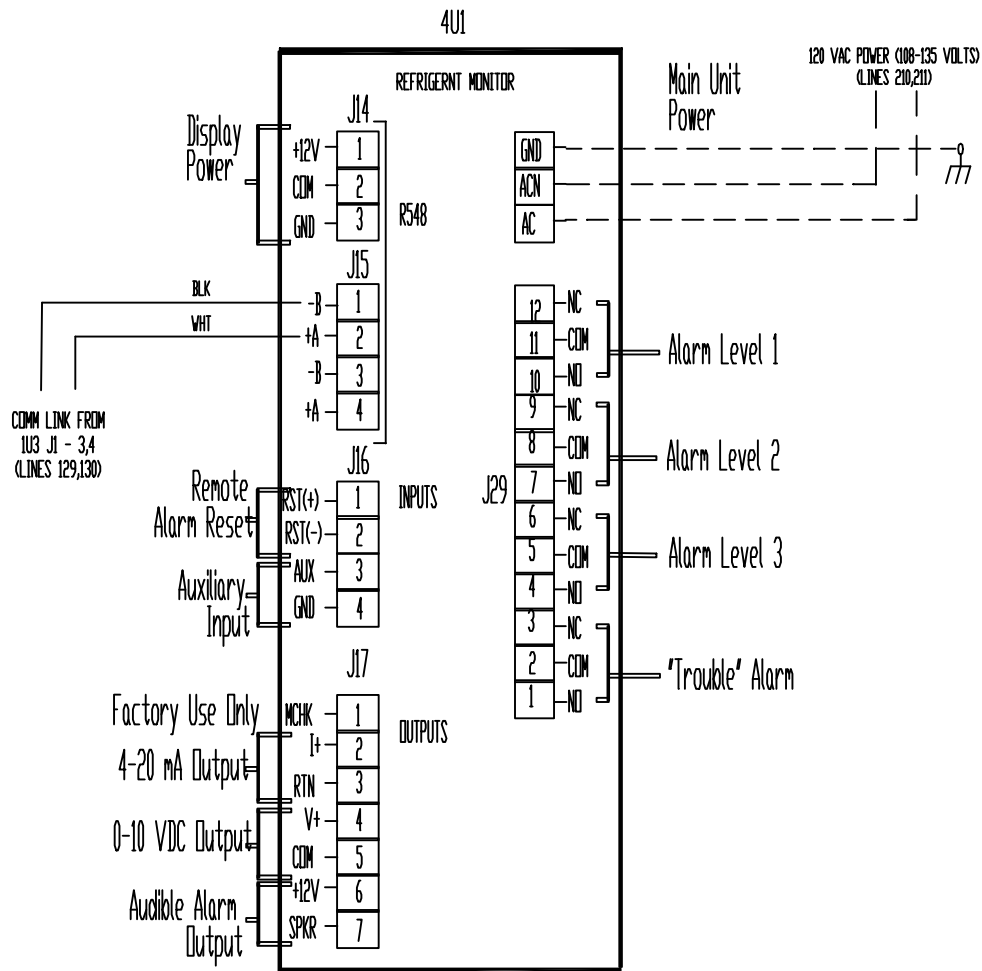

# Electrical Sequence of Operation

---

## Overview

This section will acquaint the operator with the control logic governing CVHE, CVHF and CVHG chillers equipped with UCP2 based control systems. When reviewing the step-by-step electrical sequences of operation, refer to the typical wiring schematics shown in the installation manual or wiring manual which are shipped with the chiller.

**Note:** The typical wiring diagrams are representative of standard units and are provided only for general reference. They may not reflect the actual wiring of your unit. For specific electrical schematic and connection information, always refer to the wiring diagrams that shipped with the chiller.

With the supply power disconnect switch or circuit breaker (2CB1) closed, 120-volt control power transformer 2T5 and a 30-amp starter panel fuse (2F4) to terminal 1TB1-1 in the UCP2 control panel. From this point, control voltage flows to:

**Circuit Breaker 1CB1**, supplying power to starter module (2U1) via terminal 2TB1-6 for starter contactors operation and the high condenser pressure switch 3S1.

**Circuit Breaker 1CB2**, supplying power to the purge module (3U1) and the 24 volt supply transformer 3T1 for the purge module (3U1).

**Circuit Breaker 1CB3**, Supplying power to:

1. The I/O module (1U10) will operate the Hot Gas Bypass valve, the Oil Heater (4R1), and the oil pump motor through Fuse 1F2.
2. The chiller module (1U1) will operate evaporator (4L2) and condenser (4L3) water pressure

transducer solenoids and to the chilled water (5S1) and condenser water (5S2) flow switch circuits.

The starter module (2U1) receives 24 volt power from control power transformer 2T4 in the starter panel.

The Clear Language Display (1U4), Stepper (1U3), Circuit (1U2), Options (1U5), Chiller (1U1), and COMM (1U6), (1U7), (1U8) & (U10) modules obtain 24 volt power from control power transformer 1T1 in the control panel.

## Chilled and Condenser Water Flow Interlock Circuits

Proof of chilled water flow for the evaporator is made by the closure of flow switch 5S1 and the closure of auxiliary contacts 5K1 on terminals 1TB1-11 and 1TB1-12.

Proof of condenser water flow for the condenser is made by the closure of flow switch 5S2 and the closure of auxiliary contacts 5K2 on terminals 1TB1-11 and 1TB1-13.

## UCP2 and Wye-Delta Starter Control Circuits

Logic Circuits within the various modules will determine the starting, running, and stopping operation of the chiller. If operation of the chiller is required and the chiller mode is set at "Auto", then the Chiller Module's logic decides to start the chiller based on the differential to start setpoint.

The chiller water pump relay (5K1) is energized by the Chiller Module (1U1-J12) and chilled water flow must be verified within 3 minutes by the Chiller Module (1U1-J26).

Circuit Module (1U2-J22) and the condenser water pump relay (5K2) Based on the restart inhibit timer and the differential to start setpoint,

oil pump and refrigerant pump (4B3) will be energized by the will be energized by the Chiller Module (1U2-J14) when the restart inhibit timer is at 30 seconds or less. The oil pressure must be at least 9 Psid for 30 continuous seconds and condenser water flow verified within 3 minutes by the Chiller Module (1U1-J28) for the compressor start sequence to be initiated.

When less than 5 seconds remain before compressor start, a starter test is conducted to verify contactor states prior to starting the compressor. The following test/start sequence is conducted for "Wye-Delta" starters: Also refer to Figure 21 in this manual.

A. Test for transition complete contact open (2K2 AUX at 2U1-J4) - 160 to 240 msec. An MMR diagnostic will be generated if the contact is closed.

B. Delay time - 20 msec.

C. Close start contactor (2K1) and check for no current - 500 msec. If currents are detected, the MMR diagnostic "Starter Fault Type I" is generated.

D. Stop relay (2U1-J6) closes for 1 second for test "C" above.

E. Delay time - 200 msec.(Opens 2K1).

F. Close shorting contactor, (2K3) and check for no current - 1 sec. If currents are detected the MMR diagnostic "Starter Fault Type II" is generated. (Starter Integrity test)

# Electrical Sequence of Operation

---

G. If no diagnostics are generated in the above tests, the Stop Relay (2U1-J6) is closed for 2 seconds and the Start Relay (2U1-J8) is closed to energize the start contactor (2K1). The shorting contactor (2K3) has already been energized from (F) above. The compressor motor (4B1) starts in the “Wye” configuration, an auxiliary contact (2K1-AUX) locks in the start contactor (2K1) coil.

H. After the compressor motor has accelerated and the maximum phase current has dropped below 85% of the chiller nameplate RLA for 1.5 seconds, the starter transition to the “Delta” configuration is initiated.

J. The transition contactor (2K4) is closed through relay 2U1-J14, placing the transition resistors (2R1, 2R2, and 2R3) in parallel with the compressor motor windings.

K. The shorting contactor (2K3) is opened through the opening of relay 2U1-J12 100 msec after the closure of the transition relay 2U1-J14.

L. The run contactor (2K2) is closed through relay 2U1-J10 shorting out the transition resistors 260 msec after the opening of the shorting relay 2U1-J12. This places the compressor motor in the “Delta” configuration and the micro waits to look for this transition for 2.35 seconds through the closure of the transition complete contacts (2K2-AUX) at 2U1-J4.

M. The micro must now confirm closure of the transition complete contact (2K2-AUX) within 2.32 to 2.38 seconds after the run relay (2U1-J10) is closed. Finally, the transition relay (2U1-J14) is opened de-energizing the transition contactor (2K4) and the compressor motor starting sequence is complete. An MMR diagnostic will be generated if the transition complete contacts (2K2-AUX) do not close. A diagram of this test/start sequence is shown in Figure 21.

Now that the compressor motor (4B1) is running in the “Delta” configuration, the inlet guide vanes will modulate, opening and closing to the chiller load variation by operation of the stepper vane motor actuator (4B2) to satisfy chilled water setpoint. The chiller continues to run in its appropriate mode of operation: Normal, Softload, Limit Mode, etc.

If the chilled water temperature drops below the chilled water set point by an amount set as the “differential to stop” setpoint, a normal chiller stop sequence is initiated as follows:

1. The inlet guide vanes are driven closed for 50 seconds.
2. After the 50 seconds has elapsed, the stop relay (2U1-J6) and the condenser water pump relays (1U1-J14) open to turn off the compressor motor (4B3) will continue to run for 2 minutes post lube while the compressor coasts to a stop. The chilled water pump will continue to run while the chiller module (1U1) monitors leaving chilled water temperature preparing for the next compressor motor start based on the “differential to start” setpoint.

If the STOP key is pressed on the human interface, the chiller will follow the same stop sequence as above except the chilled water pump relay (1U1-J12) will also open and stop the chilled water pump after the chilled water pump delay timer has timed out after compressor shut down.

If the STOP key is pressed twice in rapid succession, twice within 5 seconds, a “panic stop” is initiated which follows the same stop sequence as pressing the STOP key once except the inlet guide vanes are not sequence closed and the compressor motor is immediately turned off.

## Vane Actuator Control

The 1U3 Stepper Module pulses a DC voltage to the windings of the 4B2 Stepper Module Vane Actuator and 4B4 for CVHF 1470 and 1720 to control inlet guide vane position.

While operation of this stepper motor is automatic, manual control is possible by going to the Vane Control Status/Vane Position Commands screen in the Service Tests Menu and changing the “Target” value.

**Note:** If the chiller is operating in a limit mode (i.e. current limit, condenser limit, evaporator limit, etc.) the limit operation has priority over all manual modes of operation.

On each UCP power-up, the inlet guide vanes are driven full closed to recalibrate the zero position (Steps) of the Stepper motor vane actuator. An inlet guide vane stroke test is conducted for BPI (Binary Position Indicator) position on all resets (hardware and software) if there has not been a Momentary Power Loss.

# Electrical Sequence of Operation

**Figure 21**  
**UCP2 Test/Start Timing Sequence**

Timing requirements to operate the "Stop", "Start", "Short", "Transition", and "Run" contact closure outputs are shown below. Prior to closing the "Short" contact, the transition complete input shall be verified to be open, otherwise an MMR diagnostic shall be generated.

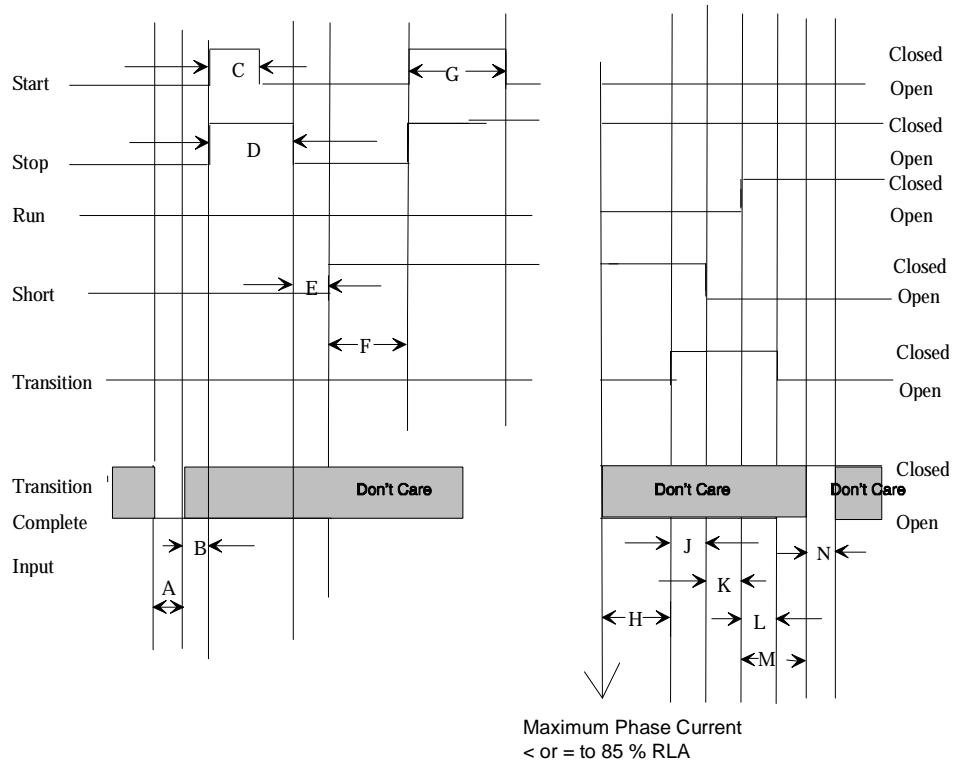

Interval	Minimum	Maximum	Units	Actual Design
A (Test for transition complete input open)				160 to 240 msec
B (Just delay time)				20 msec
C (Close 1M (2K1) Contactor and test for no current.)(Starter integrity test)				500 msec
D-(Hold 1M (2K1) Contactor and test for no current.)(Starter integrity test)				1 sec
E- (Open 1M (2K1) Delay time				200 msec
F- (Close Shorting Contactor (2K3) and test for no current, then wait for Start command.) (Starter integrity test)	100 (1)		msec	1 sec (Min)
G (Close 1M (2K1)	2.0		sec	2 sec
H- (Wait 1.5 sec after phase currents drop to 85%)	1	2	sec	1.5 sec
J - (Begin Transition sequence)	85	100	msec	100 msec
K- (Open S (Shorting) Contactor)	250	300	msec	260 msec
L- (Close 2M (2K2) Contactor				140 msec
M- (Wait to look for Transition complete)	(2)		msec	2.32 to 2.38 sec
N (Filtering time on Transition complete input)	(2)		msec	160 to 240 msec

# Electrical Sequence of Operation

---

This is also done if there is a call for cooling or heating condition and it has been 24 hours or more since the last BPI test and there has not been a Momentary Power Loss for 5 minutes. See Figure 22 for BPI operation.

**Note:** The closed range of the BPI must straddle the factory programmed 90 degree Vane Position.

## Circuit Breaker 1CB3 Oil Pump and Refrigerant/Oil Pump

Circuit Breaker 1CB3 115-volt control power from control power transformer 2T5 flows through branch circuit breaker 1CB3 and terminal 1TB1-6 to a 15 amp fuse (1F2) Fuse which protects the refrigerant/oil pump motor (4B3) from over amperage conditions.

**Figure 22**  
CVHE, CVHF, CVHG IGV/Actuator Operation and BPI Switch

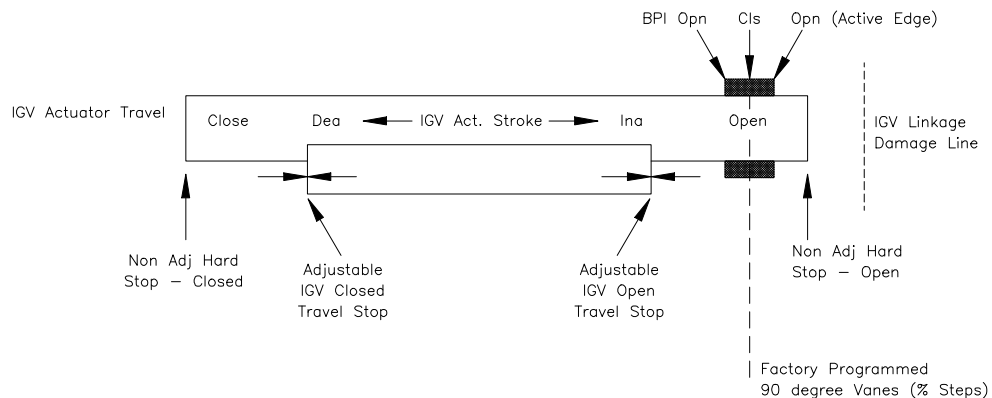

# Electrical Sequence of Operation

Current passing through fuse 1F2 reaches 3 normally open parallel sets of contacts: those of refrigerant/oil pump relay (1K5), 1U2-J22 relay and the start contactor 2K1-aux.

**Note:** While the 1U2-J22 relay automatically is closed by 1U2 as a part of the start sequence. It can also be closed manually by changing the oil pump status to "ON" in the service test mode.

Closure of the 1U2-J22 or 2k1 auxiliary contacts also allows current to pass through the coil of the refrigerant pump starter relay (1K5) closing the contact 1K5, to the start windings of the refrigerant pump. When motor 4B3 first starts, current draw is high: This causes current sensing relay 4K8 to close its normally open contacts and pull in of pump Capacitor 4C1. Increasing motor speed and related decreasing current through the main winding and relay coil reduce the magnetic force and the armature "Drips out". To open the start contacts and disconnect the start windings and capacitor. Current now flows to the Run windings of the oil pump motor or refrigerant/oil pump motor.

## Restart Inhibit

A Restart Inhibit Timer is used to prevent high frequent chiller ON-OFF cycling and subsequent motor overheating.

The Restart Inhibit (RI) timer is set based on a Background Timer (BT) that is incremented by (XX) minutes at every start and is timed out from the new total only while the chiller is running and is based on the equation:  $RI = BT - 50$ .

The value of XX is based on nominal compressor size to include the motor heating constant as listed in the Table 2 on this page.

This value of the motor heating constant (XX) must be set in the Machine Configuration Group of the Service Settings Menu based on the unit NTON and motor frequency.

On any UCM Reset (either hardware (e.g. powerup or software), the RI Timer is reset to 30 seconds if the motor winding temperature is less than or equal to 165°F. The maximum value of the RI Timer is 60 minutes, and is adjustable from 25 to 60 minutes in the Field Startup Group of the Service Settings menu.

See Figure 23 for an example of how the RI Timer functions.

Any other pre-start system timers, e.g. prelube = 60 seconds, overlap the RI Timer to anticipate its time out and permit start of the compressor at or shortly after the RI. If the RI Timer value ever reaches 45 minutes an IFW diagnostic is generated.

The RI Timer can be cleared to 30 seconds in the Service Settings Menu.

If the RI Timer is the overriding criteria holding the chiller off, this mode will be displayed along with the remaining time, counting down, prior to the chiller starting.

NTON	BT
230-320	30
360-500	35
560-800	40
890 - 1280	50
1470-1720	65

# Electrical Sequence of Operation

---

**Figure 23**  
CVHE, CVHF and CVHG - UCP2 Restart Inhibit Timer

Parameter	CVHE/CVHF
Background Timer Increment on Start (Motor Heating Constant)	Adjustable, 25 Min. Fac. Dfft.
General RI Timer Setting	RI = BT -50 Minutes
Minimum RI Timer Setting	30 Seconds
Maximum RI Timer Setting	60 Minutes
Adjustment Range of Maximum RI Timer Setting	30 to 60 Minutes
Winding Temperature Decision Point/RI Timer Above this Temp. after Reset	165 F (73.8C)/15 Minutes
IFW Diagnostic Threshold	RI Timer = 45 Minutes

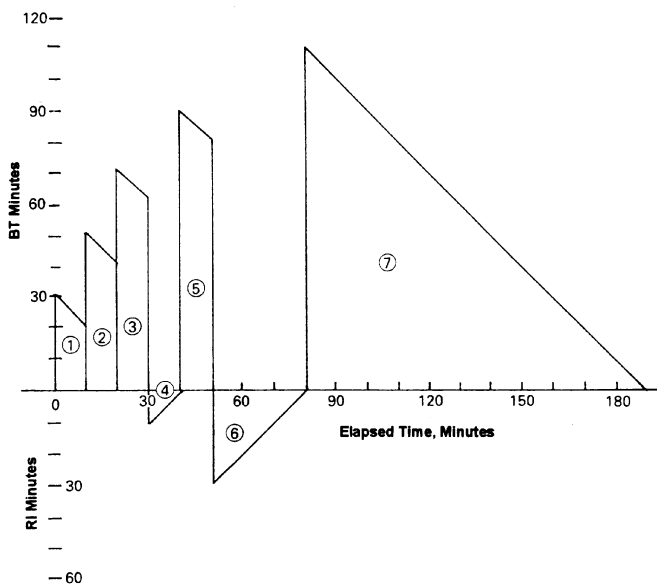

1. Unit started and ran 10 min., BT incremented 30 Min., and decreased by 10 min. RI = (30-10) - 50 = -30.
2. Unit restarted RI = -30, BT incremented another 30 min., unit ran 10 min. and BT decreased by 10 min. RI = (50-10) - 50 = -10
3. Unit restarted RI = -10, BT incremented another 30 min., unit ran 10 min. and BT decreased by 10 min., RI = (70-10) - 50 = 10.
4. Unit Restart Inhibit is 10 min. from (3).
5. Unit restarted after 10 min. RI in (4), BT incremented another 30 min., unit ran 10 min. and BT decreased by 10 min. RI = (90-10) - 50 = 30.
6. Unit restart is 30 min. from (5).
7. Unit restarted after 30 minute RI min, (6), BT incremented another 30 min., and unit ran for 110 min., and BT goes to zero.

**Notes:**

1. 30 second/15 minute restart inhibit due to motor winding temperature not included.
2. Example for Motor Heating Constant = 30
3. If calculated RI is negative then RI = 0.

# Electrical Sequence of Operation

---

## Controls Chilled Water Reset (CWR)

Chilled water reset is designed for those applications where the design chilled water temperature is not required at partload. In these cases, the leaving chilled water temperature setpoint can be reset upward using the CWR features.

When the CWR function is based on return water temperature, the CWR feature is standard.

When the CWR function is based on outdoor air temperature, the CWR feature is an option requiring an outdoor temperature sensor and the Options Module installed in the UCP2 panel.

The type of CWR is selected in the Operator settings Menu along with the Reset Ratio, Start Reset Setpoint, and the Max Reset Setpoint.

The following equations and parameters apply for CWR.

## Return Water

$CWS' = CWS + RATIO (START\ RESET - TWE - TWL)$  and  $CWS' > or = CWS'$  and  $CWS - CWS < or =$  Maximum Reset.

## Outdoor Air Temperature

$CWS' = CWS + RATIO (START\ RESET - TOD)$  and  $CWS' > or = CWS'$  and  $CWS - CWS < or =$  Maximum Reset.

## Where

CWS is the new chilled water setpoint.

CWS is the active chilled water setpoint before any reset has occurred RESET RATIO is a user adjustable gain.

START RESET is a user adjustable reference.

TWE is entering evap. water temperature.

MAXIMUM RESET is a user adjustable limit providing the maximum amount of reset. For all types of reset,  $CWS - CWS < or =$  Maximum Reset.

The values for "Start Reset" for each of the reset types are shown in Table 3.

Both Return and Outdoor Reset do not apply to Heat Pump Mode where the UCP2 is controlling the Leaving Water Temperature.

Constant Return Reset will reset the leaving water temperature setpoint so as to provide a constant entering water temperature. The Constant Return Reset equation is the same as the Return Reset equation except on selection of Constant Return Reset, the UCP2 shall automatically set RATIO, START RESET, and MAXIMUM RESET to the following:

The RATIO = 100%  
The START RESET = Design Delta Temp.  
The MAXIMUM RESET = Design Delta Temp.

The equation for Constant Return is as follows:

**Table 3 - Values for Start Reset Types**

The values for "RESET RATIO" for each of the reset types are:				
Reset Type	Reset Ratio Range	Increment English Units	Increment SI Units	Factory Default Value
Return	10 to 120%	1%	1%	50%
Outdoor	80 to -80%	1%	1%	10%
The values for "START RESET " for each of the reset types are:				
Reset Type	Start Reset Range	Increment English Units	Increment SI Units	Factory Default Value
Return	4 to 30 F (2.2 to 16.7C)	1 F 1 F	0.1 C 0.1 C	10 F (5.6C) 90 F (32.2C)
The values for "MAXIMUM RESET" for each of the reset types are:				
Reset Type	Maximum Reset Range	Increment English Units	Increment SI Units	Factory Default Value

# Electrical Sequence of Operation

---

## Constant Return

$CWS' = CWS + 100%$   
 (Design Delta Temp.) - (TWE-TWL)  
 and  $CWS \geq CWS$  and  $CWS -$   
 $CWS \leq$  Maximum Reset

Notice that Constant Return is nothing more than a specific case of Return Reset offered for operator convenience.

When any type of CWR is enabled, the UCP2 will step the CWS toward the desired CWS (based on the above equations and setup parameters) at a rate of 1°F every 5 minute until the Active CWS equals the desired CWS'. This applies when the chiller is both running and not running.

The chiller will start at the Differential to Start value above a fully reset CWS or CWS for both Return and Outdoor Reset.

The graph on the next page, shows the reset function for Outdoor Air Temp: **Note:** This graph assumes that Maximum Reset is set to 20 degrees.

## Using the Equation for calculating CWR for Outdoor Air Temp

Equation:

$$\text{Degrees of Reset} = \text{Reset Ratio} * (\text{Start Reset} - \text{TOD})$$

### Degrees of Reset:

Degrees of Reset = Active CWS - Front Panel CWS

or

Degrees of Reset = CWS' - CWS

To obtain Active CWS from Degrees of Reset :

$$\text{Active CWS} = \text{Degrees of Reset} + \text{Front Panel CWS}$$

### Reset Ratio:

The Reset Ratio on the CLD is displayed as a percentage. To use it in the above equation it must be converted to it's decimal form.

Reset Ratio percent /100 = Reset Ratio decimal

Example of converting Reset Ratio:

If the Reset Ratio displayed on the CLD is 50% then use (50/100)=.5 in the equation

**TOD** = Outdoor Air Temp

**Start Reset** = Outdoor Air Start Reset

Example of Calculating Reset for Outdoor Air Temp:

If:

Reset Ratio = 35%

Start Reset = 80

TOD = 65

Maximum Reset = 10.5

How many Degrees of Reset will there be?

Degrees of Reset = Reset Ratio\*(Start Reset - TOD)

Degrees of Reset = .35\*(80-65)

Degrees of Reset = 5.25

If:

Reset Ratio = -70%

Start Reset = 90

TOD = 100

Maximum Reset = 17

How many Degrees of Reset will there be?

Degrees of Reset = Reset Ratio\*(Start Reset - TOD)

Degrees of Reset = -.7\*(90-100)

Degrees of Reset = 7

# Electrical Sequence of Operation

---

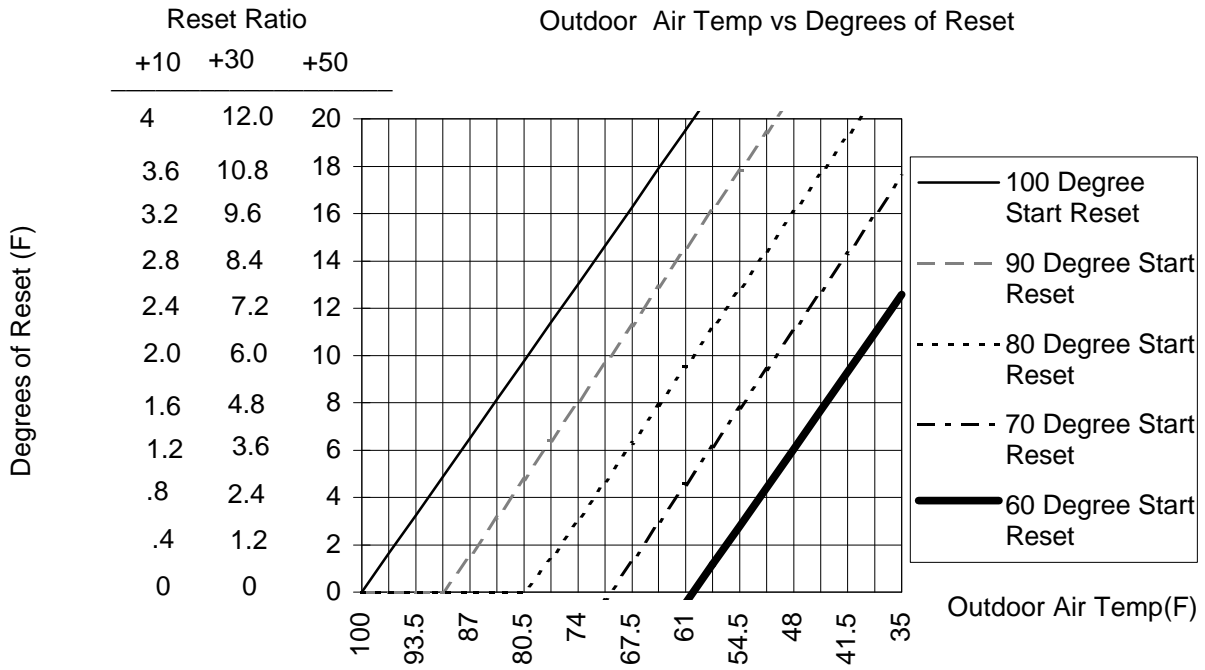

The following graph illustrates the reset functions of the above examples:

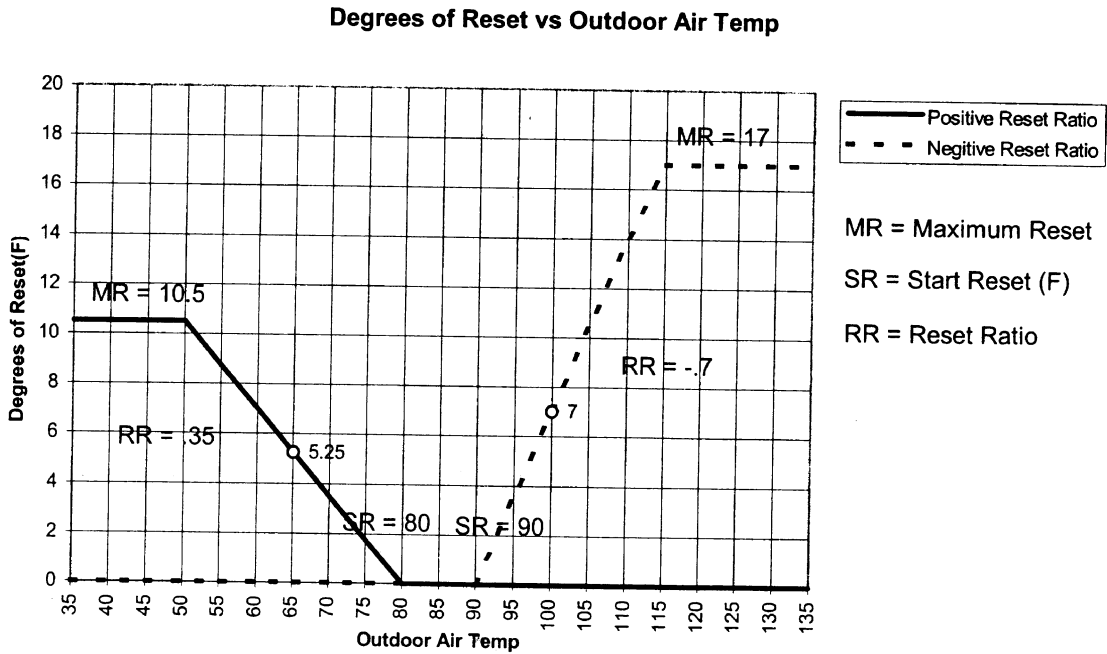

# Electrical Sequence of Operation

---

The following graph shows the reset function for Return CWR:

The following graph shows the reset function for Return CWR:

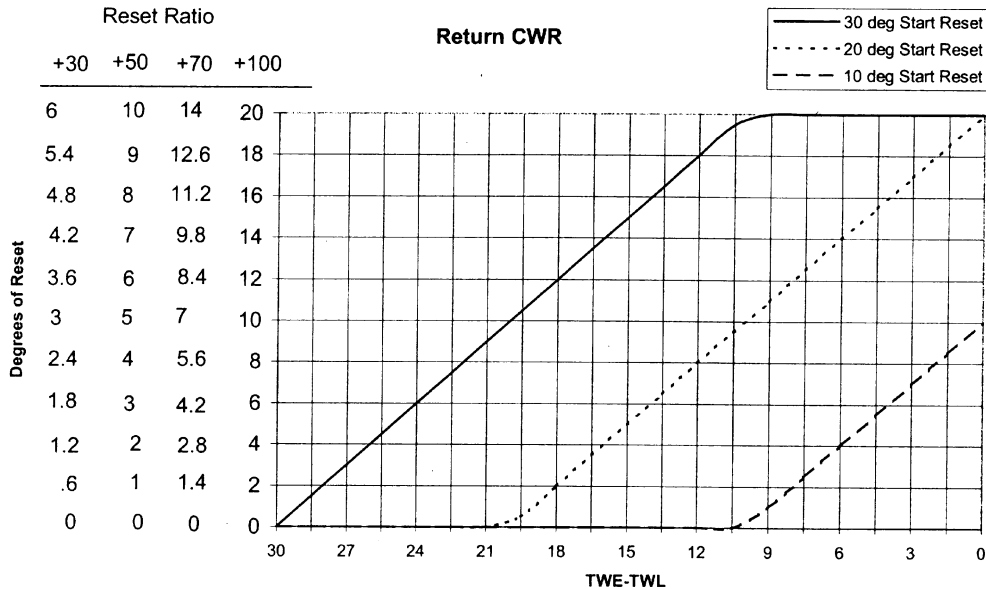

Note: This graph assumes Maximum Reset is set to 20 degrees.

Example of Calculating Return Reset:

If:  
 Reset Ratio = 50%  
 Start Reset = 25  
 TWE = 65  
 TWL = 45  
 Maximum Reset = 8

How many Degrees of Reset will there be?

Degrees of Reset = Reset Ratio\*(Start Reset - (TWE-TWL))  
 Degrees of Reset = .5\*(25-(65-45))  
 Degrees of Reset = 2.5

If:  
 Reset Ratio = 70%  
 Start Reset = 20  
 TWE = 60  
 TWL = 53  
 Maximum Reset = 14

How many Degrees of Reset will there be?

Degrees of Reset = Reset Ratio\*(Start Reset - (TWE-TWL))  
 Degrees of Reset = .7\*(20-(60-53))  
 Degrees of Reset = 9.1

# Electrical Sequence of Operation

---

Return CWR

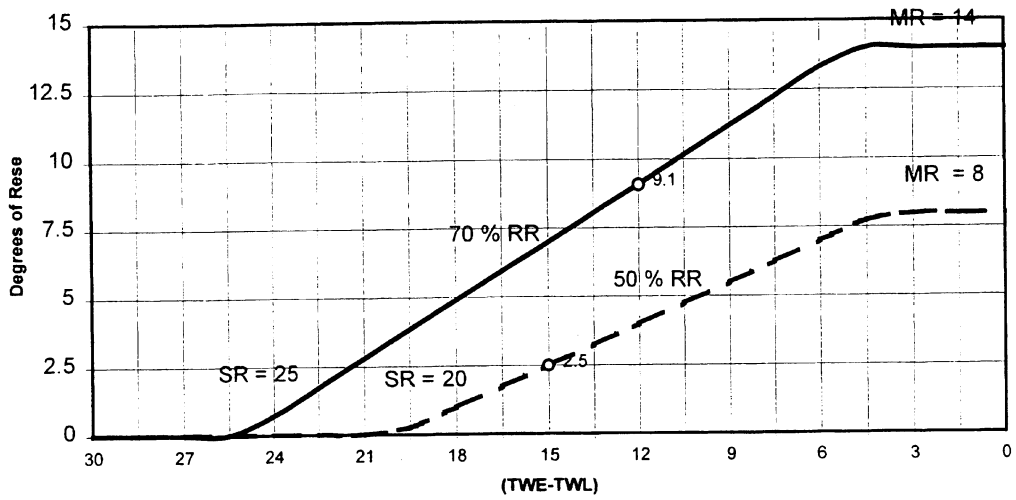

Constant CWR

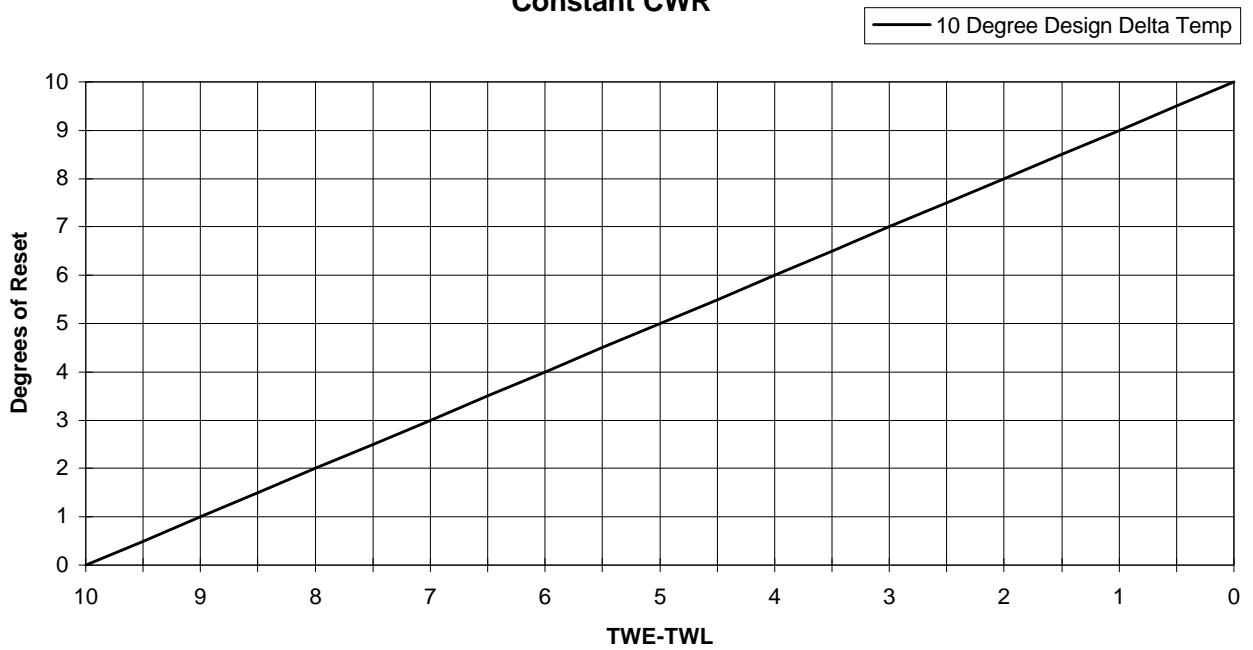

The following graph illustrates the Reset Actions of the above examples:

# Electrical Sequence of Operation

---

## Differential to Start/Stop

The Differential to Start setpoint is adjustable from 1 to 10°F (0.5 to 5.55 C) and the Differential to Stop setpoint adjustable from 1 to 10°F (0.5 to 5.55C). Both setpoints are with respect to the Active Chilled Water Setpoint and are set in the Service Settings menu.

When the chiller is running and the LWT reaches the Differential to Stop setpoint the chiller will go through its shutdown sequence to AUTO.

## Leaving Water Temperature Cutout

Leaving water temperature cutout is a safety control that protects the chiller from damage caused by water freezing in the evaporator. The cutout setpoint is adjustable in the Service Settings Menu.

For freeze protection from low leaving water temperatures the UCP2 provides a low leaving water temperature cutout based on leaving water temperature. The "Leaving Water Temperature Cutout Setpoint" is independently adjustable from the chilled water setpoint and factory set. Shutdown of the compressor due to violation of the Leaving Water Temperature Cutout results in an automatically resettable diagnostic (MAR).

The UCP2 indicates when the "Leaving Water Temperature Cutout Setpoint" conflicts with the chilled water temperature setpoint by a message on the display. The "Leaving Water Temperature Cutout Setpoint" and chilled water setpoint, both active and front panel, are separated by a minimum of 1.7°F.

See Cutout Strategy, Figure 24. When either difference is violated, the UCP2 does not permit the above differences to be violated and the display exhibits a message to that effect and remains at the last valid setpoint.

When the chilled water setpoint, both active and front panel, is adjusted downward, it does not violate the above minimum differences and the "Leaving Water Temperature Cutout Setpoint" remains at its current setting. When the "Leaving Water Temperature Cutout Setpoint" is adjusted upward, the above minimum difference is not violated and as the "Leaving Water Temperature Cutout Setpoint" is setpoint, both active and front panel, is raised to maintain the minimum difference.

After violation of the "Leaving Water Temp. Cutout Setpoint" for 30°F seconds the chiller will shutdown and indicate a diagnostic.

## Low Refrigerant Temperature Cutout

This is a safety function that prevents water in the evaporator from freezing due to low evaporator refrigerant temperatures. When the trip point is violated, the chiller will shut down and display a latching diagnostic (MMR) indicating the violation. The cutout setpoint is adjustable in the Service Settings Menu.

The UCP2 indicates when the "Low Refrigerant Temp. Cutout Setpoint" conflicts with the chilled water temperature setpoint by a message on the display.

The "Low refrigerant Temp Cutout Setpoint" and chilled water setpoint, both active and front panel, are separated by a minimum of 6°F. See Figure 24.

When either difference is violated, the UCP2 does not permit the above differences to be violated and the display exhibits a message to that effect and remains at the last valid setpoint.

When the chilled water setpoint, both active and front panel, is adjusted downward, it does not violate the above minimum differences, and the "Low Refrigerant Temperature Cutout

Setpoint is adjusted upward, the above minimum difference is not violated, and as the "Low Refrigerant Temperature Cutout Setpoint" is adjusted upward, the chilled water setpoint, both active and front panel, are raised to maintain the minimum difference.

After violation of the "Low Refrigerant Temp. Cutout Setpoint" for 30°F - seconds, the chiller will shutdown and indicate a diagnostic.

## Enhanced Condenser Limit Control

When the chiller is running Condenser Limit Mode or in Surge Mode, the head relief request relay on the Options Module (1U5-J12) will be energized and can be used to control or signal for a reduction in the entering condenser water temperature.

Designed to prevent high refrigerant pressure trip-outs during critical periods of chiller operation, this UCP2 option consists of:

1. Condenser refrigerant Pressure Transducer (3R3).
2. The Options Module (1U5) with the head relief request relay (1U5-J12).
3. Interconnecting Wiring.

If the unit is not equipped with the Enhanced Condenser Limit Option (3R31U5) the unit will use the condenser refrigerant temperature sensor (input converted to saturated refrigerant pressure) to perform the Standard Condenser Limit function, without the head relief request relay, by limiting inlet guide vane stroke and chiller capacity.

Keep in mind that the UCP2 Condenser Limit Control supplements the protection provided by the condenser pressure high pressure cutout switch 3S1.

# Electrical Sequence of Operation

---

## Free Cooling

To enable Free Cooling Mode:

1. "Install" Free Cooling in the Machine Configuration Menu.
2. Enable the Free Cooling mode in the Operator Settings Menu to "ON" while the chiller is in "AUTO", or
3. Close the external binary input switch to the Options Module 1U5-J3-5 and -6 if so equipped while the chiller is in "AUTO".

Free Cooling can not be entered if the chiller is in "STOP".

If the chiller is in "AUTO" and not running, the condenser water pump will start. After condenser water flow is proven, relays at 1U5-J16, 1U5-J20, and 1U5-J24 will energize operating the Free Cooling Valves 4B12 and 4B13. The Free Cooling Valves End Switches must open within 3 minutes, or an MMR diagnostic will be generated. Once the Free Cooling Valves End Switches open, the unit is in the Free Cooling mode.

If the chiller is in "AUTO" and running powered cooling, the chiller will do a friendly shut down first, (Run: Unload, Post Lube, and drive vanes closed). After the vanes have been overdriven, closed and condenser water proven, the Free Cooling relays will be energized.

To disable Free Cooling and return to Powered Cooling, either disable the Free Cooling Mode in the Operators Settings menu if used to enable Free Cooling or "OPEN" the external binary input switch to the Options Module if it was used to enable Free Cooling.

Once Free Cooling is disabled, the Free Cooling relays 1U5-J16, and 1U5-J20 and 1U5-J24 will de-energize allowing the Free Cooling valves to close. The Free Cooling valves end switches must close within 3 minutes or an MMR diagnostic is generated.

Once the end switches close the chiller will return to "AUTO" and powered cooling will resume if there is a call for cooling based on the differential to start.

Once powered cooling has resumed and the compressor has started, the inlet guide vanes will be held closed for 3 minutes to allow for temperature/pressure stabilization.

**Note:** The manual control of the inlet guide vanes is disabled while in the Free Cooling Mode and the compressor is prevented from starting by the control logic.

**Note:** The relay at 1U5-J20 is a FC auxiliary relay and can be used as required.

## Hot Gas Bypass

The hot gas bypass (HGBP) control option is designed to minimize machine cycling by allowing the chiller to operate stably under minimum load conditions. In these situations, the inlet guide vanes are "locked" at a preset minimum position, and unit capacity is governed by the HGBP valve actuator.

Control circuitry is designed to allow both the inlet guide vanes and the HGBP valve to close for unit shutdown.

HGBP is enabled in the Field Startup Group of the Service Settings Menus by enabling the option and setting the HGBP Cut-In Vane Position in the same menu.

After a chiller starts and is running the inlet guide vanes will pass through the HGBP Cut-In-Vane position as the chiller starts to load. As the chiller catches the load and starts to unload, the inlet guide vanes will close to the HGBP Cut-In Vane position. At this point the movement of the inlet guide vanes is frozen and further unloading of the chiller is controlled by the opening of the HGBP Valve 4B5 by the 1U10 module. The 1U10 module modulates the HGBP valve

at low loads.

When the control algorithm determines the chiller to be shut down, the inlet guide vanes will be driven fully closed, and the HGBP valve will be driven closed. After the inlet guide vanes are fully closed the chiller will shut down in the Friendly mode.

Chillers with HGBP have a discharge temperature sensor (4RT6) monitoring the discharge gas temperature from the compressor. If this temperature exceeds 200°F, the chiller will shut off on a MAR diagnostic. The chiller will reset automatically when this temperature drops 50°F below the trip-point.

# Electrical Sequence of Operation

---

**Figure 24**  
**Cutout Strategy**

## Cutout Strategy

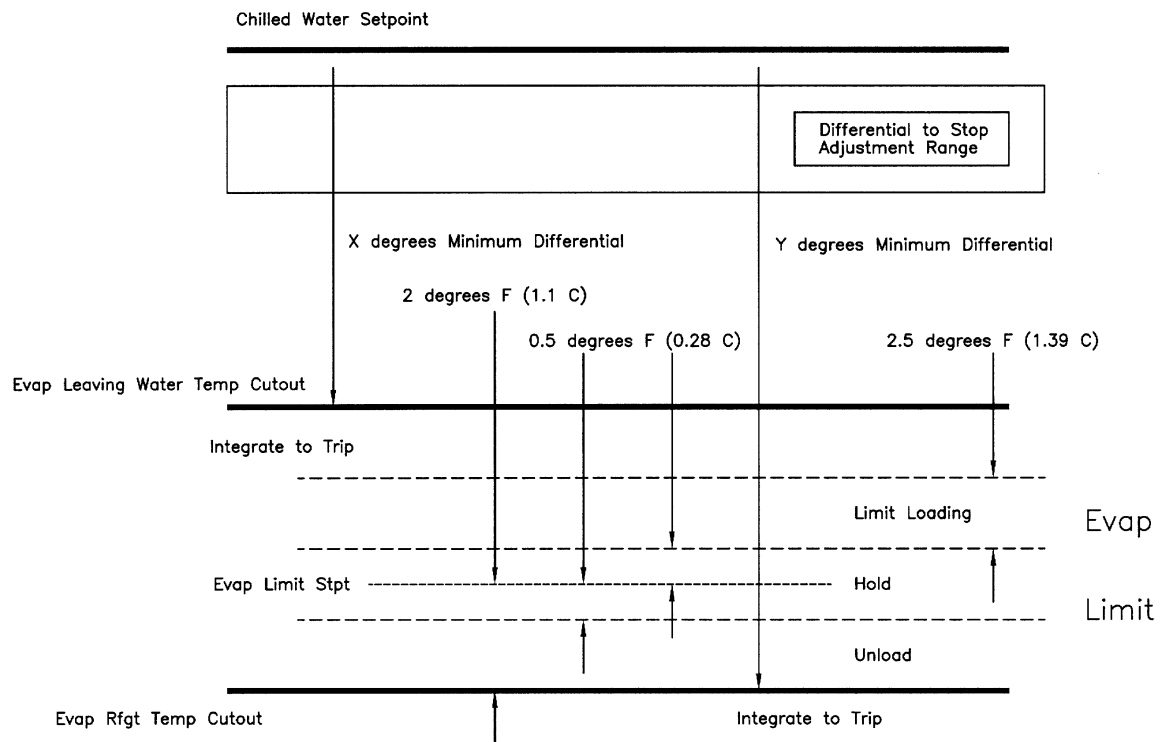

# Electrical Sequence of Operation

---

## Ice Machine Control

UCP2 provides a service level "Enable/Disable" menu entry for the Ice Building feature when the Ice Building option is installed.

UCP2 will accept either an isolated contact closure (J3, 7 & 8 on the options module) or a remote communicated input (Tracer) to initiate the ice building mode where the unit runs fully loaded at all times. Ice building will be terminated either by opening the contact or based on entering evaporator water temperature. UCP2 will not permit the Ice Building mode to be entered again until the unit is switched to the NON-Ice Building mode and back into the Ice Building mode. It is not acceptable to reset the chilled water setpoint low to achieve a fully loaded compressor.

While in the Ice Building mode, current limit setpoints less than the maximum will be ignored.

Ice Building can be terminated by one of the following means:

1. Operating the external ice contacts and remote communicated input (Tracer).
2. Satisfying an evaporator entering water temperature setpoint.
3. Surging for 15 minutes at full open IG.V.

## Unit Start-Up Procedures

### Daily Unit Start-Up

1. Verify the chilled water pump and condenser water pump starter are in "ON" or "AUTO".
2. Verify the cooling tower is in "ON" or "AUTO".

**Note:** Refer to Figure 25 for UCP Start-Run-Shutdown sequence and UCP timing functions.

3. Check the oil tank oil level; the level must be visible in or above the lower sight glass. Also, be sure to

check the oil tank temperature; normal oil tank temperature before start-up is 140°F to 145°F (60 to 63 C).

**Note:** The oil heater is energized during the compressor off cycle. During unit operation, the oil tank heater is de-energized.

4. If the chiller is equipped with the free cooling option, ensure that the free cooling option is disabled in the Operator Settings menu.
5. Check the chilled water setpoint and readjust it, if necessary, in the Operator Settings menu.
6. If necessary, readjust the current limit setpoint in the Operators Setting menu.
7. Press "AUTO".

The UCP also checks compressor motor winding temperature, and a minimum 30 second delay is initiated if the winding temperature is less than 165°F. If it is greater than 165°F, however, a 15-minute delay period begins. The chilled water pump relay is energized and evaporator water flow is proven.

Next, the UCP checks the leaving evaporator water temperature and compares it to the chilled water setpoint. If the difference between these values is less than the start differential setpoint, cooling is not needed.

If the UCP determines that the difference between the evaporator leaving water temperature and chilled water setpoint exceeds the start differential setpoint, the unit enters the initiate Start Mode and the oil pump/Refrigerant pump and the condenser water pump are started. If condenser water flow is not proven (i.e. flow switch 5S3 does not close) within 3 minutes, the unit is locked out on a MMR Diagnostic.

Oil pressure must be verified within 3 minutes or a MMR diagnostic is

generated.

When less than 5 seconds remain on the restart inhibit, the pre-start starter test is conducted on Y-Delta starters. If faults are detected, the unit's compressor will not start, and a MMR Diagnostic will be generated.

If the compressor motor starts and accelerates successfully, "Unit is Running" appears on the display. At this time the purge unit will start operating on "Automatic" and will continue to operate as long as chiller compressor is running.

**Note:** Whenever the UCP detects a MMR diagnostic condition during start-up, unit operation is locked out, and manual reset is required before the start-up sequence can begin again. If the fault condition has not cleared, the UCP will not permit restart.

When the cooling requirement is satisfied, the UCP originates a "Shutdown" signal. The inlet guide vanes are driven closed for 50 seconds, and the unit enters a 3-minute post-lube period. The compressor motor and condenser water pump starter are de-energized immediately, but the oil pump continues to run during this 3-minute interval; the evaporator pump will continue to run.

Once the post-lube cycle is done, the unit returns to auto mode.

# Electrical Sequence of Operation

## Seasonal Unit Start-Up

**Note:** Refer to Figure 25 for UCP Start-Run-Shutdown sequence and UCP timing functions.

1. Close all drain valves, and re-install the drain plugs in the evaporator and condenser headers.

2. Service the auxiliary equipment according to the start-up/maintenance instructions provided by the respective equipment manufacturers.

3. Vent and fill the cooling tower, if used, as well as the condenser and piping. At this point, all air must be removed from the system (including each pass). Then close the vents in the condenser water boxes.

4. Open all of the valves in the evaporator chilled water circuit.

5. If the evaporator was previously drained, vent and fill the evaporator and chilled water circuit. When all air is removed from the system (Including each pass), close the vent valves in the evaporator water boxes.

6. Lubricate the external vane control linkage as needed.

7. Check the adjustment and operation of each safety and operating control.

8. Close all disconnect switches.

 **WARNING**  
**USE CARE WHEN MEASUREMENTS, ADJUSTMENTS, OR OTHER SERVICE-RELATED WORK IS PERFORMED WITH POWER ON. Failure to do so can result in injury or death due electrical shock or contact with moving parts.**

9. Perform instructions listed in "Daily Unit Start-up" section.

 **CAUTION**  
**PROPER SAFEGUARDS SHOULD BE TAKEN TO ENSURE THE EVAPORATOR WATER PUMP DOES NOT CONTINUE TO RUN LONGER THAN 30 MINUTES AFTER CHILLER SHUTDOWN. Failure to avoid excessive operation of the evaporator water pump with chiller off may cause rupture disc failure and loss of refrigerant charge.**

 **WARNING**  
**IF THE CHILLED WATER LOOP IS USED IN A HEATING MODE, ENSURE THAT THE EVAPORATOR IS ISOLATED FROM THE HOT WATER LOOP BEFORE CHANGEOVER TO HEATING MODE. Failure to do so may cause rupture disc failure and loss of refrigerant charge.**

## Unit Shutdown Procedures

### Daily Unit Shutdown

**Note:** Refer to Figure 25 for UCP Start-Run Shutdown sequence and UCP timing functions.

1. Press STOP.

2. After compressor shutdown turn Pump Contactors to OFF or open pump disconnects.

### Seasonal Unit Shutdown

 **CAUTION**  
**CONTROL POWER DISCONNECT MUST REMAIN CLOSED TO ALLOW OIL SUMP HEATER OPERATION. Failure to do this will allow refrigerant to condense in the oil pump.**

3. Open all disconnect switches except the control power disconnect switch.

4. Drain the condenser piping and cooling tower, if used.

5. Remove the drain and vent plugs from the condenser headers to drain the condenser.

6. Once the unit is secured for winter, the maintenance procedures described under "Annual Maintenance" in the Periodic Maintenance section of this manual should be performed by qualified Trane service technicians.

**Note:** During extended shutdown, be sure to operate the purge unit for a 2-hour period every two weeks. This will prevent the accumulation of air and non-condensables in the machine. To start the purge, change the purge mode to ON in the Operator Settings Menu. Refer to CVHE-CLD-1A or latest revision. Remember to turn the purge mode to AUTO after the 2-hour run time.

 **WARNING**  
**DO NOT ALLOW THE CHILLER TO INCREASE IN TEMPERATURE PRESSURE TO A TEMPERATURE ABOVE 110°F (43C) WHILE THE UNIT IS OFF. Failure to do so will cause the rupture disk to relieve and discharge the refrigerant from the machine. Continuous running of pumps while the machine is off may cause this condition to occur. The rupture disk is designed to relieve and discharge the refrigerant from the unit if the pressure in the evaporator exceeds 15 PSIG causing bodily harm and possible death to anyone in contact with refrigerant discharge.**

# Electrical Sequence of Operation

**⚠ WARNING**  
**TO ALLOW OIL SUMP HEATER OPERATION, CONTROL POWER MUST REMAIN CLOSED DURING ENTIRE SHUTDOWN PERIOD.** Failure to do so will allow refrigerant to condense in the oil sump.

**⚠ WARNING**  
**DO NOT ALLOW CHILLER TO INCREASE IN TEMPERATURE OR PRESSURE WHILE THE UNIT IS OFF.** Continuous running of pumps while the chiller is off can increase the temperature or pressure and will result in premature release of refrigerant causing bodily harm and possible death to anyone in contact with refrigerant discharge.

## Trouble Analysis

If the RED light on the control panel is flashing, an MMR diagnostic has occurred. Refer to CVHE-CLD-1A or the latest revision. See the Diagnostic section for trouble shooting information.

**Figure 25**  
**CVHE, CVHF and CVHG - UCP Start-Run-Shutdown Sequence and UCP Timing Functions**

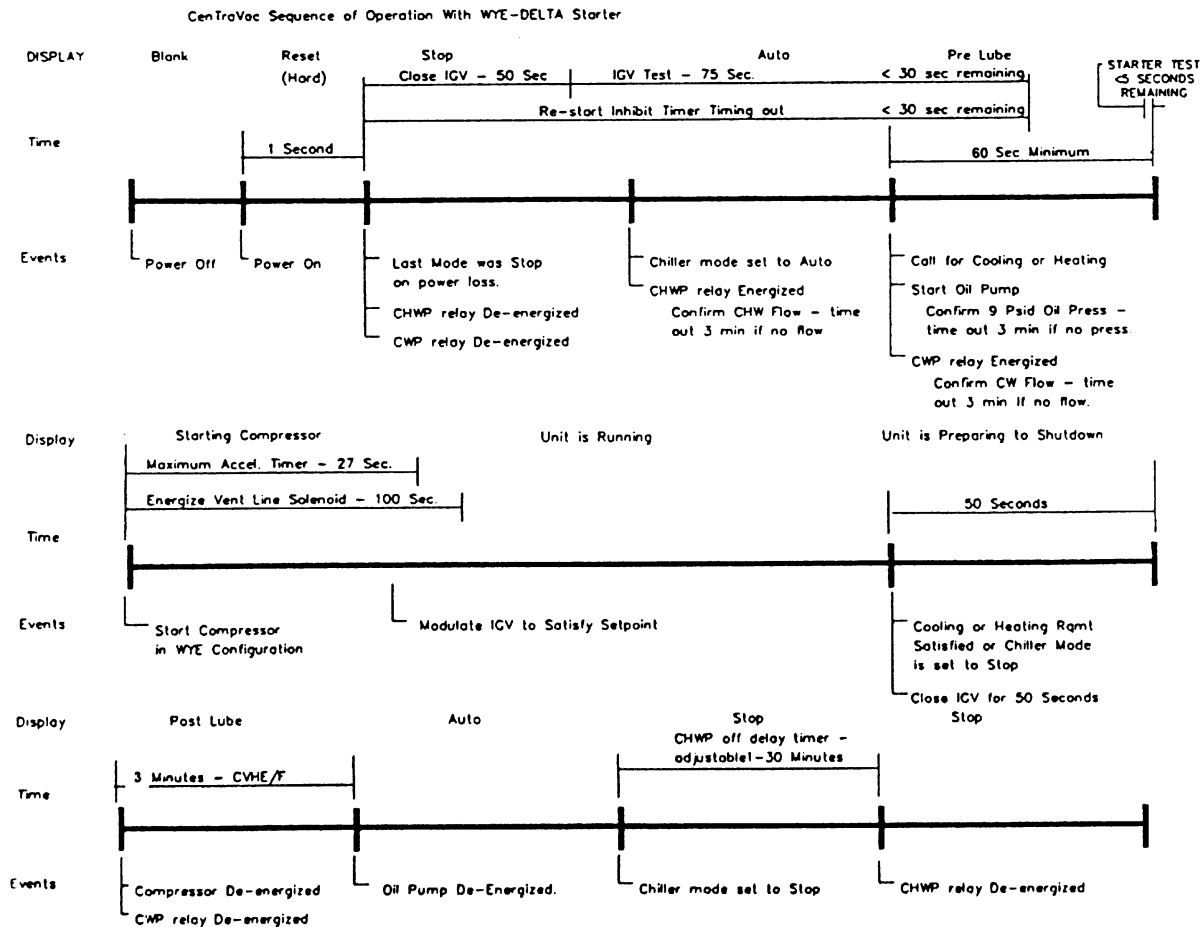

# Electrical Sequence of Operation

---

## Procedure for Selecting Current Overload Settings for UCP2

1. Determine the design condition Rated Load Amps (RLA) from the Unit Nameplate or sales order information.
2. Refer to Table 4 or Table 5 as follows:

Select Table 4 if any of the following conditions are met:

- a. The unit has a Trane supplied starter (unit or remote mounted) and is less than 600 v.
- b. The starter has a single CT per phase, wired directly to the Starter module

Select Table 5 if any of the following conditions are met:

- a. The unit has a starter that was not supplied by Trane.
- b. The unit voltage is 600 v higher.
- c. The starter has two CTs per phase wired to the Starter module.

3. Using Table 4 or Table 5 (determined in Step 2), determine the CT Meter Scale Rating based on the the RLA from Step 1.
4. Calculate the CT factor using one of the following two equations:

If Table 4 was used: (Single CT per phase)

$$\text{CT Factor} = (\text{Motor RLA}/\text{CT Meter Scale Rating}) \times 100$$

If Table 5 was used: (Two CTs per phase)

$$\text{CT Factor} = (\text{Motor RLA}/\text{CT Meter Scale Rating}) \times 139$$

5. Refer to Table 6. Determine Current Overload Settings #1 and #2 based on the CT Factor that was calculated in Step 4 above.

Enter and verify the correct Current Overload Setting #1 and Current Overload Setting #2 in the unit control menus.

**Table 4**

**CT Factor = (Motor RLA/CT Meter Scale Rating) x 100**

Current Transformer Selection Table for Single CT/Phase Systems			
Motor RLA	CT Part No.	Ext	CT Meter Scale Rating
34-50A	X13580253 or X13580269	09	50A
51-67A		10	75A
68-100A		01	100A
101-134A		02	150A
135-184A		03	200A
185-267A		04	275A
268-334A		05	400A
335-467A		06	500A
468-667A		07	700A
668-935A		08	1000A
936-1260A		11	1400A
1261-1620A		12	1800A

# Electrical Sequence of Operation

---

**Table 5**  
CT-Factor = (Motor RLA/CT Meter Scale Rating) x 139

Current Transformer Selection Table for Two CT/Phase Systems							
Line CT Part No.	Ext	Line CT Ratio	CT Ter. Conn	No. of Prim. Turns	RLA Ranges	Meter Scale	
X13580272	-01	50:5	X1 to X2	3	8.0 - 11.9	16.7	
				2	12.0 - 17.9	25.0	
	-02	75:5		2	18.0 - 23.9	37.5	
	-01	50:5			24.0 - 35.9	50	
X13580271	-02	75:5	X1 to X3	1	36.0 47.9	75	
		100:5			48.0 -72.0	100	
X13580048	-01	150:5	X1 to X4	1	72.0 to 86.3	150	
		180:5			X1 to X3	86.4 to 95.9	180
		200:5			X1 to X4	96.0 to 119.9	200
		250:5			X1 to X2	120.0 to 143.9	250
	-02	300:5	X1 to X3		144.0 to 167.9	300	
		350:5	X1 to X4		168.0 to 191.9	350	
		400:5	X1 to X2		192.0 to 239.9	400	
		500:5	X1 to X3		240.0 to 287.9	500	
	-03	600:5	X1 to X4		288.0 to 235.9	600	
		700:5	X1 to X2		336.0 to 383.9	700	
		800:5	X1 to X3		384.0 to 479.9	800	
		1000:5	X1 to X4		480.0 to 575.9	1000	
	-04	1200:5	X1 to X2		576.0 to 719.9	1200	
		1500:5	X1 to X3		720.0 to 863.9	1500	
		1800:5	X1 to X2		864.0 to 1007.9	1800	
		2100:5	X1 to X3		1008.0 to 1199.9	2100	
X13580047	-01	2500:5	X1 to X4	1200.0 to 1800	2500		
		1000:5	X1 to X2	480.0 to 575.9	1000		
	-02	1200:5	X1 to X3	576.0 to 719.9	1200		
		1500:5	X1 to X4	720.0 to 863.9	1500		

(For medium and high voltage applications, not to exceed 6600 volts).

**Table 6**  
CT Factor, Current Overload Settings #1 and #2

CT Factor	Current Overload Setting #1	Current Overload Setting #2
66	00	255
67	01	254
68	02	253
69	03	252
70	04	251
71	06	249
72	07	248
73	08	247
74	09	246
75	10	245
76	11	244
77	12	243
78	13	242
79	15	240
80	15	240
81	16	239
82	17	238
83	18	237
84	19	236
85	20	235
86	21	234
87	22	233
88	22	233
89	23	232
90	24	231
91	25	230
92	25	230
93	26	229
94	27	228
95	28	227
96	28	227
97	29	226
98	30	225
99	30	225
100	31	224

# Periodic Maintenance

## Overview

This section describes the basic chiller preventive maintenance procedures, and recommends the intervals at which these procedures should be performed. Use of a periodic maintenance program is important to ensure the best possible performance and efficiency from a CenTraVac® chiller.

Recommended purge maintenance procedures for the Purifier Purge unit are covered by PRG-OM-6A or the latest revision which can be obtained at the nearest Trane office.

## Record Keeping Forms

An important aspect of the chiller maintenance program is the regular completion of records. Provided at the end of this manual are copies of the "Annual Inspection Check List and Report", "CenTraVac with UCP2 Commissioning Checklist and "Start-Up Test Log", a "Start-Up Test Log for Water Cooled CenTraVacs with UCP2 Control Panels" and "UCP2 "Settings Group" Menu Record". When filled out accurately by the machine operator, the completed logs can be reviewed to identify any developing trends in the chiller's operating conditions.

For example, if the machine operator notices a gradual increase in condensing pressure during a month's time, he can systematically check, then correct the possible cause (s) of this condition (e.g., fouled condenser tubes, non-condensable in the system, etc.)

## Daily Maintenance and Checks

[ ] Check the chiller's evaporator and condenser pressures, oil tank

pressure, differential oil pressure and discharge oil pressure. Compare the readings with the values provided in Table 7.

**IMPORTANT: IT IS HIGHLY RECOMMENDED THAT THE OPERATING LOG BE COMPLETED ON A DAILY BASIS.**

**CAUTION**  
**IF FREQUENT PURGING IS REQUIRED, MONITOR PURGE PUMPOUT RATE, IDENTIFY AND CORRECT SOURCE OF AIR OR WATER LEAK AS SOON AS POSSIBLE. Failure to do so can shorten chiller life expectancy, due to moisture contamination caused by leakage.**

[ ] Check the oil level in the chiller oil sump using the 2 sight glasses provided in the oil sump head. When the unit is operating, the oil level should be visible in the lower sight glass.

## Weekly Maintenance

[ ] Complete all recommended daily maintenance procedures and checks. Complete logs on a daily basis.

**WARNING**  
**WHEN SERVICING, LOCK UNIT DISCONNECT SWITCH IN OPEN POSITION. Failure to do so, may result in death or injury due to electrical shock or contact with moving parts.**

## Every 3 Months

[ ] Complete all recommended weekly maintenance procedures. Refer to the previous sections for details.

[ ] Clean all water strainers in the CenTraVac water piping system.

## Every 6 Months

**WARNING**  
**WHEN SERVICING, LOCK UNIT DISCONNECT SWITCH IN OPEN POSITION. Failure to do so, may result in death or injury due to electrical shock or contact with moving parts.**

**Table 7**  
**Normal Chiller Operating Characteristics**

Operating Characteristic	Normal Reading
Evaporator Pressure	12" to 18" Hg (Vacuum)
Condenser Pressure (See Notes 1 and 2)	2 to 12 PSIG (Standard Condensers)
Oil Sump Temperature:	
Unit Not Running	140 to 145 F (60 to 63)
Unit Running	62° F to 162° F (16.7°C to 72°C)
Differential Oil Pressure	18 to 22 psid

# Periodic Maintenance

[ ] Complete all recommended quarterly maintenance procedures.

[ ] Lubricate the vane control linkage bearings, ball joints, and pivot points; as needed a few drops of light machine oil (e.g., SAE-20) is sufficient.

[ ] Lubricate first stage vane operator tang "O" rings by removing the setscrew and adding several drops of Trane Oil 0022. Replace setscrew. On CVHF 1470/1720 compressors remove fill and vent hole setscrews. Add grease (Rheolube 434a) until excess appears in vent hole. Replace setscrews.

[ ] Lubricate the oil filter shutoff valve "O" rings by removing the pipe plug and adding several drops of Trane Oil 0022. Replace plug.

[ ] Drain the contents of the rupture disc/purge discharge ventline drip-leg, into an evacuated waste container minimally and more often if the purge is operated excessively.

Also, apply 1 or 2 drops of oil on the vane operator shaft and spread it into a very light film; this will protect the shaft from moisture and rust.

## Off-Season Maintenance

During those periods of time when the chiller is not operated, be sure the control panel is energized. This is to keep the purge operational, the oil heater warm and will also keep air out of the machine.

## Annual Maintenance

Shut down the chiller once each year to check the items listed ; a more detailed inspection checklist is provided on the "Model CVHE, CVHF and CVHG CenTraVac Annual Inspection Checklist and Report" illustrated in this manual.

[ ] Perform the annual maintenance procedures referred to in the Maintenance Section of the purge manual.

[ ] Use an ice water bath to verify that the accuracy of the evaporator refrigerant temperature sensor (4RT5) is still within tolerance (i.e., + or - 2.0° at 32°F).

If the evaporator refrigerant temperature displayed on the UCP's read-out is outside this 4-degree tolerance range, replace the sensor.

**Note:** If the sensor is exposed to temperature extremes outside its normal operating range (0°F to 90°F) (-18°C to 32°C), check its accuracy at 6-month intervals.

## Compressor Oil Change on CVHE, CVHF, CVHG

After the first six months of operation it is recommended to have the oil analyzed.

After 1000 hours and one year of operation it is recommended to change the oil and filter and have the removed waste oil analyzed.

Note: Use only Trane Oil 0022. A full oil change is 9 gallons of Oil 0022 with refrigerant pump and 7-1/2 gallons without refrigerant pump.

Beyond the first year, recommendations are to subscribe to an annual oil analysis program rather than change the oil

automatically every year. This program will reduce the chiller's overall lifetime oil consumption and minimize refrigerant emissions. The oil analysis should be done by a qualified laboratory experienced in refrigerant/oil chemistry and the servicing of Trane centrifugal chillers.

In conjunction with other diagnostics performed by a qualified service technician, oil analyses can provide valuable information on the performance of the chiller to help minimize operating and maintenance costs and maximize it's operating life. A drain fitting is installed in the oil filter top, after the oil filter, for obtaining oil samples.

## Oil Change Procedure

When oil analysis indicates the need to change compressor oil, use the following procedure for removing oil.

 **CAUTION**  
**BE SURE TO OPEN CONTROL PANEL DISCONNECT SWITCH BEFORE DRAINING THE SUMP. Failure to do so could possibly burn out the oil sump heater.**

[ ] Draw the oil from the chiller through the oil charging valve on the chiller oil sump into an approved, evacuated tank; or,

[ ] Pump the oil from the chiller through the oil charging valve into an air-tight resealable container, using a magnetically-driven auxiliary pump.

Forcing the oil from the oil sump by pressurizing the chiller (i.e. by raising chiller temperature or adding nitrogen) is not recommended.

Refrigerant dissolved in the oil can be removed and returned to the chiller by using an appropriate

# Periodic Maintenance

---

deep-vacuum recovery unit and heating/agitating the oil container. Follow all Federal, State and Local regulations with regard to disposal of waste oil.

## Replacing Oil Filter

Replace oil filter: (1) annually, (2) at each oil change, (3) or if erratic oil pressure is experienced during chiller operation.

## Oil Filter Replacement

Use the following procedure to service the oil filter. Refer to Figure 26.

1. Run the oil pump for two to three minutes to insure that the oil filter is warmed up to the oil sump temperature.
2. Turn the oil pump motor off.
3. Pull the "D" handle on the rotary valve locking pin out of its detent and rotate the valve to the "DRAIN" position. An offset pointer is located on top of the valve with wrench flats to allow turning. the spring force on the locking pin should allow the pin to drop into a detent at this position.
4. Allow at least 15 minutes for the oil to drain from the filter back into the oil sump.
5. Pull the "D" handle to unlock the pin and rotate the valve to the "Change Filter" position. This isolates the filter from the unit. The locking pin should drop into a detent in this position.
6. Remove and replace the filter as quickly as possible. Tighten filter 2/3 to 3/4 turn per instructions written on the filter. Place the used filter in a reusable container. Follow all local, state and federal regulations to dispose of the filter.

Pull the "D" handle to unlock the pin and rotate the valve to the "RUN" position. The locking pin should drop into a detent in this position. The chiller is now ready for operation.

## Other Maintenance Requirements

Compressors using new seal technology will not use O-rings. The O-ring has been replaced by Loctite 515 applied at a minimum film thickness of .010 applied across the width of the flange. The current jack bolt holes remain for disassembly.

 **CAUTION:**  
**USE CARE WHEN APPLYING LOCTITE ON A JOINT. Failure to do so could result in Loctite getting into the chiller which may cause problems with the Oil supply system and eductor system.**

Inspect the condenser tubes for fouling; clean if necessary.

Measure the compressor motor winding resistance to ground; a Qualified Service Technician should conduct this check to ensure that the findings are properly interpreted.

Contact a qualified service organization to leak-test the chiller; this procedure is especially important if the system requires frequent purging.

Use a nondestructive tube test to inspect the condenser and evaporator tubes at 3-year intervals.

Note: It may be desirable to perform tube tests on these components at more frequent intervals, depending upon chiller application. This is especially true of critical process equipment.

Depending on chiller duty, contact a qualified service organization to determine when to conduct a complete examination of the unit to discern the condition of the compressor and internal components.

**Note:** (a) Chronic air leaks, which can cause acidic conditions in the compressor oil and result in premature bearing wear; and, (b) Evaporator or condenser water tube leaks. Water mixed with the compressor oil can result in bearing pitting, corrosion, or excessive wear.

# Periodic Maintenance

---

[ ] Submit a sample of the compressor oil to a Trane qualified laboratory for comprehensive analysis on an annual basis; this analysis determines system moisture content, acid level and wear metal content of the oil, and can be used as a diagnostic tool.

## Lubrication

The only CVHE, CVHF and CVHG chiller component that requires periodic lubrication is the external vane linkage assembly and Rotary oil valve.

Lubricate the vane linkage shaft bearings and rod end bearings as needed with a few drops of light-weight machine oil.

Lubricate the 1st Stage IGV actuator O-Rings, by removing the pipe plug and adding several drops of Trane Oil 0022. Be sure and reinstall pipe plug.

The oil valve block rotary valve uses dual O'Rings to seal to atmosphere. These should be manually lubricated by removing the pipe plug at the valve lubrication port and placing a few drops of Trane Oil 0022 in the cavity. Be sure to reinstall the pipe plug when lubrication is completed.

# Periodic Maintenance

---

Figure 26  
Rotary Valve in Drain Position

NOTE: ROTARY VALVE SHOWN IN DRAIN POSITION.

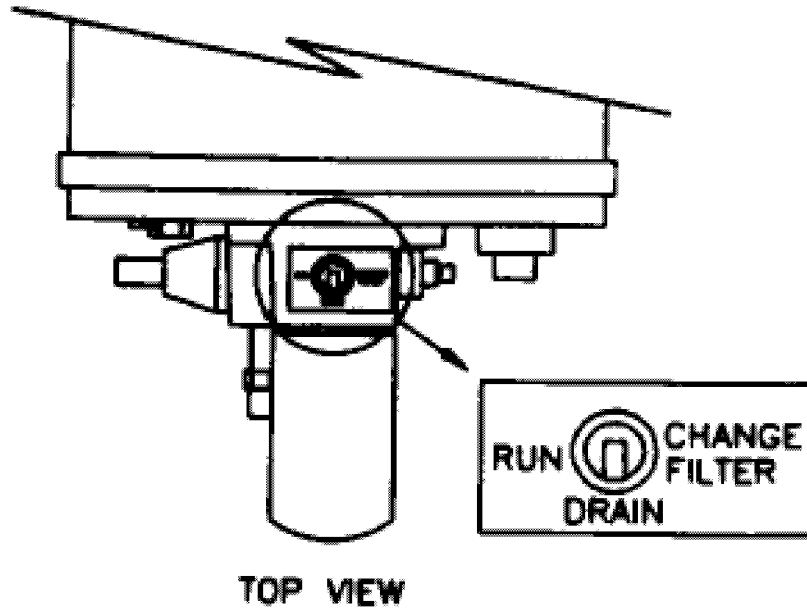

Front View with  
Refrigerant Pump

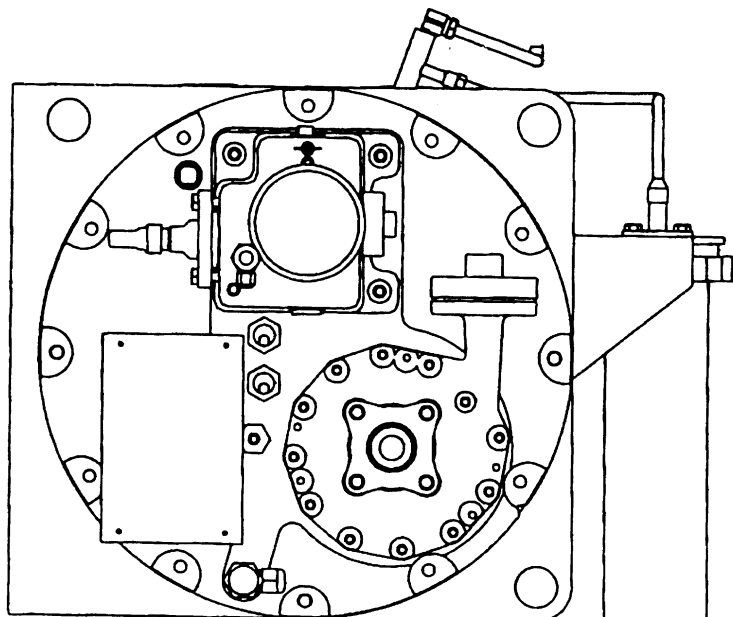

# Periodic Maintenance

---

## Refrigerant Charge



### WARNING

**CERTAIN PROCEDURES COMMON TO REFRIGERANT SYSTEM SERVICE MAY EXPOSE OPERATING AND/OR SERVICING PERSONNEL TO LIQUID AND/OR VAPOROUS REFRIGERANT. CLOSELY FOLLOW ALL SAFETY PROCEDURES DESCRIBED IN THE MATERIAL SAFETY DATA SHEET FOR THE REFRIGERANT CONTAINERS. Failure to do so could result in death or injury due to inhalation of, or skin exposure to refrigerant.**

The refrigerant charging procedure for Trane centrifugal chillers is:

1. If water is present in the tubes, break machine vacuum with refrigerant vapor, or circulate water, to avoid tube damage.
2. Always use refrigerant compatible hoses or copper-tubing with self-sealing connections or shut-off valves.
3. Transfer the refrigerant using one of the following (listed in order of preference):
  - a. An approved Trane low-pressure refrigerant recovery/recycle unit.
  - b. The available pressure differential.
  - c. Gravity. (Use a return vent line to refrigerant drums to equalize pressure.)

5. Do not use dry nitrogen to push refrigerant into the chiller as was common practice in the past. This will contaminate the charge and require excessive purging, which will result in unnecessary release of refrigerant.

6. Weigh in the proper charge.

7. Use recovery/recycle unit or vacuum pump to evacuate hoses; discharge outdoors.

8. If refrigerant is supplied in new returnable cylinders, be sure and refer to General Service Bulletin CVHE-SB-48B for information on returning cylinders. This service bulletin is available at the nearest Trane office.

Depending on the chiller duty, contact a qualified service organization to determine when to conduct a complete examination of the unit to discern the condition of the compressor and internal components.

**Note:** If your chiller is covered by a Trane extended warranty, the terms of that warranty may require that the procedures listed in the Periodic Maintenance section of this manual be followed for your extended warranty to remain in force. The terms may also require that the chiller be inspected by a Trane authorized warranty agent every 4 years or 40,000 operating hours, whichever occurs first. This inspection will include, at a minimum, a review of the annual inspection checklists and the daily operating logs, as well as performance of a leak test and a general inspection of the chiller. The owner is then required to follow the recommendations made as a result of this inspection at the owners expense.

# Periodic Maintenance

## Recovery and Recycle Connections

To facilitate refrigerant removal and replacement, newer-design CVHE, CVHF and CVHG units are provided with a 3/4-inch vapor fitting with shutoff valve on the chiller suction and with a 3/4-inch liquid connection with shutoff valve at the bottom of the evaporator shell.

## Leak Testing

To leak-test a chiller containing full refrigerant charge, raise chiller pressure using a controlled hot water or electric-resistance system to a maximum of 8 psig. Do not use nitrogen, which will cause excessive refrigerant discharge by the purge system.

## Cleaning the Condenser



### CAUTION

**DO NOT USE UNTREATED OR IMPROPERLY TREATED WATER. Failure to follow this caution could result in damaged equipment.**

See Figure 27 which shows a Typical Chemical Cleaning Setup.

Figure 27  
Typical Chemical Cleaning Setup

Chemical Cleaning Setup

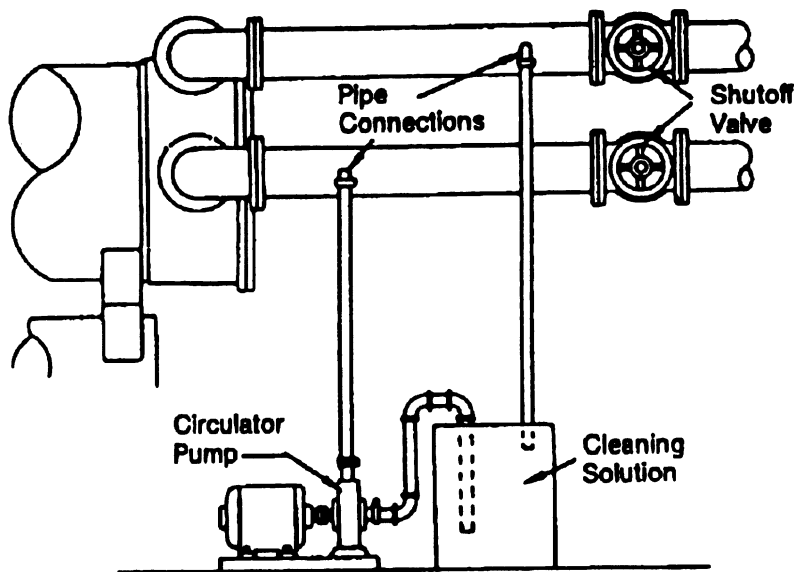

# Periodic Maintenance

---

Condenser tube fouling is indicated when the approach temperature (the difference between the condensing refrigerant temperature and the leaving condenser water temperature) is higher than predicted.

If the annual condenser tube inspection indicates that the tubes are fouled, two cleaning methods, mechanical and chemical, can be used to rid the tubes of contaminants.

Use the mechanical cleaning method to remove sludge and loose material from smooth-bore tubes.

(To clean other types of tubes including internally-enhanced types, consult a qualified service organization for recommendations).

1. Remove the retaining nuts and bolts from the water box covers at each end of the condenser. Use a hoist to lift the covers off the water box. (A threaded connection is provided on each water box cover to allow insertion of an eyebolt).

2. Work a round nylon or brass bristled brush (attached to a rod) in and out of each of the condenser water tubes to loosen the sludge.

3. Thoroughly flush the condenser water tubes with clean water.

Scale deposits are best removed by chemical means. Be sure to consult any qualified chemical house in the area (i.e., one familiar with the local water supply's chemical mineral content) for a recommended cleaning solution suitable for the job. Remember, a standard condenser water circuit is composed solely of copper, cast iron and steel.



## CAUTION

**USE CARE WHEN CHEMICAL CLEANING THE UNIT. Failure to do so can damage the unit.**

*IMPORTANT: ALL OF THE MATERIALS USED IN THE EXTERNAL CIRCULATION SYSTEM, THE QUANTITY OF THE SOLUTION, THE DURATION OF THE CLEANING PERIOD, AND ANY REQUIRED SAFETY PRECAUTIONS SHOULD BE APPROVED BY THE COMPANY FURNISHING THE MATERIALS OR PERFORMING THE CLEANING.*

*REMEMBER, HOWEVER, THAT WHENEVER THE CHEMICAL TUBE CLEANING METHOD IS USED, IT MUST BE FOLLOWED UP WITH MECHANICAL TUBE CLEANING, FLUSHING AND INSPECTION.*

## Cleaning the Evaporator

Since the evaporator is typically part of a closed circuit, it does not accumulate appreciable amounts of scale or sludge. Normally, cleaning every 3 years is sufficient. However, on open CVHE, CVHF and CVHG systems, such as air washers, periodic inspection and cleaning is recommended.

## Control Settings and Adjustments

A list of CVHE, CVHF and CVHG time delays and safety control cutout settings is provided in Table 1 in the Chiller Control System section of this manual. For control calibration and check-out, contact a Trane qualified service organization.

## Purge System

Because some sections of the chiller's refrigeration system operate at less-than-atmospheric pressure, the possibility exists that air and moisture may leak into the system. If allowed to accumulate, these non-condensibles become trapped in the condenser; this increases condensing pressure and compressor power requirements, and reduces the chiller's efficiency and cooling capacity.

The Trane Purifier Purge is the only purge system available for the CVHE, CVHF and CVHG chiller. The purge is designed to remove non-condensable gases and water from the refrigeration system. Purifier Purge unit operation, maintenance and trouble shooting is covered by a separate operation and maintenance manual, PRG-OM-6A or the latest issue, which may be obtained from the nearest Trane office.

# Installed Unit Extended Storage

## Overview

This section describes extended storage requirements for UCP2 installed CVHE, CVHF and CVHG chillers to be removed from service for an undetermined length of time.

## Unit Preparation

The following steps are necessary in order to properly prepare a unit for storage.

1. Remove all liquid refrigerant if the unit is charge.

 **WARNING**  
**TO AVOID INJURY OR DEATH DUE TO INHALATION OF, OR SKIN EXPOSURE TO REFRIGERANT, CLOSELY FOLLOW ALL SAFETY PROCEDURES DESCRIBED IN THE MATERIAL SAFETY DATA SHEET. Failure to do so may expose operating and/or servicing personnel to liquid and/or vaporous refrigerant.**

2. After the liquid refrigerant is removed, using a recovery/recycle unit or vacuum pump, pull a vacuum to remove remaining refrigerant vapor from the unit.

3. After all traces of refrigerant are out of the unit, a positive nitrogen charge should be put into the unit (6 to 8 psig). This positive pressure must be checked monthly to insure no noncondensibles get into the unit. Use a pressure gage on the evaporator shell to verify that the 6 to 8 psig dry nitrogen holding charge is still in the chiller. If this charge has escaped, contact a qualified service organization and the Trane sales engineer that handled the order.

4. The refrigerant charge should be stored in proper refrigerant containers. Due to possible leakage, do not store in used drums.

5. Maintain control power to the control panel. This will maintain oil temperature in the oil sump and the capability of the control panel to present report information. The Chiller, Refrigerant and Compressor Reports should be viewed once a week for normal readings. Any abnormal observation must be reported to the Trane Sales Engineer that handled the order.

 **WARNING**  
**USE CARE WHEN MEASUREMENTS, ADJUSTMENTS OR OTHER SERVICE-RELATED OPERATIONS ARE PERFORMED WITH POWER ON. Failure to do so could result in death due to electrical shock or contact with moving parts.**

6. Remove the factory installed jumper or the field installed wiring on terminals J5-1 and J5-2 on the 1U1 Chiller Module in the unit control panel. This will prevent unwanted chiller operation.

7. Set the purge operating mode to OFF on UCP2 chillers.

8. The oil can be left in the unit.

9. The water side should not cause a problem if shut down and drained. There may be slight scaling inside the tubes, but not enough to cause a problem. Customer should inspect and clean tubes before the unit is returned to service.

**IMPORTANT: DO NOT USE UNTREATED OR IMPROPERLY TREATED WATER, OR EQUIPMENT DAMAGE MAY OCCUR.**

**IMPORTANT: SCALE DEPOSITS ARE BEST REMOVED BY CHEMICAL MEANS. BE SURE TO CONSULT ANY QUALIFIED CHEMICAL HOUSE IN THE AREA (I.E., ONE FAMILIAR WITH THE LOCAL WATER SUPPLY'S CHEMICAL MINERAL CONTENT) FOR A RECOMMENDED CLEANING SOLUTION SUITABLE FOR THE JOB.**

10. Motor bearings: If the motor sits for a long time the bearings could take a set and cause bearing problems/replacement later. Once every six months the chiller oil pump must be started and the compressor motor bump started to rotate the shaft. Contact a qualified service organization to perform this task. If the compressor motor cannot be bump started, then the shaft must be rotated manually by a qualified service organization.

11. Obtain an oil analysis initially after 6 months of storage, and once each succeeding year. If no oil breakdown is evident do not change the oil. If breakdown is evident, the oil must be replaced.

12. If the unit is stored for more than five years, and the storage is expected to be indefinite, the unit should be examined for leaks every five years from the initial storage date.

13. When the unit is to be returned to service, the services of a qualified service organization should be obtained to conduct all activities associated with the startup of a new chiller.

# Forms

---

## Annual Inspection Check List and Report: CenTraVacs® w/UCP2 Control Panels

### Compressor Motor

- Motor continuity check  
Good  Open

- Check and tighten motor terminals

- Meg motor  
Phase 1  Phase 2  Phase 3

- Check nameplate rating  
Amps

### Starter

- Check condition of starter contacts  
Good  Fair  Replace

### Oil Sump

- Change oil  
If oil analysis, refer to program procedures  
 Gallons (7) required

- Oil pump motor ground check  
Good  Open

- Check motor terminals
- Change oil filter

### Condenser

- Visually inspect for scaling in tubes:  
note findings and make recommendations

### Control Circuits

- Low refrigerant temperature sensor check-out  
\_\_ F set point \_\_ F trip point (ice water)

- Leaving Evaporator water temperature sensor  
check-out  
\_\_ F set point \_\_ F trip point (ice water)

- Condenser High Pressure Switch check-out  
\_\_ psig set point  
\_\_ psig trip point

- Check Net Oil Pressure

- Check adjustment and operation of inlet guide  
vane actuator stepper motor. The stroke of the  
actuator motor is 10,000 steps/in and  
approximately 46,000 to 54, 000 steps full stroke.  
(**Note:** each machine is unique and must have the  
90° number of steps input.)

### Leak Test Chiller

Refrigerant and oil analysis for acid content.

- Sample refrigerant and oil for laboratory analysis  
(attach copy of analysis to next monthly  
inspection report)

### Purge Unit

- Perform the purge system control check  
described in "Control Circuit Diagnostics" in the  
"Troubleshooting" section of the most current  
Purge operation and maintenance manual.

Comments:

---

---

---

Recommendations:

---

---

---

Note: This form is suggested for your use.

# Forms



## CenTraVac® Checksheet and Request for Serviceman

To: \_\_\_\_\_ Trane Service Company

S.O. No.: \_\_\_\_\_ Serial No.: \_\_\_\_\_

Job/Project Name: \_\_\_\_\_

The following items are being installed and will be complete by \_\_\_\_\_

### 1. CenTraVac

In place and piped. Do not insulate CenTraVac or adjacent piping. The contractor is responsible for any foreign material left in the unit.

### 2. Piping

Chilled water piping connected to:  
CenTraVac   
Air handling units   
Pumps

Condenser and heat recovery condenser (as applicable) piping connected to:  
CenTraVac   
Pumps   
Cooling tower   
Heating loop

Make-up water connected to cooling tower   
Water supply connected to filling system   
Systems filled   
Pumps run, air bled from system   
Strainers cleaned

### 3. Flow Balancing Valves Installed

Leaving chilled water   
Leaving condenser water   
Heat recovery condenser leaving water

### 4. Wiring

Compressor motor starter has been furnished by or approved by The Trane Company, La Crosse, WI   
Power available   
Interconnecting wiring, starter to control panel   
External interlock (flow switches, water pump aux., etc.)

### Motors connected on:

CenTraVac\*   
Chilled water pump   
Cooling tower fan rotation checked   
Condenser water pump   
Heat recovery condenser water pump (as applicable)   
Power available for vacuum pump (115V AC)   
All controls installed and connected   
All magnetic starters installed and connected

\*NOTE: Do not make final connections to compressor motor until requested by Trane Service Representative.

### 5. Testing

Dry nitrogen available for pressure testing   
Trace gas amounts of Refrigerant-22 available for leak testing, if necessary

### 6. Refrigerant On Job Site

### 7. Gauges, Thermometers and Air Vents

Installed on both sides of evaporator   
Installed on both sides of condenser and heat recovery condenser (as applicable)

### 8. System Can Be Operated Under Load Conditions

### 9. Electrician, Control Man and Contractor's Representative Are Available to Evacuate, Charge and Test the CenTraVac under Serviceman's Supervision

In accordance with your quotation and our purchase order number \_\_\_\_\_

We will therefore require your serviceman on the job by\*\* \_\_\_\_\_

This is to certify that the CenTraVac(s) has been properly and completely installed and the applicable items listed above have been completed.

\*\*Advance notification is required to allow scheduling of the start-up as close to the requested date as possible.

# Forms

---

## Compliance To ASHRAE Standard 15

- |     |    |  |
|-----|----|--|
| Yes | No | 1. Is this an outdoor installation? If yes, skip to "Owner Awareness of Safe Refrigerant Handling Procedures".   |
| Yes | No | 2. Does the equipment room have a refrigerant monitor/sensor capable of monitoring and alarming within the acceptable exposure level (AEL) of the refrigerant? |
| Yes | No | 3. Does the equipment room have an audible or visual alarm (other than the light on the monitor) which is controlled by the monitor?                           |
| Yes | No | 4. Does the equipment room have mechanical ventilation?†   |
| Yes | No | 5. Is a self-contained breathing apparatus required by local building code? If no, go to question 7.   |
| Yes | No | 6. Is a self-contained breathing apparatus available in close proximity of the equipment room?   |
| Yes | No | 7. Are the purge discharge and the rupture disk piped to the outdoors?   |

† The mechanical ventilation consists of two flow requirements i.e., a two-speed fan where the high speed is sized by the formula  $Cfm = 100 \times$  the square root of the pounds of refrigerant of the largest chiller, and low speed is 0.5 Cfm per square foot of the equipment room space. (This requirement is for chillers located within the building which is the most common.)

## Owner Awareness Of Safe Refrigerant Handling Procedures

- |     |    |  |
|-----|----|--|
| Yes | No | 1. Has the owner been fully instructed on the proper use of refrigerant 123?                       |
| Yes | No | 2. Was the owner given a copy of the MSDS for HCFC-123?  |
| Yes | No | 3. Was the owner given a copy of Trane publication "CFC-GUIDE-2, Refrigerant Handling Guidelines"? |

Additional time required to complete the start-up and adjustment due to incompleteness of the installation will be invoiced at prevailing rates.

Serial Number \_\_\_\_\_

Serial Number \_\_\_\_\_

Serial Number \_\_\_\_\_

Serial Number \_\_\_\_\_

Serial Number \_\_\_\_\_

Checklist Completed By: \_\_\_\_\_

\_\_\_\_\_

\_\_\_\_\_

Signed: \_\_\_\_\_

Dated: \_\_\_\_\_

### Notice To Trane Service Agency:

A copy of this completed form must be submitted to the CenTraVac Technical Service Department in La Crosse, WI, prior to the actual start-up date.

1-27.08-6

# Forms

 <b>TRANE®</b>	<b>CENTRAVAC WITH UCP2 COMMISSIONING CHECKLIST &amp; START-UP TEST LOG</b>
---	--

Job name \_\_\_\_\_  
Model # \_\_\_\_\_  
Sales Order # \_\_\_\_\_

Location \_\_\_\_\_  
Serial # \_\_\_\_\_  
Start-up Date \_\_\_\_\_

NOTE: The Unit Installation, Operation and Maintenance Manuals, Submittals, and Design Specifications must be used in conjunction with this checklist. (INCLUDING WARNINGS AND CAUTIONS)

## I. PRECOMMISSIONING PROCEDURES

### A. Obtain Installation Check Sheet

This must be prepared by installer for a particular unit, verifying the unit is ready for commissioning.

### B. Obtain Design (order) Specification Data

This indicates the design criteria of the particular unit. A unit cannot be properly commissioned unless this data is known. It is the responsibility of the selling office to furnish this data.

### C. Obtain Wiring Diagrams

The "as-wired" electrical diagram should be compatible with the recommended Trane submittals and diagrams. Are customer added external/remote control circuits compatible?  Yes  No

### D. General Installation Observations

- 1. Is there any apparent shipping or rigging damage?  Yes  No
- 2. Record the pressure on the shipping gauge \_\_\_\_\_ PSIG. If there is no pressure on the gauge, A leak test will have to be done before the unit can be evacuated and charged.
- 3. Is the water piping correctly installed?  Yes  No  
Flow Switches  Yes  No      Pressure Gauges  Yes  No  
Isolations Valves  Yes  No      Flow Balancing Valves  Yes  No  
Thermometer Wells  Yes  No      Vent Cocks and Drains  Yes  No
- 4. Have proper clearances around the unit been maintained per submittal and/or Installation Are there Manual guidelines available?  Yes  No
- 5. Is power wiring of adequate ampacity and correct voltage?  Yes  No  
Are fuses or circuit breakers of the correct value or type?  Yes  No
- 6. Is the unit base acceptable, level, and is the unit on isolators (rubber as supplied by Trane or spring type)?  Yes  No
- 7. Have the micro (less than 30 volts) circuits been properly isolated from the higher voltage control and power circuits?  Yes  No

E. Comments \_\_\_\_\_  
\_\_\_\_\_  
\_\_\_\_\_

# Forms

---

## II. COMMISSIONING PROCEDURES

### A. Pre-start Operations

#### 1. Holding Charge

- \_\_\_\_\_ PSIG. Must be positive pressure or leak test must be done.
- Before relieving the holding charge, calibrate the H.P.C. high-pressure control. This is a check of pressure to the H. P. C. as well as calibration of the control. Disconnect and cap the flare. Calibrate H.P.C. reconnect flare.
- Relieve the holding charge.

#### 2. Calibration of High Pressure Cutout

- Calibrate the HPC to cut out when 15 PSIG is exceeded. The cut in value is approximately 10 PSIG. CUT OUT \_\_\_\_\_ PSIG, CUT IN \_\_\_\_\_ PSIG.

#### 3. Meggar the Motor (500 volt Meggar)

- Compressor motor Megohms – refer to temp/resistance chart for acceptable values. Remove surge suppressors before Megging. Never Meg test with the unit in a vacuum.

T1 to Earth _____	T4 to Earth _____	T1 to T2 _____	T1 to T4 _____
T2 to Earth _____	T5 to Earth _____	T1 to T3 _____	T2 to T5 _____
T3 to Earth _____	T6 to Earth _____	T2 to T3 _____	T3 to T6 _____

#### 4. Evacuation

- Connect the vacuum pump to start evacuation. Use a 2-stage pump with at least 5 CFM capacity. Connect to the evaporator-charging valve with a hose no smaller than 3/4 inch ID.

#### 5. Condenser

- Isolation and flow valves installed.
- Calibrated thermometers and pressure gauges installed in/out condenser on machine side of any valve or elbow.
- If condenser pump controlled by UCP2, is field wiring correct and complete?
- Condenser pump(s) run, system and strainers properly cleaned and/or flushed.
- Condenser water strainer in close proximity to entering connection of condenser.
- Provisions installed to properly maintain water treatment additives.
- Initial water treatment added to system.
- Flow or differential pressure switch installed and wired in series with auxiliary of pump motor starter. Operation of circuit verified.
- Condenser water flow balance. Ft H2O PD design \_\_\_\_\_, Ft H2O actual \_\_\_\_\_  
GPM design \_\_\_\_\_, GPM actual \_\_\_\_\_

# Forms

---

## 6. Evaporator

- \_\_\_\_ PSIG. Must be positive pressure or leak test must be done.
- Calibrated thermometers and pressure gauges installed in/out of evaporator on machine side of any valve or elbow.
- If evaporator pump controlled by UCP2, is field wiring correct and complete?
- Evaporator pump(s) run 24 hrs. System and strainers properly cleaned and/or flushed.
- Evaporator water strainer in close proximity to entering connection of evaporator.
- Provisions installed to properly maintain water treatment additives.
- Initial water treatment added to system.
- Flow or differential pressure switch installed and wired in series with auxiliary of pump motor starter. Operation of circuit verified.
- Evaporator water flow balanced. Ft H2P PD design\_\_\_\_, Ft H2O PD actual\_\_\_\_  
GPM design\_\_\_\_ GPM actual\_\_\_\_

## 7. Electrical and Controls

### a. Motor starter panel

- All terminals tightened.
- Wiring free from abrasion, kinks and sharp corners.
- Contactors and relays have freedom of movement.
- All contacts are free of corrosion or dirt. Panel is free of dust, debris etc.
- Check the ratio of the current transformers. Record the part #s on the start-up log.
- Use only twisted shielded pair for the IPC circuit between the starter and the UCP2 on remote starters. Recommended wire is Belden 8760, 18 AWG. Polarity is critical.
- The low voltage IPC link (< 30 volts) must be in a separate conduit from the 115-volt wiring.
- IPC link routing within the starter panel must stay a minimum of 6 inches from higher voltages.
- Remote starter to UCP2 connections are complete and comply with Trane requirements.
- Check the correctness of the power connections from the starter to the motor.
- Check the wiring to the starter for size, voltage and correct phase rotation (A-L1, B-L2, and C-L3).
- Check the equal phase representation in each power-wiring conduit.

# Forms

---

## b. Control panel

- All terminals tightened.
- Wires free from abrasion, kinks and sharp corners.
- Low voltage wires are isolated from high voltage wires.
- Panel is free of debris, dust etc.
- "Power up" the control panel.
  1. Starter disconnect locked open.
  2. Fuse 2F4 must be removed from the starter.'
  3. Connect auxiliary 115VAC-power cord to Terminals 1TB1-1 and 1TB1-2 in the control panel. **MAKE SURE OF THE POLARITY. THE 'HOT' SIDE MUST BE CONNECTED TO TERMINAL 1TB1-1 AND THE 'NEUTRAL' SIDE TO 1TB1-2.**
  4. Plug in cord to 115VAC-power source. Control panel is now energized.
- Record the settings found in the Operator Settings, Service Settings Field Start-up Group, and Machine Configuration Menus in the UCP2.
- Using the CVHE Operation and Maintenance manual and the order specification, double check and reset, if required, the settings of Current Overload Setting #1 and Current Overload Setting #2 found in the Machine Configuration menu of the UCP2.

**NOTE: DO NOT FORGET TO ADJUST THE RLA RATING TO MATCH THE ACTUAL JOBSITE VOLTAGE IF IT DIFFERS FROM THE DESIGN VOLTAGE.**

- If Evaporator and/or condenser water pumps are controlled by the UCP2, use the Service Test Menu of the UCP2 to manually start and test the control of the pumps.
- Check the setting of the oil pressure-regulating valve.
  1. Use the Service Tests menu of the UCP2 to manually start the oil pump.
  2. Proceed to the Compressor Report menu of the UCP2 and observe the Differential Oil Pressure
  3. Adjust the oil pressure-regulating valve to maintain 12 to 18 psid. The oil pressure-regulating valve may require adjustment as the unit is started.
  4. This procedure also checks to ensure correct sensing of oil pressure. The Oil Pressure Cutout setting is a non-adjustable 9 psid within the logic of the UCP2.
  5. Return Oil Pump control to 'auto'.
- Check vane operator and vanes.
  1. Use the Service Tests menu of the UCP2 to manually override the vane control.
  2. Enter targets from 0% to 100% and observe vane operation. At minimum and maximum travel the operator should not exert any force on the vane assembly, adjust as required.
  3. Vane movement is smooth to open/close.
  4. Vane movement is reported back to the UCP2.
  5. Return Vane control to 'auto'.

# Forms

---

- Dry run the starter
  1. Make sure the starter disconnect is safely locked open.
  2. Use the Service Tests menu of the UCP2 to initiate the Starter Dry Run.
  3. Observe correct operation of starter contactors.
  4. Observe correct operation of transition complete signal (if required).
  5. Disable Starter Dry Run when complete.
  
- Disconnect and remove the temporary power cord.

## B. Preparation for Start-up.

### 1. Evacuation and charging

Evacuation leak test. When vacuum has been drawn down to .5-1 MM Hg, (500-1000 microns) secure the vacuum pump. Wait for 12 hours for a valid vacuum leak test. If the rise in vacuum is less .5 mm (500 microns) per 12 hours, start-up may proceed.

Charge refrigerant. **MAKE SURE THE CHILLED WATER IS FLOWING THROUGH THE EVAPORATOR.** Charge the prescribed amount of refrigerant through the liquid charging valve at the liquid inlet to the evaporator. Check that all drums contain a full amount of refrigerant. Amount charged \_\_\_\_\_ lbs/kg.

### 2. Electrical

Disconnect all temporary power cords, replace all fuses, connect motor leads, make final electrical inspection.

Power up the motor starter. Check for control voltage at control panel terminals 1TB1-1 and 1TB1-2. \_\_\_\_\_ volts.

Check current to the oil sump heater. \_\_\_\_\_ amperes

As the oil heats up, finish any operations not yet completed in preparation for starting the unit.

## C. Chiller Start-up

### 1. Make all preliminary checks.

Oil temp, oil level, chilled water flow, chilled water load available (cooling units on) etc.

### 2. Start the unit.

If the phase rotation of the electrical power has not been positively confirmed, the actual rotation of the motor must be checked. Observe the rotation of the motor shaft through the sight glass on the end of the motor at the moment of start-up. Rotation must be CLOCKWISE. If the phase sequence is incorrect, confirmed by observation of the Phase Reversal diagnostic on the UCP2, then L1 and L3 power leads to the starter must be reversed.

As the unit starts and runs, observe closely all operating conditions.

Adjust the oil pressure regulator if necessary to 18 to 22 psi net.

# Forms

---

- In the Operator Settings menu of the UCP2, place the Purge Operating Mode to 'on' to allow the removal of non-condensables. It may also be necessary to increase the length of the Purge Service Override timer found in the Field Startup Group menu.
  - After the unit has the system down to design leaving chilled water temp and is under control, and the purge is no longer relieving non-condensables, begin taking the start-up test log. Log the unit a minimum of 3 times at 15-minute intervals.
  - In the Operator Settings menu of the UCP2, return the purge-operating mode to 'Adaptive'.
  - When the logging is complete, shut the chiller down. Allow the unit to sit idle for 5-10 minutes. Attach a piece of clear plastic hose between the ½ inch valve at the bottom of the evaporator and the ¼ inch valve near the top of the evaporator. Open the valves and record or mark permanently the refrigerant level in the hose. Record this level – it is very important! At some later time, the refrigerant charge can be easily checked and verified.
  - Restart the chiller and carefully observe the starting and loading sequence.
3. Instructions to the Chiller Operator.
- Instructions for starting, operating, and shutting down.
  - Instructions for logging the unit.
  - Instructions for periodic maintenance.

**D. After 2 weeks of operation. (International Units Only)**

1. Remove the water box covers on both the evaporator and condenser. Mechanically brush clean all the tubes. This is to assure there is no debris blocking any of the tubes. A piece of debris partially blocking a tube may cause that tube to fail prematurely.
2. Replace the oil filter with the spare oil filter included in the control panel at time of shipment.

**E. Comments and/or Recommendations:**

---

---

---

---

---

---

---

---

---

Service Technician

Signature

Date

# Forms



## Start-Up Test Log Water Cooled CenTraVac® With UCP2 Control Panel

Job Name _____		Job Location _____	
Model # _____		Serial # _____ Start Date _____	
Sales Order # _____ Ship Date _____		Job Elevation (Ft. above sea level) _____	
<b>STARTER DATA:</b> Manufacturer _____ Type _____ (Star-Delta, X-Line, AutoTrans, Primary Reactor, Solid-State, Etc.) Vendor ID #/Model # _____ Volts _____ Amps _____ Hz _____		<b>START-UP ONLY</b> <b>CHILLER CONDITION:</b> On Arrival: <input type="checkbox"/> Machine Vacuum = _____ mm (CVHE/F) Or <input type="checkbox"/> Machine Pressure = _____ psig (CVHE/F or RTHB) At Start-Up: <input type="checkbox"/> Machine Vacuum = _____ mm Or <input type="checkbox"/> Machine Pressure = _____ psig	
<b>MOTOR DATA:</b> Manufacturer _____ Type and Frame _____ Drawing # _____ Serial # _____		Complete If Pressure Test Is Required: <input type="checkbox"/> Vacuum after Leak Check = _____ mm <input type="checkbox"/> Standing Vacuum Test = _____ mm Rise in _____ Hours	
<b>COMPRESSOR DATA:</b> (RTHB Units Only) Model # _____ Serial # _____		<b>UNIT REFRIGERANT CHARGE:</b> _____ lbs. of R- _____	
<b>NAMEPLATE DATA:</b> RLA _____ KW _____ VOLTS _____ HZ _____		<b>HIGH PRESSURE CUTOUT (3S1):</b> <input type="checkbox"/> Cut-In = _____ psig <input type="checkbox"/> Cutout = _____ psig	
<b>DESIGN DATA:</b> (From Design Specification) RLA _____ KW _____ VOLTS _____ HZ _____		<b>SUMMARY OF UNIT OPTIONS INSTALLED:</b> <input type="checkbox"/> Tracer Communications Interface <input type="checkbox"/> Remote Clear Language Display Module <input type="checkbox"/> Options Module <input type="checkbox"/> Outdoor Air Sensor <input type="checkbox"/> Entering Condenser Limit Control <input type="checkbox"/> Heat Recovery/Aux. Condenser <input type="checkbox"/> Free Cooling Control <input type="checkbox"/> Hot Gas Bypass Control <input type="checkbox"/> Ice Making Control <input type="checkbox"/> Monitoring Package <input type="checkbox"/> Bearing Oil Temp. Sensors <input type="checkbox"/> Discharge Temp. Sensor <input type="checkbox"/> Compressor Phase Volt Sensors <input type="checkbox"/> Other _____	
<b>HEAT RECOVERY PERFORMANCE:</b> RLA _____ KW _____ VOLTS _____ HZ _____			
<b>CURRENT TRANSFORMER</b> <b>PART NUMBERS:</b> ("X" Code and 2-Digit Extension) Primary CT's: X _____ - _____ X _____ - _____ X _____ - _____ Secondary CT's: X _____ - _____ X _____ - _____ X _____ - _____ (Note: Secondary CT's are used only on remote starters "by others" and high voltage applications)			
Also complete the Commissioning Checklist, Record Sheet and Start-Up/Operation Log			

1-27.90-5—(399)  
Supersedes 1-27.90-5—(296)

# Forms

Sales Order # _____		Location _____		
Model # _____		Serial # _____		
<b>DESIGN CONDITIONS**</b>	<b>CHILLER REPORT:</b>	1ST READING	2ND READING	3RD READING
**From design specification	CHILLER OPERATING MODE			
DEG F _____ →	ACTIVE CHILLED WATER SETPOINT			
DEG F _____ →	EVAP LEAVING WATER TEMP			
DEG F _____ →	EVAP ENTERING WATER TEMP			
DEG F _____ →	CONDENSER ENTERING WATER			
DEG F _____ →	CONDENSER LEAVING WATER			
	ACTIVE CURRENT LIMIT SETPOINT			
GPM _____ →	EVAPORATOR WATER FLOW			
GPM _____ →	CONDENSER WATER FLOW			
	OUTDOOR AIR TEMPERATURE			
	<b>REFRIGERANT REPORT:</b>			
	EVAP REFRIGERANT PRESSURE			
	COND REFRIGERANT PRESSURE			
	SATURATED COND TEMP			
	SATURATED EVAP REFRIGERANT TEMP			
	<b>COMPRESSOR REPORT:</b>			
	COMPRESSOR DISCHARGE TEMP (OPT.)			
(12 TO 18 PSID) _____ →	DIFFERENTIAL OIL PRESSURE			
(UNIT 'ON' 30 F ABOVE SAT. EVAP. TEMP. TO 150 F)	OIL TANK TEMPERATURE			
	DISCHARGE OIL PRESSURE			
	OIL TANK PRESSURE			
DESIGN RLA _____ →	COMPRESSOR PHASE AMPS    A			
DESIGN KW _____ →	COMPRESSOR PHASE AMPS    B			
	COMPRESSOR PHASE AMPS    C			
DESIGN VOLTS _____ →	COMPRESSOR VOLTAGE        AB			
DESIGN HZ _____ →	COMPRESSOR VOLTAGE        BC			
	COMPRESSOR VOLTAGE        CA			
	COMPRESSOR WINDING TEMP    W1			
	COMPRESSOR WINDING TEMP    W2			
	COMPRESSOR WINDING TEMP    W3			
	COMPRESSOR STARTS			
	COMPRESSOR RUNNING TIME			
	BEARING TEMPERATURE 1			
	BEARING TEMPERATURE 2			
	OPERATING OIL LEVEL			
	VIBRATION READINGS	HORIZONTAL		
	AT THRUST BEARING	VERTICAL		
	END (OPT.)	AXIAL		
FRONT PANEL CHILLED WATER SETPOINT: _____		DESIGN DELTA TEMP SETPOINT: _____		
LEAVING WATER TEMP CUTOUT SETPOINT: _____		LOW REFRIGERANT TEMP CUTOUT SETPOINT: _____		
CURRENT OVERLOAD SETTING #1: _____		CURRENT OVERLOAD SETTING #2: _____		
<b>EVAPORATOR WATER PRESSURE DROP:</b>	<b>CONDENSER WATER PRESSURE DROP:</b>	<b>PURGE</b>		
DESIGN PSIG: _____ GPM: _____	DESIGN PSIG: _____ GPM: _____	RUN HRS _____		
ACTUAL PSIG: _____ GPM: _____	ACTUAL PSIG: _____ GPM: _____	SUC TEMP _____ DEG F		
<b>UNIT MOUNTED REFRIGERANT MONITOR READOUT (OPT.)</b>				
SINGLE POINT _____ 4 CHANNEL SCANNER: 1. _____ 2. _____ 3. _____ 4. _____				
<b>MOTOR INSULATION MEG OHMS: @ Megger Voltage</b>			<b>TECHNICIAN:</b>	
TER. 1 TO GND _____	TER. 1-2 _____	TER. 1-4 _____	_____	
TER. 2 TO GND _____	TER. 1-3 _____	TER. 2-5 _____	<b>OWNER'S REP.:</b>	
TER. 3 TO GND _____	TER. 2-3 _____	TER. 3-6 _____	_____	
			<b>DATE:</b>	
<b>ACTIVE AND HISTORIC DIAGNOSTICS:</b> _____				
_____				
<b>COMMENTS:</b> _____				
_____				

Also Complete CVHE/F UCP2 Commissioning Checklist and Record Sheet

1-27.90-5—(Back)—(399)  
Supersedes 1-27.90-5—(Back)—(296)

# Forms

---

## CentraVac® Adaptive Frequency Drive™ Startup and Operating Log

Sales Order #	Location
Model #	Drive Model #
Serial #	Drive Serial #

Prestart Checklist	✓ When Completed	Comments
Motor is Grounded		
Verified Drive Parameter Settings		
Drive Chassis Grounded		
Control Wiring & Drive Connections Tight		
Water Pump Rotation		
Distilled Water in Primary Water Loop		
Corrosion Inhibitor Installed		

### UCP2 Control Settings

Name	Default	Setting
Starter Type	AFDB	
Condenser Pressure Sensor Option	Installed	
AF Adjustable Speed Control Algorithm Enable	Enable	
AF Leaving Water Standard Deviation	1.0	
AF Pressure Coefficient Constant	800	
AF Re-optimization Factor	0.30	
AF Re-optimization Timer	24	
AF Boundary Pressure Coefficient Y Intercept	0.40	
AF Boundary Pressure Coefficient Y Intercept Maximum	2.00	
AF Pressure Error Deadband	0.030	
AF Proportional Speed Gain	50	

### (P) AFDB Parameter Settings: Record Number and Setting

Number	Setting	Number	Setting
1. P000		11. P010	
2. P001		12. P011	
3. P002		13. P012	
4. P003		14. P013	
5. P004		15. P014	
6. P005		16. P015	
7. P006		17. P016	
8. P007		18. P017	
9. P008		19. P018	
10. P009		20. P019	

# Forms

---

<b>(P) AFDB Parameter Settings: Record Number and Setting</b>			
<b>Number</b>	<b>Setting</b>	<b>Number</b>	<b>Setting</b>
21. P020		57. P056	
22. P021		58. P057	
23. P022		59. P058	
24. P023		60. P059	
25. P024		61. P060	
26. P025		62. P061	
27. P026		63. P062	
28. P027		64. P063	
29. P028		65. P064	
30. P029		66. P065	
31. P030		67. P066	
32. P031		68. P067	
33. P032		69. P068	
34. P033		70. P069	
35. P034		71. P070	
36. P035		72. P071	
37. P036		73. P072	
38. P037		74. P073	
39. P038		75. P074	
40. P039		76. P075	
41. P040		77. P076	
42. P041		78. P077	
43. P042		79. P078	
44. P043		80. P079	
45. P044		81. P080	
46. P045		82. P081	
47. P046		83. P082	
48. P047		84. P083	
49. P048		85. P084	
50. P049		86. P085	
51. P050		87. P086	
52. P051		88. P087	
53. P052		89. P088	
54. P053		90. P089	
55. P054		91. P090	
56. P055		92. P091	

# Forms

---

<b>(U) AFDB Parameter Settings: Record Number and Setting</b>			
Number	Setting	Number	Setting
1. U000		26. U025	
2. U001		27. U026	
3. U002		28. U027	
4. U003		29. U028	
5. U004		30. U029	
6. U005		31. U030	
7. U006		32. U031	
8. U007		33. U032	
9. U008		34. U033	
10. U009		35. U034	
11. U010		36. U035	
12. U011		37. U036	
13. U012		38. U037	
14. U013		39. U038	
15. U014		40. U039	
16. U015		41. U040	
17. U016		42. U041	
18. U017		43. U042	
19. U018		44. U043	
20. U019		45. U044	
21. U020		46. U045	
22. U021		47. U046	
23. U022		48. U047	
24. U023		49. U048	
25. U024			

<b>(R) AFDB Parameter Settings: Record Number and Setting</b>			
Number	Setting	Number	Setting
1. R030			
2. R035			
3. R036			
4. R037			

# Forms



## START-UP PROCEDURES TRANE LIQUI-FLO VARIABLE FREQUENCY DRIVE PRE START-UP CHECKLIST AND SERVICE REQUEST

Use this form to check for proper installation of the Rockwell Automation Liqui-Flo VFD. For start-up service, please fax this completed form to: **Rockwell Automation – LaCrosse, WI FAX: 1-608-781-7182** to schedule start-up. Please allow three weeks to arrange for start-up services.

JOB LOCATION \_\_\_\_\_ INSTALLING CONTRACTOR \_\_\_\_\_  
STREET \_\_\_\_\_ CONTRACTOR CONTACT \_\_\_\_\_  
CITY \_\_\_\_\_ CONTACT PHONE \_\_\_\_\_

### PRE START-UP CHECKLIST

PRIOR TO ROCKWELL AUTOMATION BEING ON SITE, CONFIRM THAT THE FOLLOWING ACTIONS HAVE BEEN COMPLETED (OR WILL BE COMPLETED PRIOR TO THE SCHEDULED START-UP):

- |   | YES                      |
|---|--------------------------|
| 1. The Trane Liqui-Flo VFD is mounted and wired per the CVHE-OM-8 Operation & Maintenance manual and/or wiring diagram (if separately supplied).  | <input type="checkbox"/> |
| 2. The A-C primary line voltage is the proper voltage.  | <input type="checkbox"/> |
| 3. The Trane chiller is ready to start and operate under load conditions. All preliminary start-up checks have been completed as detailed in the appropriate Installation Operation Maintenance manual, such as (evacuation, charging, all wiring & electrical work, chiller and AFD control settings checked, etc...). | <input type="checkbox"/> |
| 4. The Personnel have been selected to assist the Rockwell Automation service representative with the operation of the equipment and the facility layout.   | <input type="checkbox"/> |

### REQUEST FOR SERVICE REPRESENTATIVE

I acknowledge that all four of the above items have been completed. I understand that if upon job inspection these requirements are not met, no start-up work will be performed and travel time and mileage will be charged at current hourly rates.

NAME \_\_\_\_\_ COMPANY \_\_\_\_\_  
PHONE \_\_\_\_\_ FAX \_\_\_\_\_  
DATE/TIME DESIRED \_\_\_\_\_ ALTERNATE DATE/TIME \_\_\_\_\_  
START-UP SERVICE COVERED BY P.O.# \_\_\_\_\_

