

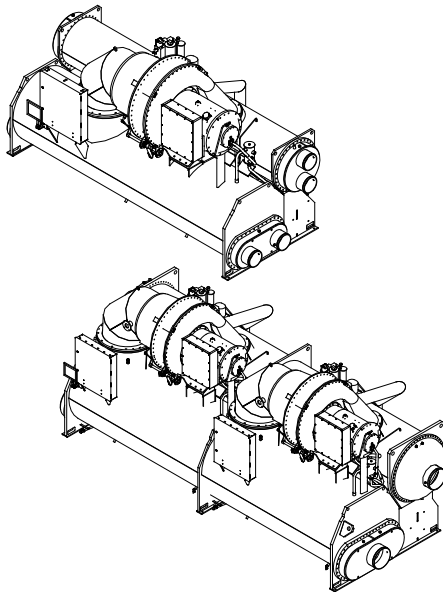

Installation Instructions

Disassembly and Reassembly Units Water-Cooled CenTraVac™ Chillers



50 Hz Models: CVHE, CVHG, CDHG

60 Hz Models: CVHE, CVHF, CDHF

X39640718070

SAFETY WARNING

Only qualified personnel should install and service the equipment. The installation, starting up, and servicing of heating, ventilating, and air-conditioning equipment can be hazardous and requires specific knowledge and training. Improperly installed, adjusted or altered equipment by an unqualified person could result in death or serious injury. When working on the equipment, observe all precautions in the literature and on the tags, stickers, and labels that are attached to the equipment.



Warnings, Cautions, and Notices

Warnings, Cautions, and Notices. Note that warnings, cautions, and notices appear at appropriate intervals throughout this manual. Warnings are provided to alert installing contractors to potential hazards that could result in personal injury or death. Cautions are designed to alert personnel to hazardous situations that could result in personal injury, while notices indicate a situation that could result in equipment or property-damage-only accidents.

Your personal safety and the proper operation of this machine depend upon the strict observance of these precautions.

ATTENTION: Warnings, Cautions, and Notices appear at appropriate sections throughout this literature. Read these carefully:

⚠ WARNING Indicates a potentially hazardous situation which, if not avoided, could result in death or serious injury.

⚠ CAUTION Indicates a potentially hazardous situation which, if not avoided, could result in minor or moderate injury. It could also be used to alert against unsafe practices.

NOTICE: Indicates a situation that could result in equipment or property-damage only accidents.

Important Environmental Concerns!

Scientific research has shown that certain man-made chemicals can affect the earth's naturally occurring stratospheric ozone layer when released to the atmosphere. In particular, several of the identified chemicals that may affect the ozone layer are refrigerants that contain Chlorine, Fluorine and Carbon (CFCs) and those containing Hydrogen, Chlorine, Fluorine and Carbon (HCFCs). Not all refrigerants containing these compounds have the same potential impact to the environment. Trane advocates the responsible handling of all refrigerants-including industry replacements for CFCs such as HCFCs and HFCs.

Responsible Refrigerant Practices!

Trane believes that responsible refrigerant practices are important to the environment, our customers, and the air conditioning industry. All technicians who handle refrigerants must be certified. The Federal Clean Air Act (Section 608) sets forth the requirements for handling, reclaiming, recovering and recycling of certain refrigerants and the equipment that is used in these service procedures. In addition, some states or municipalities may have additional requirements that must also be adhered to for responsible management of refrigerants. Know the applicable laws and follow them.

⚠ WARNING

Refrigerant under Positive Pressure!

System contains oil and refrigerant and may be under positive pressure. Recover refrigerant to relieve pressure before opening the system. See unit nameplate for refrigerant type. Do not use non-approved refrigerants, refrigerant substitutes, or refrigerant additives. Failure to recover refrigerant to relieve pressure or the use of non-approved refrigerants, refrigerant substitutes, or refrigerant additives could result in an explosion which could result in death or serious injury or equipment damage.

⚠ WARNING

Personal Protective Equipment (PPE) Required!

Installing/servicing this unit could result in exposure to electrical, mechanical and chemical hazards.

- Before installing/servicing this unit, technicians **MUST** put on all PPE required for the work being undertaken. **ALWAYS** refer to appropriate MSDS sheets and OSHA guidelines for proper PPE.
- When working with or around hazardous chemicals, **ALWAYS** refer to the appropriate MSDS sheets and OSHA guidelines for information on allowable personal exposure levels, proper respiratory protection and handling instructions.
- If there is a risk of arc or flash, technicians **MUST** put on all PPE in accordance with NFPA 70E or other country-specific requirements for arc flash protection, **PRIOR** to servicing the unit.

Failure to follow instructions could result in death or serious injury.

⚠ WARNING

Proper Field Wiring and Grounding Required!

All field wiring **MUST** be performed by qualified personnel. Improperly installed and grounded field wiring poses **FIRE** and **ELECTROCUTION** hazards. To avoid these hazards, you **MUST** follow requirements for field wiring installation and grounding as described in NEC and your local/state electrical codes. Failure to follow code could result in death or serious injury.

Factory Warranty Information

Compliance with the following is required to preserve the factory warranty:

All Unit Installations

Startup **MUST** be performed by Trane, or an authorized agent of Trane, to **VALIDATE** this WARRANTY. Contractor must provide a two-week startup notification to Trane (or an agent of Trane specifically authorized to perform startup).

Additional Requirements for Units Requiring Disassembly and Reassembly

When a new chiller is shipped and received from our Trane manufacturing location and, for any reason, it requires disassembly or partial disassembly, and reassembly—which could include but is not limited to the evaporator, condenser, control panel, compressor/motor, economizer, purge, factory-mounted starter or any other components originally attached to the fully assembled unit—compliance with the following is required to preserve the factory warranty:

- Trane, or an agent of Trane specifically authorized to perform start-up and warranty of Trane® products, will perform or have direct on-site technical supervision of the disassembly and reassembly work.
- The installing contractor must notify Trane—or an agent of Trane specifically authorized to perform startup and warranty of Trane® products—two weeks in advance of the scheduled disassembly work to coordinate the disassembly and reassembly work.
- Start-up must be performed by Trane or an agent of Trane specifically authorized to perform startup and warranty of Trane® products.

Trane, or an agent of Trane specifically authorized to perform start-up and warranty of Trane® products, will provide qualified personnel and standard hand tools to perform the disassembly and reassembly work at a location specified by the contractor. The contractor shall provide the rigging equipment such as chain falls, gantries, cranes, forklifts, etc. necessary for the disassembly and reassembly work and the required qualified personnel to operate the necessary rigging equipment.

Trademarks

CenTraVac, Duplex, Tracer AdaptiView, Trane, and the Trane logo are trademarks or registered trademarks of Trane in the United States and other countries. All trademarks referenced in this document are the trademarks of their respective owners.

CRC is a registered trademark of CRC Industries; GORE-TEX is a registered trademark of W. L. Gore & Associates; Loctite is a registered trademark of Henkel Corporation; Stay Brite is a registered trademark of J. W. Harris Co., Inc.



Table of Contents

- General Information 5
 - Contractor Responsibilities 5
 - Metric Conversions 5
 - Device Descriptions 5
- Dimensions and Weights 6
 - Dimensions 6
 - Single Compressor Chillers: CVHE, CVHF, CVHG 6
 - Duplex Chillers: CDHF, CDHG 13
 - Weights 16
 - Single Compressor and Duplex Chillers: CVHE, CVHF, CVHG, CDHF, CDHG 16
- Compressor/Motor Disassembly 18
 - Remove Nitrogen Charge 18
 - Introduction 18
 - Wiring Disassembly 18
 - Purge Unit Removal 18
 - Compressor Motor Assembly Removal .. 19
 - Compressor Motor Mount Disassembly . 23
 - Economizer Removal 23
 - Tracer AdaptiView Display Arm Removal 24
 - Control Panel Removal 24
 - Unit-mounted Starter Removal 25
 - Condenser/Evaporator Disassembly 25
 - Disassembly of Chillers with Options 26
 - Heat Recovery 26
 - Free Cooling 27
- Compressor/Motor Reassembly 28
 - Brazing 29
 - Final Installation Procedures 30

General Information

The information and procedures in this document are to facilitate unit disassembly *for clearance and access reasons during the installation process.*

The understanding is that the chiller has what is referred to as the “*compressor doweling option*” or “*separable shell option*” (which includes compressor doweling). Compressor doweling sets up the compressor for removal. The separable shell option includes a bolt-together design between the evaporator and condenser and allows the shells to be separated in the field.

Important: These procedures do NOT apply to units that have been installed and electrical supply wiring has been completed.

Contractor Responsibilities

- Handle/lift and rig equipment
- Protect all internal components from exposure to elements, which could contaminate or corrode chiller components.
- Chiller reassembly
- Replace all gaskets with new gaskets or O-rings and sealing compound.¹
- Change the compressor oil¹
- Evacuate the chiller under 1000 microns¹
- Recharge the chiller with dry nitrogen to 5 psig¹
- Replace and/or repair insulation
- Reconnect electrical connections
- Spot paint the chiller if necessary

Metric Conversions

ft·lb x 1.3558 = Newton-meter

lb x 0.4536 = kg

in x 25.4000 = mm

Device Descriptions

- CPTF = Optional control power transformer (industrial units only)
- FRCL = Optional control power transformer (industrial units only)
- HGBP = Optional hot gas bypass
- INDP = Optional industrial control package
- SMP = Optional supplemental motor protection (industrial unit only)
- UAFD = Unit mounted LiquiFlo 2 Adaptive frequency drive
- UATR = Unit mounted medium voltage auto-transformer
- UPIR = Unit mounted medium voltage primary reactor
- UXL = Unit mounted medium voltage across the line starter
- USID = Unit mounted low voltage solid state starter
- USTR = Unit mounted low voltage Wye-delta starter

¹ The contractor should assist a qualified Trane Technician with this responsibility.



Dimensions and Weights

Dimensions

Single Compressor Chillers: CVHE, CVHF, CVHG

Table 1. For Figure 1, p. 9 and Figure 2, p. 10: Dimension data for CVHE, CVHF, and CVHG

Model	NTON	Shell Size	Comp Size	A	B	C	D	E	F	G	H	J	K	L	M
CVHE	190–270	032	320	66.7	53.1	N/A	N/A	84.9	49.2	49.7	70.8	45.5	53.1	37.9	34.5
	230–320	050	320	75.4	53.6	N/A	N/A	73.4	49.2	52.4	77.1	45.5	52.5	43.9	38.7
	300–420	050	500	73.7	52.7	N/A	N/A	87.8	51.7	54.4	77.1	45.5	52.5	42.3	38.7
	360–500	080	500	93.5	77.1	101.3	42.0	87.8	51.7	58.6	93.8	45.5	62.2	63.5	44.3
	300–450	050/080	500	84.1	66.0	90.4	42.0	87.8	51.7	58.6	82.7	46.0	54.9	49.32	41.3
CVHF	350–570	050	570	75.4	52.7	N/A	N/A	78.3	51.3	54.4	77.1	45.5	52.5	43.9	38.7
		050/080	480	84.1	64.6	90.4	42.0	78.3	51.3	59.1	82.7	46.0	54.9	49.32	41.3
		080	570	93.5	75.7	101.3	42.0	78.3	51.3	59.1	93.8	45.5	62.2	63.5	44.3
	620–870	080	870	93.5	75.0	101.3	42.0	81.2	59.7	72.6	93.8	45.5	63.9	63.5	44.3
		080/142	870	101.3	79.4	107.5	(a)	81.3	59.7	73.2	102.0	45.5	67.9	63.59	46.0
		142	870	120.9	80.4	121.9	(a)	81.2	59.7	72.6	110.9	46.9	64.2	76.5	50.5
	650–910	080	910	93.5 ^(b)	76.5	101.3	42.0	81.2	54.6	66.7	93.8	45.5	63.9	63.5	44.3
		080/142	910	101.3	79.4	107.5	(a)	81.3	54.6	66.7	102.0	45.5	64.6	63.59	46.0
		142	910	98.1	83.0	111.0	(a)	81.2	54.6	66.7	105.5	46.9	69.8	62.5	46.0
	1070–1300	080/142	1300	102.2	80.5	107.5	(a)	80.5	59.1	72.4	102.0	45.5	65.7	63.59	46.0
		142	1300	120.9	80.4	121.9	(a)	80.2	59.7	72.6	110.9	46.9	64.2	76.5	50.5
		210	1300	106.5	94.5	116.0	(a)	80.2	59.7	72.6	116.4	50.5	84.5	68.2	50.5
		250	1300	120.9	98.6	121.9	(a)	80.2	59.7	72.6	116.4	54.5	84.5	76.7	56.6
	1470–1720	210	1720	106.5	92.8	116.0	(a)	91.2	63.1	75.6	110.9	50.5	78.2	68.2	50.5
		250	1720	120.9	96.9	121.9	(a)	91.2	63.1	75.6	116.4	54.5	84.4	76.7	56.6
CVHG	480–565	050	565	75.4	52.6	N/A	N/A	93.8	53.0	57.5	77.1	45.5	52.5	43.9	38.7
		080	565	93.5	74.6	101.3	42.0	94.3	53.0	62.8	93.8	45.5	62.2	63.5	44.3
		050/080	565	82.6 ^(c)	63.4	90.2	42.0	94.5	52.9	62.8	82.7	46.0	57.6	49.32	40.0
	670–780	080	780	93.5	76.5	101.3	42.0	94.0	54.3	66.6	93.8	45.5	63.9	63.5	44.3
		080/142	780	101.3	79.4	107.5	(a)	91.9	54.3	66.6	102.0	45.5	66.8	63.59	46.0
		142	780	98.1	83.0	111.0	(a)	94.0	54.3	66.6	105.5	46.9	69.8	62.5	46.0
	920–1067	080/142	920	102.2	82.0	107.5	(a)	90.9	54.6	68.7	102.0	45.5	64.3	63.59	46.0
		142	920	98.1	84.0	111.0	(a)	93.2	54.3	68.0	105.5	46.9	69.8	62.5	46.0
		210	920	106.5	96.0	116.0	(a)	93.2	54.3	68.0	110.9	50.5	81.5	68.2	50.5
	1100	080/142	1100	102.2	80.5	107.5	(a)	93.2	59.1	72.4	102.0	45.5	65.7	63.59	46.0
		142	1100	98.8	80.4	107.4	(a)	93.2	59.7	71.8	101.9	46.9	62.0	62.3	46.0
		210	1100	106.5	94.5	116.0	(a)	93.2	59.7	72.6	110.9	50.5	78.2	68.2	50.5

Note: All dimensions are in inches (± 0.5 inch).

- (a) Does not extend beyond the condenser tube unit.
- (b) Add 1 in. to overall width for compressor.
- (c) Add 4 in. to overall width for compressor.

Table 2. For Figure 1, p. 9 and Figure 2, p. 10: Dimension data for CVHE, CVHF, and CVHG

Model	NTON	Shell Size	Comp Size	N	P	R	S	T	U	V	Short Long		USID	UATR	
											W	W	USTR	UPIR	
														UXL	
CVHE	190–270	032	320	60.1	81.9	29.7	17.0	26.5	68.6	93.9	47.0	47.0	N/A	79.8	(a)
	230–320	050	320	64.6	81.9	29.7	17.0	23.4	80.5	98.4	63.4	54.9	N/A	94.1	N/A
	300–420	050	500	62.8	81.9	29.8	17.3	26.5	80.5	98.7	63.4	54.9	N/A	92.5	N/A
	360–500	080	500	79.0	81.9	29.8	17.3	26.5	97.1	114.9	80.8	80.8	66.3	(a)	(a)
	300–450	050/080	500	68.1	82.3	29.0	16.3	26.5	90.1	103.8	N/A	N/A	N/A	(a)	(a)

Note: All dimensions are in inches (± 0.5 inch).

Dimensions and Weights

Table 2. For Figure 1, p. 9 and Figure 2, p. 10: Dimension data for CVHE, CVHF, and CVHG (continued)

Model	NTON	Shell Size	Comp Size	N	P	R	S	T	U	V	W	W	X	UATR	
														USID USTR	UPIR UXL
CVHF	350-570	050	570	64.3	81.9	29.0	16.3	26.5	80.5	100.0	60.7	54.9	N/A	92.7	N/A
		050/080	480	68.1	82.3	29.0	16.3	26.5	90.1	103.7	N/A	N/A	N/A	(a)	(a)
		080	570	79.0	81.9	29.0	16.3	26.5	97.1	114.9	75.0	75.0	66.3	(a)	(a)
	620-870	080	870	75.7	81.9	30.5	17.8	26.5	97.1	117.1	82.4	82.4	63.9	(a)	(a)
		080/142	870	79.0	81.8	N/A	18.5	29.0	120.9	121.6	N/A	N/A	72.7	(a)	(a)
		142	870	82.1	83.3	30.5	17.8	26.5	117.4	121.5	78.1	78.1	72.7	(a)	(a)
	650-910	080	910	75.7	81.9	30.5	17.8	29.0	97.1	114.9	82.4	82.4	63.9	(a)	(a)
		080/142	910	79.0	81.8	N/A	18.5	29.0	120.9	117.8	N/A	N/A	72.7	(a)	(a)
		142	910	82.1	83.3	30.5	17.8	29.0	115.4	121.3	84.4	84.4	72.7	(a)	(a)
	1070-1300	080/142	1300	80.5	81.8	N/A	18.6	36.8	121.8	121.6	N/A	N/A	72.7	(a)	(a)
		142	1300	93.8	83.3	N/A	21.1	36.8	117.4	121.5	78.1	78.1	72.7	(a)	(a)
		210	1300	93.8	86.9	N/A	21.1	36.8	124.7	135.2	87.2	87.2	82.4	(a)	(a)
		250	1300	97.9	90.9	N/A	18.6	36.8	137.2	139.4	N/A	N/A	82.7	140.7	(b)
	1470-1720	210	1720	92.6	86.9	N/A	25.8	33.3	124.7	137.2	92.9	92.9	76.4	(a)	(a)
		250	1720	96.8	90.9	N/A	23.3	33.3	137.2	141.4	N/A	N/A	82.7	140.7	(b)
CVHG	480-565	050	565	66.4	81.9	32.4	19.9	26.5	80.5	103.0	63.4	54.9	N/A	93.3	N/A
		050/080	565	68.4	82.3	32.4	19.9	29.0	91.4	104.7	N/A	N/A	N/A	(a)	(a)
		080	565	79.2	81.9	33.6	21.2	29.0	98.1	115.8	81.7	81.7	N/A	(a)	(a)
	670-780	080	780	75.7	81.9	33.5	21.1	32.8	98.1	114.7	82.4	82.4	N/A	(a)	(a)
		080/142	780	79.0	81.8	N/A	18.5	32.8	120.9	117.6	N/A	N/A	72.7	(a)	(a)
		142	780	82.1	83.3	27.8	17.8	32.8	115.4	121.2	84.4	84.4	N/A	(a)	(a)
	920-1067	080/142	920	80.5	81.8	N/A	18.6	36.8	121.8	119.4	N/A	N/A	72.7	(a)	(a)
		142	920	82.1	83.3	28.0	18.0	36.8	115.4	121.2	84.4	84.4	N/A	(a)	(a)
		210	920	93.8	86.9	33.7	21.3	36.8	124.7	132.8	92.9	92.9	N/A	(a)	(a)
	1100	080/142	1100	80.5	81.8	N/A	18.6	36.8	121.8	121.6	N/A	N/A	72.7	(a)	(a)
		142	1100	80.1	83.3	28.0	18.0	36.8	117.4	121.5	78.1	78.1	72.7	(a)	(a)
		210	1100	93.8	86.9	33.7	21.3	36.8	124.7	135.2	87.2	87.2	82.4	(a)	(a)

Note: All dimensions are in inches (± 0.5 inch).

(a) See Table 5, p. 12.

(b) Does not extend beyond the main unit control panel.

Table 3. For Figure 1, p. 9 and Figure 2, p. 10: Dimension data for CVHE, CVHF, and CVHG

Model	NTON	Shell Size	Comp Size	UATR		405-608A		900-1210A		Z	AA	AB	AC	AD
				USID USTR	UPIR UXL	UAFD		UAFD						
				Y2	Y2	Y1	Y2	Y1	Y2					
CVHE	190-270	032	320	49.1	N/A	94.9	64.2	N/A	N/A	N/A	N/A	65.7	35.0	N/A
	230-320	050	320	57.5	N/A	101.2	64.6	N/A	N/A	N/A	N/A	78.1	41.5	N/A
	300-420	050	500	55.9	N/A	101.2	64.6	N/A	N/A	N/A	N/A	78.1	41.5	N/A
	360-500	080	500	(a)	(a)	110.6	77.0	N/A	N/A	45.3	(b)	88.2	54.6	N/A
	300-450	050/080	500	(a)	(a)	111.5	70.63	N/A	N/A	N/A	N/A	82.3	41.5	N/A

Note: All dimensions are in inches (± 0.5 inch).



Dimensions and Weights

Table 3. For Figure 1, p. 9 and Figure 2, p. 10: Dimension data for CVHE, CVHF, and CVHG (continued)

Model	NTON	Shell Size	Comp Size	UATR		405-608A		900-1210A		Z	AA	AB	AC	AD
				USID	UPIR	UAFD		UAFD						
				USTR	UXL	Y1	Y2	Y1	Y2					
CVHF	350-570	050	570	56.1	N/A	101.2	64.6	N/A	N/A	N/A	N/A	78.1	41.5	N/A
		050/080	480	(a)	(a)	111.5	70.63	N/A	N/A	N/A	N/A	82.3	41.5	N/A
		080	570	(a)	(a)	110.6	77.0	N/A	N/A	45.3	(b)	88.2	54.6	N/A
	620-870	080	870	(a)	(a)	125.8	92.2	133.3	99.8	42.9	4.8	88.2	54.6	4.8
		080/142	870	(a)	(a)	140.0	81.75	147.0	88.79	51.8	N/A	112.0	54.62	5.8
		142	870	(a)	(a)	132.4	77.5	146.0	91.0	51.8	1.8	113.9	59.0	4.6
	650-910	080	910	(a)	(a)	119.3	85.7	126.8	93.3	42.9	4.8	88.2	54.6	4.8
		080/142	910	(a)	(a)	132.7	75.33	146.2	88.87	51.8	N/A	112.0	54.62	5.8
		142	910	(a)	(a)	130.4	77.5	144.0	91.0	51.8	1.7	111.9	59.0	4.6
	1070-1300	080/142	1300	(a)	(a)	140.0	81.75	147.0	88.79	51.8	N/A	112.8	54.62	6.3
		142	1300	(a)	(a)	132.4	77.5	146.0	91.0	51.8	1.8	113.9	59.0	4.6
		210	1300	(a)	(a)	N/A	N/A	152.4	95.9	61.5	(b)	124.2	67.7	3.9
		250	1300	80.2	(b)	N/A	N/A	160.0	99.5	61.8	0.2	136.7	76.2	3.1
	1470-1720	210	1720	(a)	(a)	N/A	N/A	152.4	95.9	55.5	3.4	124.2	67.7	3.9
		250	1720	80.2	(b)	N/A	N/A	160.0	99.5	61.8	0.2	136.7	76.2	3.1
CVHG	480-565	050	565	56.6	N/A	N/A	N/A	N/A	N/A	N/A	N/A	78.1	41.5	N/A
		050/080	565	(a)	(a)	N/A	N/A	N/A	N/A	N/A	N/A	83.6	41.5	N/A
		080	565	(a)	(a)	N/A	N/A	N/A	N/A	N/A	N/A	88.2	54.6	N/A
	670-780	080	780	(a)	(a)	N/A	N/A	N/A	N/A	N/A	N/A	88.2	54.6	N/A
		080/142	780	(a)	(a)	N/A	N/A	N/A	N/A	51.8	N/A	112.0	54.62	N/A
		142	780	(a)	(a)	N/A	N/A	N/A	N/A	N/A	N/A	111.9	59.0	N/A
	920-1067	080/142	920	(a)	(a)	N/A	N/A	N/A	N/A	51.8	N/A	112.8	54.62	N/A
		142	920	(a)	(a)	N/A	N/A	N/A	N/A	N/A	N/A	111.9	59.0	N/A
		210	920	(a)	(a)	N/A	N/A	N/A	N/A	N/A	N/A	124.2	67.7	N/A
	1100	080/142	1100	(a)	(a)	N/A	N/A	N/A	N/A	51.8	N/A	112.8	54.62	N/A
		142	1100	(a)	(a)	N/A	N/A	N/A	N/A	51.8	1.8	113.9	59.0	N/A
		210	1100	(a)	(a)	N/A	N/A	N/A	N/A	61.5	(b)	124.2	67.7	N/A

Note: All dimensions are in inches (± 0.5 inch).

(a) See Table 5, p. 12.

(b) Does not extend beyond the main unit control panel.

Figure 1. For Table 1, p. 6, Table 2, p. 6, and Table 3, p. 7: Assembly for CVHE, CVHF, and CVHG (CVHF-080 shown)

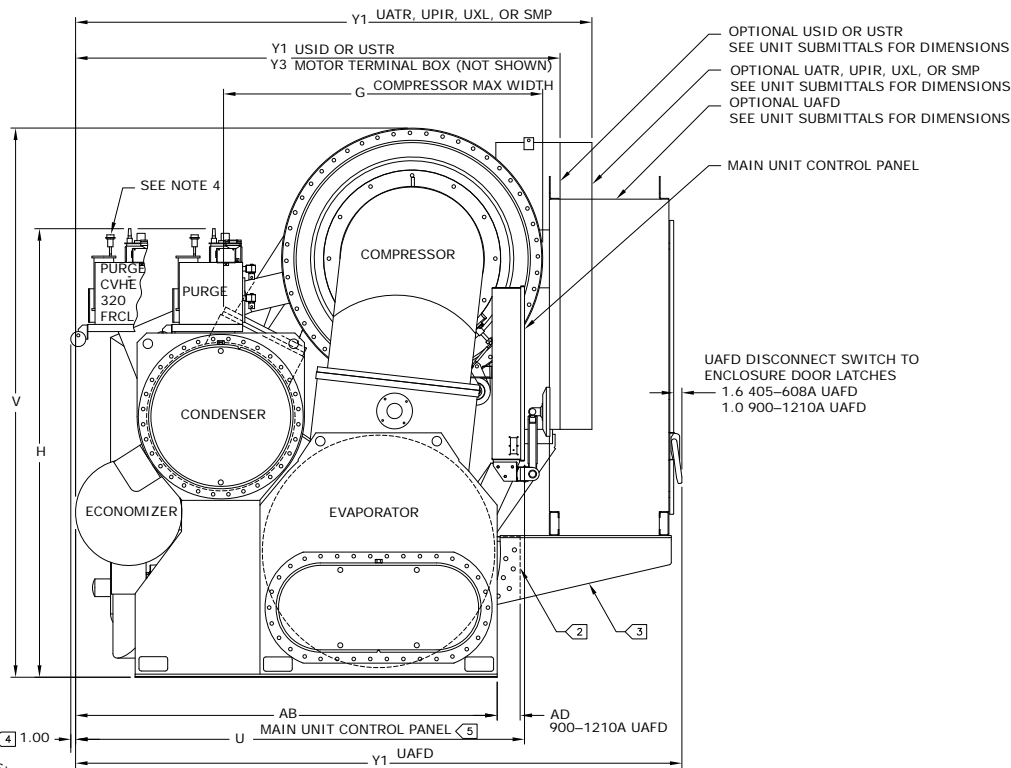

NOTES:

1. ALL DIMENSIONS ARE IN INCHES (± 0.5 INCH).
2. BRACKETS AND SUPPORTS ARE WELDED TO EVAPORATOR ON 405-808A UAFD.
3. BRACKETS ARE WELDED TO EVAPORATOR ON 900-1210A UAFD. SUPPORTS CAN BE UNBOLTED FROM BRACKETS.
4. APPLIES ONLY TO CVHE 190-320 NTON ON 032 SHELLS WITH FREE-COOLING OPTION.
5. ADD 1.5" FOR DISTANCE TO TRACER ADAPTVIEW DISPLAY MOUNTING ARM IN STOWED POSITION.

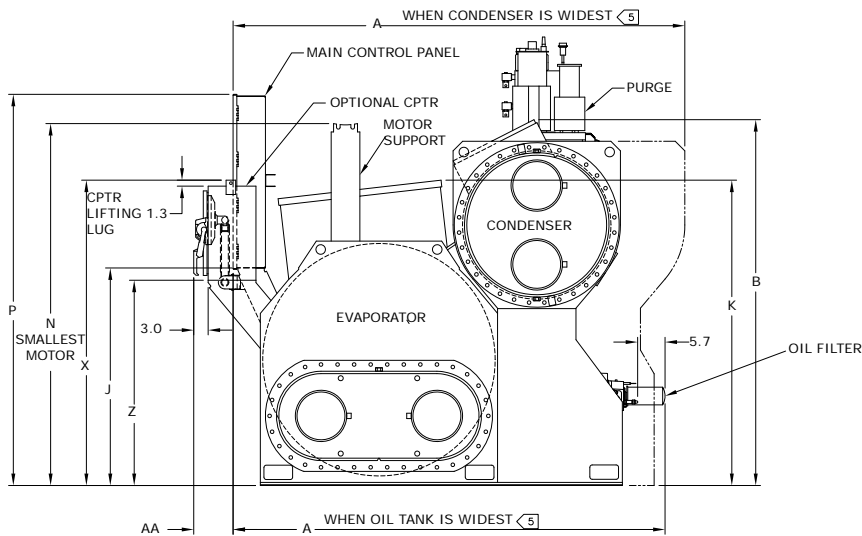

CVHF-080 UNIT SHOWN (COOLING ONLY) WITH COMPRESSOR AND ECONOMIZER REMOVED

Dimensions and Weights

Figure 2. For Table 1, p. 6, Table 2, p. 6, and Table 3, p. 7: Assembly for CVHE, CVHF, and CVHG (CVHF-080 shown)

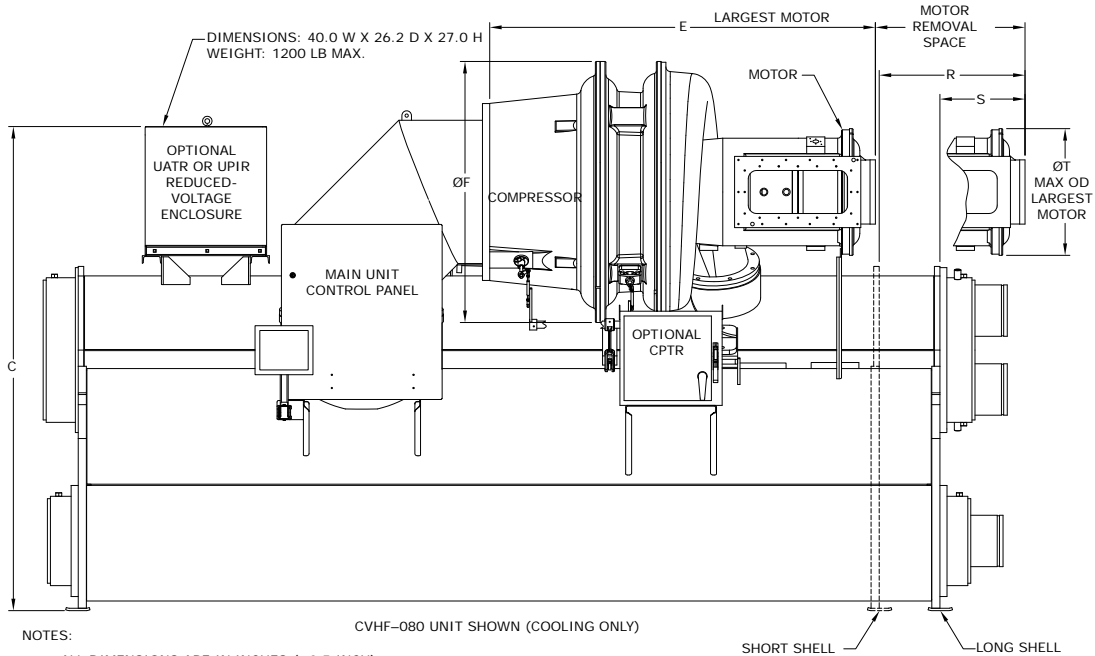

- NOTES:
- 1. ALL DIMENSIONS ARE IN INCHES (± 0.5 INCH).
 - 2. BRACKETS AND SUPPORTS ARE WELDED TO EVAPORATOR ON 405-808A UAFD.
 - 3. BRACKETS ARE WELDED TO EVAPORATOR ON 900-1210A UAFD. SUPPORTS CAN BE UNBOLTED FROM BRACKETS.
 - 4. APPLIES ONLY TO CVHE 190-320 NTON ON O32 SHELLS WITH FREE-COOLING OPTION.
 - 5. ADD 1.5" FOR DISTANCE TO TRACER ADAPTVIEW DISPLAY MOUNTING ARM IN STOWED POSITION.

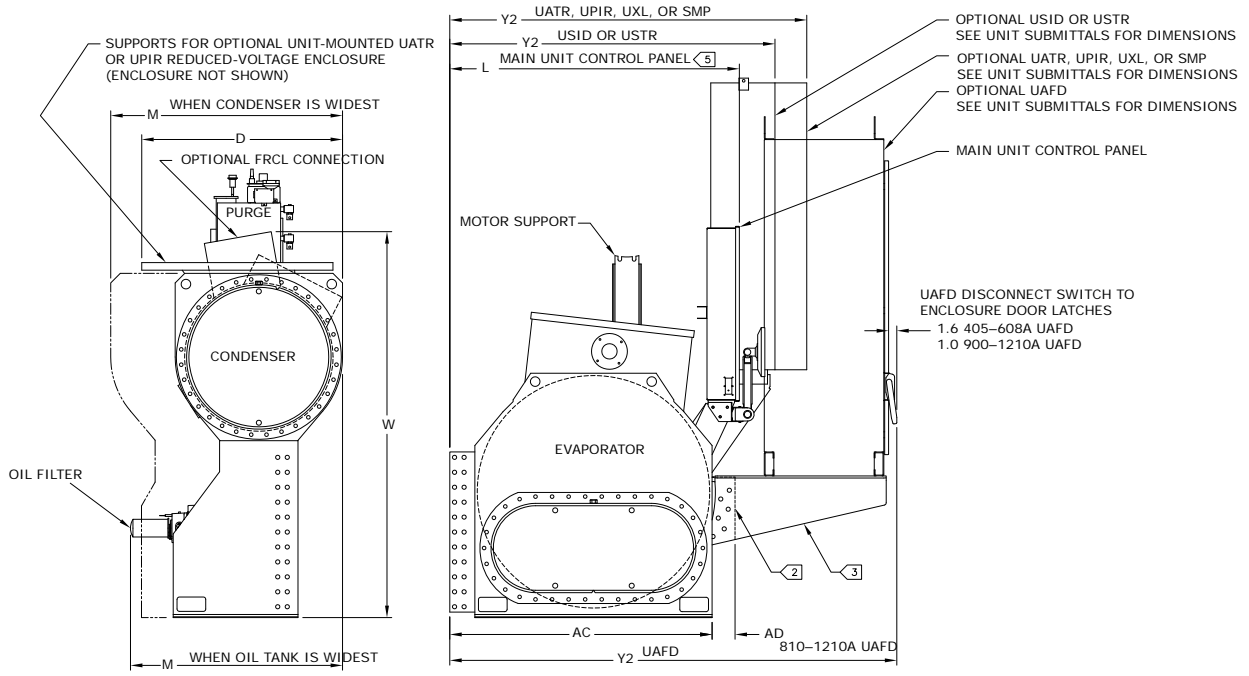

CVHF-080 UNIT SHOWN WITH COMPRESSOR AND ECONOMIZER REMOVED AND WITH OPTIONAL FRCL CONNECTION AND SEPARATED SHELLS

Table 4. Motor terminal boxes for CVHE, CVHF, and CVHG

Shell Size	Comp Size	Motor Size	Low Voltage		Medium Voltage		
			Std	INDP	Std	INDP	
			Y3		Y3		
032	320	360	(a)	N/A	N/A	N/A	
		400	(a)	N/A	N/A	N/A	
		440E	N/A	N/A	78.1	N/A	
050	320	360	(a)	N/A	N/A	N/A	
		400	(a)	N/A	N/A	N/A	
	450	400	(a)	N/A	N/A	N/A	
		440E	(a)	N/A	87.9	N/A	
	500	400	(a)	N/A	N/A	N/A	
		440E	(a)	N/A	87.7	N/A	
565	400	400	(a)	N/A	N/A	N/A	
		440E	(a)	N/A	88.5	N/A	
		440E	(a)	N/A	88.5	N/A	
080	480, 500	400	(a)	(a)	N/A	N/A	
		440E	(a)	(a)	(a)	(a)	
	565	400	400	(a)	N/A	N/A	N/A
			440E	(a)	N/A	100.8	N/A
			5000	(a)	N/A	102.3	N/A
	780	440E	440E	(a)	N/A	106.9	N/A
			5000	(a)	N/A	108.4	N/A
			5800	100.2	N/A	110.2	N/A
	870, 910	440E	440E	(a)	N/A	105.9	106.1
			5000	(a)	N/A	107.4	107.6
	050/080	480	400	(a)	N/A	N/A	N/A
			440E	(a)	N/A	97.2	N/A
500		400	(a)	N/A	N/A	N/A	
		440E	(a)	N/A	97.2	N/A	
565		400	400	(a)	N/A	N/A	N/A
			440E	(a)	N/A	100.9	N/A
080/142	780	440E	(a)	N/A	(a)	N/A	
		5000	(a)	N/A	(a)	N/A	
		5800	(a)	N/A	122.6	N/A	
	910	440E	(a)	(a)	(a)	(a)	
		5000	(a)	(a)	(a)	121.08	
	920, 1100	440E	(a)	N/A	(a)	N/A	
		5000	(a)	N/A	(a)	N/A	
		5800	(a)	N/A	123.4	N/A	
	870, 1300	440E	440E	(a)	(a)	(a)	(a)
			5000	(a)	(a)	(a)	(a)
			5800	(a)	(a)	123.4	123.7
	142	780, 910, 920	440E	(a)	(a)	(a)	(a)
5000			(a)	(a)	118.5	118.8	
5800			(a)	(a)	120.3	120.6	
870, 1100, 1300		440E	(a)	(a)	(a)	(a)	
		5000	(a)	(a)	120.5	120.8	
		5800	(a)	(a)	122.3	122.6	
210	920, 1100	440E	(a)	N/A	(a)	N/A	
		5000	(a)	N/A	(a)	N/A	
		5800	(a)	N/A	127.8	N/A	
	1300	440E	(a)	(a)	(a)	(a)	
		5000	(a)	(a)	(a)	(a)	
		5800	(a)	(a)	127.8	128.1	
	1720	5000	5000	(a)	(a)	(a)	(a)
			5800	(a)	(a)	127.8	128.1
			5800L	(a)	(a)	127.8	128.1

Note: All dimensions are in inches (± 0.5 inch).



Dimensions and Weights

Table 4. Motor terminal boxes for CVHE, CVHF, and CVHG (continued)

Shell Size	Comp Size	Motor Size	Low Voltage		Medium Voltage	
			Std	INDP	Std	INDP
			Y3		Y3	
250	1300	440E	(a)	(a)	(a)	(a)
		5000	(a)	(a)	(a)	(a)
		5800	(a)	(a)	(a)	(a)
	1720	5000	(a)	(a)	(a)	(a)
		5800	(a)	(a)	(a)	(a)
		5800L	(a)	(a)	(a)	(a)

Note: All dimensions are in inches (± 0.5 inch).

(a) Does not extend beyond the main unit control panel.

Table 5. Unit mounted starters for CVHE, CVHF, and CVHG

Shell Size	Comp Size	Motor Size	UATR UPIR		UATR UPIR		
			USID USTR	UXL SMP	USID USTR	UXL SMP	
			Y1		Y2		
080	480	400	103.3	N/A	69.7	N/A	
		440E	(a)	100.7	(a)	67.1	
	500	400	103.3	N/A	69.7	N/A	
		440E	(a)	100.7	(a)	67.1	
	565	400	103.7	N/A	70.1	N/A	
		440E	(a)	102.0	(a)	68.4	
	780	5000	96.8	103.5	63.2	69.9	
		440E	101.3	108.0	67.8	74.4	
		5000	102.8	108.7	69.3	75.1	
	870, 910	5800	104.6	111.3	71.0	77.7	
		440E	101.3	108.0	67.8	74.4	
		5000	102.8	109.5	69.3	75.9	
	050/080	480	400	92.4	N/A	51.59	N/A
			440E	94.9	101.6	54.09	60.85
		500	400	92.4	N/A	51.59	N/A
440E			94.9	101.6	54.09	60.85	
565		440E	96.2	103.0	54.09	60.85	
		5000	97.7	104.3	55.59	62.19	
080/142	780, 910	440E	(a)	121.2	(a)	63.89	
		5000	(a)	122.9	(a)	65.54	
	780	5800	(a)	124.5	(a)	67.19	
		440E	(a)	122.2	(a)	63.96	
	870, 920, 1100, 1300	5000	(a)	123.7	(a)	65.46	
		5800	(a)	125.5	(a)	67.26	
		440E	(a)	119.1	(a)	66.2	
142	780, 910, 920	5000	(a)	120.6	(a)	67.7	
		5800	(a)	122.4	(a)	69.5	
		440E	(a)	121.1	(a)	66.2	
	870, 1100, 1300	5000	(a)	122.6	(a)	67.7	
		5800	(a)	124.4	(a)	69.5	
		440E	(a)	126.6	(a)	70.1	
210	920, 1100, 1300	5000	(a)	128.1	(a)	71.6	
		5800	(a)	129.9	(a)	73.4	
		5000	127.4	134.1	70.9	77.6	
	1720	5800	(a)	129.9	(a)	73.4	
		5800L	(a)	129.9	(a)	73.4	

Note: All dimensions are in inches (± 0.5 inch).

(a) Does not extend beyond the main unit control panel.

Duplex Chillers: CDHF, CDHG
Table 6. For Figure 3, p. 14 and Figure 4, p. 15: Dimension data for CDHF and CDHG

Model	NTON	Shell	A	B	C	D	E	F	G	H	J	K	L	M	N
		Size													
CDHF	1500–2000 (2-Comp)	2100	107.4	-0.2	108.2	66.6	78.5	54.3	116.0	110.9	50.2	81.0	68.9	50.5	94.2
	2170 & 2550 (2-Comp)	2500	120.9	0.5	121.6	73.2	81.8	59.7	120.6	116.4	54.5	87.6	76.9	56.8	97.8
CDHG	1250–1750 (2-Comp)	2100	107.4	-0.2	108.2	66.6	95.0	54.3	116.0	110.9	50.2	81.3	68.9	50.5	94.2
	2250 (2-Comp)	2100	110.5	2.7	111.3	73.2	94.2	59.7	116.0	110.9	50.5	74.7	71.9	52.4	93.8
	2250 (2-Comp)	2500	120.9	0.5	121.6	73.2	94.2	59.7	120.6	116.4	54.5	79.7	76.9	56.8	94.6
CDHF	3000 (2-Comp)	250M	120.9	0.5	121.6	76.3	92.3	63.1	120.6	116.4	54.5	84.3	76.9	56.8	96.8
	3500 (2-Comp)	250X	120.9	0.5	121.6	76.3	92.3	63.1	120.6	116.4	54.5	84.3	76.9	56.8	96.8

Table 7. For Figure 3, p. 14 and Figure 4, p. 15: Dimension data for CDHF and CDHG

Model	NTON	Shell Size	AFD													
			900–1210A											UAFD Low Mount Control Panel		
			P	R	S	T	U	V	W	X	Z	AA	BB	CC	DD	EE
CDHF	1500–2000 (2-Comp)	2100	86.9	51.3	45.0	28.5	124.7	132.8	152.4	24.3	135.5	118.2	10.6	119.0	9.2	79.7
	2170 & 2550 (2-Comp)	2500	90.9	57.5	46.0	36.8	137.2	139.3	160.0	20.2	147.2	130.9	10.5	131.6	135.	86.9
CDHG	1250–1750 (2-Comp)	2100	86.9	51.3	45.0	32.4	124.7	132.8	N/A	N/A	N/A	N/A	N/A	N/A	N/A	N/A
	2250 (2-Comp)	2100	86.9	53.2	46.0	36.8	127.7	135.4	N/A	N/A	N/A	N/A	N/A	N/A	N/A	N/A
CDHG	2250 (2-Comp)	2500	90.6	57.5	46.0	36.8	137.2	139.3	N/A	N/A	N/A	N/A	N/A	N/A	N/A	N/A
	3000 (2-Comp)	250M	90.9	57.5	37.0	33.3	137.2	141.3	160.0	20.2	147.2	130.9	10.5	131.6	13.5	86.9
CDHF	3500 (2-Comp)	250X	90.9	57.5	37.0	33.3	137.2	141.3	160.0	20.2	147.2	130.9	10.5	131.6	13.5	86.9

Table 8. Motor terminal boxes and unit mounted starters for CDHF and CDHG

Shell Size	Compressor Size	Motor Size	Y1 USTR USID	Y2 UATR UPIR UXL	Y3 LV Motor Terminal Box	Y3 MV Motor Terminal Box
2100	091	440E	9.7	11.4	-10.2	-0.2
		5000	9.7	12.9	-8.7	1.3
	078	440E	9.7	11.4	-10.2	-0.2
		5000	9.7	12.9	-8.7	1.3
	092, 1100	440E	6.8	11.8	-13.1	-3.1
		5000	6.8	11.8	-11.6	-1.6
2500	130	5800	6.8	11.8	-9.8	0.2
		440E	3.6	0.5	-21.1	-11.1
		5000	3.6	2.0	-19.6	-9.6
	092, 110	5800	3.6	3.8	-17.8	-7.8
		440E	3.6	5.5	-21.1	-11.1
		5000	3.6	7.0	-19.6	-9.6
250M	147	5800	3.6	8.8	-17.8	-7.8
		5000	3.6	1.9	-13.6	-13.6
		5800	3.6	3.7	-7.9	-7.9
250X	172	5800L	3.6	3.7	-7.9	-7.9
		5000	3.6	1.9	-13.6	-13.6
		5800	3.6	3.7	-7.9	-7.9
250X	172	5800L	3.6	3.7	-7.9	-7.9
		5000	3.6	1.9	-13.6	-13.6

Dimensions and Weights

Figure 3. For Table 6, p. 13 and Table 7, p. 13: Assembly for CDHF and CDHG (CDHF shown)

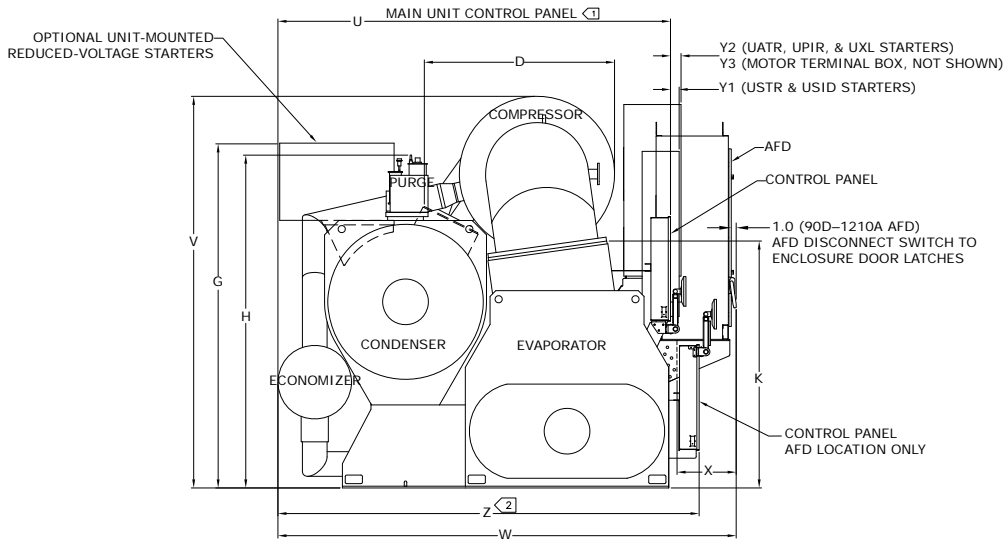

NOTES:

- $\langle 1 \rangle$ ADD 1.5" FOR DISTANCE TO TRACER ADAPTIVIEW DISPLAY MOUNTING ARM IN STOWED POSITION.
- $\langle 2 \rangle$ ADD 2.2" FOR DISTANCE TO TRACER ADAPTIVIEW DISPLAY MOUNTING ARM IN STOWED POSITION (AFD UNITS).
- $\langle 3 \rangle$ BRACKETS ARE WELDED TO EVAPORATOR ON 900-1210A AFD. SUPPORTS CAN BE UNBOLTED FROM BRACKETS.

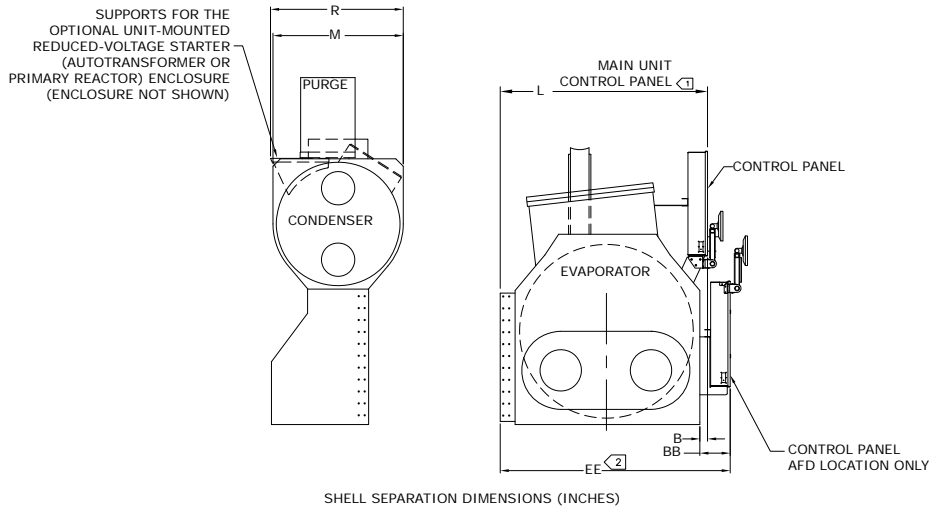
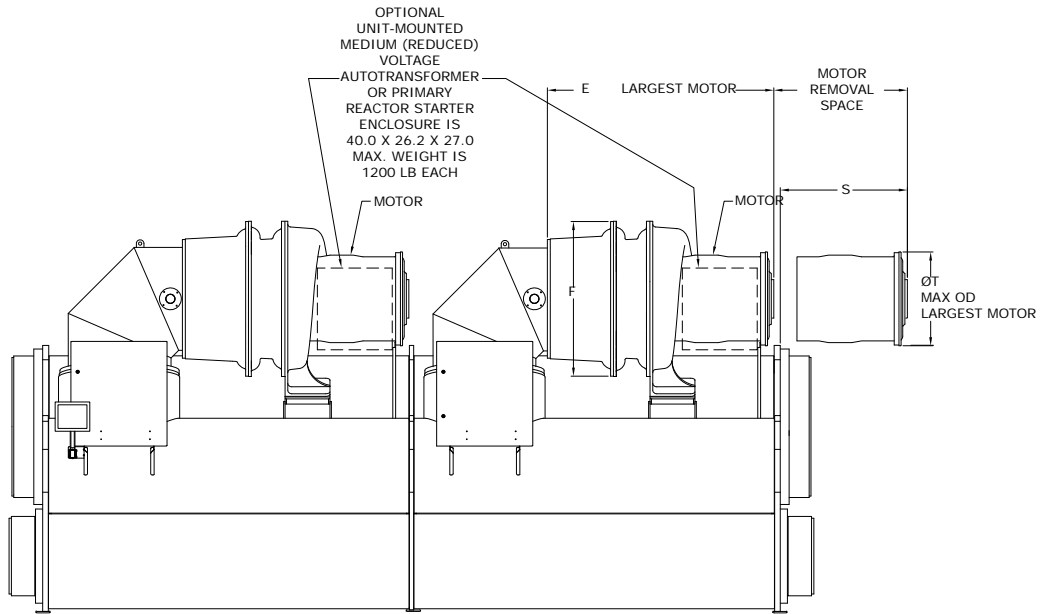

Figure 4. For Table 6, p. 13 and Table 7, p. 13: Assembly for CDHF and CDHG (CDHF shown)



CDHF UNIT SHOWN (COOLING ONLY)
CHILLER DIMENSIONS (INCHES)

NOTES:

- ① ADD 1.5" FOR DISTANCE TO TRACER ADAPTIVIEW DISPLAY MOUNTING ARM IN STOWED POSITION.
- ② ADD 2.2" FOR DISTANCE TO TRACER ADAPTIVIEW DISPLAY MOUNTING ARM IN STOWED POSITION (AFD UNITS)
- ③ BRACKETS ARE WELDED TO EVAPORATOR ON 900-1210A AFD. SUPPORTS CAN BE UNBOLTED FROM BRACKETS.

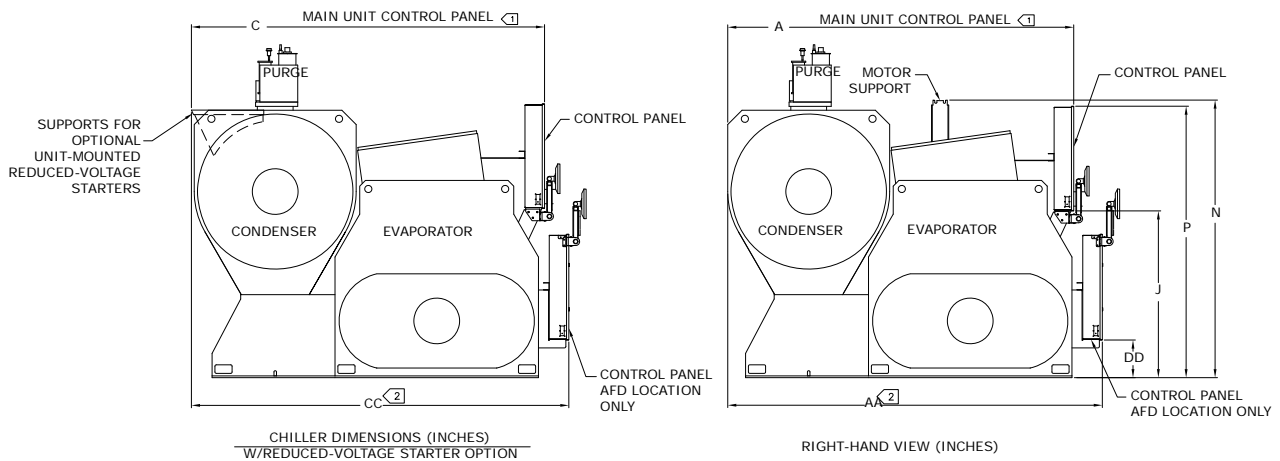



Dimensions and Weights

Weights

Single Compressor and Duplex Chillers: CVHE, CVHF, CVHG, CDHF, CDHG

Table 9. Compressor and motor weights^{(a),(b)}

Model	NTON	CPKW ^(c)	Volts	Hz	Motor Weight		Compressor & Motor Weight	
					lb	kg	lb	kg
CVHE	190–270	242	6600	50	2558	1160	7294	3308
	230–320	287	4160	60	2530	1147	7266	3295
	300–420	379	6600	50	2767	1255	8185	3712
	360–500	453	6600	60	3385	1535	8803	3992
CVHF	350–485	453	6600	60	3385	1535	8013	3634
	350–570	588	480	60	2803	1271	7431	3370
	620–870	957	2300	60	3862	1751	9900	4490
	650–910	957	2300	60	3862	1751	9900	4490
	1060–1280	1228	4160	60	4559	2067	10597	4806
	1070–1300	1228	4160	60	4559	2067	10714	4859
	1470–1720	1340	2400	60	5196	2356	13932	6319
CVHG	480–565	489	6600	50	3794	1720	10000	4535
	670–780	621	6600	50	4685	2125	11311	5130
	920–1067	621	6600	50	4685	2125	12151	5511
CDHF	1500–2000	745	460	60	3460	1569	9498	4308
	2100–2500	1062	460	60	4296	1948	10334	4687
	3500	1340	2400	60	5196	2356	13911	6309
CDHG	1250–1750	621	6600	50	4685	2125	11311	5130
	2150	621	6600	50	4685	2125	12151	5511

(a) For Duplex™ chillers, weights shown are for individual components; multiply by two for total component weights (for Duplex chillers only).

(b) All weights are nominal and $\pm 10\%$.

(c) Heaviest motor used; does not include the weight of the suction elbow.

Table 10. Component weights^{(a),(b)}

Model	Evaporator Shell Size	Control Panel		Purge		Oil Tank		Suction Elbow ^(c)		Economizer without Free Cooling		Economizer with Free Cooling	
		lb	kg	lb	kg	lb	kg	lb	kg	lb	kg	lb	kg
CVHE	032	119	54	140	64	350	159	279	127	404	183	564	256
CVHE/CVHG	050	119	54	140	64	350	159	280	127	635	288	885	401
	080	119	54	140	64	350	159	519	235	976	443	1296	588
CVHF	050	119	54	140	64	350	159	280	127	420	191	670	304
	080	119	54	140	64	350	159	519	135	735	333	1055	479
CVHG	142/210/250	119	54	140	64	350	159	722	327	878	398	1348	611
	142/210	119	54	140	64	350	159	722	327	1433	650	1903	863
CDHF	210/250D/250M/250X	119	54	140	64	350	159	683	310	878	398	1348	611
CDHG	210/250	119	54	140	64	350	159	1350	612	1433	650	1903	863

(a) For Duplex chillers, weights shown are for individual components; multiply by two for total component weights (for Duplex chillers only).

(b) All weights are nominal and $\pm 10\%$.

(c) Suction elbow weights include flanges and assume largest compressor available for that size.

Table 11. Evaporator and condenser bundle weights^(a)

Model	Shell Size	Bundle Size ^(b)	Evaporator				Condenser			
			Shell ^(c)		Water Box ^(d)		Shell ^(e)		Water Box ^(d)	
			lb	kg	lb	kg	lb	kg	lb	kg
CVHE	032S	320	2778	1260	653	296	2458	1115	644	292
	032L	320	3483	1579	653	296	3006	1363	644	292
CVHE/CVHF/CVHG	050S	700	4897	2221	1061	481	3526 ^(f)	1599	1328	602
	050L	700	5984	2714	1061	481	4436 ^(f)	2012	1328	602
	080S	1400	7884	3283	2490	1129	5280	2394	2565	1164
	080L	1400	9653	4066	2490	1129	6776	3073	2565	1164
	142M	1420	11036	5005	3701	1679	N/A	N/A	5330	2418
	142L	1420	11938	5414	3701	1679	10995	4987	5330	2418
	142E	1420	12921	5860	3701	1679	N/A	N/A	5330	2418
	210L	2100	14755	6692	6403	2904	14154	6420	7319	3320
	250	2500	20068	9102	8343	3784	17200	7801	9144	4148
	CDHF/CDHG	210D	2100	22437	10177	8382 ^(g)	3802 ^(g)	22635	10267	8928 ^(g)
250D		2500	24610	11162	10954 ^(g)	4969 ^(g)	25853	11726	11442 ^(g)	5190 ^(g)
250M		2500	28679	13008	10954 ^(g)	4969 ^(g)	29817	13524	11442 ^(g)	5190 ^(g)
250X		2500	31902	14470	10954 ^(g)	4969 ^(g)	33486	15188	11442 ^(g)	5190 ^(g)

- (a) All weights are nominal and $\pm 10\%$.
 (b) Bundle weights are for the maximum bundle size for chiller family with TECU.035 tubes.
 (c) Evaporator shell weight includes: Evaporator + Control Panel + Legs; water box weight is NOT included.
 (d) Based on two-pass marine, 300 lb (136 kg); includes supply and return.
 (e) Condenser shell weight includes: Condenser + Oil Tank + Purge + Legs; water box weight is NOT included.
 (f) Condenser bundle is a 500.
 (g) Based on 1-pass marine, 300 lb (136 kg); includes supply and return.

Table 12. Unit-mounted starters/Adaptive Frequency Drives^(a)

Low Voltage (less than 600 volts)	lb	kg
Wye Delta	557	252
Solid State	557	252

Adaptive Frequency Drive (less than 600 volts)	lb	kg
405 amp	1680	762
608 amp	1680	762
900 amp	3000	1360
1210 amp	3000	1360

Medium Voltage (2300–6600 volts)	lb	kg
Across the line	557	252
Primary Reactor	1586	719
Autotransformer	1639	743

- (a) All weights are nominal and $\pm 10\%$.



Compressor/Motor Disassembly

Remove Nitrogen Charge

Important: Remove the nitrogen charge from the chiller vessel before starting any disassembly procedures.

Introduction

The disassembly and reassembly procedures described in this manual should be performed only on chillers that have been ordered with this shell option. The process is to be initiated by experienced service technicians. Contact your local Trane Service office for assistance if required.

This section discusses a typical disassembly process. Proper lifting techniques vary based on mechanical room layout.

- It is the responsibility of the person(s) performing the work to be properly trained in the safe practice of rigging, lifting, securing, and fastening the components involved.
- It is the responsibility of the person(s) providing and using the rigging and lifting devices to inspect these devices to ensure they are free from defect and are rated to meet or exceed the published weights.
- Always use rigging and lifting devices in accordance with the applicable instructions for such devices.

Note: Additional gaskets and O-rings are shipped with the chiller when compressor doweling and/or separable shells are selected.

⚠ WARNING

Heavy Objects!

Each of the cables (chains or slings) used to lift the unit must be capable of supporting the entire weight of the component. Lifting cables (chains or slings) may not be of the same length. Adjust as necessary for even component lift. Other lifting arrangements may cause equipment or property-only damage. Failure to properly lift component could result in death or serious injury.

Wiring Disassembly

Before separating shells, remove the purge, the compressor, and the various unit mounted sensors (frame LLIDs) as indicated. If possible, the best method is to remove the sensor and carefully coil the wire after labeling the device and its location to aid in reinstallation. All sensors connect to the buss wiring with a universal plug. This allows easy disconnection and reconnection of the sensors.

Purge Unit Removal

⚠ WARNING

Refrigerant under Positive Pressure!

System contains oil and refrigerant and may be under positive pressure. Recover refrigerant to relieve pressure before opening the system. See unit nameplate for refrigerant type. Do not use non-approved refrigerants, refrigerant substitutes, or refrigerant additives. Failure to recover refrigerant to relieve pressure or the use of non-approved refrigerants, refrigerant substitutes, or refrigerant additives could result in an explosion which could result in death or serious injury or equipment damage.

⚠ WARNING

Hazardous Voltage w/Capacitors!

Disconnect all electric power, including remote disconnects and discharge all motor start/run capacitors before servicing. Follow proper lockout/tagout procedures to ensure the power cannot be inadvertently energized. Verify with an appropriate voltmeter that all capacitors have discharged. Failure to disconnect power and discharge capacitors before servicing could result in death or serious injury.

For additional information regarding the safe discharge of capacitors, see PROD-SVB06A-EN

To remove the purge assembly from the top of the condenser:

1. Isolate the purge unit from the condenser shell by closing the vapor and liquid line valves.
2. Disconnect and mark all piping and wiring attached to the purge unit. Sand all paint off at points and use a tubing cutter where cuts are to be made. See [Figure 5, p. 19](#) and [Figure 6, p. 19](#).
3. Remove the fasteners connecting the purge unit base to its mounting bracket.
4. Lift the purge unit clear of the chiller and store in a clean, dry area.

Reassemble the purge unit in reverse order when the process is complete.

Figure 5. Purge unit



Figure 6. Purge unit detail

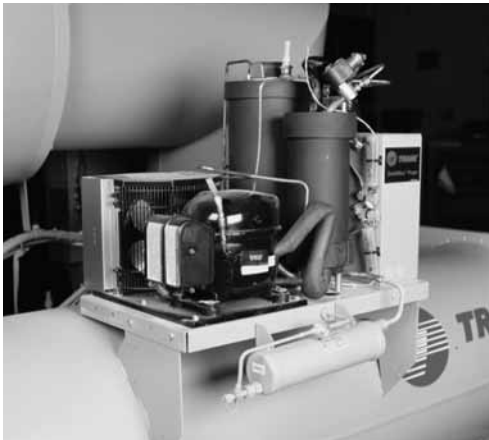

Compressor Motor Assembly Removal

NOTICE:

Doweling Must Be Completed Prior to Disassembly!

The compressor motor assembly must not be removed from the chiller unless special doweling has been installed at the factory. Doweling must be installed to prevent the interstage casings from shifting. If the compressor/motor assembly is lifted without doweling installed, the internal alignment may shift. It would then be necessary to disassemble and then reassemble the compressor making sure that all internal clearances and specifications are proper. If the internal components shift and the chiller is started, serious compressor damage could result. If doweling is not factory installed, and it is necessary to install doweling, contact the local Trane Service Company. The compressor discharge flange and mounting foot are also doweled at the factory to provide proper alignment during reassembly.

Figure 7, p. 19 through Figure 9, p. 19 show factory-installed compressor doweling. If components are not factory doweled, doweling must be installed before proceeding. Contact the local Trane Service Company.

Figure 7. Compressor dowelings on casings

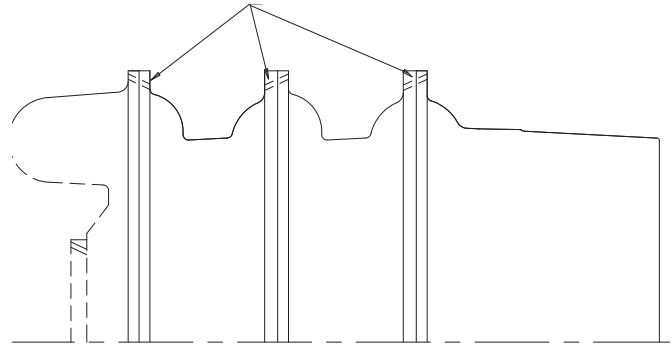

Figure 8. Compressor doweling on evaporator foot (these are standard on all CenTraVac chillers)

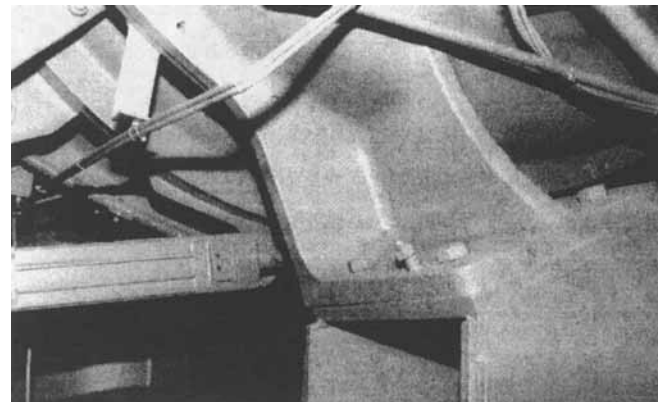
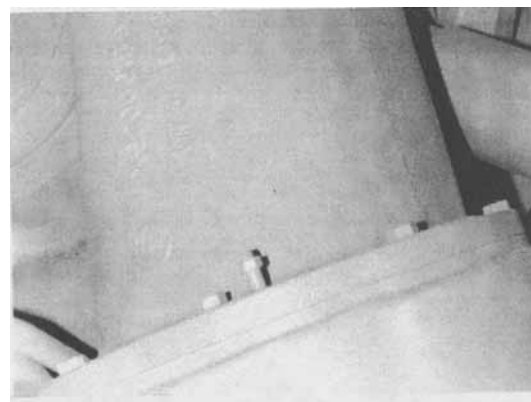

Figure 9. Compressor doweling on condenser discharge flange (these are standard on all CenTraVac chillers)



1. Disconnect the inlet vane linkage.
 - a. Disconnect the rod end bearings connecting the inlet vane operator levers to the guide vane links as in Figure 10, p. 20 and Figure 11, p. 20. Leave the

Compressor/Motor Disassembly

rod end bearing connecting the guide vane links to the main drive levers attached.

Note: Do not rotate the rod end bearings on the shaft as this will alter the inlet guide vane operations and compressor performance.

- b. Remove the cotter pin securing the vane operator stud to the vane drive and slide the stud out of the main drive. See [Figure 12, p. 20](#).
- c. Remove the hex head bolts securing the vane drive support assemblies to the compressor castings and remove the main drive and inlet vane levers from the compressor as a unit. See [Figure 12, p. 20](#).
- d. Remove the hex head bolts securing the vane drive support assemblies to the compressor castings and remove the main drive and inlet vane levers from the compressor as a unit. See [Figure 12, p. 20](#).

Figure 10. Vane actuator level on suction cover



Figure 11. Vane actuator level on interstage



Figure 12. Vane actuator operator mechanism

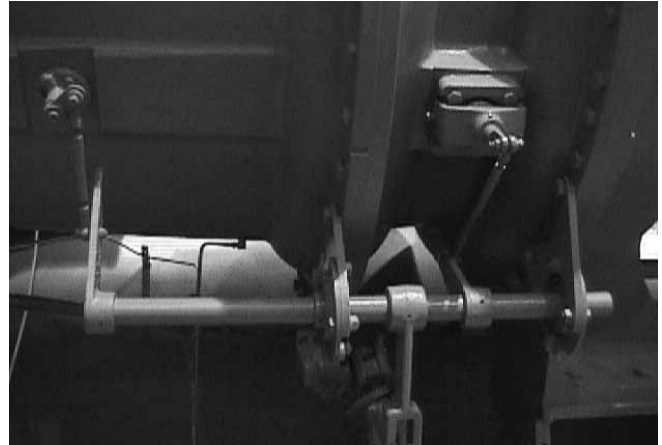

⚠ WARNING

Refrigerant under Positive Pressure!

System contains oil and refrigerant and may be under positive pressure. Recover refrigerant to relieve pressure before opening the system. See unit nameplate for refrigerant type. Do not use non-approved refrigerants, refrigerant substitutes, or refrigerant additives. Failure to recover refrigerant to relieve pressure or the use of non-approved refrigerants, refrigerant substitutes, or refrigerant additives could result in an explosion which could result in death or serious injury or equipment damage.

2. Disconnect all external vent lines, motor cooling supply and drain lines, and oil supply and drain lines which are connected to the compressor and compressor motor. Sand all paint off the points where cuts are to be made. Use a tubing cutter to ensure that cuts are smooth and square. [Figure 13, p. 21](#) and [Figure 14, p. 21](#) illustrate these lines. Couplings will be used to reconnect the lines when reassembling the chiller. Cap open lines to prevent entry of foreign material.

Figure 13. Lubrication system supply, drain, and vent lines

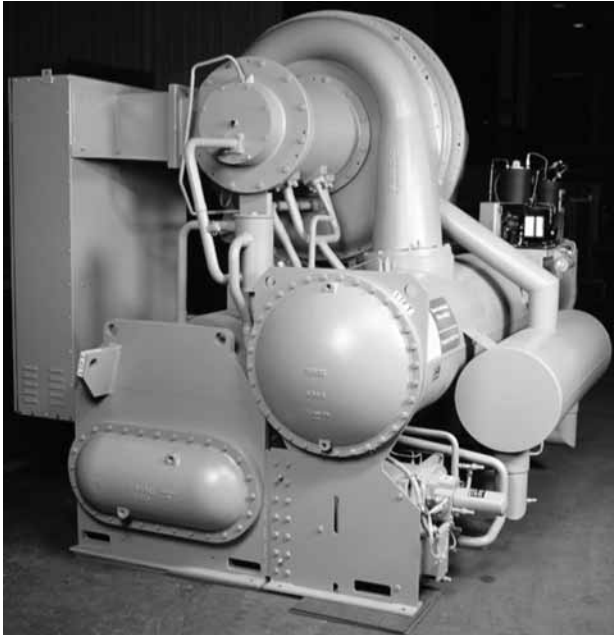

Figure 14. Lubrication system motor cooling lines



3. Remove the control panel if necessary. Also, disconnect and remove the unit mounted starter, if so equipped. See [“Control Panel Removal,” p. 24](#) for instructions.
4. Remove the economizer vent pipe flange bolts at the compressor connection. See [“Economizer Removal,” p. 23](#) for instructions.

⚠ WARNING

Heavy Objects!

Each of the cables (chains or slings) used to lift the unit must be capable of supporting the entire weight of the component. Lifting cables (chains or slings) may not be of the same length. Adjust as necessary for even component lift. Other lifting arrangements may cause equipment or property-only damage. Failure to properly lift component could result in death or serious injury.

5. Only Trane Service Agencies have access to the certified lifting plates to allow safe compressor/motor assembly removal. Before removing the compressor/motor assembly, consult with a rigging specialist. Employ rigging specialist procedures when removing the compressor motor/assembly.

⚠ WARNING

Improper Use of Elbow Lifting Tab!

Do not lift chiller using elbow lifting tab. Elbow lifting tab and approved clevis are used **ONLY** when removing elbow from chiller. Using the elbow lifting tab to lift chiller could result in chiller dropping which could result in death, serious injury, or equipment damage.

6. Remove the suction elbow.

There are two styles of suction elbows, a 90° elbow and a three-piece elbow, that can be found in the disassembly process.

 - a. Use a sling to support the 90° elbow style suction elbow. Apply slight lifting pressure.
 - b. Three-piece suction elbows have a lifting tab. You will need a lifting clevis to remove the elbow. A Crosby screw pin shackle, model S-209, stock number 1018482 with a 5/8-in. pin is acceptable as shown in [Figure 15](#).

Compressor/Motor Disassembly

Figure 15. Lifting clevis on the suction elbow lifting tab (three-piece elbow style)



- c. Remove the bolts from the control mounting bracket on the back of the control panel.
 - d. Remove the suction elbow bolts at the compressor and evaporator connections.
 - e. Lift the suction elbow from the chiller being careful to avoid damage to flange surfaces.
 - f. Install protective covers on the evaporator and compressor connections. Plastic secured with duct tape makes an adequate cover if no heavy objects are set on the openings.
7. Support the compressor/motor assembly as indicated by the rigging specialist (see [Step 5, p. 21](#)). Do not lift the assembly; instead support the assembly to prevent it from slipping as the compressor foot and discharge connection flange bolts are removed.

NOTICE:

Handle with Care!

The cast iron foot of the compressor and the discharge flange of the volute can be broken easily if rough handling of the compressor/motor assembly is allowed. Take great care to prevent this breakage when removing the compressor/motor assembly and setting it down, or when moving it laterally on the floor (e.g., on rollers, etc). Take extra care to gently sit the compressor/motor assembly down and avoid letting it swing or drop into an obstruction while lifting or moving it. Failure to follow these instructions could cause equipment damage.

8. Remove the compressor/motor assembly. Remove the locating dowel pins from the compressor foot and discharge flange connections as shown in [Figure 8, p. 19](#) and [Figure 9, p. 19](#). To remove the dowel pin, first remove the nut on the dowel pin, place a bushing on the pin, and then reinstall the nut. As the nut is tightened, the dowel pin should pull out of its hole; at this point, remove the compressor/motor assembly.

Compressor Motor Mount Disassembly

If additional vertical clearance is required, the height of the compressor motor mount can be reduced. Use the following procedure:

1. Before cutting off the motor mount, first fabricate a 1/4-inch steel backing plate.
 - a. Cut the backing plate to shape and clamp it to the motor mount.
 - b. Drill four 1/4-inch holes through the motor mount and the backing plate as shown in [Figure 16](#). These holes with bolts or roll pins installed will be used to align the components during reassembly.
 - c. Remove the backing plate.
2. Using an oxyacetylene torch, cut the mount as shown in [Figure 16](#).

During reassembly, use the backing plate with bolts or roll pins to locate the pieces properly. After the pieces are located, Trane recommends welding the mount and backing plate in place.

Figure 16. Motor support detail

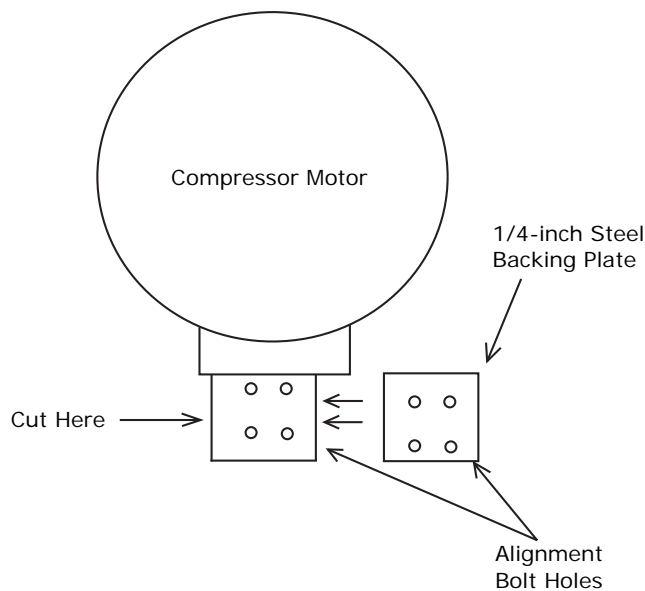

Economizer Removal

⚠ WARNING

Heavy Objects!

Each of the cables (chains or slings) used to lift the unit must be capable of supporting the entire weight of the component. Lifting cables (chains or slings) may not be of the same length. Adjust as necessary for even component lift. Other lifting arrangements may cause equipment or property-only damage. Failure to properly lift component could result in death or serious injury.

⚠ WARNING

Refrigerant under Positive Pressure!

System contains oil and refrigerant and may be under positive pressure. Recover refrigerant to relieve pressure before opening the system. See unit nameplate for refrigerant type. Do not use non-approved refrigerants, refrigerant substitutes, or refrigerant additives. Failure to recover refrigerant to relieve pressure or the use of non-approved refrigerants, refrigerant substitutes, or refrigerant additives could result in an explosion which could result in death or serious injury or equipment damage.

Use the following steps to remove the economizer if additional horizontal clearance is required.

1. Support the weight of the economizer with a movable floor jack. Do not lift the economizer; simply support it. Economizer weights are provided in [Table 10, p. 16](#); also see submittal. It is recommended that larger size economizers be lifted using overhead rigging.
2. If the unit has insulation, remove the insulation and loosen the bolts on the condenser liquid line flange. See [Figure 17](#). Do not remove the bolts at this time. Cut the motor cooling drain line(s) if present and cut entering and leaving 5/8 inch OD copper oil cooler lines. Refer to [Figure 13, p. 21](#).

Figure 17. Condenser liquid line flange

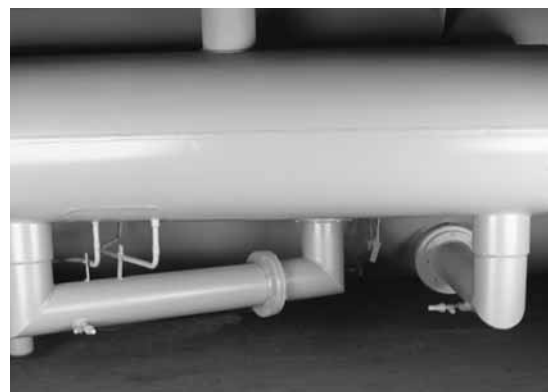

Compressor/Motor Disassembly

3. Loosen the bolts on the evaporator liquid line flange. This connection is near the bottom of the evaporator. See [Figure 17](#). Do not remove the bolts at this time.
4. Economizers are connected to the condenser shell via a bolted flange. See [Figure 22, p. 26](#). Remove the bolts at this flanged connection.
5. Loosen the economizer vent pipe bolts that secure the vent pipes to the compressor interstage castings (unless the compressor has already been removed to gain vertical clearance.)
6. Secure economizer with appropriate rigging.
7. Remove the bolts from the condenser and evaporator liquid line connection flanges. Adjust the floor jack as necessary to support the weight of the economizer.
8. Remove the economizer vent pipe flange bolts to loosen the economizer. When the bolts are free, back the economizer away from the chiller. The economizer may tend to rotate off the jack towards the chiller. Be prepared to offset the rotation.
9. Remove the economizer orifice plates and mark them so they are reinstalled in their original position. The orifice with the greatest number of holes is to be located between the economizer and the evaporator. The orifice with fewer holes is to be located between the condenser and economizer.
10. Move the economizer away from the chiller and set it on a pallet. Cover all openings to prevent the entry of foreign material into the economizer, condenser and compressor.
11. Use the reverse order to reassemble the economizer on the chiller. Be sure to install new gaskets at the appropriate joints.
12. Torque all bolts to specifications. Consult with your Trane service group for specific torques for your economizer design.

Tracer AdaptiView Display Arm Removal

⚠ WARNING

Hazardous Voltage w/Capacitors!

Disconnect all electric power, including remote disconnects and discharge all motor start/run capacitors before servicing. Follow proper lockout/tagout procedures to ensure the power cannot be inadvertently energized. Verify with an appropriate voltmeter that all capacitors have discharged. Failure to disconnect power and discharge capacitors before servicing could result in death or serious injury.

For additional information regarding the safe discharge of capacitors, see PROD-SVB06A-EN

Use the following steps to remove the Tracer AdaptiView™ display arm if additional clearance is required.

1. Cut tie wraps holding wires inside of control arm and remove wires from arm.
2. Remove 3-3/8-in. bolts from the angle bracket attached to the control panel mounting bracket.
3. Use the reverse order to re-attach the arm to the control panel mounting bracket.

Control Panel Removal

⚠ WARNING

Hazardous Voltage w/Capacitors!

Disconnect all electric power, including remote disconnects and discharge all motor start/run capacitors before servicing. Follow proper lockout/tagout procedures to ensure the power cannot be inadvertently energized. Verify with an appropriate voltmeter that all capacitors have discharged. Failure to disconnect power and discharge capacitors before servicing could result in death or serious injury.

For additional information regarding the safe discharge of capacitors, see PROD-SVB06A-EN

Use the following steps to remove the control panel if additional horizontal clearance is required.

1. Mark and disconnect incoming wiring to the control panel.
2. Remove the bolts from the bottom of the panel which secure the panel to the lower mounting bracket.
3. Loosen the bolts on the back of the panel which secure the panel to the top (suction elbow) mounting bracket. See [Figure 18](#).

Figure 18. Control panel mounting bracket



4. Two people will be needed to lift the panel clear of the chiller. Refer to [Table 10, p. 16](#) for control panel weight. Steady the panel as the top retaining bolts are removed. Then lift the panel clear. Store the panel in a clean dry area.

- Use the reverse order to reassemble the control panel.

Unit-mounted Starter Removal

Additional horizontal and vertical clearances may be obtained by removing the unit-mounted starter on chillers so equipped. See [Figure 19](#) (below) and [Figure 20](#), p. 25.

Figure 19. Unit mounted starter



Figure 20. Starter mounting bracket



The following procedure assumes the chiller is new and has never been installed and therefore there is no electrical power connected to the chiller. *If there is power to the unit, follow proper lockout/tagout procedures, and any other applicable safety regulations regarding electric power.*

⚠ WARNING

Hazardous Voltage w/Capacitors!

Disconnect all electric power, including remote disconnects and discharge all motor start/run capacitors before servicing. Follow proper lockout/tagout procedures to ensure the power cannot be inadvertently energized. Verify with an appropriate voltmeter that all capacitors have discharged. Failure to disconnect power and discharge capacitors before servicing could result in death or serious injury.

For additional information regarding the safe discharge of capacitors, see PROD-SVB06A-EN

- Mark and disconnect the power wiring at the compressor motor terminal lugs inside the starter panel.
- Mark and disconnect control wiring entering the starter panel.
- Remove the bolts securing the bottom of the starter to the brackets on the evaporator.
- To move the starter panel away from the chiller, it is recommended that a fork truck be used. Position the truck so that it is ready to take up the weight of the starter panel. The panel is top-heavy and must be adequately secured before moving. Refer to [Table 12](#), p. 17 for starter weights.

⚠ WARNING

Heavy Objects!

Always place, assemble, and suspend modules/subassemblies one at a time. Placing, assembling, and/or suspending more than one module/subassembly at a time could result in death, serious injury, or equipment damage.

- Loosen the bolts which hold the starter to the flange on the motor. Steady the starter panel as the retaining bolts are removed because the panel will tip forward. See [Figure 19](#), p. 25.
- Support the weight of the starter panel with the fork truck and carefully remove the starter panel from the chiller. Store the panel in a clean dry area free of any corrosive agents. When ready, reassemble the panel on the chiller in reverse order.

Condenser/Evaporator Disassembly

After the compressor assembly has been removed on separable shell units, the condenser and evaporator shells can be taken apart at flanged connections to reduce the horizontal clearance required for the chiller installation.

⚠ WARNING

Heavy Objects!

Each of the cables (chains or slings) used to lift the unit must be capable of supporting the entire weight of the component. Lifting cables (chains or slings) may not be of the same length. Adjust as necessary for even component lift. Other lifting arrangements may cause equipment or property-only damage. Failure to properly lift component could result in death or serious injury.

1. Ensure that condenser and evaporator shells are securely supported on level ground. If not, shim under the bases.
2. Support the condenser with rigging using the lifting holes on the tube sheets. See [Figure 21](#). Do not lift the shell, simply support it to avoid slipping as the bolts are removed from the connecting flange.

Figure 21. Separable shell unit (end view)

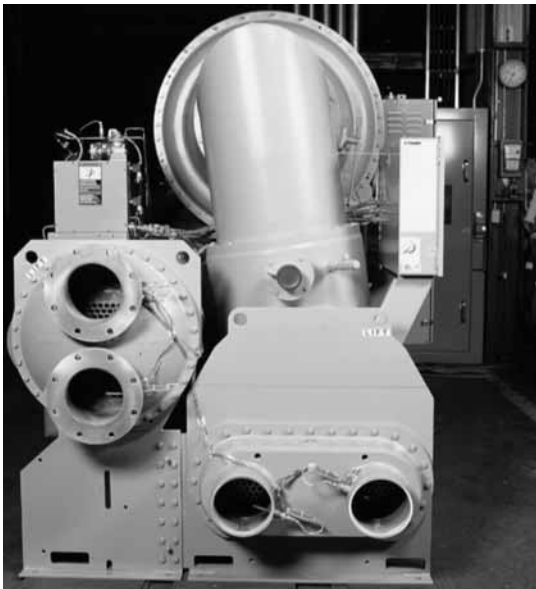

3. Remove the bolts from the flanges connecting the evaporator tube sheet and condenser shell support (see [Figure 22](#)). Then remove the bolts from the flanges connecting the shells.
Note: Some small shell combinations do not have flanged connections between shells.
4. Remove the two dowel pins located in the flange on each end of the shell tube sheet connections and lift the condenser clear of the evaporator.
5. Reassemble the evaporator and condenser shells in the reverse order.
6. Torque all bolts to specifications listed in [Table 13](#), p. 29.

Figure 22. Separable shell unit (flange connection)



Disassembly of Chillers with Options

Heat Recovery

Use the following steps when disassembling chillers with auxiliary or heat recovery condenser shells to reduce the vertical clearance required for the chiller installation.

⚠ WARNING

Heavy Objects!

Do not use cables (chains or slings) except as shown. Each of the cables (chains or slings) used to lift the unit must be capable of supporting the entire weight of the unit. Lifting cables (chains or slings) may not be of the same length. Adjust as necessary for even unit lift. Other lifting arrangements may cause equipment or property-only damage. Failure to properly lift unit could result in death or serious injury. See details below.

⚠ WARNING

Refrigerant under Positive Pressure!

System contains oil and refrigerant and may be under positive pressure. Recover refrigerant to relieve pressure before opening the system. See unit nameplate for refrigerant type. Do not use non-approved refrigerants, refrigerant substitutes, or refrigerant additives. Failure to recover refrigerant to relieve pressure or the use of non-approved refrigerants, refrigerant substitutes, or refrigerant additives could result in an explosion which could result in death or serious injury or equipment damage.

1. Support the auxiliary or heat recovery condenser with rigging using the lifting holes on the tube sheets. Do not lift the shell; simply support it to avoid slipping as the bolts are removed from the connecting flanges.
2. Remove the bolts from the flanges on the interconnecting piping and flanges connecting the auxiliary heat recovery condenser and condenser tube sheets.
3. Remove the bolts from the flanges on the interconnecting piping and the flanges connecting the shells.
4. Lift the condenser clear of the unit.
5. Reassemble the condenser in the reverse order. Install new gaskets at the appropriate joints.
6. Torque all bolts to torque specifications listed in [Table 13, p. 29](#).
7. Remove and coil up sensors.

Free Cooling

Use the following steps on free cooling units to reduce the vertical clearance required for chiller installation.

1. Support the piping and free cooling valve between the condenser and suction elbow with rigging similar to that used for removing the suction elbow. Do not lift the piping; simply support it to avoid slipping as the bolts are removed from the connecting flanges. (Typical rigging for lifting the suction elbow can be seen in [Figure 15, p. 22](#).)
2. Remove the bolts from the flanges.
3. Lift the piping clear of the unit.
4. Reassemble the piping in the reverse order. Install new gaskets at the appropriate joints.
5. Torque all bolts to torque specifications listed in [Table 13, p. 29](#).

Compressor/Motor Reassembly

It is important to remove used O-rings and gaskets and clean joints before reassembling the compressor with new O-rings and gaskets. All necessary replacement O-rings and gaskets are supplied by the factory when the compressor doweling or separable shell options are ordered.

Use the following procedure to reattach the compressor/motor assembly to the chiller.

1. Remove the protective covers on all compressor, condenser, and evaporator connections. Clean all mating surfaces using Loctite® "Chisel" cleaner or CRC® Industrial Gasket Remover. Completely remove old sealing compound from O-ring grooves. Use Loctite "N" primer for final surface preparation.
2. Refer to CTV-SB-66F (*General Service Bulletin: CenTraVac O-Ring and Flange Sealant*), or the most recent version, for proper installation of gaskets, O-Rings, and Loctite sealant. Install a new O-ring on the compressor discharge connection mating surfaces. Use Loctite 515 "Gasket Eliminator" to lubricate the O-ring and provide additional sealing. This is the only sealing compound recommended by Trane for use on O-ring joints. To use this sealing compound, apply a light bead (approximately 1/8-in. in diameter) to the O-ring groove, insert the O-ring and then apply a light bead to the O-ring. Also apply a 1/8-in. bead of sealing compound between the O-ring groove and the bolt hole circle. The parts can now be assembled.
3. Lift the compressor/motor assembly into place. Insert the bolts in the compressor foot and discharge flange connections. Before tightening any of these bolts, reinstall the dowel pins in the compressor foot and discharge flange.
4. Tighten the compressor foot and discharge flange bolts. See [Table 13, p. 29](#) for bolt torque specifications.
5. Install and tighten the motor mount bolts. See [Table 13, p. 29](#) for bolt torque specifications.
6. Remove the lifting equipment.
7. Set up dial indicators on the compressor end of the compressor/motor assembly. See [Figure 23](#). The dial indicators are used to monitor horizontal and vertical movement of the compressor/motor assembly when the suction elbow retaining bolts are tightened. Support the dial indicators from the condenser or from a floor stand.

Figure 23. Suction elbow flange bolts

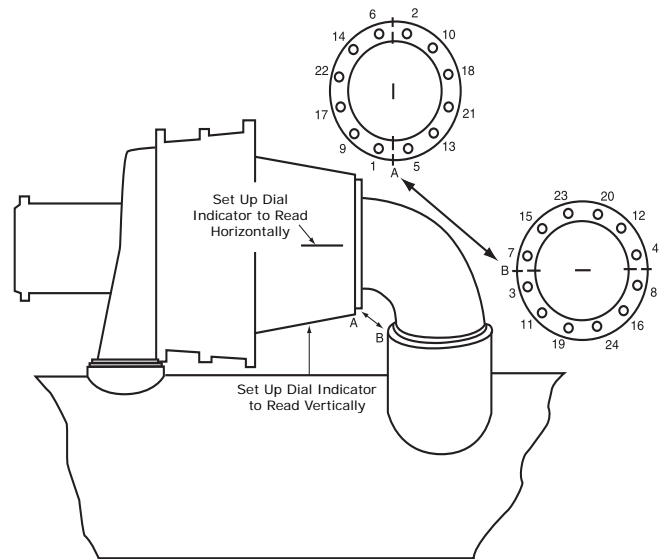

8. Clean the suction elbow flange surfaces and O-ring grooves per [Step 1](#). For the evaporator to suction elbow joint, use Loctite 515 per [Step 2](#). For the suction elbow to compressor joint, use 1/8-in. GORE-TEX® Joint Sealant placed approximately 1/8-in. in board of the O-ring groove. This is used in addition to the O-ring. As an option, Loctite 515 may be used in place of GORE-TEX. However, great care must be taken to prevent the sealant from entering the first stage IGV housing. Refer to CTV-SB-66F (*General Service Bulletin: CenTraVac O-Ring and Flange Sealant*), or the most recent version.
9. Lift the suction elbow into place using a sling or chain-fall hoist.
10. Install the suction elbow retaining bolts.
11. Tighten the retaining bolts only "hand tight". Tighten two retaining bolts, 180 degrees apart at the compressor connection. Then tighten two bolts, 180 degrees apart at the evaporator connection. Alternate between connections until all retaining bolts are tight. Monitor the dial indicators to ensure that there is no more than 0.010 inches of compressor movement. If there is more movement than this, loosen all of the bolts, "zero" the dial indicators and repeat the procedure. [Figure 23](#) illustrates the bolt tightening sequence.
12. Reconnect the economizer vent pipes. Be sure to clean the mating surfaces and use new gaskets on the connections. Tighten the flange bolts just enough so that the gasket material just begins to extrude from between the flanges.
13. Reinstall all other chiller components which were removed. Reconnect the inlet vane linkages.

14. Torque all bolts to specifications listed in [Table 13](#).

Table 13. Bolt torques

Non-Gasketed Joints Bolt Torques	
Bolt Size (in)	Torque (ft·lb)
1/2	70
5/8	150
3/4	250

All Other Metal Joints (O-Ring Joins) Shall Use the Following Torques

Bolt Size (in)	Torque (ft·lb)	
	Min.	Max.
1/4	5	7
5/16	11	15
3/8	22	27
1/2	55	75
5/8	120	165
3/4	200	280
1	400	550

All Joints with Flat Elastomeric Gaskets Shall Use the Following Bolt Torque

Bolt Size (in)	Torque (ft·lb)	
	Min.	Max.
5/16	8	12
3/8	12	18
1/2	33	50
5/8	70	90
3/4	105	155

15. Reconnect the previously cut compressor/motor oil supply and return lines and the motor cooling lines using the factory-supplied couplings.

Brazing

WARNING

Hazard of Explosion and Deadly Gases!

Never solder, braze or weld on refrigerant lines or any unit components that are above atmospheric pressure or where refrigerant may be present. Always remove refrigerant by following the guidelines established by the EPA Federal Clean Air Act or other state or local codes as appropriate. After refrigerant removal, use dry nitrogen to bring system back to atmospheric pressure before opening system for repairs. Mixtures of refrigerants and air under pressure may become combustible in the presence of an ignition source leading to an explosion. Excessive heat from soldering, brazing or welding with refrigerant vapors present can form highly toxic gases and extremely corrosive acids. Failure to follow all proper safe refrigerant handling practices could result in death or serious injury.

Except as noted in the following, braze with the following filler metals:

- Braze all copper-to-copper joints with A.W.S. BcuP-6 filler metal.
- Braze all copper-to-brass joints with A.W.S. BcuP-6 filler metal using white or black brazing flux.
- Braze all other joints with A.W.S. Bag-28 filler metal.

Bleed dry nitrogen through the lines while brazing to prevent the formation of oxides which can contaminate the oil and refrigerant systems.

Note: Use silver soldering with 96% Sn-4% Ag (for example, J.W. Harris Co. Stay Brite®) to replace brazing when the heat from brazing would be detrimental to the immediate or nearby parts.

Examples:

1. Joints next to threaded joints in which the copper or brass threads become too soft and/or Loctite loses its sealing capability due to excess heat.
2. Joints next to valves in which the valves cannot be taken apart or are not recommended for brazing.



Compressor/Motor Reassembly

Final Installation Procedures

After the chiller has been moved to the equipment room and reassembled under Trane supervision, leak testing, and evacuation can be performed by Trane or under Trane supervision. Upon verification of leak tightness, installation can proceed for unit piping, wiring, etc. After installation has been completed, fill out CTV-ADF001-EN (*CenTraVac™ Installation Completion Check Sheet and Request for Trane Service*) to schedule the startup; the chiller commissioning process can be completed by Trane or under the supervision of authorized Trane personnel.

Note: CTV-ADF001-EN is also included in the "Forms" section of CVHE-SVX02F-EN (Installation, Operation, and Maintenance: CVHE, CVHF, CVHG Water-Cooled CenTraVac Chillers with Tracer AdaptiView Control) and CDHF-SVX01E-EN (Installation, Operation, and Maintenance: CDHF and CDHG Water-Cooled CenTraVac Chillers with Tracer AdaptiView Control), or the most recent revisions.

For additional information regarding compressor disassembly and reassembly, refer to CVHE-SB-10B (*General Service Bulletin: Compressor Doweling*), or the most recent version.



Trane optimizes the performance of homes and buildings around the world. A business of Ingersoll Rand, the leader in creating and sustaining safe, comfortable and energy efficient environments, Trane offers a broad portfolio of advanced controls and HVAC systems, comprehensive building services, and parts. For more information, visit www.Trane.com.

Trane has a policy of continuous product and product data improvement and reserves the right to change design and specifications without notice.