

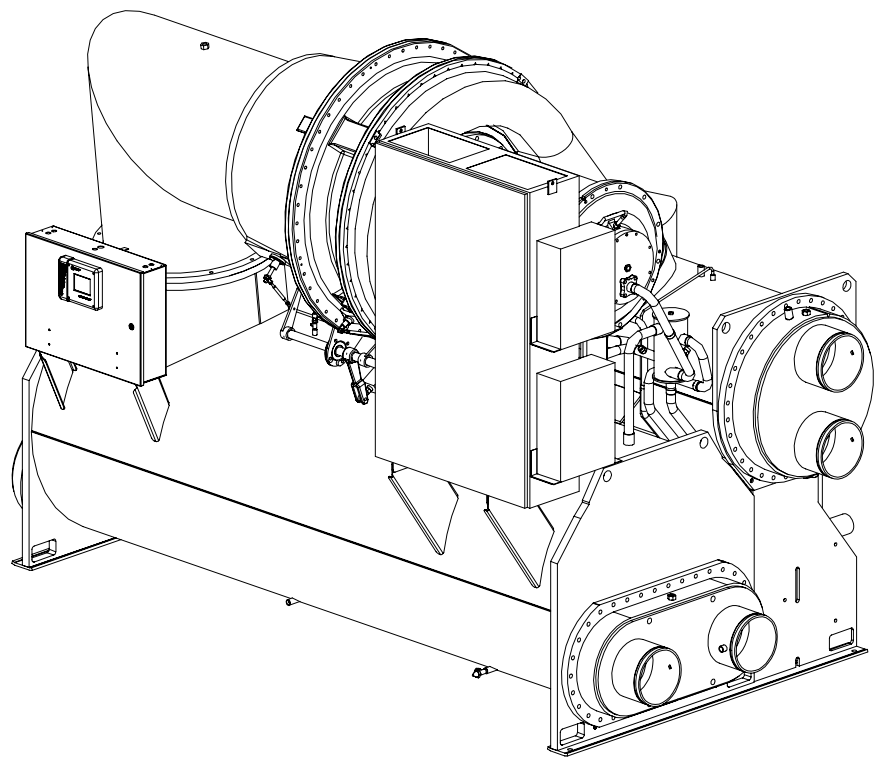

TRANE®

Installation - Electrical Information

Water-Cooled CenTraVac™ With CH530



X39640647050

CVHE-SVN03E-EN



Warnings and Cautions

Notice that warnings and cautions appear at appropriate intervals throughout this manual. Warnings are provided to alert manufactures, designers, installers, servicers, and installing contractors to potential hazards that could result in personal injury or death, while cautions are designed to alert personnel to conditions that could result in equipment damage.

Your personal safety and the proper operation of this machine depend upon the strict observance of these precautions.

NOTICE: Warnings and Cautions appear at appropriate sections throughout this literature. Read these carefully.

⚠ WARNING: Indicates a potentially hazardous situation which, if not avoided, could result in death or serious injury.

⚠ CAUTION: Indicates a potentially hazardous situation which, if not avoided, may result in minor or moderate injury. It may also be used to alert against unsafe practices.

CAUTION: Indicates a situation that may result in equipment or property-damage only accidents.



Contents

Warnings and Cautions	2
General Information.....	4
Trane Supplied Remote Starter.....	5
Customer Supplied Remote Starter	6
Power Supply	8
PFCC	9
Unit Mounted Starter	12
Remote Starter	13
Motor Lugs	16
10kv-13.8kv Medium Voltage Installation.....	17
Wiring Drawings.....	25



General Information

General Requirements

Note: Unit-mounted starters are available as an option on most CVHE, CVHF, and CVHG units with wye delta, and solid-state starters, with nominal voltages of up to 600 volts and unit mounted medium voltage across-the-line starters. While this option eliminates most field-installed wiring requirements, the electrical contractor must still complete the electrical connection for: (1) Power supply wiring to the starter, (2) Other unit control options present, and (3) Any field-supplied control devices.

⚠ WARNING! **Hazardous Voltage w/ Capacitors!**

Disconnect all electric power, including remote disconnects before servicing. Follow proper lockout/tagout procedures to ensure the power cannot be inadvertently energized. For variable frequency drives or other energy storing components provided by Trane or others, refer to the appropriate manufacturer's literature for allowable waiting periods for discharge of capacitors. Verify with an appropriate voltmeter that all capacitors have discharged. Failure to disconnect power and discharge capacitors before servicing could result in death or serious injury.

⚠ WARNING **Rotating Parts!**

During installation, testing, servicing and troubleshooting of this product it may be necessary to measure the speed of rotating components. Have a qualified or licensed service individual who has been properly trained in handling exposed rotating components

perform these tasks. Failure to follow all safety precautions when exposed to rotating components could result in death or serious injury.

As you review this manual, along with the wiring instructions presented in this section, keep in mind that:

Typical field connection requirements for remote-mounted starters are shown at the end of the manual, and summarized in Table 1.

All field-installed wiring must conform to National Electric Code (NEC) guidelines, as well as to any applicable state and local codes. Be sure to satisfy proper equipment grounding requirements per NEC.

All field-installed wiring must be checked for proper terminations, and for possible shorts or grounds.

Note: The typical customer connection diagrams shown in this manual are representative of standard CVHE, CVHF and CVHG units, and are provided only for general reference. Always refer to the actual wiring diagrams that shipped with the chiller for specific as built electrical schematic and connection information.

Do not modify or cut enclosure to provide electrical access. Removable panels have been provided for this purpose. Modify these panels only; away from enclosure. Refer to installation information shipped with the starter or submittal drawings.

CAUTION **Component Damage!**

Remove all debris from inside the starter panel. Failure to do so may result in an electrical short and could cause serious starter component damage.



Trane Supplied Remote Starter

Table 1. CVHE, CVHF, and CVHG standard remote starter field wiring requirements

Power supply wiring (to Starter Panel)	Starter Panel Terminals		
3-Phase Line Voltage: Terminal Block (2TB3 or 2X3)	2X3-L1, L2, L3, and GROUND		
3-Phase Line Voltage: Circuit Breaker	2Q1-L1, L2, L3, and GROUND		
Remote Starter to Chiller Motor Junction Box	T1 through T6		
Starter to UCP 120VAC control wiring	Starter to UCP 120VAC control wiring	Unit Control Panel Terminations	
120VAC Power Supply (from starter to UCP)	2X1-1-1, 2X1-2 2X1-20(Ground)	1X1-1, 1X1-12 1X1-18 (Ground)	#8 gauge minimum 40 amps circuit
High Pressure Cutout to Starter	2X1-4	1X1-4	14 ga.
1Q1 Circuit Breaker to Starter	2X1-6	1X1-3	14 ga.
Oil Pump Interlock	2X1-7, 2X1-8	1A7-J2-4, 1A7-J2-2	14 ga.
Low Voltage Circuits (less than 30VAC)	Starter Panel Terminals	Unit Control Panel Terminations	
Standard Circuits			
Inter Processor Communications (IPC) Remote Mounted	2A1- J3-3 to 4, or 2X1-12 to 13 if present (do not ground shield at starter)	1A1-J5-3 to 4 Shield ground at 1X1- 22(GND) only.	2 wire w/ ground Comm link.

Standard Field Power wiring:

Note: All wiring to be in accordance with National Electrical Code and any local codes.

Reference Field connection diagram 2309-4935 in this manual



Customer Supplied Remote Starter

Table 2. CVHE, CVHF, and CVHG standard customer supplied remote field wiring requirements

Power supply wiring (to Starter Panel)	Starter Panel Terminals		
Starter by others Power wiring: 3-Phase Power Supply Starter and Motor Junction Box Interconnection (Remote starter only)	See "Starter by others" schematic		All wiring to be in accordance with National Electrical Code and any local codes.
Starter provided by others:			
Starter to UCP 120VAC control wiring	Starter to UCP 120VAC control wiring	Unit Control Panel Terminations	
120VAC Power Supply	See "Starter by others" schematic 5X1-1, 5X1-2, 5X1-20 (Ground)	1X1-1, 1X1-12, 1X1-18	#8 gauge minimum 40 amps circuit
Power from UCP 1Q1	5X1-3	1X1-3, 1A23-J6-3	14 ga.
Interlock Relay signal	5X1-4	1A23-J10-1	14 ga.
Start contactor signal	5X1-5	1A23-J8-1	14 ga.
Oil Pump Interlock	5X1-7, 5X1-8	1A7-J2-4, 1A7-J2-2	14 ga.
Run Contactor signal	5X1-10	1A23-J6-12	14 ga.
Transition Complete	5X1-14	1A23-J12-2	14 ga.
Low Voltage Circuits (less than 30VAC)	Starter Panel Terminals	Unit Control Panel Terminations	
Standard Circuits			
Current Transformers* (see table next page)	5CT4- wht, blk 5CT5- wht, blk 5CT6- wht, blk	1A23-J7-1,2 1A23-J7-3,4, 1A23-J7-5,6,	Note: Phasing must be maintained
Potential Transformers	5T17-236,237 5T18-238,239 5T19-240,241	1A23 -J5-1,2, 1A23 -J5-3,4, 1A23 -J5-5,6	Note: Phasing must be maintained

Starter Supplied by Others -Standard Field Power wiring:

Note: All wiring to be in accordance with National Electrical Code and any local codes.

Reference Field Connection Customer Supplied Starter diagram 2309-4936 in this manual

Reference "Starter by Others" Specification available from your local Trane sales office.



Customer Supplied Remote Starter

Table 3. Current transformer and potential transformer wire sizing tables for customer supplied starter to chiller unit control panel starter module 1A23

The maximum recommended wire length for secondary CT leads in a dual CT system are:

Wire AWG (mm2)	Maximum Wire Length Secondary CT Leads	
	Feet	Meters
8 (10)	1362.8	415.5
10 (6)	856.9	261.2
12 (4)	538.9	164.3
14 (2.5)	338.9	103.3
16 (1.5)	213.1	65.0
17 (1)	169.1	51.5
18 (0.75)	134.1	40.9
20 (0.5)	84.3	25.7

Note:

1. Wire lengths are for copper conductors only.
2. Wire lengths are total "one way" distance that the CT can be from the Starter module.

The maximum recommended total wire length for PT's in a single PT system:

Wire Gauge	Max lead length (ft)	Max lead length (m)
8	5339	1627
10	3357	1023
12	2112	643
14	1328	404
16	835	254
17	662	201
18	525	160
20	330	100
21	262	79
22	207	63

The maximum recommended total wire length (to and from) for PT leads in a dual PT system are:

Wire Gauge	Max Wire Length		Max Wire Length	
	Primary (ft)	Primary (m)	Secondary (ft)	Secondary (m)
8	3061	933	711	217
10	1924	586	447	136
12	1211	369	281	85
14	761	232	177	53
16	478	145	111	33
17	379	115	88	26
18	301	91	70	21
20	189	57	44	13
21	150	45	34	10
22	119	36	27	8

Note: These wire lengths are for copper conductors only

Note: The above lengths are maximum round trip wire lengths. The maximum distance the PT can be located from the Starter module is 1/2 of the listed value.

Power Supply

Power Supply Wiring

To assure that power supply wiring to the starter panel is properly installed and connected, review and follow the guidelines outlined below.

3-Phase Power Source

- 1 Verify that the starter nameplate ratings are compatible with the power supply characteristics and with the electrical data on the unit nameplate.
- 2 If the starter enclosure must be cut to provide electrical access, exercise care to prevent debris from falling inside the enclosure. If the starter cabinet has a removable panel, be sure to remove the panel from the unit before drilling holes.

CAUTION Component Damage!

Remove all debris from inside the starter panel. Failure to do so may result in an electrical short and could cause serious starter component damage.

- 3 Use copper conductors to connect the 3-phase power supply to the remote or unit-mounted starter panel.

CAUTION Use Copper Conductors Only!

Unit terminals are not designed to accept other types of conductors. Failure to use copper conductors may result in equipment damage.

- 4 Size the power supply wiring in accordance with the Minimum Circuit Ampacity (MCA) shown on the unit nameplate.
(MCA = (RLA x 1.25) + Control Power Load)
- 5 Make sure that the incoming power wiring is properly phased; each power supply conduit run to the starter must carry the correct number of conductors to ensure equal phase representation. See Figure 1.

Note: Connect L1, L2 and L3 per starter diagram.

- 6 As you install the power supply conduit, make sure that this position does not interfere with the serviceability of any of the unit components, nor with structural members and equipment.
- 7 Tightening torque -follow starter manufactures torque specifications and annual inspection methods.

Also, assure that the conduit is long enough to simplify any servicing that may be necessary in the future (e.g. starter removal).

Note: Use flexible conduit to enhance serviceability and minimize vibration transmission.

Circuit Breakers and Fusible Disconnects

Size the circuit breaker or fuse disconnect in compliance with NEC or local guidelines.

Figure 1. Proper phasing for starter power supply wiring and conduit loading

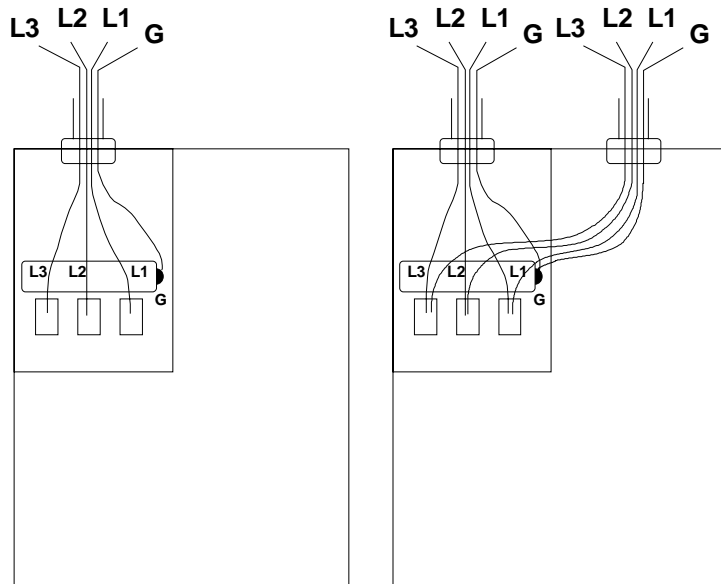



PFCC

Optional PFCCs

Power factor correction capacitors (PFCCs) are designed to provide power factor correction for the compressor motor. They are available as an option.

Note: Remember that the PFCC nameplate voltage rating must be greater than or equal to the compressor voltage rating stamped on the unit nameplate. See Table 4 to determine what PFCC is appropriate for each compressor voltage application.

CAUTION Motor Damage!

PFCCs must be wired into the starter correctly. Failure to do so may cause misapplication of these capacitors and result in a loss of motor overload protection and subsequently cause motor damage.

Table 4. PFCC design voltage sizing per compressor voltage application

PFCC Design Voltage	Compressor Motor Rating (See Unit Nameplate)
240/60 Hz	208V/60 Hz
	380V/60 Hz
	440V/60 Hz
	460V/60 Hz
	480V/60 Hz
600V/60 Hz	575V/60 Hz
	600V/60 Hz
2400V/60 Hz	2300V/60 Hz
	2400V/60 Hz
PFCC Rating	Compressor Motor Rating (See Unit Nameplate)
480V/50 Hz	346V/50 HZ
	380V/50 HZ
	400V/50 HZ
	415V/50 HZ
4160V/60 Hz	3300V/60 Hz
	4160V/60 Hz

Rule 1

Simultaneously disconnect capacitors and load from line power.

If the capacitors are not switched off-line when the load is disconnected, they continue to add capacitance to the electrical distribution system. A “leading” power factor—too much capacitance—may eventually develop. This overcorrection causes poor voltage regulation, i.e., voltage is high when the circuit is unloaded, then drops as loads are added.

Rule 2

Size motor overload protection to account for capacitor-supplied current.

Overloads are typically set to measure the total current drawn by the motor. When PFCCs are used, they become the source of part of that current. If the current they provide isn’t registered by the overload protectors, potentially damaging amperage can reach the motor. The simplest way to ensure that the overloads “see” all current supplied to the motor is to position the PFCCs upstream of the overloads as shown in Figure 2.

If the capacitor connection points are downstream of the overload devices, route the PFCC leads through the overloads as shown in Figure 3. This assures that the overloads register both line and capacitor-supplied current.

Figure 2. PFCCs Installed Downstream of Starter Contactor, Upstream of Overload

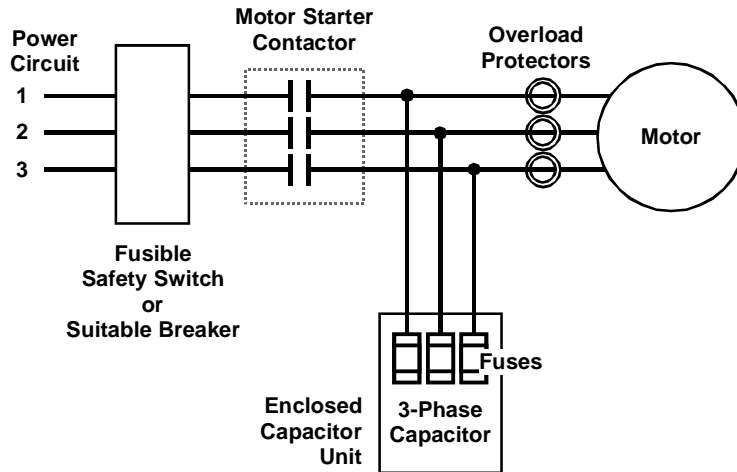
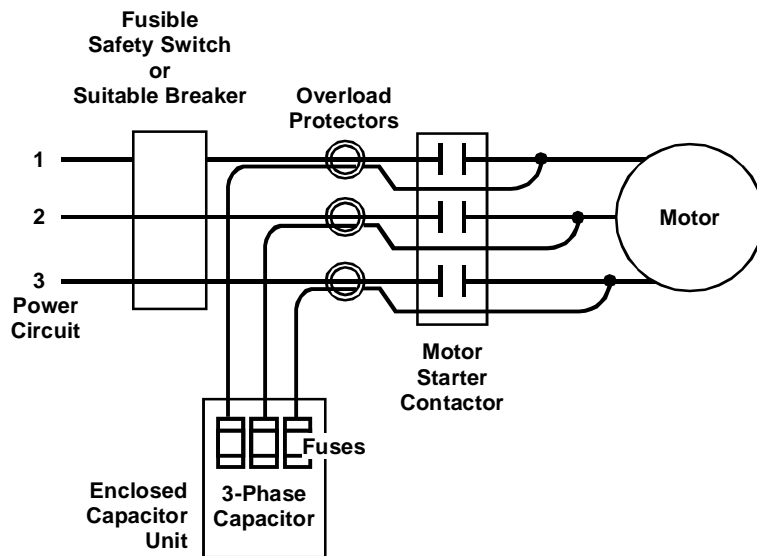

Figure 3. PFCC Wires Routed Through Overload Protectors



Recommended Procedures for Discharging Capacitors

Prior to performing any service on energized equipment, the proper Lockout-Tagout procedures must always be followed. Regardless of the equipment being serviced, the following steps must be taken:

Lockout-Tagout Steps

- 1 Prepare the equipment for shutdown.
- 2 Shut down the equipment.
- 3 Disconnect any energy isolating devices.
- 4 Apply the necessary lockout or tagout devices.
- 5 Render safe all stored or residual energy.
- 6 Verify the isolation and deenergization of the equipment.

Personal Protective Equipment

Always wear appropriate personal protective equipment in accordance with applicable regulations and/or standards to guard against potential electrical shock and flash hazards.

WARNING **Hazardous Voltage!**

Disconnect all electric power, including remote disconnects before servicing. Follow proper lockout/tagout procedures to ensure the power can not be inadvertently energized. Discharge capacitors before servicing. Failure to disconnect power and discharge capacitors before servicing could result in death or serious injury

Verifying Discharge of Capacitors

After following the proper lockout/tagout procedure it is important to verify that all applicable capacitors are discharged and rendered safe. Many capacitors in HVAC equipment include internal bleeder circuits that will automatically discharge the capacitor. **These circuits must be allowed sufficient time to discharge the capacitor prior to performing service.**

While most capacitors contained in Trane equipment include internal bleeder circuits, this is not always the case and these circuits can sometimes fail. In addition, some bleeder circuits can take up to 30 minutes to fully discharge. **It is important to verify that the capacitor has been fully discharged by using a voltmeter that is rated for the voltage of the capacitor being tested.**

WARNING **Live Electrical Components!**

During installation, testing, servicing and troubleshooting of this product, it may be necessary to work with live electrical components. Have a qualified licensed electrician or other individual who has been properly trained in handling live electrical components perform these tasks. Failure to follow all electrical safety precautions when exposed to live electrical components could result in death or serious injury.

Discharging Capacitors

In the event that a capacitor does not have an internal bleeder circuit, the bleeder circuit has failed, or the discharge process is not complete, the capacitor must be discharged properly prior to performing service. In order to safely discharge a capacitor, **a proper capacitor discharge tool must be used.** Screwdrivers and other hand tools are not designed to safely discharge capacitors. Use of these tools may result in death or serious injury and/or equipment damage.

Unit Mounted Starter

Interconnecting Wiring

Typical equipment room conduit layouts with and without unit mounted starters are shown in Figure 4 and Figure 5, respectively.

Important: Keep in mind that the interconnecting wiring between the starter panel, compressor and UCP control panel is factory-installed with unit-mounted starters but must be field-installed when a remote mounted starter is used.

Figure 4. Typical equipment room layout with unit-mounted, Wye-Delta

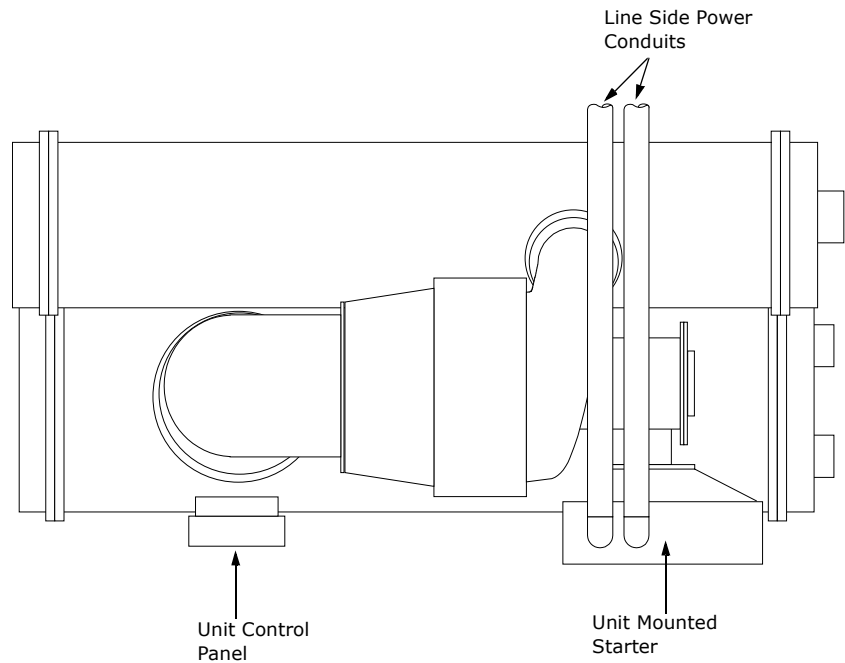

Note:
See Starter submittal drawing for location of incoming wiring to the starter.

Remote Starter

Figure 5. Typical equipment room layout with remote-mounted Wye-Delta starter

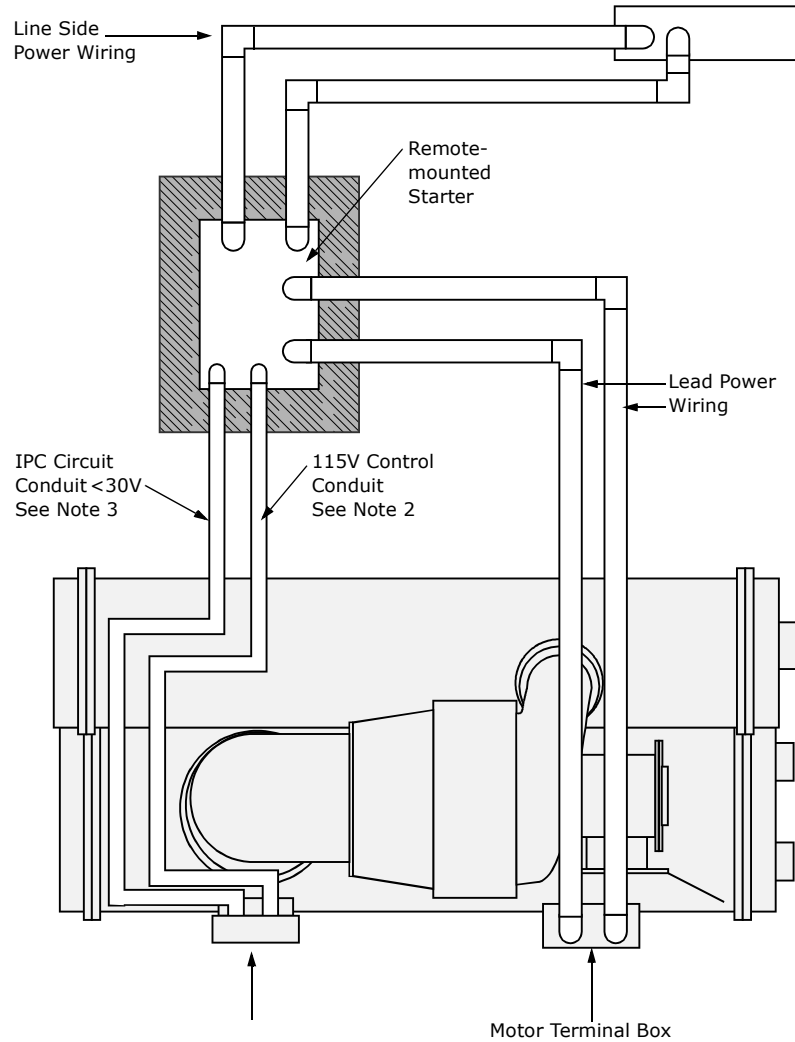

Notes:

1. Refer to the unit field connection diagram for approximate UCP knockout locations.
2. 115-volt conduit must enter the higher than 30 Vdc Class I portion of the unit control panel.
3. IPC circuit conduit must enter the Low Voltage Class II portion of the UCP. (1000 ft. max)
4. See starter submittal drawing for location of incoming wiring to the starter.

Starter to Motor (Remote-Mounted Starters Only)

Ground Wire Terminal Lugs

Ground wire lugs are provided in the motor terminal box and in the starter panel.

Terminal Clamps

Terminal clamps are supplied with the motor terminals to accommodate either bus bars or standard motor terminal wire lugs.

Terminal clamps provide additional surface area to minimize the possibility of improper electrical connections.

Wire Terminal Lugs

Wire terminal lugs must be field supplied.

- 1 Use field-provided crimp-type wire terminal lugs properly sized for the application.

Note: Wire size ranges for the starter line and load-side lugs are listed on the starter submittal drawings supplied by the starter manufacturer or Trane. Carefully review the submitted wire lug sizes for compatibility with the conductor sizes specified by the electrical engineer or contractor.

- 2 A terminal clamp with a 3/8" bolt is provided on each motor terminal stud; use the factor-supplied Belleville washers on the wire lug connections.

Figure 6 illustrates the juncture between a motor terminal stud and terminal clamp.

- 3 Tighten each bolt to 24 foot-pounds.
- 4 Install but do not connect the power leads between the starter and compressor motor. (These connections will be completed under supervision of a qualified Trane service engineer after the pre-start inspection.)

CAUTION Component Damage!

Ensure the power supply wiring and output to motor wiring are connected to the proper terminals. Failure to do so will cause catastrophic failure of the starter and, or motor.

Bus Bars

Install the bus bars between the motor terminals when a low-voltage "across-the-line," "primary reactor/resistor," "auto transformer" or customer-supplied solid-state, or customer-supplied AFD.

Be sure to bus motor terminal T1 to T6, T2 to T4, and T3 to T5.

Note: Bus bars are not needed in medium-voltage applications since only 3 terminals are used in the motor and starter.

When attaching starter leads to 6.6-7kv motor terminals, the 1/2"-13 brass jam nuts should be tightened to a maximum torque of 18 to 22 ft lb. Always use a second wrench to 'back-up' the assembly and prevent the application of excessive torque to the terminal shaft.

Starter to UCP (Remote-Mounted Starters Only)

Electrical connections required between the remote-mounted starter and the Unit Control Panel (UCP) are shown in an example of a point-to-point starter-to-UCP connection diagram as shown at the end of the manual.

Note: Install control voltage conduit into control voltage section of chiller control panel and starter panel. Do not route with low voltage (30 volts) conduit wires.

When sizing and installing the electrical conductors for these circuits, follow the guidelines listed.

Unless otherwise specified use 14 ga. wire for 120 V control circuits.

CAUTION **Component Damage!**

Remove all debris from inside the starter panel. Failure to do so may result in an electrical short and could cause serious starter component damage.

- 1 If the starter enclosure must be cut to provide electrical access, exercise care to prevent debris from falling inside the enclosure. Do not cut AFD enclosure.
- 2 Use only shielded twisted pair for the interprocessor communication (IPC) circuit between the starter and the UCP on remote mounted starters. Recommended wire is Beldon Type 8760, 18 AWG for runs up to 1000 feet.

***Note:** The polarity of the IPC wire pair is critical for proper operation.*

- 3 Separate low-voltage (less than 30V) wiring from the 115V wiring by running each in its own conduit.
- 4 As you route the IPC circuit out of the starter enclosure, make sure that it is at least 6" from all wires carrying a higher voltage.

- 5 For UCP IPC shielded twisted pair wiring, the shield should be grounded on one end only at UCP at 1X1-G. The other end should be un-terminated and taped back on the cable sheath to prevent any contact between shield and ground. (1000 ft. max)
- 6 Oil Pump Interlock - All starters must provide an interlock (N.O.) contact with the chiller oil pump connected to the UCP at Terminals 1A7-2-4 and 1A7-J2-2 (14 ga.) The purpose of this interlock is to power the oil pump on the chiller in the event that a starter failure, such as welded contacts, keeps the chiller motor running after the controller interrupts the run signal.

CAUTION **Electrical Noise!**

Maintain at least 6 inches between low-voltage (<30V) and high voltage circuits. Failure to do so could result in electrical noise that may distort the signals carried by the low voltage wiring, including the IPC.

Motor Lugs

Figure 6. Terminal stud, clamp and lug assembly

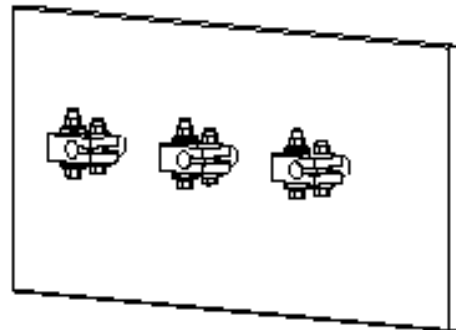
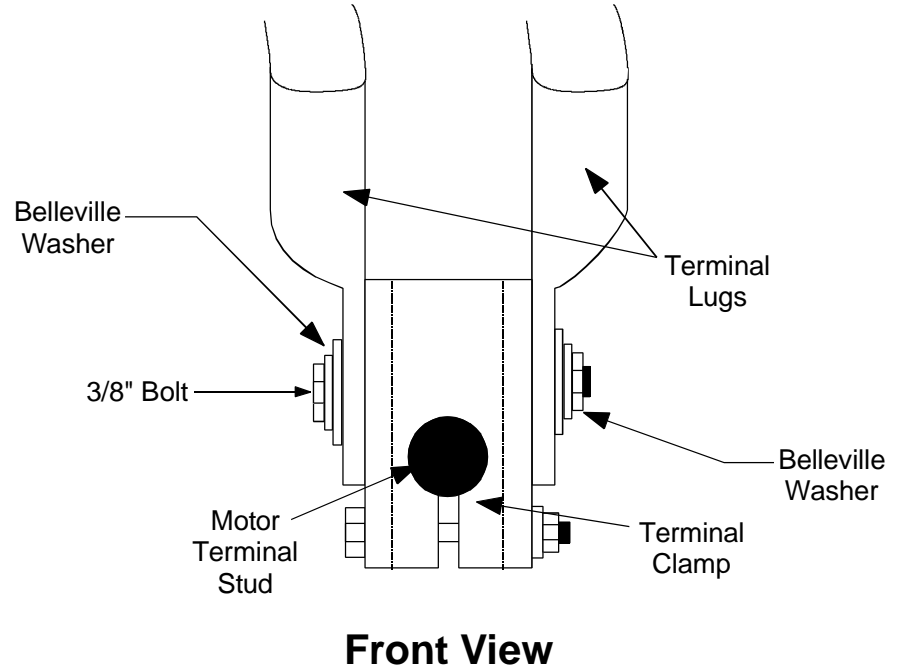

Mid Voltage
 RXL RATR RPIR CXL CATR CPIR
 2300 volts to 4160 volts



10kv-13.8kv Medium Voltage Installation

⚠ WARNING **Hazardous Voltage!**

Disconnect all electric power, including remote disconnects before servicing. Follow proper lockout/tagout procedures to ensure the power can not be inadvertently energized. Failure to disconnect power before servicing could result in death or serious injury.

All electrical circuits shall be treated as energized until all lockout-tagout procedures are in place and the circuit has been tested to verify that it is de-energized. The medium voltage motor terminal box cover must not be removed if power is present, or if there is a possibility that power may be present. Working on energized medium voltage circuits is not an approved practice for normal HVAC maintenance or service.

10kv - 13.8kv Medium Voltage Motor

The medium voltage motor applied by Trane is a 3-phase form wound hermetic design with 3 motor leads brought through the motor casing with sealed terminals. The motor is suitable for remote mounted across-the-line (including circuit breaker starting), primary reactor, auto-transformer, or solid-state starting. Refer to the unit nameplate for motor data including RLA, LRA, etc.

In all cases of non-Trane supplied starters, the Trane Engineering Specification for CH530 Starter By Others (6516-0513) must be followed in order to ensure proper function and protection of the chiller. A disconnecting means and short-circuit protection must be installed ahead of the starter, unless they are included as part of the starter. Trane assumes no responsibility for the design, documentation, construction, compatibility, installation, start-up, or long term support of starters provided by others.

Motor Terminal Box

A large steel motor terminal box is provided to allow for the field connection of the motor power supply wire to the motor. The motor terminal box cover weight is 55 lb (25 kg). Two 7/8" lifting holes are provided in the cover.

If the box must be removed for clearance during chiller installation, the box without the cover weighs 215 lb (98 kg). Two 3/8"-16 weld-nuts are provided on the top of the terminal box to allow the use of properly rated lifting d-rings.

Note: If the box is removed for installation purposes, the motor terminals **MUST** be protected against impact or stress damage. Field fabrication of a cover or guard is required.

The motor terminal box is large enough to accommodate the use of stress cones. If conduit is applied a flexible connection of the conduit to the box should be made to allow for unit serviceability and for vibration isolation. The cable should be supported or protected against abrasion and wear on any edges or surfaces. Cable or conduit openings can be cut at any location in the box sides, top, or bottom for cable entry. Always ensure that debris does not remain in the box after cutting cable entry holes.

Figure 7. 10kv - 13.8kv motor terminal box

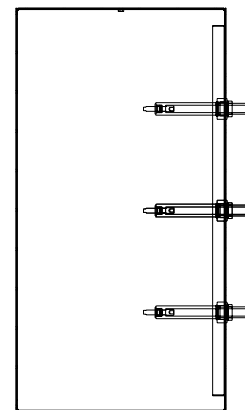
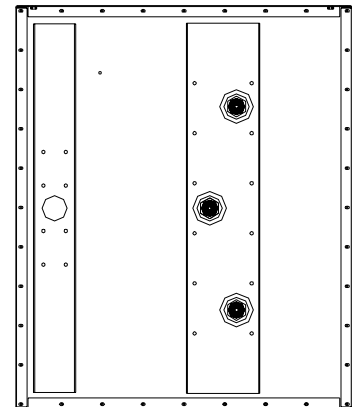

Motor Supply Wiring

Motor circuit wire sizing by the installer must be made in accordance with the National Electric Code or any other applicable codes. All wiring to the CenTraVac motor must be shielded copper, with insulation rated to a minimum of 15kv.

Three terminals are provided on the chiller for the connection of power to the motor from the starter. Power leads to motors must be in multiples of 3, with equal phase representation in all conduits or wire trays. Wire size is typically determined using any applicable local code requirements or National Electric Code (NEC) recommendations. To limit the effects of corona or ionization with cables carrying more than 2000v we recommend that the power cable have a metallic shield, unless the cable is specifically listed or approved for non-shielded use. If the cable is shielded, the shielding must be grounded at one end (grounding is typically done at the starter or supply end).

Motor Terminals - Field provided ring type lugs, with no sharp edges or corners, must be used by a qualified installer to connect the power wiring to the motor terminals. Follow all instructions provided with the field provided lugs to ensure proper connections. Stress reliefs may be used. The use of stress cones is highly recommended to reduce and control longitudinal and radial electrical stresses at the cable ends. Prior to assembly the terminal stud, nuts, and lug should be inspected and cleaned to ensure they are not damaged or contaminated. The motor terminal has a copper shaft that is threaded 9/16" - 18 UNF2A. Brass nuts are provided on the motor terminals to retain the lugs, and the final connection should be tightened to 22-25 ft lb using a 7/8" socket on a torque wrench.

Important: Do not apply torque to the motor terminal when tightening lugs, always use a second wrench to "back-up" the assembly and prevent the application of torque to the terminal shaft.

Care must be taken while routing the incoming cables to ensure that cable loads or tensions are not applied to the terminal or premature terminal failure could result.

Ground Wire Terminal Lug - A ground wire lug is provided in the motor terminal box to allow the field connection of an earth ground. The lug will accept a field supplied ground wire of #8 to #2 AWG size.

After the field connection of wiring is complete inspect and clean the motor terminals and motor housing, and remove any debris before reinstalling the motor terminal box cover.

The cover must be re-installed onto the motor terminal box and all bolts installed. Do not operate the chiller with the motor terminal box cover removed or with any loose or missing cover bolts.



Field Control Panel Signal Wiring

Table 5.

Standard Control Circuits: UCP Control Wiring (120 VAC)	Unit Control Terminations	Included in Factory Package	Input or Output Type	All wiring to be in accordance with National Electrical Code and any local codes. Contacts
Chilled Water Flow Proving Input	1X1-5 to 1A6-J3-2	Std.	Binary Input	Normally Open, closure with flow
Condenser Water Flow Proving Input	1X1-6 to 1A6-J2-2	Std.	Binary Input	Normally Open, closure with flow
Chilled Water Pump Relay Output	1A5-J2- 4 to 6	Std.	Binary Output	Normally Open
Condenser Water Pump Relay Output	1A5-J2-1 to 3	Std.	Binary Output	Normally Open
Optional Control Circuits (120 VAC)				
Alarm Relay MAR (Non-Latching) Output	1A8-J2-1 to 3	OPST	Binary Output	Normally Open
Limit Warning Relay Output	1A8-J2-4 to 6	OPST	Binary Output	Normally Open
Alarm Relay MMR (Latching) Output	1A8-J2-7 to 9	OPST	Binary Output	Normally Open
Compressor Running Relay Output	1A8-J2-10 to 12	OPST	Binary Output	Normally Open
Maximum Capacity Relay Output	1A9-J2-1 to 3	OPST	Binary Output	Normally Open
Head Relief Request Relay Output	1A9-J2-4 to 6	OPST	Binary Output	Normally Open
Purge Alarm Relay Output	1A9-J2-7 to 9	OPST	Binary Output	Normally Open
Ice Making Relay Output	1A5-J2-10 to 12	EXOP	Binary Output	Normally Open
Free Cooling Relay Output	1A11-J2-4 to 6	FRCL	Binary Output	Normally Open
Standard Low Voltage Circuits Low Voltage Circuits (less than 30VAC)				
External Auto Stop Input	1A13-J2-1 to 2	Std.	Binary Input	Closure required for normal operation
Emergency Stop Input	1A13-J2-3 to 4	Std.	Binary Input	Closure required for normal operation
Optional Low Voltage Circuits				
External Base Loading Enable Input	1A18-J2-1 to 2	EXOP	Binary Input	Normally Open
External Hot Water Control Enable Input	1A18-J2-3 to 4	EXOP	Binary Input	Normally Open
External Ice Machine Control Enable Input	1A19-J2-1 to 2	EXOP	Binary Input	Normally Open
External Free Cooling Input Enable Input	1A20-J2-1 to 2	FRCL	Binary Input	Normally Open
RLA Compressor Output	1A15-J2-1 to 3	GBAS or CDRP	Analog Output	2-10 vdc
External Condenser Pressure Output	1A15-J2-4 to 6	GBAS or CDRP	Analog Output	2-10 vdc
External Current Limit Setpoint Input	1A16-J2-2 to 3	GBAS	Analog Input	2-10 vdc, or 4-20 mA
External Chilled/Hot Water Setpoint Input	1A16-J2-5 to 6	GBAS	Analog Input	2-10 vdc, or 4-20 mA
External Base Load Setpoint Signal Input	1A17-J2-2 to 3	EXOP	Analog Input	2-10 vdc, or 4-20 mA
Generic Refrigerant Monitor input	1A17-J2-5 to 6	EXOP	Analog Input	2-10 vdc, or 4-20 mA
Outdoor Air Temperature sensor	IPC bus Connection and sensor	CWR	Communication and sensor.	
Tracer Comm Interface	1A14-J2-1(+) to 2(-) 1A14-J2-3(+) to 4(-)	TRIMM or LCI-C	Communication to Tracer	



UCP Electrical Specifications

Following is a requirements list for the UCP in the control panel:

Note that the control panel is designed to receive input from the secondary of a power transformer in the starter panel.

- 1 Nominal Voltage: 115/110 VAC, 60/50 Hz with operating range of 98 to 127 VAC, inclusive.
- 2 Maximum VA: 4K VA (40-amp fuse) for units with the refrigerant pump.
- 3 Power input wiring must be at least 6" (152 mm) from low voltage, less than 30V wiring.
- 4 All signal inputs are low-voltage less than 30V.
- 5 UCP Storage Range: -40°F to 158°F (-40°C to 70°C) i.e., not applicable for chiller.

Water Pump Interlock Circuits and Flow Switch Input

Chilled Water Pump

Wire the evaporator water pump contactor (5K1) to a separate 120 volt single phase power supply with 14 AWG, 600 volt copper wire, then connect this circuit to 1A5-J2-6. Then use 1A5-J2-4 120 VAC output to allow the UCP to control the evaporator water pump, or wire the 5K1 contactor to operate remotely and independently of the UCP.

Chilled Water Proof of Flow

Wire the auxiliary contacts of the evaporator water pump contactor (5K1) in series with the flow switch (5S1) installed in the evaporator supply pipe. Use 14 AWG, 600-volt copper wire.

Connect this circuit to UCP terminals 1X1-5 to 1A6-J3-2.

When installed properly, the chilled water interlock circuit will only allow compressor operation if the evaporator pump is running and providing at least the minimum water flow required.

Condenser Water Pump

Wire the condenser water pump contactor (5K2) to a separate 120-volt, single phase power supply with 14 AWG, 600-volt copper wire; then connect this circuit to UCP terminals 1A5-J2-3. Then use 1A5-J2-1 120 VAC output to allow UCP to control the condenser pump.

Condenser Water Proof of Flow

Next, use 14 AWG, 600-volt copper wire to connect the auxiliary contacts of the condenser water pump contactor (5K2) in series with the flow switch (5S2) installed in the condenser supply pipe.

Connect this circuit to UCP terminals 1X1-6 to 1A6-J2-2.

When installed properly, the condenser water lock circuit will only allow the compressor to operate if the condenser pump is running and providing at least the minimum water flow required.

Temperature Sensor Circuits

All temperature sensors are factory installed except the optional outdoor air temperature sensor. This sensor is required for the outdoor air temperature type of chilled water reset. Follow the guidelines below to locate and mount the outdoor air temperature sensor. Mount the sensor probe where needed, however, mount the sensor module in the UCP.

CWR - Outdoor Option

The outdoor temperature sensor similar to the unit mounted temperature sensors in that it consists of the sensor probe and the module. A four-wire IPC bus is connected to the module for 24 vdc power and the communications link.

We recommend mounting the sensor module within the UCP and the sensor two wire leads be extended and routed to the outdoor temperature sensor probe sensing location. This assures the four wire IPC bus protection and provides access to the module for configuration at start-up.

The sensor probe lead wire between the sensor probe and the module can be separated by cutting the two wire probe lead leaving equal lengths of wire on each device; the sensor probe and the sensor module. Note this sensor and module are matched and must remain together or inaccuracy may occur. These wires can then be spliced to with two 14-18 AWG 600V wires of sufficient length to reach the desired outdoor location, maximum length 1000 feet (305 meters). The module four-wire bus must be connected to the UCP four-wire bus using the Trane approved connectors provided.

The sensor will be configured (given its identity and become functional) at start-up when the serviceman performs the start-up configuration.

It will not be operational until that time.

Note: *If shielded cable is used to extend the sensor leads, be sure to tape off the shield wire at the junction box and ground it at the UCP. If the added length is run in conduit, do not run them in the same conduit with other circuits carrying 30 or more volts.*

Note: *Maintain at least 6 inches between low-voltage (<30v) and high voltage circuits. Failure to do so could result in electrical noise that may distort the signals carried by the low-voltage wiring, including the IPC.*

Optional Relay Circuits

Optional Control and Output Circuits

Install various optional wiring as required by the owner's specifications.

TRMM or LC1-C

Optional Tracer Communication Interface

This control options allows the UCP to exchange information such as chiller status and operating set points with a Tracer system.

Figure 10 illustrates how such a communication/control network might appear.

Note: *The circuit must be run in separate conduit to prevent electrical noise interference.*

Additional information about the Tracer Comm option is published in the installation manual and operator's guide that ships with the Tracer.

Unit Start-Up

All phases of initial unit start-up must be conducted under the supervision of a qualified local service engineer.

This includes pressure testing, evacuation, electrical checks, refrigerant charging, actual start-up and operator instruction.

Advance notification is required to assure that initial start-up is scheduled as close to the requested date as possible.

Starter Module Configuration

The starter module configuration settings will be checked (and configured for Remote Starters) during start-up commissioning. To configure starter module, and perform other starter checks, it is recommended that the line voltage three phase power be turned off and secured (locked out), and then a separate source control power (115 vac) be utilized to power up the control circuit. To do this, remove control coil circuit fuse, typically 2F4, and then connect separate source power cord to starter terminal block 2X1-1 (H), 2X1-2 (N), and Ground. Use the "as-built starter schematic" to assure correct fuse and terminals. Verify correct fuse is removed, control circuit connections are correct, then apply the 115 vac separate source power to service the controls.

Forms Information

Samples of start-up and operating forms along with other helpful forms are found in the Operation Maintenance manual which can be obtained from the nearest Trane office.

It is recommended that the serviceman contact the local Trane office to obtain the most recent printing date of the form. The forms in the operation and maintenance manual are only current at the time of printing of the manual.

After obtaining the most recent form, complete all information and forward it to your local Trane office.

Figure 8. Standard Enclosure

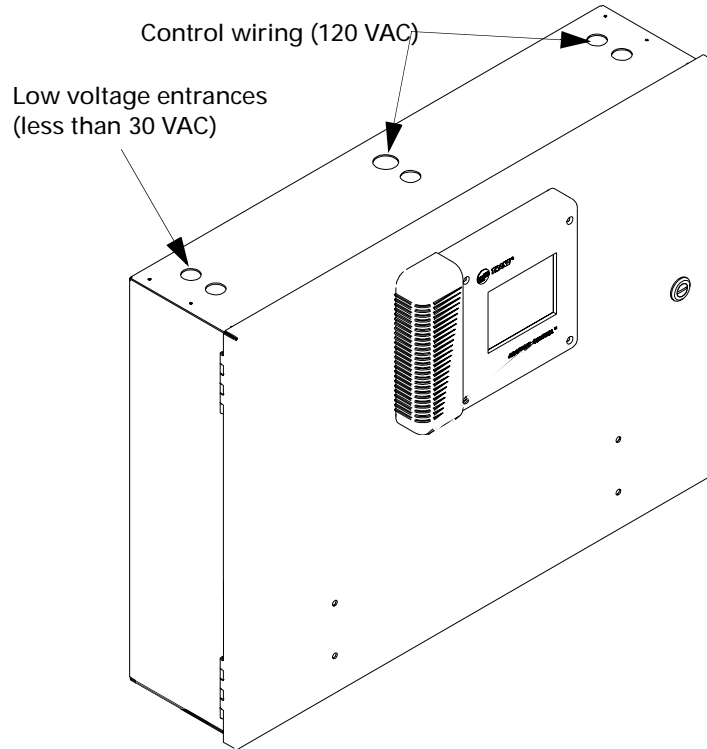

Note: UCP control wiring (120 VAC) must not be routed with low voltage circuits (less than 30 VAC). Conduit access holes are furnished in the top of the unit control panel. Use the left holes for low voltage wiring, and use center and right hand holes for control (120 VAC) wiring.

Note: The wire is retained in the clamp by the force of the spring which pushes the wire against the connecting bar. Use care to ensure full insertion of screwdriver into terminal block wire release mechanism. Proper tool engagement is required to release the tension for wire insertion.

Control Panel Internally mounted devices

For visual identification Internal Control Panel mounted devices are identified by their respective schematic designation number. Control panel items are marked on the inner back panel in the control panel. Figure 7 illustrated below, identifies these devices. The Control Panel Devices table corresponds to the same device designators (see right hand column). Optional controls are present when a specific optional controls package is specified, as listed in the second column.

Optional controls packages are;
 OPST Operating Status, GBAS
 Generic Building Systems, EXOP
 Extended operation, CDRP
 Condenser Pressure, TRMM Tracer
 communications, WPSR Water Flow
 Pressure sensing, FRCL Free
 Cooling, HGBP Hot Gas Bypass, and
 EPRO Enhanced Protection.

Figure 20 illustrates the Control Panel Components Layout.

Modules 1A1, 1A3, 1A4, 1A5, 1A6, 1A7, and 1A13 are standard and present in all configurations. Other Modules vary depending on machine optional devices.

Figure 9. Control panel components layout

CH530 MAIN CONTROL PANEL ASSY
DEVICE DESIGNATIONS AND CIRCUIT DESCRIPTIONS
CVHE-CVHF-CVHG SIMPLEX UNITS

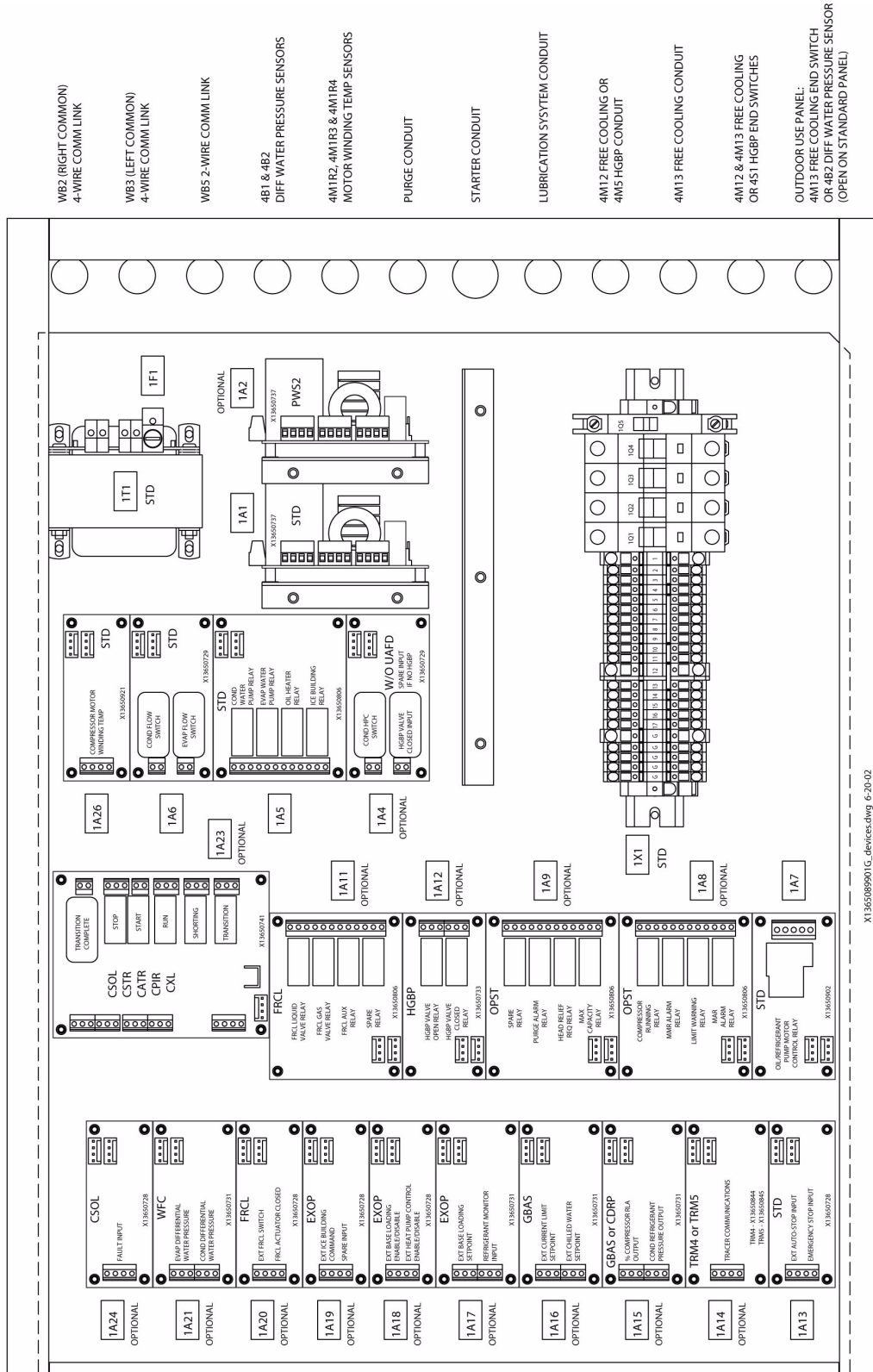

WB2 (RIGHT COMMON)
4-WIRE COMM LINK

WB3 (LEFT COMMON)
4-WIRE COMM LINK

WB5 2-WIRE COMM LINK

4B1 & 4B2
DIFF WATER PRESSURE SENSORS

4M1R2, 4M1R3 & 4M1R4
MOTOR WINDING TEMP SENSORS

PURGE CONDUIT

STARTER CONDUIT

LUBRICATION SYSTEM CONDUIT

4M12 FREE COOLING OR
4M5 HGBP CONDUIT

4M13 FREE COOLING CONDUIT

4M12 & 4M13 FREE COOLING
OR 451 HGBP END SWITCHES

OUTDOOR USE PANEL:
4M13 FREE COOLING END SWITCH
OR 4B2 DIFF WATER PRESSURE SENSOR
(OPEN ON STANDARD PANEL)

X1365089901G_device.dwg 6-20-02

Figure 10. Illustrated communication/control network to chiller with CH530

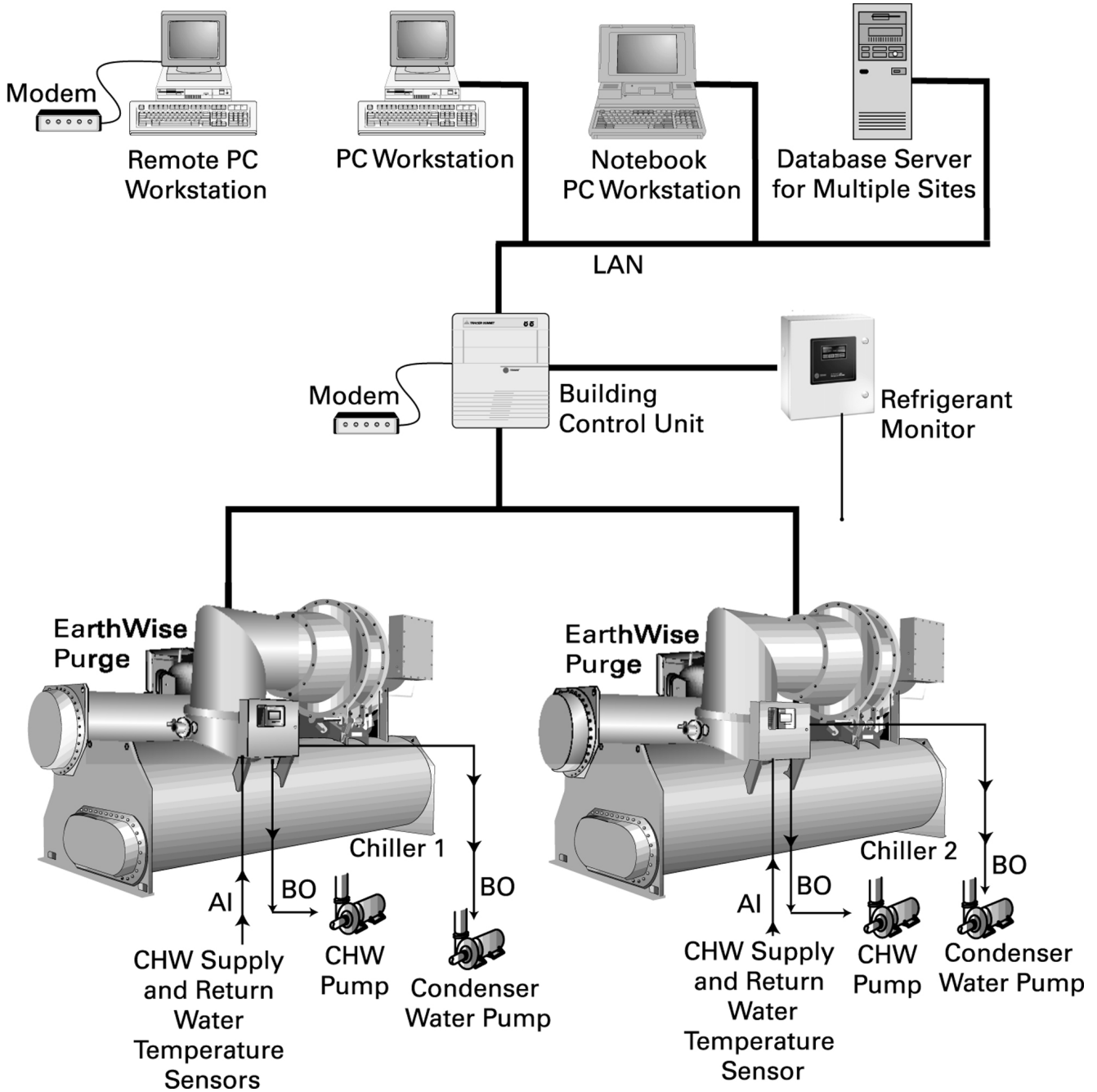



Wiring Drawings

Schematic Wiring Drawings

The following pages consist of *typical* wiring drawings for an CVHE, CVHF or CVHG chiller. However, please refer to the submittals and drawings that actually shipped with the unit.

Refer to the chiller operation and maintenance manual for an example of a typical sequence of operation for a Unit Mounted Wye-Delta Starter.

In the starter drawings, shown in this manual, all starter variables are the same in the Sequence of Operation except the Maximum Acceleration Time.

Table 6 provides a listing of included schematics, connection diagrams and field wiring drawings to follow.

Table 6 also shows variables of the Maximum Acceleration Time for all starter drawings in this manual.

Table 6. Wiring addendum

Type of Drawing	Drawing Number	Maximum Acceleration Time (seconds)	Page #
Field Wiring Layout Drawings			
Legend (Unit Mounted Wye-Delta Starter)	2309-2182		80-81
Unit Mounted Wye-Delta Starter (USTR)	2309-7945	27	26-27
Unit Mounted Solid-State Starter (USID)	2309-7962	15	28-29
Unit Mounted Across-the-Line (UXL)	2309-7996	6	30-31
Unit Mounted Adaptive Frequency Drive (UAFD)	2309-8033 2309-8034	30	32-33 34-35
Unit Mounted Auto Transformer Start (UATR)	2309-7974	11	36-37
Unit Mounted Primary Transformer (UPIR)	2309-7985	11	38-39
Remote Wye-Delta Starter (RSTR)	2309-7952	27	40-41
Remote Mounted Solid-State Starter (FSID, WSID)	2309-7960	15	42-43
Remote Across-the-Line Starter (RXL)	2309-7994	6	44-45
Remote Primary Reactor Starter (RPIR)	2309-7983	11	46-47
Remote Auto Transformer Starter (RATR)	2309-7972	11	48-49
Customer Supplied Wye-Delta Starter (CSTR)	2309-7998	27	50-51
Customer Supplied Primary Reactor or Auto Transformer Starter (CATR, CPIR)	2309-8012	11	52-53
Customer Supplied Across-the-Line Starter (CXL)	2309-8022	6	54-55
Customer Supplied Solid-State Starter (CSOL)	2309-8002	20	56-57
Purge Schematic	2309-8041	-	58-59
Unit Controls Schematic	2309-8036	-	60-61
System Controls Schematic	2309-8039	-	62-63
Optional Ctonrol Schematic	2309-8043	-	64-65
Connection Diagrams			
Standard Connection Diagram Panel with Options	2309-2178	-	66-67
Field Connection Trane Starter (LV)	2309-2169	-	68-69
Field Connection Trane Starter (MV)	2309-2171	-	70-71
Customer Supplied Starter (LV)	2309-2173	-	72-73
Customer Supplied Starter (MV)	2309-2175	-	74-75
Trane Supplied AFD	2309-2177	-	76-77
Unit Wiring	2309-2181	-	78-79

Note: These are typical drawings only. Refer to specific as-built schematics for actual unit drawings which represent the unit wiring as shipped.

Note: Contact your local Trane representative for all other schematics, wiring diagrams and/or connection diagrams not listed.

2309-7945

Unit mounted wye-delta starter with optional GRDF and PFCC, without optional CPTR

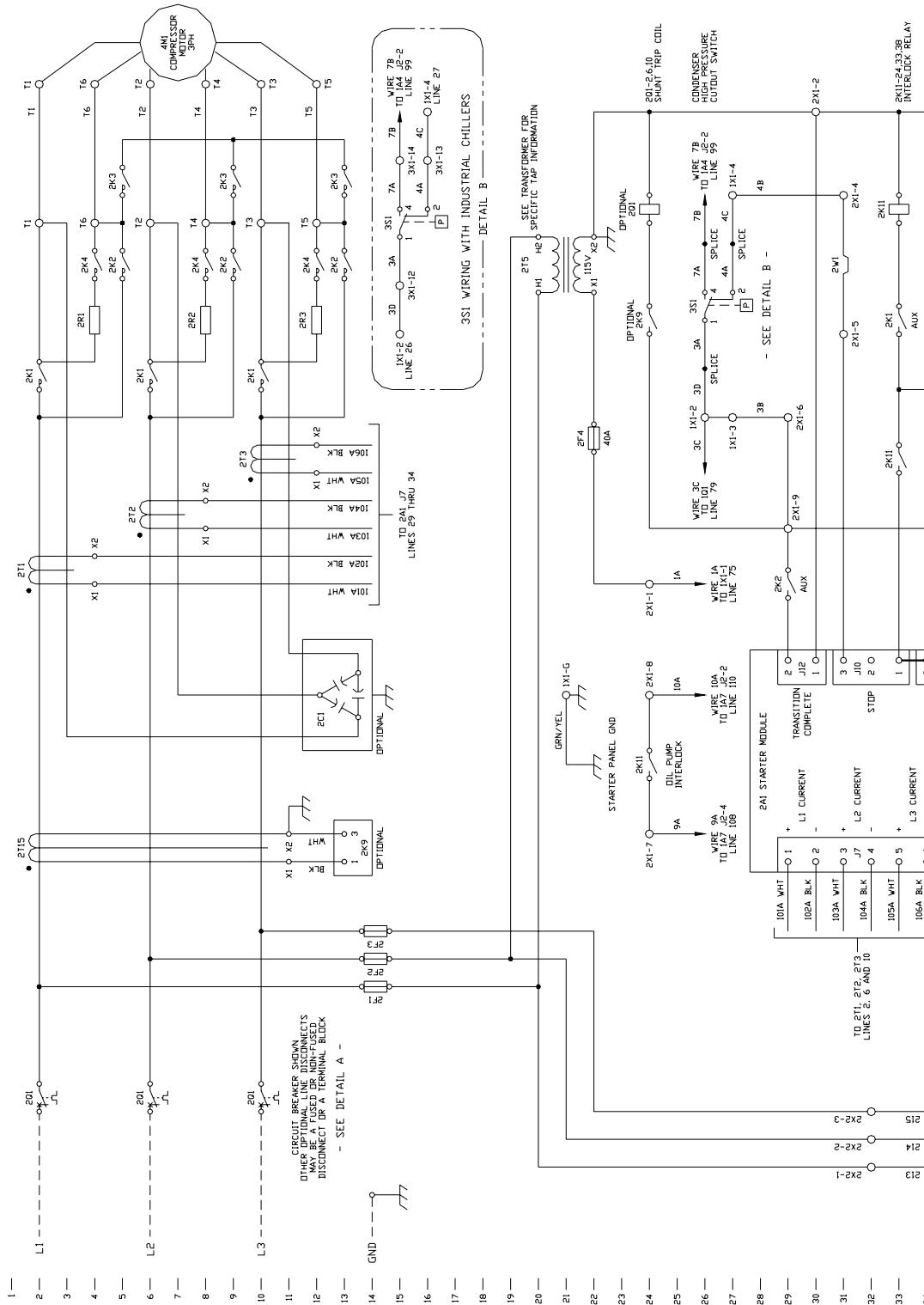

2309-7996 (Con't)

Unit mounted across the line starter standard 3-lead motor connection with optional GRDF and PFCC, without optional CPTR

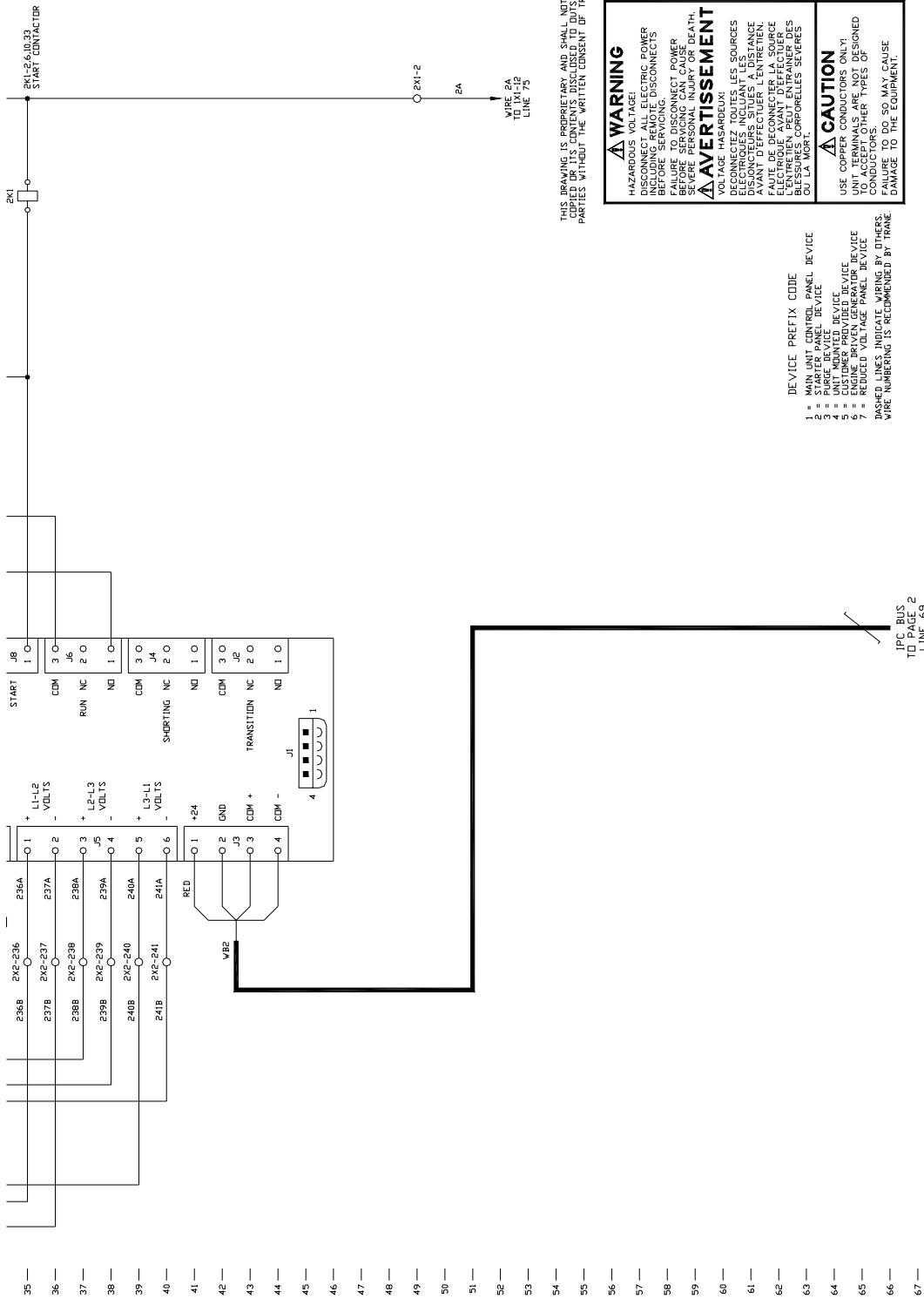

2309-8033

Unit mounted adaptive frequency drive 405-608A LiquiFlo 2, Frame 3

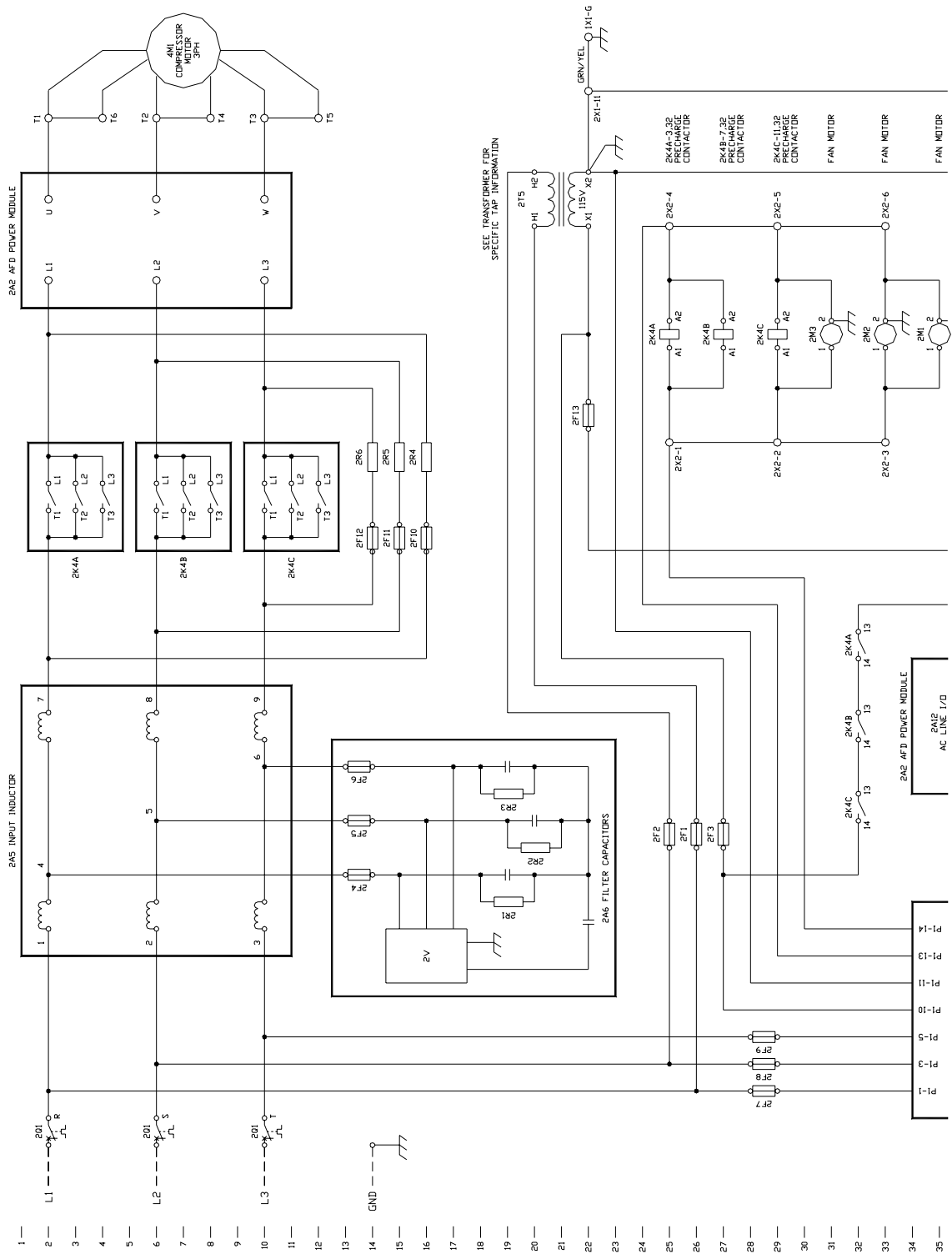

2309-8034
Unit mounted adaptive frequency drive 810-1210A LiquiFlo 2, Frame 4

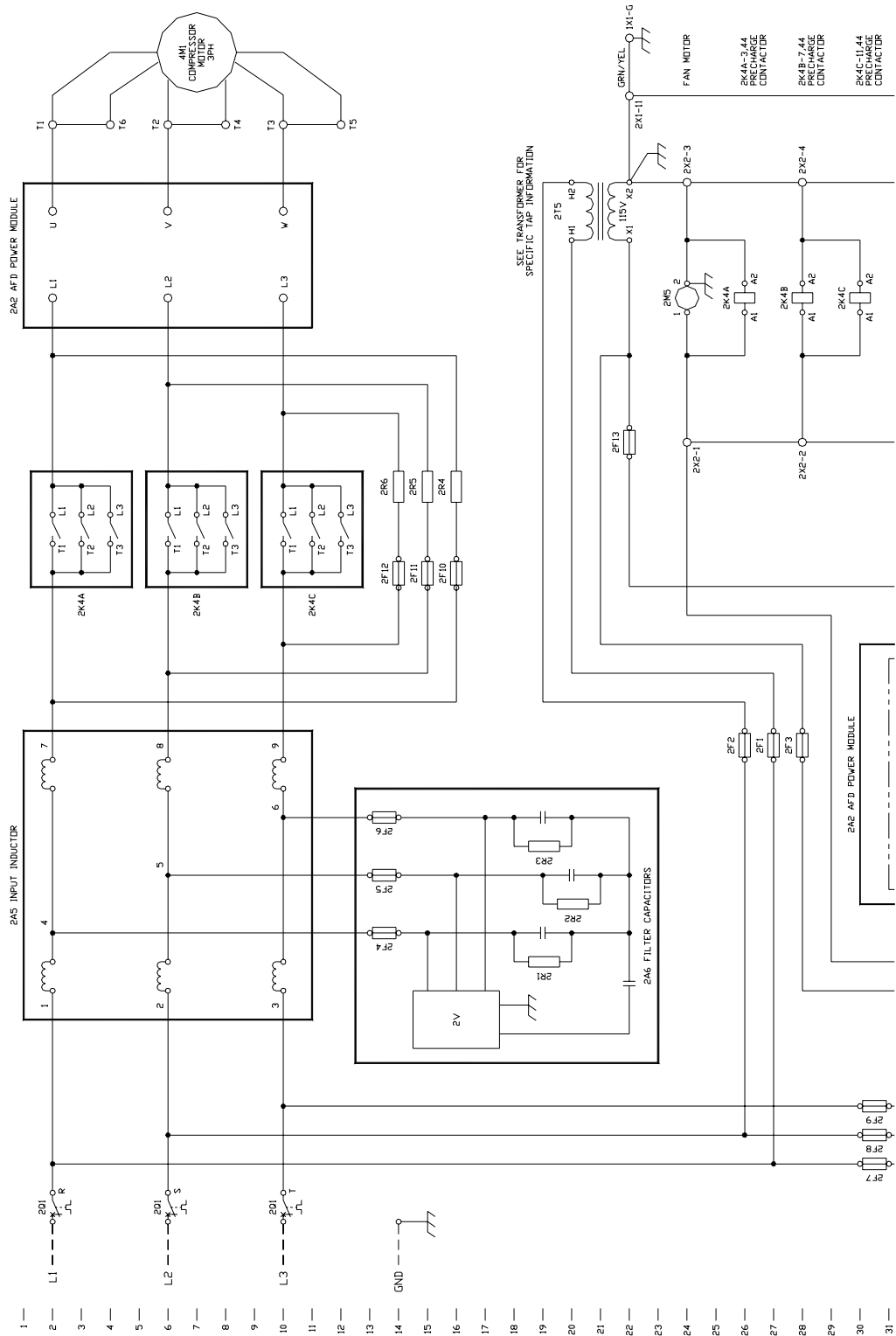

2309-7974 (Con't)

Unit mounted auto-transformer starter standard 3-lead motor connection with optional GRDF and PFCC, without optional CPTR

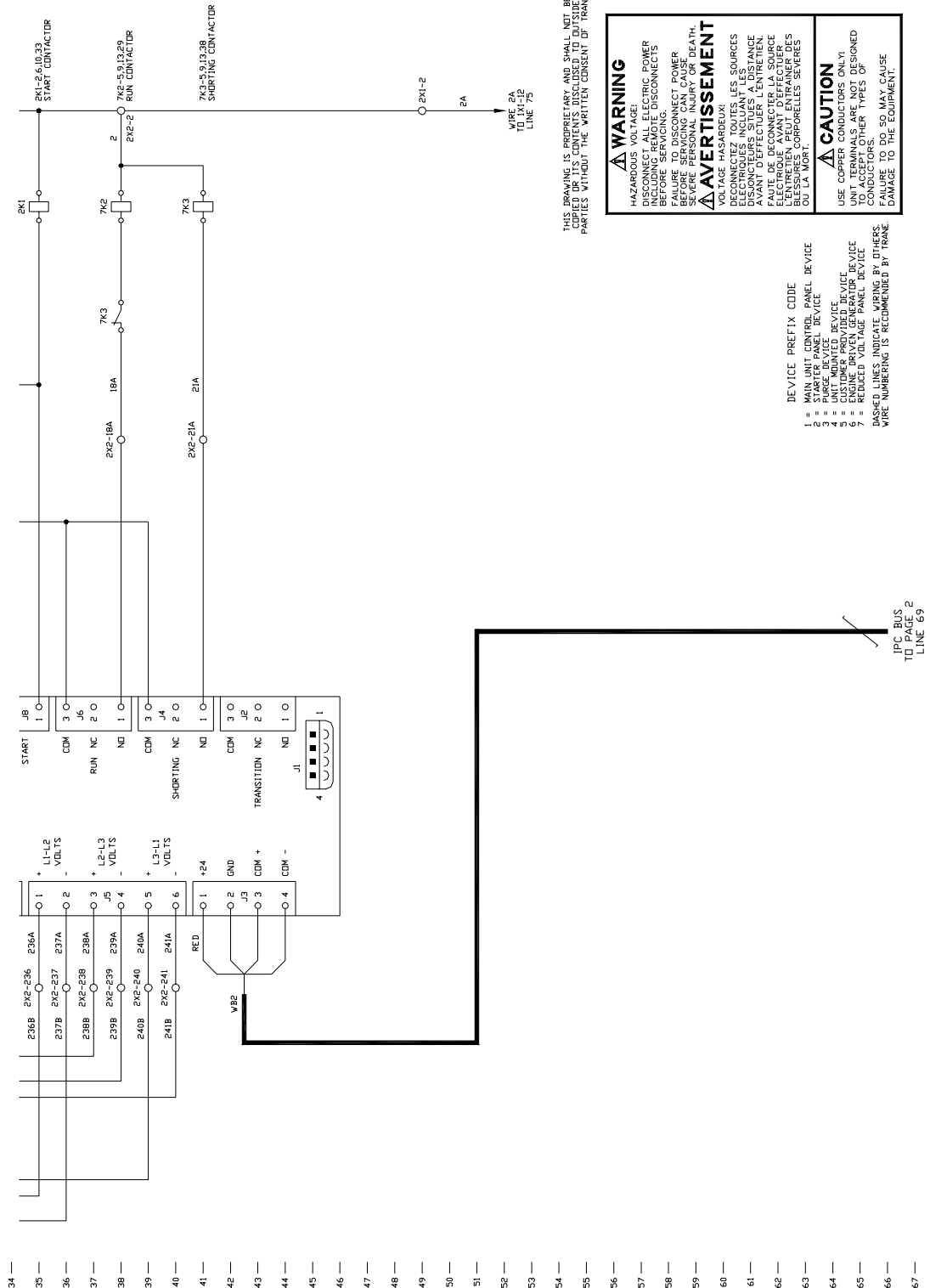

THIS DRAWING IS PROPRIETARY AND SHALL NOT BE REPRODUCED OR TRANSMITTED IN ANY FORM OR BY ANY MEANS WITHOUT THE WRITTEN CONSENT OF TRANE

<p>WARNING</p> <p>HAZARDOUS VOLTAGE: DISCONNECT ALL ELECTRIC POWER BEFORE SERVICING. FAILURE TO DISCONNECT POWER FROM THE EQUIPMENT MAY CAUSE SEVERE PERSONAL INJURY OR DEATH.</p> <p>AVERTISSEMENT</p> <p>VOLTAGE HASARDEUX: DECONNECTEZ TOUTES LES SOURCES ELECTRIQUES INCLUANT LES LIGNES D'ALIMENTATION AVANT D'EFFECTUER L'ENTRETIEN. FAUTE DE DECONNECTER LA SOURCE DE L'ENERGIE PEUT ENTRAINER DES BLESSURES CORPORELLES SEVERES OU LA MORT.</p>	<p>CAUTION</p> <p>USE COPPER CONDUCTORS ONLY! UNIT TERMINALS ARE NOT DESIGNED FOR OTHER TYPES OF CONDUCTORS. FAILURE TO DO SO MAY CAUSE DAMAGE TO THE EQUIPMENT.</p>
---	---

- DEVICE PREFIX CODE
- 1 = STARTER CONTROL PANEL DEVICE
 - 2 = STARTER PANEL DEVICE
 - 3 = PURGE DEVICE
 - 4 = STOP DEVICE
 - 5 = CUSTOMER PROVIDED DEVICE
 - 6 = ENGINE DRIVEN GENERATOR DEVICE
 - 7 = REDUCED VOLTAGE PANEL DEVICE
- DASHED LINES INDICATE WIRING BY OTHERS.
WIRE NUMBERING IS RECOMMENDED BY TRANE.

IPC BUS
TO PAGE 2
LINE 69

2309-7985

Unit mounted primary reactor starter standard 3-lead motor connection with optional GRDF and PFCC, without optional CPTR

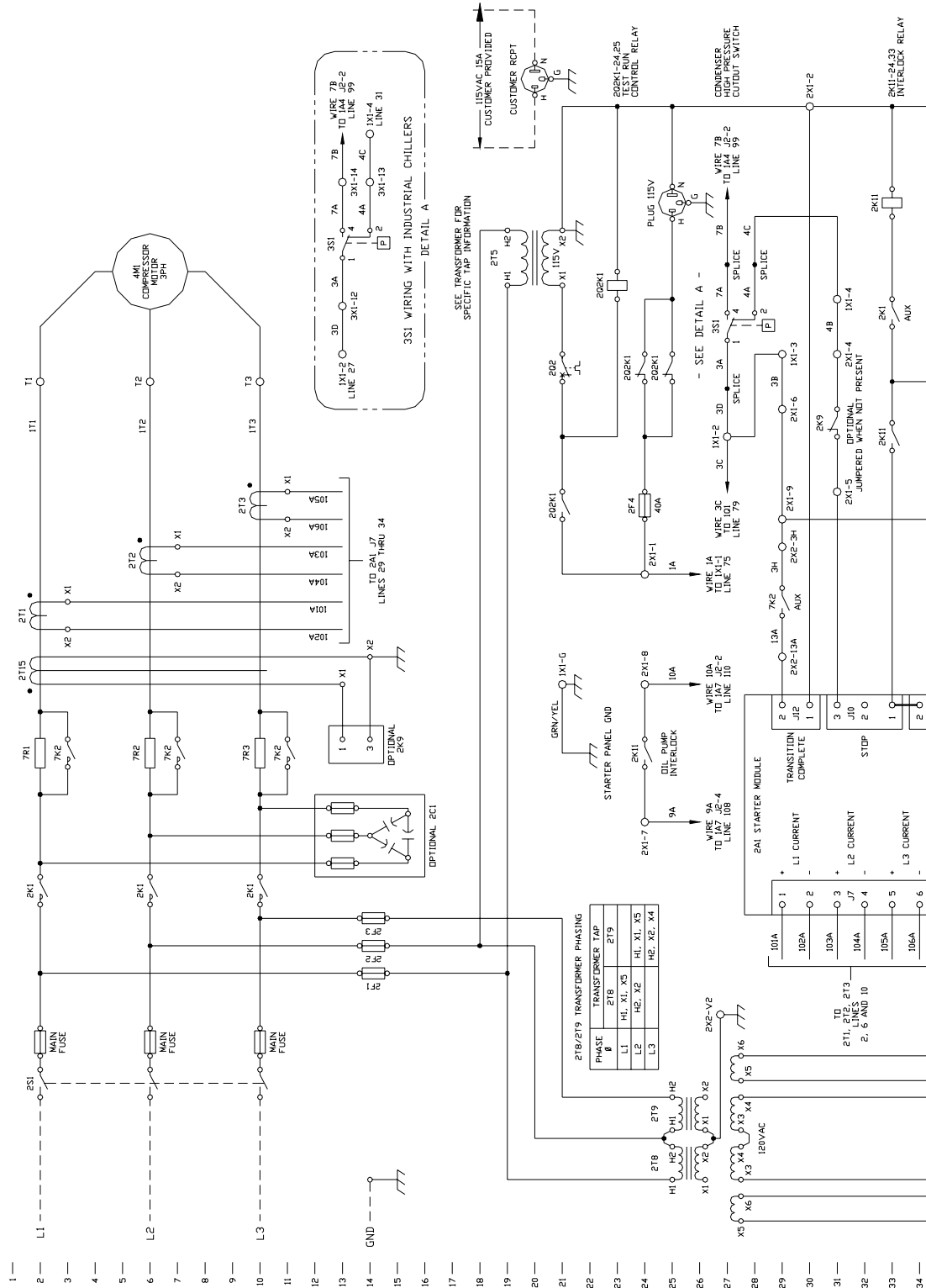

2309-7985 (Con't)

Unit mounted primary reactor starter standard 3-lead motor connection with optional GRDF and PFCC, without optional CPTR

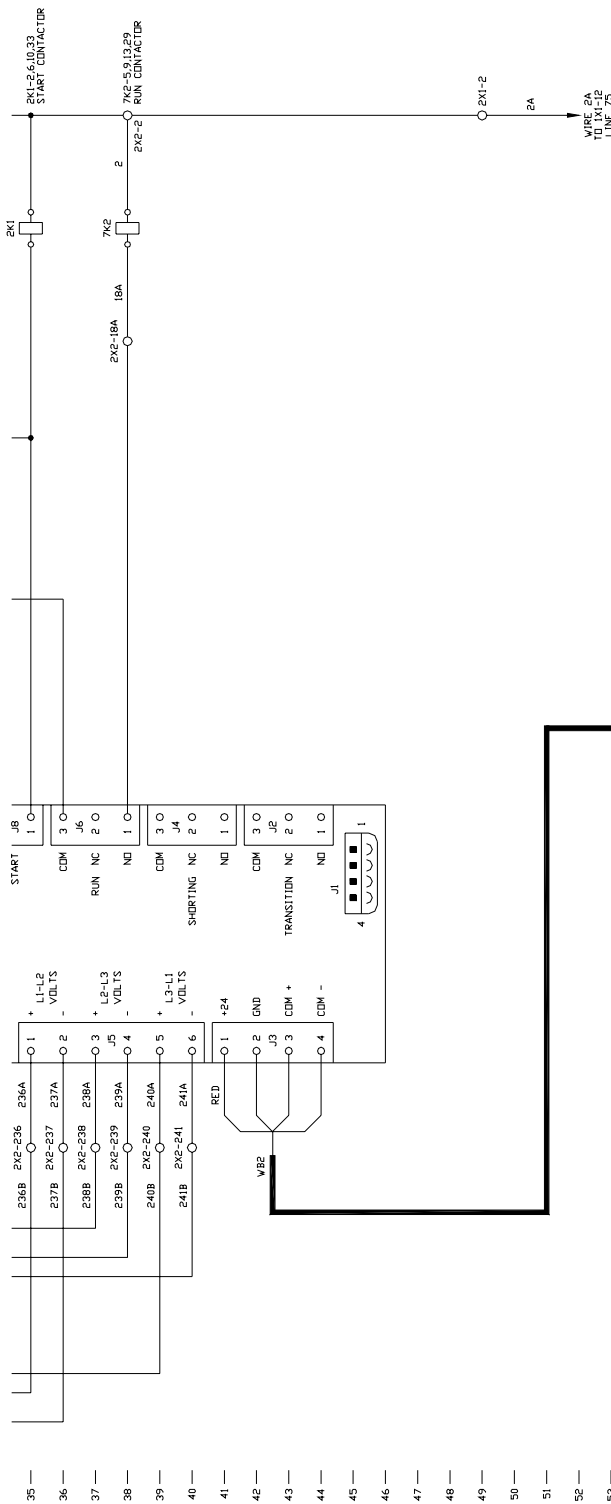

THIS DRAWING IS PROPRIETARY AND SHALL NOT BE REPRODUCED OR COPIED OR ITS CONTENTS DISCLOSED TO OUTSIDE PARTIES WITHOUT THE WRITTEN CONSENT OF TRANE

⚠ WARNING
HAZARDOUS VOLTAGE!
DISCONNECT ALL ELECTRIC POWER BEFORE SERVICING. SEVERE PERSONAL INJURY OR DEATH.

⚠ AVERTISSEMENT
VOLTAGE HASARDEUX!
DÉCONNECTEZ TOUTES LES SOURCES DE TENSION AVANT D'EFFECTUER L'ENTRETIEN. UN VOLTAGE ÉLECTRIQUE AVANT D'EFFECTUER L'ENTRETIEN PEUT ENTRAÎNER DES BLESSURES CORPORELLES SÈVES OU LA MORT.

⚠ CAUTION
USE COPPER CONDUCTORS ONLY!
TO ACCEPT OTHER TYPES OF CONDUCTORS, FAILURE TO DO SO MAY CAUSE DAMAGE TO THE EQUIPMENT.

- DEVICE PREFIX CODE
- 1 = MAIN UNIT CONTROL PANEL DEVICE
 - 2 = STARTER PANEL DEVICE
 - 3 = UNIT MOUNTED DEVICE
 - 4 = CUSTOMER PROVIDED DEVICE
 - 5 = REDUCED VOLTAGE PANEL DEVICE
- DASHED LINES INDICATE WIRING BY OTHERS. WIRE NUMBERING IS RECOMMENDED BY TRANE.

IPC BUS TO PAGE 2
LINE 69

2309-7983

Remote mounted primary reactor starter standard 3-lead motor connection with optional GRDF and PFCC, without optional CPTR

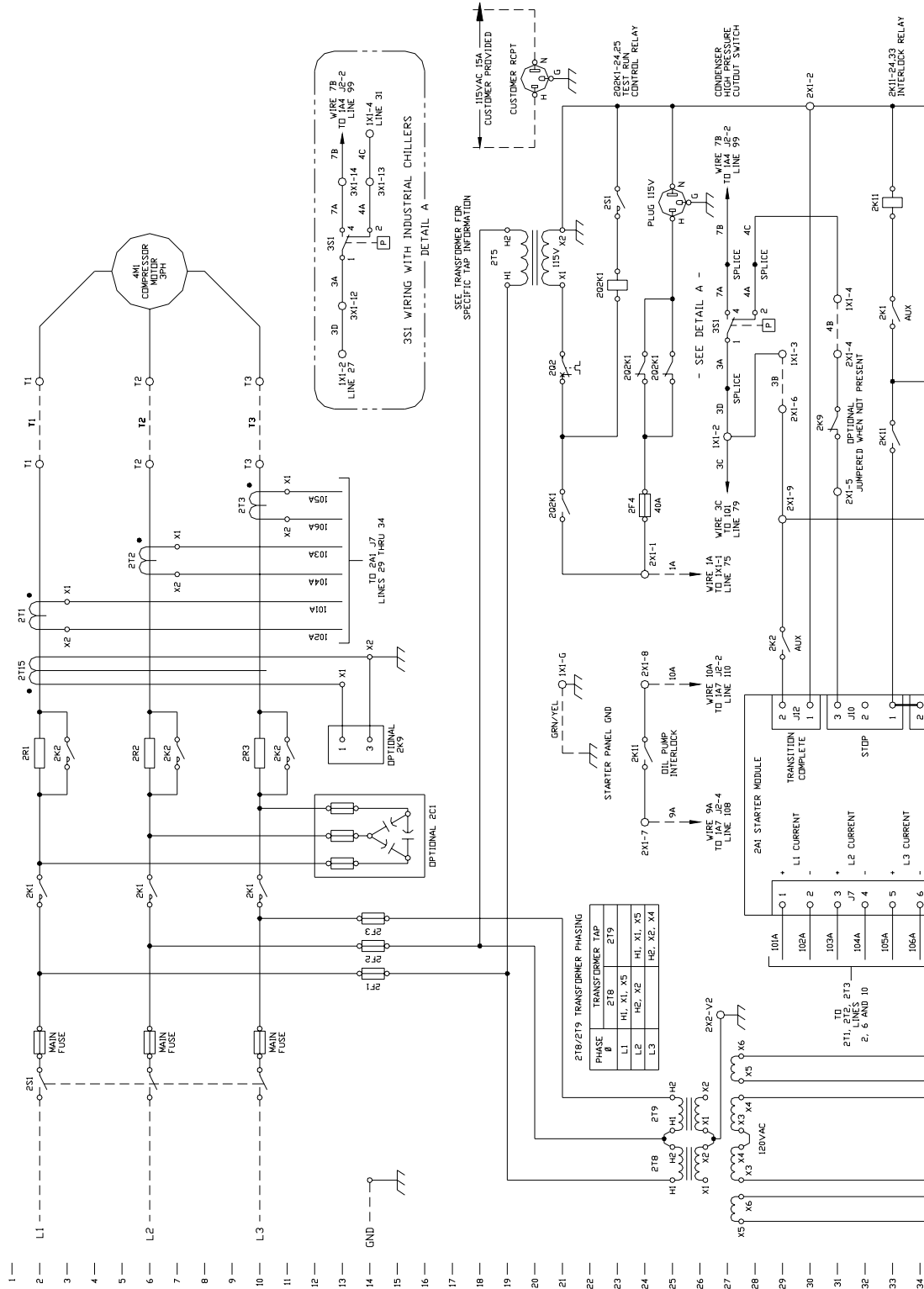

2309-7983 (Con't)

Remote mounted primary reactor starter standard 3-lead motor connection with optional GRDF and PFCC, without optional CPTR

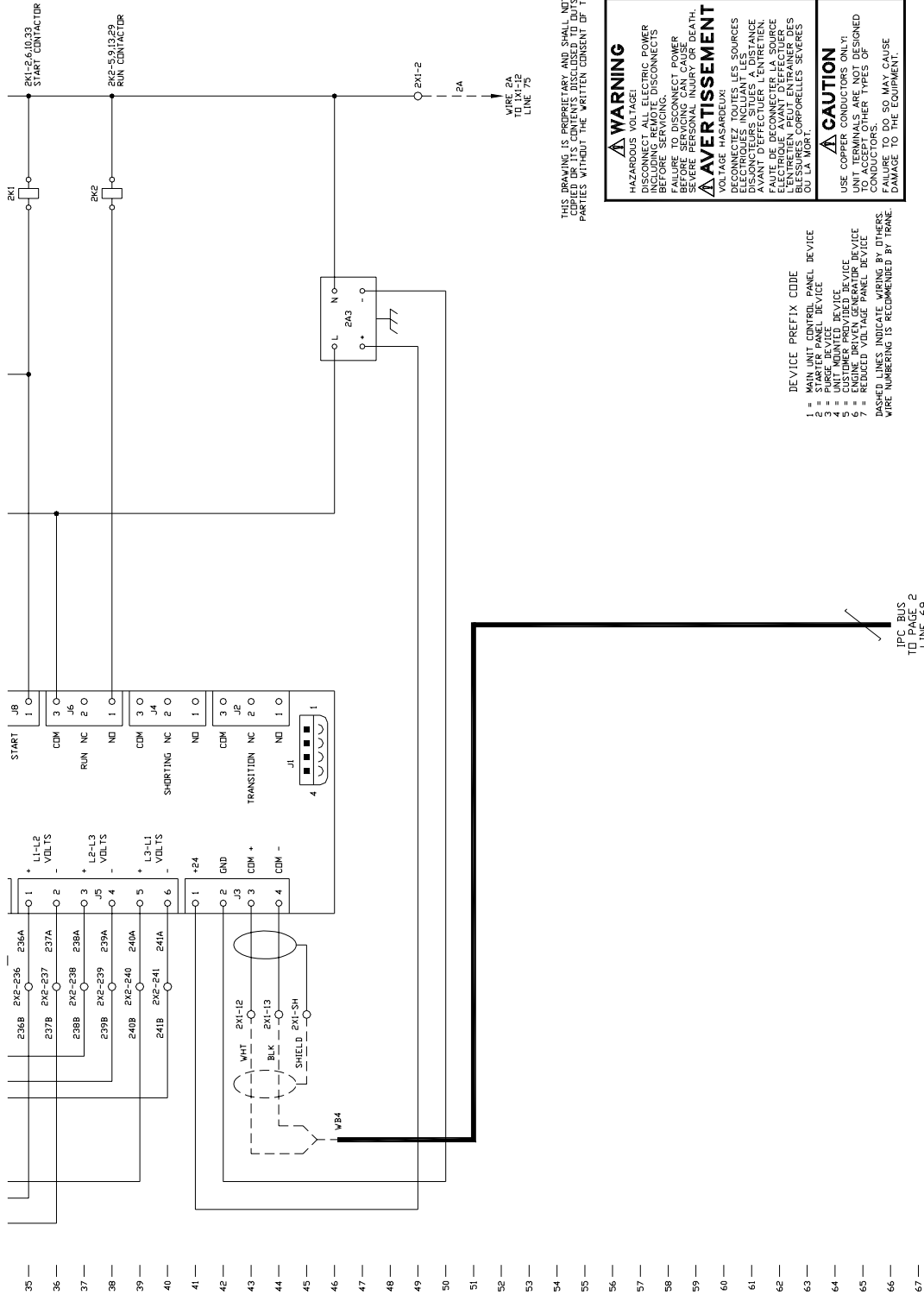

THIS DRAWING IS PROPRIETARY AND SHALL NOT BE REPRODUCED OR TRANSMITTED IN ANY FORM OR BY ANY MEANS, ELECTRONIC OR MECHANICAL, INCLUDING PHOTOCOPYING, RECORDING, OR BY ANY INFORMATION STORAGE AND RETRIEVAL SYSTEM, WITHOUT THE WRITTEN CONSENT OF TRANE.

<p>⚠ WARNING</p> <p>HAZARD: VOLTAGE. DISCONNECT ALL ELECTRIC POWER INCLUDING REMOTE DISCONNECTS BEFORE SERVICING. THE MAIN DISCONNECT FUSE OR CIRCUIT BREAKER CAN CAUSE SEVERE PERSONAL INJURY OR DEATH.</p> <p>⚠ AVERTISSEMENT</p> <p>VOLTAGE HAZARDEUX: DECONNECTEZ TOUTES LES SOURCES DE COURANT ÉLECTRIQUE Y COMPRIS LES DISJONCTEURS À DISTANCE AVANT D'EFFECTUER L'ENTRETIEN. LE DISJONCTEUR À DISTANCE PEUT ENTRAINER DES BLESSURES GRAVES OU LA MORT.</p>	<p>⚠ CAUTION</p> <p>USE COPPER CONDUCTORS ONLY. WIRE TERMINALS ARE NOT DESIGNED TO ACCEPT OTHER TYPES OF CONDUCTORS. FAILURE TO DO SO MAY CAUSE DAMAGE TO THE EQUIPMENT.</p>
---	---

- DEVICE PREFIX CODE
- 1 = MAIN UNIT CONTROL PANEL DEVICE
 - 2 = STARTER PANEL DEVICE
 - 3 = UNIT MOUNTED DEVICE
 - 4 = CUSTOMER PROVIDED DEVICE
 - 5 = REDUCED VOLTAGE PANEL DEVICE
 - 6 = REDUCED VOLTAGE PANEL DEVICE
 - 7 = REDUCED VOLTAGE PANEL DEVICE
- DASHED LINES INDICATE WIRING BY OTHERS. WIRE NUMBERING IS RECOMMENDED BY TRANE.

IPC BUS TO PAGE 2 LINE 69

2309-7998

Customer supplied wye-delta starter standard chiller without optional CPTR

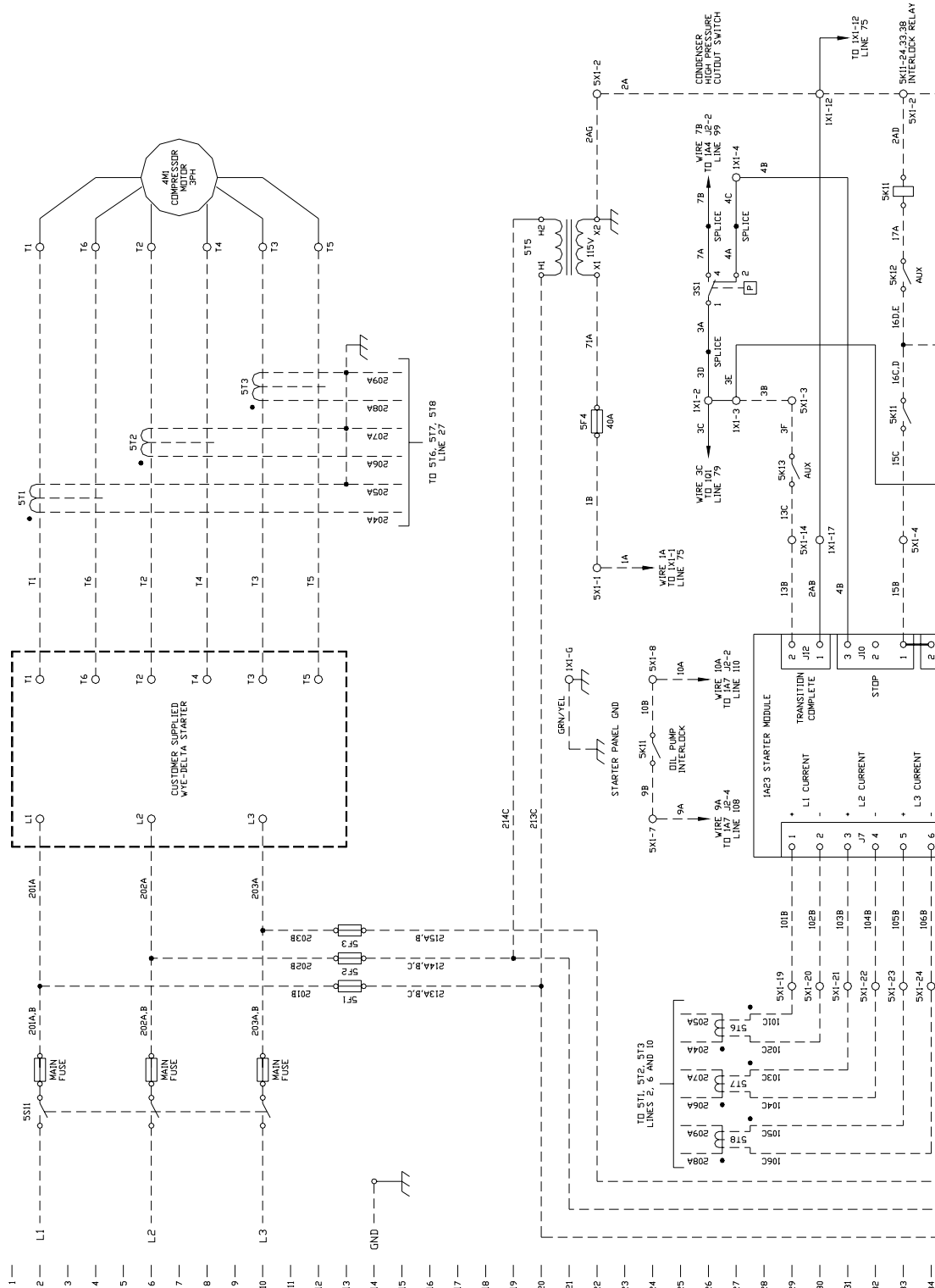

2309-8012

Customer supplied auto-transformer or primary reactor starter standard 3-lead motor connection without optional CPTR

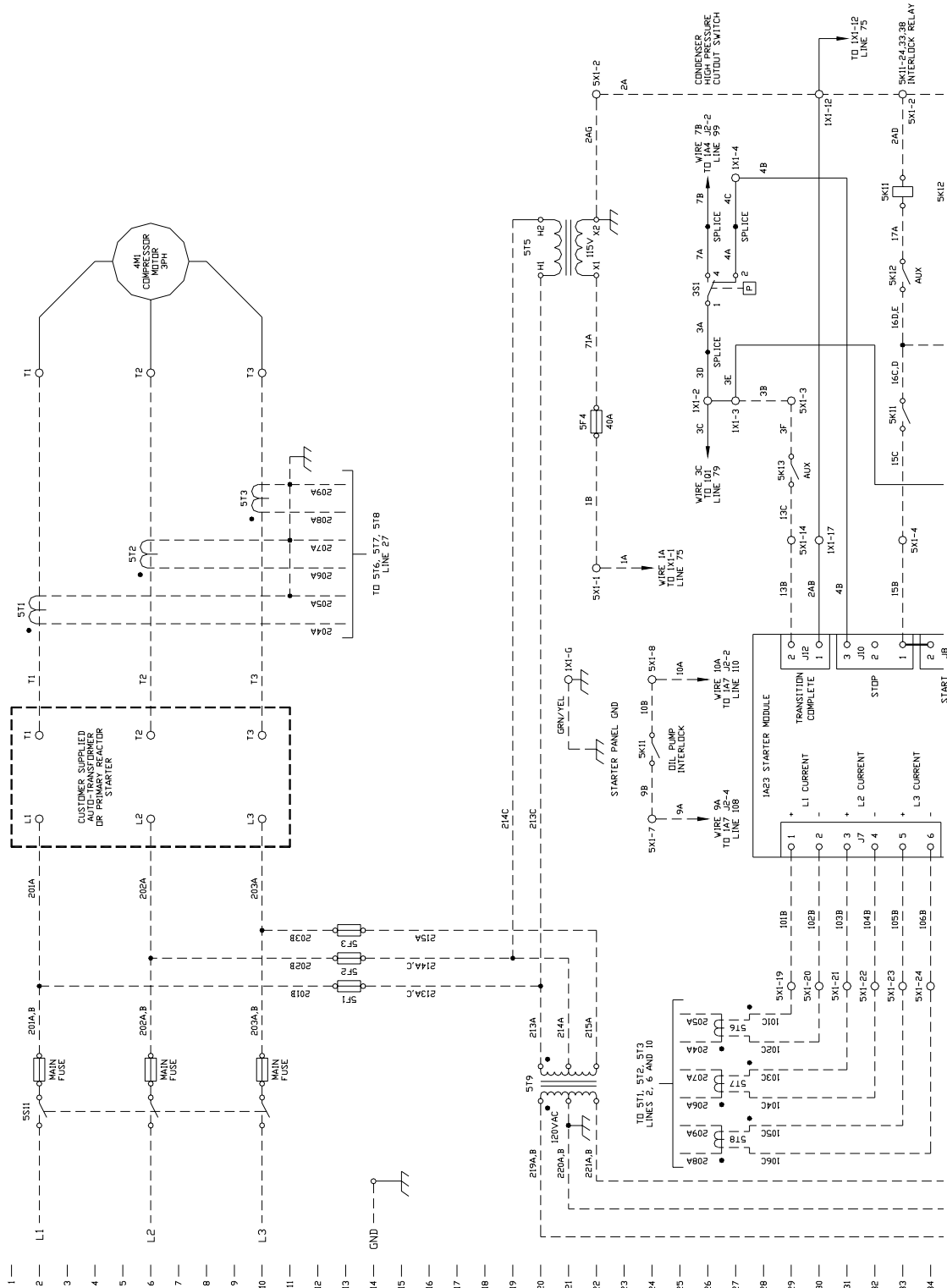

2309-8012 (Con't)

Customer supplied auto-transformer or primary reactor starter standard 3-lead motor connection without optional CPTR

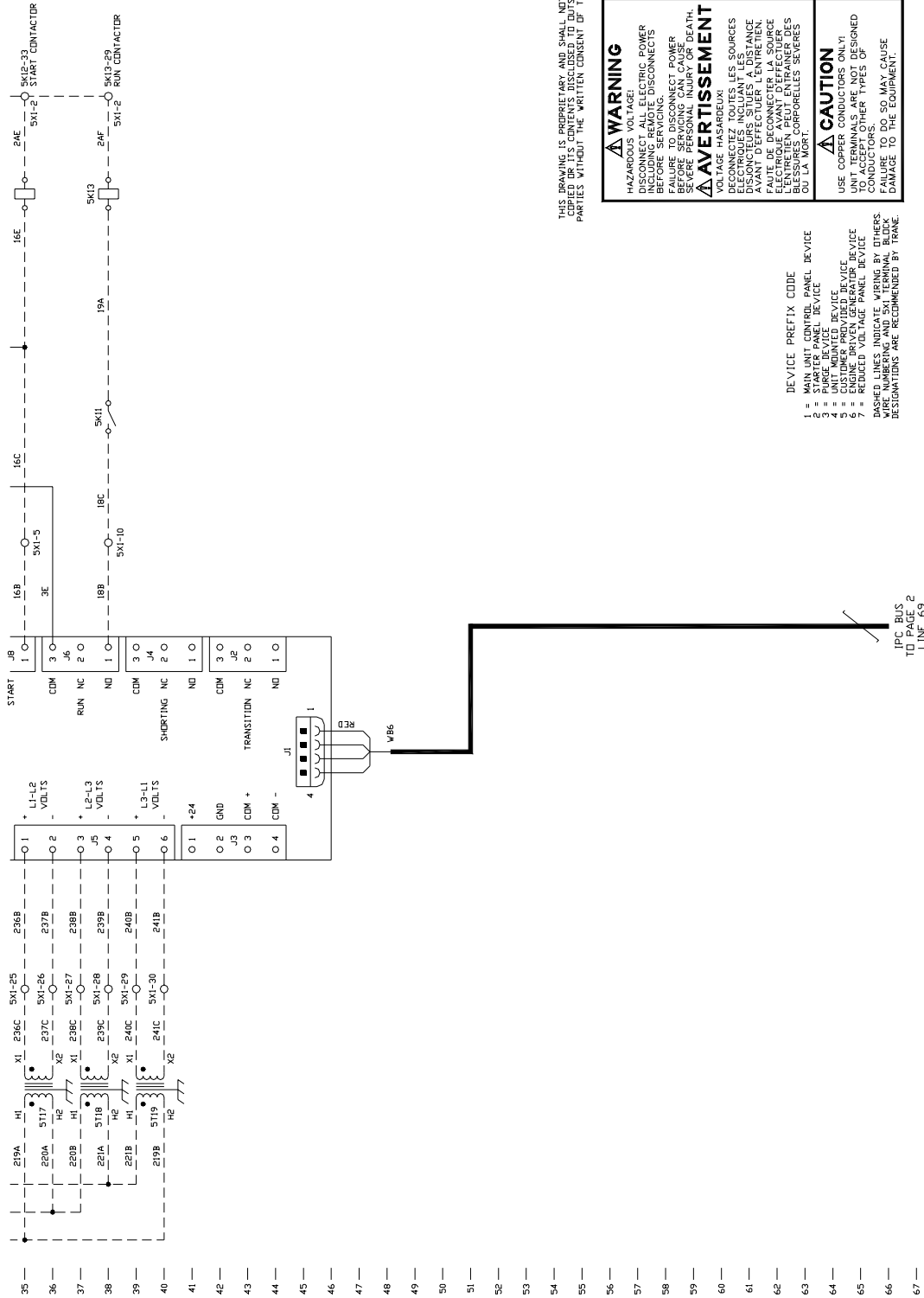

THIS DRAWING IS PROPRIETARY AND SHALL NOT BE COPIED OR ITS CONTENTS DISCLOSED TO OUTSIDE PARTIES WITHOUT THE WRITTEN CONSENT OF TRANE.

⚠ WARNING
 HAZARDOUS VOLTAGE!
 DISCONNECT ALL ELECTRIC POWER INCLUDING REMOTE DISCONNECTS BEFORE SERVICING. FAILURE TO DISCONNECT POWER BEFORE SERVICING CAN CAUSE SEVERE PERSONAL INJURY OR DEATH.

⚠ AVERTISSEMENT
 VOLTAGE HASARDEUX!
 DÉCONNECTEZ TOUS LES SOURCES D'ÉLECTRICITÉ Y COMPRIS LES DISCONNECTEURS SITUÉS À DISTANCE AVANT D'EFFECTUER L'ENTRETIEN. L'ÉLECTRIQUE AVANT D'EFFECTUER L'ENTRETIEN PEUT ENTRAINER DES BLESSURES GRAVES OU LA MORT.

- CAUTION**
 USE COPPER CONDUCTORS ONLY TO ACCEPT OTHER TYPES OF CONDUCTORS.
 DASHED LINES INDICATE WIRING BY OTHERS. WIRE NUMBERING AND 5X1 TERMINAL BLOCK DESIGNATIONS ARE RECOMMENDED BY TRANE.
- DEVICE PREFIX CODE**
- 1 = MAIN UNIT CONTROL PANEL DEVICE
 - 2 = STARTER PANEL DEVICE
 - 3 = UNIT MOUNTED DEVICE
 - 4 = CUSTOMER PROVIDED DEVICE
 - 5 = REDUCED VOLTAGE PANEL DEVICE
 - 7 = REDUCED VOLTAGE PANEL DEVICE

IPC BUS TO PAGE 2 LINE 69

2309-8022

Customer supplied across the line starter standard 3-lead motor connection without optional CPTR

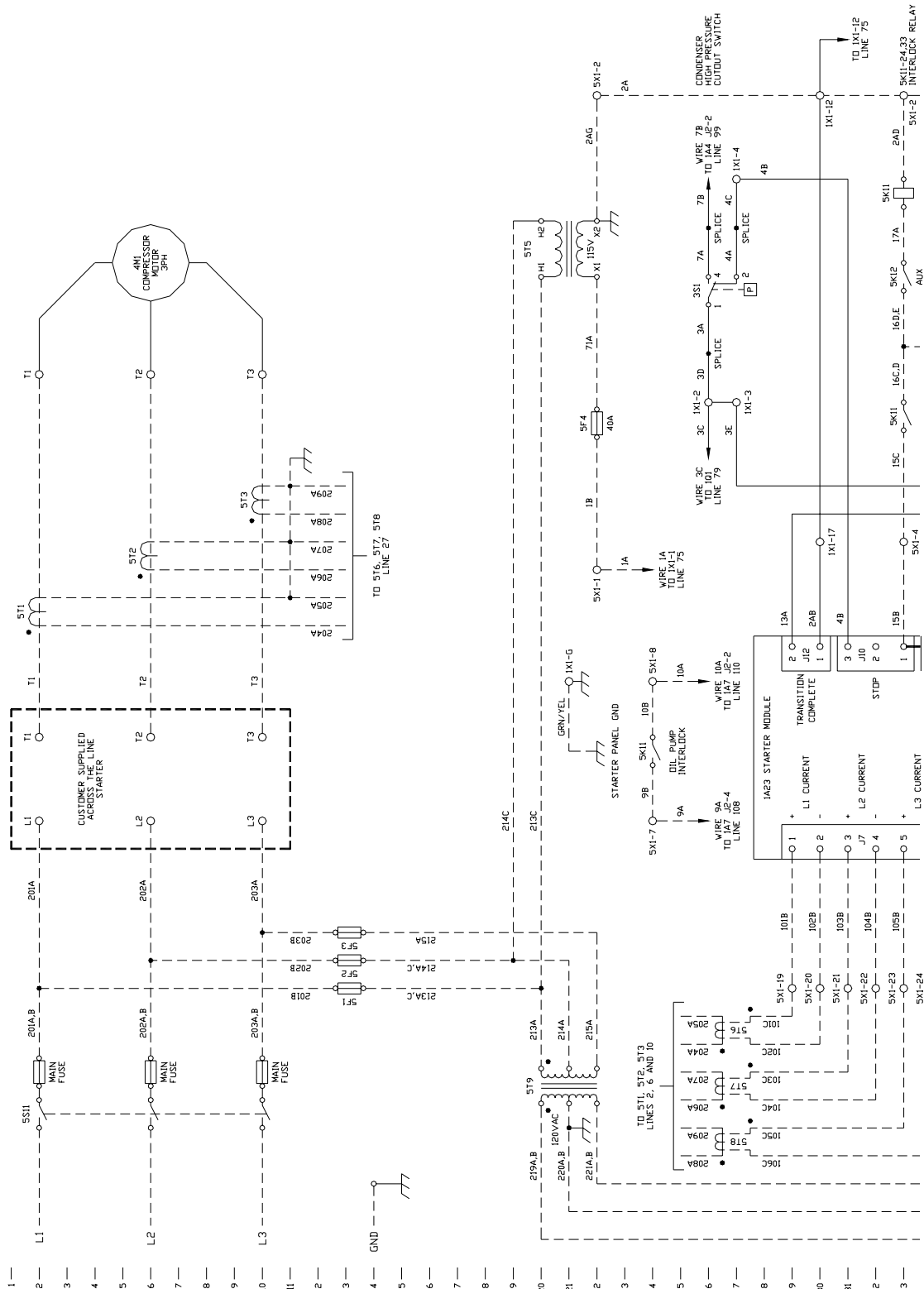

2309-8022 (Con't)

Customer supplied across the line starter standard 3-lead motor connection without optional CPTR

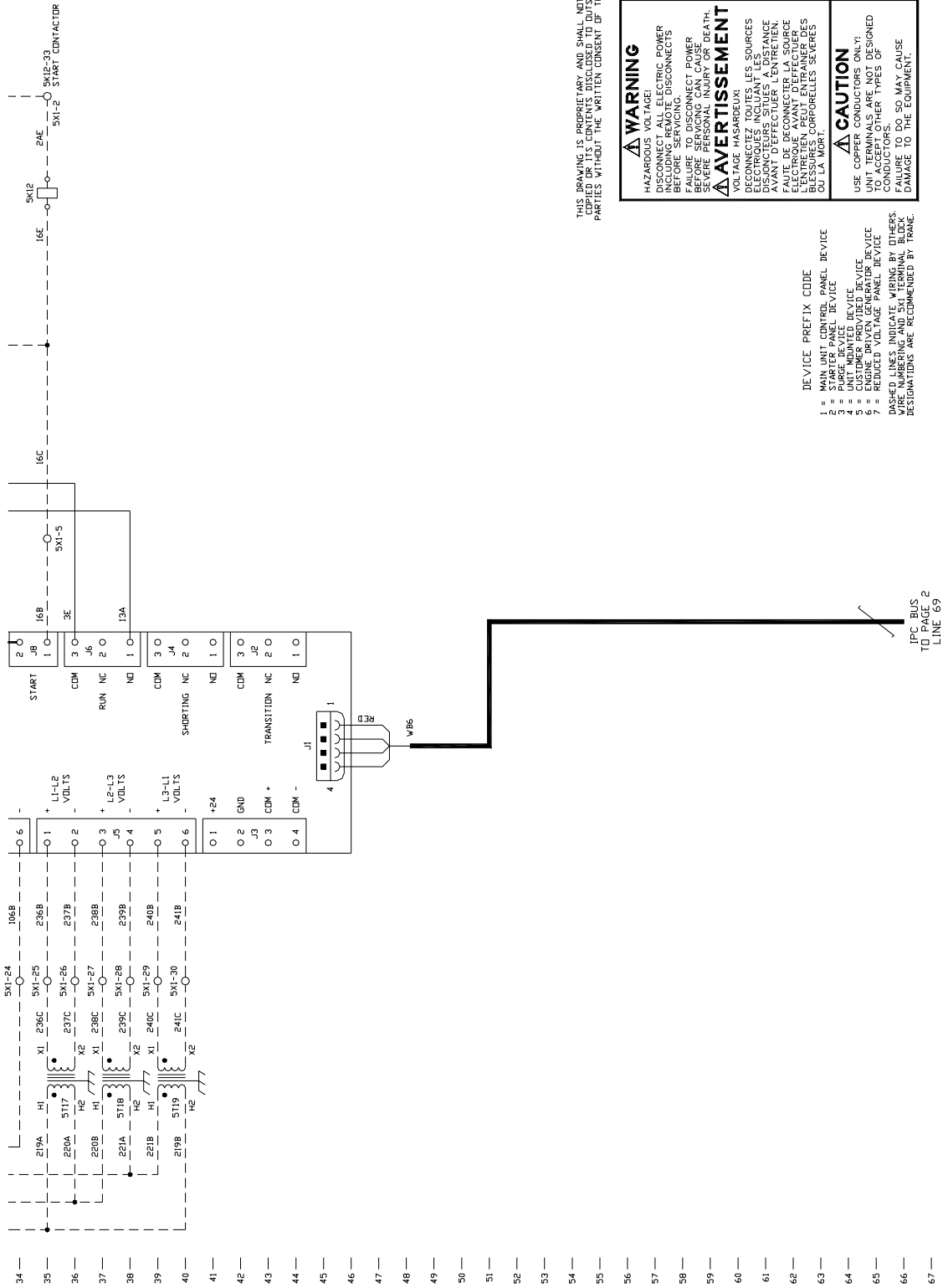

2309-8002

Customer supplied solid state starter standard chiller without optional CPTR

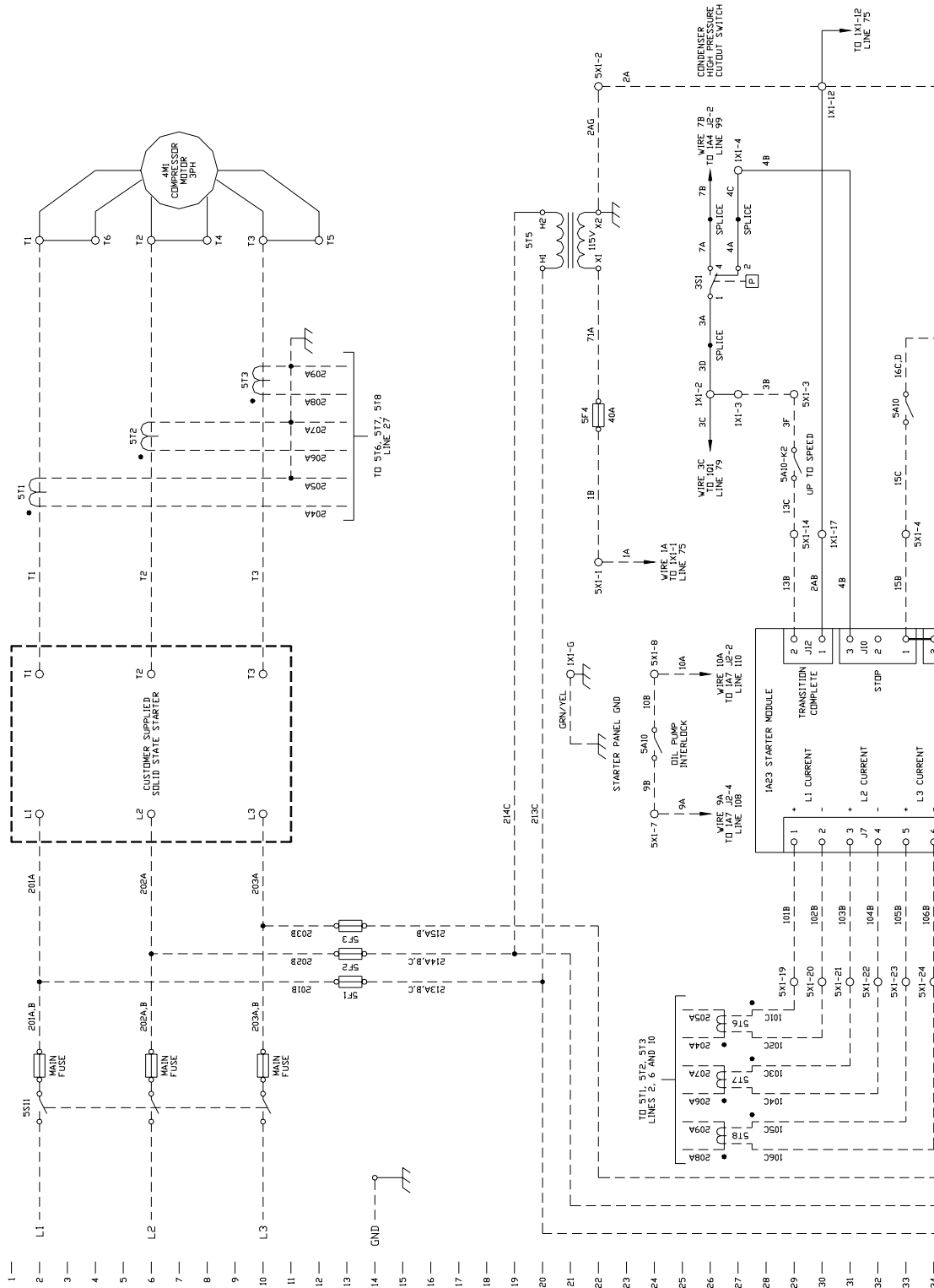

2309-8041
Factory installed standard, NEMA 4 or industrial earthwise purge

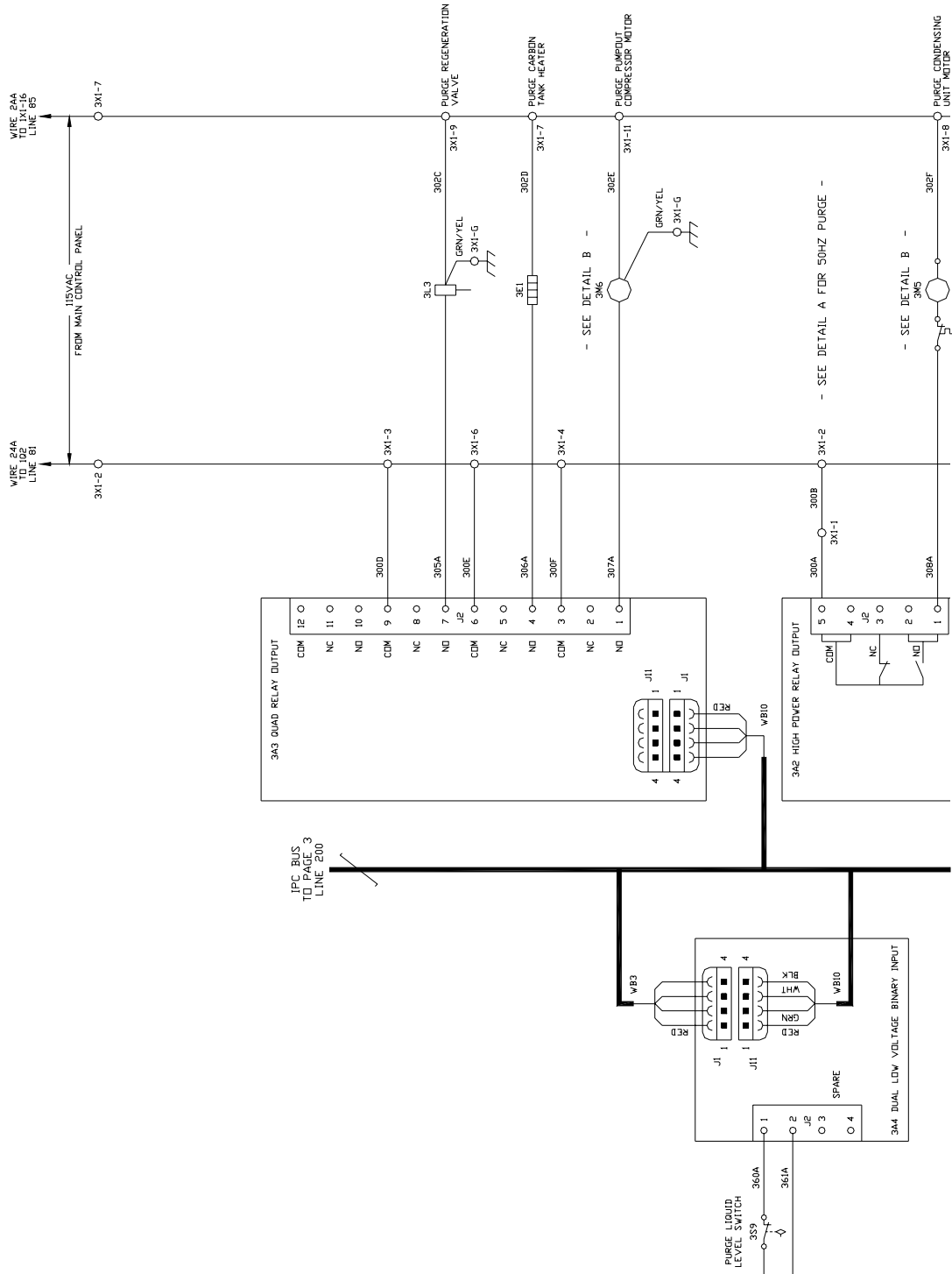

- 202 —
- 203 —
- 204 —
- 205 —
- 206 —
- 207 —
- 208 —
- 209 —
- 210 —
- 211 —
- 212 —
- 213 —
- 214 —
- 215 —
- 216 —
- 217 —
- 218 —
- 219 —
- 220 —
- 221 —
- 222 —
- 223 —
- 224 —
- 225 —
- 226 —
- 227 —
- 228 —
- 229 —
- 230 —
- 231 —
- 232 —
- 233 —
- 234 —

2309-8039 (Con't) System controls with optional HGBP or FRCL

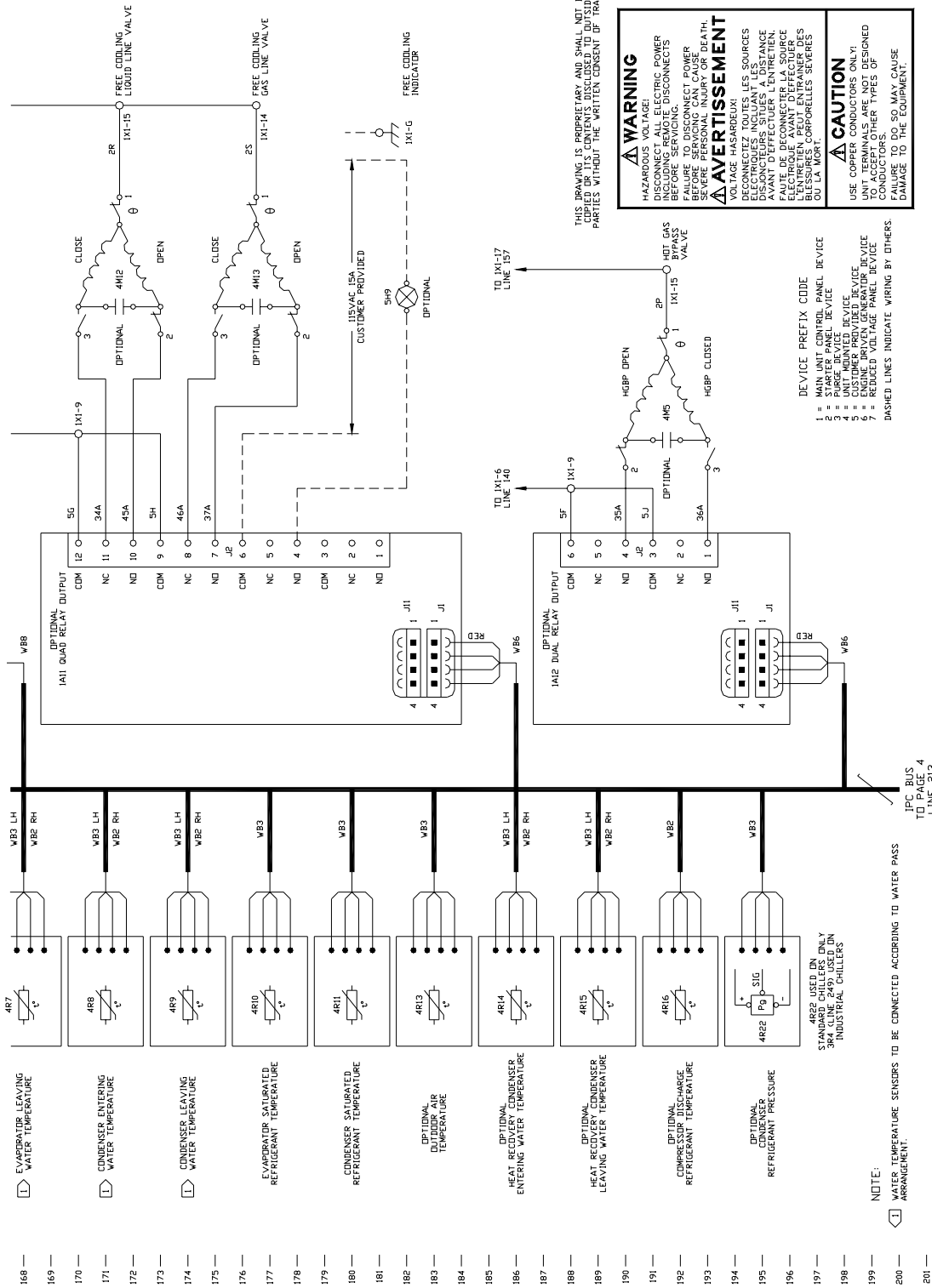

2309-8043 Optional controls

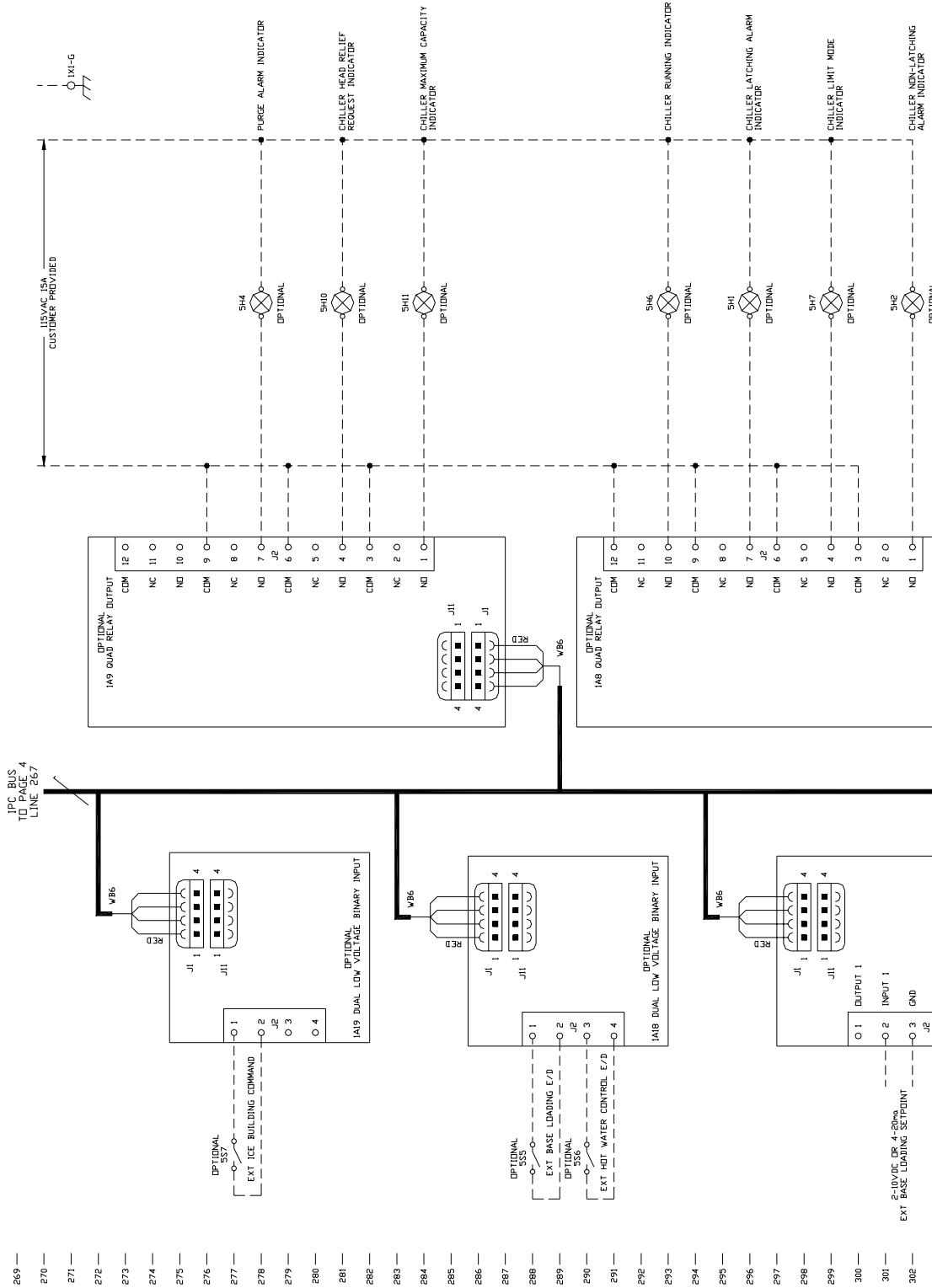

2309-8043 (Con't) Optional controls

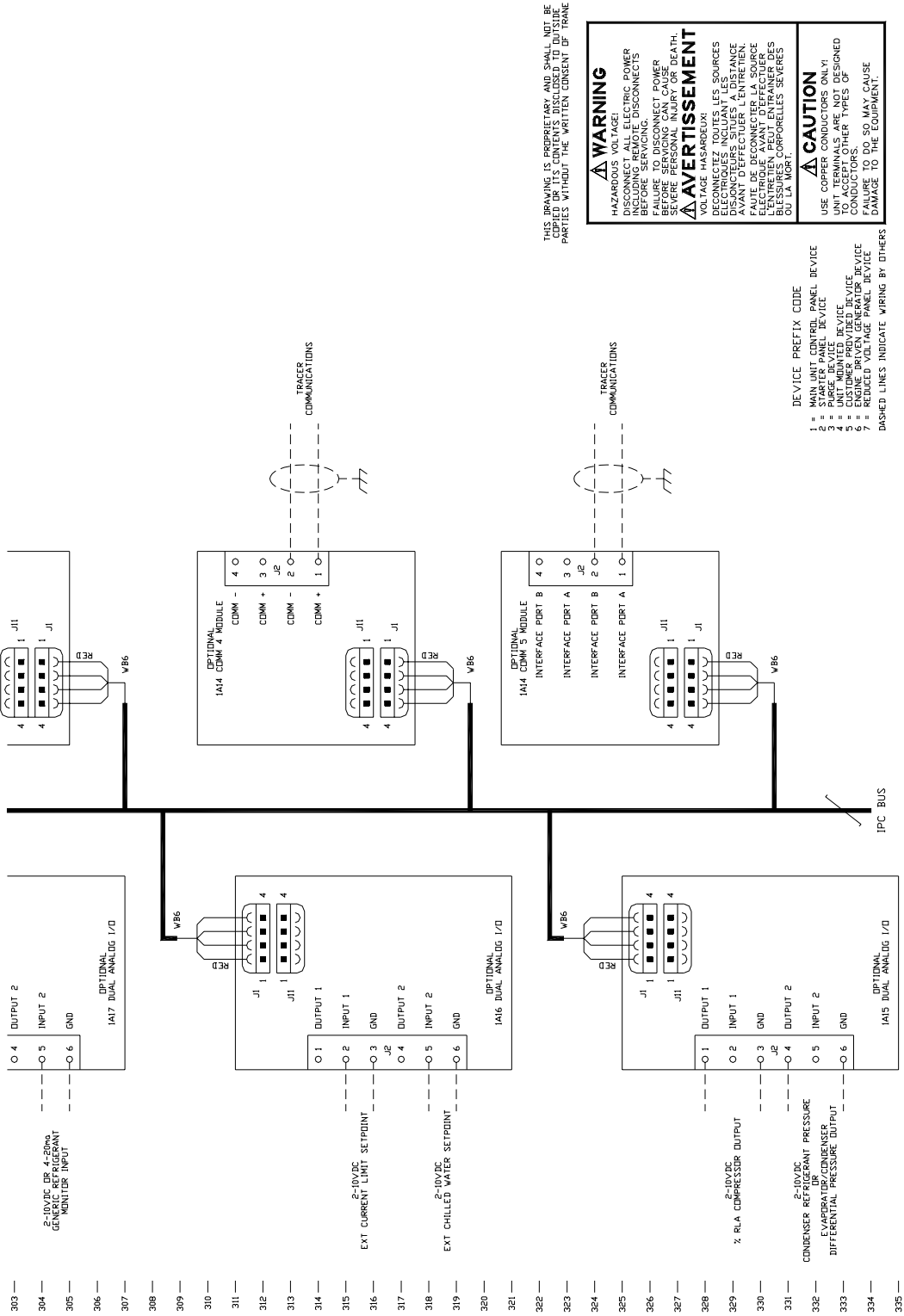

THIS DRAWING IS PROPRIETARY AND SHALL NOT BE COPIED OR ITS CONTENTS DISCLOSED TO OUTSIDE PARTIES WITHOUT THE WRITTEN CONSENT OF TRANE.

⚠ WARNING
HAZARDOUS VOLTAGE!
DISCONNECT ALL ELECTRIC POWER INCLUDING REMOTE DISCONNECTS BEFORE SERVICING. DISCONNECT POWER BEFORE SERVICING CAN CAUSE SEVERE PERSONAL INJURY OR DEATH.

⚠ AVERTISSEMENT
VOLTAGE HASARDEUX!
DECONNECTEZ TOUTES LES SOURCES D'ÉLECTRICITÉ Y COMPRIS LES DISJONCTEURS SÉPARÉS À DISTANCE AVANT D'EFFECTUER L'ENTRETIEN. DÉCONNECTER LE POUVOIR ÉLECTRIQUE AVANT D'EFFECTUER LE TRAVAIL PEUT CAUSER DES BLESSURES PERSONNELLES SÈRES OU LA MORT.

⚠ CAUTION
USE COPPER CONDUCTORS ONLY! TO ACCEPT OTHER TYPES OF CONDUCTORS, REFER TO THE DESIGNER'S SPECIFICATIONS. FAILURE TO FOLLOW THESE INSTRUCTIONS MAY CAUSE DAMAGE TO THE EQUIPMENT.

- DEVICE PREFIX CODE
- 1 = MAIN UNIT CONTROL PANEL DEVICE
 - 2 = MAIN UNIT CONTROL PANEL DEVICE
 - 3 = PURGE DEVICE
 - 4 = UNIT-MOUNTED DEVICE
 - 5 = UNIT-MOUNTED DEVICE
 - 6 = ENGINE-DRIVEN GENERATOR DEVICE
 - 7 = REDUCED VOLTAGE PANEL DEVICE
- DASHED LINES INDICATE WIRING BY OTHERS

2309-2178)

Main unit control panel used with all low and medium voltage starters

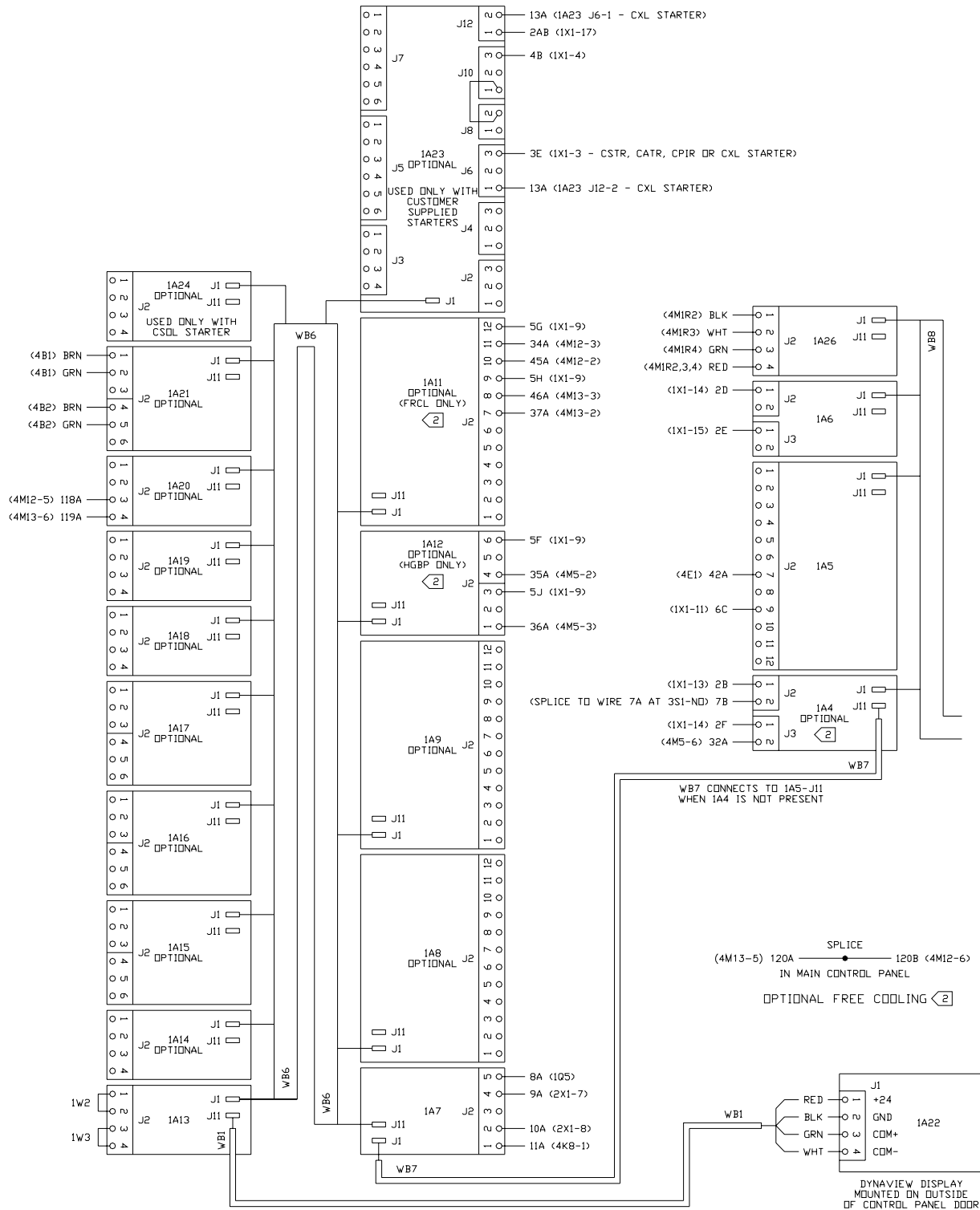

2309-2169

Trane supplied Wye-delta or solid state starter

WARNING
HAZARDOUS VOLTAGE
DISCONNECT ALL ELECTRIC POWER INCLUDING REMOTE DISCONNECTS BEFORE SERVICING.
FAILURE TO DISCONNECT POWER BEFORE SERVICING CAN CAUSE SEVERE PERSONAL INJURY OR DEATH.

AVERTISSEMENT
VOLTAGE HASARDEUX
DECONNECTEZ TOUTES LES SOURCES ELECTRIQUES INCLUANT LES DISJONCTEURS SITES A DISTANCE AVANT D'EXECUTER L'ENTRETIEN.
FAUTE DE DECONNECTER LA SOURCE ELECTRIQUE AVANT D'EXECUTER L'ENTRETIEN PEUT ENTRAINER DES BLESSURES CORPORELLES SEVERES OU LA MORT.

CAUTION
USE COPPER CONDUCTORS ONLY!
UNIT TERMINALS ARE NOT DESIGNED TO ACCEPT OTHER TYPES OF CONDUCTORS.
FAILURE TO DO SO MAY CAUSE DAMAGE TO THE EQUIPMENT.

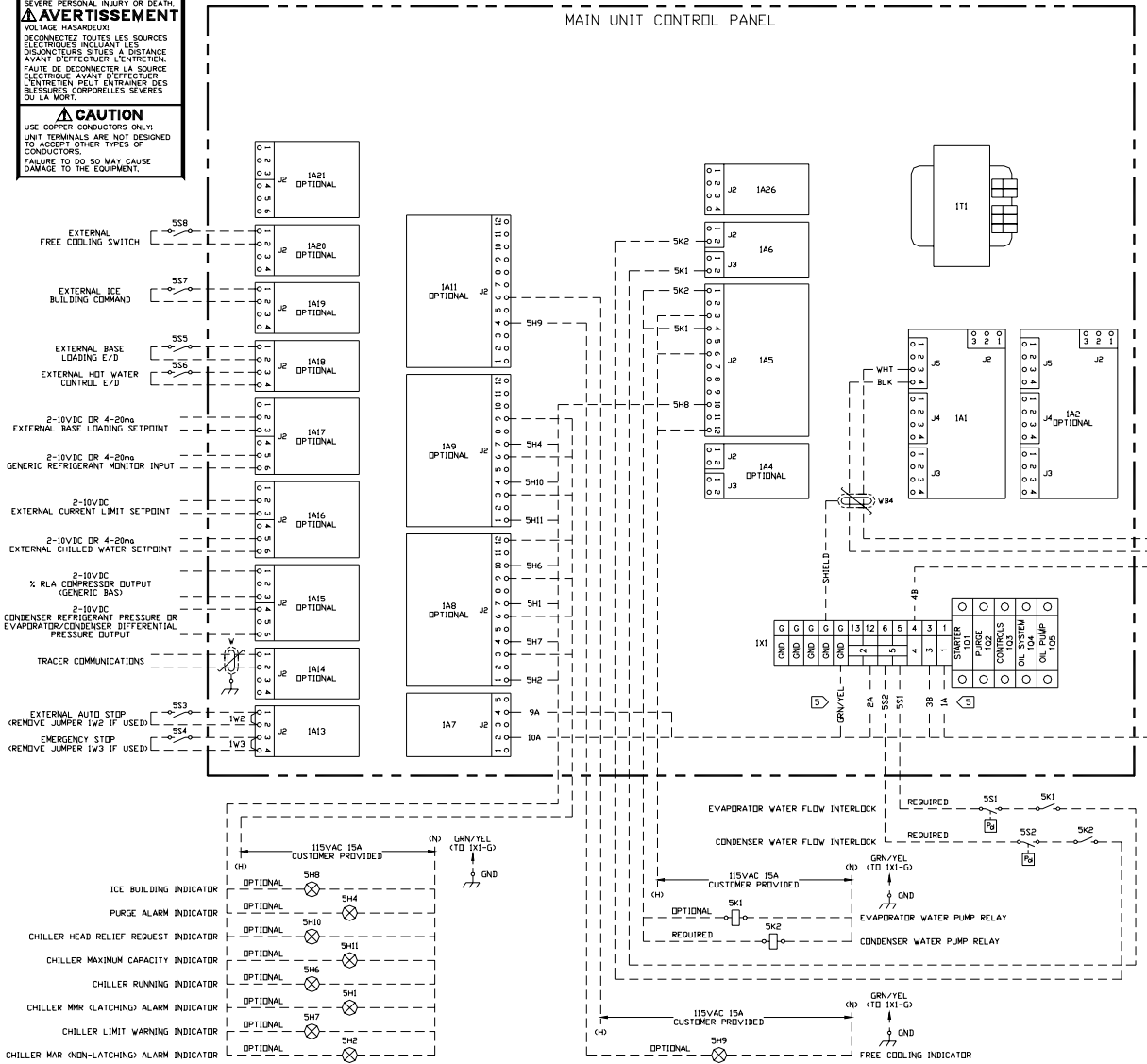

2309-2169 (Con't) Trane supplied Wye-delta or solid state starter

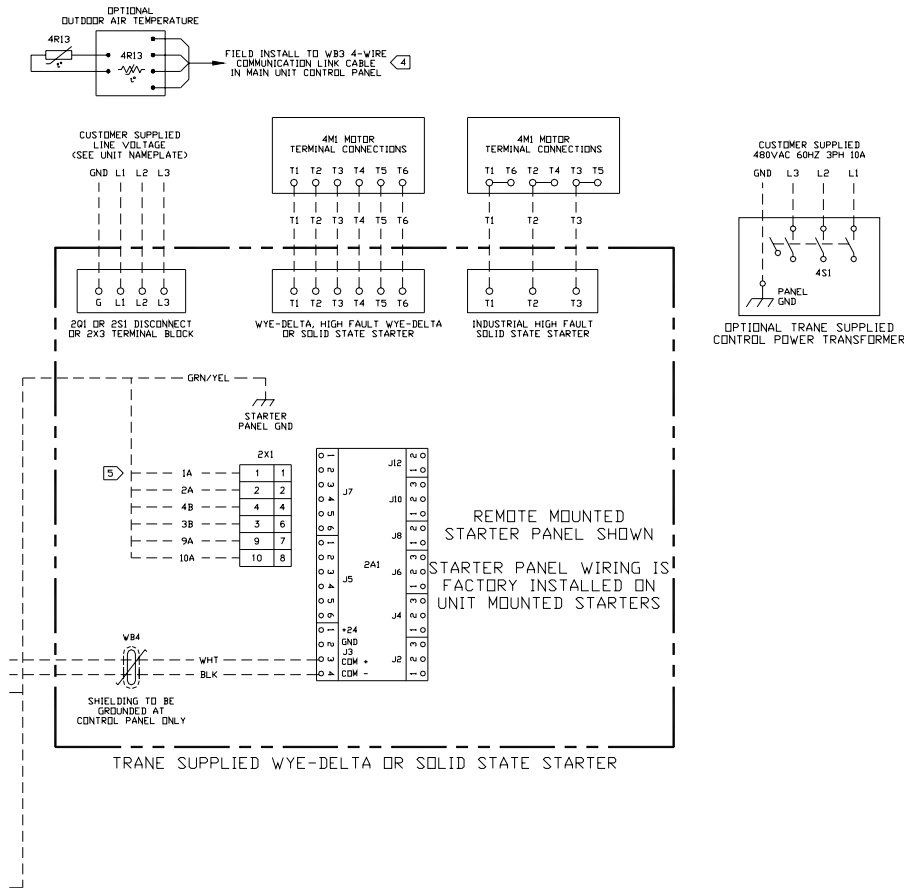

FIELD WIRING CIRCUIT SELECTION INFORMATION

WIRE NO OR DEVICE	CIRCUIT INFORMATION
SUPPLY AND MOTOR LEADS	SEE NAMEPLATE; MINIMUM CIRCUIT AMPACITY
1A*, 2A* AND GRN/YEL	4000VA AT 115 VAC, 8 AWG MAX WIRE SIZE
9A* AND 10A*	PUMP MOTOR; 1PH 3/4 HP, 11.7 FULL LOAD AMPS AT 115 VAC 14 AWG MAX WIRE SIZE
WB4	TWISTED, SHIELDED PAIR, 30 VDC, MAX LENGTH 1500 FT (BELDON TYPE 8760 RECOMMENDED)
5S1*, 5S2*, 3B* AND 4B*	CIRCUIT PROTECTED AT 20A, 115 VAC 1PH, 10 AWG MAX WIRE SIZE
5S3 THRU 5S8	24 VDC, 12mA RESISTIVE LOAD, 14 AWG MAX WIRE SIZE
ALL REMAINING CH530 LL10 TERMINALS	CONTACT RATING; 2.88A INDUCTIVE, 1/3 HP, 0.25KW AT 115 VAC 14 AWG MAX WIRE SIZE

* TAPPED CONTROL CONDUCTORS

NOTES:

- DASHED LINES INDICATE FIELD WIRING BY OTHERS. WIRE NUMBERS SHOWN ARE RECOMMENDED BY TRANE. CHECK SALES ORDER TO DETERMINE WHICH OPTIONS ARE PRESENT ON THE UNIT.
- DO NOT ROUTE LOW VOLTAGE (30V) WITH CONTROL VOLTAGE (115V) AND DO NOT POWER UNIT UNTIL CHECK-OUT AND START-UP PROCEDURES HAVE BEEN COMPLETED.
- EVAPORATOR AND CONDENSER WATER FLOW SWITCHES ARE REQUIRED AND MUST CONTAIN SPDT CONTACTS. THE SEPARATE FLOW SWITCHES ARE TO BE RUN IN SERIES WITH SEPARATE AUX CONTACTS FOR THE EVAPORATOR AND CONDENSER PUMPS. THEY MUST BE INSTALLED AND WIRED TO THE TRANE MAIN UNIT CONTROL PANEL BY THE INSTALLING CONTRACTOR. THE PURCHASE OF FLOW SWITCHES FROM TRANE IS OPTIONAL.
- OPTIONAL 4R13 OUTDOOR AIR TEMPERATURE SENSOR IS SHIPPED WITH THE UNIT FOR FIELD INSTALLATION. REFER TO THE UNIT INSTALLATION LITERATURE FOR INSTALLATION OPTIONS AT THE JOB SITE.
- WHEN CONTROL POWER TRANSFORMER (CP1R OPTION) IS PRESENT, WIRE 1A IS NOT REQUIRED. WIRE 2A CONNECTS TO 1X1-13 AND GRN/YEL STARTER PANEL GROUND WIRE IS CONNECTED ONE TERMINAL TO THE LEFT FROM WHERE IT IS CURRENTLY SHOWN ON 1X1.

2309-2171

Trane supplied auto-transformer, primary reactor or across the line starter

⚠ WARNING
 HAZARDOUS VOLTAGE
 DISCONNECT ALL ELECTRIC POWER INCLUDING REMOTE DISCONNECTS BEFORE SERVICING.
 FAILURE TO DISCONNECT POWER BEFORE SERVICING CAN CAUSE SEVERE PERSONAL INJURY OR DEATH.

⚠ AVERTISSEMENT
 VOLTAGE HAZARDEUX!
 DECONNECTEZ TOUTES LES SOURCES ELECTRIQUES INCLUANT LES DISCONNECTEURS SITES A DISTANCE AVANT D'EXECUTER L'ENTRETIEN.
 FAUTE DE DECONNECTER LA SOURCE ELECTRIQUE AVANT D'EXECUTER L'ENTRETIEN PEUT ENTRAINER DES BLESSURES CORPORELLES SEVERES OU LA MORT.

⚠ CAUTION
 USE COPPER CONDUCTORS ONLY!
 UNIT TERMINALS ARE NOT DESIGNED TO ACCEPT OTHER TYPES OF CONDUCTORS.
 FAILURE TO DO SO MAY CAUSE DAMAGE TO THE EQUIPMENT.

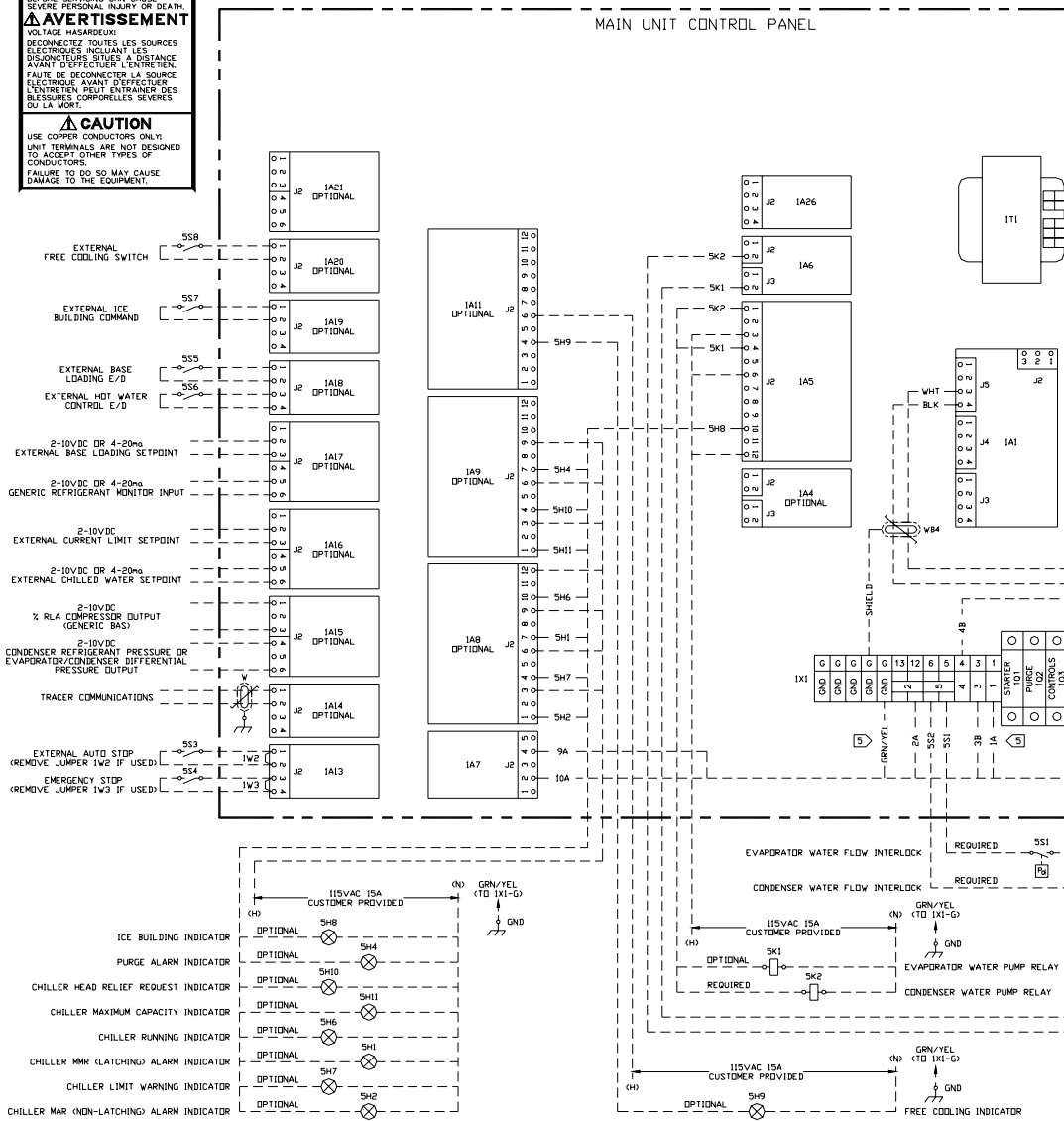

2309-2171 (Con't)

Trane supplied auto-transformer, primary reactor or across the line starter

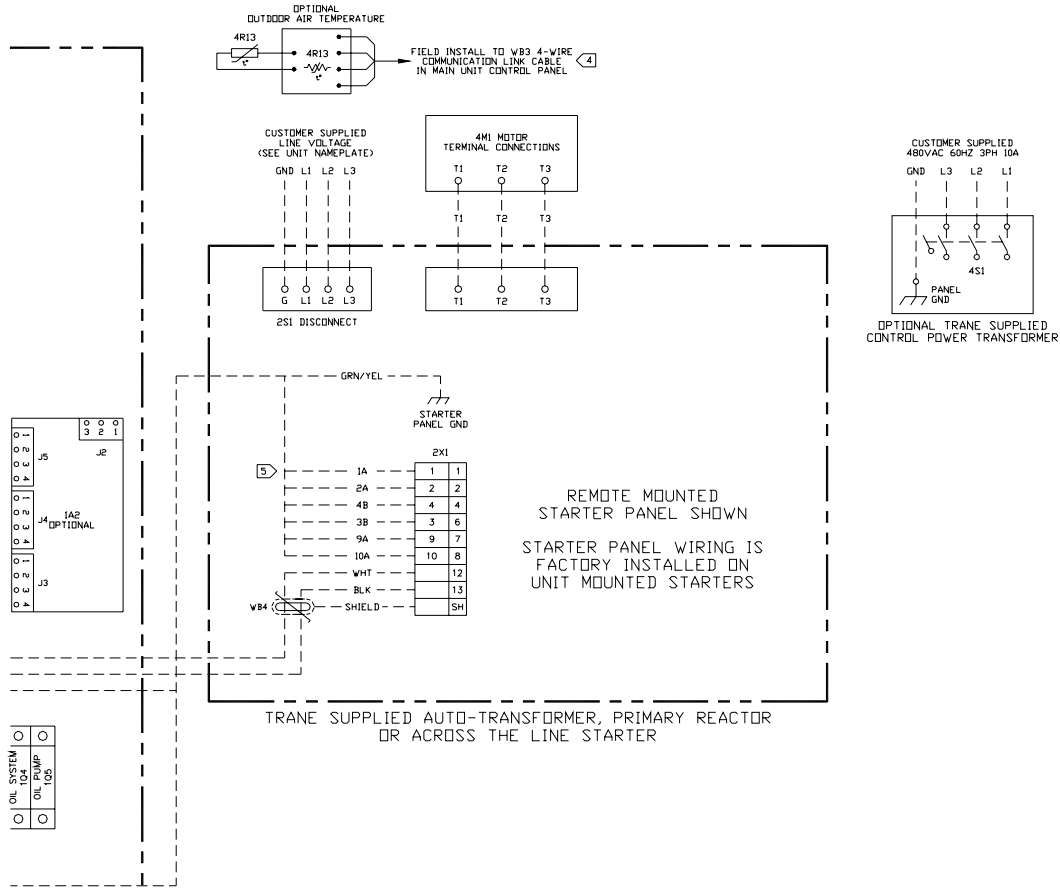

FIELD WIRING CIRCUIT SELECTION INFORMATION

WIRE NO OR DEVICE	CIRCUIT INFORMATION
SUPPLY AND MOTOR LEADS	SEE NAMEPLATE; MINIMUM CIRCUIT AMPACITY
1A*, 2A* AND GRN/YEL	4000VA AT 115 VAC, 8 AWG MAX WIRE SIZE
9A* AND 10A*	PUMP MOTOR; 1PH 3/4 HP, 11.7 FULL LOAD AMPS AT 115 VAC 14 AWG MAX WIRE SIZE
WB4	TWISTED, SHIELDED PAIR; 30 VDC, MAX LENGTH 1500 FT (BELDON TYPE 8760 RECOMMENDED)
5S1*, 5S2*, 3B* AND 4B*	CIRCUIT PROTECTED AT 20A, 115 VAC 1PH, 10 AWG MAX WIRE SIZE
5S3 THRU 5S8	24 VDC, 12mA RESISTIVE LOAD, 14 AWG MAX WIRE SIZE
ALL REMAINING CH530 LLLID TERMINALS	CONTACT RATING; 288A INDUCTIVE, 1/3 HP, 0.25KW AT 115 VAC 14 AWG MAX WIRE SIZE

* TAPPED CONTROL CONDUCTORS

NOTES:

- DASHED LINES INDICATE FIELD WIRING BY OTHERS. WIRE NUMBERS SHOWN ARE RECOMMENDED BY TRANE. CHECK SALES ORDER TO DETERMINE WHICH OPTIONS ARE PRESENT ON THE UNIT.
- DO NOT ROUTE LOW VOLTAGE (30V) WITH CONTROL VOLTAGE (115V) AND DO NOT POWER UNIT UNTIL CHECK-OUT AND START-UP PROCEDURES HAVE BEEN COMPLETED.
- EVAPORATOR AND CONDENSER WATER FLOW SWITCHES ARE REQUIRED AND MUST CONTAIN DPDT CONTACTS. THE SEPARATE FLOW SWITCHES ARE TO BE RUN IN SERIES WITH SEPARATE AUX CONTACTS FOR THE EVAPORATOR AND CONDENSER PUMPS. THEY MUST BE INSTALLED AND WIRED TO THE TRANE MAIN UNIT CONTROL PANEL BY THE INSTALLING CONTRACTOR. THE PURCHASE OF FLOW SWITCHES FROM TRANE IS OPTIONAL.
- OPTIONAL 4R13 OUTDOOR AIR TEMPERATURE SENSOR IS SHIPPED WITH THE UNIT FOR FIELD INSTALLATION. REFER TO THE UNIT INSTALLATION LITERATURE FOR INSTALLATION OPTIONS AT THE JOB SITE.
- WHEN CONTROL POWER TRANSFORMER (CPTB OPTION) IS PRESENT, WIRE 1A IS NOT REQUIRED. WIRE 2A CONNECTS TO J1-13 AND GRN/YEL STARTER PANEL GROUND WIRE IS CONNECTED ONE TERMINAL TO THE LEFT FROM WHERE IT IS CURRENTLY SHOWN ON 1X1.

2309-2173 (Con't) Customer supplied wye-delta or solid state starter

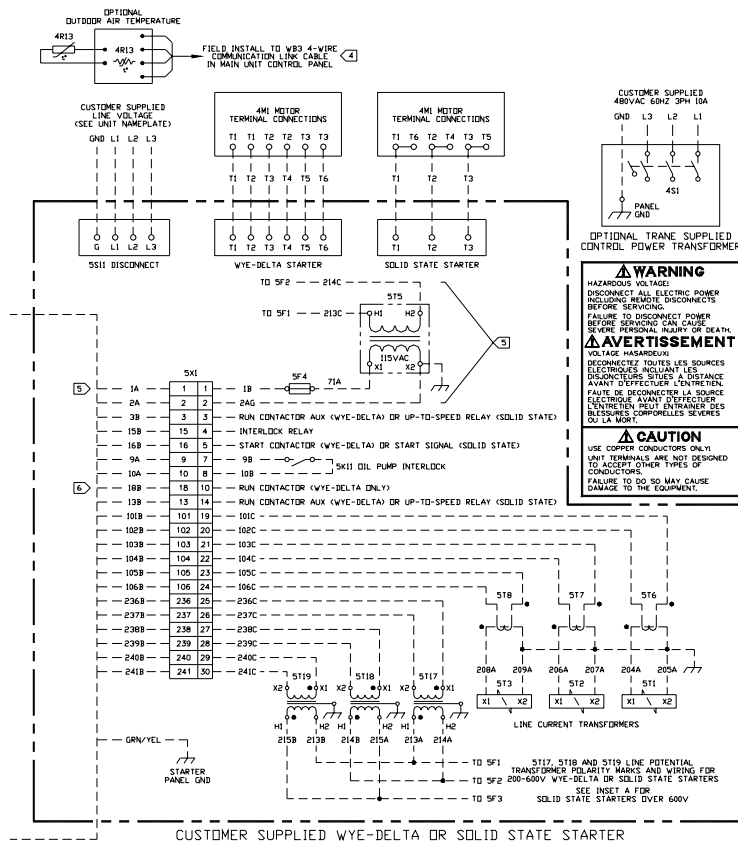

FIELD WIRING CIRCUIT SELECTION INFORMATION

WIRE NO OR DEVICE	CIRCUIT INFORMATION
SUPPLY AND MOTOR LEADS	SEE NAMEPLATE, MINIMUM CIRCUIT AMPACITY
1A*, 2A* AND GRN/YEL	4000VA AT 115 VAC, 8 AWG MAX WIRE SIZE
9A* AND 10A*	PUMP MOTOR, 1/4 HP, 11.7 FULL LOAD AMPS AT 115 VAC 14 AWG MAX WIRE SIZE
13B*, 15B*, 16B* AND 18B*	CONTACT RATING, 288A INDUCTIVE, 1/3 HP, 0.25KW AT 115 VAC 14 AWG MAX WIRE SIZE
10B THRU 106B	SEE TRANE SPECIFICATION S6516-0513, APPENDIX C 14 AWG MAX WIRE SIZE
236B THRU 241B	SEE TRANE SPECIFICATION S6516-0513, APPENDIX F
551*, 552* AND 3B*	CIRCUIT PROTECTED AT 20A, 115 VAC 1PH, 10 AWG MAX WIRE SIZE
5A10-K1 AND 553 THRU 55B	24 VDC, 120A RESISTIVE LOAD, 14 AWG MAX WIRE SIZE
ALL REMAINING CH530 L1-D TERMINALS	CONTACT RATING, 288A INDUCTIVE, 1/3 HP, 0.25KW AT 115 VAC 14 AWG MAX WIRE SIZE

* TAPPED CONTROL CONDUCTORS

NOTES:

- DASHED LINES INDICATE FIELD WIRING BY OTHERS. WIRE NUMBERS SHOWN ARE RECOMMENDED BY TRANE. CHECK SALES ORDER TO DETERMINE WHICH OPTIONS ARE PRESENT ON THE UNIT.
 - DO NOT ROUTE LOW VOLTAGE (200V) WITH CONTROL VOLTAGE (115V) AND DO NOT POWER UNIT UNTIL CHECK-OUT AND START-UP PROCEDURES HAVE BEEN COMPLETED.
 - EVAPORATOR AND CONDENSER WATER FLOW SWITCHES ARE REQUIRED AND MUST CONTAIN SPDT CONTACTS. THE SEPARATE FLOW SWITCHES ARE TO BE RUN IN SERIES WITH SEPARATE AUX CONTACTS FOR THE EVAPORATOR AND CONDENSER PUMPS. THEY MUST BE INSTALLED AND WIRED TO THE TRANE MAIN UNIT CONTROL PANEL BY THE INSTALLING CONTRACTOR. THE PURCHASE OF FLOW SWITCHES FROM TRANE IS OPTIONAL.
- ④ OPTIONAL 4813 OUTDOOR AIR TEMPERATURE SENSOR IS SHIPPED WITH THE UNIT FOR FIELD INSTALLATION. REFER TO THE UNIT INSTALLATION LITERATURE FOR INSTALLATION OPTIONS AT THE JOB SITE.
- ⑤ WHEN CONTROL POWER TRANSFORMER (CPTX OPT10) IS PRESENT, 5F4 AND 515 TRANSFORMERS AND ASSOCIATED WIRES ARE NOT REQUIRED. WIRE 1A IS NOT REQUIRED. WIRE 2A CONNECTS TO IX1-13 AND GRN/YEL STARTER PANEL. GROUND WIRE IS CONNECTED ONE TERMINAL TO THE LEFT FROM WHERE IT IS CURRENTLY SHOWN ON IX1.
- ⑥ WIRE 18B IS NOT USED WITH SOLID STATE STARTER

2309-2175 (Con't) Customer supplied auto-transformer, primary reactor or across the line starter

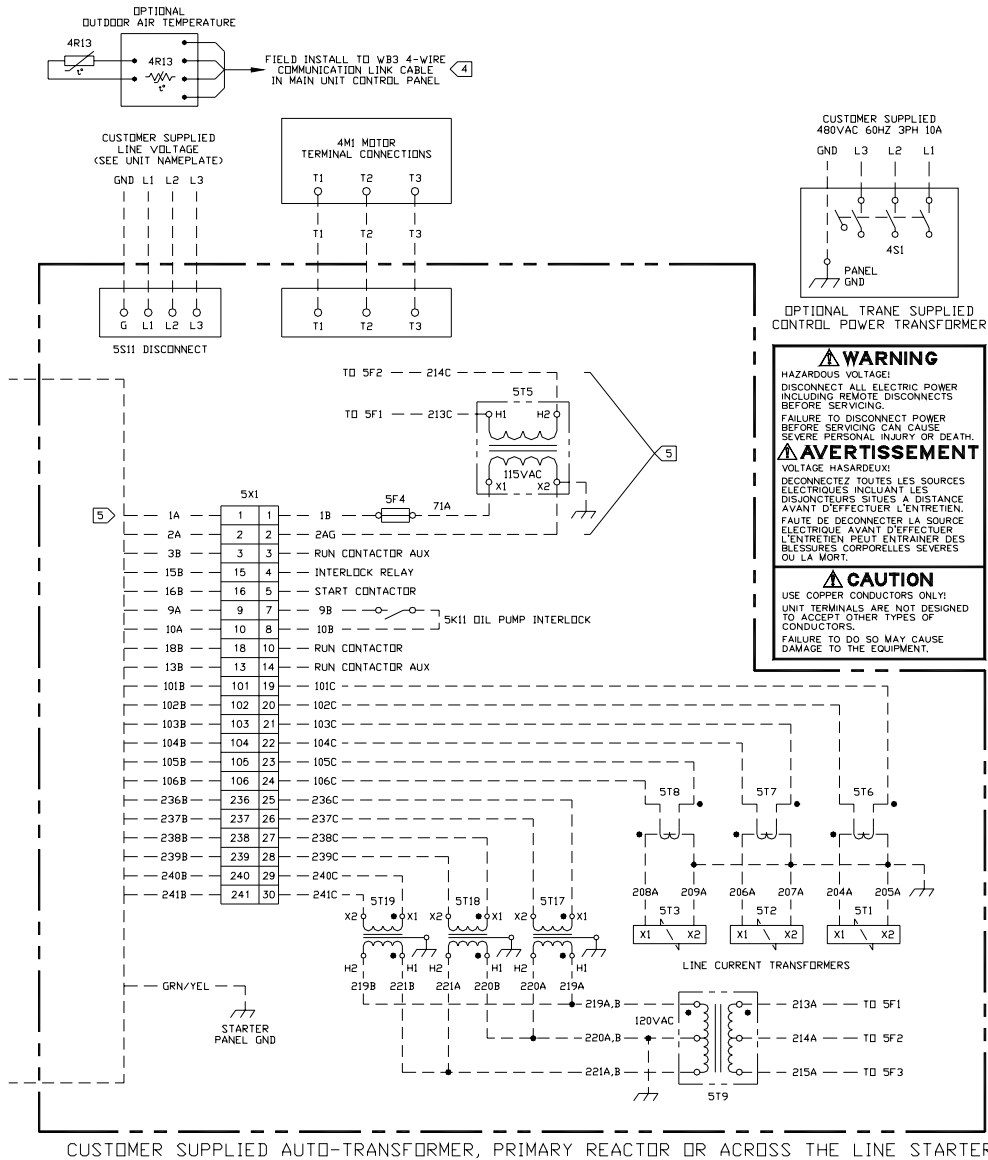

WARNING
HAZARDOUS VOLTAGE!
DISCONNECT ALL ELECTRIC POWER INCLUDING REMOTE DISCONNECTS BEFORE SERVICING.
FAILURE TO DISCONNECT POWER BEFORE SERVICING CAN CAUSE SEVERE PERSONAL INJURY OR DEATH.

AVERTISSEMENT
VOLTAGE HASARDEUX!
DECONNECTEZ TOUTES LES SOURCES ELECTRIQUES INCLUANT LES DISCONNECTEURS SITES A DISTANCE AVANT D'EFFECTUER L'ENTRETIEN.
FAUTE DE DECONNECTER LA SOURCE ELECTRIQUE AVANT D'EFFECTUER L'ENTRETIEN PEUT ENTRAINER DES BLESSURES CORPORELLES SEVERES OU LA MORT.

CAUTION
USE COPPER CONDUCTORS ONLY!
UNIT TERMINALS ARE NOT DESIGNED TO ACCEPT OTHER TYPES OF CONDUCTORS.
FAILURE TO DO SO MAY CAUSE DAMAGE TO THE EQUIPMENT.

CUSTOMER SUPPLIED AUTO-TRANSFORMER, PRIMARY REACTOR OR ACROSS THE LINE STARTER

FIELD WIRING CIRCUIT SELECTION INFORMATION

WIRE NO OR DEVICE	CIRCUIT INFORMATION
SUPPLY AND MOTOR LEADS	SEE NAMEPLATE, MINIMUM CIRCUIT AMPACITY
1A*, 2A* AND GRN/YEL	4000VA AT 115 VAC, 8 AWG MAX WIRE SIZE
9A* AND 10A*	PUMP MOTOR, 1PH 3/4 HP, 11.7 FULL LOAD AMPS AT 115 VAC, 14 AWG MAX WIRE SIZE
13B*, 15B*, 16B* AND 18B*	CONTACT RATING: 2,88A INDUCTIVE, 1/3 HP, 0.25KW AT 115 VAC, 14 AWG MAX WIRE SIZE
101B THRU 106B	SEE TRANE SPECIFICATION S6516-0513, APPENDIX C
236B THRU 241B	SEE TRANE SPECIFICATION S6516-0513, APPENDIX F
5S1*, 5S2* AND 3B*	CIRCUIT PROTECTED AT 20A, 115 VAC 1PH, 10 AWG MAX WIRE SIZE
5S3 THRU 5S8	24 VDC, 12mA RESISTIVE LOAD, 14 AWG MAX WIRE SIZE
ALL REMAINING CH530 LLID TERMINALS	CONTACT RATING: 2,88A INDUCTIVE, 1/3 HP, 0.25KW AT 115 VAC, 14 AWG MAX WIRE SIZE

* TAPPED CONTROL CONDUCTORS

NOTES:

- DASHED LINES INDICATE FIELD WIRING BY OTHERS. WIRE NUMBERS SHOWN ARE RECOMMENDED BY TRANE. CHECK SALES ORDER TO DETERMINE WHICH OPTIONS ARE PRESENT ON THE UNIT.
- DO NOT ROUTE LOW VOLTAGE (30V) WITH CONTROL VOLTAGE (115V) AND DO NOT POWER UNIT UNTIL CHECK-OUT AND START-UP PROCEDURES HAVE BEEN COMPLETED.
- EVAPORATOR AND CONDENSER WATER FLOW SWITCHES ARE REQUIRED AND MUST CONTAIN DPDT CONTACTS. THE SEPARATE FLOW SWITCHES ARE TO BE RUN IN SERIES WITH SEPARATE AUX CONTACTS FOR THE EVAPORATOR AND CONDENSER PUMPS. THEY MUST BE INSTALLED AND WIRED TO THE TRANE MAIN UNIT CONTROL PANEL BY THE INSTALLING CONTRACTOR. THE PURCHASE OF FLOW SWITCHES FROM TRANE IS OPTIONAL.
- OPTIONAL 4R13 OUTDOOR AIR TEMPERATURE SENSOR IS SHIPPED WITH THE UNIT FOR FIELD INSTALLATION. REFER TO THE UNIT INSTALLATION LITERATURE FOR INSTALLATION OPTIONS AT THE JOB SITE.
- WHEN CONTROL POWER TRANSFORMER (CPTR OPT'D) IS PRESENT, 5F4 FUSE, 5T5 TRANSFORMER AND ASSOCIATED WIRES ARE NOT REQUIRED. WIRE 1A IS NOT REQUIRED, WIRE 2A CONNECTS TO X1-13 AND GRN/YEL STARTER PANEL GROUND WIRE IS CONNECTED ONE TERMINAL TO THE LEFT FROM WHERE IT IS CURRENTLY SHOWN ON IX1.

2309-2177

Trane supplied LiquiFlo 2 adaptive frequency drive

WARNING
HAZARDOUS VOLTAGE!
DISCONNECT ALL ELECTRIC POWER INCLUDING REMOTE DISCONNECTS BEFORE SERVICING.
FAILURE TO DISCONNECT POWER BEFORE SERVICING CAN CAUSE SEVERE PERSONAL INJURY OR DEATH.

AVERTISSEMENT
VOLTAGE HASARDEUX!
DECONNECTEZ TOUTES LES SOURCES ELECTRIQUES INCLUANT LES DISJONCTEURS SITUÉS A DISTANCE AVANT D'EFFECTUER L'ENTRETIEN.
FAUTE DE DECONNECTER LA SOURCE ELECTRIQUE AVANT D'EFFECTUER L'ENTRETIEN PEUT ENTRAÎNER DES BLESSURES CORPORELLES SEVERES OU LA MORT.

CAUTION
USE COPPER CONDUCTORS ONLY!
UNIT TERMINALS ARE NOT DESIGNED TO ACCEPT OTHER TYPES OF CONDUCTORS.
FAILURE TO DO SO MAY CAUSE DAMAGE TO THE EQUIPMENT.

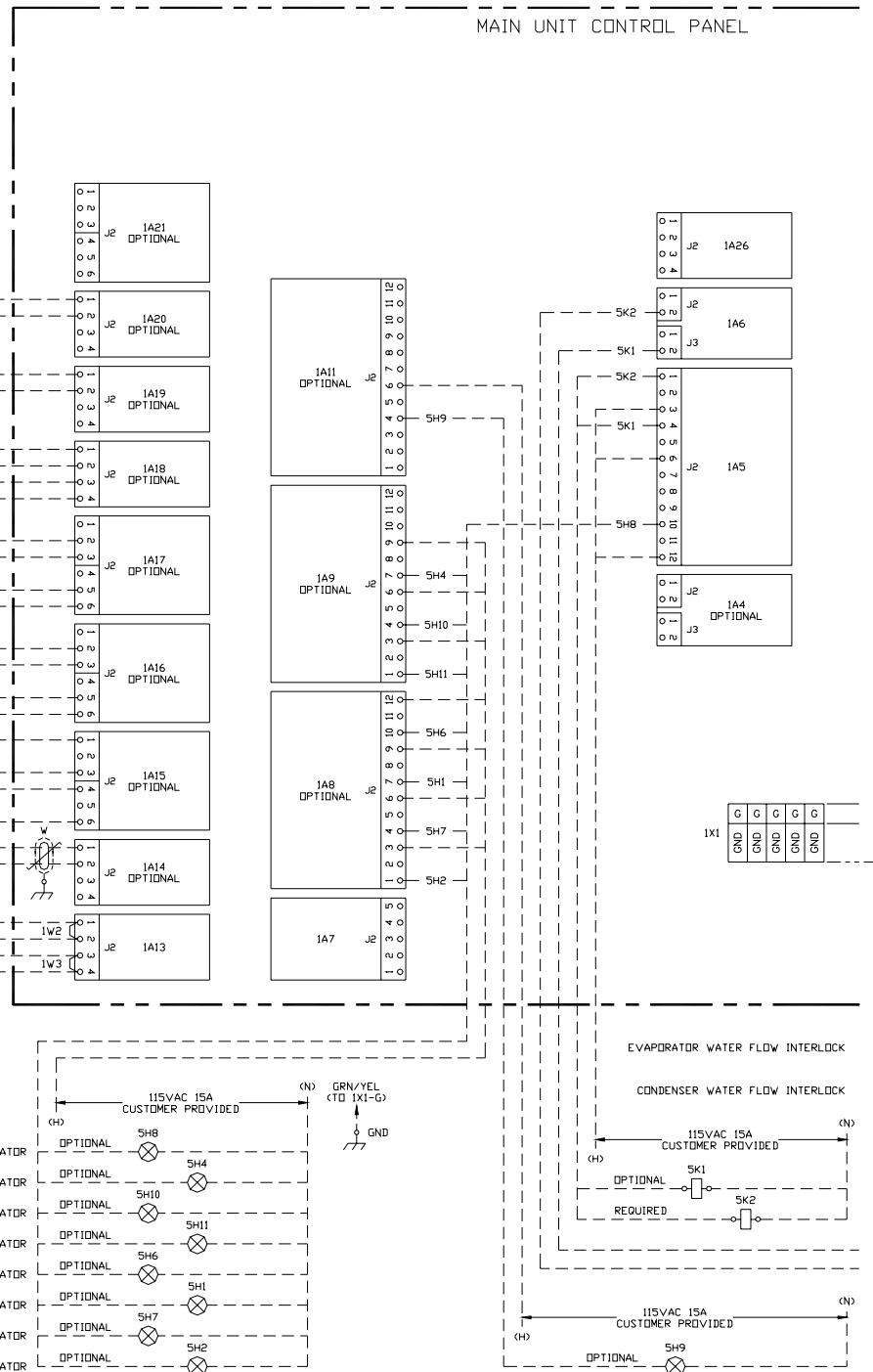

2309-2177 (Con't) Trane supplied LiquiFlo 2 adaptive frequency drive

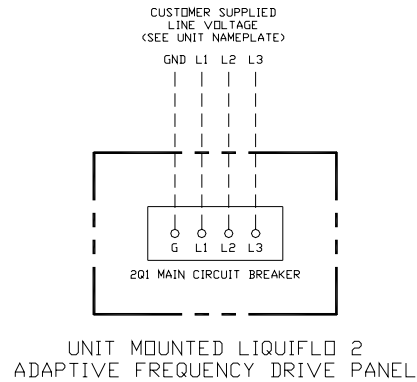
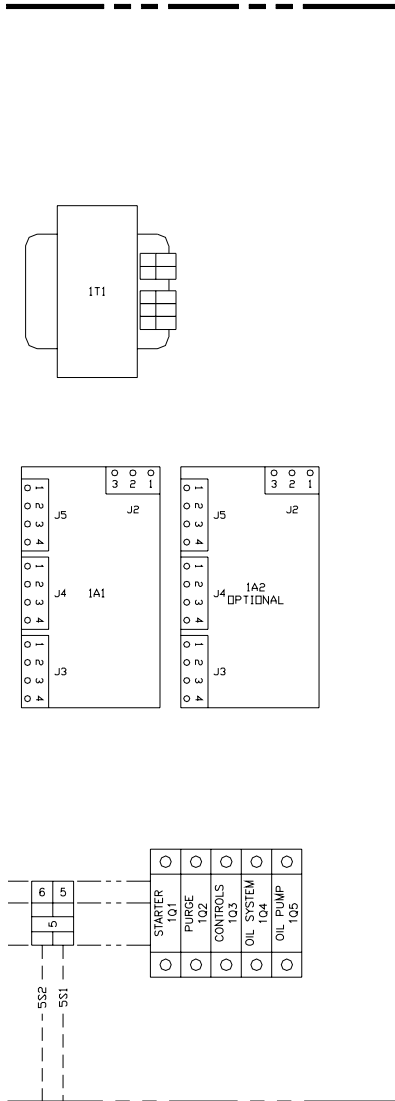

FIELD WIRING CIRCUIT SELECTION INFORMATION

WIRE NO OR DEVICE	CIRCUIT INFORMATION
SUPPLY AND MOTOR LEADS	SEE NAMEPLATE; MINIMUM CIRCUIT AMPACITY
5S1*, 5S2*	CIRCUIT PROTECTED AT 20A, 115 VAC 1PH, 10 AWG MAX WIRE SIZE
5S3 THRU 5S8	24 VDC, 12mA RESISTIVE LOAD, 14 AWG MAX WIRE SIZE
ALL REMAINING CH530 LL1D TERMINALS	CONTACT RATING; 2.88A INDUCTIVE, 1/3 HP, 0.25KW AT 115 VAC 14 AWG MAX WIRE SIZE

* TAPPED CONTROL CONDUCTORS

NOTES:

- DASHED LINES INDICATE FIELD WIRING BY OTHERS. WIRE NUMBERS SHOWN ARE RECOMMENDED BY TRANE. CHECK SALES ORDER TO DETERMINE WHICH OPTIONS ARE PRESENT ON THE UNIT.
- DO NOT ROUTE LOW VOLTAGE (30V) WITH CONTROL VOLTAGE (115V) AND DO NOT POWER UNIT UNTIL CHECK-OUT AND START-UP PROCEDURES HAVE BEEN COMPLETED.
- EVAPORATOR AND CONDENSER WATER FLOW SWITCHES ARE REQUIRED AND MUST CONTAIN DPDT CONTACTS. THE SEPARATE FLOW SWITCHES ARE TO BE RUN IN SERIES WITH SEPARATE AUX CONTACTS FOR THE EVAPORATOR AND CONDENSER PUMPS. THEY MUST BE INSTALLED AND WIRED TO THE TRANE MAIN UNIT CONTROL PANEL BY THE INSTALLING CONTRACTOR. THE PURCHASE OF FLOW SWITCHES FROM TRANE IS OPTIONAL.
- OPTIONAL 4R13 OUTDOOR AIR TEMPERATURE SENSOR IS SHIPPED WITH THE UNIT FOR FIELD INSTALLATION. REFER TO THE UNIT INSTALLATION LITERATURE FOR INSTALLATION OPTIONS AT THE JOB SITE.

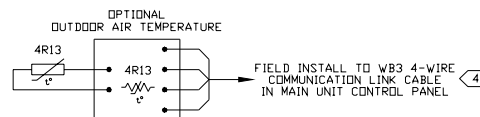
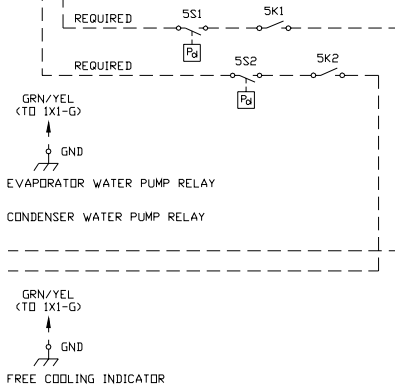

2309-2181

Unit mounted controls used with all starters and adaptive frequency drives

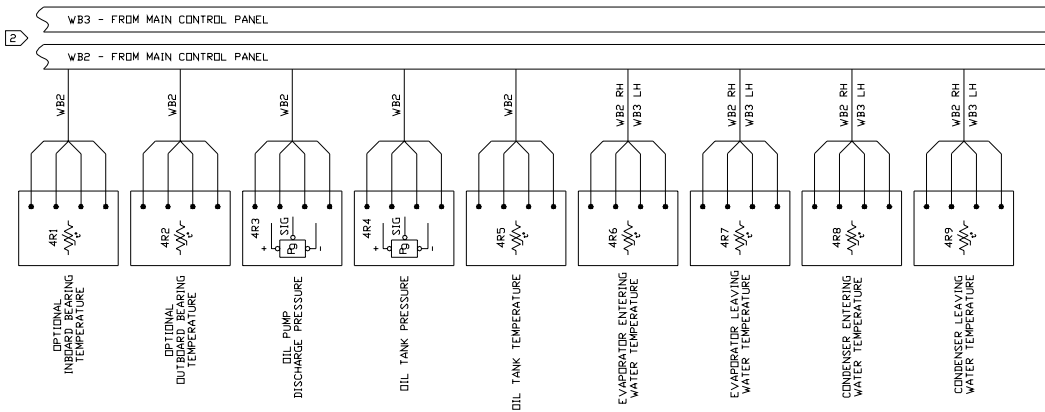
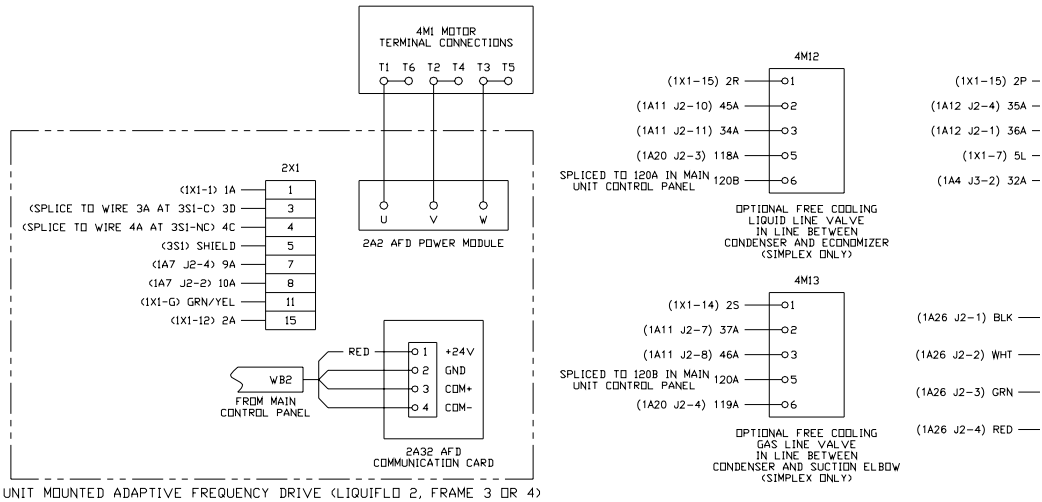
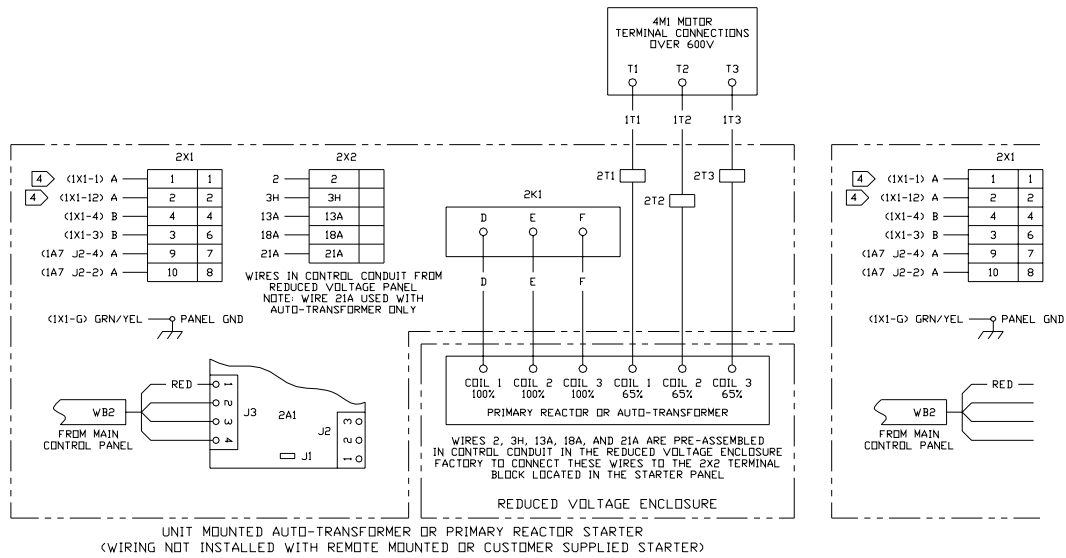

2309-2181 (Con't)

Unit mounted controls used with all starters and adaptive frequency drives

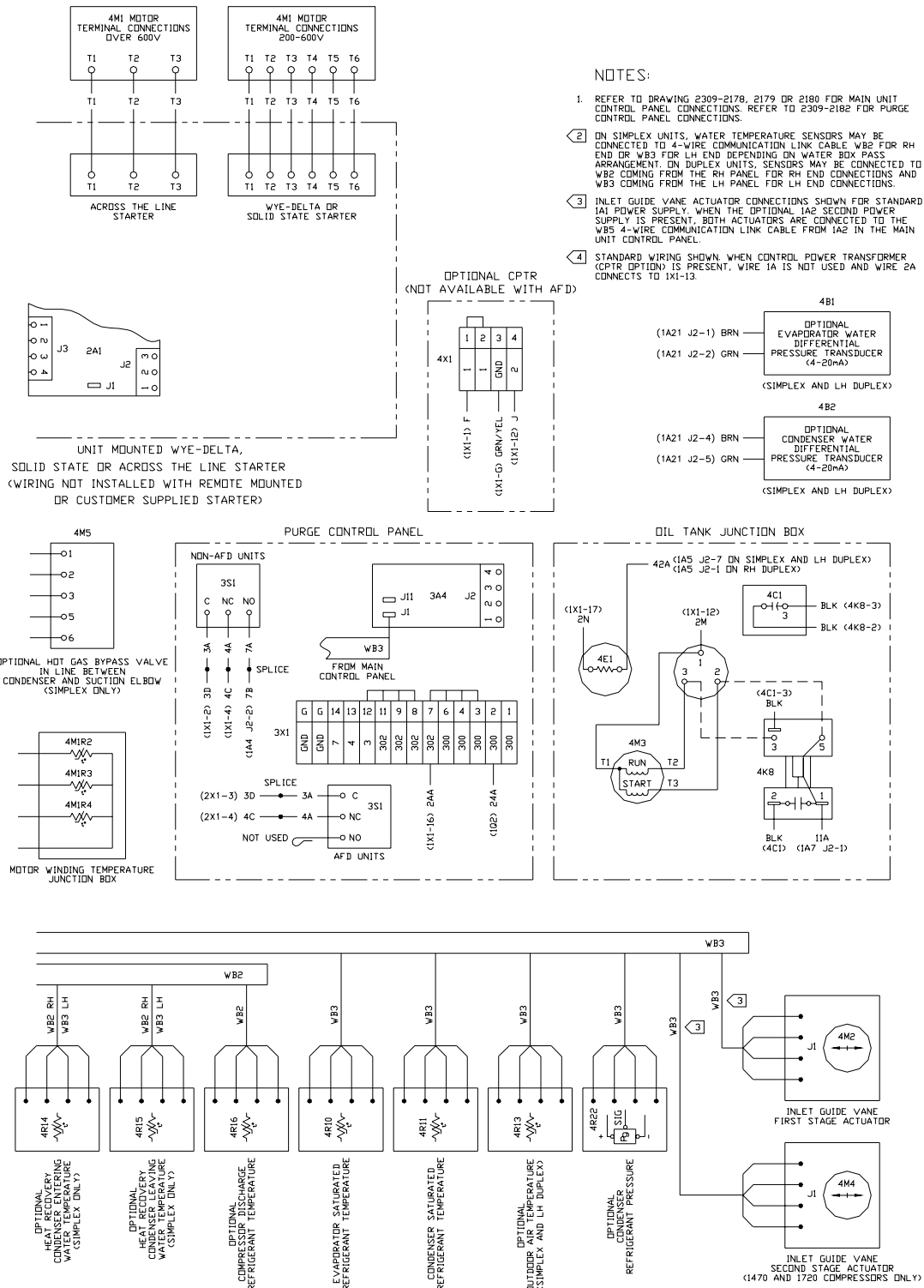

2309-2182 CH530 schematic wiring diagram device descriptions

NOTE: DEVICES LISTED MAY NOT ALWAYS APPEAR ON SCHEMATIC WIRING DIAGRAM

DEVICE	DESCRIPTION	PAGE	DEVICE	DESCRIPTION	PAGE
1A1	24VDC POWER SUPPLY NO. 1	2	3R1	PURGE COMPRESSOR REFRIGERANT SUCTION TEMPERATURE SENSOR	4
1A2	24VDC POWER SUPPLY NO. 2	2	3R2	PURGE CARBON TANK TEMPERATURE SENSOR	4
1A4	CONDENSER HIGH PRESSURE CUTOUT SWITCH INPUT	2	3R3	PURGE CONDENSER SATURATED REFRIGERANT TEMPERATURE SENSOR	4
1A5(1)(2)	EVAPORATOR AND CONDENSER WATER PUMP, OIL TANK HEATER AND ICE BUILDING INDICATOR RELAYS	3	3R4	CONDENSER REFRIGERANT PRESSURE TRANSDUCER	4
1A5 (3)	OIL TANK HEATER CONTROL RELAY	3	3S1	CONDENSER HIGH PRESSURE CUTOUT SWITCH	1
1A6	EVAPORATOR AND CONDENSER WATER FLOW SWITCH/INTERLOCK INPUTS	3	3S9	PURGE LIQUID LEVEL SWITCH	4
1A7	OIL/REFRIGERANT PUMP MOTOR CONTROL RELAY	3	3T1	PURGE AUTO-TRANSFORMER	4
1A8 (1)	NON-LATCHING AND LATCHING ALARM LIMIT MODE AND RUNNING INDICATOR RELAYS	5	3T2	PURGE CONTROL PANEL TERMINAL BLOCK	4
1A8 (2)	OPERATING STATUS PROGRAMMABLE RELAYS	5	3X1	DIFFERENTIAL MOTOR PROTECTION RELAY	1
1A9 (1)	HEAD RELIEF REQUEST, MAXIMUM CAPACITY AND PURGE ALARM INDICATOR RELAYS	5	4B1	EVAPORATOR WATER DIFFERENTIAL PRESSURE TRANSDUCER	3
1A9(2)(3)	OPERATING STATUS PROGRAMMABLE RELAYS	5	4B2	CONDENSER WATER DIFFERENTIAL PRESSURE TRANSDUCER	3
1A11	FREE COOLING RELAY OUTPUTS	3	4C1	OIL/REFRIGERANT PUMP MOTOR CAPACITOR	3
1A12	HOT GAS BYPASS VALVE CONTROL RELAY	3	4E1	OIL TANK HEATER	3
1A13	EXTERNAL AUTO-STOP AND EMERGENCY STOP INPUTS	2	4F1,2	CONTROL POWER PRIMARY FUSING	2
1A14	COMMA OR COMMS MODULE	5	4F3	CONTROL POWER SECONDARY FUSE	2
1A15	% RLA COMPRESSOR AND CONDENSER REFRIGERANT PRESSURE OUTPUTS	5	4F4,5,6	LIGHTNING ARRESTORS	1
1A16	EXTERNAL CURRENT LIMIT AND CHILLED WATER SETPOINT INPUTS	5	4F7,8,9	SURGE CAPACITORS	1
1A17	EXTERNAL BASE LOADING AND EXTERNAL HOT WATER CONTROL ENABLE/DISABLE INPUTS	5	4H1	CONTROL POWER INDICATOR	2
1A18	EXTERNAL ICE BUILDING COMMAND INPUT	5	4K8	OIL/REFRIGERANT PUMP MOTOR CONTROL RELAY	2
1A19	EXTERNAL FREE COOLING COMMAND AND FREE COOLING VALVES CLOSED INPUTS	5	4K9	GROUND FAULT RELAY	1
1A20	EVAPORATOR AND CONDENSER WATER DIFFERENTIAL PRESSURE INPUTS	3	4M1	COMPRESSOR MOTOR	1
1A21	DYNVIEW	2	4M2	INLET GUIDE VANE FIRST STAGE ACTUATOR	2
1A22	STARTER MODULE	1	4M3	OIL/REFRIGERANT PUMP MOTOR	2
1A23	STARTER FAULT INPUT	2	4M4	INLET GUIDE VANE SECOND STAGE ACTUATOR	2
1A25	CIRCUIT 1 AND 2 EXTERNAL LOCKOUT INPUTS	1	4M5	HOT GAS BYPASS VALVE	2,3
1A26	MOTOR WINDING TEMPERATURE 1, 2 AND 3 INPUTS	2	4M12	FREE COOLING LIQUID LINE VALVE	3
1A30	EVAPORATOR LOW WATER TEMPERATURE CUTOUT CONTROL	2	4M13	FREE COOLING GAS LINE VALVE	3
1K1	BREAKER CONTROL RELAY - CLOSE	1	4R1	MOTOR WINDING TEMPERATURE 1, 2 AND 3	2
1K2	BREAKER CONTROL RELAY - OPEN	1	4R2	INBOARD BEARING TEMPERATURE SENSOR	2
1O1	STARTER CONTROL CIRCUIT BREAKER	2	4R3	OIL PUMP DISCHARGE PRESSURE TRANSDUCER	2
1O2	PURGE CONTROL CIRCUIT BREAKER	2	4R4	OIL TANK PRESSURE TRANSDUCER	2
1O3	LIMIT CONTROL CIRCUIT BREAKER	2	4R5	OIL TANK TEMPERATURE SENSOR	2
1O4	OIL/REFRIGERANT CONTROL CIRCUIT BREAKER	2	4R6	EVAPORATOR ENTERING WATER TEMPERATURE SENSOR	3
1O5	OIL/REFRIGERANT PUMP MOTOR CIRCUIT BREAKER	2	4R7	EVAPORATOR LEAVING WATER TEMPERATURE SENSOR	3
1S1	POTENTIAL TRANSFORMER DISCONNECT SWITCH	1	4R8	CONDENSER ENTERING WATER TEMPERATURE SENSOR	3
1T2,3,4	LINE POTENTIAL TRANSFORMERS	1	4R9	CONDENSER LEAVING WATER TEMPERATURE SENSOR	3
1W1	JUMPER BAR	2	4R10	EVAPORATOR SATURATED REFRIGERANT TEMPERATURE SENSOR	3
1W2,3,4,5	MAIN CONTROL PANEL TERMINAL BLOCKS	1,2,3	4R11	CONDENSER LEAVING WATER TEMPERATURE SENSOR	3
1X1,2	STARTER MODULE	1	4R13	OUTDOOR AIR TEMPERATURE SENSOR	3
2A2	ADAPTIVE FREQUENCY DRIVE	1	4R14	HEAT RECOVERY CONDENSER ENTERING WATER TEMPERATURE SENSOR	3
2A3	STARTER POWER SUPPLY	1	4R15	HEAT RECOVERY CONDENSER LEAVING WATER TEMPERATURE SENSOR	3
2A4	SOLID STATE STARTER	1	4R16	COMPRESSOR DISCHARGE REFRIGERANT TEMPERATURE SENSOR	3
2A4-K1	STARTER FAULT CONTROL RELAY	1	4R22	CONDENSER REFRIGERANT PRESSURE TRANSDUCER	3
2A4-K2	AT-SPEED CONTROL RELAY	1	4R23	EVAPORATOR LOW WATER TEMPERATURE SENSOR	2
2A5 (1)	STARTER FAULT INPUT	1	4S1	CONTROL POWER DISCONNECT SWITCH	2
2A5 (4)	INPUT INDUCTOR	1	4T1,2,3	LINE CURRENT TRANSFORMERS	1
2A6	FILTER CAPACITORS	1	4T5	CONTROL POWER TRANSFORMER	2
2A7 (4)	LINE SYNC PCB	1	4T6,7,8	DIFFERENTIAL MOTOR PROTECTION CURRENT TRANSFORMERS	1
2A7 (5)	ENGINE-GENERATOR START/STOP CONTROL RELAY	1	4T15	GROUND FAULT TORROID	1
2A8	ENGINE-GENERATOR UP-TO-SPEED/FREQUENCY AND STARTER DRIVE FAULT INPUTS	1	4X1	CONTROL POWER TRANSFORMER TERMINAL BLOCK	2
2A9	ENGINE-GENERATOR SPEED SIGNAL OUTPUT	1	4X2	SUPPLEMENTAL MOTOR PROTECTION TERMINAL BLOCK	1,2
2A12	ADAPTIVE FREQUENCY DRIVE AC LINE I/O	1	5A10	SOLID STATE STARTER	1
2A32	ADAPTIVE FREQUENCY DRIVE COMMUNICATION CARD	1	5A10-K1	STARTER FAULT CONTROL RELAY	1
2A33	ADAPTIVE FREQUENCY DRIVE GATE-KILL	1	5A10-K2	AT-SPEED CONTROL RELAY	1
			5F1,2,3	CONTROL POWER PRIMARY FUSING	1

2309-2182 (Con't) CH530 schematic wiring diagram device descriptions

5F4	CONTROL POWER SECONDARY FUSE	1
5H1	CHILLER LATCHING ALARM INDICATOR	5
5H2	CHILLER NON-LATCHING ALARM INDICATOR	5
5H4	PURGE ALARM INDICATOR	5
5H4 (2)	CIRCUIT 2 PURGE ALARM INDICATOR	5
5H6	CHILLER RUNNING INDICATOR	5
5H7	CHILLER LIMIT MODE INDICATOR	5
5H8	ICE BUILDING INDICATOR	3
5H9	FREE COOLING INDICATOR	3
5H10	CHILLER HEAD RELIEF REQUEST INDICATOR	5
5H11	CHILLER MAXIMUM CAPACITY INDICATOR	5
5H12	CIRCUIT 1 PURGE ALARM INDICATOR	5
5H13	CIRCUIT 1 RUNNING INDICATOR	5
5H14	CIRCUIT 2 RUNNING INDICATOR	5
5H15	CHILLER ALARM INDICATOR	5
5H16	CIRCUIT 1 ALARM INDICATOR	5
5H17	CIRCUIT 2 ALARM INDICATOR	5
6H18	PURGE ALARM INDICATOR	5
8K1	EVAPORATOR WATER PUMP CONTROL RELAY	3
8K2	CONDENSER WATER PUMP CONTROL RELAY	3
8K11	OIL PUMP INTERLOCK RELAY	1
8K12	START CONTACTOR	1
8K13	RUN CONTACTOR	1
8K91	PURGE CHILLER RUNNING RELAY	4
5S1	EVAPORATOR WATER FLOW SWITCH/INTERLOCK	3
5S2	CONDENSER WATER FLOW SWITCH/INTERLOCK	3
5S3	EXTERNAL AUTO-STOP SWITCH	2
5S4	EMERGENCY STOP SWITCH	2
5S5	EXTERNAL BASE LOADING ENABLE/DISABLE SWITCH	5
5S6	EXTERNAL HOT WATER CONTROL ENABLE/DISABLE SWITCH	5
5S7	EXTERNAL ICE BUILDING COMMAND SWITCH	5
5S8	EXTERNAL FREE COOLING SWITCH	3
5S9	CIRCUIT 1 EXTERNAL LOCKOUT SWITCH	3
5S10	CIRCUIT 2 EXTERNAL LOCKOUT SWITCH	3
5S11	LINE POTENTIAL FUSED DISCONNECT SWITCH	1
5S12	VACUUM CIRCUIT BREAKER AUXILIARY SWITCH	1
5T1,2,3	LINE CURRENT TRANSFORMERS	1
5T5	CONTROL POWER TRANSFORMER	1
5T6,7,8	SECONDARY LINE CURRENT TRANSFORMERS	1
5T9	LINE POTENTIAL TRANSFORMER	1
5T17,18,19	LINE POTENTIAL TRANSFORMERS	1
6X1	TERMINAL BLOCK	1
6K1	ENGINE-GENERATOR START-STOP CONTROL	1
6K2	ENGINE-GENERATOR DRIVE FAULT CONTROL	1
6K3	ENGINE-GENERATOR UP-TO-SPEED/FREQUENCY CONTROL	1
6Q1	ENGINE-GENERATOR CIRCUIT BREAKER	1
6X1,12,6	ENGINE-GENERATOR TERMINAL BLOCKS	1
7K2	RUN CONTACTOR	1
7K3	SHORTING CONTACTOR	1
7R1,2,3	TRANSITION RESISTORS	1

THIS DRAWING IS PROPRIETARY AND SHALL NOT BE REPRODUCED OR COPIED IN ANY MANNER WITHOUT THE WRITTEN CONSENT OF TRANE

DEVICE LOCATION PREFIX CODE
 1 = MAIN CONTROL PANEL
 2 = STARTER PANEL OR ADAPTIVE FREQUENCY DRIVE
 3 = PURGE DEVICE
 4 = UNIT MOUNTED DEVICE
 5 = PROVIDED BY OTHERS
 6 = ENGINE DRIVEN GENERATOR
 7 = REDUCED VOLTAGE PANEL

2C1	POWER FACTOR CORRECTION CAPACITORS	1
2F1,2,3	CONTROL POWER PRIMARY FUSING	1
2F1,2 (4)	PRIMARY TRANSFORMER FUSING	1
2F3 (4)	CONTROL POWER SECONDARY FUSE	1
2F4	CONTROL POWER SECONDARY FUSE	1
2F4,5,6 (4)	PRIMARY FILTER CAPACITOR FUSING	1
2F7,8,9	PRIMARY LINE SYNC FUSING	1
2F10,11,12	PRIMARY PRECHARGE RESISTOR FUSING	1
2F13	CONTROL POWER SECONDARY FUSE	1
2K1	START CONTACTOR	1
2K2	RUN CONTACTOR	1
2K3	SHORTING CONTACTOR	1
2K3 (4)	COOLANT CIRCULATING PUMP PILOT CONTROL RELAY	1
2K4	TRANSITION CONTACTOR	1
2K4 (4)	PRECHARGE CONTACTOR	1
2K5	CONTROL POWER INTERPOSING RELAY	1
2K7	CONDENSER-HIGH PRESSURE CUTOFF CONTROL RELAY	1
2K9	GROUND FAULT RELAY	1
2X10	POWER FACTOR CORRECTION CAPACITOR ISOLATION CONTACTOR	1
2X11	OIL PUMP INTERLOCK RELAY	1
2M12,3,4	COOLING FAN MOTORS	1
2Q1	LINE POTENTIAL MAIN CIRCUIT BREAKER	1
2Q2	CONTROL POWER SECONDARY CIRCUIT BREAKER	1
2Q2K1	TEST RUN CONTROL RELAY	1
2R1,2,3	TRANSITION RESISTORS	1
2R4,5,6	PRECHARGE RESISTORS	1
2S1	LINE POTENTIAL FUSED OR NON-FUSED DISCONNECT SWITCH	1
2S2	CONTROL POWER DISCONNECT SWITCH	1
2T1,2,3	LINE CURRENT TRANSFORMERS	1
2T5	CONTROL POWER TRANSFORMER	1
2T8,9	LINE POTENTIAL TRANSFORMERS	1
2T15	GROUND FAULT TORROID	1
2T17,18,19	LINE POTENTIAL TRANSFORMERS	1
2V1,2,3	METAL OXIDE VARISTORS	1
2W1	JUMPER WIRE	1
2X1,2	STARTER PANEL TERMINAL BLOCKS	1
2X3	LINE POTENTIAL TERMINAL BLOCK	1
3A1	PURGE PUMP/OUT AND EXHAUST VALVE CONTROL	4
3A2	PURGE CONDENSING UNIT CONTROL RELAY	4
3A3	PURGE PUMP/OUT CARBON TANK HEATER, REGENERATION VALVE AND ALARM RELAYS	4
3A4	PURGE LIQUID LEVEL SWITCH INPUT	4
3A5	PURGE POWER SUPPLY	4
3A6	PURGE CHILLER RUNNING INPUT	4
3A10	PURGE DYNAMVIEW	4
3C5	PURGE CONDENSING UNIT MOTOR CAPACITOR	4
3C6	PURGE PUMP/OUT COMPRESSOR MOTOR CAPACITOR	4
3E1	PURGE CARBON TANK HEATER	4
3F1	PURGE AUTO-TRANSFORMER FUSE	4
3L1	PURGE EXHAUST VALVE	4
3L2	PURGE PUMP/OUT VALVE	4
3L3	PURGE REGENERATION VALVE	4
3M5	PURGE CONDENSING UNIT MOTOR	4
3M6	PURGE PUMP/OUT COMPRESSOR MOTOR	4
3M7	PURGE CONDENSING UNIT FAN MOTOR	4

NOTE:
 (1) = AS USED ON CVHE, CVHF AND CVHG UNITS.
 (2) = AS USED ON LH CIRCUIT OF CDHF AND CDHG UNITS.
 (3) = AS USED ON RH CIRCUIT OF CDHF AND CDHG UNITS.
 (4) = AS USED WITH ADAPTIVE FREQUENCY DRIVE STARTERS.
 (5) = AS USED WITH ENGINE-GENERATOR SET.



Trane
A business of American Standard Companies
www.trane.com

For more information, contact your local Trane office or e-mail us at comfort@trane.com

Literature Order Number	CVHE-SVN03E-EN
Date	December 2005
Supersedes	CVHE-SVN03D-EN
Stocking Location	Print on Demand

Trane has a policy of continuous product and product data improvement and reserves the right to change design and specifications without notice.