

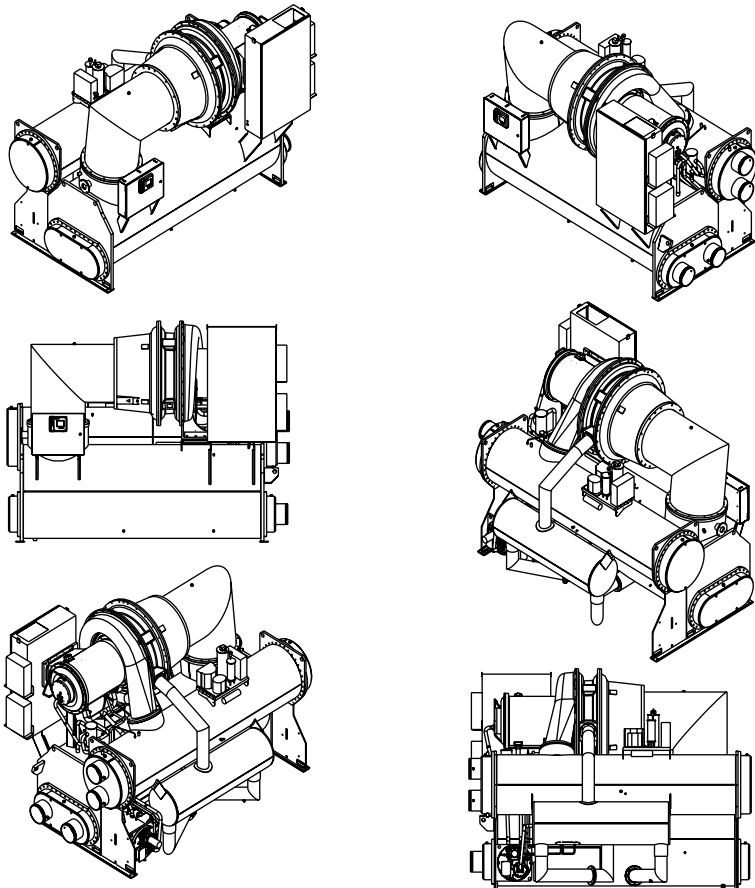

# Installation – Electrical Information

---

## Water-Cooled CenTraVac™ With CH530



### Required Installation Information:

CVHE-SVN01A-EN – General Information

CVHE-SVN02A-EN – Piping Information

CVHE-SVN03B-EN – Electrical Information



# Warnings and Cautions

---

## NOTICE:

Warnings and Cautions appear at appropriate sections throughout this manual.  
Read these carefully.

**▲ WARNING** - Indicates a potentially hazardous situation which, if not avoided, could result in death or serious injury.

**▲ CAUTION** - Indicates a potentially hazardous situation which, if not avoided, may result in minor or moderate injury. It may also be used to alert against unsafe practices.

**CAUTION** - Indicates a situation that may result in equipment or property-damage-only accidents.

# Contents

---

<b>Warnings and Cautions</b>	2
<b>Electrical Information - General</b>	4
<b>Electrical Information - Power Supply</b>	8
<b>Electrical Information - PFCC</b>	9
<b>Electrical Information - Unit Mounted Starter</b>	10
<b>Electrical Information - Remote Starter</b>	11
<b>Electrical Information - Motor Lugs</b>	13
<b>Electrical Information - Field Control Panel Signal Wiring</b>	15
<b>Wiring Diagrams</b>	19
<b>Legend</b>	66



# Electrical Information

## General

**Note:** Unit-mounted starters are available as an option on most CVHE, CVHF, and CVHG units with wye delta, and solid-state starters, with nominal voltages of up to 600 volts and unit mounted medium voltage across-the-line starters..

While this option eliminates most field-installed wiring requirements, the electrical contractor must still complete the electrical connection for: (1) Power supply wiring to the starter, (2) Other unit control options present, and (3) Any field-supplied control devices.

### General Requirements

#### ▲ WARNING!

#### Hazardous Voltage!

**Use extreme caution when measurements, adjustments, or other service-related work is performed with power on. Failure to disconnect power before servicing could result in death or serious injury.**

#### ▲ WARNING

#### Rotating Parts!

**During installation, testing, servicing and troubleshooting of this product it may be necessary to measure the speed of rotating components. Have a qualified or licensed service individual who has been properly trained in handling exposed rotating components perform these tasks. Failure to follow all safety precautions when exposed to rotating components could result in death or serious injury.**

As you review this manual, along with the wiring instructions presented in this section, keep in mind that:

Typical field connection requirements for remote-mounted starters are shown at the end of the manual, and summarized in Table 1.

All field-installed wiring must conform to National Electric Code (NEC) guidelines, as well as to any applicable state and local codes. Be sure to satisfy proper equipment grounding requirements per NEC.

All field-installed wiring must be checked for proper terminations, and for possible shorts or grounds.

**Note:** The typical customer connection diagrams shown in this manual are representative of standard CVHE, CVHF and CVHG units, and are provided only for general reference. Always refer to the actual wiring diagrams that shipped with the chiller for specific as built electrical schematic and connection information.

Do not modify or cut enclosure to provide electrical access. Removable panels have been provided for this purpose. Modify these panels only; away from enclosure. Refer to installation information shipped with the starter or submittal drawings.

#### CAUTION

**TO AVOID DAMAGE TO STARTER COMPONENTS, remove debris inside the starter panel. Failure to do so may cause an electrical short that seriously damages the starter components.**

# Electrical Information

## Trane Supplied Remote Starter

**Table 1 – CVHE, CVHF, and CVHG Standard Field Wiring Requirements**

<b>Power Supply wiring (to Starter Panel)</b>	<b>Starter Panel Terminals</b>		
3-Phase Line Voltage: Terminal Block (2TB3 or 2X3)	2X3-L1, L2, L3, and GROUND	All wiring to be in accordance with National Electrical Code and any local codes.	
3-Phase Line Voltage: Circuit Breaker	2Q1-L1,L2,L3, and GROUND		
Remote Starter to Chiller Motor Junction Box	T1 through T6		
<b>Starter to UCP 120VAC control wiring</b>	<b>Starter Panel Terminals</b>	<b>Unit Control Panel Terminations</b>	
120VAC Power Supply	2X1-1-1, 2X1-15 2X1-20(Ground)	1X1-1, 1X1-12 1X1-18 (Ground)	#8 gauge minimum 40 amps circuit
High Pressure Cutout	2X1-4, 2X1-6	1X1-4, 1X1-3	14 ga.
Oil Pump Interlock	2X1-7, 2X1-8	1A7-J2-4, 1A7-J2-2	14 ga.
<b>Low Voltage Circuits (less than 30VAC)</b>	<b>Starter Panel Terminals</b>	<b>Unit Control Panel Terminations</b>	
Standard Circuits			
Inter Processor Communications (IPC) Remote Mounted	2A1- J3-3 to 4, or 2X1-12 to 13 if present (do not ground shield at starter )	1A1 –J5 1-2  Shield ground at 1X1- 22(GND) only.	2 wire w/ ground Comm link.

**Standard Field Power wiring:**

Note: All wiring to be in accordance with National Electrical Code and any local codes.

**Reference Field connection diagram 2309-4935 in this manual**



# Electrical Information

# Customer Supplied Remote Starter

**Table 2 – CVHE, CVHF, and CVHG Standard Field Wiring Requirements**

<b>Power Supply wiring (to Starter Panel)</b>	<b>Starter Panel Terminals</b>		
<b>Starter by others</b>	<b>See "Starter by others" schematic</b>		All wiring to be in accordance with National Electrical Code and any local codes.
<b>Power wiring:</b> 3-Phase Power Supply Starter and Motor Junction Box Interconnection (Remote starter only) Starter provided by others:			
<b>Starter to UCP 120VAC control wiring</b>	<b>Starter Panel Terminals</b>	<b>Unit Control Panel Terminations</b>	
120VAC Power Supply	See "Starter by others" schematic 5X1-1, 5X1-2 5X1-22 (Ground)	1X1-1, 1X1-12 1X1-18	#8 gauge minimum 40 amps circuit
Power from UCP 1Q1	5X1-3	1X1-3, 1A23-J6-3	14 ga.
Interlock Relay signal	5X1-4	1A23-J10-1	14 ga.
Start contactor signal	5X1-5	1A23-J8-1	14 ga.
Oil Pump Interlock	5X1-7, 5X1-8	1A7-J2-4, 1A7-J2-2	14 ga.
Run Contactor signal	5X1-10	1A23-J6-12	14 ga.
Transition Complete	5X1-14	1A23-J12-2	14 ga.
<b>Low Voltage Circuits (less than 30VAC)</b>	<b>Starter Panel Terminals</b>	<b>Unit Control Panel Terminations</b>	
<b>Standard Circuits</b>			
Current Transformers* (see table next page)	5CT4- wht, blk 5CT5- wht, blk 5CT6- wht, blk	1A23-J7-1,2 1A23-J7-3,4, 1A23-J7-5,6,	Note: Phasing must be maintained
Potential Transformers	5T17-236,237 5T18-238,239 5T19-240,241	1A23 -J5-1,2, 1A23 -J5-3,4, 1A23 -J5-5,6	Note: Phasing must be maintained

**Starter Supplied by Others -Standard Field Power wiring:**

Note: All wiring to be in accordance with National Electrical Code and any local codes.

**Reference Field Connection Customer Supplied Starter diagram 2309-4936 in this manual**

# Electrical Information

# Customer Supplied Remote Starter

**Table 3 – Current Transformer and Potential Transformer Wire Sizing Tables for Customer Supplied Starter to Chiller Unit Control Panel Starter Module 1A23.**

The maximum recommended wire length for secondary CT leads in a dual CT system are:

Wire AWG (mm <sup>2</sup> )	Maximum Wire Length Secondary CT Leads	
	Feet	Meters
8 (10)	1362.8	415.5
10 (6)	856.9	261.2
12 (4)	538.9	164.3
14 (2.5)	338.9	103.3
16 (1.5)	213.1	65.0
17 (1)	169.1	51.5
18 (0.75)	134.1	40.9
20 (0.5)	84.3	25.7

Note:

1. Wire lengths are for copper conductors only.
2. Wire lengths are total "one way" distance that the CT can be from the Starter module.

The maximum recommended total wire length for PT's in a single PT system:

Wire Gauge	Max lead length (ft)	Max lead length (m)
8	5339	1627
10	3357	1023
12	2112	643
14	1328	404
16	835	254
17	662	201
18	525	160
20	330	100
21	262	79
22	207	63

The maximum recommended total wire length (to and from) for PT leads in a dual PT system are:

Wire Gauge	Max Wire Length Primary (ft)	Max Wire Length Primary (m)	Max Wire Length Secondary (ft)	Max Wire Length Secondary (m)
8	3061	933	711	217
10	1924	586	447	136
12	1211	369	281	85
14	761	232	177	53
16	478	145	111	33
17	379	115	88	26
18	301	91	70	21
20	189	57	44	13
21	150	45	34	10
22	119	36	27	8

Note: These wire lengths are for copper conductors only

Note: The above lengths are maximum round trip wire lengths. The maximum distance the PT can be located from the Starter module is 1/2 of the listed value.

# Electrical Information

## Power Supply

### Power Supply Wiring

To assure that power supply wiring to the starter panel is properly installed and connected, review and follow the guidelines outlined below.

#### 3-Phase Power Source

1. Verify that the starter nameplate ratings are compatible with the power supply characteristics and with the electrical data on the unit nameplate.
2. If the starter enclosure must be cut to provide electrical access, exercise care to prevent debris from falling inside the enclosure. If the starter cabinet has a removable panel, be sure to remove the panel from the unit before drilling holes.

#### CAUTION

**TO AVOID DAMAGE TO STARTER COMPONENTS, remove debris inside the starter panel. Failure to do so may cause an electrical short that seriously damages the starter components.**

3. Use copper conductors to connect the 3-phase power supply to the remote or unit-mounted starter panel.

#### CAUTION

**USE ONLY COPPER CONDUCTORS FOR TERMINAL CONNECTIONS.**

**Failure to do so may cause corrosion or overheating, and starter damage.**

4. Size the power supply wiring in accordance with the Minimum Circuit Ampacity (MCA) shown on the unit nameplate.  
( $MCA = (RLA \times 1.25) + \text{Control Power Load}$ )
5. Make sure that the incoming power wiring is properly phased; each power supply conduit run to the starter must carry the correct number of conductors to ensure equal phase representation. See Figure 1.

6. As you install the power supply conduit, make sure that this position does not interfere with the serviceability of any of the unit components, nor with structural members and equipment.

Also, assure that the conduit is long enough to simplify any servicing that may be necessary in the future (e.g., starter removal).

**Note:** Use flexible conduit to enhance serviceability and minimize vibration transmission.

#### Circuit Breakers and Fusible Disconnects

Size the circuit breaker or fuse disconnect in compliance with NEC or local guidelines.

*Figure 1 – Proper Phasing for Starter Power Supply Wiring and Conduit Loading*

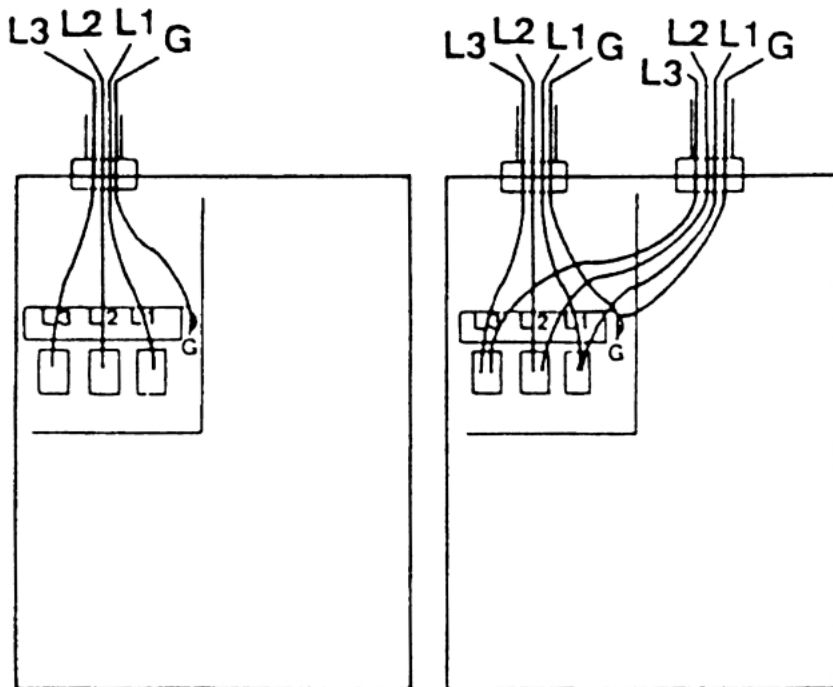

# Electrical Information

## PFCC

### Optional PFCCs

Power factor correction capacitors (PFCCs) are designed to provide power factor correction for the compressor motor. They are available as an option.

**Note:** Remember that the PFCC nameplate voltage rating must be greater than or equal to the compressor voltage rating stamped on the unit nameplate. See Table 2 to determine what PFCC is appropriate for each compressor voltage application.

### CAUTION

**PFCCS MUST BE WIRED INTO THE STARTER CORRECTLY! Failure to do so may cause misapplication of these capacitors and result in a loss of motor overload protection and subsequently cause motor damage.**

**Table 3 – PFCC Design Voltage Sizing per Compressor Voltage Application**

PFCC Design Voltage	Compressor Motor Rating (See Unit Nameplate)
240V/60 Hz	208V/60 Hz
480V/60 Hz	380V/60 Hz 440V/60 Hz 460V/60 Hz 480V/60 Hz
600V/60 Hz	575V/60 Hz 600V/60 Hz
2400V/60 Hz	2300V/60 Hz 2400V/60 Hz
PFCC Rating	Compressor Motor Rating (See Unit Nameplate)
480V/50 Hz	346V/50 Hz 380V/50 Hz 400V/50 Hz 415V/50 Hz
4160V/60 Hz	3300V/60 Hz 4160V/60 Hz

**Figure 2 – PFCC Leads Routed through Overload Current Transformer**

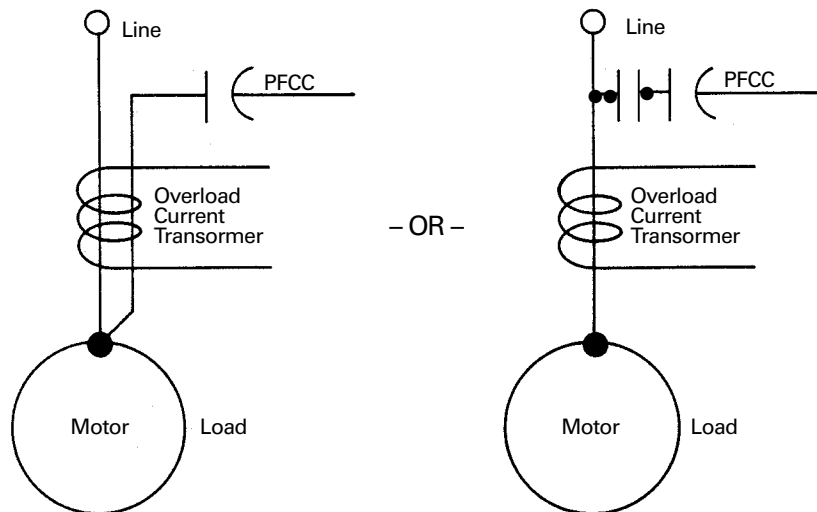

**Note:** See the attached wiring diagram for more detail.

# Electrical Information

# Unit Mounted Starter

## Interconnecting Wiring

Typical equipment room conduit layouts with and without unit-mounted starters are shown in Figures 3 and 4, respectively.

## IMPORTANT

Keep in mind that the interconnecting wiring between the starter panel, compressor and UCP control panel is factory-installed with unit-mounted starters but must be field-installed when a remote-mounted starter is used.

*Figure 3 – Typical Equipment Room Layout with Unit-Mounted, Wye-Delta*

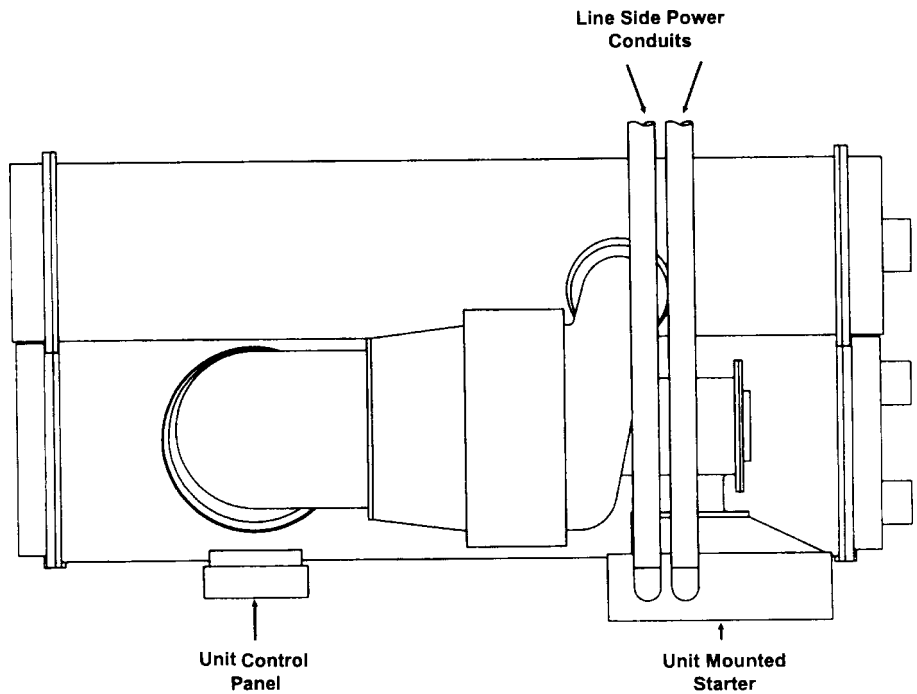

**Note:**  
See Starter submittal drawing for location of incoming wiring to the starter.

# Electrical Information

## Remote Starter

**Figure 4 – Typical Equipment Room Layout with Remote-Mounted Wye-Delta Starter**

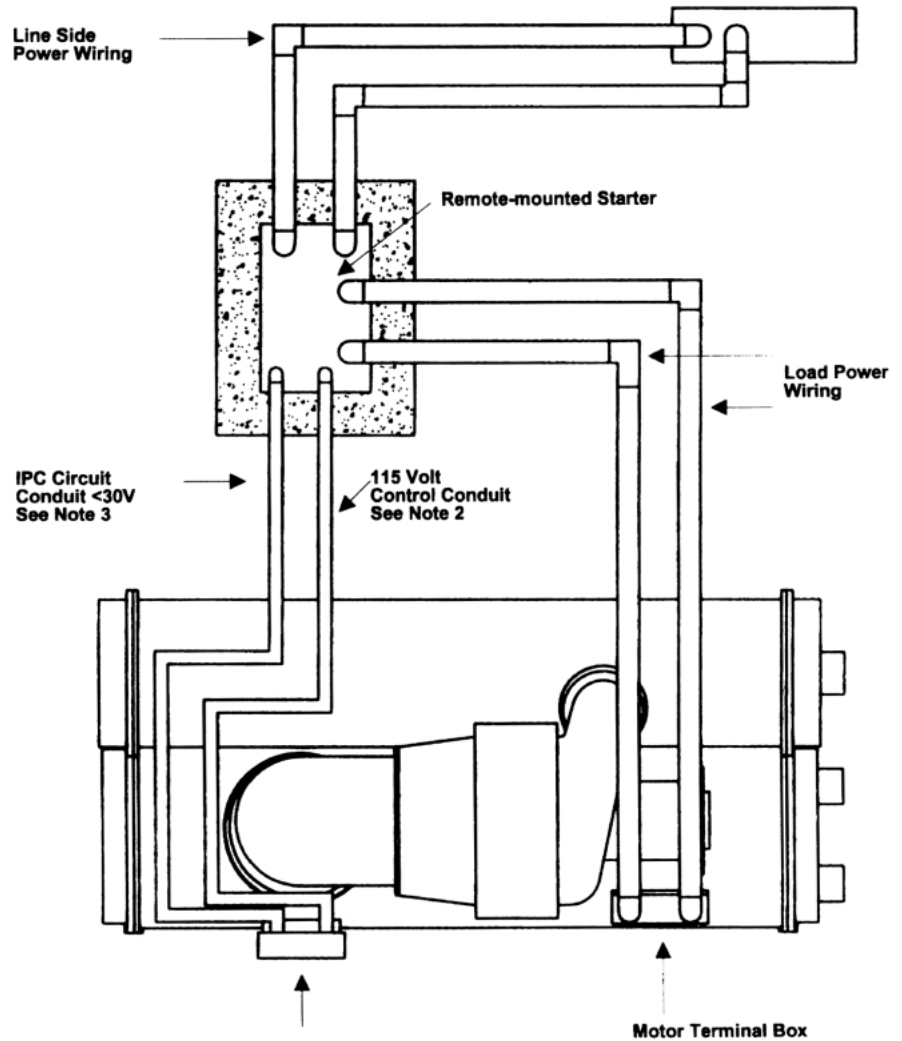

**Notes:**

1. Refer to the unit field connection diagram for approximate UCP knockout locations.
2. 115-volt conduit must enter the higher than 30 Vdc Class I portion of the unit control panel.
3. IPC circuit conduit must enter the Low Voltage Class II portion of the UCP.
4. See starter submittal drawing for location of incoming wiring to the starter.



# Electrical Information

## Remote Starter

### Starter to Motor (Remote-Mounted Starters Only)

#### Ground Wire Terminal Lugs

Ground wire lugs are provided in the motor terminal box and in the starter panel.

#### Terminal Clamps

Terminal clamps are supplied with the motor terminals to accommodate either bus bars or standard motor terminal wire lugs. Terminal clamps provide additional surface area to minimize the possibility of improper electrical connections.

#### Wire Terminal Lugs

Wire terminal lugs must be field-supplied.

1. Use field-provided crimp-type wire terminal lugs properly sized for the application.

**Note:** Wire size ranges for the starter line and load-side lugs are listed on the starter submittal drawings supplied by the starter manufacturer or Trane. Carefully review the submitted wire lug sizes for compatibility with the conductor sizes specified by the electrical engineer or contractor.

2. A terminal clamp with a 3/8" bolt is provided on each motor terminal stud; use the factor-supplied Belleville washers on the wire lug connections.

Figure 5 illustrates the juncture between a motor terminal stud and terminal clamp.

3. Tighten each bolt to 24 foot-pounds.
4. Install but do not connect the power leads between the starter and compressor motor. (These connections will be completed under supervision of a qualified Trane service engineer after the prestart inspection).

### CAUTION

**ENSURE THE POWER SUPPLY WIRING AND OUTPUT TO MOTOR WIRING ARE CONNECTED TO THE PROPER TERMINALS. Failure to do so will cause catastrophic failure of the starter and, or motor**

#### Bus Bars

Install the bus bars between the motor terminals when a low-voltage "across-the-line", "primary reactor/resistor," "auto transformer" or customer-supplied solid-state, or customer-supplied AFD.

Be sure to bus motor terminal T1 to T6, T2 to T4, and T3 to T5.

**Note:** Bus bars are not needed in high-voltage applications since only 3 terminals are used in the motor and starter.

### Starter to UCP (Remote-Mounted Starters Only)

Electrical connections required between the remote-mounted starter and the unit control panel are shown in an example of a point-to-point starter-to-UCP connection diagram as shown at the end of the manual.

**Note:** Install control voltage conduit into control voltage section of chiller control panel and starter panel. Do not route with low voltage (30 volts) conduit wires.

When sizing and installing the electrical conductors for these circuits, follow the guidelines listed.

Unless otherwise specified use 14 ga. wire for 120 V control circuits.

# Electrical Information

## Remote Starter

### CAUTION

**Starter Component Damage.**  
Remove debris inside the starter panel. Failure to do so may cause an electrical short that seriously damages the starter components.

1. If the starter enclosure must be cut to provide electrical access, exercise care to prevent debris from falling inside the enclosure. Do not cut AFD enclosure.
2. Use only shielded twisted pair for the interprocessor communication (IPC) circuit between the starter and the UCP on remote mounted starters. Recommended wire is Beldon Type 8760, 18 AWG for runs up to 1000 feet.

Note: The polarity of the IPC wire pair is critical for proper operation.

3. Separate low-voltage (less than 30V) wiring from the 115V wiring by running each in its own conduit.
4. As you route the IPC circuit out of the starter enclosure, make sure that it is at least 6" from all wires carrying a higher voltage.

5. For UCP IPC shielded twisted pair wiring, the shield should be grounded on one end only at UCP at 1X1-G. The other end should be unterminated and taped back on the cable sheath to prevent any contact between shield and ground.

6. Oil Pump Interlock - All starters must provide an interlock (N.O.) contact with the chiller oil pump connected to the UCP at Terminals 1A7-2-4 and 1A7-J2-2 (14 ga.)

The purpose of this interlock is to power the oil pump on the chiller in the event that a starter failure, such as welded contacts, keeps the chiller motor running after the controller interrupts the run signal.

### CAUTION

**Electrical Noise.**  
Maintain at least 6 inches between low-voltage (<30V) and high voltage circuits. Failure to do so could result in electrical noise that may distort the signals carried by the low-voltage wiring, including the IPC.

# Electrical Information

## Motor Lugs

Figure 5 – Terminal Stud, Clamp and Lug Assembly

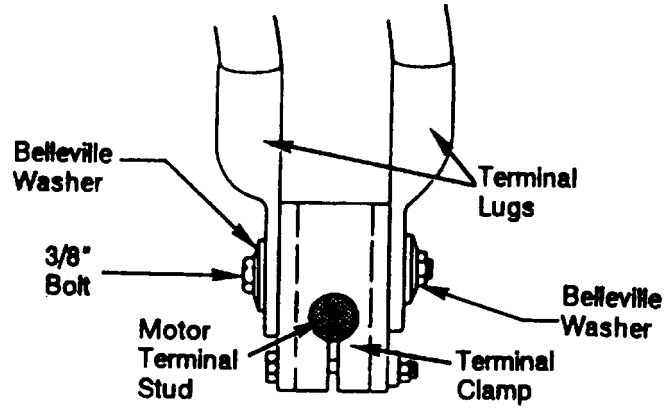

**Front View**

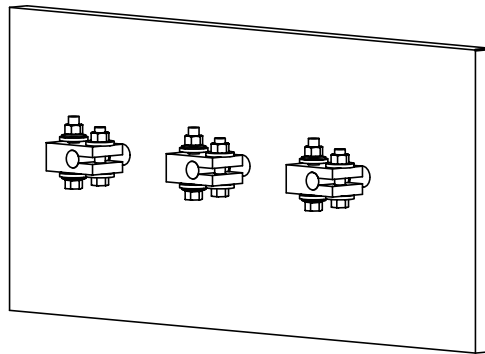

MID VOLTAGE  
RXL RATR RPIR CXL CATR CPIR

# Electrical Information

# Field Control Panel Signal Wiring

**Table 4**

<b>Standard Control Circuits: UCP Control Wiring (120 VAC)</b>	<b>Unit Control Terminations</b>	<b>Input or Output Type</b>	All wiring to be in accordance with National Electrical Code and any local codes. Contacts
Chilled Water Flow Proving Input	1X1-5 to 1A6-J3-2	Binary Input	Normally Open, closure with flow
Condenser Water Flow Proving Input	1X1-6 to 1A6-J2-2	Binary Input	Normally Open, closure with flow
Chilled Water Pump Relay Output	1A5-J2- 4 to 6	Binary Output	Normally Open
Condenser Water Pump Relay Output	1A5-J2-1 to 3	Binary Output	Normally Open
<b>Optional Control Circuits (120 VAC)</b>			
Alarm Relay MAR (Non-Latching) Output	1A8-J2-1 to 3	Binary Output	Normally Open
Limit Warning Relay Output	1A8-J2-4 to 6	Binary Output	Normally Open
Alarm Relay MMR (Latching) Output	1A8-J2-7 to 9	Binary Output	Normally Open
Compressor Running Relay Output	1A8-J2-10 to 12	Binary Output	Normally Open
Maximum Capacity Relay Output	1A9-J2-1 to 3	Binary Output	Normally Open
Head Relief Request Relay Output	1A9-J2-4 to 6	Binary Output	Normally Open
Purge Alarm Relay Output	1A9-J2-7 to 9	Binary Output	Normally Open
Ice Making Relay Output	1A10-J2-4 to 6	Binary Output	Normally Open
Free Cooling Relay Output	1A11-J2-4 to 6	Binary Output	Normally Open
<b>Standard Low Voltage Circuits (less than 30VAC)</b>			
<b>Low Voltage Circuits</b>	<b>Unit Control Panel Terminations</b>	<b>Input or Output Type</b>	
External Auto Stop Input	1A13-J2-1 to 2	Binary Input	Closure required for normal operation
Emergency Stop Input	1A13-J2-3 to 4	Binary Input	Closure required for normal operation
<b>Optional Low Voltage Circuits</b>			
External Base Loading Enable Input	1A18-J2-1 to 2	Binary Input	Normally Open
External Hot Water Control Enable Input	1A18-J2-3 to 4	Binary Input	Normally Open
External Ice Machine Control Enable Input	1A19-J2-1 to 2	Binary Input	Normally Open
Free Cooling Input Enable Input	1A20-J2-1 to 2	Binary Input	Normally Open
RLA Compressor Output	1A15-J2-1 to 3	Analog Output	2-10 vdc
External Condenser Pressure Output	1A15-J2-4 to 6	Analog Output	2-10 vdc
External Current Limit Setpoint Input	1A16-J2-2 to 3	Analog Input	2-10 vdc, or 4-20 mA
External Chilled Water Setpoint	1A16-J2-5 to 6	Analog Input	2-10 vdc, or 4-20 mA
External Base Load Setpoint Signal	1A17-J2-2 to 3	Analog Input	2-10 vdc, or 4-20 mA
Generic Refrigerant Monitor input	1A17-J2-4 to 6	Analog Input	2-10 vdc, or 4-20 mA
Outdoor Air Temperature sensor	IPC bus Connection and sensor	Communication and sensor.	
Tracer Comm Interface	1A14-J2-1(+) to 2(-) 1A14-J2-3(+) to 4(-)	Communication to Tracer	

# Electrical Information

# Field Control Panel Signal Wiring

**Figure 6**

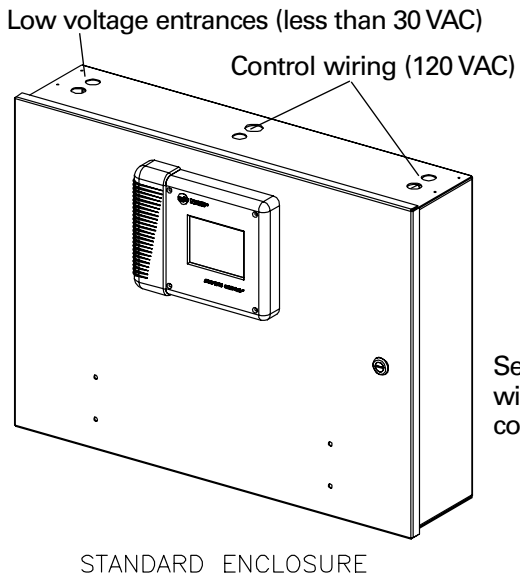

**Note:** UCP control wiring (120 VAC) must not be routed with low voltage circuits (less than 30 VAC). Conduit access holes are furnished in the top of the unit control panel. Use the left holes for low voltage wiring, and use center and right hand holes for control (120 VAC) wiring.

**\*Note:** The wire is retained in the clamp by the force of the spring which pushes the wire against the connecting bar. Use care to ensure full insertion of screwdriver into terminal block wire release mechanism. Proper tool engagement is required to release the tension for wire insertion.

Separate low voltage field wiring from 120 VAC control wiring

# Electrical Information

# Field Control Panel Signal Wiring

## Control Panel Internally mounted devices

For visual identification Internal Control Panel mounted devices are identified by their respective schematic designation number. Control panel items are marked on the inner back panel in the control panel. Figure 7 illustrated below, identifies these devices. The Control

Panel Devices table corresponds to the same device designators (see right hand column). Optional controls are present when a specific optional controls package is specified, as listed in the second column. Optional controls packages are; OPST Operating Status, GBAS Generic Building Systems, EXOP Extended operation, CDRP

Condenser Pressure, TRMM Tracer communications, WPSR Water Flow Pressure sensing, FRCL Free Cooling, HGBP Hot Gas Bypass, and EPRO Enhanced Protection

Figure 20 illustrates the Control Panel Components Layout.

Modules 1A1, 1A3, 1A4, 1A5, 1A6, 1A7, and 1A13 are standard and present in all configurations. Other Modules vary depending on machine optional devices.

**Figure 7 - Control Panel Components Layout**

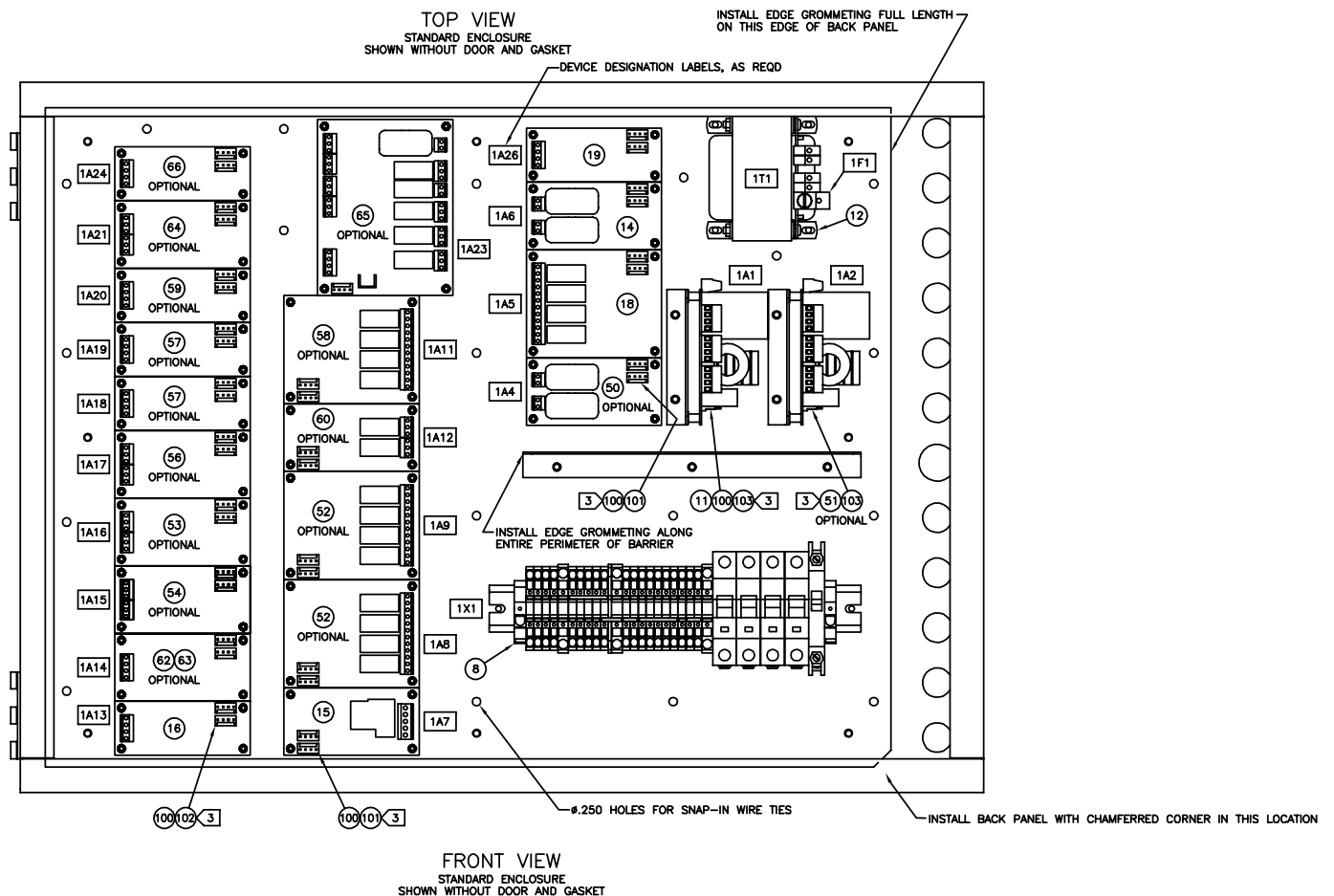

# Electrical Information

Figure 8 – Illustrates Communication/Control Network to Chiller Units with CH530

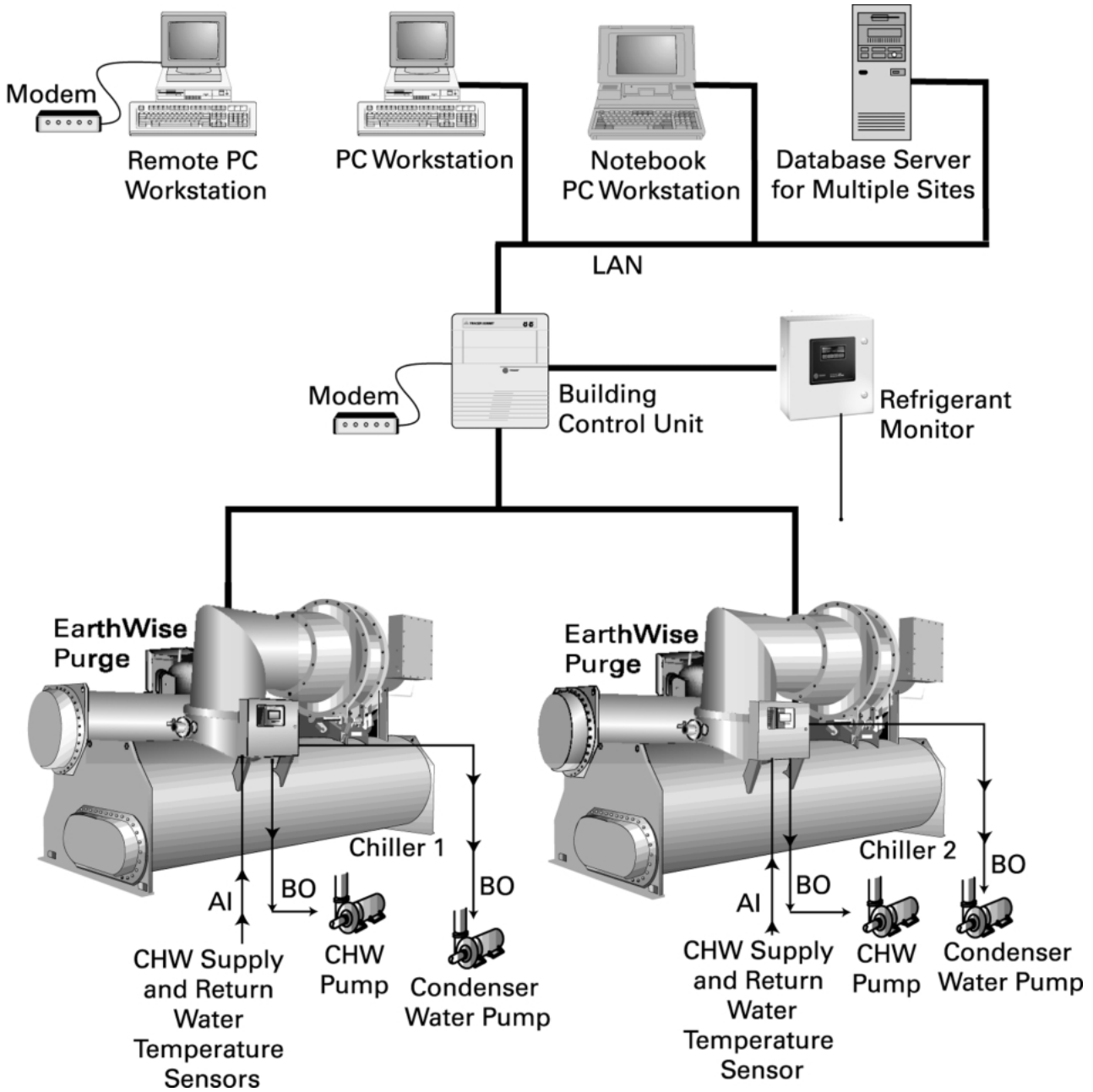

# Wiring Drawings

## Schematic Wiring Drawings

The following pages consist of typical wiring drawings for an CVHE, CVHF or CVHG chiller. However, please refer to the submittals and drawings that actually shipped with the unit.

Refer to the chiller operation and maintenance manual for an example of a typical sequence of operation for a Unit Mounted Wye-Delta Starter.

In the starter drawings, shown in this manual, all starter variables are the same in the Sequence of Operation except the Maximum Acceleration Time.

Table 5 provides a listing of included schematics, connection diagrams and field wiring drawings to follow.

Table 5 also shows variables of the Maximum Acceleration Time for all starter drawings in this manual.

**Table 5 – Wiring Addendum**

Type of Drawing	Drawing Number	Maximum Acceleration Time (seconds)	Page #
<b>Field Wiring Layout Drawings</b>			
Legend (Unit Mounted Wye-Delta Starter)	2309-4922-C	–	66
Unit Mounted Wye-Delta Starter	2309-4902-C	27	20-21
Unit Mounted Solid-State Starter	2309-4904-C	15	24-25
Unit Mounted Across-the-Line	2309-4906-C	6	28-29
Unit Mounted Adaptive Frequency Drive	2309-4912-D	30	34-35
Remote Wye-Delta Starter	2309-4903-C	27	22-23
Remote Mounted Solid-State Starter	2309-4905-C	15	26-27
Remote Across-the-Line Starter	2309-4909-D	6	30-31
Remote Primary Reactor Starter	2309-4910-D	11	32-33
Remote Auto Transformer Starter	2309-4911-D	11	34-35
Customer Supplied Wye-Delta Starter	2309-4913-D	27	38-39
Customer Supplied Primary Reactor and Auto Transformer Starter	2309-4914-D	11	40-41
Customer Supplied Across-the-Line Starter	2309-4915-D	6	42-43
Customer Supplied Solid-State Starter	2309-4916-D	20	44-45
Purge Schematic	2309-4917-C	–	46-47
Unit Controls Schematic	2309-4919-D	–	48-49
System Controls Schematic	2309-4920-D	–	50-51
Options Schematic	2309-4921-C	–	52-53
<b>Connection Diagrams</b>			
Standard Connection Diagram Panel with Options	2309-4923-D	–	54-55
Field Connection Trane Starter	2309-4935-D	–	56-57
Customer Supplied Starter	2309-4936-D	–	58-59
Unit Wiring – Standard	2309-4937-D	–	60-61
Unit Wiring – Optional	2309-4938-E	–	62-63
Purge Control Panel (Unit Mounted)	2309-4939-C	–	64-65

**Note:** These are typical drawings only. Refer to specific as-built schematics for actual unit drawings which represent the unit wiring as shipped.



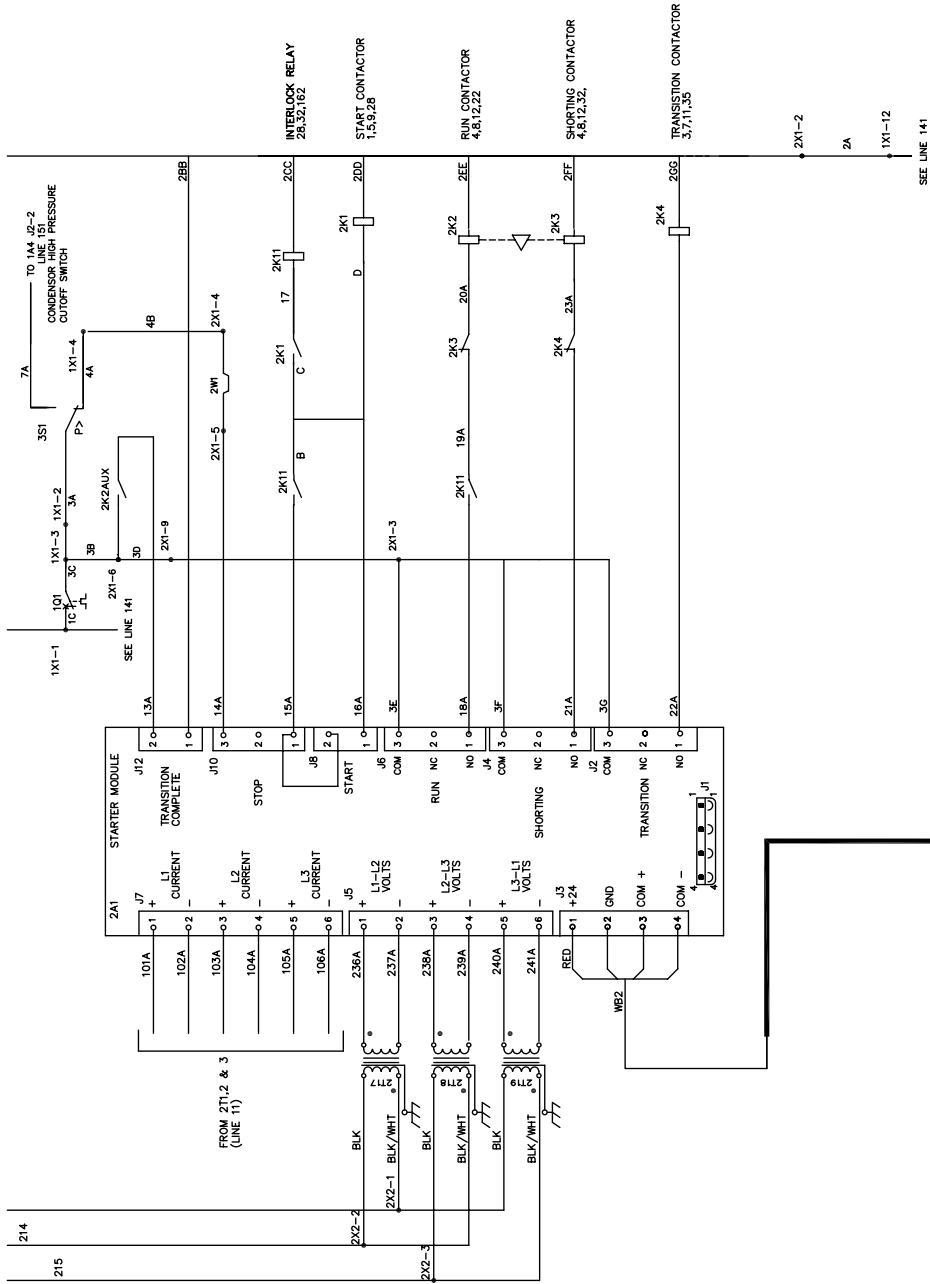

**⚠ WARNING**  
 HAZARDOUS VOLTAGE!  
 DISCONNECT ALL ELECTRIC POWER BEFORE SERVICING.  
 FAILURE TO DISCONNECT POWER BEFORE SERVICING MAY CAUSE SEVERE PERSONAL INJURY OR DEATH.

**⚠ AVERTISSEMENT**  
 VOLTAGE HASARDEUX!  
 DECONNECTEZ TOUTES LES SOURCES D'ÉLECTRICITÉ AVANT D'EFFECTUER LE TRAVAIL DE RÉPARATION. L'ÉLECTRICITÉ AVANT D'EFFECTUER LE TRAVAIL DE RÉPARATION PEUT CAUSER DE GRAVES BLESSURES CORPORELLES SEVERES OU LA MORT.

**⚠ CAUTION**  
 USE COPPER CONDUCTORS ONLY. USE TERMINALS ARE NOT DESIGNED FOR OTHER TYPES OF CONDUCTORS. FAILURE TO DO SO MAY CAUSE DAMAGE TO THE EQUIPMENT.

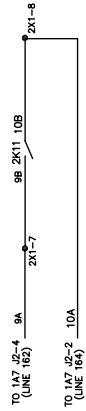

THIS DRAWING IS PROPRIETARY AND SHALL NOT BE COPIED OR ITS CONTENTS DISCLOSED TO OUTSIDE PARTIES WITHOUT THE WRITTEN CONSENT OF THE TRANE COMPANY.

IPC BUS



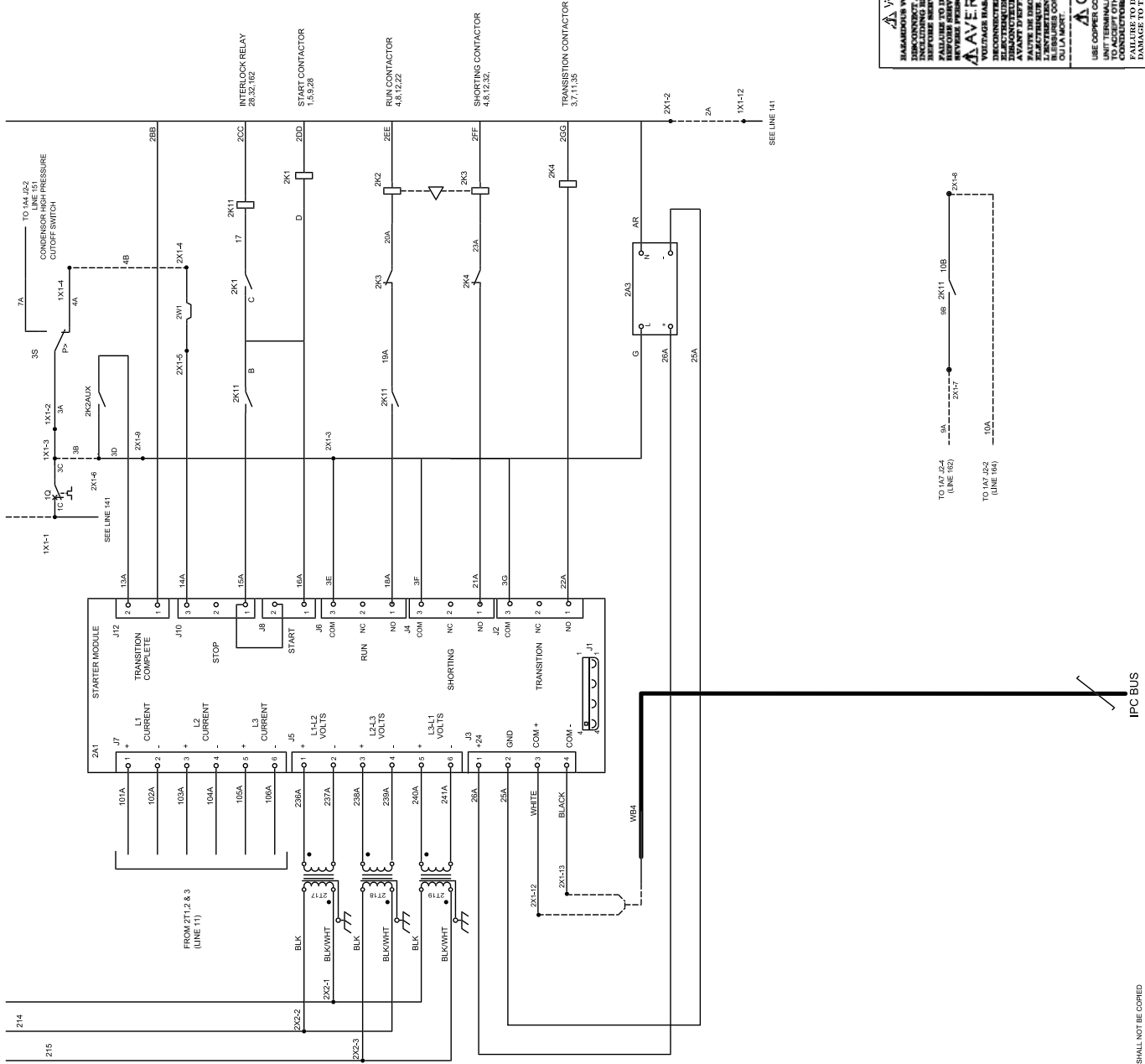

**WARNING**  
 HAZARDOUS VOLTAGE  
 THIS DRAWING IS THE PROPERTY OF THE TRANE COMPANY AND SHALL NOT BE COPIED OR ITS CONTENTS DISCLOSED TO OUTSIDE PARTIES WITHOUT THE WRITTEN CONSENT OF THE TRANE COMPANY.

**AVERTISSEMENT**  
 DANGERS DE HAUTE TENSION  
 CE SCHÉMA EST LA PROPRIÉTÉ DE LA SOCIÉTÉ TRANE ET NE DOIT PAS ÊTRE REPRODUIT NI COMMUNIQUÉ À DES TIERS SANS LE CONSENTEMENT ÉCRIT DE LA SOCIÉTÉ TRANE.

**CAUTION**  
 USE COPPER CONDUCTORS ONLY  
 UNIT TERMINALS ARE NOT DESIGNED FOR ALUMINUM TYPES OF CONDUCTIONS.  
 FAILURE TO DO SO MAY CAUSE DAMAGE TO THE EQUIPMENT.

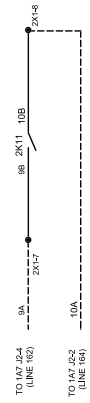

THIS DRAWING IS THE PROPERTY OF THE TRANE COMPANY AND SHALL NOT BE COPIED OR ITS CONTENTS DISCLOSED TO OUTSIDE PARTIES WITHOUT THE WRITTEN CONSENT OF THE TRANE COMPANY.



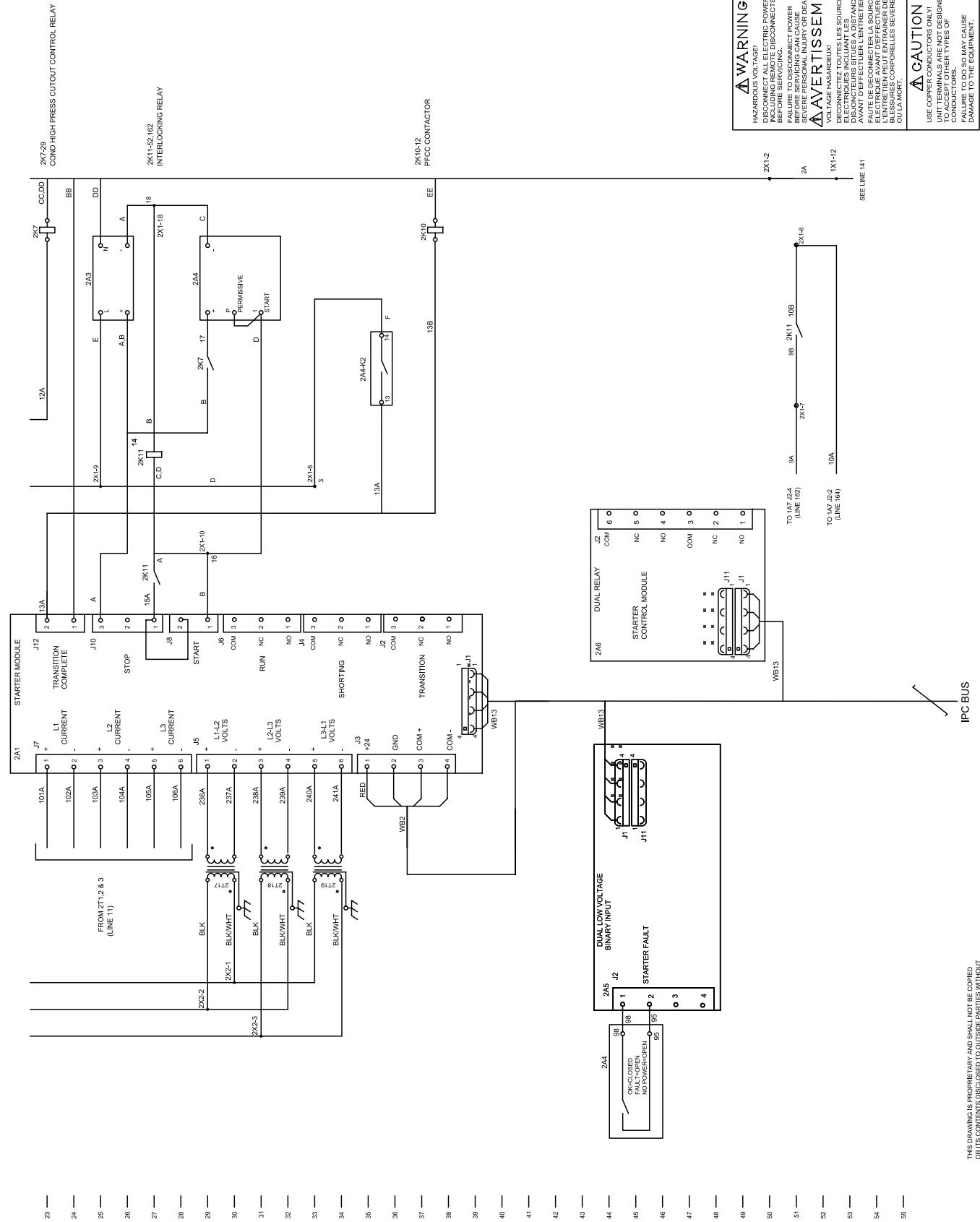

**WARNING**  
 HAZARDOUS VOLTAGE!  
 DISCONNECT ALL ELECTRICAL SOURCES  
 INCLUDING REMOTE DISCONNECTS  
 BEFORE SERVICING.  
 FAILURE TO DISCONNECT ALL SOURCES  
 BEFORE SERVICING CAN CAUSE  
 SEVERE PERSONAL INJURY OR DEATH.

**AVERTISSEMENT**  
 VOLTAGE HAZARDEUX!  
 DECONNECTEZ TOUTES LES SOURCES  
 Y COMPRIS LES DISCONNECTS LOUAGES  
 DISJONCTEURS SITUÉS A DISTANCE  
 AVANT D'EFFECTUER L'ENTRETIEN.  
 L'ÉCHEC À DÉCONNECTER TOUTES LES  
 SOURCES ÉLECTRIQUES AVANT D'EFFECTUER  
 L'ENTRETIEN PEUT ENTRAINER DES  
 BLESSURES PERSONNELLES SÈVES  
 OU LA MORT.

**CAUTION**  
 USE COPPER CONDUCTORS ONLY!  
 ALL WIRING MUST BE DESIGNED  
 TO ACCEPT OTHER TYPES OF  
 CONDUCTORS.  
 FAILURE TO DO SO CAN CAUSE  
 DAMAGE TO THE EQUIPMENT.

THIS DRAWING IS PROPRIETARY AND SHALL NOT BE COPIED  
 OR ITS CONTENTS DISCLOSED TO OUTSIDE PARTIES WITHOUT  
 THE WRITTEN CONSENT OF THE TRANE COMPANY

# 2309-4905C

## CH 530 SCHEMATIC WIRING CVHE, CVHF, CVHG REMOTE MOUNTED SOLID STATE STARTER

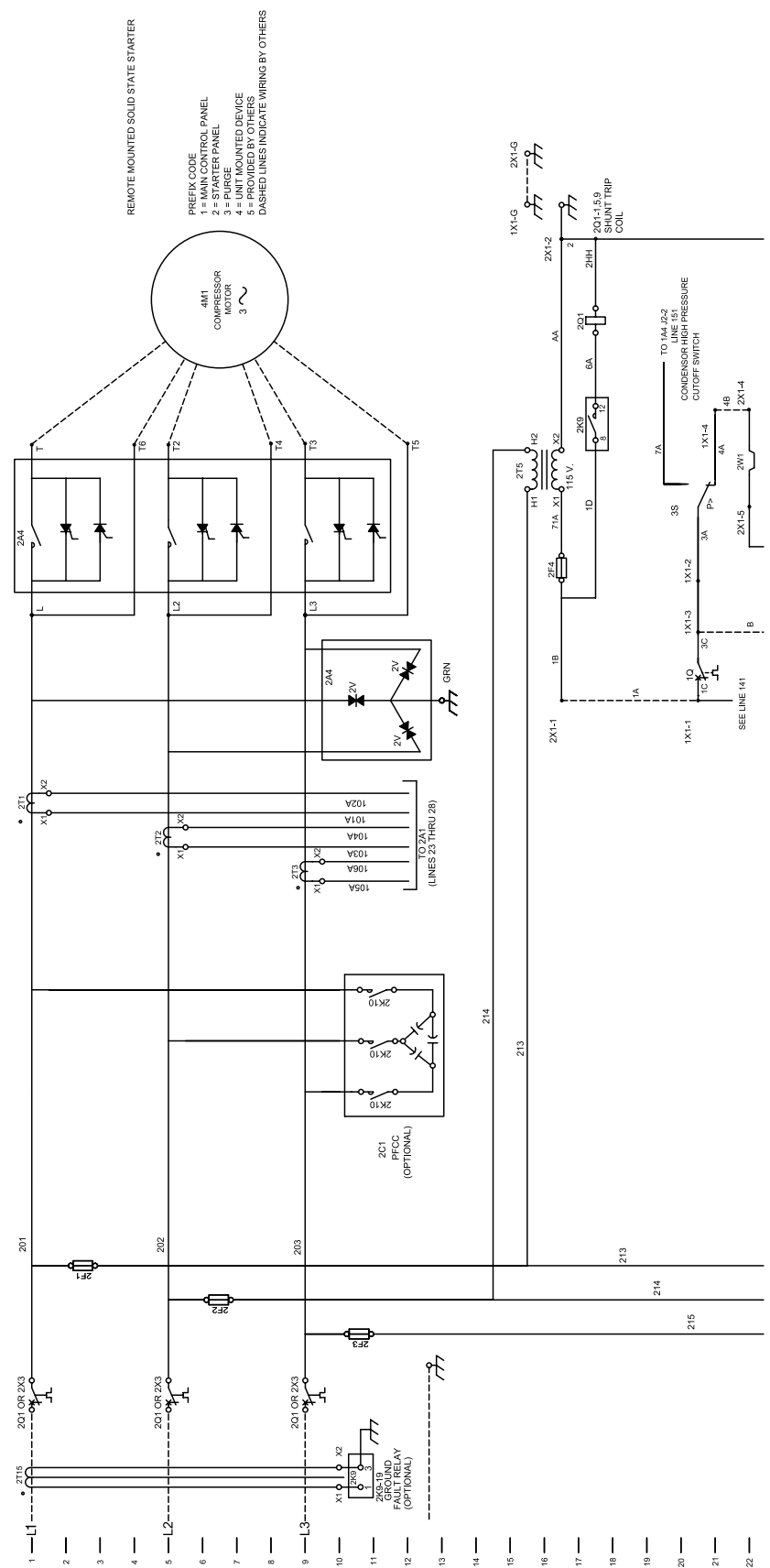

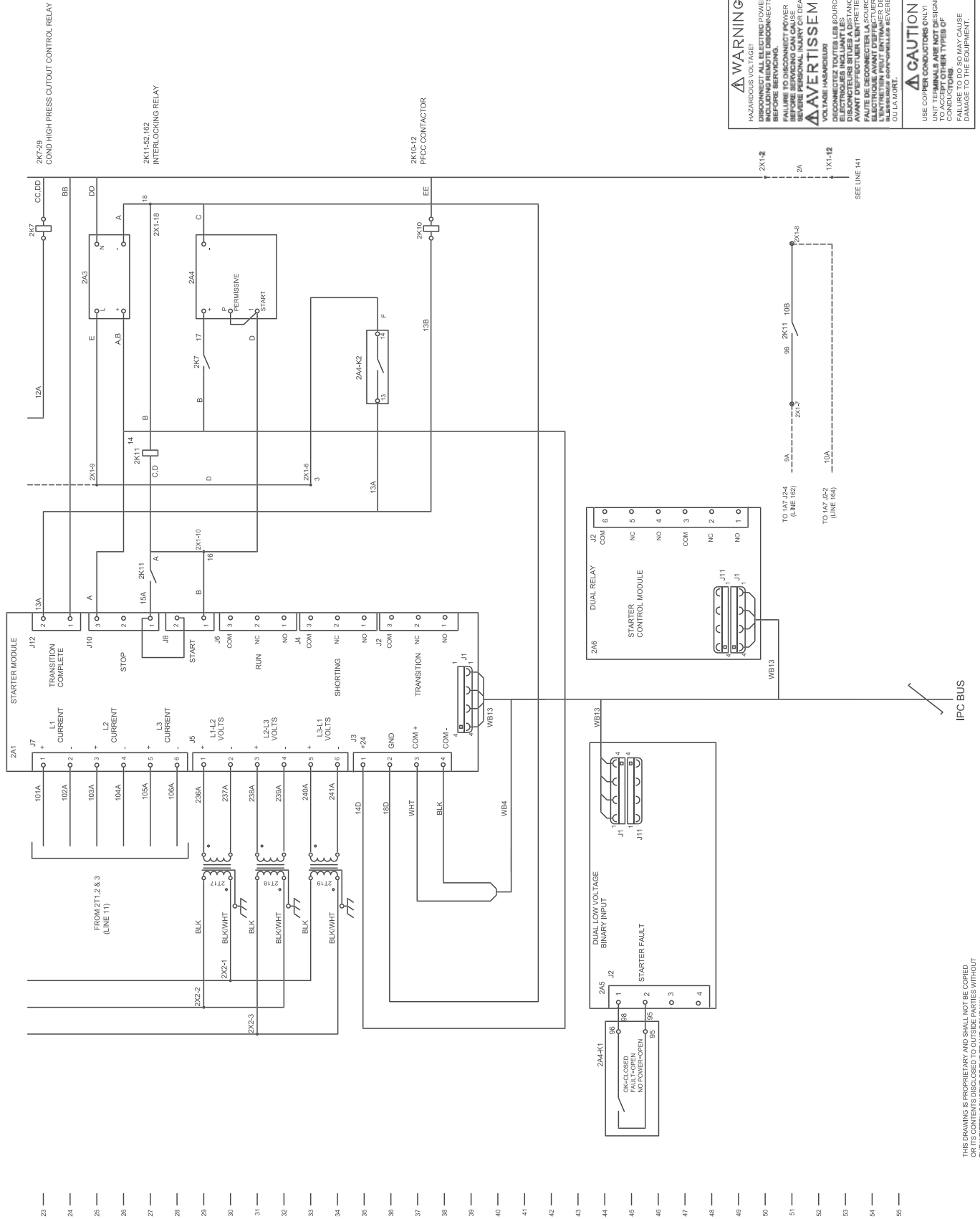

2K7-29  
COND HIGH PRESS CUTOFF CONTROL RELAY

2K11-52,162  
INTERLOCKING RELAY

2K10-12  
PFCC CONTACTOR

**WARNING**  
HAZARDOUS VOLTAGE!  
DISCONNECT ALL ELECTRICAL POWER  
BEFORE SERVICING.  
FAILURE TO DISCONNECT POWER  
BEFORE PERSONAL INJURY OR DEATH.  
VOLAGE HAZARDEUSE!  
DECONNECTEZ TOUTES LES SOURCES  
ELECTRIQUES INCLUANT LES  
AVANT D'EFFECTUER L'ENTRETIEN.  
FAUTE DE DECONNECTER LA SOURCE  
ELECTRIQUE PEUT ENTRAINER DES  
BLESSES CORPORELLES SEVERES  
OU LA MORT.

**CAUTION**  
USE COPPER CONDUCTORS ONLY!  
UNIT TERMINALS ARE NOT DESIGNED  
FOR ALUMINUM WIRE TYPES OF  
CONDUCTORS.  
FAILURE TO DO SO MAY CAUSE  
DAMAGE TO THE EQUIPMENT.

THIS DRAWING IS PROPRIETARY AND SHALL NOT BE COPIED,  
OR ITS CONTENTS DISCLOSED TO OUTSIDE PARTIES WITHOUT  
THE WRITTEN CONSENT OF THE TRANE COMPANY



23  
24  
25  
26  
27  
28  
29  
30  
31  
32  
33  
34  
35  
36  
37  
38  
39  
40  
41  
42  
43  
44  
45  
46  
47  
48  
49  
50  
51  
52  
53  
54  
55

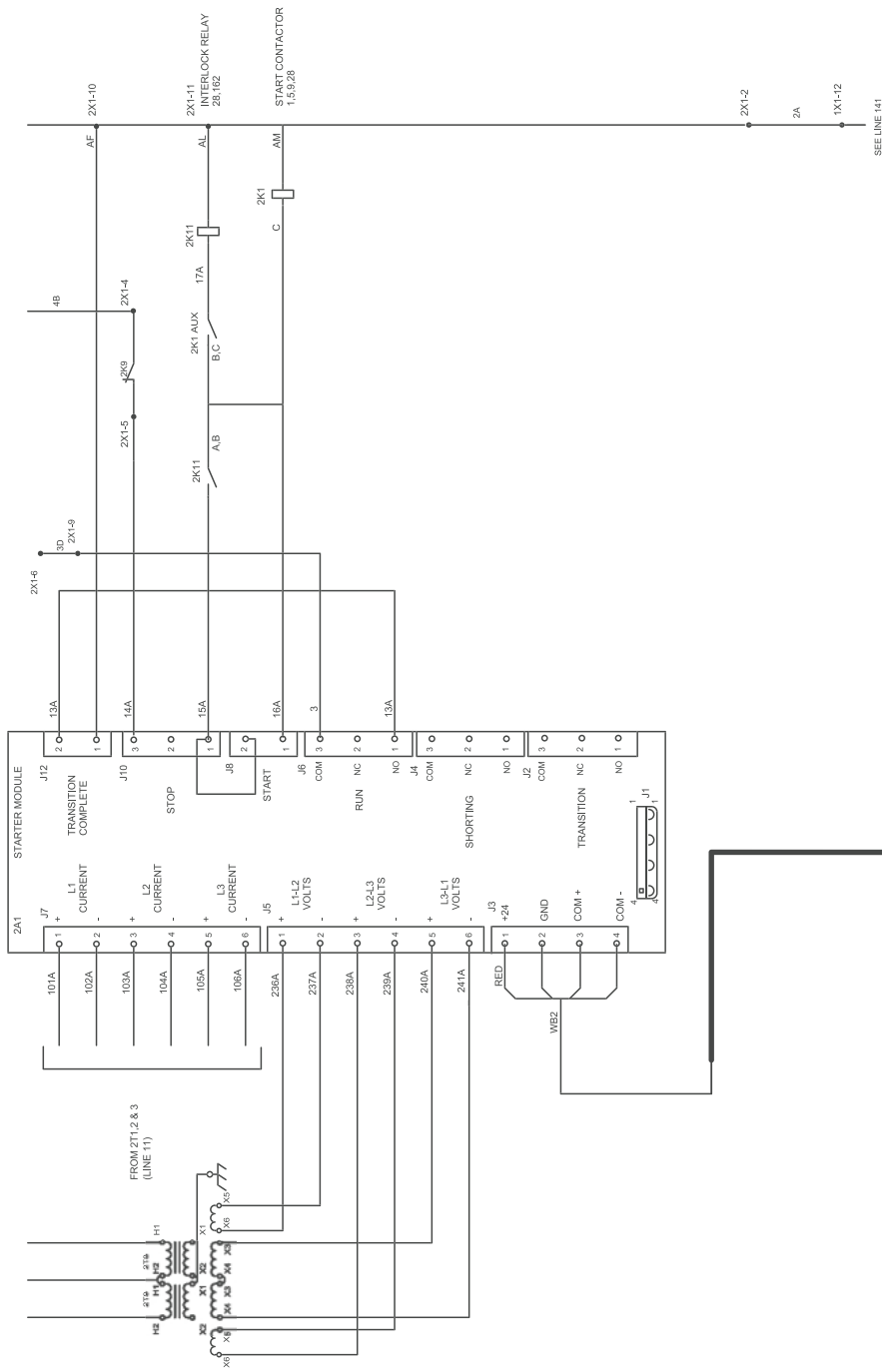

**WARNING**  
HAZARDOUS VOLTAGE!  
DISCONNECT ALL ELECTRICAL POWER  
BEFORE SERVICING.  
FAILURE TO DISCONNECT POWER  
BEFORE SERVICING MAY CAUSE DEATH,  
SERIOUS PERSONAL INJURY OR DEATH.

**AVERTISSEMENT**  
DÉCONNECTEZ TOUTES LES SOURCES  
D'ÉLECTRICITÉ INCLUANT LES  
CONDENSATEURS AVANT DE FAIRE  
AVANT DÉFECTUEUX LE MONTAGE.  
ÉLECTRIQUE AVANT D'ÉFFECTUER LES  
TRAVAUX DE RÉPARATION. LE NON  
RESPECT DE CE PROCÉDURE PEUT  
CAUSER LA MORT.

**CAUTION**  
USE COPPER CONDUCTORS ONLY!  
UNIT TERMINALS ARE NOT DESIGNED  
FOR ALUMINUM. CONTACTS OF  
FAILURE TO DO SO MAY CAUSE  
DAMAGE TO THE EQUIPMENT.

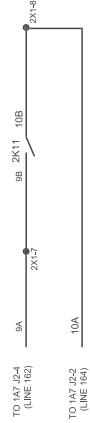

IPC BUS

THIS DRAWING IS PROPRIETARY AND SHALL NOT BE COPIED  
OR REPRODUCED IN ANY MANNER WITHOUT  
THE WRITTEN CONSENT OF THE TRANE COMPANY.



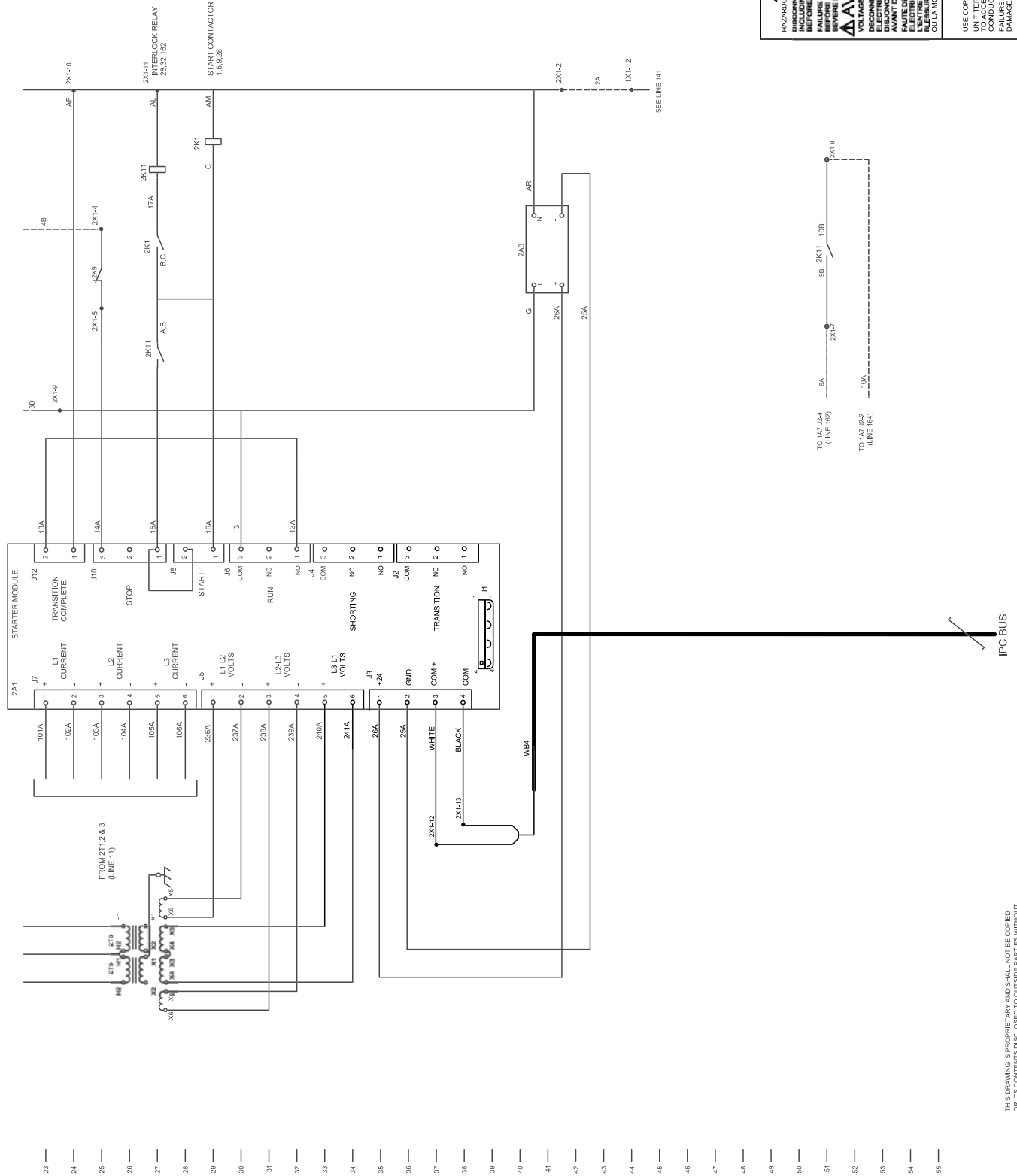

**WARNING**  
 HAZARDOUS VOLTAGE!  
 HAZARDOUS VOLTAGE SOURCES INCLUDING REMOTE DISCONNECTS BEFORE SERVICING.  
 FAILURE TO DISCONNECT POWER BEFORE SERVICING MAY CAUSE SEVERE PERSONAL INJURY OR DEATH.

**AVERTISSEMENT**  
 VOLTAGE HAZARDEUX!  
 DÉCONNECTEZ TOUTES LES SOURCES DE TENSION Y COMPRIS LES DISCONNECTS À DISTANCE AVANT D'EFFECTUER L'ENTRETIEN.  
 L'ÉCARTILLEMENT DE LA SOURCE D'ÉNERGIE PEUT ENTRAINER DES BLESSURES CORPORELLES SÈVES OU LA MORT.

**CAUTION**  
 USE COPPER CONDUCTORS ONLY!  
 ONLY THE WIRING IS NOT BE DESIGNED FOR COPPER TYPES OF CONDUCTORS.  
 FAILURE TO DO SO MAY CAUSE DAMAGE TO THE EQUIPMENT.

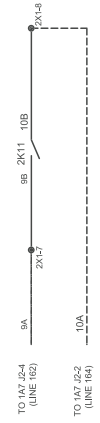

THIS DRAWING IS PROPRIETARY AND SHALL NOT BE COPIED OR ITS CONTENTS DISCLOSED TO OUTSIDE PARTIES WITHOUT THE WRITTEN CONSENT OF THE TRANE COMPANY.



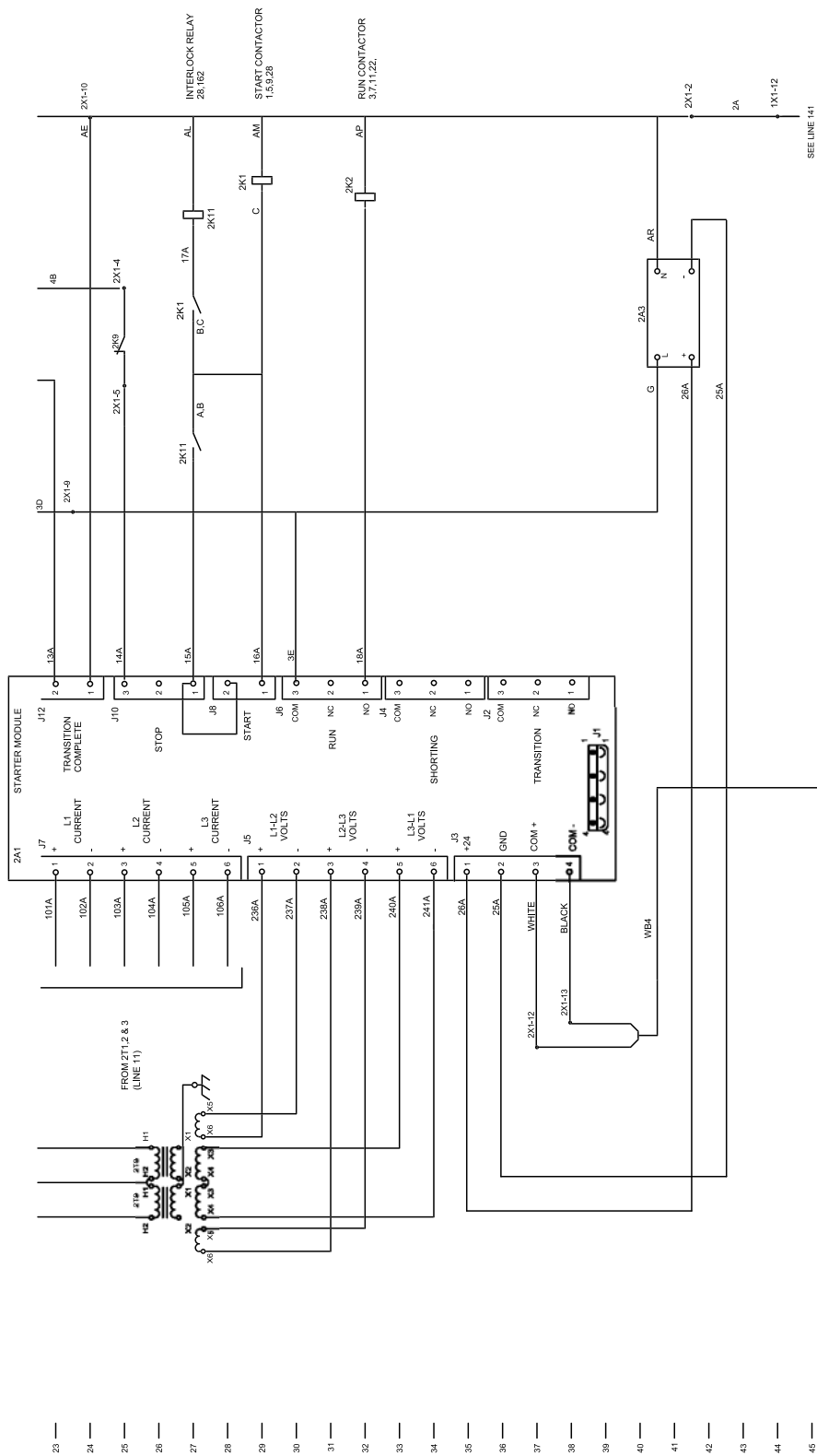

**WARNING**  
 HAZARDOUS VOLTAGE!  
 DISCONNECT ALL ELECTRIC POWER  
 BEFORE SERVICING.  
 FAILURE TO DISCONNECT POWER  
 BEFORE PERSONAL INJURY OR DEATH.  
**AVERTISSEMENT**  
 DANGER!  
 DÉCONNECTEZ TOUTES LES SOURCES  
 ÉLECTRIQUES INCLUANT LES  
 ÉLECTRONS AVANT D'EFFECTUER L'ENTRETIEN.  
 ÉLECTRICITÉ EN TENSION  
 PEUT CAUSER BLESSURES GRAVES  
 OU LA MORT.  
**CAUTION**  
 USE COPPER CONDUCTORS ONLY!  
 UNIT TERMINALS ARE NOT DESIGNED  
 FOR ALUMINUM TYPES OF  
 CONDUCTORS.  
 FAILURE TO DO SO MAY CAUSE  
 DAMAGE TO THE EQUIPMENT.

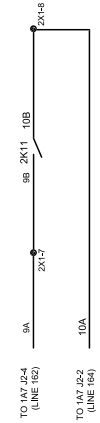

IPC BUS





2309-4912D

CH 530 SCHEMATIC WIRING CVHE, CVHF, CVHG  
UNIT MOUNTED ADAPTIVE FREQUENCY DRIVE

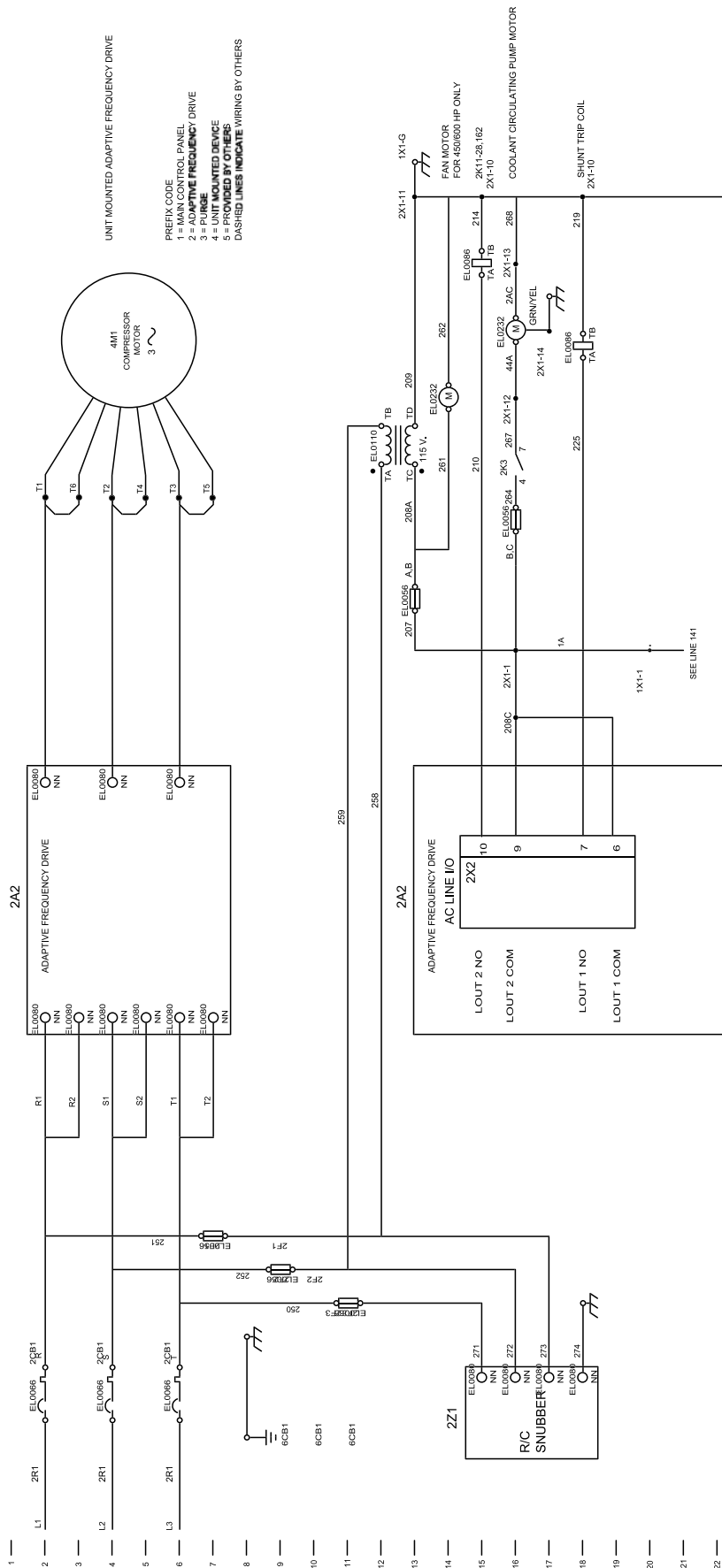

UNIT MOUNTED ADAPTIVE FREQUENCY DRIVE

PREFIX CODE  
 1 = MAIN CONTROL PANEL  
 2 = ADAPTIVE FREQUENCY DRIVE  
 3 = UNIT MOUNTED COMPRESSOR MOTOR  
 4 = UNIT MOUNTED FAN MOTOR  
 5 = UNIT MOUNTED DEVICE  
 6 = UNIT MOUNTED SHUNT TRIP COIL  
 7 = UNIT MOUNTED COOLANT CIRCULATING PUMP MOTOR  
 DASHED LINES INDICATE WIRING BY OTHERS

SEE LINE 141

23  
24  
25  
26  
27  
28  
29  
30  
31  
32  
33  
34  
35  
36  
37  
38  
39  
40  
41  
42  
43  
44  
45  
46  
47  
48  
49  
50  
51  
52  
53  
54  
55

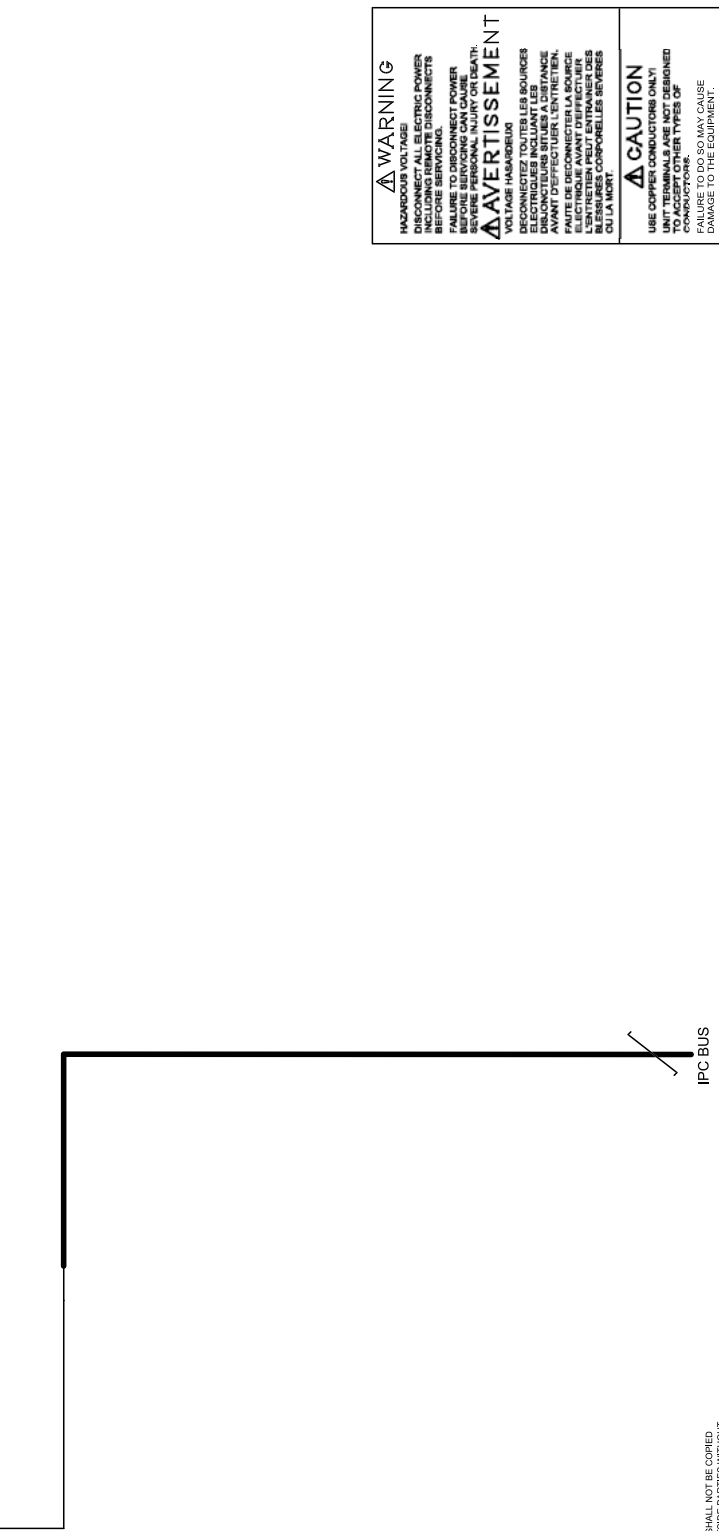
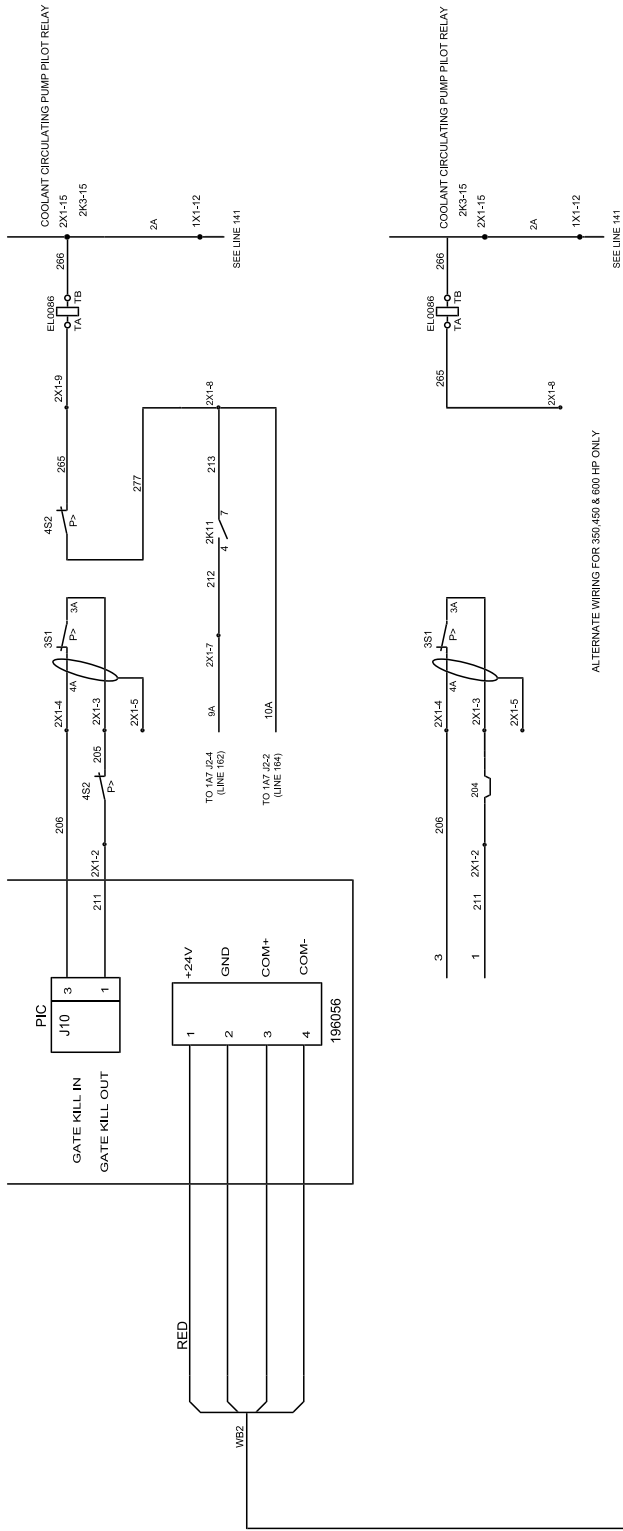

**⚠ WARNING**  
 HAZARDOUS VOLTAGE  
 DISCONNECT ALL ELECTRIC POWER  
 BEFORE SERVICING. FAILURE TO  
 DISCONNECT POWER BEFORE  
 SERVICING CAN CAUSE  
 ELECTRICAL SHOCK OR DEATH.

**⚠ AVERTISSEMENT**  
 VOLTAGE HAZARDEUX  
 DÉCONNECTER TOUTES LES SOURCES  
 ÉLECTRIQUES INCLUANT LES  
 ÉLECTRONS AVANT DE DÉCONNECTER  
 LA SOURCE ÉLECTRIQUE AVANT  
 D'INTERVENIR. L'ÉLECTRICITÉ  
 PEUT CAUSER DES BLESSURES  
 GRAVES, MÊME LA MORT.

**⚠ CAUTION**  
 USE COPPER CONDUCTORS ONLY  
 AND ACCEPT OTHER TYPES OF  
 CONDUCTORS. FAILURE TO  
 FOLLOW THESE INSTRUCTIONS  
 CAN CAUSE DAMAGE TO THE EQUIPMENT.

# 2309-4913D

## CH 530 SCHEMATIC WIRING CVHE, CVHF, CVHG CUSTOMER SUPPLIED WYE-DELTA STARTER

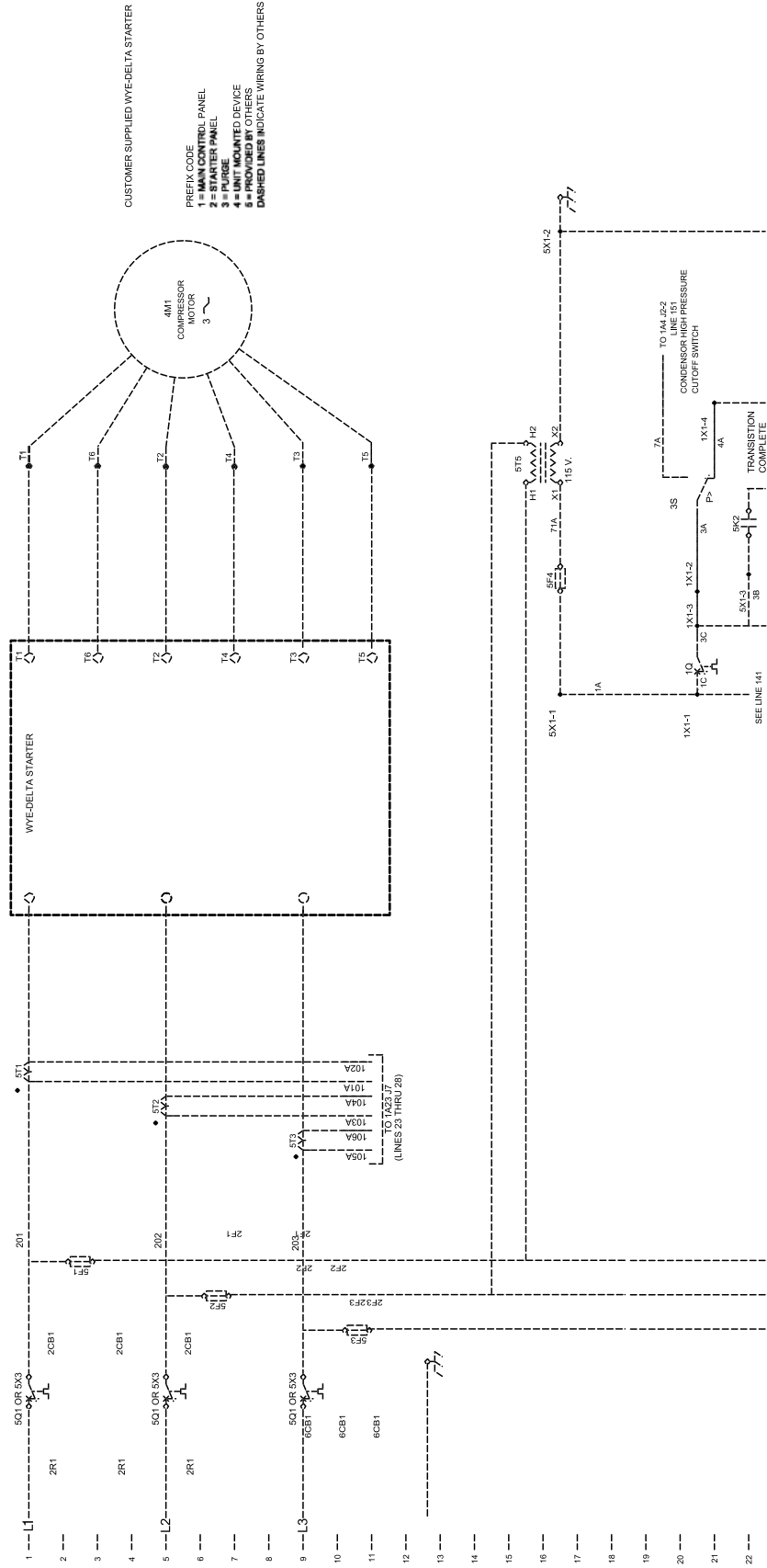

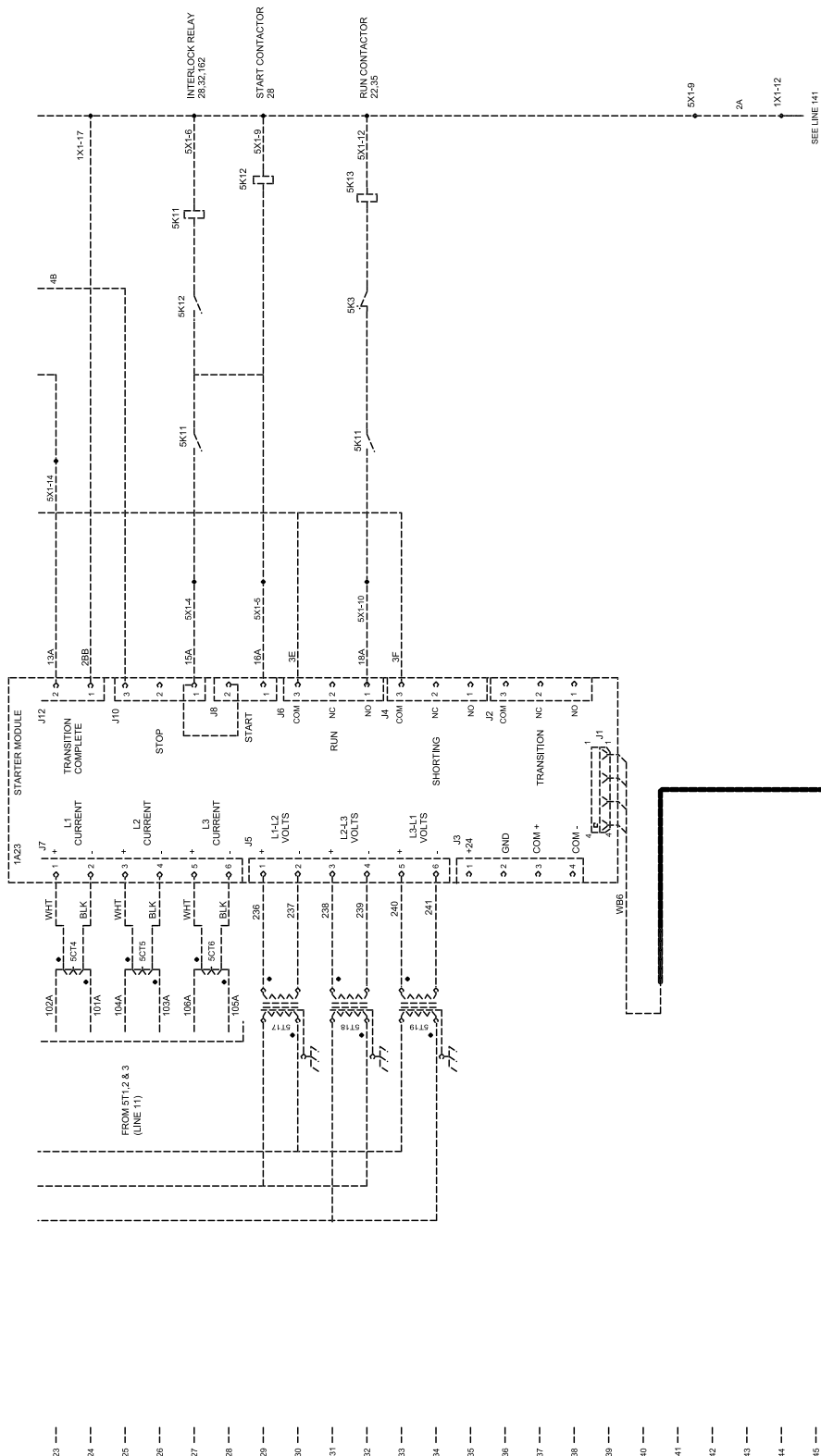

**WARNING**  
 HAZARDOUS VOLTAGE!  
 DISCONNECT ALL ELECTRIC POWER  
 BEFORE WORKING ON THIS UNIT.  
 FAILURE TO DISCONNECT POWER  
 BEFORE WORKING ON THIS UNIT  
 MAY CAUSE PERSONAL INJURY OR DEATH.

**AVERTISSEMENT**  
 VOLTAGE HAZARDEUX!  
 DECONNECTEZ TOUTES LES SOURCES  
 ELECTRIQUES INCLUANT LES  
 ALIMENTATIONS AVANT D'EFFECTUER LE TRAVAIL.  
 FAUTE DE DECONNECTER LA SOURCE  
 ELECTRIQUE AVANT D'EFFECTUER LE  
 TRAVAIL PEUT ENTRAINER DES  
 BLESSURES CORPORELLES SEVERES  
 OU LA MORT.

**CAUTION**  
 USE COPPER CONDUCTORS ONLY.  
 UNIT TERMINALS ARE NOT DESIGNED  
 FOR ALUMINUM CONDUCTORS.  
 FAILURE TO DO SO MAY CAUSE  
 DAMAGE TO THE EQUIPMENT.

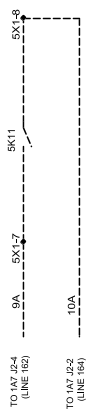

WIRE AND TERMINAL NOS ARE REFERENCE ONLY

THIS DRAWING IS PROPERTY AND SHALL NOT BE COPIED  
 OR ITS CONTENTS DISCLOSED TO OUTSIDE PARTIES WITHOUT  
 THE WRITTEN CONSENT OF THE TRANE COMPANY

2309-4914 D

CH 530 SCHEMATIC WIRING CVHE, CVHF, CVHG  
 CUSTOMER SUPPLIED PRIMARY REACTOR OR AUTO-TRANSFORMER STARTER

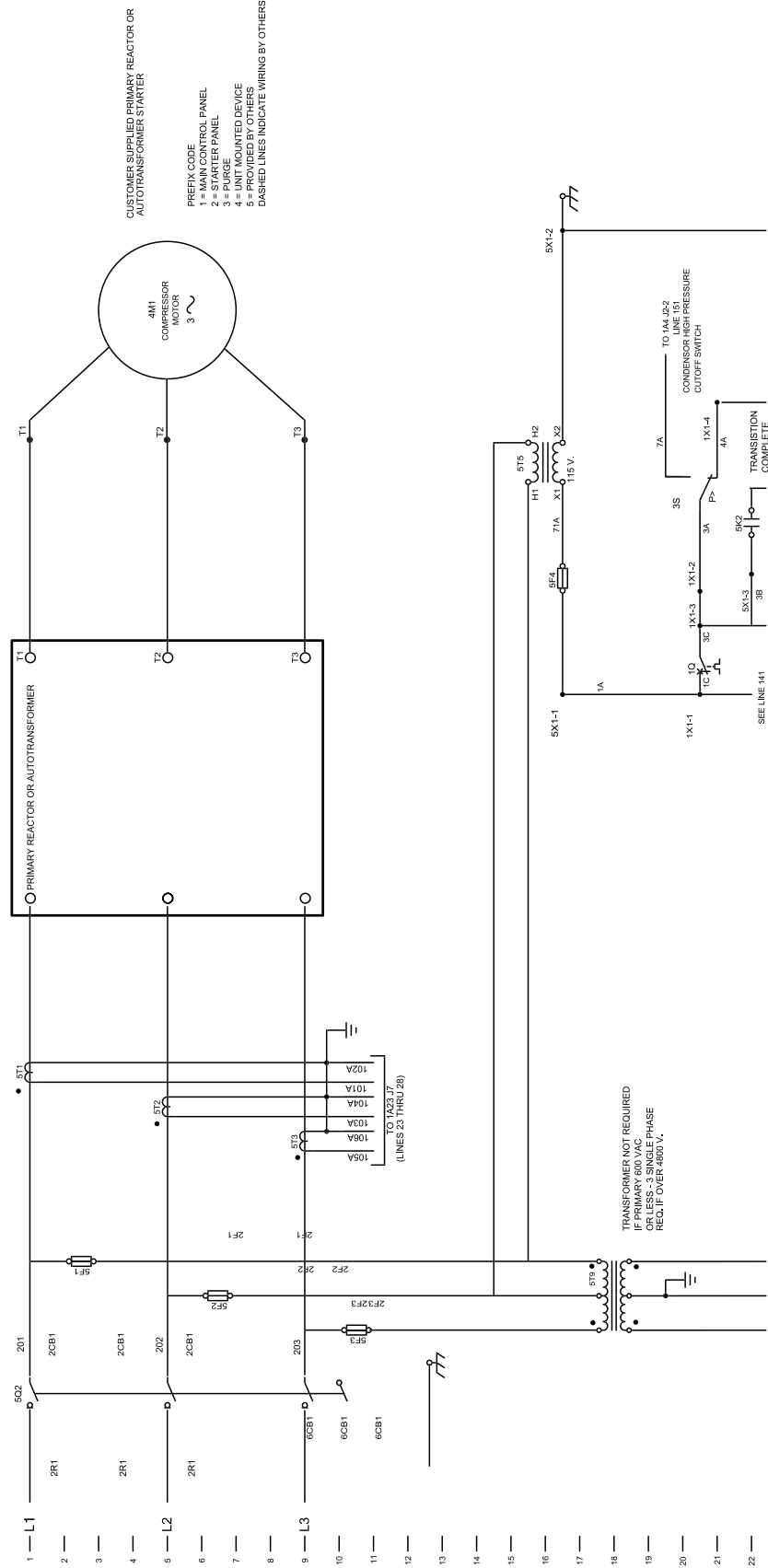

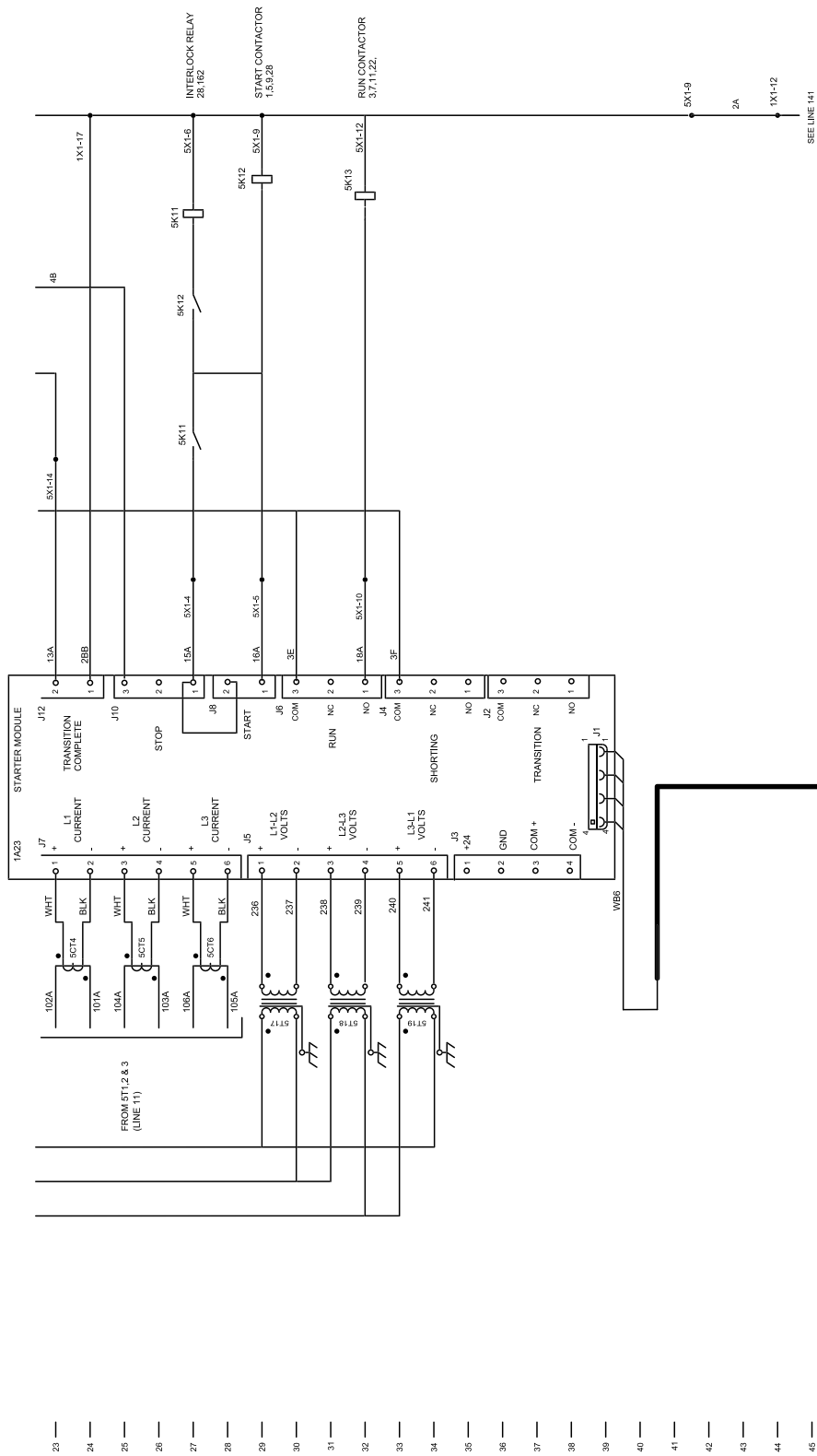

<p><b>WARNING</b> HAZARDOUS VOLTAGE! DISCONNECT ALL ELECTRIC POWER BEFORE SERVICING. FAILURE TO DISCONNECT POWER MAY CAUSE PERSONAL INJURY OR DEATH.</p>	<p><b>AVERTISSEMENT</b> VOLTAGE HAZARDEUX! DECONNECTEZ TOUTES LES SOURCES ELECTRIQUES INCLUANT LES CONDENSATEURS AVANT D'EFFECTUER LE RENTRETIEN. FAUTE DE DECONNECTER LA SOURCE D'ALIMENTATION PEUT CAUSER DES BLESSES CORPORELLES SEVERES OU LA MORT.</p>
<p><b>CAUTION</b> USE COPPER CONDUCTORS ONLY. UNIT TERMINALS ARE NOT DESIGNED FOR ALUMINUM CONDUCTORS. FAILURE TO DO SO MAY CAUSE DAMAGE TO THE EQUIPMENT.</p>	

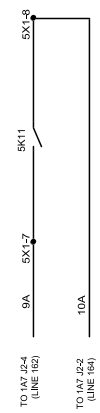

WIRE AND TERMINAL NOS ARE REFERENCE ONLY

THIS DRAWING IS PROPRIETARY AND SHALL NOT BE COPIED,  
OR ITS CONTENTS DISCLOSED TO OUTSIDE PARTIES WITHOUT  
THE WRITTEN CONSENT OF THE TRANE COMPANY

# 2309-4915D

## CH 530 SCHEMATIC WIRING CVHE, CVHF, CVHG CUSTOMER SUPPLIED ACROSS THE LINE STARTER

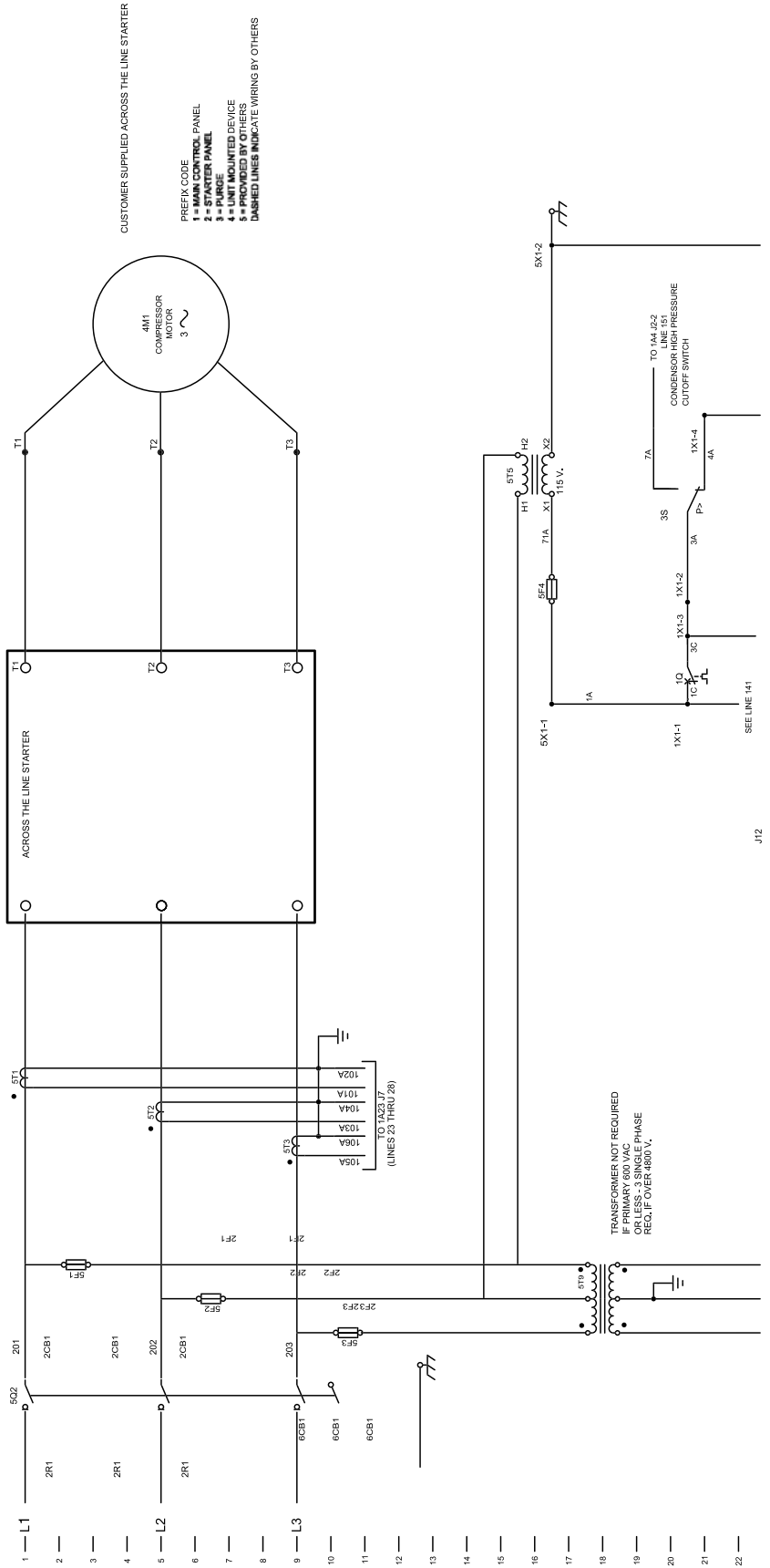





23 —  
24 —  
25 —  
26 —  
27 —  
28 —  
29 —  
30 —  
31 —  
32 —  
33 —  
34 —  
35 —  
36 —  
37 —  
38 —  
39 —  
40 —  
41 —  
42 —  
43 —  
44 —  
45 —  
46 —  
47 —  
48 —  
49 —  
50 —  
51 —  
52 —  
53 —  
54 —  
55 —

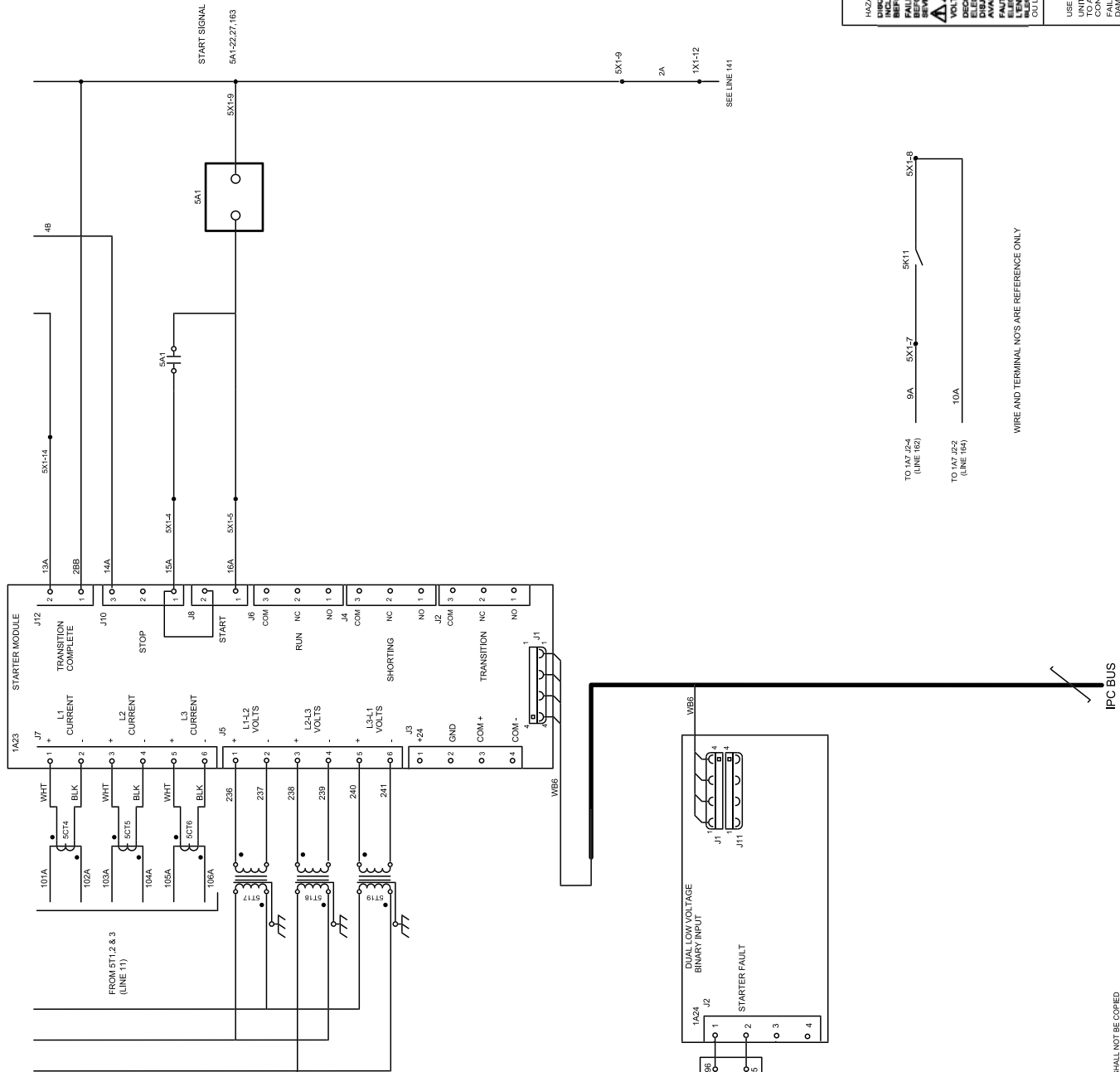

**WARNING**  
HAZARDOUS VOLTAGE!  
DISCONNECT ALL POWER SOURCES INCLUDING BATTERIES BEFORE SERVICING.  
FAILURE TO DISCONNECT POWER SOURCES MAY CAUSE PERSONAL INJURY OR DEATH.

**AVERTISSEMENT**  
VOLTAGE HAZARDEUX!  
DECONNECTEZ TOUTES LES SOURCES ELECTRIQUES INCLUANT LES BATTERIES AVANT D'EFFECTUER L'ENTRETIEN.  
FAUTE DE DECONNECTER LA SOURCE ELECTRIQUE PEUT ENTRAINER DES BLESSURES CORPORELLES SEVERES OU LA MORT.

**CAUTION**  
USE COPPER CONDUCTORS ONLY!  
UNIT TERMINALS ARE NOT DESIGNED FOR ALUMINUM CONDUCTORS!  
FAILURE TO DO SO MAY CAUSE DAMAGE TO THE EQUIPMENT.

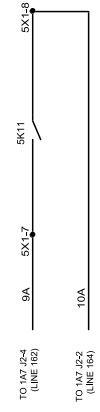

WIRE AND TERMINAL NOS ARE REFERENCE ONLY

THIS DRAWING IS PROPRIETARY AND SHALL NOT BE COPIED OR ITS CONTENTS DISCLOSED TO OUTSIDE PARTIES WITHOUT THE WRITTEN CONSENT OF THE TRANE COMPANY

2309-4917 C

CH 530 SCHEMATIC WIRING CVHE, CVHF, CVHG  
PRODUCTION PURGE

61 —  
62 —  
63 —  
64 —  
65 —  
66 —  
67 —  
68 —  
69 —  
70 —  
71 —  
72 —  
73 —  
74 —  
75 —  
76 —  
77 —  
78 —  
79 —  
80 —  
81 —  
82 —  
83 —  
84 —  
85 —

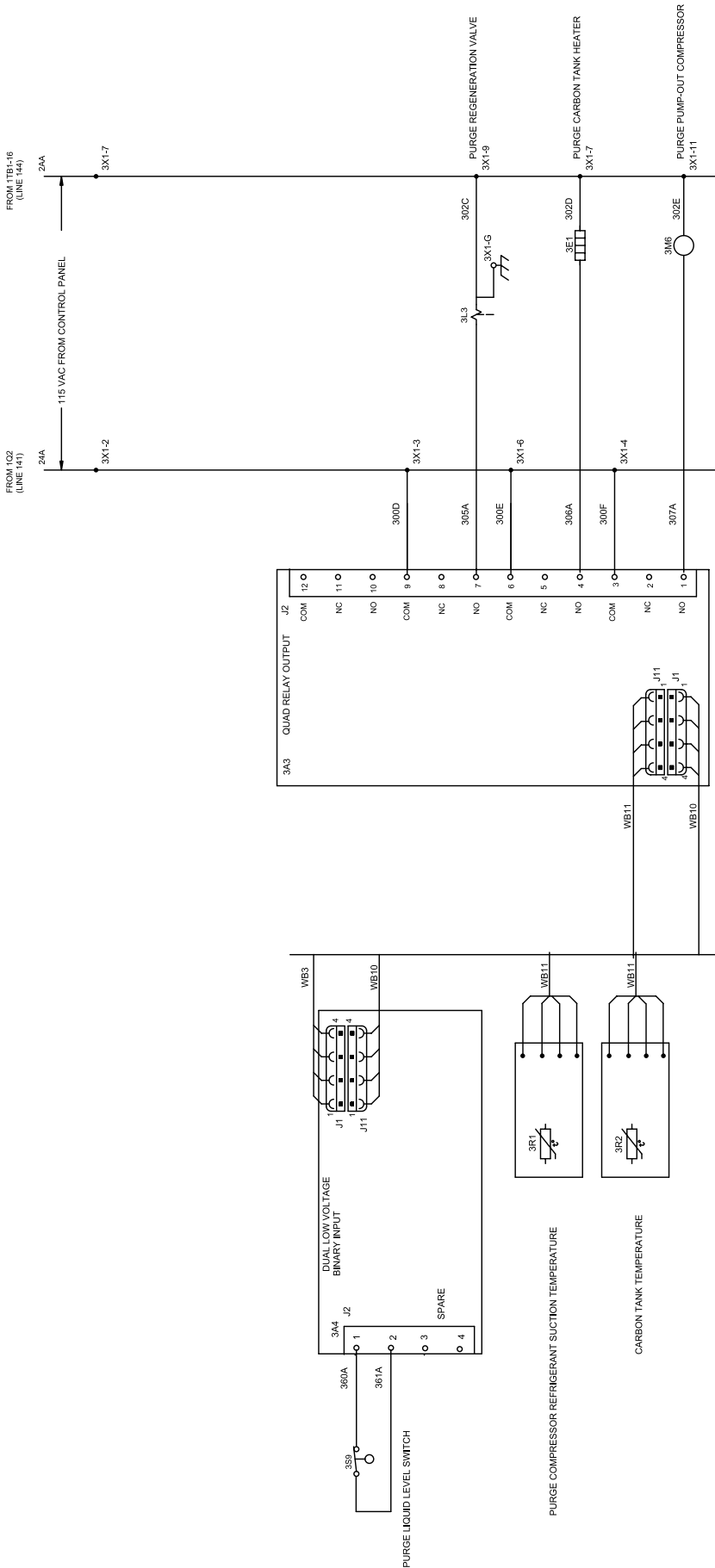



# 2309-4919D

## CH 530 SCHEMATIC WIRING CVHE, CVHF, CVHG UNIT CONTROLS SCHEMATIC

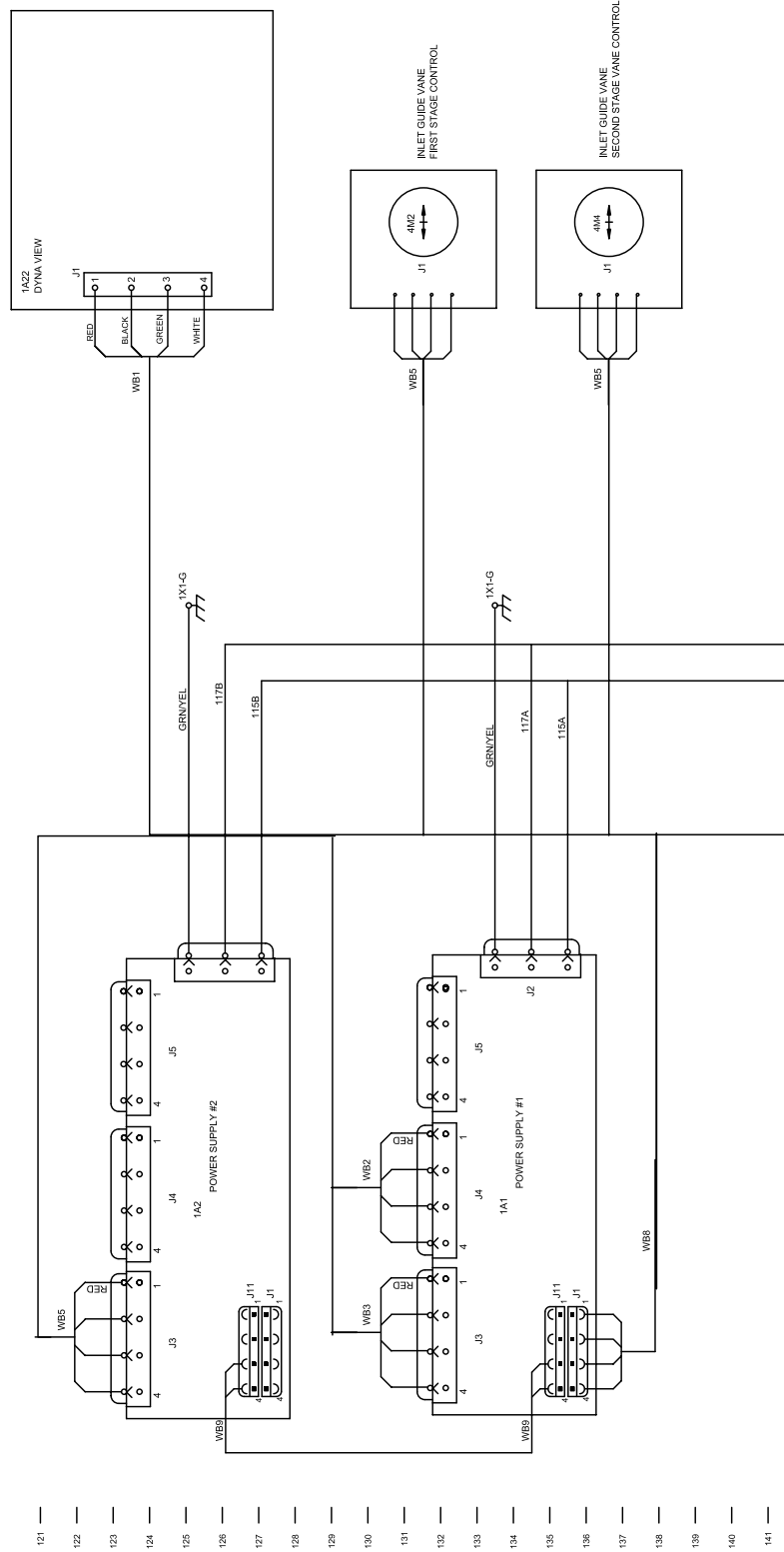

- 121
- 122
- 123
- 124
- 125
- 126
- 127
- 128
- 129
- 130
- 131
- 132
- 133
- 134
- 135
- 136
- 137
- 138
- 139
- 140
- 141

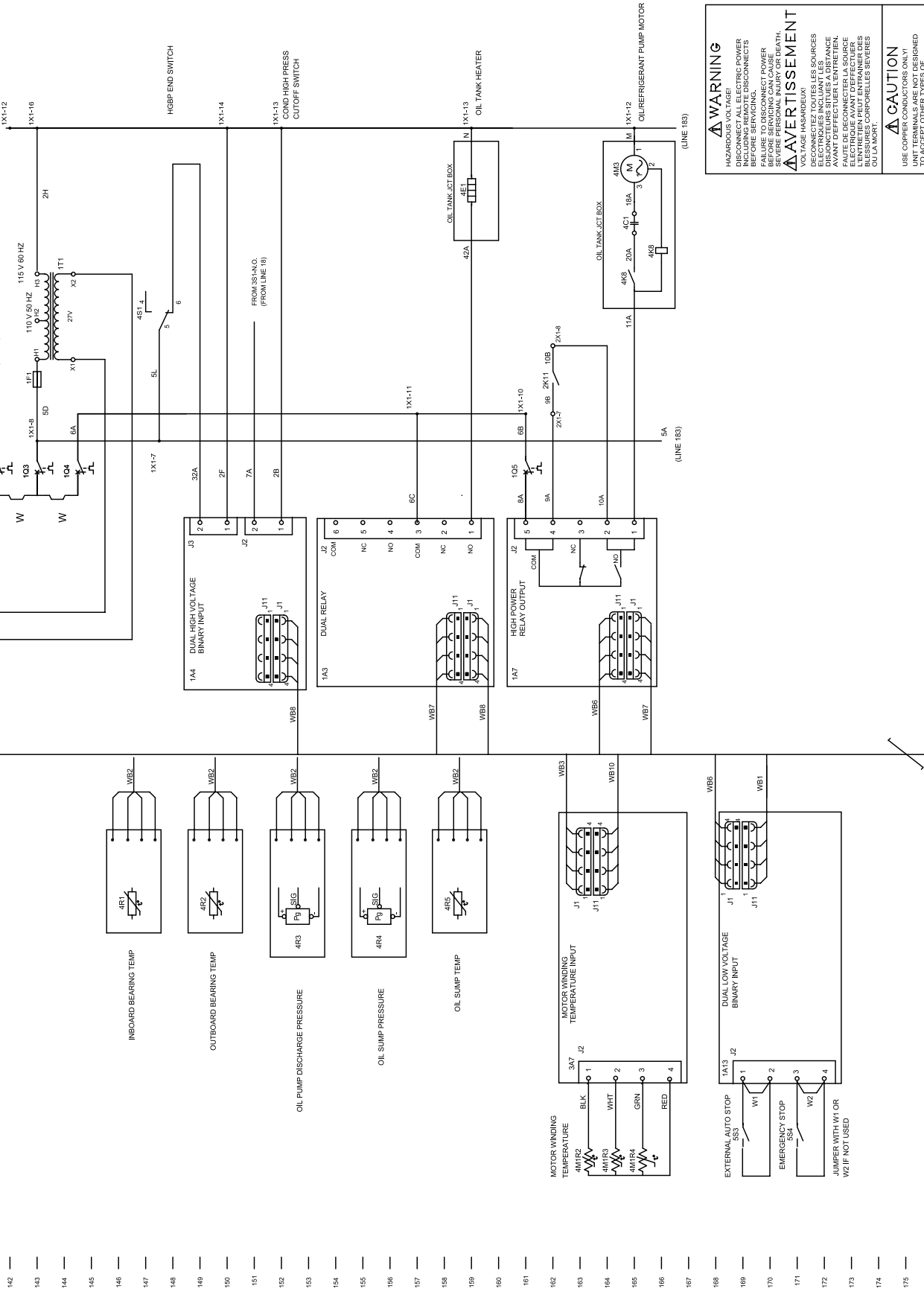

THIS DRAWING IS PROPRIETARY. ALL RIGHTS RESERVED. NO PARTS MAY BE COPIED OR ITS CONTENTS DISCLOSED TO OUTSIDE PARTIES WITHOUT THE WRITTEN CONSENT OF THE TRANE COMPANY.

# 2309-4920 D

## CH 530 SCHEMATIC WIRING CVHE, CVHF, CVHG SYSTEM CONTROLS SCHEMATIC

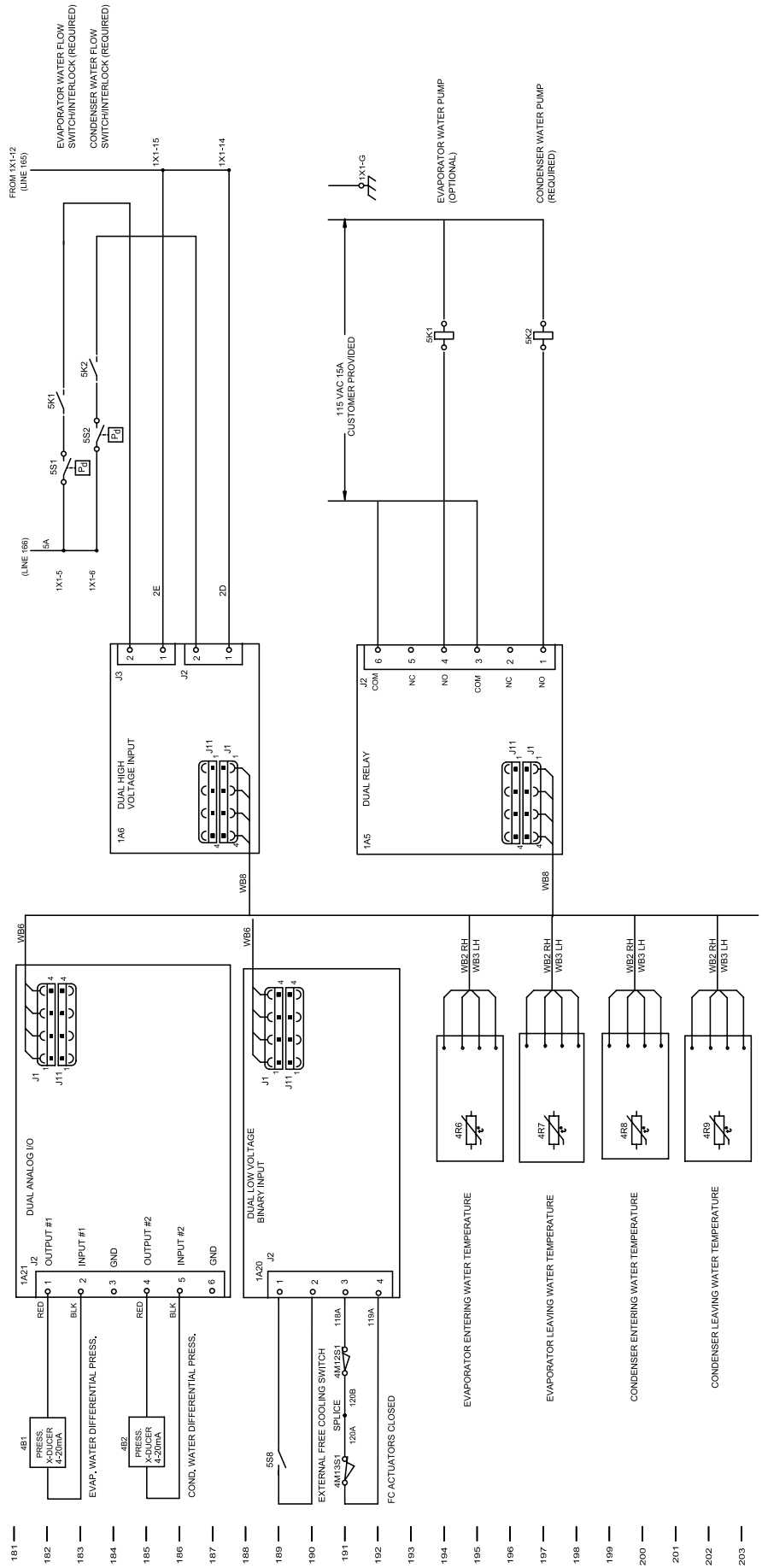

- 204
- 205
- 206
- 207
- 208
- 209
- 210
- 211
- 212
- 213
- 214
- 215
- 216
- 217
- 218
- 219
- 220
- 221
- 222
- 223
- 224
- 225
- 226
- 227
- 228
- 229
- 230
- 231
- 232
- 233
- 234
- 235
- 236
- 237
- 238

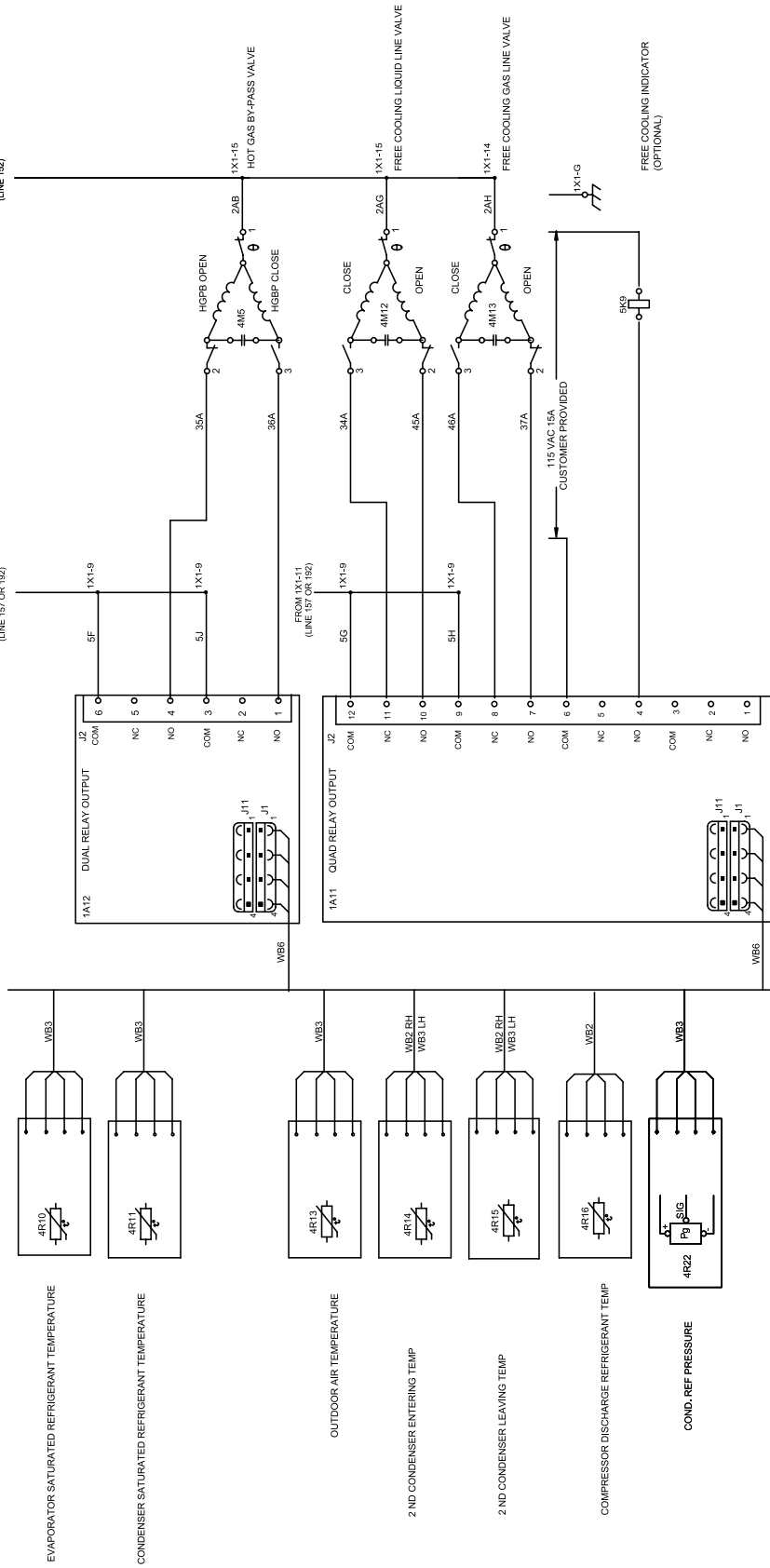

<p><b>⚠ WARNING</b></p> <p>HAZARDOUS VOLTAGE! DISCONNECT ALL ELECTRIC POWER INCLUDING REMOTE DISCONNECTS BEFORE SERVICING. RECONNECTING OR CONTACTING ELECTRICAL PARTS BEFORE SERVICING CAN CAUSE SEVERE PERSONAL INJURY OR DEATH.</p> <p><b>⚠ AVERTISSEMENT</b></p> <p>VOLTAGE HASARDEUX! DECONNECTEZ TOUTES LES SOURCES D'ÉLECTRICITÉ Y COMPRIS LES DÉCONNECTEURS À DISTANCE AVANT D'EFFECTUER L'ENTRETIEN. FAUTE DE DÉCONNECTER LA SOURCE D'ÉLECTRICITÉ PEUT ENTRAINER DES BLESSURES CORPORELLES SÈVÈRES OU LA MORT.</p>	<p><b>⚠ CAUTION</b></p> <p>USE COPPER CONDUCTORS ONLY! UNIT TERMINALS ARE NOT DESIGNED TO ACCEPT OTHER TYPES OF CONDUCTORS. FAILURE TO DO SO MAY CAUSE DAMAGE TO THE EQUIPMENT.</p>
---	---

IPC BUS

THIS DRAWING IS PROPRIETARY AND SHALL NOT BE COPIED OR REPRODUCED IN ANY MANNER WITHOUT THE WRITTEN CONSENT OF THE TRANE COMPANY.

2309-4921 C

CH 530 SCHEMATIC WIRING CVHE, CVHF, CVHG  
OPTIONS SCHEMATIC

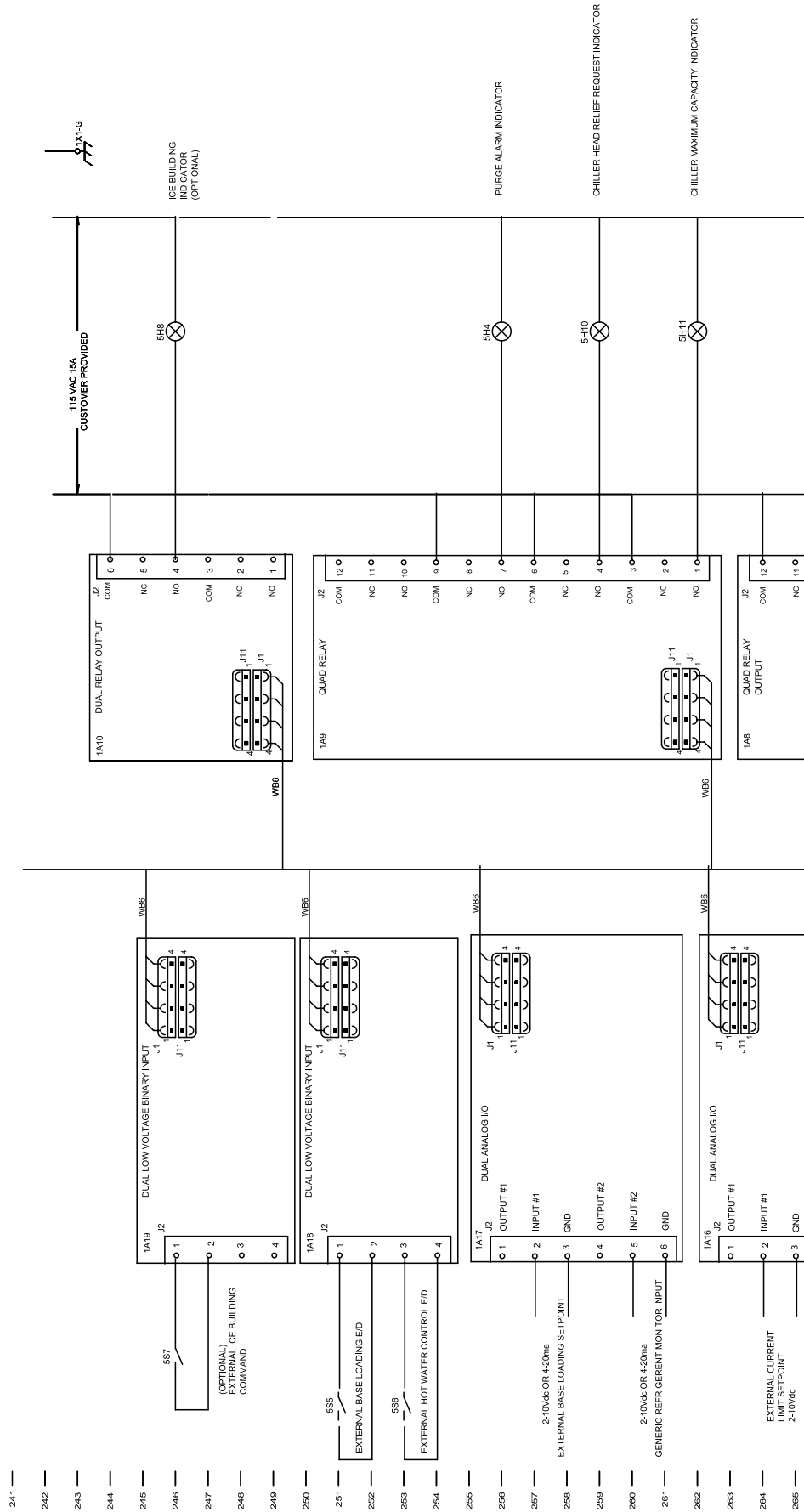

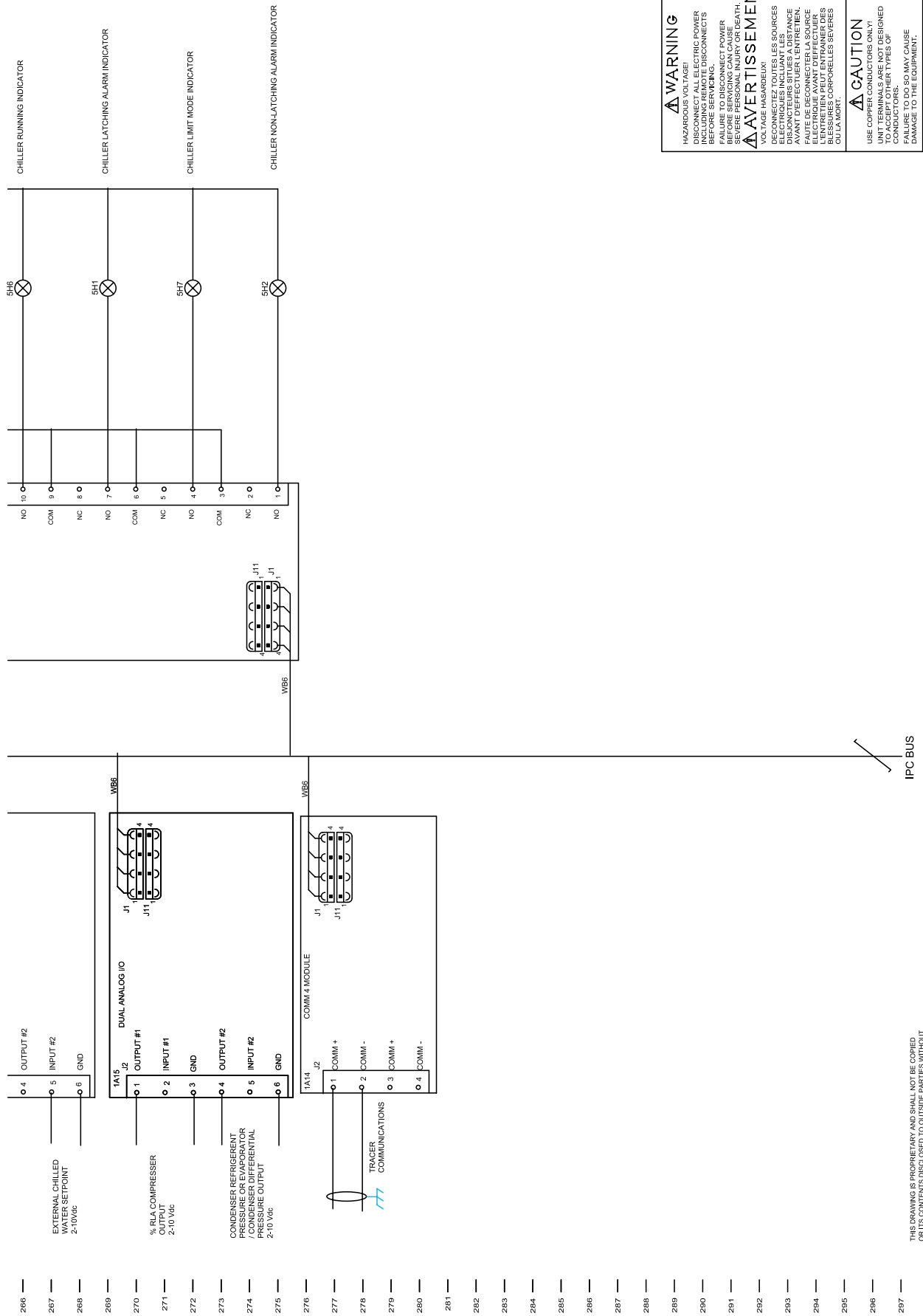

**⚠ WARNING**  
 HAZARDOUS VOLTAGE  
 DISCONNECT ALL ELECTRIC POWER INCLUDING REMOTE DISCONNECTS BEFORE SERVICING.  
 FAILURE TO DISCONNECT POWER BEFORE SERVICING CAN CAUSE SEVERE PERSONAL INJURY OR DEATH.  
**⚠ AVERTISSEMENT**  
 VOLTAGE HASARDEUX!  
 DECONNECTEZ TOUTES LES SOURCES DE PUISSANCE ÉLECTRIQUE, Y COMPRIS LES DISCONNECTS SITUÉS À DISTANCE, AVANT D'EFFECTUER L'ENTRETIEN. FAUTE DE DÉCONNECTER LA SOURCE DE PUISSANCE ÉLECTRIQUE PEUT ENTRAÎNER DES BLESSURES CORPORELLES SÈVÈRES OU LA MORT.

**⚠ CAUTION**  
 USE COPPER CONDUCTORS ONLY! UNIT TERMINALS ARE NOT DESIGNED TO ACCEPT OTHER TYPES OF CONDUCTORS.  
 FAILURE TO DO SO MAY CAUSE DAMAGE TO THE EQUIPMENT.

THIS DRAWING IS PROPRIETARY AND SHALL NOT BE COPIED OR REPRODUCED IN ANY MANNER WITHOUT THE WRITTEN CONSENT OF THE TRANE COMPANY.

**2309-4923D**

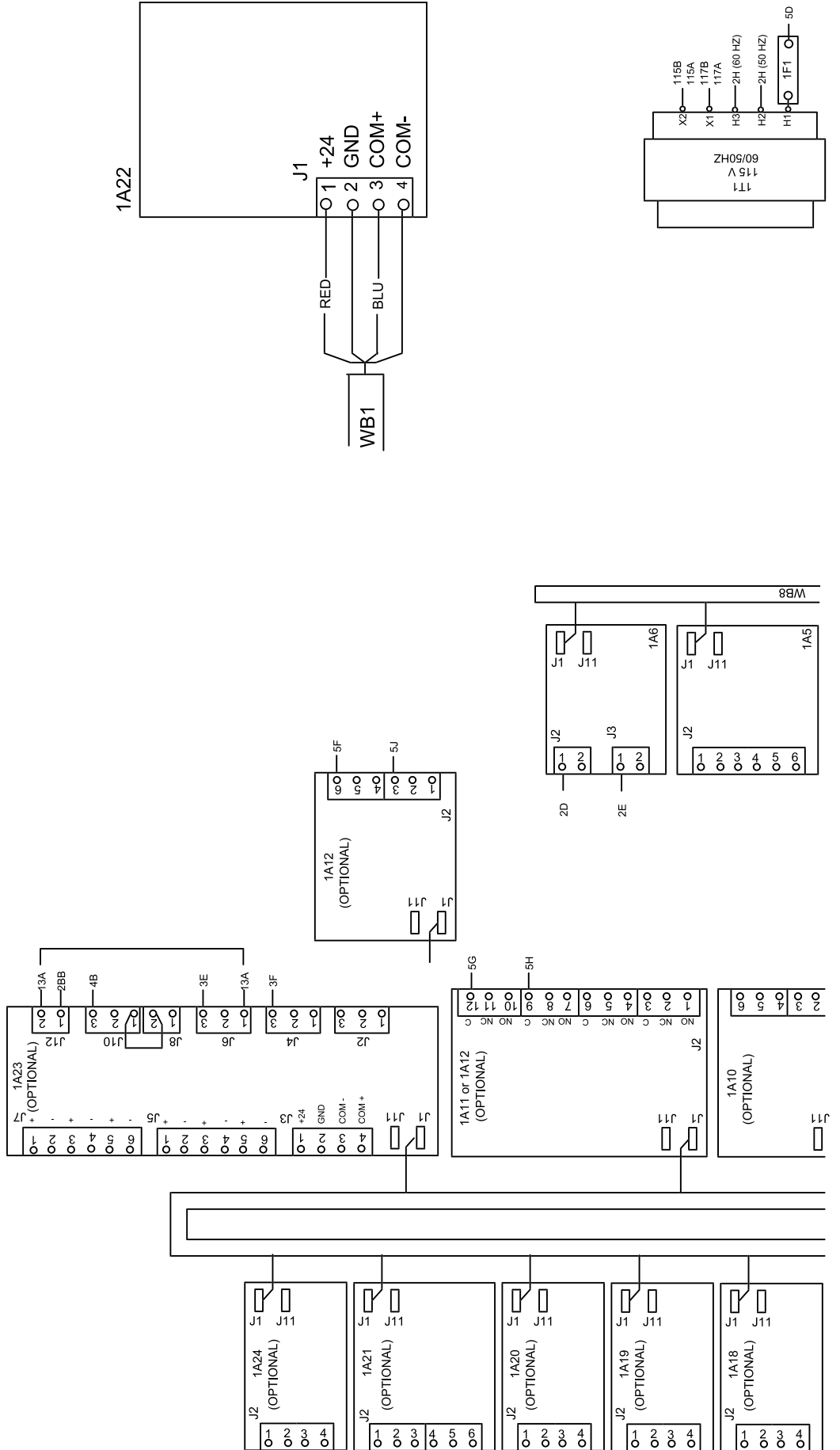



# 2309-4935D

CONNECTION DIAGRAM  
 FIELD CONNECTION - TRANE STARTER  
 CH 530  
 CVHE,CVHF,CVHG

## UNIT CONTROL PANEL

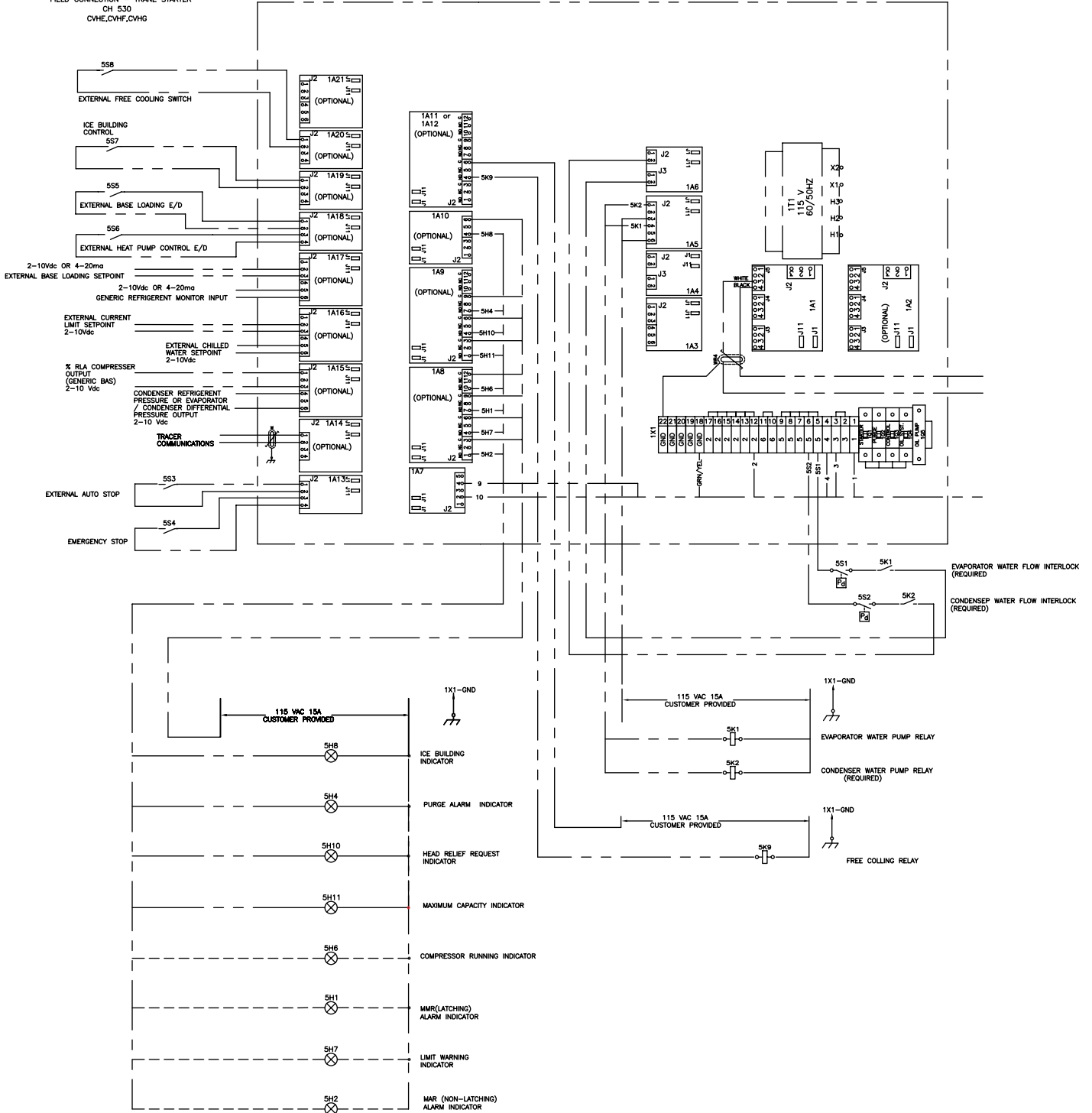

S G THOMPSON

8-13-01

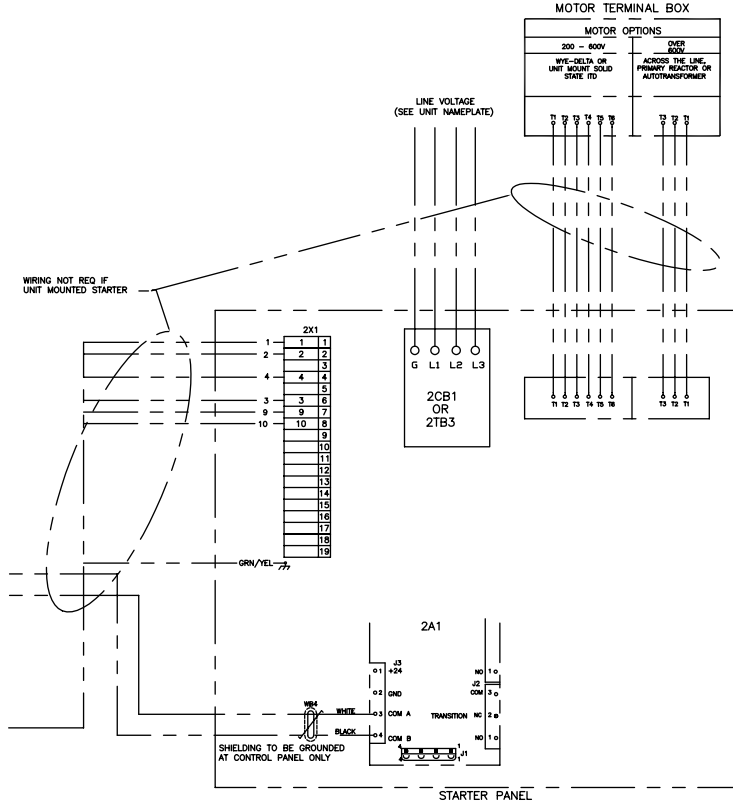

**NOTES:**

1. DASHED LINES INDICATE FIELD WIRING BY OTHERS. CHECK SALES ORDER TO DETERMINE WHICH OPTIONS ARE SPECIFIED.
2. DO NOT ROUTE LOW VOLTAGE (30V MAX) WITH CONTROL VOLTAGE (115V) AND DO NOT POWER UNIT UNTIL CHECK-OUT AND START-UP PROCEDURES HAVE BEEN COMPLETED.
3. EVAPORATOR AND CONDENSER FLOW SWITCHES ARE REQUIRED. THEY CONTAIN DPDT CONTACTS. THE SEPERATE FLOW SWITCHES ARE RUN IN SERIES WITH SEPERATE AUX CONTACTS FOR THE CONDENSER PUMP AND SEPERATE AUX CONTACTS FOR THE EVAPORATOR PUMP. THEY MUST BE INSTALLED AND WIRED TO THE APPROPRIATE TRANE PANEL BY THE INSTALLING CONTRACTOR. PURCHASE OF SWITCHES FROM THE TRANE CO. IS OPTIONAL.

<b>⚠ WARNING</b>
HAZARDOUS VOLTAGE! DISCONNECT ALL ELECTRIC POWER INCLUDING REMOTE DISCONNECTS BEFORE SERVICING. FAILURE TO DISCONNECT POWER BEFORE SERVICING CAN CAUSE SEVERE PERSONAL INJURY OR DEATH.
<b>⚠ AVERTISSEMENT</b>
VOLTAGE HASARDEUX! DÉCONNECTEZ TOUTES LES SOURCES ÉLECTRIQUES INCLUANT LES DISJONCTEURS SITUÉS À DISTANCE AVANT D'EFFECTUER L'ENTRETIEN. FAUTE DE DÉCONNECTER LA SOURCE ÉLECTRIQUE AVANT D'EFFECTUER L'ENTRETIEN PEUT ENTRAÎNER DES BLESSURES CORPORELLES SEVERES OU LA MORT.
<b>⚠ CAUTION</b>
USE COPPER CONDUCTORS ONLY! UNIT TERMINALS ARE NOT DESIGNED TO ACCEPT OTHER TYPES OF CONDUCTORS. FAILURE TO DO SO MAY CAUSE DAMAGE TO THE EQUIPMENT.



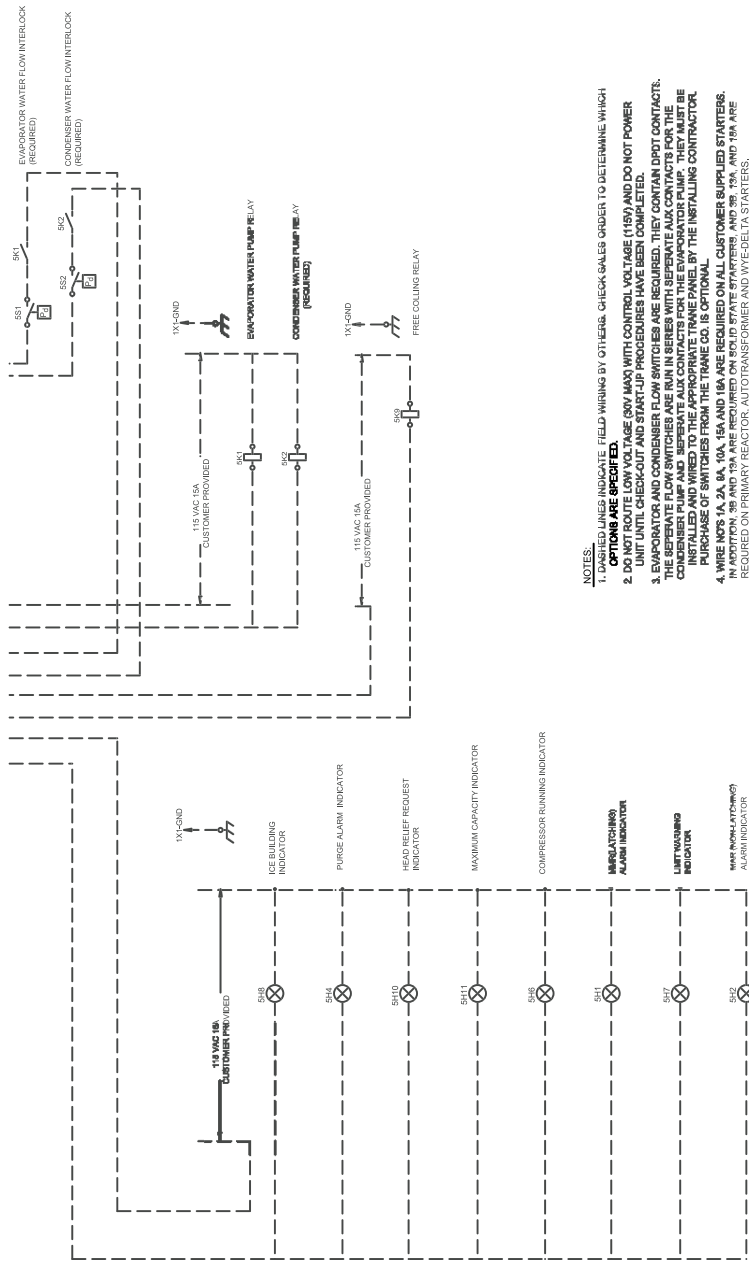

- NOTES:**
1. DASHED LINES INDICATE FIELD WIRING BY OTHERS. CHECK SALES ORDER TO DETERMINE WHICH OPTIONS ARE SPECIFIED.
  2. UNIT MUST BE SHUT OFF AND STARTUP PROCEDURES MUST BE COMPLETED.
  3. EVAPORATOR AND CONDENSER FLOW SWITCHES ARE REQUIRED. THEY CONTAIN DIRT CONTACTS. THE SEPARATE FLOW SWITCHES ARE RUN IN SERIES WITH SEPARATE AUX CONTACTS FOR THE CONDENSER PUMP AND SEPARATE AUX CONTACTS FOR THE EVAPORATOR PUMP. THEY MUST BE PURCHASED SEPARATELY FROM THE MAIN FLOW SWITCHES BY THE INSTALLING CONTRACTOR.
  4. WIRE NOS 1A, 2A, 9A, 10A, 16A AND 18A ARE REQUIRED ON ALL CUSTOMER SUPPLIED STARTERS. IN ADDITION, 3B AND 13A ARE REQUIRED ON 50/10 STATE STARTERS AND 3B, 18A, AND 19A ARE REQUIRED ON PRIMARY REACTOR, AUTOTRANSFORMER AND WYE-DELTA STARTERS.

**⚠ WARNING**  
 HAZARDOUS VOLTAGE  
 DISCONNECT ALL ELECTRIC POWER  
 BEFORE SERVICING.  
 FAILURE TO DISCONNECT POWER  
 BEFORE SERVICING MAY CAUSE  
 SEVERE PERSONAL INJURY OR DEATH.

**⚠ AVERTISSEMENT**  
 DANGER  
 DÉCONNECTEZ TOUTES LES SOURCES  
 ÉLECTRIQUES AVANT D'ENTREPRENDRE  
 DES TRAVAUX D'ENTRETIEN.  
 L'ÉLECTRICITÉ PEUT ENTRAINER DES  
 BLESSURES CORPORELLES GRAVES  
 OU LA MORT.

**⚠ CAUTION**  
 USE COPPER CONDUCTORS ONLY!  
 UNIT TERMINALS ARE NOT DESIGNED  
 FOR ALUMINUM TYPES OF  
 CONDUCTORS.  
 FAILURE TO DO SO MAY CAUSE  
 DAMAGE TO THE EQUIPMENT.

# 2309-4937D

## CONNECTION DIAGRAM UNIT WIRING STANDARD CH 530 CVHE,CVHF,CVHG

S G THOMPSON  
5-15-01

NOTES:  
1. WATER TEMP. SENSORS MAY BE CONNECTED TO 4-WIRE COMMUNICATOR LINK CABLE WB2 FOR RIGHT HAND END OR WB3 FOR LEFT HAND END DEPENDING ON WATER BOX PASS ARRANGEMENT.

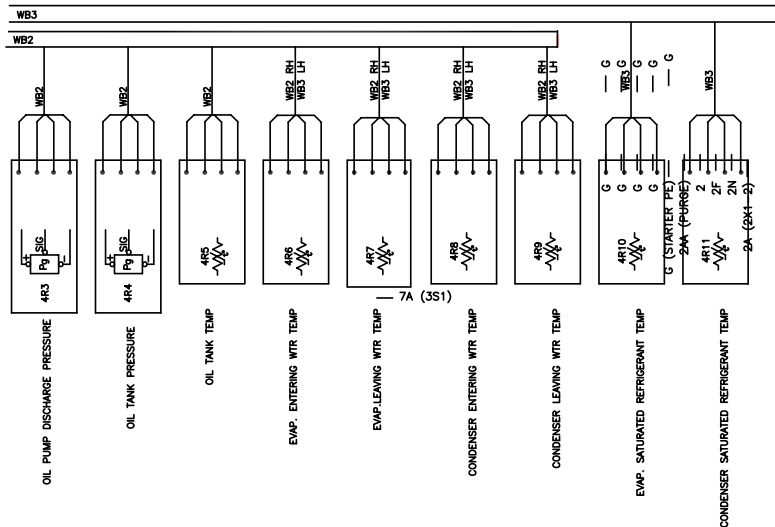
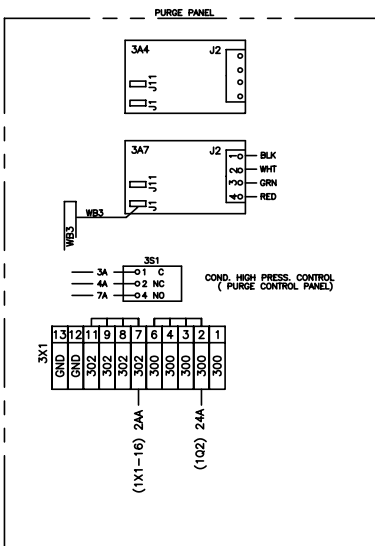
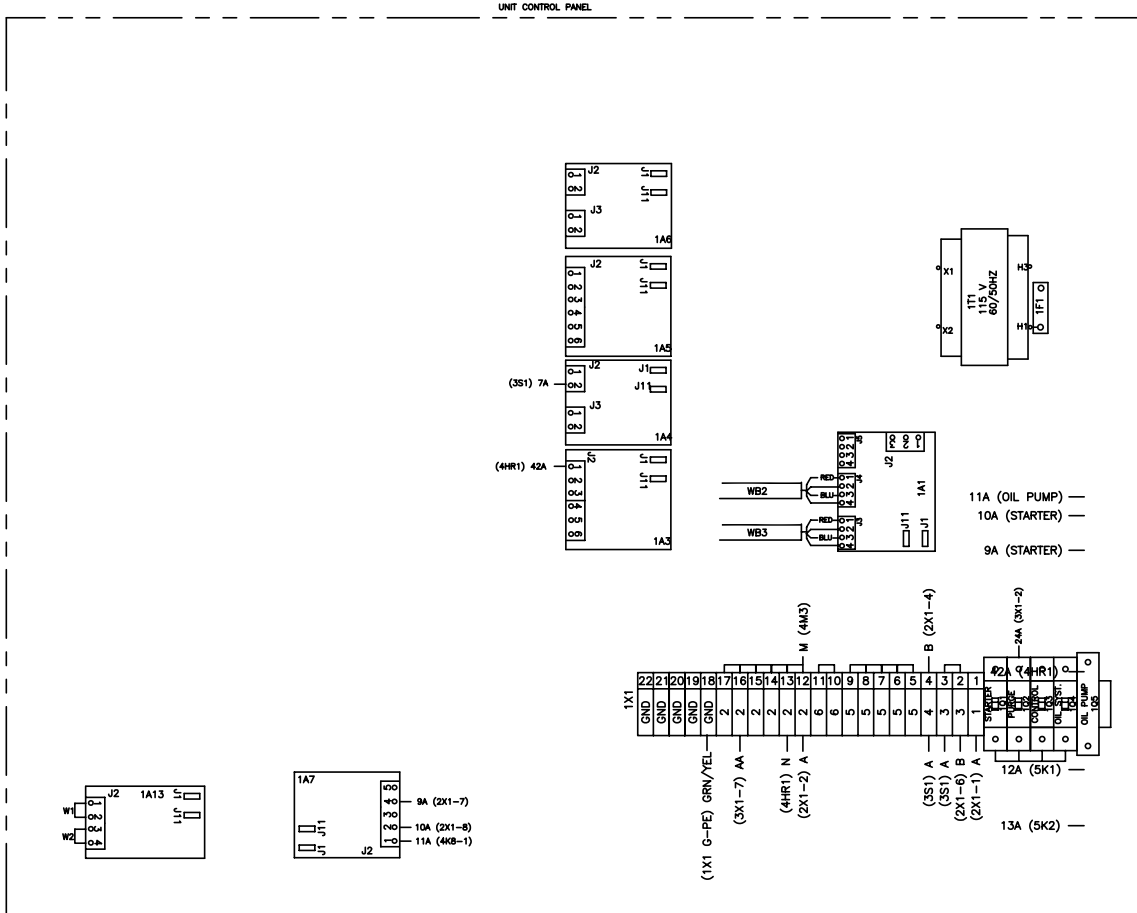

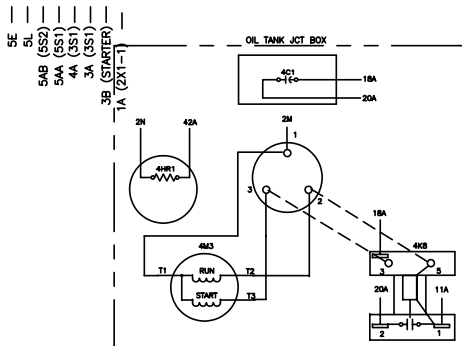
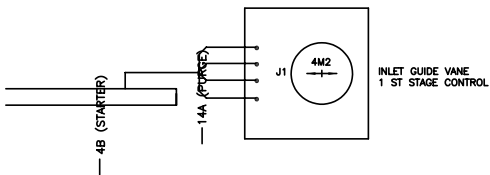
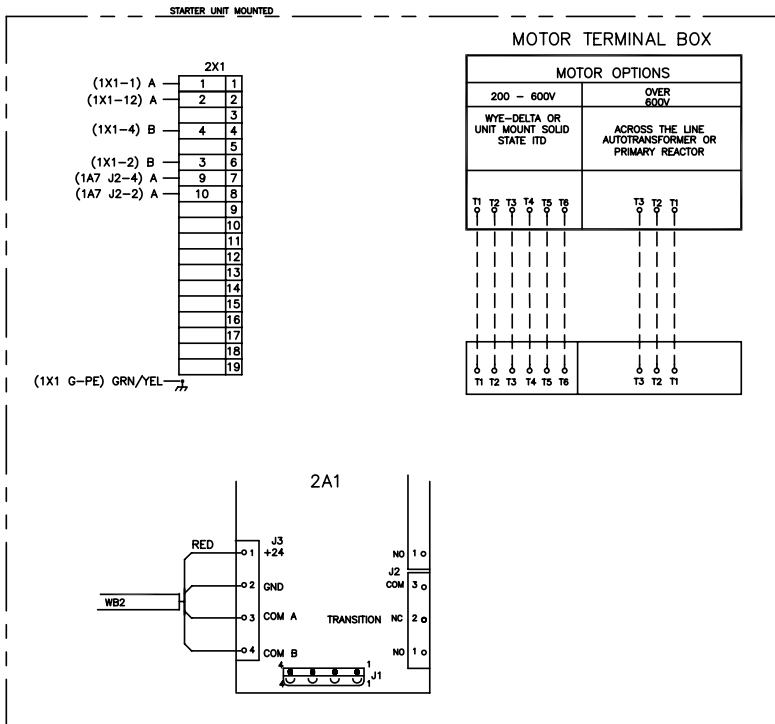
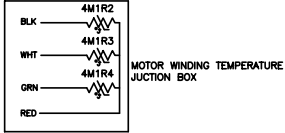

**WARNING**  
 HAZARDOUS VOLTAGE!  
 DISCONNECT ALL ELECTRIC POWER INCLUDING REMOTE DISCONNECTS BEFORE SERVICING.  
 FAILURE TO DISCONNECT POWER BEFORE SERVICING CAN CAUSE SEVERE PERSONAL INJURY OR DEATH.

**AVERTISSEMENT**  
 VOLTAGE HASARDEUX!  
 DECONNECTEZ TOUTES LES SOURCES ELECTRIQUES INCLUANT LES DISJONCTEURS SITUES A DISTANCE AVANT D'EFFECTUER L'ENTRETIEN.  
 FAUTE DE DECONNECTER LA SOURCE ELECTRIQUE AVANT D'EFFECTUER L'ENTRETIEN PEUT ENTRAINER DES BLESSURES CORPORELLES SEVERES OU LA MORT.

**CAUTION**  
 USE COPPER CONDUCTORS ONLY!  
 UNIT TERMINALS ARE NOT DESIGNED TO ACCEPT OTHER TYPES OF CONDUCTORS.  
 FAILURE TO DO SO MAY CAUSE DAMAGE TO THE EQUIPMENT.

# 2309-4938E

## CONNECTION DIAGRAM

UNIT WIRING OPTIONAL  
CH 530  
CVHE, CVHF, CVHG

S G THOMPSON

5-21-01

### NOTES:

1. WATER TEMP. SENSORS MAY BE CONNECTED TO 4-WIRE COMMUNICATION LINK CABLE WB2 FOR RIGHT HAND END OR WB3 FOR LEFT HAND END DEPENDING ON WATER BOX PASS ARRANGEMENT.
2. WIRING SHOWN IS FOR UNIT MOUNTED STARTER, IF REMOTE STARTER IS USED SEE DRG. 2309-4935 OR IF CUSTOMER SUPPLIED STARTER SEE DRG. 2309-4936.

### UNIT CONTROL PANEL

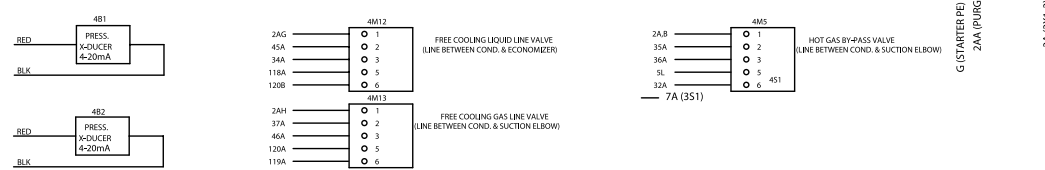
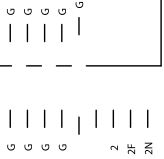
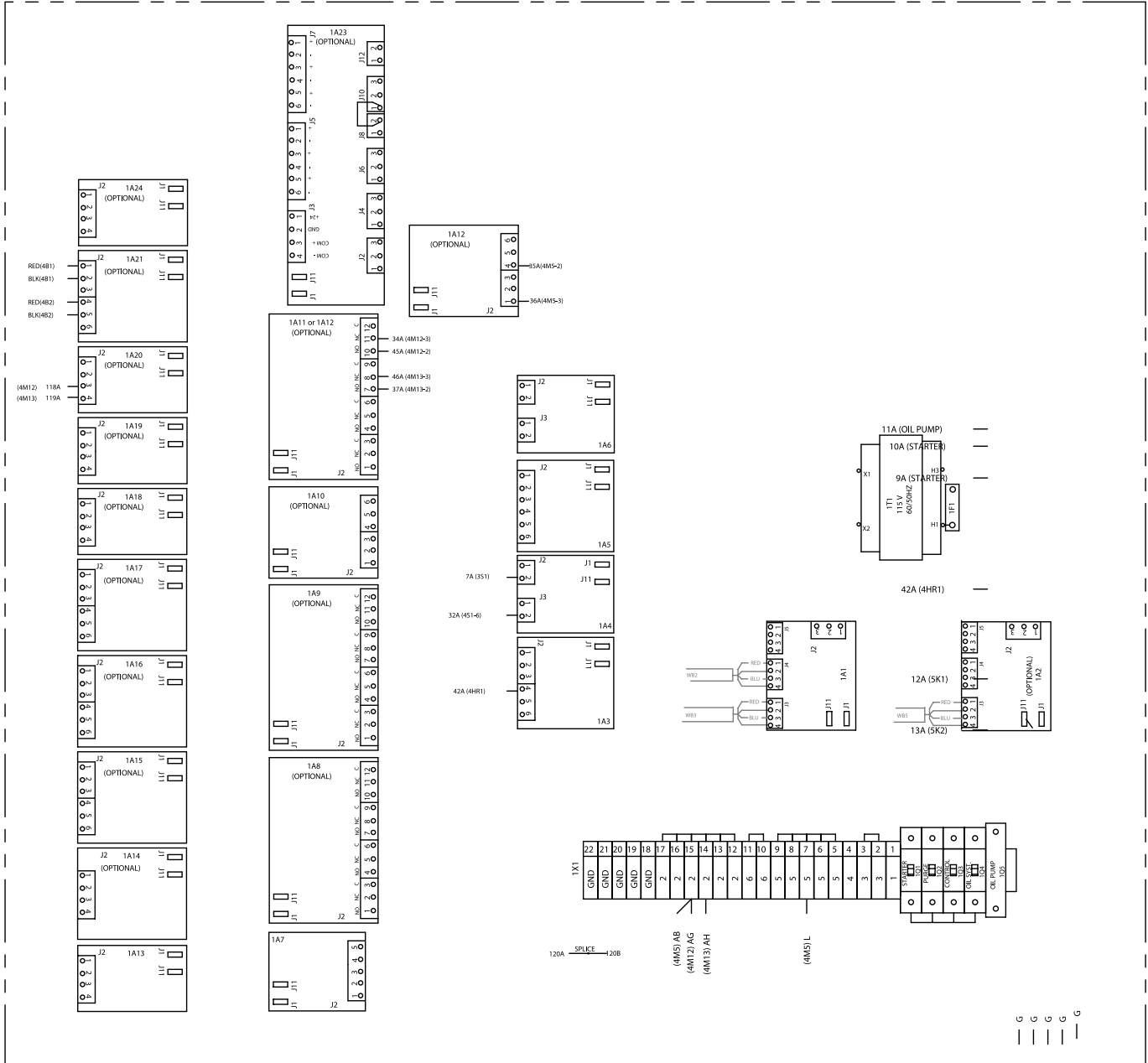

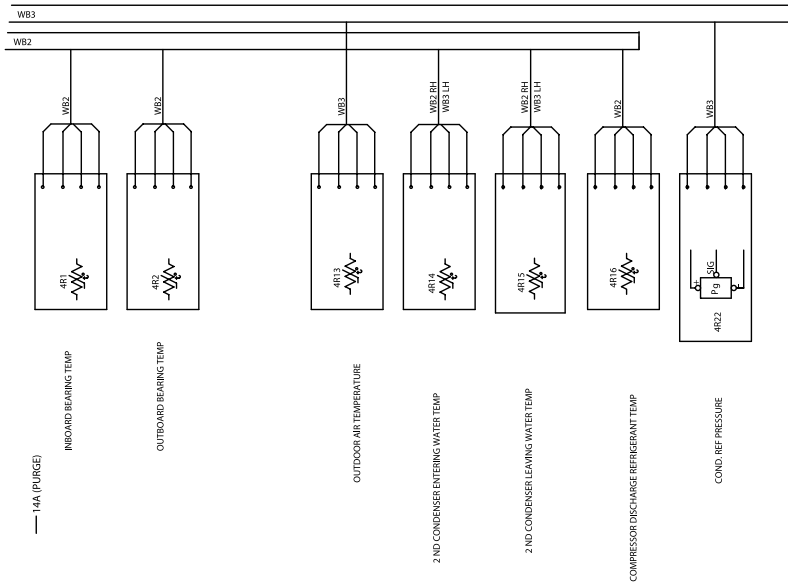
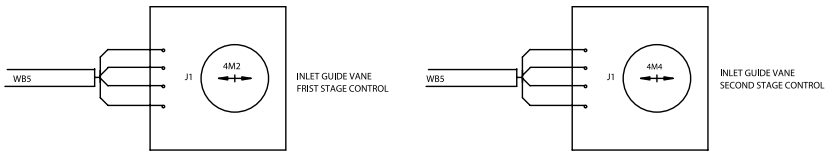

— 4B (STARTER)

— 14A (PURGE)

- SE
- 5L
- 5AB (SS2)
- 5AA (SS1)
- 4A (SS1)
- 3A (SS1)
- 3B (STARTER)
- 1A (2X1-1)

**⚠ WARNING**  
**HAZARDOUS VOLTAGE!**  
 DISCONNECT ALL ELECTRIC POWER INCLUDING REMOTE DISCONNECTS BEFORE SERVICING.  
 FAILURE TO DISCONNECT POWER BEFORE SERVICING CAN CAUSE SEVERE PERSONAL INJURY OR DEATH.

**⚠ AVERTISSEMENT**  
**VOLTAGE HASARDEUX!**  
 DECONNECTEZ TOUTES LES SOURCES ELECTRIQUES INCLUANT LES DISJONCTEURS SITUÉS A DISTANCE AVANT D'EFFECTUER L'ENTRETIEN. FAUTE DE DECONNECTER LA SOURCE ELECTRIQUE AVANT D'EFFECTUER L'ENTRETIEN PEUT ENTRAINER DES BLESSURES CORPORELLES SEVERES OU LA MORT.

**⚠ CAUTION**  
 USE COPPER CONDUCTORS ONLY! UNIT TERMINALS ARE NOT DESIGNED TO ACCEPT OTHER TYPES OF CONDUCTORS.  
 FAILURE TO DO SO MAY CAUSE DAMAGE TO THE EQUIPMENT.

2309-4939C

CONNECTION DIAGRAM

PURGE CONTROL PANEL  
CH 530  
CVHE,CVHF,CVHG  
PRODUCTION

S G THOMPSON  
3-27-01

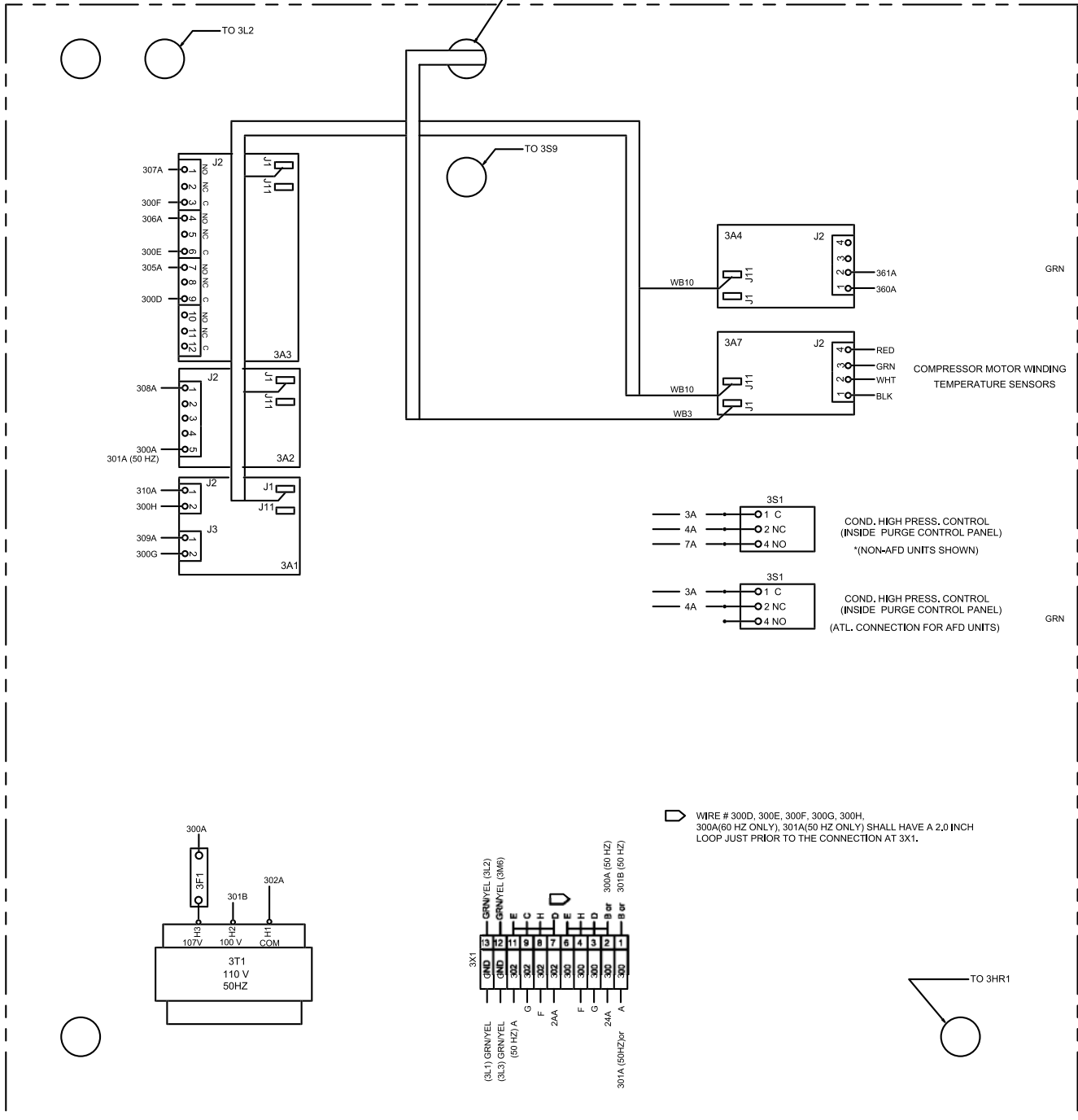
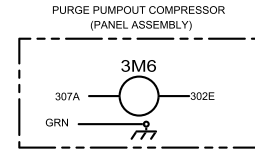
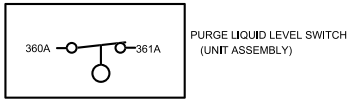
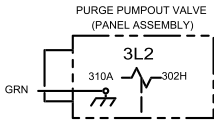

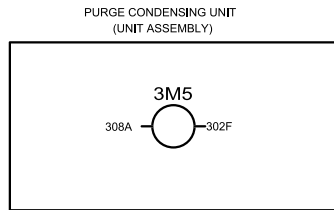
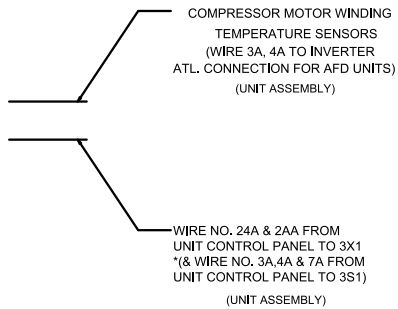
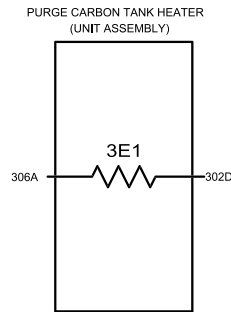
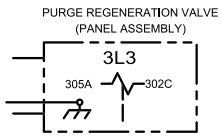
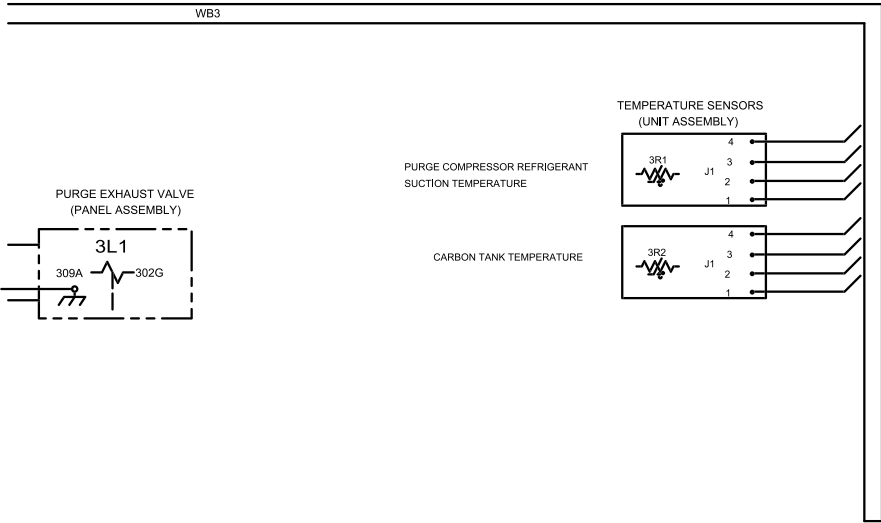

2309-4922 C

## CH 530 SCHEMATIC WIRING CVHE, CVHF, CVHG LEGEND

DEVICE DESIGNATION	DESCRIPTION	LINE NUMBER
1A1	24 VDC POWER SUPPLY #1	PAGE 3
1A2	24 VDC POWER SUPPLY #2	PAGE 3
1A3	OIL TANK HEATER CONTROL RELAY	PAGE 3
1A4	COND. HIGH PRESS. & HGPB SWITCH INPUT	PAGE 3
1A5	COND. & EVAP. WTR PUMP & OIL TANK HEATER CONT	PAGE 4
1A6	COND. & EVAP. WATER FLOW SWITCH/INTERLOCK INPUT	PAGE 4
1A7	OIL/REFRIGERANT PUMP MOTOR CONTROL RELAY	PAGE 3
1A8	NON & LATCHING ALRM. LIM & RUNNING IND RLY	PAGE 5
1A9	HEAD RELIEF REQ. MAX CAP & PURGE ALARM	PAGE 5
1A10	ICE INDICATOR CONTROL RELAY	PAGE 5
1A11	FREE COOLING RELAY OUTPUTS	PAGE 4
1A12	HOT GAS BY-PASS VALVE CONTROL RELAY	PAGE 4
1A13	EXT. AUTO/STOP & EMERGENCY STOP INPUT	PAGE 3
1A14	COMM 4 MODULE	PAGE 5
1A15	%RLA COMP. & COND. REFR. PRESSURE OUTPUT	PAGE 5
1A16	EXT. CUR. LIMIT & CHILLED WATER SETPOINT INPUTS	PAGE 5
1A17	EXT. BASE LOADING SETPOINT & REF. MONITOR INPUT	PAGE 5
1A18	EXT. BASE LOADING & EXT. HOT WATER E/D INPUTS	PAGE 5
1A19	EXTERNAL ICE MAKING COMMAND INPUT	PAGE 5
1A20	EXT. FREE COOL. CMD & FREE COOL. V. CLSD INPUT	PAGE 4
1A21	EVAP. & COND. WATER DIFFERENTIAL PRES. INPUTS	PAGE 4
1A22	DYNA VIEW	PAGE 3
1F1	CONTROL POWER FUSE	143
1Q1	CIRCUIT BREAKER - STARTER	21
1Q2	PURGE CONTROL CIRCUIT BREAKER	141
1Q3	UNIT CONTROL CIRCUIT BREAKER	143
1Q4	OIL/REFRIGERANT CONTROL CIRCUIT BREAKER	145
1Q5	OIL/REFRIGERANT PUMP MOTOR CIRCUIT BREAKER	161
1T1	CONTROL POWER TRANSFORMER	144
1X1	CONTROL PANEL TERM BLOCK	
2C1	POWER FACTOR CORRECTION CAPACITOR	12
2A1	STARTER MODULE	PAGE 1
2F1,2,3	CONTROL POWER PRIMARY FUSING	3,6,10
2F4	CONTROL POWER SECONDARY FUSE	16
2K1	START CONTACTOR	29
2K2	RUN CONTACTOR	32
2K3	SHORTING CONTACTOR	35
2K4	TRANSITION CONTACTOR	38
2K9	GROUND FAULT RELAY	17
2K11	INTERLOCKING RELAY	27
2Q1	MAIN CIRCUIT BREAKER	1,5,9
2T1,2,3	LINE CURRENT TRANSFORMER	2,5,8
2T5	CONTROL POWER TRANSFORMER	12
2T17,18,19	LINE POTENTIAL TRANSFORMER	18,20,22
2X1	STARTER PANEL TERMINAL BLOCK	
2X3	LINE POTENTIAL TERMINAL BLOCK	
2T15	GROUND FAULT TORROID	1
3A1	PURGE PUMPOUT & EXHAUST VALVE CONTROL	PAGE 2
3A2	PURGE CONDENSING UNIT CONTROL RELAY	PAGE 2
3A3	PURGE PUMPOUT, HEATER, REGEN & ALARM RELAYS	PAGE 2
3A4	PURGE LIQUID LEVEL SWITCH INPUT	PAGE 2
3A7	MOTOR WINDING TEMPERATURE 1,2 & 3 INPUTS	164
3E1	PURGE CARBON TANK HEATER	82
3L1	PURGE EXHAUST VALVE	94
3L2	PURGE PUMPOUT VALVE	96
3L3	PURGE REGENERATION VALVE	79
3M5	PURGE CONDENSING UNIT	91
3M6	PURGE PUMPOUT COMPRESSOR	85
3R1	PURGE COMPRESSOR REFRIG. SUCTION TEMP. SENSOR	165
3R2	PURGE CARBON TANK TEMPERATURE SENSOR	75
3S1	CONDENSER HIGH PRESS. CUTOFF SWITCH	19
3S9	PURGE LIQUID LEVEL SWITCH	77

DEVICE DESIGNATION	DESCRIPTION	LINE NUMBER
4B1	EVAPORATOR WATER DIFFERENTIAL PRESSURE	182
4B2	CONDENSER WATER DIFFERENTIAL PRESSURE	185
4M12S1	FREE COOLING LIQUID LINE SWITCH	191
4M13S1	FREE COOLING GAS LINE SWITCH	191
4C1	OIL/REFRIGERANT PUMP MOTOR CAPACITOR	165
4E1	OIL TANK HEATER	159
4K8	OIL/REFRIGERANT PUMP MOTOR CONTROL RELAY	166
4M1	COMPRESSOR MOTOR	5
4M2	INLET GUIDE VANE FIRST STAGE ACTUATOR	131
4M3	OIL/REFRIGERANT PUMP MOTOR	165
4M4	INLET GUIDE VANE SECOND STAGE ACTUATOR	137
4M5	HOT GAS BY-PASS VALVE	210
4M12	FREE COOLING LIQUID LINE VALVE	214
4M13	FREE COOLING GAS LINE VALVE	217
4M1R2,3 & 4	MOTOR WINDING TEMPERATURE 1, 2 & 3	165
4R1	INBOARD BEARING TEMPERATURE SENSOR	146
4R2	OUTBOARD BEARING TEMPERATURE SENSOR	149
4R3	OIL PUMP DISCHARGE PRESSURE TRANSDUCER	153
4R4	OIL TANK PRESSURE TRANSDUCER	156
4R5	OIL TANK TEMPERATURE SENSOR	159
4R6	EVAPORATOR ENTERING WATER TEMPERATURE SENSOR	195
4R7	EVAPORATOR LEAVING WATER TEMPERATURE SENSOR	197
4R8	CONDENSER ENTERING WATER TEMPERATURE SENSOR	200
4R9	CONDENSER LEAVING WATER TEMPERATURE SENSOR	203
4R10	EVAP. SATURATED REF. TEMP. SENSOR	205
4R11	COND. SATURATED REF. TEMP. SENSOR	207
4R13	OUTDOOR AIR TEMPERATURE SENSOR	212
4R14	SECOND CONDENSER ENTERING WATER TEMP. SENSOR	215
4R15	SECOND CONDENSER LEAVING WATER TEMP. SENSOR	217
4R16	COMPRESSOR DISCHARGE REFRIGERANT TEMP. SENSOR	220
4R22	CONDENSER REFRIGERANT PRESSURE TRANSDUCER	222
4S1	HOT GAS BY-PASS END SWITCH	148
5K1	EVAPORATOR WATER PUMP CONTROL	194
5K2	CONDENSER WATER PUMP CONTROL	197
5K9	FREE COOLING INDICATOR	221
5H1	CHILLER LATCHING ALARM INDICATOR	269
5H2	CHILLER NON-LATCHING ALARM INDICATOR	275
5H4	PURGE ALARM INDICATOR	256
5H6	CHILLER RUNNING INDICATOR	266
5H7	CHILLER LIMIT MODE INDICATOR	272
5H8	ICE BUILDING INDICATOR	246
5H10	CHILLER HEAD RELIEF REQUEST INDICATOR	259
5H11	CHILLER MAXIMUM CAPACITY INDICATOR	262
5S1	EVAPORATOR WATER FLOW SWITCH	185
5S2	CONDENSER WATER FLOW SWITCH	186
5S3	EXTERNAL AUTO/ STOP	169
5S4	EMERGENCY STOP	171
5S5	EXTERNAL BASE LOADING E/D	251
5S6	EXTERNAL HOT WATER CONTROL E/D	253
5S7	EXTERNAL ICE BUILDING COMMAND	246
5S8	EXTERNAL FREE COOLING SWITCH	189





**Trane**  
**A business of American Standard Companies**  
**[www.trane.com](http://www.trane.com)**

For more information contact your local district office or e-mail us at [comfort@trane.com](mailto:comfort@trane.com)

Literature Order Number	CVHE-SVN03B-EN
File Number	SV-RF-CTV-CVHE-SVN03B-EN-0902
Supersedes	CVHE-SVN03A-EN-1001
Stocking Location	La Crosse

*Trane has a policy of continuous product and product data improvement and reserves the right to change design and specifications without notice.  
Only qualified technicians should perform the installation and servicing of equipment referred to in this publication.*