

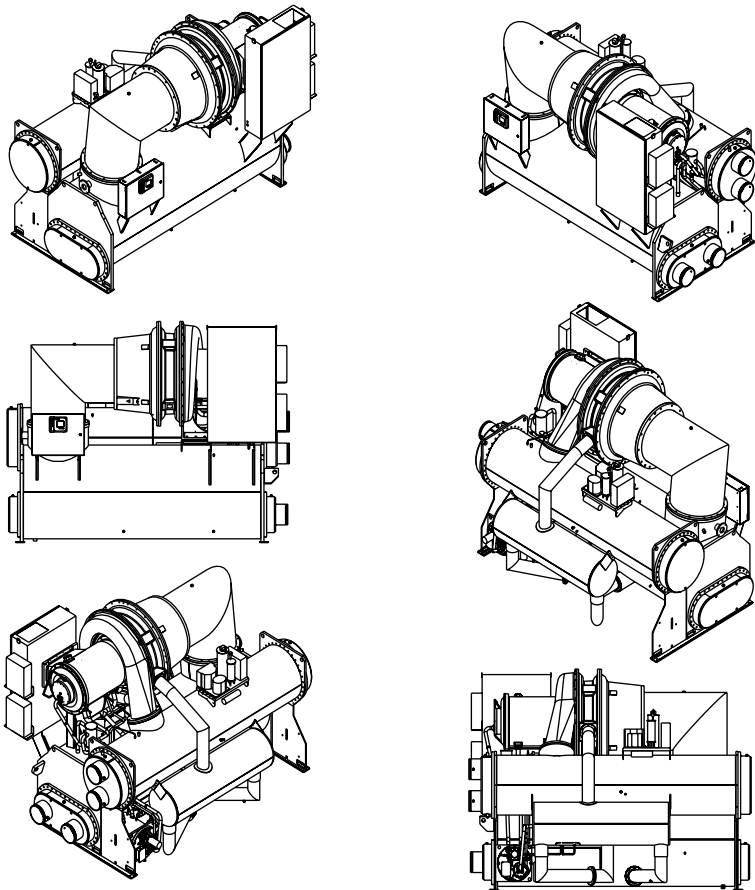

Installation – Piping Information

Water Cooled CenTraVac™ With CH530



Required Installation Information:

CVHE-SVN01A-EN – General Information

CVHE-SVN02A-EN – Piping Information

CVHE-SVN03A-EN – Electrical Information



Warnings and Cautions

Notice

Warnings and Cautions appear at appropriate locations throughout this manual.
Read these carefully.

Warning: Indicates a potentially hazardous situation which, if not avoided, could result in death or serious injury.

Caution: Indicates a potentially hazardous situation which, if not avoided, may result in minor or moderate injury. It may also be used to alert against unsafe practices and where property-damage-only accidents could occur.

Contents

Warnings and Cautions	2
Overview	5
Water Treatment	5
Pressure Gauges	5
Valves	5
Strainers	5
Flow-Sensing Devices	6
Evaporator and Condenser Water Piping	7
Water Box Locations	7
Water Piping Circuits	8
Water Piping Connections	10
Grooved Pipe Coupling	11
Flange-Connection Adapters	12
Victaulic Gasket Installation	12
Bolt-Tightening Sequence for Water Piping Connections	14
Evaporator Water Box Covers	14
EarthWise Purge Requirements	16
Refrigerant Vent-Line	17
Rupture Disc Vent Installation	17
Unit Insulation Requirements	22

Contents

Figures

Figure 1 – Flow Switch Installation	6
Figure 2 – Typical Evaporator Water Piping Circuit	8
Figure 3 – Typical Condenser Water Piping Circuits	9
Figure 4 – Typical CVHE Grooved Pipe Connection	10
Figure 5 – Customer Piping Alternatives for Water Connections	11
Figure 6 – Typical Shipping Location for Flange	12
Figure 7 – Typical Victaulic Flange Gasket Configuration	13
Figure 8 – Modifying 300 PSIG Flange Adapters for Flat-Faced Flange Application	13
Figure 9 – Bolt Tightening Sequences for Water Piping Flange and Water Boxes	15
Figure 10 – Rupture Disc Location, Cross Section of Rupture Disc and Recommended Rupture Disc Relief Piping	18
Figure 11 – Arrangement for Rupture Disc Relief Piping	19
Figure 12 – Rupture Disc Vent Pipe Sizing	21
Figure 13 – Recommended Areas for Unit Insulation	23

Tables

Table 1 – Evaporator Water Piping Connection Sizes	10
Table 2 – Condenser Water Piping Connection Sizes	10
Table 3 – Water Piping Connection Components	11
Table 4 – Installation Data for 150 PSIG Flange Adapters	13
Table 5 – Installation Data for 350 PSIG Flange Adapters	13
Table 6 – Flange Bolt Torque Recommendations for O-Ring and Flat-Gasket Piping Connections	14
Table 7 – “C” Values Used to Determine Rupture Disc Vent Line Sizes	20
Table 8 – Evaporator Insulation Requirements	22

Water Piping

Overview

Several water piping circuits must be installed and connected to the chiller.

Note: Field Piping must be arranged and supported to avoid stress on the equipment. It is strongly recommended that the piping contractor refrain from piping closer than 3' [.91 m] minimum to the equipment. This will allow for proper fit-up upon arrival of the unit at the job site. Any adjustment that is necessary can be made to the piping at that time.

- (a) Pipe the evaporator into the chilled water circuit;
- (b) Pipe the condenser into the condenser water circuit;
- (c) A heat-recovery condenser water circuit, (optional);
- (d) An auxiliary condenser water circuit, (optional)

Piping suggestions for each of the four water circuits listed above are outlined later in this section. General recommendations for the installation of field supplied piping components (e.g., valves, flow switches, etc.) common to most chiller water circuits are listed below.

Water Treatment

Since the use of untreated or improperly treated water in a CenTraVac™ may result in inefficient operation and possible tube damage, be sure to engage the services of a qualified water treatment specialist if needed. A label with the following disclaimer note is affixed to each unit.

Customer Note

The use of improperly treated or untreated water in this equipment may result in scaling, erosion, corrosion, algae or slime. The services of a qualified water treatment specialist should be engaged to determine what treatment, if any, is advisable. The Trane Company warranty specifically excludes liability for corrosion, erosion or deterioration of Trane equipment. Trane assumes no responsibilities for the results of the use of untreated or improperly treated water, or saline or brackish water.

CAUTION

DO NOT USE UNTREATED OR IMPROPERLY TREATED WATER. Failure to do so could result in equipment damage.

Pressure Gauges

Locate pressure gauge taps in a straight run of pipe. Place tap a minimum of one pipe diameter downstream of any elbow, orifice etc. Example, for a 6" [152 mm] pipe, the tap would be at least 6" [152 mm] from any elbow, orifice, etc.

Valves

1. Install field-supplied air vents and drain valves on the water boxes. Each water box is provided with a 3/4" [19 mm] National Pipe Thread Female (NPTF) vent and drain connection. Plastic plugs are factory-installed in both openings for shipment; remove and discard these plugs as you install the water box vents and drain valves.

2. If necessary for the application, install pressure-relief valves at the drain connections on the evaporator and condenser water boxes. To do so, add a tee with the relief valve attached to the drain valve.

To determine whether or not pressure relief valves are needed for a specific application, keep in mind that:

- (a) Vessels with close-coupled shutoff valves may cause high potentially damaging hydrostatic pressures as fluid temperature rises; and,
- (b) Relief valves are required by American Society of Mechanical Engineers (ASME) codes when the shell waterside is ASME. Follow ASME guidelines or other applicable codes to assure proper relief valve installation.

CAUTION

INSTALL PRESSURE-RELIEF VALVES IN THE CONDENSER AND EVAPORATOR WATER CIRCUITS, failure to do may result in shell damage due to hydrostatic expansion.

Strainers

Install a strainer in the entering side of each piping circuit to avoid possible tube plugging in the chiller with debris.

CAUTION

INSTALL STRAINERS IN ALL WATER PIPING ENTERING THE CHILLER, failure to do so may result in tube plugging conditions that could damage unit components.

Water Piping

Required Flow-Sensing Devices

Use either flow switches or differential pressure switches in conjunction with the pump interlocks to verify evaporator and condenser water flows.

To assure adequate chiller protection, wire the chilled-water and condenser-water flow switches in series with the appropriate water pump interlock. Refer to the wiring diagrams that shipped with the unit for specific electrical connections.

Unless stated otherwise, all flow sensing devices must be field supplied. Be sure to follow the manufacturer's recommendations for device selection and installation.

Also, review the general flow switch installation guidelines listed below.

1. Mount the flow switch upright in horizontal section of pipe. Allow at least five pipe diameters of straight, horizontal run on each side of the switch.
2. To assure that the flow switch operates as designed, adjust the length of the flow switch paddle to compensate for the pipe diameter and the height of the coupling tee used to install the switch.
3. Install the flow switch using a coupling that is large enough to allow the insertion of a bushing one pipe diameter larger than the flow switch base (Figure 1). This will prevent interference with the flow switch paddle.
4. Verify that the direction-of-flow arrow on the switch points in the same direction as actual water flow through the piping circuit.

5. Remove all air from the piping circuit to prevent possible flow switch "fluttering."
6. Adjust the flow switch to open when water flow is less than normal.

CAUTION

EVAPORATOR AND CONDENSER "PROOF OF FLOW" SWITCHES (EITHER FLOW OR DELTA-P) ARE REQUIRED IN SERIES WITH THE PUMP CONTACTOR AUXILIARY SHOWN ON WIRING DIAGRAMS.

THESE SWITCHES ARE USED WITH CONTROL LOGIC TO CONFIRM FLOW PRIOR TO STARTING A UNIT AND TO STOP A RUNNING UNIT IF FLOW IS LOST. FOR TROUBLE SHOOTING, A VIEWABLE DIAGNOSTIC IS GENERATED IF A "PROOF OF FLOW" SWITCH DOES NOT CLOSE WHEN FLOW IS REQUIRED. Failure to include the condenser "proof of flow" switch and "jumping out" this switch could cause the unit to stop on a secondary level of protection such as high condenser pressure. Frequent cycling on these higher level diagnostic devices could cause excessive thermal and pressure cycling of unit components (O-rings, gaskets, sensors, motors, controls, etc.) resulting in premature failure.

Figure 1 – Flow Switch Installation

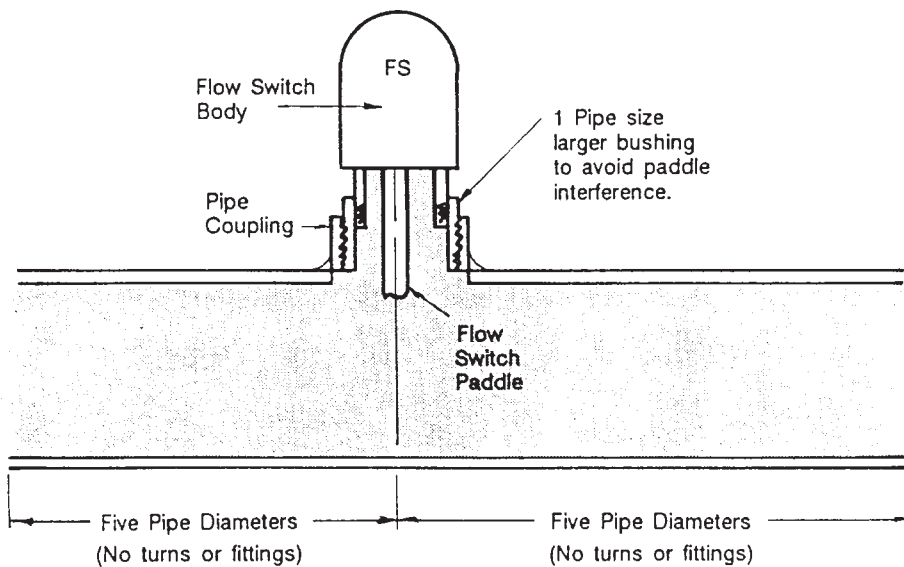

Water Piping

Evaporator and Condenser Water Piping

Figures 2 and 3 illustrate the typical water piping arrangements recommended for the evaporator and condenser.

Note: It is strongly recommended that the piping contractor refrain from piping closer than 3' [.91 m] minimum to the equipment. This will allow for proper fit-up upon arrival of the unit at the job site. Any adjustment that is necessary can be made to the piping at that time.

Water piping connection sizes are identified in Tables 1, 2 and 3. Remember that entering and leaving evaporator water can be piped to either water box connection since the tube bundles are split vertically.

Note: To assure that the evaporator water piping is clear, check it after the chilled water pump is operated but before initial chiller start-up. If any partial blockages exist, they can be detected and removed to prevent possible tube damage resulting from evaporator freeze-up or erosion.

Note: Arrange the condenser water piping so that the water supply enters the shell at the lower connection, and exits from the top connection. Single-pass condenser shells may be piped as desired since both connections are at the same level.

For applications that include an "infinite source" or "multiple-use", cooling condenser water supply, install a valved bypass "leg" (optional) between the supply and return pipes; see Figure 3. This valved bypass allows the operator to short-circuit water flow through the cooling condenser when the supply water temperature is too low.

CAUTION

SYSTEM PRESSURE DIFFERENTIAL MUST BE MAINTAINED ABOVE 5 PSID [34 kPa] AT ALL TIMES. Failure to do so could result in operating problems.

Note: Whenever a CVHE, CVHF and CVHG unit is equipped with an auxiliary condenser, use a bypass valve system to avoid circulating water through the auxiliary shell during unit shutdown.

Water Box Locations

If necessary, the non-marine-style water boxes on each shell whether evaporator or condenser can be switched end-for-end to obtain the desired piping arrangement. Contact Trane LBU Marketing for switching of marine-style boxes.

CAUTION

DO NOT EXCHANGE POSITIONS OF MARINE-STYLE WATER BOXES. Failure to follow this recommendation could alter designed water flow piping configuration and prevent proper unit operation.

To accommodate lifting apparatus, a nut is welded to each evaporator water box to enable attachment of a 3/4" [19 mm] eyebolt (field supplied). Condenser water boxes are provided with 1/2" [13 mm] tapped holes that allow installation of the eyebolt included in the unit's loose parts-box.

If the water boxes on any of the shells are exchanged end-for-end, be sure to reinstall them right side up to maintain the correct baffle arrangements. Use a new gasket with each water box cover.

Water Piping

Figure 2 – Typical Evaporator Water Piping Circuit

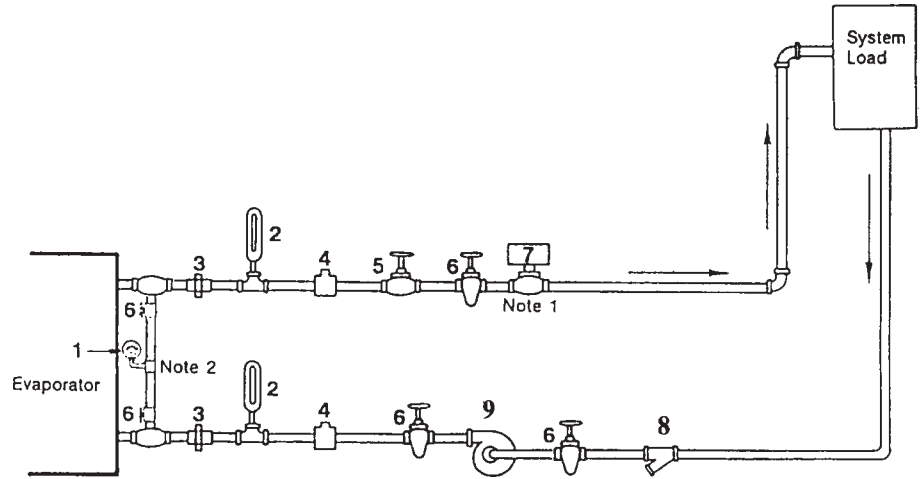

Notes:

1. Flow switch 5S1 (Item 7 in Legend of Components) may be installed in either the entering or leaving leg of the chilled water circuit.
2. It is recommended to pipe the (Item 1) gauge between entering and leaving pipes. A shutoff valve on each side of the gauge allows the operator to read either entering or leaving water pressure.

Legend of Field-Supplied and Installed Components

1. Pressure Gauge
2. Thermometer(s) (If field supplied)
3. Union(s) or Flanged Connection(s)
4. 1/2" [13 mm] NPT Couplings
5. Balancing Valve
6. Gate (Isolation) Valve(s) or Ball Valve(s)
7. Chilled Water Flow Switch (5S1)
8. Strainer
9. Evaporator Water Pump

Water Piping

Figure 3 – Typical Condenser Water Piping Circuits

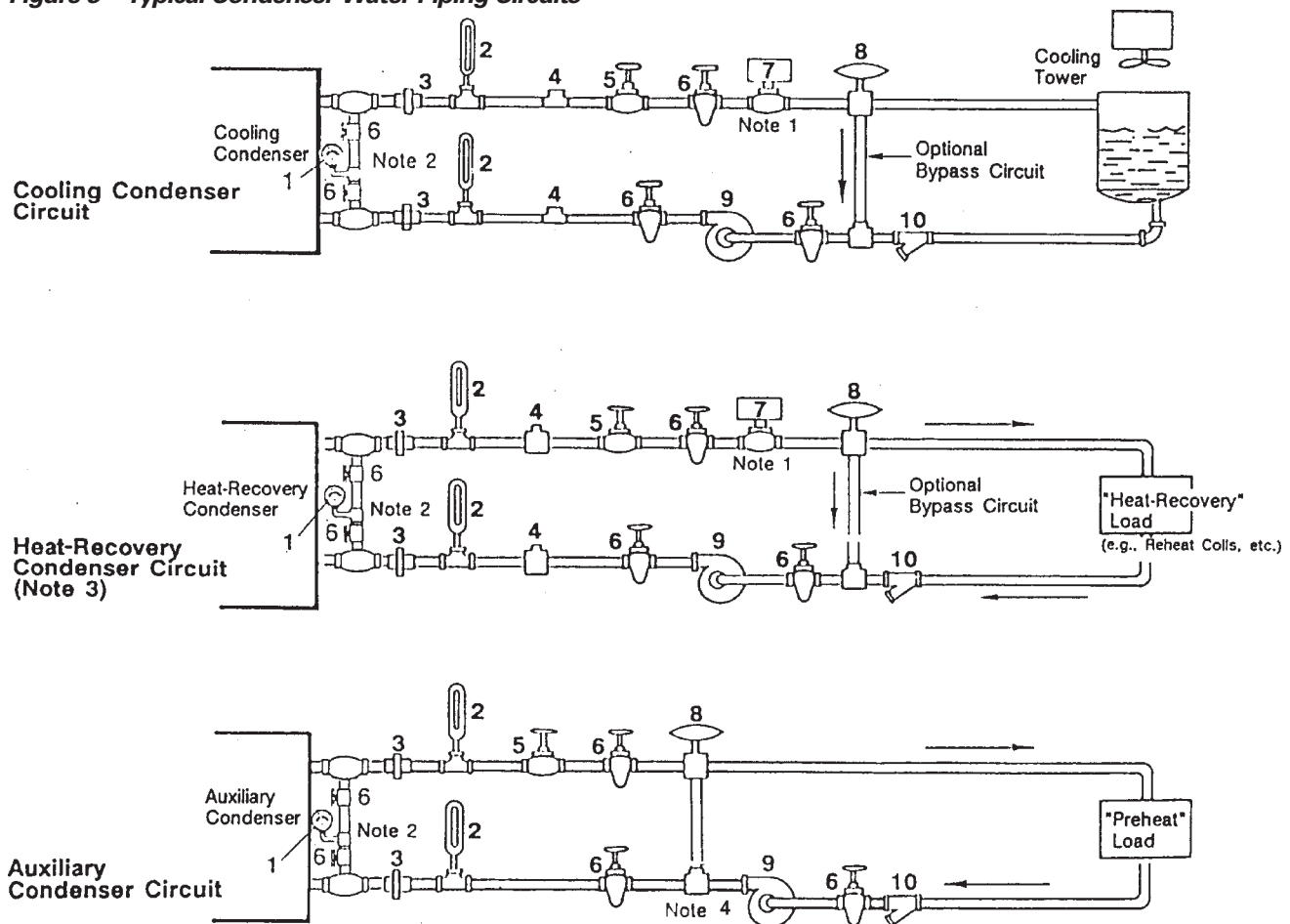

Notes:

1. The Flow Switch 5S2 (Item 7 in Legend of Components) may be installed in either the entering or leaving leg of the chilled water circuit.
2. It is recommended to pipe a single gauge between entering and leaving pipes.
3. Some type of field-supplied temperature control device may be required to regulate the temperature of the heat-recovery condenser water circuit. For application recommendations, see Trane Application Manual, "AM-FND-8", titled "Heat-Recovery Engineering Seminar".
4. Install a bypass valve system to avoid circulating water through the auxiliary shell when the unit is shut down.

Legend of Field-Supplied and Installed Components

1. Pressure Gauge
2. Thermometer(s) (If field supplied)
3. Union(s) or Flanged Connection(s)
4. 1/2" [13 mm] NPT Couplings
5. Balancing Valve
6. Gate (Isolation) Valve(s) or Ball Valve(s)
7. Condenser Water Flow Switch
8. 3-Way Valve (Optional)
9. Condenser Water Pump
10. Strainer

Water Piping

Water Piping Connections

For CVHEs beginning with design sequence "1D," all units (except those with 032 through 050 condenser shells with 150 psig [1035 kPa] non-marine water boxes) use cut-groove end NSP Victaulic style pipe connections. All CVHG's beginning with "1A" and later design sequences. All CVHF units, "A" and later design sequences, use grooved-pipe connections. See Figure 4.

Piping joined using grooved type couplings, like all types of piping systems, requires proper support to carry the weight of pipes and equipment. The support methods used must eliminate undue stresses on joints, piping and other components; allow movement where required, and provide for any other special requirements (i.e., drainage, etc.).

Table 1 – Evaporator Water Piping Connection Sizes

EVSZ	Nominal Pipe Size (inch/mm)					
	1 Pass		2 Pass		3 Pass	
	Inch	mm	Inch	mm	Inch	mm
032	8	219.1	6	168.3	5	141.3
050	10	273.0	8	219.1	6	168.3
080	12	323.4	10	273.0	8	219.1
142	16	406.4	12	323.9	10	273.0
210	16	406.4	14	355.6	12	323.9
250	16	406.4	14	355.6	12	323.9

Note: EVSZ = Evaporator Shell Size; S = Short Shell, L = Long Shell, E = Extended Shell

Table 2 – Condenser Water Piping Connection Sizes

CDSZ	Nominal Pipe Size (inch/mm)	
	2 Pass	
	Inch	mm
032	6	168.3
050	8	219.1
080	10	273.0
142	12	323.9
210	14	355.6
250	14	355.6

Note: CDSZ = Condenser Shell Size; S = Short Shell, L = Long Shell, E = Extended Shell

Figure 4 – Typical CVHE Grooved Pipe Connection

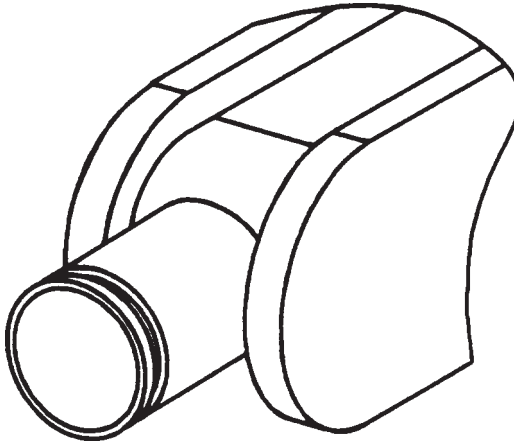

Water Piping

Table 3 – Water Piping Connection Components

Unit Model	Unit Connection Type	Customer Piping Connection	
		Victaulic™	Flanged
CVHE and CVHG	Flanged (Condenser 032-050 150 psig and 1035 kPa non-marine only)	Trane provided Victaulic-to-Flange Adapter	No Adapter Required
CVHE, CVHF and CVHG	Victaulic (All others)	Customer provided Victaulic Coupling	Trane provided Victaulic-to-Flange Adapter

Grooved Pipe Coupling

A customer-supplied, standard flexible grooved pipe coupling (Victaulic Style 77 or equivalent) should be used to complete the Victaulic connection for both 150 psig or 1035 kPa and 300 psig or 2068 kPa water boxes. See Table 3.

When a flexible coupling such as this is installed at the water box connections (Figure 5), other flexible piping connectors (i.e., braided-steel, elastomeric arch, etc.) are usually not required to attenuate vibration and/or prevent stress on the connections.

Note: Flexible coupling gaskets require proper lubrication before installation to provide a good seal. Refer to the coupling manufacturer’s guidelines for proper lubricant type and application.

Figure 5 – Customer Piping Alternatives for Water Connections

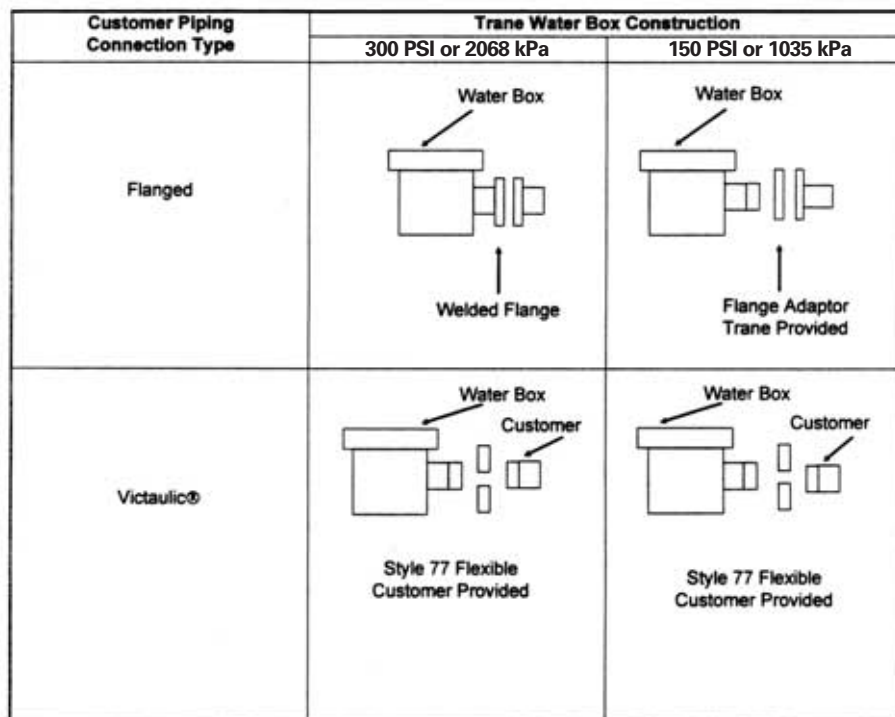

Water Piping

Flange-Connection Adapters

When flat-face flange connections are specified, flange-to-groove adapters are provided (Victaulic™ Style 741 for 150 psig or 1035 kPa systems; Style 743 for 300 psig or 2068 kPa systems). Welded flanged connections are available only as a design special unless ordered as such, flange to groove adapters are provided if flat faced flange connections are specified. The adapters are shipped bolted to one of the chiller end-supports (Figure 6). Adapter weights are given in Tables 1 and 2, The flange adapters provide a direct, rigid connection of flanged components to the grooved-pipe chiller water box connections,

In this case, the use of flexible type connectors (i.e., braided steel, elastomeric arch, etc.) is recommended to attenuate vibration and prevent stress at the water box connections. Flange adapters are not provided for CVHE/F/G units with 300 psig or 2068 kPa water boxes that have 14" [356 mm] or 16" [406 mm] piping connections.

All flange-to-flange assembly bolts must be provided by the installer. Bolt sizes and number required are given in Tables 1 and 2.

The four draw-bolts needed for the 14" [356 mm] and 16" [406 mm] Style 741 (150 psig or 1035 kPa) adapters are provided. The Style 741, 150 psig or 1035 kPa flange adapter requires a smooth, hard surface for a good seal.

Connection to other type flange faces (i.e., raised, serrated, rubber, etc.) will require the use of a flange washer between the faces. Refer to the flange adapter manufacturer's guidelines for specific information.

The Style 743, 300 psig or 2068 kPa flange adapters are designed to mate with raised-face flanges. They can be used with flat-faced flanges, however, if the raised projections on the outside face of the adapter are removed (Figure 8.)

Note: The flange-adapter gasket must be placed with the color-coded lip on the pipe and the other lip facing the mating flange.

CAUTION

GASKET-CONTACT SURFACES OF ADAPTER MUST BE FREE OF GOUGES, UNDULATIONS, OR DEFORMITIES. Failure to do so may not provide an effective seal.

Victaulic Gasket Installation

1. Check gasket and lubricate: Check gasket supplied to be certain it is suited for intended service. Code identifies gasket grade. Apply a thin coat of silicone lubricant to gasket tips and outside of gasket.

2. Install Gasket: Place gasket over pipe end, being sure gasket lip does not overhang pipe end. See Figure 7 for gasket configuration.
3. Join pipe ends: Align and bring two pipe ends together and slide gasket into position centered between the grooves on each pipe. No portion of the gasket should extend into the groove on either pipe.
4. Apply Vic-Flange™: Open fully and place hinged flange around the grooved pipe end with the circular key section locating into the groove.
5. Insert bolt: Insert a standard bolt through the mating holes of the Vic-Flange to secure the flange firmly in the groove.
6. Tighten nuts: Tighten nuts alternately and equally until housing bolt pads are firmly together (metal to metal). Excessive nut tightening is not necessary. **Note:** Uneven tightening may cause gasket to pinch.

Figure 6 – Typical Shipping Location for Flange

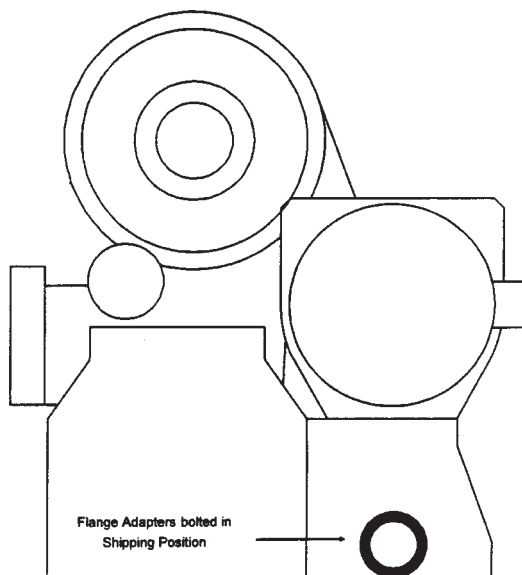

Water Piping

Figure 7 – Typical Victaulic Flange Gasket Configuration

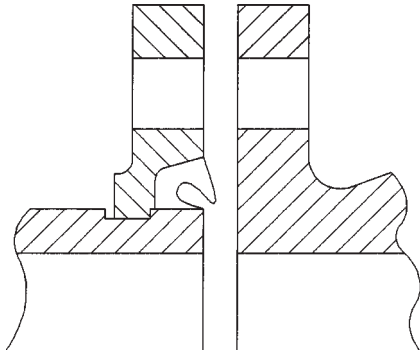

Figure 8 – Modifying 300 PSIG Flange Adaptors for Flat-Faced Flange Application

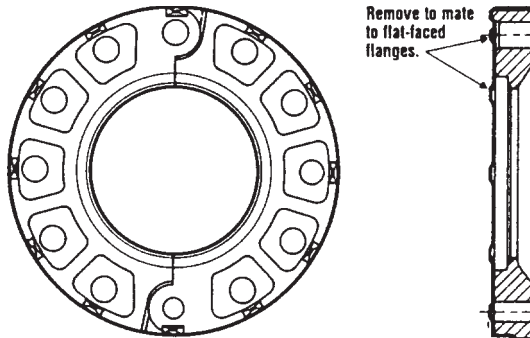

Table 4 – Installation Data for 150 PSIG Flange Adaptors (Style 741)

Nominal Pipe Size		Assembly Bolt Size*		Number of Assembly Bolts Required	Bolt Pattern Diameter		Weight	
Inch	mm	Inch	mm		Inch	mm	Pounds	kg
4	114.3	5/8 x 3	16 x 76	8	7.5	191	7.7	3.5
5	141.3	3/4 x 3-1/2	19 x 89	8	8.5	216	9.3	4.2
6	168.3	3/4 x 3-1/2	19 x 89	8	9.5	241	10.3	4.7
8	219.1	3/4 x 3-1/2	19 x 89	8	11.75	298	16.6	7.5
10	273.0	7/8 x 1/4	22 x 6	12	14.25	362	24.2	11.0
12	323.9	7/8 x 1/4	22 x 6	12	17	432	46.8	21.2
14	355.6	1 x 4-1/2	25 x 114	12	18.75	476	75	34.0
16	406.4	1 x 4-1/2	25 x 114	16	21.25	540	90	40.8

Table 5 – Installation Data for 350 PSIG Flange Adaptors (Style 743)

Nominal Pipe Size		Assembly Bolt Size*		Number of Assembly Bolts Required	Bolt Pattern Diameter		Weight	
Inch	mm	Inch	mm		Inch	mm	Pounds	kg
4	114.3	3/4 x 3-3/4	19 x 95	8	7.88	200	15.3	6.9
5	141.3	3/4 x 4	19 x 102	8	9.25	235	17.7	8.0
6	168.3	3/4 x 4-1/2	19 x 114	12	10.63	270	23.4	10.6
8	219.1	3/4 x 4-3/4	19 x 121	12	13	330	34.3	15.6
10	273.0	1 x 5-1/4	25 x 133	16	15.25	387	48.3	21.9
12	323.9	1-1/8 x 5-3/4	29 x 146	16	17.75	451	70.5	32.0

*Or equivalent supplied by others.

Water Piping

Bolt-Tightening Sequence for Water Piping Connections

A bolt-tightening sequence for flanges with flat gaskets or O-rings is described below and shown in Figure 9. Remember that improperly tightened flanges may leak.

Note: Before tightening any of the bolts, align the flanges. Flange bolt torque requirements are given in Table 6.

Flanges with 4, 8 or 12 Bolts

See Figure 9. Tighten all bolts to a snug tightness, following the appropriate numerical sequence for the flange. Repeat this sequence to apply the final torque to each bolt.

Flanges with 16, 20 or 24 Bolts

See Figure 9. Following the appropriate numbered sequence, tighten only the first half of the total number of bolts to a snug tightness. Next, sequentially tighten the remaining half of the bolts in the proper order.

Flanges with More than 24 Bolts

Refer to Figure 9 and sequentially tighten the first 12 bolts to a snug tightness. Tighten the next 12 consecutively numbered bolts in sequence, to the final torque.

Then, apply final torque to the first 12 bolts and the bolts not yet tightened (i.e., unnumbered bolts in Figure 9). Be sure to start with bolt "1" and move progressively around the flange in a clockwise direction.

Evaporator Water Box Covers

See Figure 9. Ensure that the water box head rests tightly against the tube sheet; then snugly tighten the 26 bolts in sequential order.

If excessive tube sheet crown prevents the head from contacting the tube sheet, tighten the bolts located where the greatest gaps occur. Be sure to use an equal number of bolt turns from side to side.

Table 6 – Flange Bolt Torque Recommendations for O-Ring and Flat-Gasket Piping Connections

Bolt Size		Gasket Type	
Inch	(mm)	O-Ring	Flat
3/8"	9.5	25 (34)	12-18 (16-24)
1/2"	13	70 (95)	33-50 (45-68)
5/8"	16	150 (203)	70-90 (95-122)
3/4"	19	250 (339)	105-155 (142-210)

Note: Torques provided in Ft/Lbs. (Newton/metres)

Water Piping

Figure 9 – Bolt Tightening Sequences for Water Piping Flanges and Water Boxes

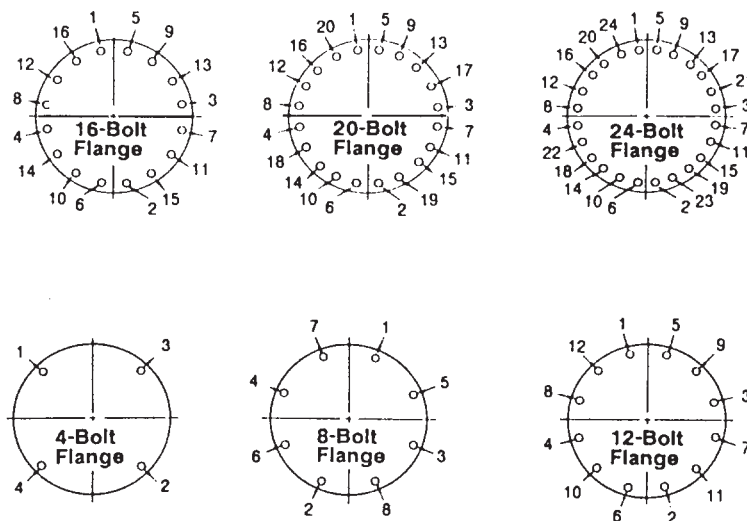

Flanges with more than 24 bolts

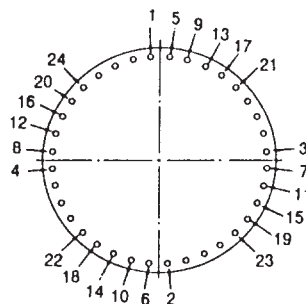

Evaporator Water Box Covers

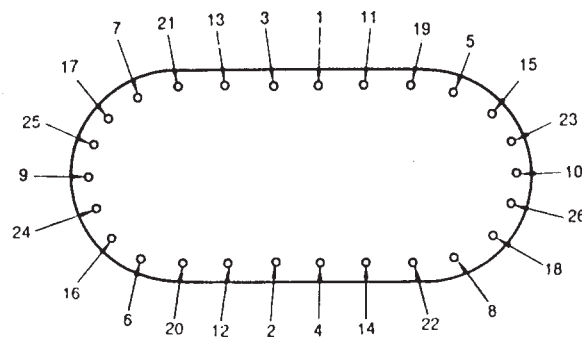

Purge Piping

EarthWise Purge Requirements Purge Installation

For certain CenTraVacs, the purge system is not mounted on the chiller when it ships. For 800-ton heat recovery chillers and 1250 and 1400 ton chillers with auxiliary condensers, the EarthWise Purge is shipped in a separate container that is secured to the chiller shipping skid.

Install the purge system in accordance with the following instructions.

1. Remove purge from its shipping brackets or container.
2. Disconnect purge gas and liquid lines and conduit from shipping bracket that spans purge supports on top of the heating or auxiliary condenser.
3. Remove shipping bracket and screws from purge supports and discard.
4. Locate purge on top of supports (purge base goes outside supports).
5. Secure the purge to the supports with the hardware provided.
6. Using proper brazing techniques as per American Welding society (A.W.S.) braze the following four copper lines at the factory disassembly points:
 - Purge suction line (larger)
 - Purge liquid drain line
 - Regeneration line
 - High pressure cutout switch

Note: Verify that the high-pressure cutout switch is connected to the line, which proceeds to the chiller condenser. (Check the copper tube routing to verify.)

- Assure braze joints are leak free
7. Remove purge panel cover and connect the unit wiring per the unit wiring diagrams:
 - Interprocessor communications bus (IPC).
 - Chiller motor temperature sensor wires to motor temperature module.
 - Conduit to control panel and interconnecting wires.
 - After inspection of terminations reassemble purge panel cover.
 8. With completion of brazing and electrical connections, the unit valves can be opened for unit operation.

Vent Piping

Refrigerant Vent-Line

General Recommendations

Both the purge and rupture disc vent lines must be routed to outside atmosphere. Use only material compatible with the refrigerant in use. The use of Poly Vinyl Chloride (PVC) (not Chlorinated Poly Vinyl Chloride (CPVC) piping is acceptable if the pipe joint is properly primed and if the adhesive used has been tested for refrigerant compatibility. Testing conducted in Trane laboratories has approved the use of the following materials for PVC pipe construction.

Primer - Hercules, PVC Primer #60-465, RectorSeal PVC Cleaner -Smiling Sam CL3 Adhesive-Hercules, Clear PVC, Medium Body, Medium Set, #60-020 RectorSeal PVC Cement-Green Gene 104.

Consult with the manufacturers of any field-provided components or materials added to the refrigerant-side of the machine for acceptable material compatibility.

During vent line construction, provide a drip leg on the line that is of sufficient length to accommodate a minimum of one gallon of liquid. Provide a standard capped refrigerant service valve to facilitate liquid removal. Accumulated liquid must be drained from the drip leg into an evacuated waste container once every six months, at a minimum, and more often if the purge operates excessively.

Purge Discharge Vent Line

On CVHE, CVHF and CVHG units, the purge discharge is factory-piped downstream of the rupture disc on the unit.

Rupture Disc Vent Installation

All CenTraVac™ chillers are equipped with carbon rupture discs. A cross-section of the rupture disc assembly appears in Figure 10 along with an illustration indicating the location of the rupture disc on the suction elbow.

If refrigerant pressure within the evaporator exceeds 15 psig, the rupture disc breaks, shell pressure is relieved as refrigerant escapes from the chiller.

When constructing the rupture disc vent line, be sure to consult local codes for applicable guidelines and constraints.

Several general recommendations for rupture disc vent line installation are outlined below.

1. Verify that the vacuum support side of the rupture disc is positioned as shown in the cross-section view that appears in Figure 10.

Note: If the rupture disc was removed for any reason, it must be reinstalled as shown.

2. Do not apply threading torque to the outside pipe assembly when installing the connecting pipe.

CAUTION

Do not apply threading torque to the outside pipe. Failure to do so may damage the rupture disc assembly.

3. Support the vent piping, use a flexible connection to avoid placing stress on the rupture disc. (Stress can alter rupture pressure and cause the disc to break prematurely.)

Vent Piping

The flexible connector used to isolate the rupture disc from excessive vent line vibration must be compatible with the refrigerant in use. Use a flexible, steel connector such as the stainless-steel type (from Vibration Mounting and Control, Inc.) or equivalent.

See Figure 11 for a recommended relief piping arrangement.

Important: Vent pipe size must conform to ANSI and ASHRAE Standard 15, which discusses vent pipe sizing.

Use Table 7 and then Figure 12 to determine proper vent pipe size.

Note: To determine the total "C" value for a specific unit, add the appropriate "C" values for the evaporator, standard condenser and economizer. If the unit is equipped with any options (e.g., heat recovery, free cooling, or an auxiliary condenser), add the applicable "C" value(s) to this total.

With this new sum, refer to Figure 12 to determine the vent line pipe diameter needed to handle flow.

4. Normally, where multiple chillers are used, install a separate rupture disc vent line for each unit.
5. Consult local regulations for any special relief line requirements and refer to Refrigerant Handling Guidelines.
6. The discharge of the vent line outside should not be in the general vicinity of any fresh air intakes to the building. Any gas venting from the vent line should not be allowed to re-enter the building.

Figure 10 – Illustrates Rupture Disc Location, Cross Section of Rupture Disc and Recommended Rupture Disc Relief Piping

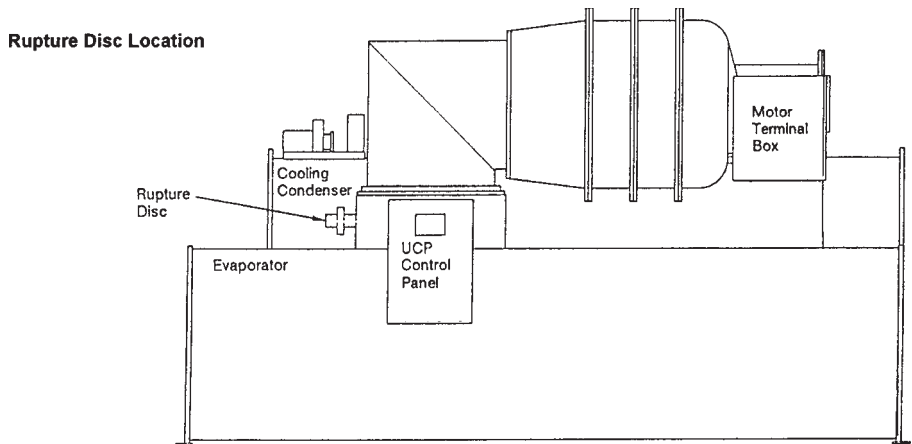

Cross Section of Rupture Disc

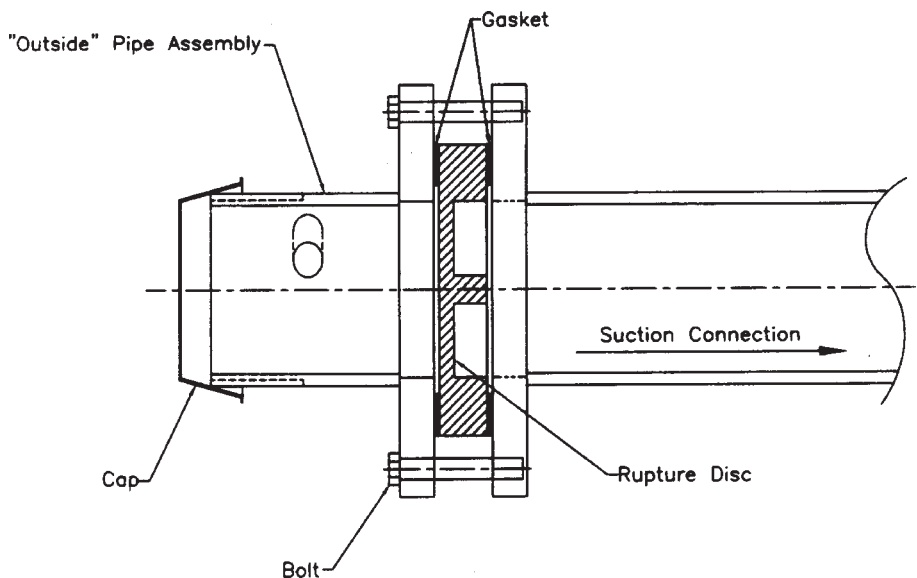

Vent Piping

Figure 11 – Arrangement for Rupture Disc Relief Piping

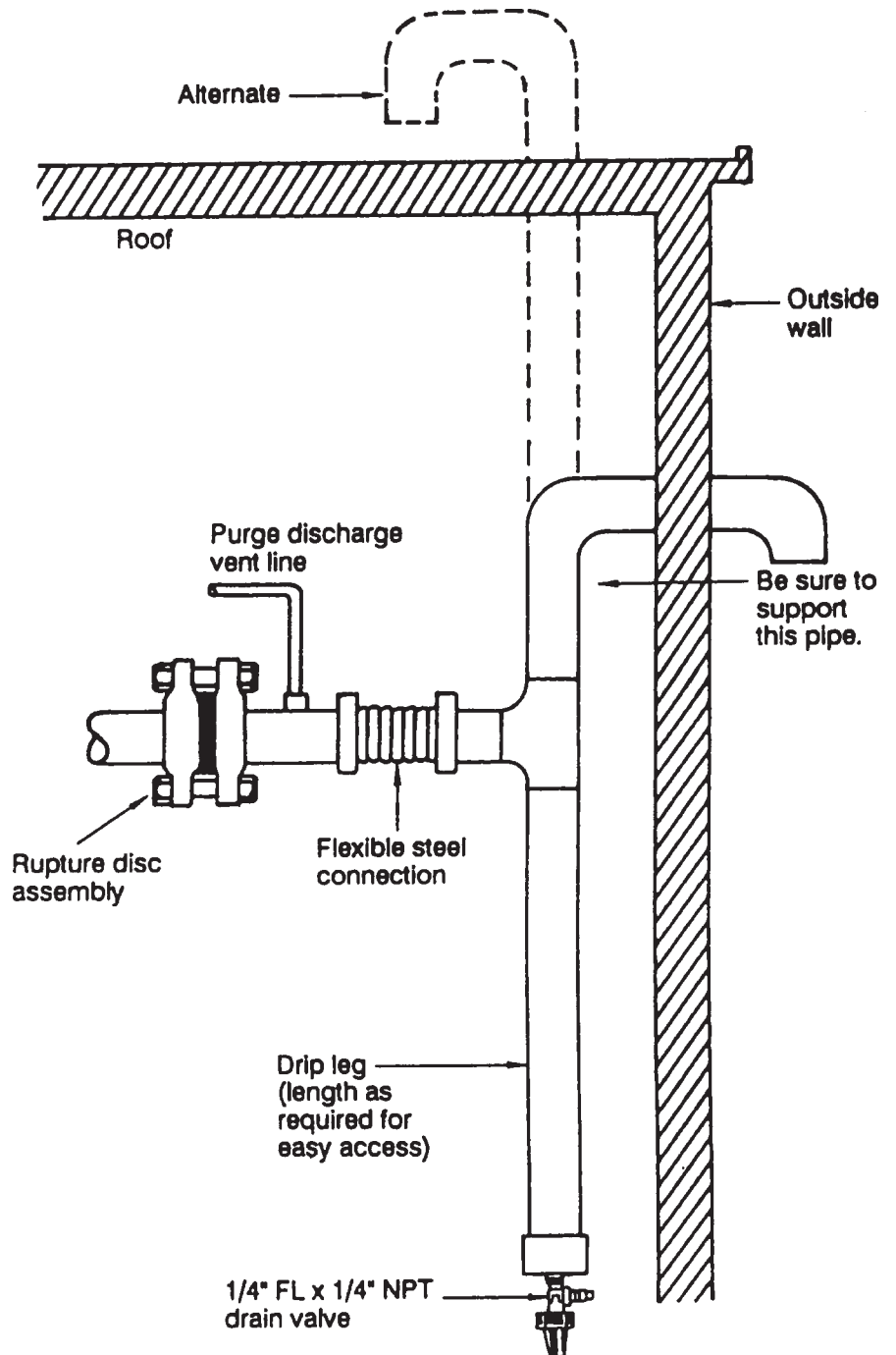



Vent Piping

Table 7 – “C” Values Used to Determine Rupture Disc Vent Line Sizes – CVHE, CVHF and CVHG

Evaporator Size (EVSZ) (3)	Condenser Size (CDSZ) (4)	“C” Values for Unit Components							
		Rupture Disc Diameter	Evaporator	Standard Condenser	Economizer	Short H.R. Condenser	Long H.R. Condenser	Auxiliary Condenser	With Free Cooling
032S	032S	3" (76 mm)	26.25	18.87					
032S	032L	3" (76 mm)	26.25	25.19	4.85	18.87	25.19	15.28	4.16
032L	032L	3" (76 mm)	35.04	25.19					
050S	050S	3" (76 mm)	33.05	23.56					
050S	050L	3" (76 mm)	33.05	31.45	7.44	23.56	31.45	15.28	6.16
050L	050L	3" (76 mm)	44.13	31.45					
080S	080S	3" (76 mm)	45.59	29.06					
080S	080L	3" (76 mm)	45.59	38.80	11.63	29.06	38.80	15.28	5.87
080L	080L	3" (76 mm)	60.86	38.80					
142E	142L	3" (76 mm)	74.30	50.50			Design Special		Design Special
142M	142L	3" (76 mm)	58.47	50.50					
142L	142L	3" (76 mm)	68.86	50.50	17.40	N/A*	50.50	15.28	7.10
210L	210L	3" (76 mm)	75.16	56.72			N/A*		
250E	250L	3" (76 mm)	93.81	62.12			56.72		

Notes:

- To determine the total “C” value for a specific unit, add the appropriate “C” values for the evaporator, standard condenser and economizer. If the unit is equipped with any options (e.g., heat recovery, free cooling or an auxiliary condenser, add the applicable “C” values to this total. With this new sum, refer to Figure 12 to determine the vent line pipe diameter.
- If piping multiple rupture discs (multiple units) to a common vent line, first determine the total “C” value for each unit, and then; add all “C” values together and apply the result to the “vent pipe sizing chart” in Figure 12.
- EVSZ = Evaporator Shell Size;
S = Short Shell
L = Long Shell
E = Extended Shell
M = Medium
- CDSZ = Condenser Shell Size;
S = Short Shell
L = Long Shell
E = Extended Shell

*N/A = Not Available

Vent Piping

Figure 12 – Rupture Disc Vent Pipe Sizing

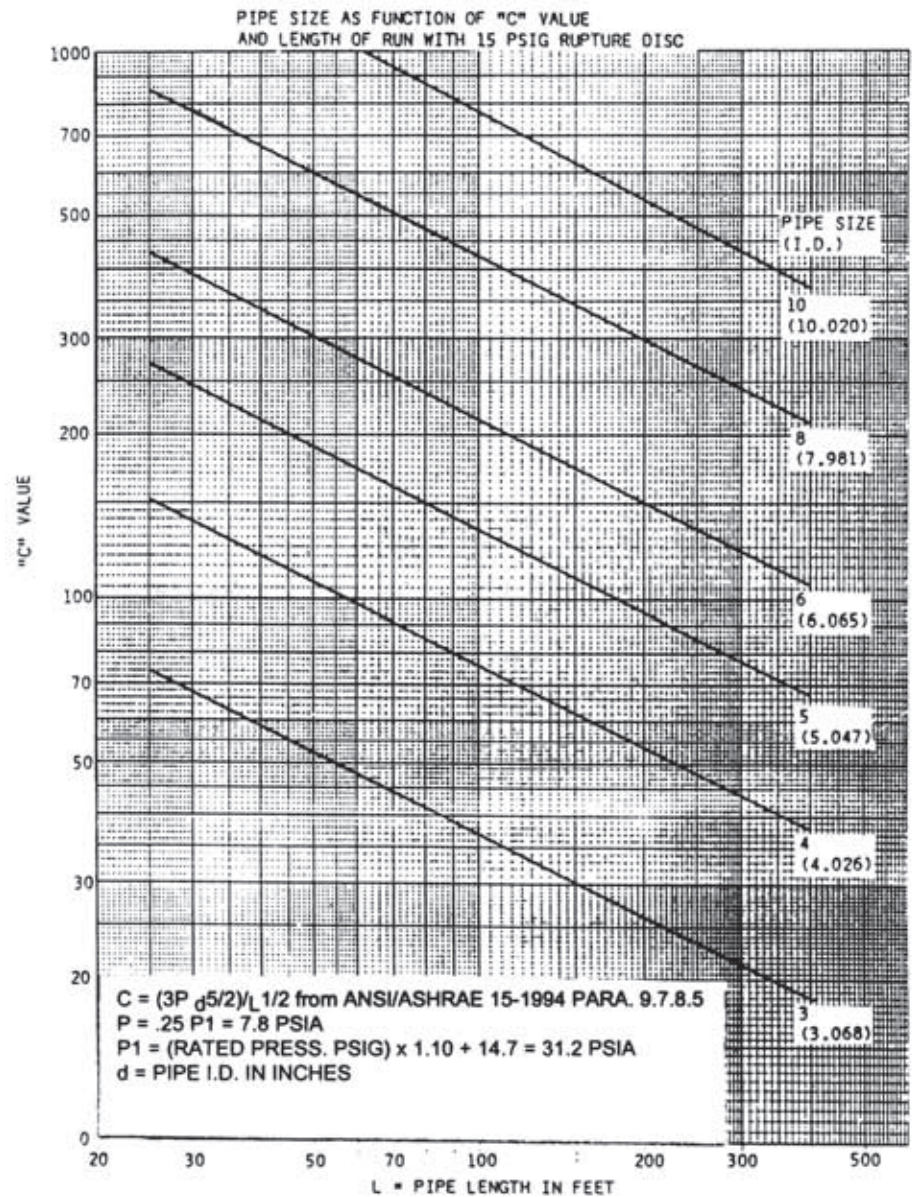



Insulation

Unit Insulation Requirements

Factory-installed insulation is available as an option for all CVHE, CVHF and CVHG units.

In those instances where the chiller is not factory-insulated, install insulation over the areas shaded in Figure 13. It may also be necessary to insulate the compressor suction cover and motor barrel if the unit is installed in an area subjected to high humidities.

Insulate both 1/4" [6.4 mm] eductor lines, one from the suction cover and one from the evaporator to prevent sweating.

The quantities of installation required based on unit size and insulation thickness are listed in Table 8. Insulation thickness is determined at normal design conditions which are:

- 85°
- 75% Relative Humidity

Note: If the unit is not factory-insulated: Install insulation around the evaporator bulbwells; and, ensure that the bulbwells and connections for the water box drains and vents are still accessible after insulation is applied.

Table 8 – CVHE, CVHF and CVHG Evaporator Insulation Requirements

EVSZ (Note 1)	Standard Unit		Free Cooling	
	3/4" [19 mm] Insulation (Note 2) (Square Feet)	3/8" [9.5 mm] Insulation (Note 3) (Square Feet)	3/4" [19 mm] Insulation (Note 2) (Square Feet)	3/8" [9.5 mm] Insulation (Note 3) (Square Feet)
032S	337	52	347	74
032L	365	52	377	74
050S	385	63	398	72
050L	420	63	436	72
080S	505	84	515	97
080L	553	84	566	97
142M	555	98	555	133
142L	578	98	578	133
142E	603	104	629	133
210L	700	98	710	133
210 D	1220	193	Not Available	Not Available
250 D	1308	193	Not Available	Not Available
250 E	770	97	Not Available	Not Available

Notes:

1. EVSZ = Evaporator Shell Size, L = Long Shell, S = Short Shell
2. D = Duplex, M = Medium, E = Extended
3. 3/4" [19 mm] sheet insulation is installed on the evaporator, evaporator water boxes, compressor motor, suction elbow and suction cover as indicated in Figure 13.
4. 3/8" [9.5 mm] sheet insulation is installed on all economizers. All liquid lines and other pipes require the use of 1/2" [13 mm] pipe insulation or 3/8" [9.5 mm] sheet insulation. Copper oil eductor tube lines require pipe insulation.
5. Refrigerant Pump units are NOT insulated on the motor or refrigerant drain lines.

CAUTION

TO PREVENT DAMAGE TO FACTORY-INSTALLED INSULATION, do not allow the insulation to be exposed to excessive sunlight. Failure to do so may damage insulation.

CAUTION

IF THE INSULATION WILL BE PAINTED IN THE FIELD, USE ONLY WATER-BASED LATEX PAINTS. Failure to do so results in damage because thinners and solvents used or other types of paints may cause seams in the insulation to open as a result of shrinkage.

Insulation

Figure 13 – Recommended Area for Unit Insulation

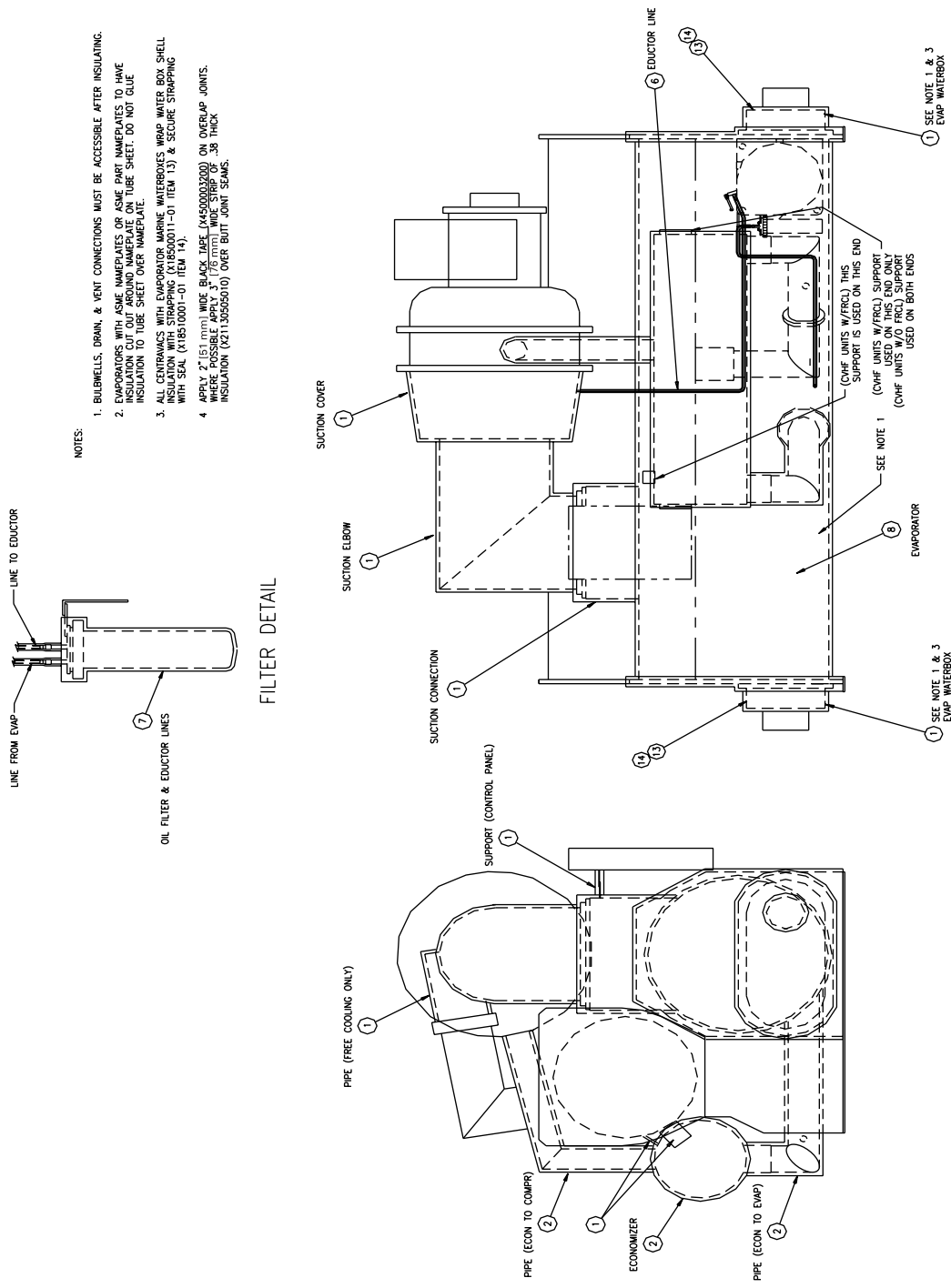



TRANE®

The Trane Company
An American Standard Company
www.trane.com

For more information contact
your local district office or
e-mail us at comfort@trane.com

Literature Order Number	CVHE-SVN02A-EN
File Number	SV-RF-CTV-CVHE-SVN02A-EN-1001
Supersedes	New
Stocking Location	La Crosse

Since The Trane Company has a policy of continuous product and product data improvement, it reserves the right to change design and specifications without notice.

Only qualified technicians should perform the installation and servicing of equipment referred to in this publication.