

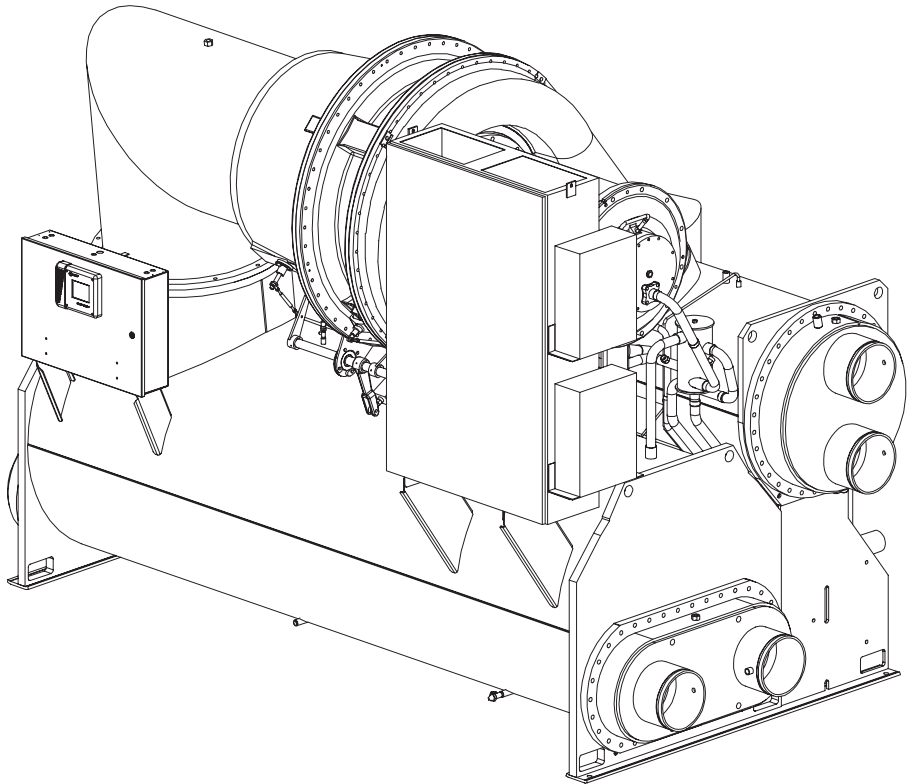

# Installation – General Information

---

## Water Cooled CenTraVac™ With CH530



**Required Installation Information:**

CVHE-SVN01C-EN – General Information

CVHE-SVN02D-EN – Piping Information

CVHE-SVN03C-EN – Electrical Information



# Warnings and Cautions

---

## Warnings and Cautions

Notice that warnings and cautions appear at appropriate intervals throughout this manual. Warnings are provided to alert installing contractors to potential hazards that could result in personal injury or

death, while cautions are designed to alert personnel to conditions that could result in equipment damage.

Your personal safety and the proper operation of this machine depend upon the strict observance of these precautions.

**NOTICE:** Warnings and Cautions appear at appropriate sections throughout this manual. Read these carefully.

**⚠ WARNING** – Indicates a potentially hazardous situation which, if not avoided, could result in death or serious injury.

**⚠ CAUTION** – Indicates a potentially hazardous situation which, if not avoided, may result in minor or moderate injury. It may also be used to alert against unsafe practices.

**CAUTION** – Indicates a situation that may result in equipment or property-damage-only accidents.

# Contents

---

<b>Warnings and Cautions</b>	<b>2</b>
<b>General Information</b>	<b>4</b>
<b>About This Manual</b>	<b>5</b>
<b>Product Description Block</b>	<b>5</b>
<b>Commonly Used Acronyms</b>	<b>5</b>
<b>Unit Nameplate</b>	<b>5</b>
<b>Metric Conversion</b>	<b>5</b>
<b>Responsibilities of Installing Contractor(s)</b>	<b>6</b>
<b>Unit Shipment</b>	<b>8</b>
<b>Storage</b>	<b>8</b>
<b>Recommended Unit Clearances</b>	<b>8</b>
<b>Operating Environment</b>	<b>9</b>
<b>Storage Requirements if Chiller is not installed</b>	<b>9</b>
<b>Foundation Requirements</b>	<b>10</b>
<b>Rigging</b>	<b>17</b>
<b>Chiller Isolation</b>	<b>20</b>
<b>Isolation Pads</b>	<b>20</b>
<b>Spring Isolators</b>	<b>23</b>
<b>Unit Leveling</b>	<b>27</b>

# Contents

---

## Figures

1 – Typical CVHE and CVHG Chiller with Refrigerant Pump .....	10
2 – Clearance Requirements for Cooling and Auxiliary Units .....	11
3 – Clearance Requirements for Heat Recovery .....	12
4 – Tube Bundle Locations Showing Cooling Only, Free Cooling, Heat Recovery, and Auxiliary Condenser .....	13
5 – Recommended Lifting Arrangements .....	18
6 – Isolation Pad .....	19
7 – Isolation Spring Placement .....	21
8 – Chiller Foot/Isolator Orientation .....	22
9 – Typical Spring Isolator Types and Construction .....	23
10 – Checking Unit Levelness .....	27

## Tables

1 – Installation Requirements .....	7
2 – Tube Bundle Locations for Cooling Only and Free Cooling Units .....	14
3 – Tube Locations for Heat Recovery and Auxiliary Condenser .....	14
4 – Typical Shipping and Operating Weights for Standard Options .....	14
5 – Typical Weights for Cooling Only .....	16
6 – Isolation Pad Loading .....	20

# General Information

---

## About this Manual

This manual describes proper installation of Model CVHE, CVHF, and CVHG 50 Hz and 60 Hz chillers with the Tracer CH530 Controls platform. See Figure 1 for an illustration of a Centrifugal Chiller with the Tracer CH530 Unit Control Panel.

These chillers are equipped with microcomputer-based control systems whether standard cooling or heat-recovery. A careful review of this information along with the submittal package provided for the unit will assure that the chiller is correctly installed.

## Product Description Block

Trane 50 Hz and 60 Hz hermetic CenTraVac units are defined by the product definition and selection system (PDS). Each unit is defined by the product description block which appears on the unit nameplate. A service model number which represents the unit as-built is provided on the unit nameplate, along with a specific unit service number. Both these are utilized whenever parts or service are required. An example is provided in the unit operation and maintenance manual (CVHE-SVU01A-EN).

## Commonly Used Acronyms

AFD = Adjustable Frequency Drive

ASME = American Society of Mechanical Engineers

ASHRAE = American Society of Heating, Refrigerating and Air Conditioning Engineers

BAS = Building Automation System

LBU = La Crosse Business Unit

CABS = Auxiliary Condenser Tube-Bundle Size

CDBS = Condenser Bundle Size

CESZ = Condenser Shell Size

CWR = Chilled Water Reset

DTFL = Delta-T at Full Load (i.e., the difference between entering and leaving chilled water temperatures at design load)

EVBS = Evaporator Size

EVSZ = Evaporator Shell Size

FC = Free Cooling

GPM = Gallons-per-Minute

HGBP = Hot Gas Bypass

HVAC = Heating, Ventilating and Air Conditioning

IE = Internally Enhanced Tubes

IPC = Interprocessor Communication

PFCC = Power Factor Correction Capacitor

PSID = Pounds-per-Square-Inch Differential

UCP = Chiller Control Panel

CH530 = Tracer CH530 Platform Unit Control Panel

## Unit Nameplate

The unit nameplate is located on the left side of the unit control panel (UCP). The following information is provided on the unit nameplate.

1. Unit model and size descriptor
2. Unit serial number
3. Identifies unit electrical requirements
4. Lists correct operating charge and type of refrigerant
5. Lists unit test pressures and maximum operating pressures
6. Identifies unit installation, operation and maintenance manuals
7. Product description block

## Metric Conversion

For tables and charts in this manual, the following conversions apply:

In.  $\times$  2.54 = cm

Ft.  $\times$  30.48 = cm

Lbs.  $\times$  .453 = kg

## General Information

---

### Responsibilities of Installing Contractor(s)

A list of the contractor responsibilities typically associated with the unit installation Process is provided below. Also see Table 1.

1. Locate and maintain the loose parts, i.e. isolators, bulb wells, temperature sensors, flow sensors or other factory-ordered field installed options, for installation as required. **Loose parts are located in the starter panel on units with factory-installed unit-mounted starters or in the motor terminal box for units with remote-mounted starters.**
2. Install unit on a foundation with flat support surfaces level within 1/16" and of sufficient strength to support concentrated loading.
3. Place manufacturer-supplied isolation pad assemblies under unit. (Use spring isolators for upper floor installations.)
4. Install unit per applicable Trane Installation Manual.
5. Complete all water piping and electrical connections  
**Note:** Field-piping must be arranged and supported to avoid stress on the equipment. It is strongly recommended that the piping contractor refrain from piping closer than 3'-0" [914 mm] minimum to the equipment. This will allow for proper fit-up on arrival of the unit at the job-site. Any adjustment that is necessary can be made to the piping at that time.
6. Where specified, supply and install valves in water piping upstream and downstream of evaporator and condenser water boxes to isolate shells for maintenance and to balance and trim system.
7. Supply and install flow switches (or equivalent devices) in both chilled water and condenser water piping. Interlock each switch with proper pump starter to ensure that unit can operate only when water flow is established.
8. Supply and install taps for thermometer and pressure gauges in water piping adjacent to inlet and outlet connections of both evaporator and condenser.
9. Supply and install drain valves to each water box.
10. Supply and install vent cocks on each water box.
11. Where specified, supply and install strainers ahead of all pumps and automatic modulating valves.
12. Supply and install pressure-relief piping from pressure-relief rupture disc to atmosphere.
13. If necessary, supply sufficient HCFC-22 refrigerant (maximum of 1 Lb. Per machine) for leak testing and dry nitrogen (8 psig [55 kPa] per machine) for pressure testing under manufacturer's supervision.
14. Start unit under supervision of a qualified service technician.
15. Where specified, supply and insulate evaporator and any other portions of machine as required to prevent sweating under normal operating conditions.
16. **Unit-Mounted Starters Only**  
Remove top of starter panel and cut access area for line-side wiring; front left quadrant of top provides recommended access to starter lugs.
17. Supply and install wire terminal lugs to starter.

18. **Unit-Mounted Starters Only**  
Supply and install field wiring to line-side lugs of starter.

### ASHRAE Standard 15 Compliance

Trane recommends that indoor CenTraVac® unit installations only be made in equipment or plant rooms that fully meet or exceed the guidelines of ASHRAE Standard 15, in addition to any applicable local, state, or national requirements. At a minimum this would typically include:

- The equipment room should have a refrigerant monitor or detector that is capable of monitoring and alarming within the acceptable exposure level of the refrigerant, and that can actuate mechanical ventilation.
- The equipment room should have an audible or visual alarm (other than the light on the monitor) that is controlled by the monitor. The alarm should annunciate inside of the equipment room and outside of each entrance to the equipment room.
- The equipment room should be properly vented to the outdoors, using mechanical ventilation that can be activated by the refrigerant monitor.
- The purge discharge and the rupture disk must be properly piped to the outdoors.
- If required by local or other codes, a self-contained breathing apparatus should be available in close proximity to the equipment room.

Refer to the latest copy of ASHRAE Standard 15 for specific guidelines. Trane assumes no responsibility for any economic, health, or environmental issues that may result from an equipment room's design or function.

## General Information

**Table 1. Installation requirements**

Type of Requirement	Trane-Supplied Trane-Installed	Trane-Supplied Field-Installed	Field-Supplied Field-Installed
Rigging			<ul style="list-style-type: none"> <li>A. Safety chains</li> <li>B. Clevis connectors</li> <li>C. Lifting beam</li> </ul>
Isolation		A. Isolation pads or spring isolators	A. Isolation pads or spring isolators
Electrical	<ul style="list-style-type: none"> <li>A. Circuit breakers or fusible disconnects (optional)</li> <li>B. Unit-mounted starter (optional)</li> <li>C. PFCCs (optional)</li> </ul>	<ul style="list-style-type: none"> <li>A. Jumper bars</li> <li>B. Temperature sensor (optional outdoor air)</li> <li>C. Flow switches (may be field supplied)</li> </ul>	<ul style="list-style-type: none"> <li>A. Circuit breakers or fusible disconnects (optional)</li> <li>B. Remote-mounted starter, AFD (optional)</li> <li>C. PFCCs (Remote-mounted starter option only)</li> <li>D. Terminal lugs</li> <li>E. Ground connection(s)</li> <li>F. Jumper bars</li> <li>G. BAS wiring (optional)</li> <li>H. IPC wiring (AFD and remote-mounted starters only)</li> <li>I. Control voltage wiring (AFD and remote-mounted starters only)</li> <li>J. Oil pump interlock wiring (AFD and remote-mounted starters only)</li> <li>K. High condenser pressure interlock wiring (AFD and remote-mounted starters only).</li> <li>L. Chilled water pump contactor and wiring</li> <li>M. Condenser water pump contactor and wiring</li> <li>N. Option relays and wiring (See Table 12)</li> </ul>
Water Piping		A. Flow switches (May be field supplied)	<ul style="list-style-type: none"> <li>A. Thermometers</li> <li>B. Water flow pressure gauges</li> <li>C. Isolation and balancing valves water piping</li> <li>D. Vents and drain valves (1 each per class)</li> <li>E. Pressure-relief valves (for water boxes as required)</li> </ul>
Rupture Disc	A. Rupture disc assy		A. Vent line and flexible connector
Insulation	A. Insulation (Optional)		A. Insulation



# General Information

## Unit Shipment

Each chiller ships from the factory as a hermetically-assembled package; it is factory-piped, wired and tested. All openings are covered or plugged to prevent contamination during shipment and handling.

See Figure 1 for an illustration of a typical chiller and its components. When the unit arrives at the job site, inspect it thoroughly for damage and material shortages. Suggested inspection steps below:

1. To prevent damaging moisture from entering the unit and causing corrosion, each chiller is pressurized with dry nitrogen before shipment.
2. Verify that the chiller is dehydrated by checking the evaporator press for an indication of holding charge pressure. Temporarily attach service gauge to refrigerant charging valves.  
**Note:** The holding charge should register approximately 5 psig [34.5 kPa] on the gauge at 72°F [22.2°C]. If the charge has escaped, contact your local Trane sales office for instructions.
3. The loose parts box and isolator pads ship in the motor terminal box or unit mounted starter enclosure if so equipped. Remove the sheet metal shipping bracket from the motor terminal box and discard.
4. Check the oil sump sight glasses to verify that the sump was factory-charged with 9 gallons [34 l] of oil on units with a Refrigerant Pump.

Beginning with design sequence 2K for the CVHE, L0 for the CVHG and U0 for the CVHF a new redesigned lubrication system has been incorporated. Aluminum balls, which are incorporated into the sight glass, float when oil is present, showing a better visible display of the oil level indication.

5. If no oil level indication is visible, contact your local Trane sales office.
6. Compare the unit nameplate data (including electrical characteristics) with the corresponding ordering and shipping information to verify that the correct unit was shipped to the job site.
7. If a thorough inspection of the chiller reveals damage or material shortages, be sure to file these claims with the carrier immediately. Specify the extent and type of damage found, and notify the appropriate Trane sales representative. Do not install a damaged unit without the sales representative's approval.

## Storage

If the chiller will be stored at the job site for an extended period of time before it is installed, exercise these precautionary measures to protect the unit from damage.

1. Do not remove the protective coverings factory-installed on the control panel and compressor inlet vane actuator for shipment.
2. Store the chiller in a dry, vibration free and secure area. If factory insulated, protect chiller from prolonged exposure to sunlight.

## CAUTION

### Insulation Damage!

**TO PREVENT DAMAGE TO THE FACTORY-INSTALLED INSULATION, do not allow excessive exposure to sunlight.**

3. Periodically check evaporator pressure to verify that 3 to 5 psig [21 to 34.5kPa] dry nitrogen @ 72°F [22.2°C] ambient holding charge is still in the chiller. If this charge escapes, contact a qualified service organization and the Trane sales engineer that handled the order.

**Note:** The storage for the microcomputer-based devices in the unit control panel is -40°F [-40°C] to 158°F [70°C].

### Recommended Unit Clearances

Adequate clearances around and above the chiller is required to allow sufficient access for service and maintenance operations.

Figures 2, 3, 4, 5 and 6 illustrate the recommended clearances for units with and without options.

**Note:** In each instance, the minimum vertical clearance above the chiller is 3 feet.

In addition, be sure to provide working space clearance in front of the unit control panel to satisfy national and local electric codes.

**Important:** Do NOT install piping or conduit above the compressor motor assembly or behind the suction elbow.

(Specific unit clearance requirements are also indicated in the submittal package provided for your unit.)

## General Information

---

### Operating Environment

Besides assuring that the site selected for chiller installation provides the necessary clearances, consider the equipment's operating environment.

To assure that electrical components operate properly, do not locate the chiller in an area exposed to dust, dirt, corrosive fumes, or excessive heat and humidity. Note that the maximum ambient temperature range for chiller operation is 100°F [38°C].

### CAUTION

### Electrical Component Damage!

**Chiller operation at ambient temperatures exceeding 100°F (38°C) may result in starter or electrical component damage. The higher ambient temperatures may affect the ability of panels to dissipate heat.**

**Take whatever action is necessary to improve the equipment room environment if any of these adverse operating conditions are present.**

### Storage Requirements if Chiller is not installed

1. Store the chiller in a dry, vibration free and secure area on a solid foundation. If the chiller has factory installed insulation, protect the chiller from direct sunlight. Do not remove any of the factory installed protective coverings.
2. Do not charge the chiller with refrigerant. If the refrigerant is at the site, follow the refrigerant manufacturer's instructions for refrigerant charge.
3. A dry nitrogen holding charge of 3 to 5 psig [21 to 34.5kPa] was installed at the factory. This positive pressure must be checked monthly to insure that moisture and non-condensibles do not get into the chiller. Check the pressure gauge on the evaporator shell to verify that the dry nitrogen holding charge is still in the chiller. If this charge had escaped, contact a qualified service organization to leak test and repair as necessary and also notify the Trane sales engineer that handled the order.
4. Do not operate the purge unit on the chiller.
5. The oil can be left in the chiller if an oil analysis is initially obtained after six months, and once each succeeding year. If no oil breakdown is evident you do not have to change oil. If breakdown is evident, the oil will need to be replaced. If an oil analysis program is not followed, discarded, and new oil installed just prior to start-up by a qualified service organization.
6. The water side of the chiller requires no special attention but there may be slight scale build-up inside the tubes. Tubes should be inspected and cleaned before the unit is placed into service.
7. If the motor sits for a long time, the bearings could take a set and cause bearing problems/ replacement later. Once every six months the chiller oil pump must be started and the compressor shaft rotated 450 degrees. Contact a qualified service organization to perform this task.
8. If the chiller is stored for more than five years, and the storage is expected to be indefinite, the chiller should be examined for leaks every five years from the initial storage date. Contact a qualified service organization to perform this task.
9. When the unit is to be installed, follow instruction manuals that were shipped with the chiller. The services of a qualified service organization should be obtained to conduct all activities associated with the start-up of a new chiller.

# General Information

*Figure 1. Typical chiller and its components*

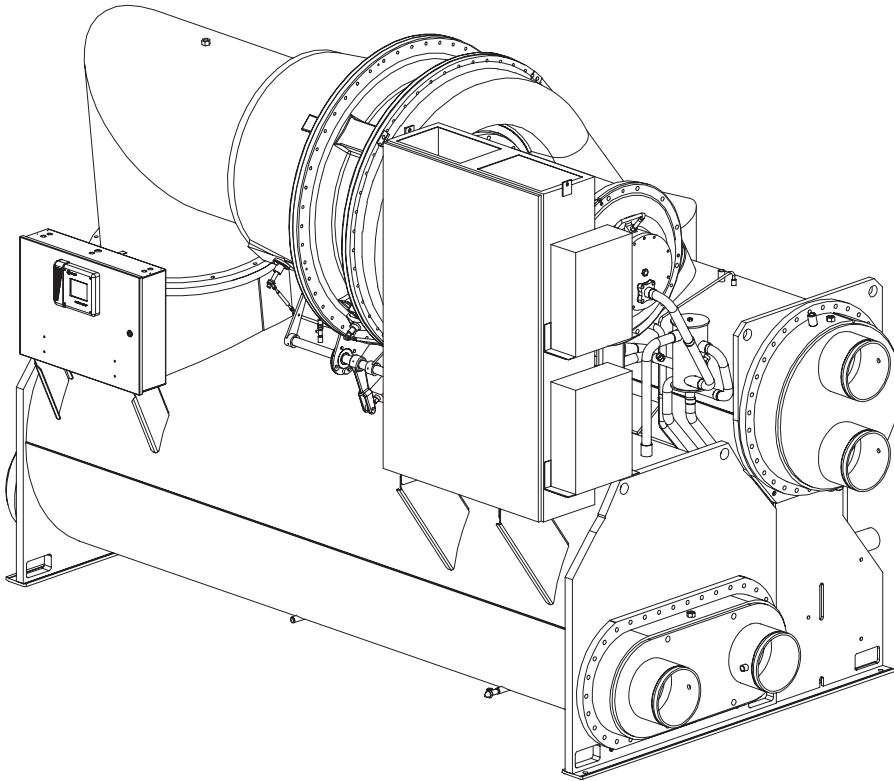

CVHF Shown from Right Front Angle View

## Foundation Requirements

Provide rigid, non-warping mounting pads or a concrete foundation as a mounting surface for the chiller. Ensure that the base is of sufficient strength and mass to properly support the chiller at its full operating weight (i.e., including completed piping, and full operating charges of refrigerant, oil and water.)

Table 2 and Table 3 give a summary of standard tube bundle locations. Table 4 indicates the weights of various chiller options. Table 5 shows typical weights for Cooling Only units.

Notice that the floor loading for all sizes of CVHE, CVHF and CVHG chillers is 50 pounds per square inch [344 kPa].

To assure proper unit operation, the chiller must be level within 1/16" [1.6 mm] over its length and width when set into place on the mounting surface.

The Trane Company will not assume responsibility for equipment problems resulting from an improperly designed or constructed foundation.

# General Information

**Figure 2. Clearance requirements for cooling and auxiliary units**

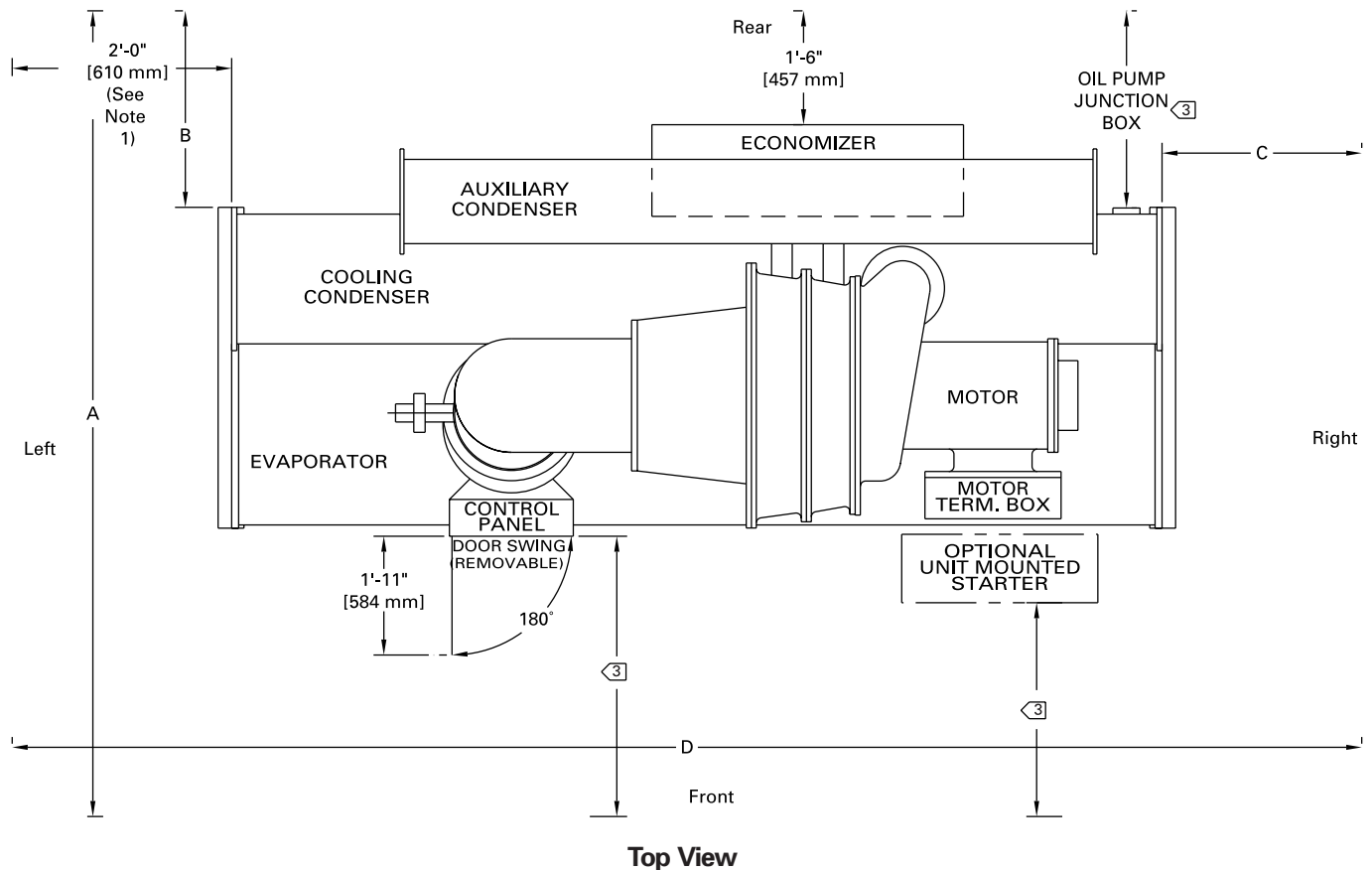

**Notes:**

- Does not include water box. Add water box dimension to this figure.
- Minimum vertical clearance over chiller is 3 feet.
- Minimum work space clearance per national and local electrical codes.

Do not install piping or conduit above compressor motor assembly or behind suction elbow.

**Table with Figure 2**

CVHE, F, G Cooling and Auxiliary Units (Clearance)													
DIM	SHELL COMB	EVSZ 032S/L		EVSZ 050S/L		EVSZ 080S/L		EVSZ 142M/L/E		EVSZ 210L		EVSZ 250E	
		(Inch)	[mm]	(Inch)	[mm]	(Inch)	[mm]	(Inch)	[mm]	(Inch)	[mm]	(Inch)	[mm]
A1	ALL	10'-3-1/4"	3131	11'-1-5/8"	3393	12'-5-1/4"	3790	14'-5-3/4"	4413	15'-3-3/4"	4667	16'-5-1/2"	5017
A2	ALL	11'-4-1/2"	3466	12'-5-1/2"	3797	13'-1-5/8"	4003	15'-1"	4597	15'-7"	4750	16'-6-1/2"	5042
B	ALL	2'-6-5/8"	777	2'-10"	864	2'-6-3/8"	772	2'-11-3/8"	899	3'-0-1/8"	918	2'-11-1/8"	893
	S/S	11'-9"	3581	11'-9"	3581	11'-9"	3581	N/A	N/A	N/A	N/A	N/A	N/A
C	S/L, M/L, LL	15'-6"	4724	15'-6"	4724	15'-6"	4724	15'-6"	4724	15'-6"	4724	N/A	N/A
	E/L	N/A	N/A	N/A	N/A	N/A	N/A	17'-5"	5309	N/A	N/A	17'-5"	5309
D	S/S	26'-5"	8052	26'-6-3/8"	8087	27'-4-1/4"	8338	N/A	N/A	N/A	N/A	N/A	N/A
	S/L, M/L, L/L	33'-11-1/4"	10343	34'	10363	34'-10-1/2"	10640	35'-5-1/4"	10801	35'-5-1/4"	10801	N/A	N/A
	E/L	N/A	N/A	N/A	N/A	N/A	N/A	39'-3"	11963	N/A	N/A	39'-6"	12039

A1 = Without Unit Mounted Starter  
A2 = With Unit Mounted Starter

**Notes:**

- EVSZ = Evaporator Size, L = Long Shell; S = Short Shell; E = Extended Shell, M = Medium Shell
- Clearance requirement to evaporator tube removal does not include water box. Add water box dimension to this figure.

# General Information

Figure 3. Clearance requirements for heat recovery units

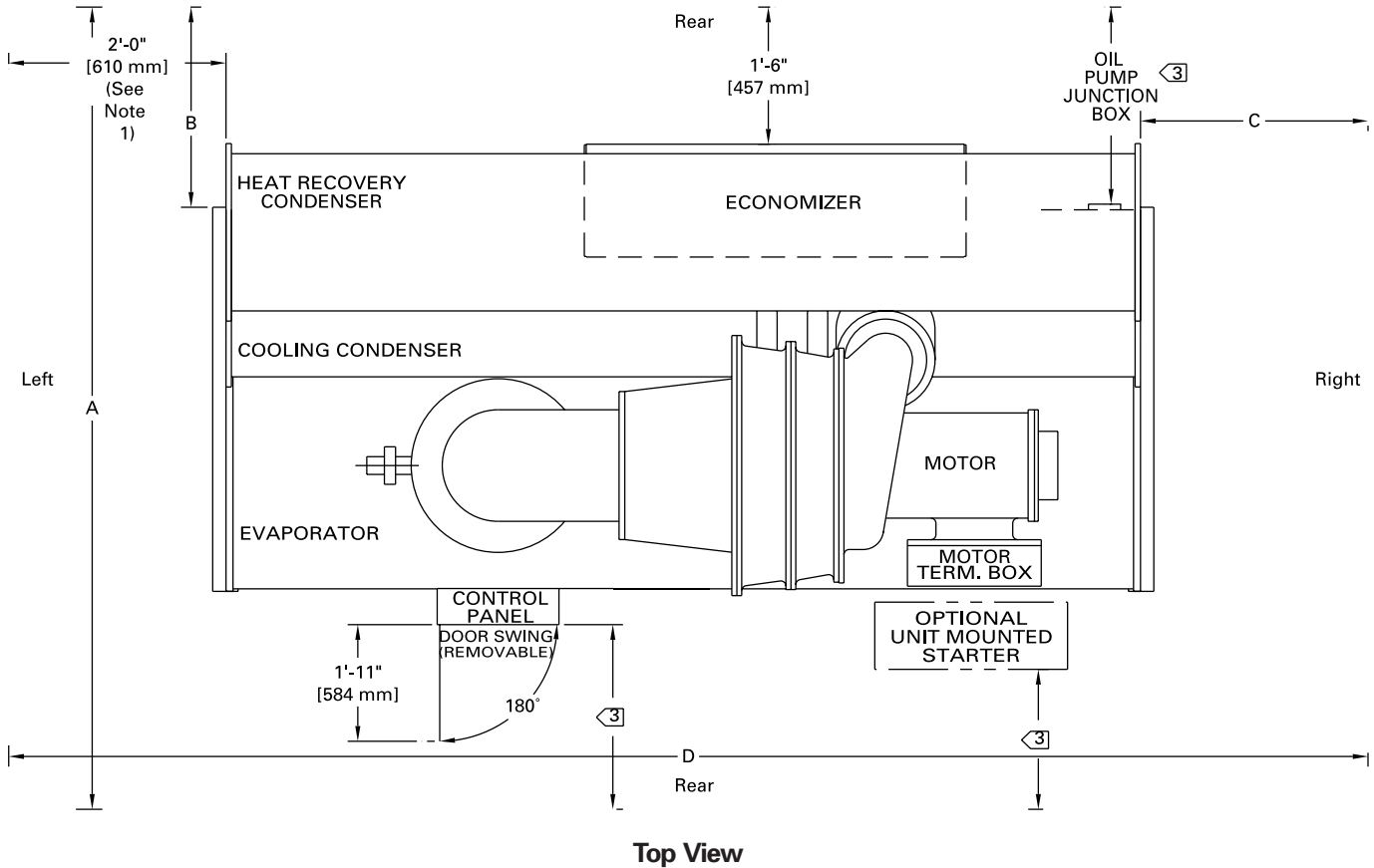

- Notes:**
1. Does not include water box.
  2. Minimum vertical clearance over chiller is 3 feet.
  3. Minimum work space clearance per national and local electrical codes.

Do not install piping or conduit above compressor motor assembly or behind suction elbow.

Table with Figure 3

CVHE, F, G Cooling and Auxiliary Units (Clearance)													
DIM	SHELL COMB	EVSZ 032S/L		EVSZ 050S/L		EVSZ 080S/L		EVSZ 142M/L/E		EVSZ 210L		EVSZ 250E	
		(Inch)	[mm]	(Inch)	[mm]	(Inch)	[mm]	(Inch)	[mm]	(Inch)	[mm]	(Inch)	[mm]
A1	All	10'-6-5/8"	3216	11'-2-3/4"	3422	12'-5-3/8"	3794	14'-10"	4521	15'-8-1/2"	4788	N/A	N/A
A2	All	11'-8"	3555	12'-6-5/8"	3825	13'-1-3/4"	4006	15'-5-1/4"	4705	15'-11-3/4"	4870	N/A	N/A
B	All	2'-10"	864	2'-11-1/8"	893	2'-6-1/2"	775	3'-3-5/8"	1006	3'-10-1/4"	1174	N/A	N/A
C	S/S	11'-9"	3581	11'-9"	3581	11'-9"	3581	N/A	N/A	N/A	N/A	N/A	N/A
	S/L, M/L, L/L	15'-6"	4724	15'-6"	4724	15'-6"	4724	15'-6"	4724	15'-6"	4724	N/A	N/A
	E/L	N/A	N/A	N/A	N/A	N/A	N/A	17'-5"	5309	N/A	N/A	N/A	N/A
D	S/S	26'-5"	8052	26'-6-3/8"	8087	27'-4-1/4"	8338	N/A	N/A	N/A	N/A	N/A	N/A
	S/L, M/L, L/L	33'-11-1/4"	10343	34'	10363	34'-10-1/2"	10630	35'-5-1/4"	10801	35'-5-1/4"	10801	N/A	N/A
	E/L	N/A	N/A	N/A	N/A	N/A	N/A	39'-3"	11963	N/A	N/A	N/A	N/A

A1 = Without Unit Mounted Starter  
A2 = With Unit Mounted Starter

**Notes:**

1. EVSZ = Evaporator Size, L = Long Shell; S = Short Shell; E = Extended Shell
2. Clearance requirement to evaporator tube removal does not include water box. Add water box dimension in this figure.
3. Does not include water box. Add water box dimension to this figure.

# General Information

Figure 4. Tube bundle locations showing cooling only, free cooling and heat recovery and auxiliary condenser units

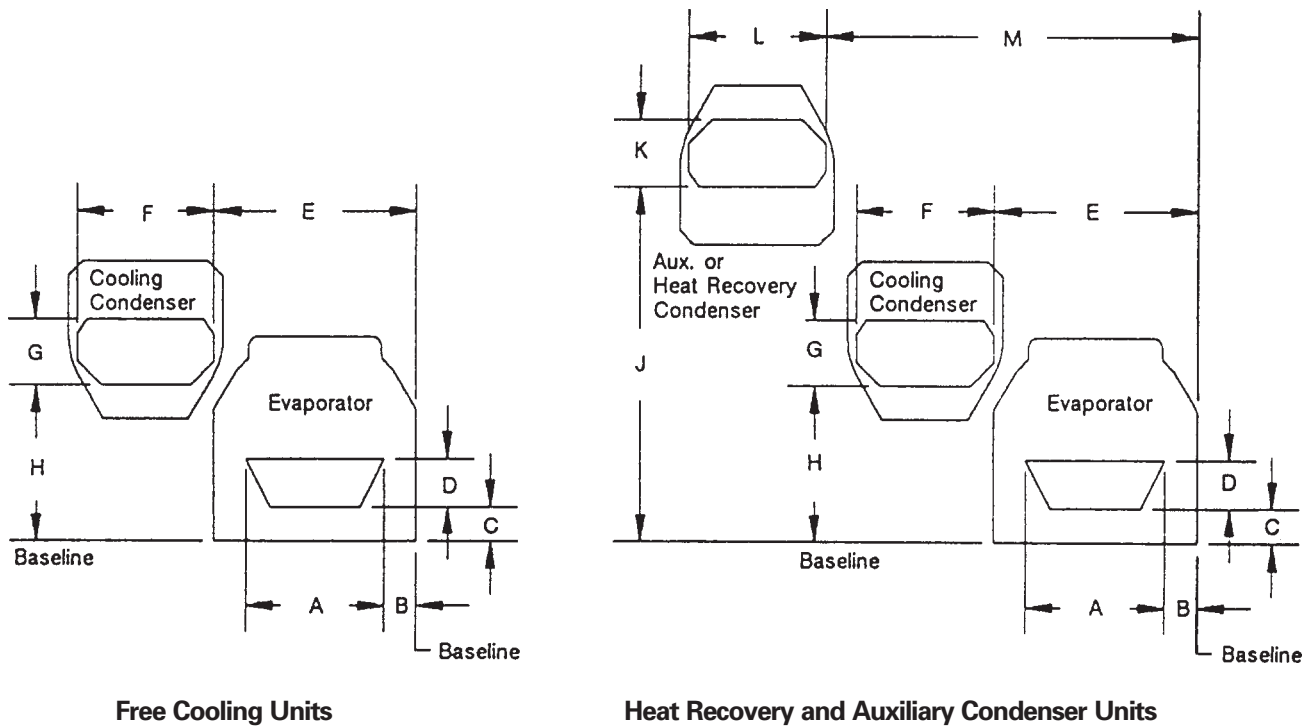



# General Information

# IP Units

**Table 2. Tube bundle locations for cooling only and free cooling units (inches)**

Shell Size	Cooling Only and Free Cooling Units							
	A	B	C	D	E	F	G	H
032	2'-0-3/4"	2-5/8"	11-1/8"	7-1/4"	2'-7-3/4"	18"	10"	2'-2-3/8"
050	2'-6-3/4"	2-7/8"	9-3/8"	9-5/8"	3'-1-1/8"	1'-11-1/8"	1'-2-3/8"	2'-3-3/4"
080	3'-5-1/8"	4-1/4"	6-1/4"	11-3/8"	3'-7-3/4"	2'-4-1/8"	1'-7-1/4"	3'-7"
142	3'-10-3/8"	4-1/4"	6-5/8"	1'-2-5/8"	4'-2-3/8"	3'-3-1/8"	2'-0-7/8"	3'-8-3/8"
210	4'-5"	4-1/2"	7-1/8"	1'-5"	4'-11"	3'-7-1/2"	2'-4-1/8"	3'-9-3/4"
250	5'-0-3/4"	5-1/2"	7-1/8"	1'-7-1/4"	5'-8-5/8"	3'-10-3/4"	2'-4-1/8"	4'-0-1/4"

**Table 3. Tube locations for heat recovery and auxiliary condenser units (inches)**

Shell Size	Heat Recovery				Auxiliary Condenser			
	J	K	L	M	J	K	L	M
032	4'-6-3/8"	10-1/4"	1'-6-1/2"	4'	4'-6-3/4"	9-1/8"	1'-2"	3'-11-3/4"
CVHE 050	5'-2-3/8"	1'-2-3/8"	1'-10-3/8"	4'-6"	5'-0-7/8"	9-1/8"	1'-2"	4'-8-1/4"
CVHEF/G 050	6'-2-1/2"	1'-2-3/8"	1'-10-3/8"	4'-10"	6'-0-7/8"	9-1/8"	1'-2"	5'-0-5/8"
080	T-3-1/8"	1'-7-1/4"	2'-4-7/8"	4'-8-3/8"	6'-10-1/2"	9-1/8"	1'-2"	5'-8-7/8"
142	8'-7-3/8"	2'-0-7/8"	3'-2-1/2"	6'-2"	7'-9-3/8"	9-1/8"	1'-2"	7'-3-5/8"
210	8'-7-1/2"	2'-4-1/8"	3'-7-1/2"	6'-6-5/8"	8'-7-5/8"	9-1/8"	1'-2"	3'-9-3/4"
250	Not Available							

**Table 4. Typical shipping and operating weights (lbs.) (see note 1)**

Cond Size CDSZ	Aux Cond Size 80		Aux Cond Size 130		Heat Rec Cond		Free Cooling	
	Ship	Oper	Ship	Oper	Ship	Oper	Ship	Oper
032S	825	1057	960	1248	2119	2624	500	785
032L	825	1057	960	1248	2663	3263	500	785
050S	825	1057	960	1248	3170	4018	750	1290
050L	825	1057	960	1248	3985	4986	750	1290
080S	825	1057	960	1248	5340	6593	750	1360
080L	825	1057	960	1248	6683	8180	750	1360
142L	825	1057	960	1248	12180	14666	1400	2400
210L	825	1057	960	1248	16023	19299	1400	2400

**Notes:**

1. Unit-Mounted Starter Option = 530 Lbs. (Shipping and Operating)
2. Weights shown are accurate within ± 3% and are calculated with non-marine 150 psig water boxes. Marine-style water boxes may add considerably more weight; contact LBU Marketing for details.
3. Operating weights include refrigerant, oil and water charges.
4. For more specific data on weights and isolator loading, refer to the unit submittal package.

# General Information

## SI Units

**Table 2. Tube bundle locations for cooling only and free cooling units (mm)**

Shell Size	Cooling Only and Free Cooling Units							
	A	B	C	D	E	F	G	H
32	629	67	283	184	813	457	254	670
50	781	73	238	244	943	588	365	705
80	1044	108	159	289	1111	715	489	1095
142	1178	108	168	677	1279	993	632	1127
210	1346	114	181	432	1498	1105	715	1162
250	1543	140	181	489	1743	1187	715	1225

**Table 3. Tube locations for heat recovery and auxiliary condenser units (mm)**

Shell Size	Heat Recovery				Auxiliary Condenser			
	J	K	L	M	J	K	L	M
32	1381	260	470	1219	1390	232	356	1212
CVHE 50	1584	365	568	1371	1546	232	356	1429
CVHEF/G 50	1893	365	568	1473	1852	232	356	1540
80	2213	489	734	1432	2096	232	356	1749
142	2625	632	978	1880	2372	232	356	2226
210	2629	715	1108	1997	2632	232	356	1162
250	Not Available							

**Table 4. Typical shipping and operating weights (k) (see note 1)**

Cond Size CDSZ	Aux Cond Size 80		Aux Cond Size 130		Heat Rec Cond		Free Cooling	
	Ship	Oper	Ship	Oper	Ship	Oper	Ship	Oper
032S	374	479	435	566	961	1190	227	356
032L	374	479	435	566	1208	1480	227	356
050S	374	479	435	566	1438	1823	340	585
050L	374	479	435	566	1808	2262	340	585
080S	374	479	435	566	2422	2991	340	617
080L	374	479	435	566	3031	3710	340	617
142L	374	479	435	566	5525	6652	635	1089
210L	374	479	435	566	7268	8754	635	1089

**Notes:**

- Unit-Mounted Starter Option = 236 Kg (Shipping and Operating)
- Weights shown are accurate within  $\pm 3\%$  and are calculated with non-marine 1034 kPa water boxes. Marine-style water boxes may add considerably more weight; contact LBU Marketing for details.
- Operating weights include refrigerant, oil and water charges.
- For more specific data on weights and isolator loading, refer to the unit submittal package.



# General Information

**Table 5. Typical weights for cooling only**

Type	Nton	Shell Length Designators		Maximum Weights (Lbs)		Maximum Weights (Kg)	
		EVSZ	CDSZ	Shipping	Operating	Shipping	Operating
CVHE	230-320	032S	032S	13191	14379	5983	6522
CVHE	230-320	032S	032L	13735	15018	6230	6812
CVHE	230-320	032L	032L	14381	15892	6523	7209
CVHE	230-320	050S	050S	16049	18000	7280	8165
CVHE	230-320	050S	050L	16864	18968	7650	8604
CVHE	230-320	050L	050L	17796	20259	8072	9189
CVHE	360-500	050S	050S	16699	18650	7575	8460
CVHE	360-500	050S	050L	17514	19618	7944	8899
CVHE	360-500	050L	050L	18446	20909	8367	9484
CVHE	360-500	080S	080S	22682	25797	10289	11702
CVHE	360-500	080S	080L	24025	27384	10898	12421
CVHE	360-500	080L	080L	25605	29497	11614	13380
CVHF	350-570	050S	050S	15694	17645	7119	8004
CVHF	350-570	050S	050L	16509	18613	7488	8443
CVHF	350-570	050L	050L	17441	19904	7911	9028
CVHF	350-570	080S	080S	21652	24767	9821	11234
CVHF	350-570	080S	080L	22995	26354	10431	11954
CVHF	350-570	080L	080L	24575	28467	11147	12913
CVHF	555-640	050S	050S	17314	19265	7854	8739
CVHF	555-640	050S	050L	18129	20233	8223	9178
CVHF	555-640	050L	050L	19061	21524	8646	9763
CVHF	555-640	080S	080S	23272	26387	10556	11969
CVHF	555-640	080S	080L	24615	27974	11165	12689
CVHF	555-640	080L	080L	26195	30087	11882	13647
CVHF	650-910	080S	080S	24242	27357	10996	12409
CVHF	650-910	080S	080L	25585	28944	11605	13129
CVHF	650-910	080L	080L	27165	31057	12322	14087
CVHF	1060-1280	142M	142L	35538	41116	16120	18650
CVHF	1060-1280	142L	142L	36352	42286	16489	19181
CVHF	1060-1280	142M	142L	36138	41716	16392	18922
CVHF	1060-1280	142L	142L	36952	42886	16761	19453
CVHF	1060-1280	142E	142L	37840	44303	17164	20096
CVHF	1060-1280	210L	210L	44666	52513	20260	23820
CVHF	1060-1280	250E	250L	54646	65616	24787	29763
CVHF	1470	210L	210L	49980	57820	22671	26227
CVHF	1470-1720	250E	250L	59960	70930	27198	32174
CVHG	480-565	050S	050S	18449	20400	8368	9253
CVHG	480-565	050S	050L	19264	21368	8738	9693
CVHG	480-565	050L	050L	20196	22659	9161	10278
CVHG	480-565	080S	080S	24432	27547	11082	12495
CVHG	480-565	080S	080L	25775	29134	11692	13215
CVHG	480-565	080L	080L	27355	31247	12408	14174
CVHG	670-780	080S	080S	25032	28147	11355	12767
CVHG	670-780	080S	080L	26375	29734	11964	13487
CVHG	670-780	080L	080L	27955	31847	12680	14446
CVHG	670-780	142M	142L	36627	42205	16614	19144
CVHG	920-1067	142L	142L	37441	43375	16983	19675
CVHG	920-1067	142M	142L	37427	43005	16977	19507
CVHG	920-1067	142L	142L	38241	44175	17346	20038
CVHG	920-1067	210L	210L	45955	53802	20845	24405

## General Information

**Note:** Immediately report any unit damage incurred during handling or installation at the job site to Trane sales office.

### Rigging

Lifting is the recommended method for moving chillers. Suggested lifting arrangements for standard and heat-recovery units are illustrated in Figure 5.

**Note that each of the cables used to lift the unit must be capable of supporting the entire weight of the chiller.**

### **WARNING**

#### **Improper Unit Lift!**

**LIFT THE CHILLER HORIZONTALLY. Failure to do so could result in death or serious injury and equipment damage.**

See Tables 2, 3 and 5 for shipping weights.

Refer to lifting arrangement and rigging in Figure 5. Notice that the lifting beam used to lift the unit must be at least 16 feet minimum effective length.

To lift the chiller properly, insert clevis connections at the points indicated in Figure 5, a 2" [51 mm] diameter lifting hole is provided at each of these points. Next attach the lifting chains or cables.

Once the lifting cables are in place, attach a safety chain or cable between the first-stage casting of the compressor and the lifting beam. To do this, remove a restraining bolt from the compressor first-stage casting and replace it with an eyebolt.

**Note:** There should not be tension on this safety cable; it is used only to prevent the unit from rolling during the lift.

If installing chiller onto spring isolators, follow instructions given on page 22 and Figures 8 and 9. Follow instructions provided by spring isolator manufacturer, being careful to not damage isolator adjustment bolt.

When the lift is complete, detach the clevis connections and safety chain. Then, remove the eyebolt that was used to secure the safety chain to the compressor, and reinstall the retaining colt in its place.

If the chiller cannot be moved using the conventional rigging method just described, consider these points.

1. If job site conditions require rigging of the chiller at an angle greater than 45° from horizontal (end-to-end) dowel-pin the compressor and remove it from the unit. Be sure to contact a qualified service organization for specific rigging instructions. Do not attempt to rotate chiller on to side.

### **CAUTION**

#### **Loss of Oil!**

**IF THE UNIT WILL BE LIFTED AT AN ANGLE GREATER THAN 15° FROM END-TO-END, REMOVE THE OIL FROM THE OIL TANK. Failure to do so, will cause oil to drain out of oil tank into other areas of chiller. It will be extremely difficult to return the oil to the oil tank even during operation.**

2. When lifting the chiller is either impractical or undesirable, attach cables or chains to the jacking slots shown in Figure 5; then push or pull the unit across a smooth surface.

**Note:** The oil tank with the refrigerant pump is mounted under the condenser and may be damaged by a fork truck.

### **CAUTION**

#### **Improper Unit Lift!**

**DO NOT USE A FORKLIFT TO REMOVE THE CHILLER. Using a forklift can result in damaged equipment.**

### **CAUTION**

#### **Compressor Misalignment!**

**CONSULT THE TRANE COMPANY BEFORE LIFTING THE COMPRESSOR/MOTOR ASSEMBLY FROM THE SHELLS WITHOUT FACTORY-INSTALLED DOWELING IN THE COMPRESSOR CASTING FLANGES. Failure to do so can result in misalignment of the compressor castings.**

3. If removal of the compressor or economizer assembly is necessary to move the chiller into its operating location, contact The Trane Company for special instructions concerning chiller disassembly and reassembly procedures.

### **CAUTION**

#### **Wiring Damage!**

**BE CAREFUL TO AVOID DAMAGING UNIT WIRING DURING RIGGING, ASSEMBLY AND DISASSEMBLY.**

# General Information

Figure 5. Recommended lifting arrangements for CVHE, CVHF, and CVHG units

**⚠ WARNING**

## Heavy Objects!

Do not use cables (chains or slings) except as shown. Each of the cables (chains or slings) used to lift the unit must be capable of supporting the entire weight of the unit. Lifting cables (chains or slings) may not be of the same length. Adjust as necessary for even unit lift. Other lifting arrangements may cause equipment or property-only damage. Failure to properly lift unit may result in death or serious injury. See details below.

**⚠ WARNING**

## Improper Unit Lift!

Test lift unit approximately 24 inches to verify proper center of gravity lift point. To avoid dropping of unit, reposition lifting point if unit is not level. Failure to properly lift unit could result in death or serious injury or possible equipment or property-only damage.

Attach safety chain or cable as shown without tension, not as a lifting chain or cable, but to prevent the unit from rolling.

Do not forklift the unit to move or lift.

Lifting holes provided on chiller to attach cables (chains or slings).

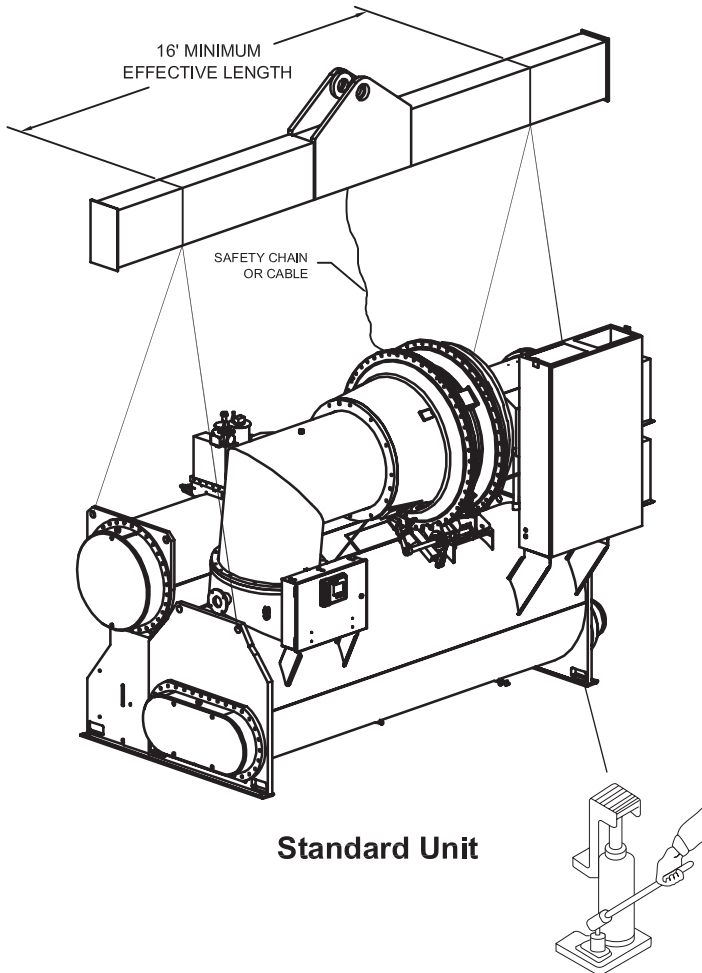

# General Information

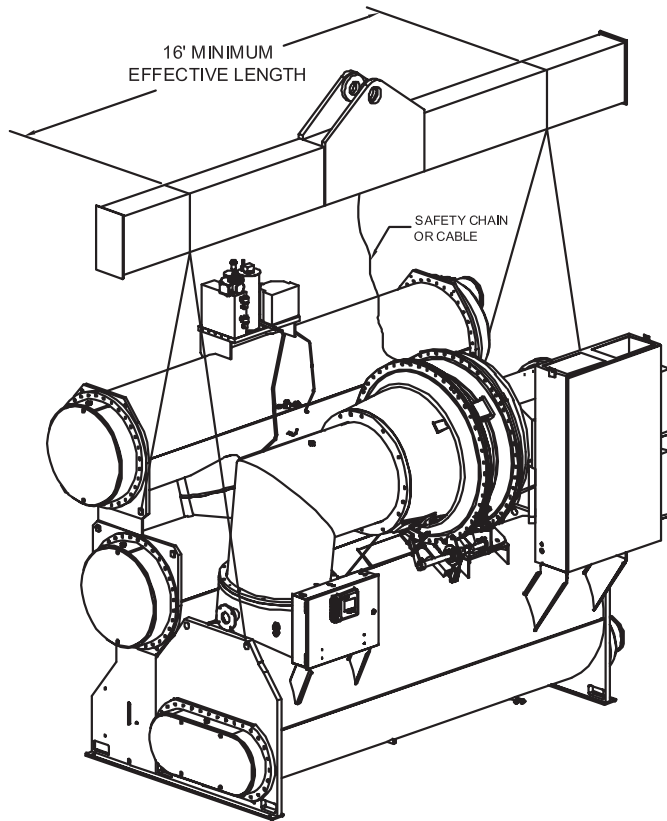

**Condenser Heat Recovery Option**

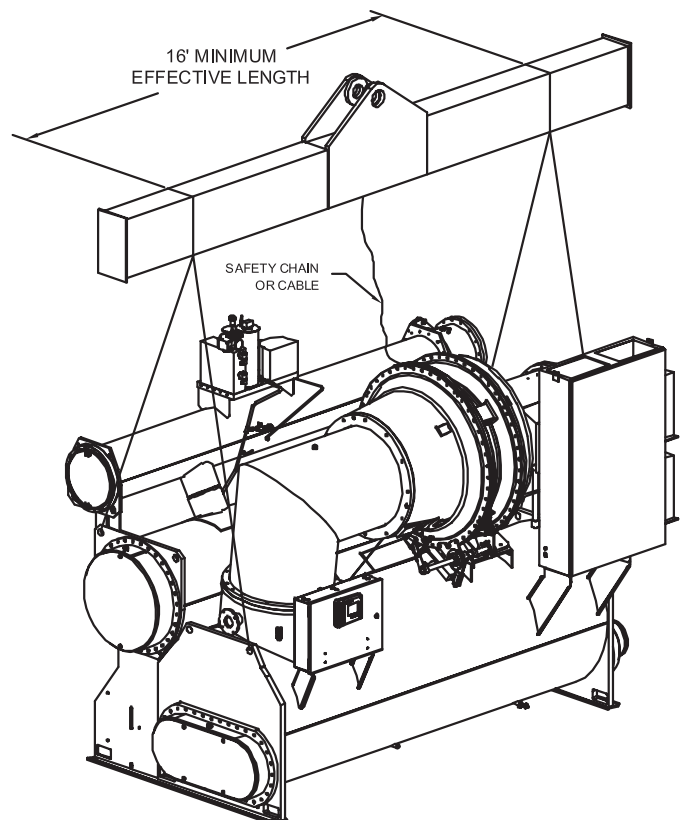

**Condenser Auxiliary Option**

# General Information

## Chiller Isolation

To minimize sound and vibration transmission through the building structure and to assure proper weight distribution over the mounting surface, install isolation pads or spring isolators under the chiller feet.

Note: Isolation pads are provided with each chiller unless spring isolators are specified on the sales order.

Specific isolator loading data is provided in the unit submittal package. Also refer to Table 6. If necessary, contact your local Trane sales office for further information.

## Isolation Pads

When the unit is ready for final placement, position isolation pads end for end under the full length of the chiller leg. The pads measure 6"×18" [152.4×457 mm] and on some units there may be small gaps between pads. Pads are provided to cover entire foot. Place 6" sides end to end under entire length of foot.

Remember that the chiller must be level within 1/16" [1.6 mm] over its length and width after it is lowered onto the isolation pads. In addition, all piping connected to the chiller must be properly isolated and supported so that it does not place any stress on the unit.

Overhead lift is recommended, if not possible, then use rectangular jacking holes in legs. See figure 5.

**Figure 6. Isolation pad**

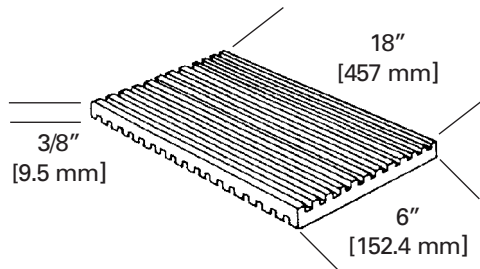

# General Information

**Table 6. Isolation pad loading**

Type	Nton	Shell Length Designators		Isolator Loading			
		EVSZ	CDSZ	Left Pad (lbs)	Left Pad (Kg)	Right Pad (lbs)	Right Pad (Kg)
CVHE	230-320	032S	032S	5758	2612	8621	3910
CVHE	230-320	032S	032L	6323	2868	8695	3944
CVHE	230-320	032L	032L	6394	2900	9519	4318
CVHE	230-320	050S	050S	7573	3435	10427	4730
CVHE	230-320	050S	050L	8428	3823	10540	4781
CVHE	230-320	050L	050L	8541	3874	11718	5315
CVHE	360-500	050S	050S	7883	3576	10767	4884
CVHE	360-500	050S	050L	8737	3963	10881	4936
CVHE	360-500	050L	050L	8818	4000	12091	5484
CVHE	360-500	080S	080S	11391	5167	14406	6535
CVHE	360-500	080S	080L	12791	5802	14594	6620
CVHE	360-500	080L	080L	12966	5881	16531	7498
CVHF	350-570	050S	050S	7298	3310	10347	4693
CVHF	350-570	050S	050L	8154	3699	10459	4744
CVHF	350-570	050L	050L	8311	3770	11593	5259
CVHF	350-570	080S	080S	10777	4888	13990	6346
CVHF	350-570	080S	080L	12178	5524	14177	6431
CVHF	350-570	080L	080L	12436	5641	16031	7272
CVHF	555-640	050S	050S	7701	3493	11564	5245
CVHF	555-640	050S	050L	8556	3881	11677	5297
CVHF	555-640	050L	050L	8726	3958	12798	5805
CVHF	555-640	080S	080S	11214	5087	15173	6882
CVHF	555-640	080S	080L	12614	5722	15360	6967
CVHF	555-640	080L	080L	12876	5841	17211	7807
CVHF	650-910	080S	080S	11835	5368	15522	7041
CVHF	650-910	080S	080L	13233	6002	15711	7127
CVHF	650-910	080L	080L	13427	6090	17630	7997
CVHF	650-910	142M	142L	19976	9061	21675	9832
CVHF	650-910	142L	142L	18791	8524	23495	10657
CVHF	1060-1280	142M	142L	20076	9106	22170	10056
CVHF	1060-1280	142L	142L	18919	8582	23967	10871
CVHF	1060-1280	142E	142L	21235	9632	23068	10464
CVHF	1060-1280	210L	210L	23030	10446	29483	13373
CVHF	1060-1280	250E	250L	30991	14058	34626	15706
CVHF	1470	210L	210L	26420	11984	31400	14243
CVHF	1470-1720	250E	250L	33520	15205	37410	16969
CVHG	480-565	050S	050S	8551	3879	11849	5375
CVHG	480-565	050S	050L	9403	4265	11965	5427
CVHG	480-565	050L	050L	9439	4282	13220	5997
CVHG	480-565	080S	080S	11910	5402	15637	7093
CVHG	480-565	080S	080L	13308	6037	15826	7179
CVHG	480-565	080L	080L	13477	6113	17771	8061
CVHG	670-780	080S	080S	12129	5502	16018	7266
CVHG	670-780	080S	080L	13527	6136	16207	7351
CVHG	670-780	080L	080L	13683	6207	18164	8239
CVHG	670-780	142M	142L	20575	9333	22160	10052
CVHG	920-1067	142L	142L	19389	8795	23986	10880
CVHG	920-1067	142M	142L	21053	9550	23082	10470
CVHG	920-1067	142L	142L	19767	8966	24409	11072
CVHG	920-1067	210L	210L	23816	10803	29986	13602

## General Information

---

Figure 7. Isolation spring placement

Shells Size Evap Length/Cond Length

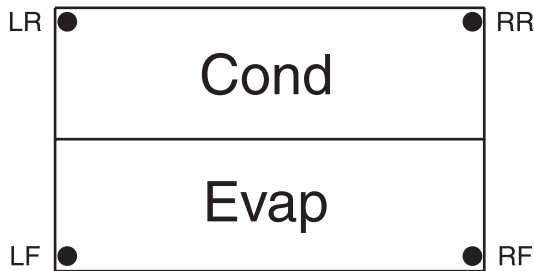

032 S/S, S/L, L/L  
 050 S/S, S.L, L/L  
 080 S/S, S/L, L/L  
 142 M/L, L/L  
 210 L/L

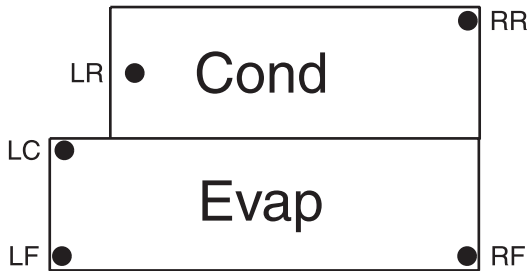

142 E/L  
 250 E/L

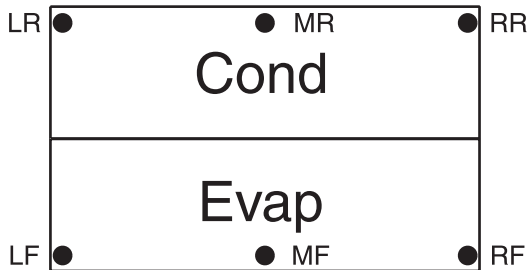

210 D/D  
 250 D/D

## General Information

---

### Spring Isolators

Spring isolators should be considered whenever chiller installation is planned for an upper story location. Base isolator selection and placement on the information presented in Figures 8 and 9. (Notice that three types of spring isolators, each with their own maximum loading characteristics, are used with the CVHE/F/G chillers.)

Spring isolators typically ship assembled and ready for installation. To install and adjust the isolators properly, follow the instructions given.

**Note:** Do not adjust the isolators until the chiller is piped and charged with refrigerant and water.

1. Position the spring isolators under the chiller as shown in Figures 7 and 8. Make sure that each isolator is centered in relation to the tube sheet.
2. Set the isolators on the sub-base; shim or grout as necessary to provide a flat, level surface at the same elevation for all mountings. Be sure to support the full underside of the isolator base plate; do not straddle gaps or small shim.
3. If required, bolt the isolators to the floor through the slots provided or cement the pads.

**Note:** Fastening the isolators to the floor is not necessary unless specified.

4. If the chiller must be fastened to the isolators, insert cap screws through the chiller base and into the holes tapped in the upper housing of each isolator. However, do not allow the screws to protrude below the underside of the isolator upper housing. An alternative method of fastening the chiller to the isolators is to cement the neoprene pads.
5. Set the chiller on the isolators; refer to "Rigging" for listing instructions.

The weight of the chiller will force the upper housing of each isolator down, perhaps causing it to rest on the isolator's lower housing. Figure 9 illustrates spring isolator construction.

6. Check the clearance on each isolator. If this dimension is less than  $\frac{1}{4}$  inch on any isolator, use a wrench to turn the adjusting bolt one complete revolution upward.

Repeat this operation until a  $\frac{1}{4}$  inch clearance is obtained at one or more isolators.

**Note:** When the load is applied to the isolators (Step 5), the top plate of each isolator moves down to compress the springs until either:

- (1) The springs support the load, or
- (2) The top plate rests on the bottom housing of the isolator.

- a. If the springs are supporting the load, screwing down on the adjusting bolt (Step 7) will immediately begin to raise the chiller.

7. Turn the adjusting bolt on each of the remaining isolators to obtain the required minimum clearance of  $\frac{1}{4}$ " [6.9 mm].
8. Once the minimum required clearance is obtained on each of the isolators, level the chiller by turning the adjusting bolt on each of the isolators on the low side of the unit. Be sure to work from one isolator to the next. Remember that the chiller must be level to within  $\frac{1}{16}$ " [1.6 mm] over its length and width, and that clearance of each isolator must be  $\frac{1}{4}$ " [6.9 mm].

# General Information

**Figure 8. Chiller foot/isolator orientation**

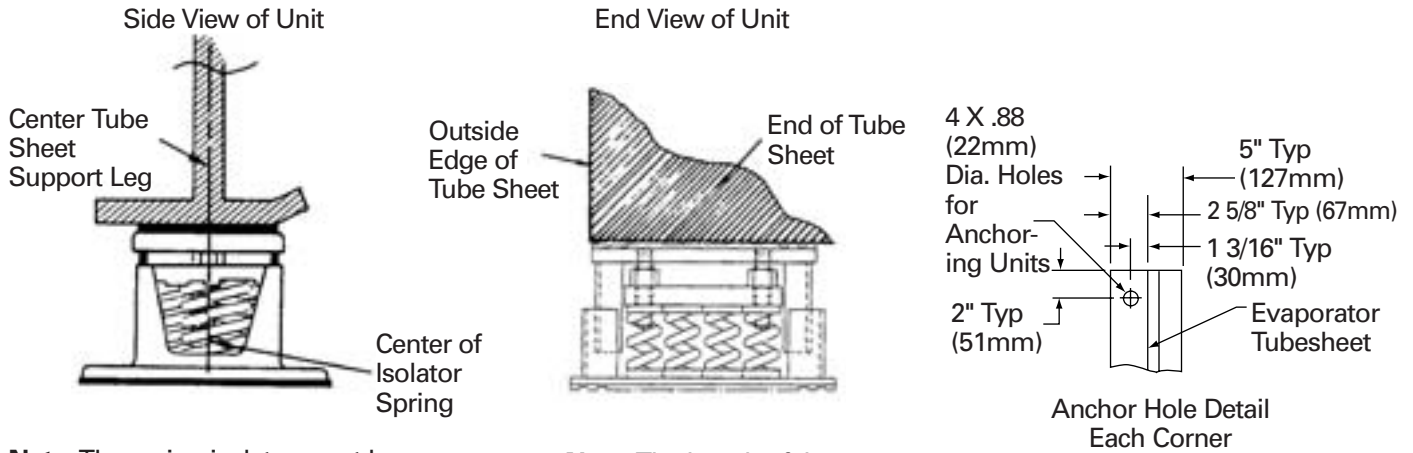

**Note:** The spring isolator must be centered in relation to the tube sheet. Do **not** align the isolator with the flat part of the chiller foot since the tube sheet is often off-center.

**Note:** The length of the isolator should be parallel to the leg.

**Figure 9. Typical spring isolator types and construction**

## Type CT-4 Spring Isolators

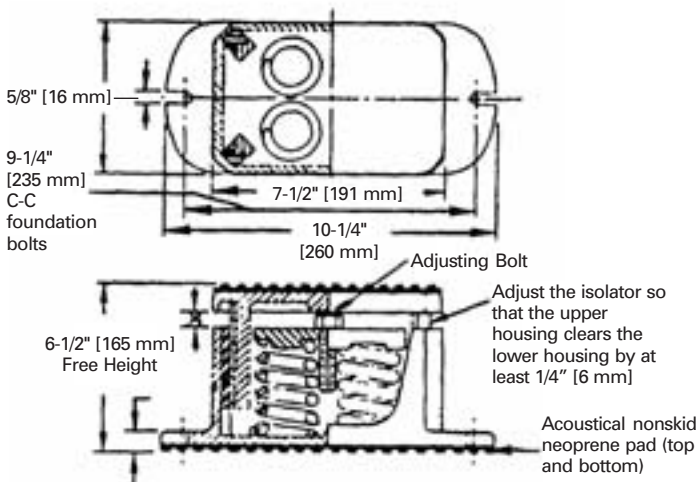

Isolator Type and Size	Maximum Load (lbs.)	Deflection (Inches)	Spring Color Coding
CT-4-25	1,800	1.22	Red
CT-4-26	2,400	1.17	Purple
CT-4-27	3,000	1.06	Orange
CT-4-28	3,600	1.02	Green
CT-4-31	4,400	0.83	Gray
CT-4-32	5,200	0.74	White

Note: Each type CT-4 spring isolator has 4 springs.

# General Information

Figure 9 (continued). Typical spring isolator types and construction

## Type CT-7 Spring Isolators

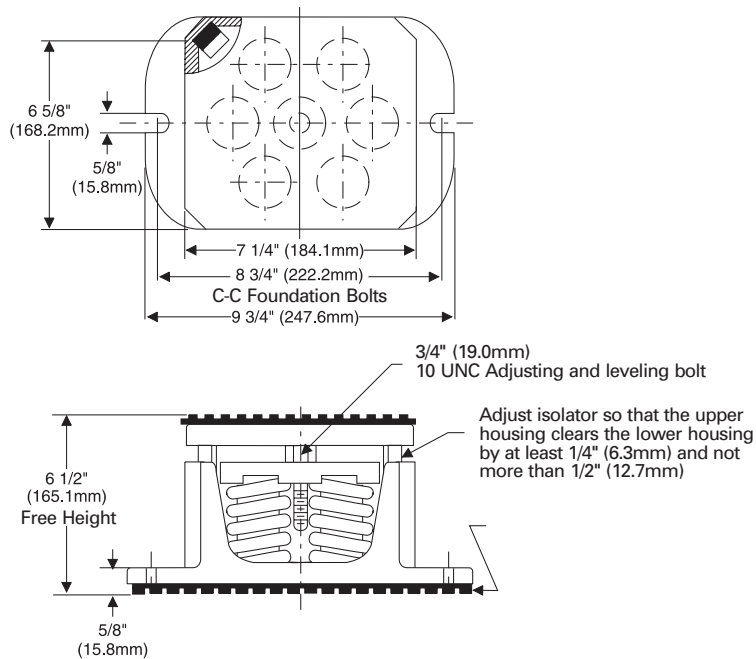

Isolator Type and Size	Maximum Load (lbs.)	Deflection (Inches)	Spring Color Coding
CT-7-25	3,150	1.22	Red
CT-7-26	4,200	1.17	Purple
CT-7-27	5,250	1.06	Orange
CT-7-28	6,300	1.02	Green
CT-7-31	7,700	0.83	Gray
CT-7-32	9,100	0.74	White

Note: Each Type CT-7 Spring Isolator has 7 Springs

## CT-12 Spring Isolators

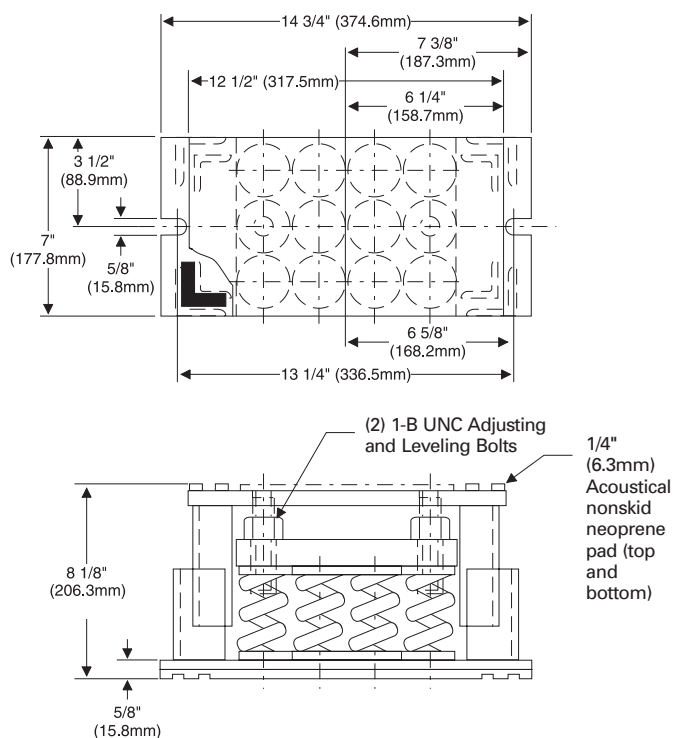

Isolator Type and Size	Maximum Load (lbs.)	Deflection (Inches)	Spring Color Coding
CT-12-25	5,400	1.22	Red
CT-12-26	7,200	1.17	Purple
CT-12-27	9,000	1.06	Orange
CT-12-28	10,800	1.02	Green
CT-12-31	13,200	.83	Gray
CT-12-32	15,600	.74	White

Note: Each type CT-12 spring isolator has 12 springs.

# General Information

Figure 9 (continued). Typical spring isolator types and construction

## CT-16 Spring Isolators

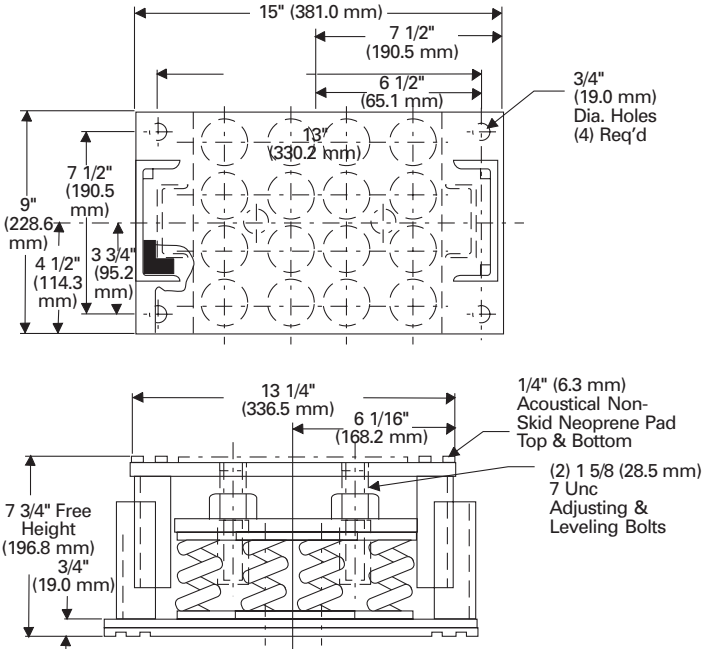

Isolator Type and Size	Maximum Load (lbs.)	Deflection (Inches)	Spring Color Coding
CT 16-26	9600	1.17	Purple
CT 16-27	12000	1.06	Orange
CT 16-28	14400	1.02	Green
CT 16-31	17600	0.83	Gray
CT 16-32	20800	0.74	White

Note: Each type CT-16 spring isolator has 16 springs.

## CT-20 Spring Isolators

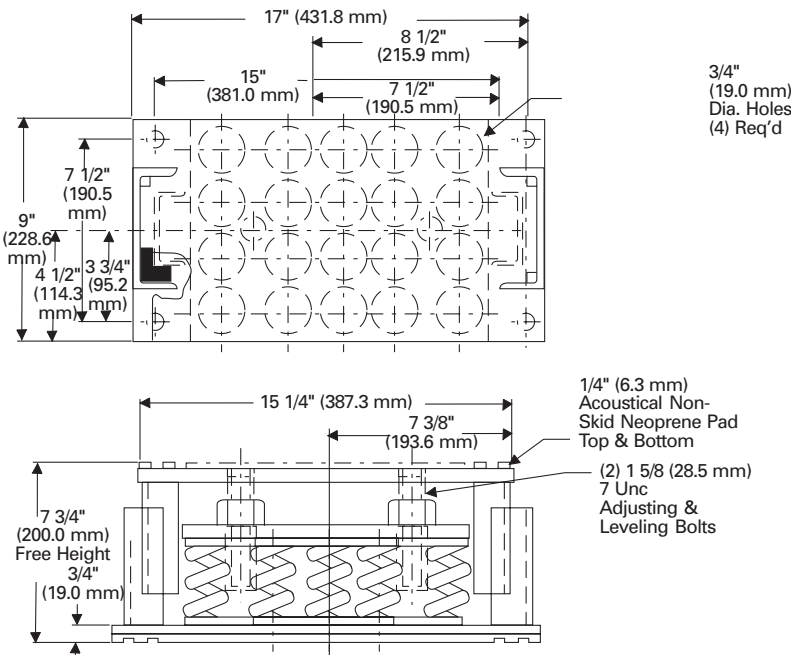

Isolator Type and Size	Maximum Load (lbs.)	Deflection (Inches)	Spring Color Coding
CT 20-26	12000	1.17	Purple
CT 20-27	15000	1.06	Orange
CT 20-28	18000	1.02	Green
CT 20-31	22000	0.83	Gray
CT 20-32	26000	0.74	White

Note: Each type CT-20 spring isolator has 20 springs.

## General Information

### Unit Leveling

Follow the instructions outlined below and illustrated in Figure 10 to determine whether or not the chiller is set level.

1. Measure an equal distance up from each foot of the chiller and make a punch mark at each measured distance.
2. Suspend a clear plastic tube along the length of the chiller as shown in Figure 10.
3. Fill the tube with water until the level aligns with the punch mark at one end of the chiller; then check the water level at the opposite mark.
4. Once the unit is level across its length, repeat Steps 1 through 3 to see if unit is level across the width.

If the water level does not align with the punch mark, use full-length shims to raise one end of the chiller until the water level at each end of the tube aligns with the punch marks at both ends of the chiller

**Figure 10. Checking unit levelness**

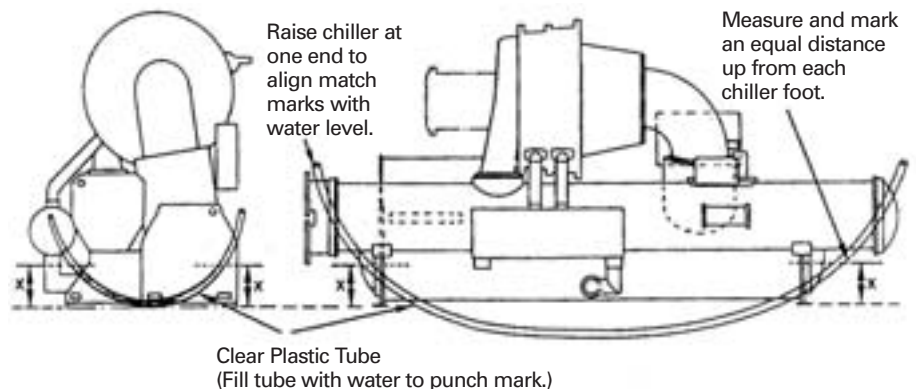



**Trane**  
**A business of American Standard Companies**  
**[www.trane.com](http://www.trane.com)**

For more information contact your local district office  
or e-mail us at [comfort@trane.com](mailto:comfort@trane.com)

Literature Order Number	CVHE-SVN01C-EN
File Number	SV-RF-CTV-CVHE-SVN01C-EN-105
Supersedes	CVHE-SVN01B-EN 104
Stocking Location	La Crosse

*Trane has a policy of continuous product and product data improvement and reserves the right to change design and specifications without notice.*

*Only qualified technicians should perform the installation and servicing of equipment referred to in this publication.*