



# Installation - CVHE-IN-9C General Information

Library	Service Literature
Product Section	Refrigeration
Product	Centrifugal Liquid Chillers, Water-Cooled
Model	CVHE, CVHF, CVHG Cooling Only & Heat Recovery
Literature Type	General Information - Installation
Sequence	9C
Date	February 1 , 2001
File No.	SV-RF-CTV-CVHE-IN-9C-2001
Supersedes	SV-RF-CTV-CVHE-IN-9B-2000

Three manuals ship together as Installation information:

**CVHE-IN-9C - General Information**  
**CVHE-IN-10C - Water Piping**  
**CVHE-IN-11C - Electrical**

## Design Sequence

CVHE "3G"  
CVHF "1T"  
CVHG "1J"

## Water Cooled CenTraVac®

CVHE 60 HZ 230, 250, 280, 320, 360, 400, 450, 500  
CVHE 50 HZ 190, 210, 240, 270, 300, 330, 370, 420  
CVHF 60 HZ 350, 410, 485, 555, 640, 650, 770, 910, 1060, 1280, 1470, 1720  
CVHG 50 HZ 350, 410, 480, 565, 670, 780, 1067

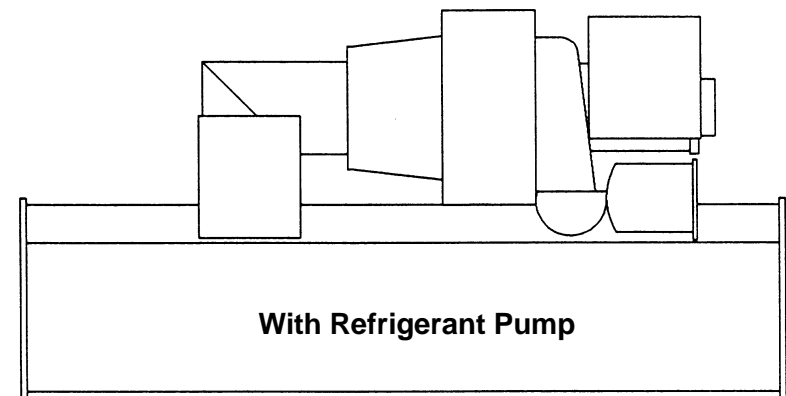

X39640503-04

# Warnings and Cautions

---

## NOTICE

**Warnings and Cautions appear at appropriate locations throughout this manual.  
Read these carefully.**

**WARNING:** Indicates a potentially hazardous situation which, if not avoided, could result in death or serious injury.

**CAUTION:** Indicates a potentially hazardous situation which, if not avoided, may result in minor or moderate injury. It may also be used to alert against unsafe practices and where property-damage-only accidents could occur.

# Table of Contents

---

<b>General Information</b>		<b>Page Number</b>
Warnings and Cautions		2
Literature Change History		4
About this Manual		4
Product Description Block		4
Commonly Used Acronyms		4
Unit Nameplate		4
Metric Conversion		4
Responsibilities of Installing Contractor(s)		5
Unit Shipment		7
Storage		7
Recommended Unit Clearances		8
Operating Environment		8
Storage Requirements - If Chiller is Not Installed		8
Foundation Requirements		10
Rigging		16
Shipping Skid Removal		18
Chiller Isolation		19
Isolation Pads		19
Spring Isolators		19
Unit Leveling		26
<b>Figures</b>		<b>Page Number</b>
Typical CVHE and CVHG Chiller with Refrigerant Pump	Figure 1	9
Clearance Requirements for Cooling and Auxiliary	Figure 2	11
Clearance Requirements for Heat Recovery	Figure 3	12
Tube Bundle Locations Showing Cooling Only, Free Cooling, Heat Recovery and Auxiliary Condenser	Figure 4	13
Recommended Lifting Arrangements for CVHE, CVHF and CVHG Units	Figure 5	17
Typical Chiller Shipping Skid	Figure 6	18
Isolation Pad	Figure 7	19
Isolation Spring Placement	Figure 8	21 - 22
Chiller Foot and Isolator Orientation	Figure 9	23
Typical Spring Isolator Types and Construction	Figure 10	24 - 25
Checking Unit Levelness	Figure 11	26
<b>Tables</b>		<b>Page Number</b>
Installation Requirements	Table 1	6
Tube Bundle Locations for Cooling Only and Free Cooling	Table 2	14
Tube Locations for Heat Recovery and Auxiliary Condenser	Table 3	14
Typical Shipping and Operating Weights (Lbs.) for Standard Options	Table 4	14
Typical Weights for Cooling Only	Table 5	15
Isolation Pad Loading	Table 6	20

# General Information

---

## Literature Change

CVHE-IN-9C - February 2001  
CVHE-IN-10C - February 2001  
CVHE-IN-11C - February 2001

CVHE-IN-9B - September 2000  
CVHE-IN-10B - September 2000  
CVHE-IN-11B - September 2000  
Supersedes:

CVHE-IN-9A - December 1999  
CVHE-IN-10A - December 1999  
CVHE-IN-11A - January 2000

## About this Manual

This manual discusses proper installation of Models CVHE, CVHF and CVHG 50 Hz. and 60 Hz. chillers with a refrigerant pump. See Figure 1 for an example of a chiller with a refrigerant pump. The chillers are equipped with microcomputer-based control systems whether standard cooling or heat-recovery. A careful review of this information along with the submittal package provided for the unit will assure that the chiller is correctly installed.

Extended capacity is available only on models CVHF 1470 and 1720.

CVHE, CVHF and CVHG machines, as of this Revision C manual, are built only with a refrigerant pump. 032 and 050 shell size information has also been included in this manual.

## Product Description Block

Trane 50 Hz and 60 Hz hermetic CenTraVac® units are defined by the product definition and selection system (PDS). Each unit is defined by the product description block which appears on the unit nameplate. An explanation of the PDS product code is provided in the unit operation and maintenance manual.

## Commonly Used Acronyms

AFD = Adjustable Frequency Drive  
ASME = American Society of Mechanical Engineers  
ASRAE = American Society of Heating, Refrigerating and Air Conditioning Engineers

BAS = Building Automation System  
LBU = La Crosse Business Unit  
CABS = Auxiliary Condenser Tube-Bundle Size  
CDBS = Condenser Bundle Size  
CESZ = Condenser Shell Size  
CWR = Chilled Water Reset

DTFL = Delta-T at Full Load (i.e., the difference between entering and leaving chilled water temperatures at design load)

EVBS = Evaporator Size  
EVSZ = Evaporator Shell Size

FC = Free Cooling  
GPM = Gallons-per-Minute  
HGBP = Hot Gas Bypass

HVAC = Heating, Ventilating and Air Conditioning

IE = Internally Enhanced Tubes

IPC = Interprocessor Communication

PFCC = Power Factor

Correction Capacitor

PSID = Pounds-per-Square-Inch Differential

UCP2 = Chiller Control Panel

## Unit Nameplate

The chiller nameplate is located on the left side of the unit control panel (UCP). The following information is provided on the unit nameplate.

1. Unit model and size descriptor
2. Unit serial number
3. Unit electrical requirements are identified
4. Correct operating charge and type of refrigerant
5. Unit test pressures and maximum operating pressures
6. Installation, operation and maintenance manuals
7. Product description block (Identifies all unit components and unit "design sequence" used to order literature and make other inquiries about the unit).
8. Lists unit wiring diagrams.

## Metric Conversion

For tables and charts in this manual, the following conversions apply:

In. x 2.54 = cm  
Ft. x 30.48 = cm  
Lbs. x .453 = kg

# General Information

---

## Responsibilities of Installing Contractor(s)

A list of the contractor responsibilities typically associated with the unit installation process is provided below. See Table 1.

1. Locate and maintain the loose parts, i.e. isolators, bulb wells, temperature sensors, flow sensors or other factory-ordered field installed options, for installation as required. Loose parts are located in the starter panel on units with factory-installed unit-mounted starters or in the motor terminal box for units with remote-mounted starters.
2. Install the machine on a foundation with flat support surfaces level within 1/16" and of sufficient strength to support concentrated loading.
3. Place manufacturer-supplied isolation pad assemblies under unit. (Use spring isolators for upper floor installations.)
4. Install the machine per applicable Trane Installation Manual.
5. Complete all water piping and electrical connections.

**Note:** Field-piping must be arranged and supported to avoid stress on the equipment. It is strongly recommended that the piping contractor refrain from piping closer than 3'-0" minimum to the equipment. This will allow for proper fit-up upon arrival of the unit at the job-site. Any adjustment that is necessary can be made to the piping at that time.

6. Where specified, supply and install valves in water piping upstream and downstream of evaporator and condenser water boxes to isolate shells for maintenance and to balance and trim system.

7. Supply and install flow switches (or equivalent devices) in both chilled water and condenser water piping. Interlock each switch with proper pump starter to ensure that unit can only operate when water flow is established.

8. Supply and install taps for thermometers and pressure gauges in water piping adjacent to inlet and outlet connections of both evaporator and condenser.

9. Supply and install drain valves to each water box.

10. Supply and install vent cocks on each water box.

11. Where specified, supply and install strainers ahead of all pumps and automatic modulating valves.

12. Supply and install pressure-relief piping from pressure-relief rupture disc to atmosphere.

13. If necessary, supply sufficient HCFC-22 refrigerant (maximum of 1 Lb. per machine) for leak testing and dry nitrogen (8 PSIG per machine) for pressure testing under manufacturer's supervision.

14. Start unit under supervision of a qualified service technician.

15. Where specified, supply and insulate evaporator and any other portions of machine as required to prevent sweating under normal operating conditions.

**16. Unit-Mounted Starters Only**  
Remove top of starter panel and cut access area for line-side wiring; front left quadrant of top provides recommended access to starter lugs.

17. Supply and install wire terminal lugs to starter.

**18. Unit-Mounted Starters Only**  
Supply and install field wiring to line-side lugs of starter.

19. Supply and install a Refrigerant Monitor per ASHRAE 15 specifications. For additional information, refer to CenTraVac® Checksheet and Request for Serviceman form 1-27.08. Contact the nearest Trane office for the most recent up to date copy.

# General Information

---

**Table 1 - Installation Requirements**

Type of Requirement	Trane-Supplied Trane-Installed	Trane-Supplied Field-Installed	Field-Supplied Field-Installed
Rigging			A. Safety chains B. Clevis connectors C. Lifting beam
Isolation		A. Isolation pads or spring isolators	A. Isolation pads or spring isolators
Electrical	A. Circuit breakers or fusible disconnects (optional) B. Unit-mounted starter (optional) C. PFCCs (optional)	A. Jumper bars B. Temperature sensor (optional outdoor air) C. Flow switches (may be field supplied)	A. Circuit breakers or fusible disconnects (optional) B. Remote-mounted starter, AFD (optional) C. PFCCs (Remote-mounted starter option only) D. Terminal lugs E. Ground connection(s) F. Jumper bars G. BAS wiring (optional) H. IPC wiring (AFD and remote-mounted starters only) I. Control voltage wiring (AFD and remote-mounted starters only) J. Oil pump interlock wiring (AFD and remote-mounted starters only) K. High condenser pressure interlock wiring (AFD and remote-mounted starters only). L. Chilled water pump contactor and wiring M. Condenser water pump contactor and wiring N. Option relays and wiring (See Table 12)
Water Piping		A. Flow switches (May be field supplied)	A. Thermometers B. Water flow pressure gauges C. Isolation and balancing valves water piping D. Vents and drain valves (1 each per class) E. Pressure-relief valves (for water boxes as required)
Rupture Disc	A. Rupture disc assy		A. Vent line and flexible connector
Insulation	a. Insulation (Optional)		A. Insulation

# General Information

---

## Unit Shipment

Each chiller ships from the factory as a hermetically-assembled package; it is factory-piped, wired and tested. All openings are covered or plugged to prevent contamination during shipment and handling.

See Figure 1 for an illustration of a typical chiller and its components. When the unit arrives at the job site, inspect it thoroughly for damage and material shortages. Suggested inspection steps below:

1. Verify that the chiller is dehydrated by checking the evaporator press gauge for an indication of holding charge pressure.
  2. To prevent damaging moisture from entering the machine and causing corrosion, each chiller is pressurized with dry nitrogen before shipment.
- Note:** The holding charge should register approximately 5 psig on the gauge at 72°F. If the charge has escaped, contact your local Trane sales office for instructions.
3. The loose parts box and isolator pads ship in the motor terminal box or unit mounted starter enclosure if so equipped. Remove the sheet metal shipping bracket from the motor terminal box and discard.
  4. Check the oil sump sight glasses to verify that the sump was factory-charged with 9 gallons of oil on units with a Refrigerant Pump and 7 gallons on units without the Refrigerant Pump.

Beginning with design sequence 2K for the CVHE, L0 for the CVHG and U0 for the CVHF a new redesigned lubrication system has been incorporated. Better visible display of the oil level indication is shown through the use of aluminum balls incorporated in the sight glass and which float when oil is present.

5. If no oil level is visible, contact your local Trane sales office.
6. Compare the chiller nameplate data (including electrical characteristics) with the corresponding ordering and shipping information to verify that the correct unit was shipped to the job site.

**7. If a thorough inspection of the chiller reveals damage or material shortages, be sure to file these claims with the carrier immediately.** Specify the extent and type of damage found, and notify the appropriate Trane sales representative. **Do not install a damaged chiller without the sales representative's approval.**

## Storage

If the chiller will be stored at the job site for an extended period of time before it is installed, exercise these precautionary measures to protect the unit from damage.

1. Do not remove the protective coverings factory-installed on the control panel and compressor inlet vane actuator for shipment.
2. Store the chiller in a dry vibration free and secure area. If factory insulated, protect chiller from prolonged exposure to sunlight.

**Note:** Refer to CVHE-SB-47 for extended storage or contact the local Trane Office.

# General Information



## CAUTION

**TO PREVENT DAMAGE TO THE FACTORY-INSTALLED INSULATION, do not allow excessive exposure to sunlight.**

3. Periodically check evaporator pressure gauge to verify that 3 to 5 psig dry nitrogen @ 72°F ambient holding charge is still in the chiller. If this charge escapes, contact a qualified service organization and the Trane sales engineer that handled the order.

**Note:** The storage range for the microcomputer -based devices in the unit control panel is -40°F (-40C) to 158°F (70C).

## Recommended Unit Clearances

Adequate clearance around and above the chiller is required to allow sufficient access for service and maintenance operations.

Figures 2, 3, 4, 5 and 6 illustrate the recommended clearances for units with and without options.

**Note:** In each instance, the minimum vertical clearance above the chiller is 3-Feet.

In addition, be sure to provide at least 3-Feet of working space in front of the unit control panel to satisfy Article 110-16 of the National Electric Code.

**Important:** Do NOT install piping or conduit above the compressor motor assembly or behind the suction elbow.

(Specific unit clearance requirements are also indicated in the submittal package provided for your unit.)

## Operating Environment

Besides assuring that the site selected for chiller installation provides the necessary clearances, consider the equipment's operating environment.

To assure that electrical components operate properly, do not locate the chiller in an area exposed to dust, dirt, corrosive fumes, or excessive heat and humidity. Note that the maximum ambient temperature range for chiller operation is 100°F 38C.

## Storage Requirements - If Chiller is Not Installed

1. Store the chiller in a dry, vibration free and secure area on a solid foundation. If the chiller has factory installed insulation, protect the chiller from direct sunlight. Do not remove any of the factory installed protective coverings.

2. Do not charge the chiller with refrigerant. If the refrigerant is at the site, follow the refrigerant manufacturer's instructions for refrigerant charge.

3. A dry nitrogen holding charge of 4 to 6 psig was installed at the factory. This positive pressure must be checked monthly to insure that moisture and non-condensibles do not get into the chiller. Check the pressure gage on the evaporator shell to verify that the dry nitrogen holding charge is still in the chiller. If this charge has escaped, contact a qualified service organization to leak test and repair as necessary and also notify the Trane sales engineer that handled the order.

4. Do not operate the purge unit on the chiller.

5. The oil can be left in the chiller if an oil analysis is initially obtained after 6 months, and once each succeeding year. If no oil breakdown is evident you do not have to change oil. If breakdown is evident, the oil will need to be replaced. If an oil analysis program is not followed then the oil should be removed, discarded, and new oil installed just prior to startup by a qualified service organization.

6. The water side of the chiller requires no special attention but there may be slight scale build-up inside the tubes. Tubes should be inspected and cleaned before the unit is placed into service.

7. If the motor sits for a long time, the bearings could take a set and cause bearing problems/replacement later. Once every six months the chiller oil pump must be started and the compressor shaft rotated 450 degrees. Contact a qualified service organization to perform this task.

8. If the chiller is stored for more than five years, and the storage is expected to be indefinite, the chiller should be examined for leaks every five years from the initial storage date. Contact a qualified service organization to perform this task.

9. When the unit is to be installed, follow instruction manuals that shipped with the chiller. The services of a qualified service organization should be obtained to conduct all activities associated with the startup of a new chiller.

**Note:** Refer to CVHE-SB-47 for extended storage or contact the local Trane Office.

# General Information

---

Figure 1  
Typical CVHE and CVHG Chiller with Refrigerant and Oil Pump

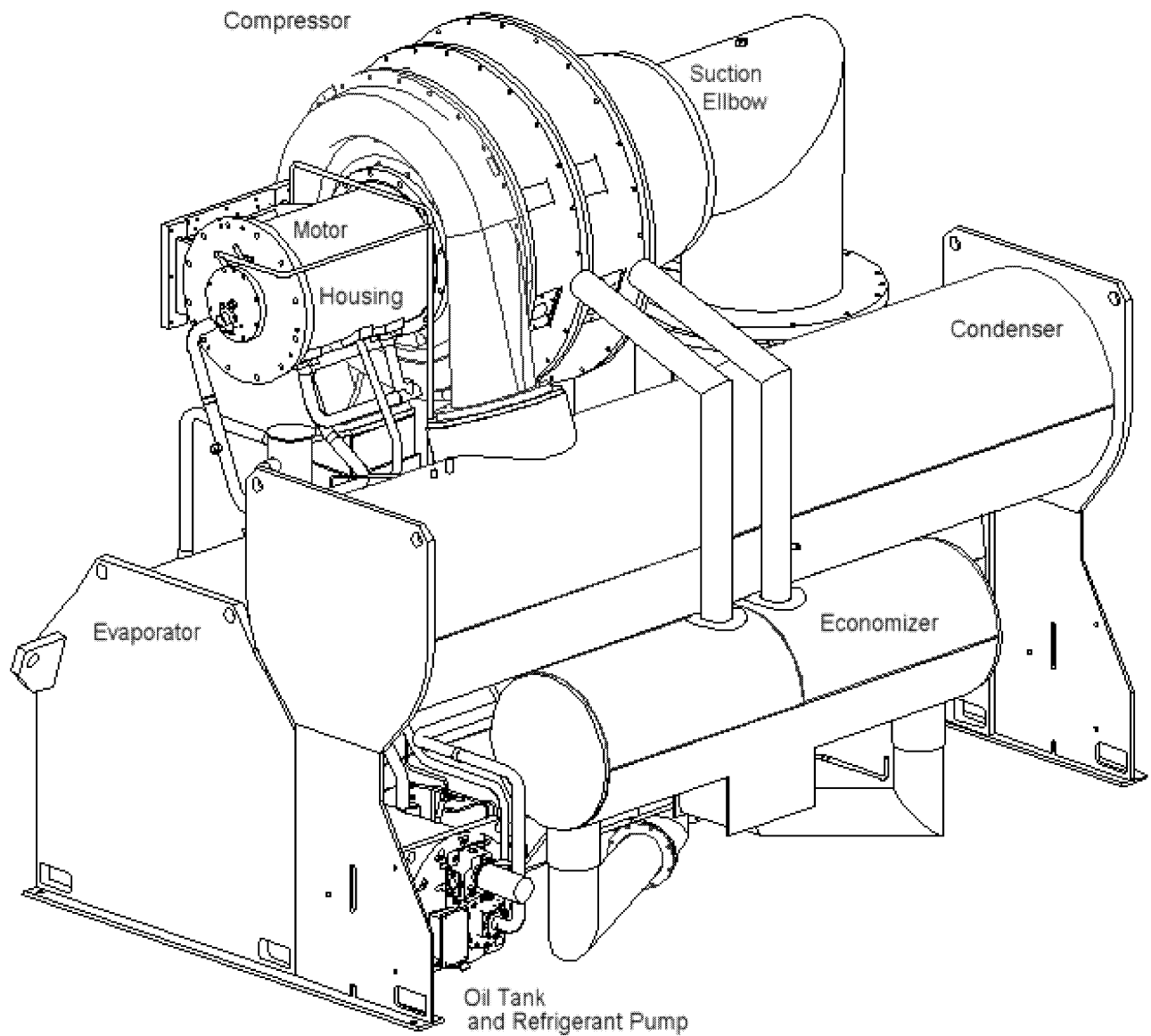

# General Information

---



## CAUTION

**CHILLER OPERATION AT AMBIENT TEMPERATURES EXCEEDING 100°F (38C) CAN FATIGUE THE UNIT'S RUPTURE DISC, CAUSING IT TO BREAK AT A REDUCED REFRIGERANT PRESSURE (I.E., <15 PSIG.) STARTER COMPONENT DAMAGE CAN ALSO OCCUR WHEN ADVERSE OPERATING CONDITIONS ARE PRESENT. THE ABOVE CAN HAPPEN, BECAUSE OF THE PANEL'S INABILITY TO DISSIPATE HEAT ADEQUATELY. Take whatever action is necessary to improve the equipment room environment if any of these adverse operating conditions are present.**

## Foundation Requirements

Provide rigid, non-warping mounting pads or a concrete foundation as a mounting surface for the chiller. Ensure that the base is of sufficient strength and mass to properly support the chiller at its full operating weight (i.e., including completed piping, and full operating charges of refrigerant, oil and water.

For your convenience, a summary of standard tube bundle locations are provided in Table 2 and Table 3. Table 4 indicates the weights of various chiller options. Table 5 shows typical weights for Cooling Only units.

Notice that the floor loading for all sizes of CVHE, CVHF and CVHG chillers is 62 pounds per square inch.

To assure proper unit operation, the chiller must be level within 1/16" over its length and width when set into place on the mounting surface.

The Trane Company will not assume responsibility for equipment problems resulting from an improperly designed or constructed foundation.

# General Information

**Figure 2**  
**Clearance Requirements for Cooling and Auxiliary Units**

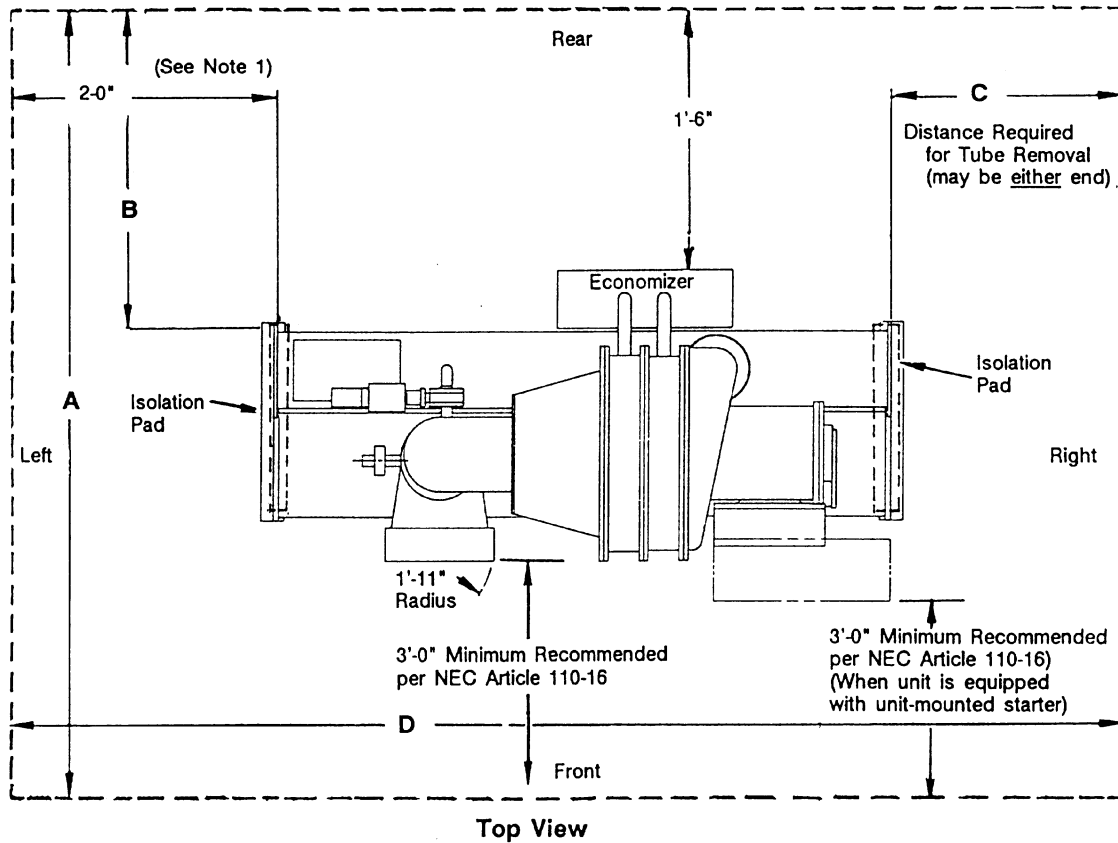

**Notes:**

- Does not include water box. Add water box dimension to this figure.
- Minimum vertical clearance over chiller is 3 feet.

Do not install piping or conduit above compressor motor assembly or behind suction elbow.

CVHE, CVHF and CVHG Cooling and Auxiliary Units (Clearances)							
DIM	SHELL COMB	EVSZ 032S/L	EVSZ 050S/L	EVSZ 080S/L	EVSZ 142M/L/E	EVSZ 210L	EVSZ 250E
A1	ALL	10'-3-1/4"	11'-1-5/8"	12'-5-1/4"	14'-5-3/4"	15'-3-3/4"	16'-5-1/2"
A2	ALL	11'-4-1/2"	12'-5-1/2"	13'-1-5/8"	15'-1"	15'-7"	16'-6-1/2"
B	ALL	2'-6-5/8"	2'-10"	2'-6-3/8"	2'-11-3/8"	3'-0-1/8"	2'-11-1/8"
C	S/S	11'-9"	11'-9"	11'-9"	N/A	N/A	N/A
	S/L, M/L, L/L	15'-6"	15'-6"	15'-6"	15'-6"	15'-6"	N/A
	E/L	N/A	N/A	N/A	17'-5"	N/A	17'-5"
D	S/S	26'-5"	26'-6-3/8"	27'-4-1/4"	N/A	N/A	N/A
	S/L, M/L, L/L	33'-11-1/4"	34'	34'-10-1/2"	35'-5-1/4"	35'-5-1/4"	N/A
	E/L	N/A	N/A	N/A	39'-3"	N/A	39'-6"

- A1 = Without Unit Mounted Starter  
A2 = With Unit Mounted Starter

**Notes:**

- EVSZ = Evaporator Size, L = Long Shell; S = Short Shell; E = Extended Shell, M = Medium Shell
- Clearance requirement to evaporator tube removal does not include water box. Add water box dimension to this figure.

# General Information

**Figure 3**  
**Clearance Requirements for Heat Recovery Units**

DIM	Shell Comb	EVSZ 032S/L	EVSZ 050S/L	EVSZ 080S/L	EVSZ 142M/L/E	EVSZ 210L	EVSZ 250E
A1	All	10'-6-5/8"	11'-2-3/4"	12'-5-3/8"	14'-10"	15'-8-1/2"	N/A
A2	All	11'-8"	12'-6-5/8"	13'-1-3/4"	15'-5-1/4"	15'-11-3/4"	
B	All	2'-10"	2'-11-1/8"	2'-6-1/2"	3'-3-5/8"	3'-10-1/4"	
C	S/S	11'-9"	11'-9"	11'-9"	N/A	N/A	
	S/L, M/L, L/L	15'-6"	15'-6"	15'-6"	15'-6"	15'-6"	
	E/L	N/A	N/A	N/A	17'-5"	N/A	
D	S/S	26'-5"	26'-6-3/8"	27'-4-1/4"	N/A	N/A	
	S/L, M/L, L/L	33'-11-1/4"	34'	34'-10-1/2"	35'-5-1/4"	35'-5-1/4"	
	E/L	N/A	N/A	N/A	39'-3"	N/A	

A1 = Without Unit Mounted Starter  
A2 = With Unit Mounted Starter

**Notes:**

1. EVSZ = Evaporator Size, L = Long Shell; S = Short Shell; E = Extended Shell
2. Clearance requirement to evaporator tube removal does not include water box. Add water box dimension in this figure.
3. Does not include water box. Add water box dimension to this figure.

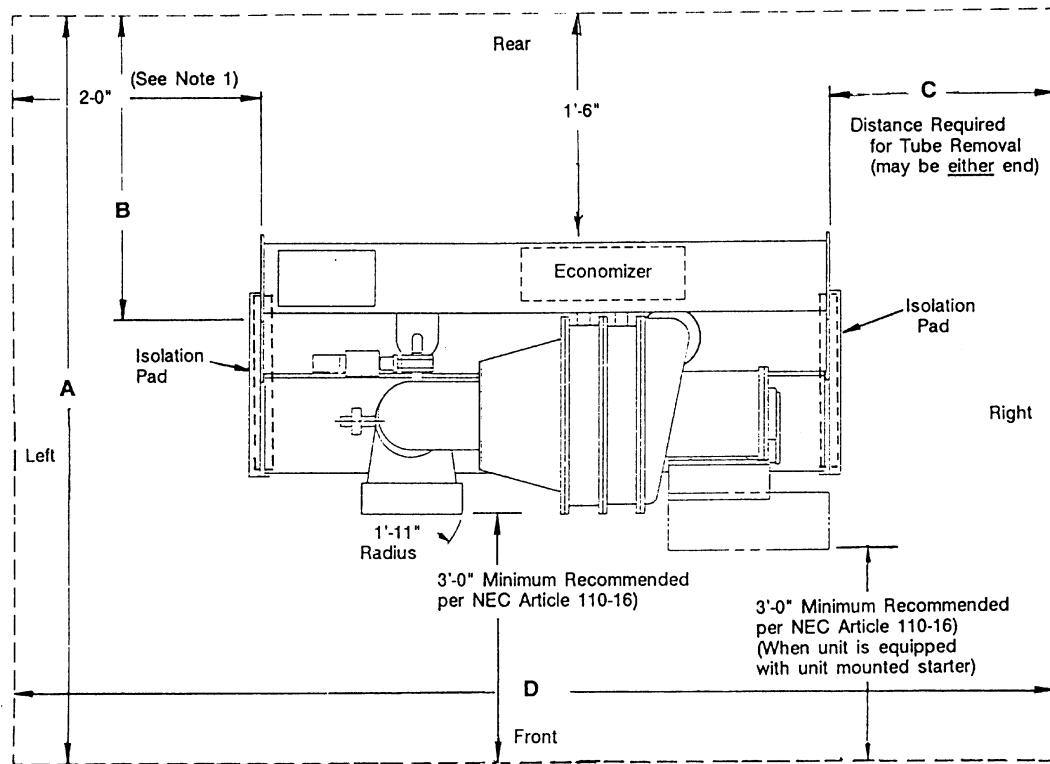

**Notes:**

1. Does not include water box.
2. Minimum vertical clearance over chiller is 3 feet.

**Top View**

**Do not install piping or conduit above compressor motor assembly or behind suction elbow!**

# General Information

**Figure 4**  
**Tube Bundle Locations Showing Cooling Only, Free Cooling, Heat Recovery and Auxiliary Condenser Units**

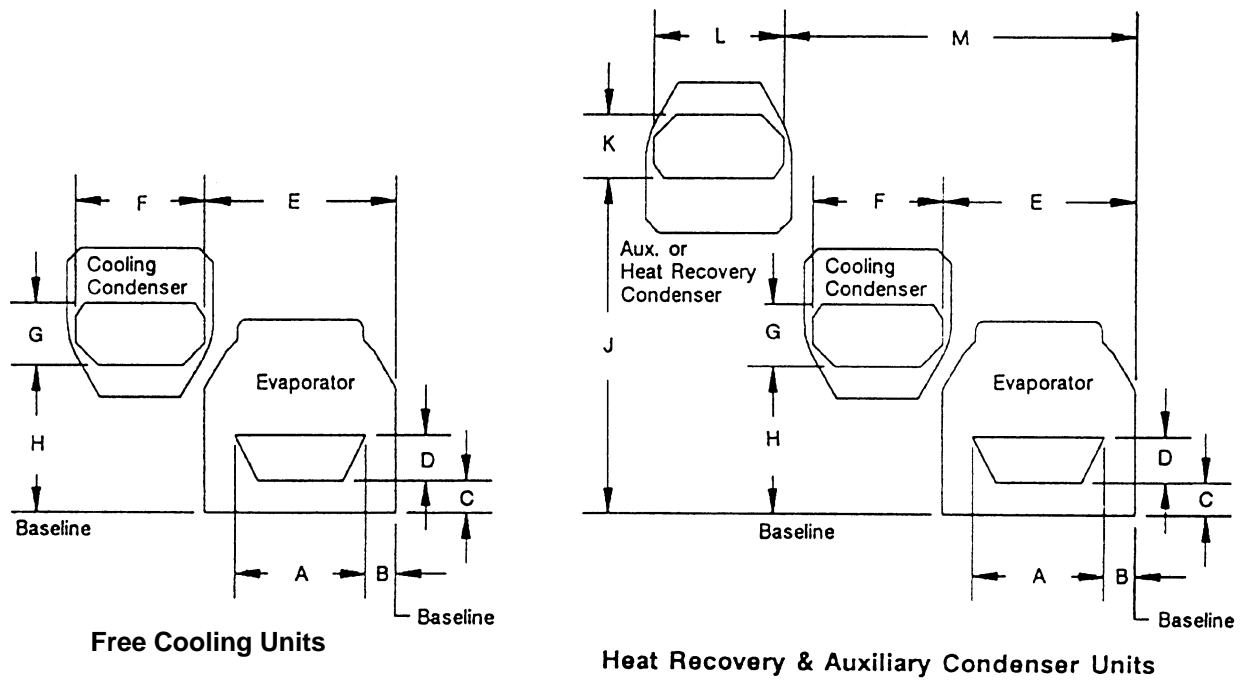

# General Information

Shell Size	Cooling Only and Free Cooling Units							
	A	B	C	D	E	F	G	H
032	2'-0-3/4"	2-5/8"	11-1/8"	7-1/4"	2'-7-3/4"	18"	10"	2'-2-3/8"
050	2'-6-3/4"	2-7/8"	9-3/8"	9-5/8"	3'-1-1/8"	1'-11-1/8"	1'-2-3/8"	2'-3-3/4"
080	3'-5-1/8"	4-1/4"	6-1/4"	11-3/8"	3'-7-3/4"	2'-4-1/8"	1'-7-1/4"	3'-7"
142	3'-10-3/8"	4-1/4"	6-5/8"	1'-2-5/8"	4'-2-3/8"	3'-3-1/8"	2'-0-7/8"	3'-8-3/8"
210	4'-5"	4-1/2"	7-1/8"	1'-5"	4'-11"	3'-7-1/2"	2'-4-1/8"	3'-9-3/4"
250	5'-0-3/4"	5-1/2"	7-1/8"	1'-7-1/4"	5'-8-5/8"	3'-10-3/4"	2'-4-1/8"	4'-0-1/4"

Shell Size	Heat Recovery				Auxiliary Condenser				
	J	K	L	M	J	K	L	M	
032	4'-6-3/8"	10-1/4"	1'-6-1/2"	4'	4'-6-3/4"	9-1/8"	1'-2"	3'-11-3/4"	
CVHE	050	5'-2-3/8"	1'-2-3/8"	1'-10-3/8"	4'-6"	5'-0-7/8"	9-1/8"	1'-2"	4'-8-1/4"
CVHF/G	050	6'-2-1/2"	1'-2-3/8"	1'-10-3/8"	4'-10"	6'-0-7/8"	9-1/8"	1'-2"	5'-0-5/8"
	080	7'-3-1/8"	1'-7-1/4"	2'-4-7/8"	4'-8-3/8"	6'-10-1/2"	9-1/8"	1'-2"	5'-8-7/8"
	142	8'-7-3/8"	2'-0-7/8"	3'-2-1/2"	6'-2"	7'-9-3/8"	9-1/8"	1'-2"	7'-3-5/8"
	210	8'-7-1/2"	2'-4-1/8"	3'-7-1/2"	6'-6-5/8"	8'-7-5/8"	9-1/8"	1'-2"	3'-9-3/4"
	250	<b>Not Available</b>							

Cond Size CDSZ	Aux Cond Size 80		Aux Cond Size 130		Heat Rec Cond		Free Cooling	
	Ship	Oper	Ship	Oper	Ship	Oper	Ship	Oper
032S	825	1057	960	1248	2119	2624	500	785
032L	825	1057	960	1248	2663	3263	500	785
050S	825	1057	960	1248	3170	4018	750	1290
050L	825	1057	960	1248	3985	4986	750	1290
080S	825	1057	960	1248	5340	6593	750	1360
080L	825	1057	960	1248	6683	8180	750	1360
142L	825	1057	960	1248	12180	14666	1400	2400
210L	825	1057	960	1248	16023	19299	1400	2400

**Notes:**

1. Unit-Mounted Starter Option = 530 Lbs. (Shipping and Operating)
2. Weights shown are accurate within ± 3% and are calculated with non-marine 150 psig water boxes. Marine-style water boxes may add considerably more weight; contact LBU Marketing for details.
3. Operating weights include refrigerant, oil and water charges.
4. For more specific data on weights and isolator loading, refer to the unit submittal package.

# General Information

**Table 5**  
**Typical Weights for Cooling Only**

Type	Nton	Shell Length Designators		Maximum Weights (Lbs.)	
		EVSZ	CDSZ	Shipping	Operating
CVHE	230-320	032S	032S	13191	14379
CVHE	230-320	032S	032L	13735	15018
CVHE	230-320	032L	032L	14381	15892
CVHE	230-320	050S	050S	16049	18000
CVHE	230-320	050S	050L	16864	18968
CVHE	230-320	050L	050L	17796	20259
CVHE	360-500	050S	050S	16699	18650
CVHE	360-500	050S	050L	17514	19618
CVHE	360-500	050L	050L	18446	20909
CVHE	360-500	080S	080S	22682	25797
CVHE	360-500	080S	080L	24025	27384
CVHE	360-500	080L	080L	25605	29497
CVHE	560-800	080S	080S	24432	27547
CVHE	560-800	080S	080L	25775	29134
CVHE	560-800	080L	080L	27355	31247
CVHF	305-485	050S	050S	15694	17645
CVHF	305-485	050S	050L	16509	18613
CVHF	305-485	050L	050L	17441	19904
CVHF	305-485	080S	080S	21652	24767
CVHF	305-485	080S	080L	22995	26354
CVHF	305-485	080L	080L	24575	28467
CVHF	555-640	050S	050S	17314	19265
CVHF	555-640	050S	050L	18129	20233
CVHF	555-640	050L	050L	19061	21524
CVHF	555-640	080S	080S	23272	26387
CVHF	555-640	080S	080L	24615	27974
CVHF	555-640	080L	080L	26195	30087
CVHF	650-910	080S	080S	24242	27357
CVHF	650-910	080S	080L	25585	28944
CVHF	650-910	080L	080L	27165	31057
CVHF	1060-1280	142M	142L	35538	41116
CVHF	1060-1280	142L	142L	36352	42286
CVHF	1060-1280	142M	142L	36138	41716
CVHF	1060-1280	142L	142L	36952	42886
CVHF	1060-1280	142E	142L	37840	44303
CVHF	1060-1280	210L	210L	44666	52513
CVHF	1060-1280	250E	250L	54646	65616
CVHF	1470	210L	210L	49980	57820
CVHF	1470-1720	250E	250L	59960	70930
CVHG	480-565	050S	050S	18449	20400
CVHG	480-565	050S	050L	19264	21368
CVHG	480-565	050L	050L	20196	22659
CVHG	480-565	080S	080S	24432	27547
CVHG	480-565	080S	080L	25775	29134
CVHG	480-565	080L	080L	27355	31247
CVHG	670-780	080S	080S	25032	28147
CVHG	670-780	080S	080L	26375	29734
CVHG	670-780	080L	080L	27955	31847
CVHG	670-780	142M	142L	36627	42205
CVHG	920-1067	142L	142L	37441	43375
CVHG	920-1067	142M	142L	37427	43005
CVHG	920-1067	142L	142L	38241	44175
CVHG	920-1067	210L	210L	45955	53802

# General Information

---

**Note:** Immediately report any unit damage incurred during handling or installation at the job site to Trane sales office.

## Rigging

Lifting is the recommended method for moving chillers. Suggested lifting arrangements for standard and heat-recovery units are illustrated in Figure 5.

**Note that each of the cables used to lift the unit must be capable of supporting the entire weight of the chiller.**

**⚠ WARNING**  
**LIFT THE CHILLER HORIZONTALLY.** Failure to do so could result in death or serious bodily injury and equipment damage.

See shipping tables 2, 3 and 5 for shipping weights.

Refer to lifting arrangement and rigging in Figure 5. Notice that the lifting beam used to lift the unit must be at least 12 feet long.

To lift the chiller properly, insert clevis connections at the points indicated in Figure 5, a 2"- diameter lifting hole is provided at each of these points. Next attach the lifting chains or cables.

Once the lifting cables are in place, attach a safety chain or cable between the first-stage casting of the compressor and the lifting beam. To do this, remove a retaining bolt from the compressor first-stage casting and replace it with an eyebolt.

**Note:** There should not be tension on this safety cable; it is used only to prevent the unit from rolling during the lift.

When the lift is complete, detach the clevis connections and safety chain, then remove the eyebolt that was used to secure the safety chain to the compressor, and reinstall the retaining bolt in its place.

If the chiller cannot be moved using the conventional rigging method just described, consider these points.

1. If job site conditions require rigging of the chiller at an angle greater than 45° from horizontal (end-to-end), dowel-pin the compressor and remove it from the unit. Be sure to contact a qualified service organization for specific rigging instructions.

**⚠ CAUTION**  
**IF THE UNIT WILL BE LIFTED AT ANY ANGLE GREATER THAN 15° FROM END-TO-END, REMOVE THE OIL FROM THE OIL TANK.** Failure to do so, will cause oil to drain out of oil tank into other areas of chiller. It will be extremely difficult to return the oil to the oil tank even during operation.

2. When lifting the chiller is either impractical or undesirable, attach cables or chains to the jacking slots shown in Figure 5; then push or pull the unit across a smooth surface.

**⚠ CAUTION**  
**CHILLER SHIPPING SKIDS ARE NOT DESIGNED TO SUPPORT THE ENTIRE WEIGHT OF THE UNIT AT ANY POINT.** Improperly supporting the chiller and skid assembly may result in equipment damage.

**Note:** The oil tank with the refrigerant pump is mounted under the condenser and may be damaged by a fork truck.

**⚠ CAUTION**  
**DO NOT USE A FORK LIFT TO REMOVE THE CHILLER.** Using a fork lift can result in damaged equipment.

**⚠ CAUTION**  
**CONSULT THE TRANE COMPANY BEFORE LIFTING THE COMPRESSOR/MOTOR ASSEMBLY FROM THE SHELLS WITHOUT FACTORY-INSTALLED DOWELING IN THE COMPRESSOR CASTING FLANGES.** Failure to do so can result in misalignment of the compressor castings.

3. If removal of the compressor or economizer assembly is necessary to move the chiller into its operating location, contact the Trane Company for special instructions concerning chiller disassembly and reassembly procedures. Refer to CVHE-IN-3B or latest revision.

# General Information

Figure 5  
Recommended Lifting Arrangements for CVHE, CVHF and CVHG Units

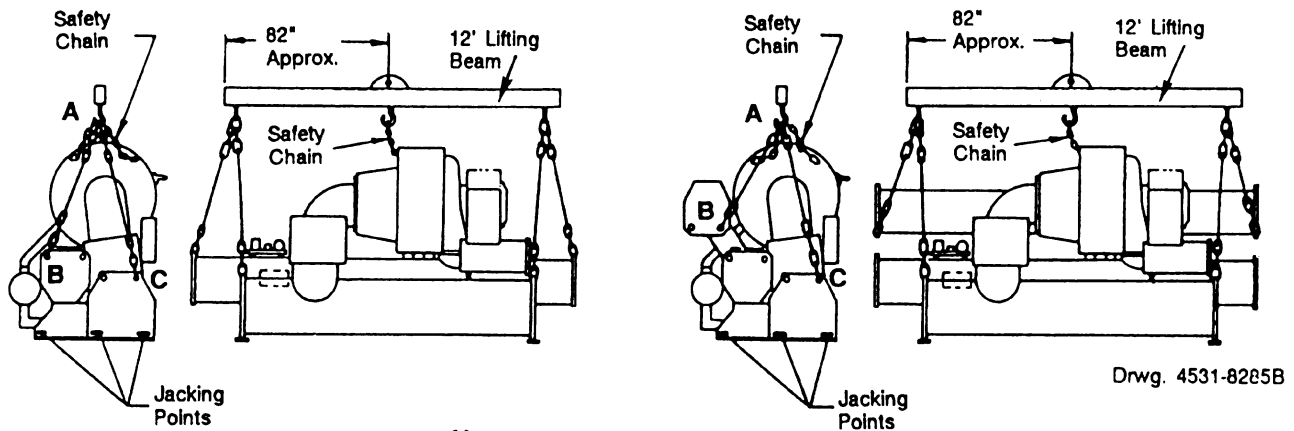

**Notes:**

1. Lifting chains (or cables) may or may not be the same length between Points A and B, or between Points A and C. Adjust as necessary for an even lift.
2. Lifting holes provided on chiller to attach chains are 2" in diameter.
3. Attach safety chain (or cable) as shown, and without tension. The safety chain is not used for lifting, but is there to prevent the unit from rolling.
4. Do not forklift the unit!



**WARNING**  
**DO NOT USE CHAINS OR CABLES OTHER THAN AS SHOWN.** Failure to heed this warning by using alternative lifting arrangements may result in death or serious injury and equipment damage.

# General Information

---

## Shipping Skid Removal

To detach the skid from the unit once the chiller is set into place:

1. Remove the carriage bolts that fasten the steel straps to the skids. Carriage bolt locations are shown in Figure 6.
2. Place jacks in the slots provided at each end of the chiller.
3. Using the jacks installed in Step 2, elevate one end of the chiller at a time; work from end to end in small increments to ensure stability. The skid will remain on the floor.
4. Once the chiller is elevated sufficiently, disassemble and remove the skid.



### WARNING

**SHIPPING SKIDS ARE HEAVY AND SHOULD NOT BE DROPPED. Failure to handle with care may cause death or bodily injury.**

5. Position isolator pads (Spring isolators) beneath the chiller feet. (See "Unit Isolation" section for instructions.

6. Once the isolators are in place, lower the chiller. Again, work from end to end in small increments to maintain stability.

**Figure 6**  
**Typical Chiller Shipping Skid**

**Caution: Chiller shipping skid is NOT designed to support entire weight of unit at any single point. Improperly supporting chiller-and-skid assembly may result in unit damage.**

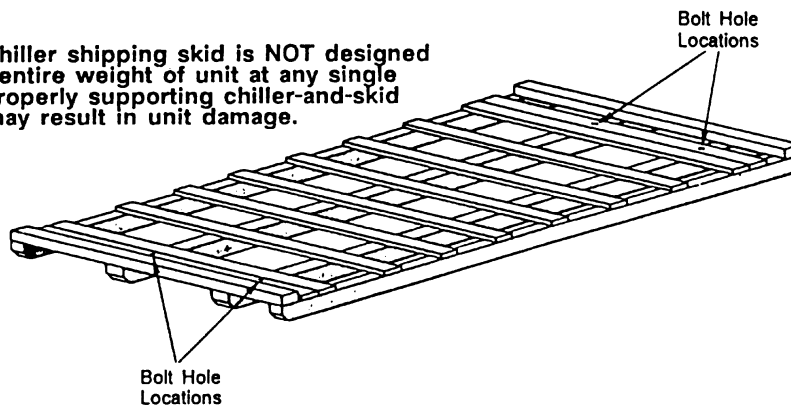

# General Information

---

## Chiller Isolation

To minimize sound and vibration transmission through the building structure and to assure proper weight distribution over the mounting surface, install isolation pads or spring isolators under the chiller feet.

**Note:** Isolation pads are provided with each chiller unless spring isolators are specified on the sales order.

Specific isolator loading data is provided in the unit submittal package. Also refer to Table 6. If necessary, contact your local Trane sales office for further information.

## Isolation Pads

When the unit is ready for final placement, position isolation pads end for end under the full length of the chiller leg. The pads measure 6" x 18" and on some units there may be small gaps between pads.

Remember that the chiller must be level within 1/16" over its length and width after it is lowered onto the isolation pads. In addition, all piping connected to the chiller must be properly isolated and supported so that it does not place any stress on the unit.

## Spring Isolators

Spring isolators should be considered whenever chiller installation is planned for an upper story location. Base isolator selection and placement on the information presented in Figures 9 and 10. (Notice that 3 types of spring isolators - each with its own maximum loading characteristics are used with the CVHE, CVHF and CVHG chillers.)

Spring isolators typically ship assembled and ready for installation. To install and adjust the isolators properly, follow the instructions given.

**Note:** Do not adjust the isolators until the chiller is piped and charged with refrigerant and water.

1. Position the spring isolators under the chiller as shown in Figures 8, and 9. Make sure that each isolator is centered in relation to the tube sheet.

2. Set the isolators on the sub-base; shim or grout as necessary to provide a flat, level surface at the same elevation for all mountings. Be sure to support the full underside of the isolator base plate; do not straddle gaps or small shims.

**Figure 7**  
**Isolation Pad**

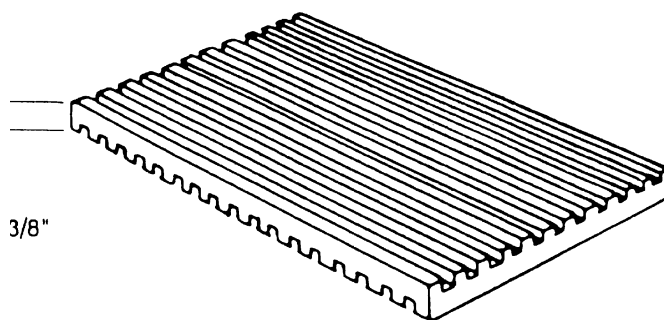

# General Information

---

<b>Table 6</b>					
<b>Isolation Pad Loading</b>					
		<b>Shell Length Designators</b>		<b>Isolator Loading</b>	
<b>TYPE</b>	<b>NTON</b>	<b>EVSZ</b>	<b>CDSZ</b>	<b>LEFT PAD</b>	<b>RIGHT PAD</b>
CVHE	230-320	032S	032S	5758	8621
CVHE	230-320	032S	032L	6323	8695
CVHE	230-320	032L	032L	6394	9519
CVHE	230-320	050S	050S	7573	10427
CVHE	230-320	050S	050L	8428	10540
CVHE	230-320	050L	050L	8541	11718
CVHE	360-500	050S	050S	7883	10767
CVHE	360-500	050S	050L	8737	10881
CVHE	360-500	050L	050L	8818	12091
CVHE	360-500	080S	080S	11391	14406
CVHE	360-500	080S	080L	12791	14594
CVHE	360-500	080L	080L	12966	16531
CVHE	560-800	080S	080S	11910	15637
CVHE	560-800	080S	080L	13308	15826
CVHE	560-800	080L	080L	13477	17855
CVHF	305-485	050S	050S	7298	10347
CVHF	305-485	050S	050L	8154	10459
CVHF	305-485	050L	050L	8311	11593
CVHF	305-485	080S	080S	10777	13990
CVHF	305-485	080S	080L	12178	14177
CVHF	305-485	080L	080L	12436	16031
CVHF	555-640	050S	050S	7701	11564
CVHF	555-640	050S	050L	8556	11677
CVHF	555-640	050L	050L	8726	12798
CVHF	555-640	080S	080S	11214	15173
CVHF	555-640	080S	080L	12614	15360
CVHF	555-640	080L	080L	12876	17211
CVHF	650-910	080S	080S	11835	15522
CVHF	650-910	080S	080L	13233	15711
CVHF	650-910	080L	080L	13427	17630
CVHF	650-910	142M	142L	19976	21675
CVHF	650-910	142L	142L	18791	23495
CVHF	1060-1280	142M	142L	20076	22170
CVHF	1060-1280	142L	142L	18919	23967
CVHF	1060-1280	142E	142L	21235	23068
CVHF	1060-1280	210L	210L	23030	29483
CVHF	1060-1280	250E	250L	30991	34626
CVHF	1470	210L	210L	26420	31400
CVHF	1470-1720	250E	250L	33520	37410
CVHG	480565	050S	050S	8551	11849
CVHG	480565	050S	050L	9403	11965
CVHG	480565	050L	050L	9439	13220
CVHG	480565	080S	080S	11910	15637
CVHG	480565	080S	080L	13308	15826
CVHG	480565	080L	080L	13477	17771
CVHG	670780	080S	080S	12129	16018
CVHG	670780	080S	080L	13527	16207
CVHG	670780	080L	080L	13683	18164
CVHG	670780	142M	142L	20575	22160
CVHG	920, 1067	142L	142L	19389	23986
CVHG	920, 1067	142M	142L	21053	23082
CVHG	920, 1067	142L	142L	19767	24409
CVHG	920, 1067	210L	210L	23816	29986

# General Information

---

**Figure 8**  
**Isolation Spring Placement (Continued on the next page)**

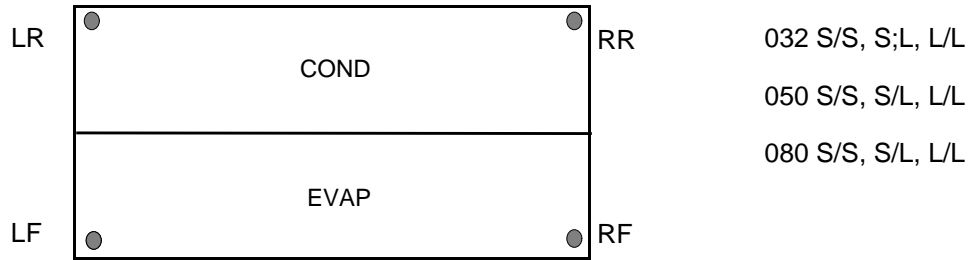

032 S/S, S;L, L/L  
 050 S/S, S/L, L/L  
 080 S/S, S/L, L/L

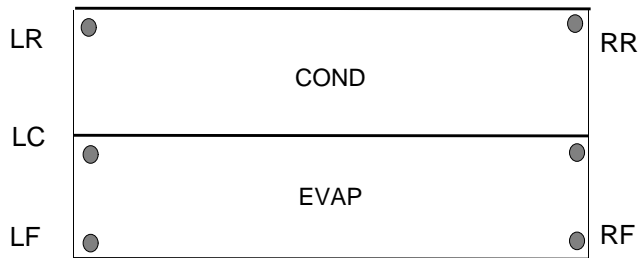

142 M/L, L/L  
 210 L/L

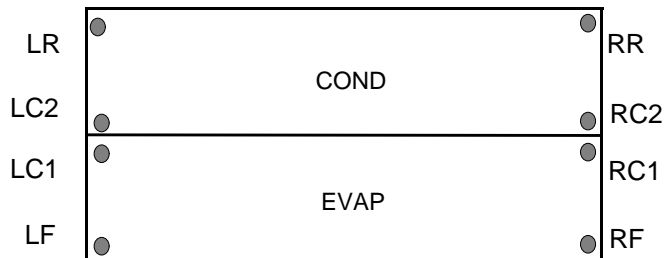

142 L/L (Heat Recovery)

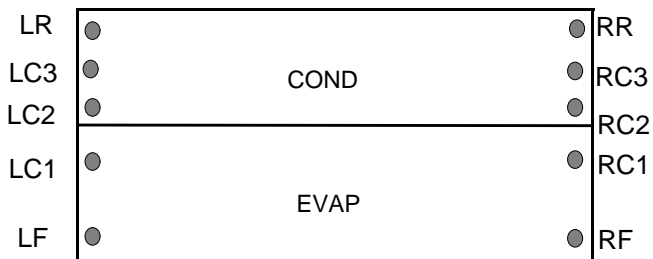

210 L/L (Heat Recovery)

Continued next page

# General Information

---

**Figure 8**  
**Isolation Spring Placement (Continued)**

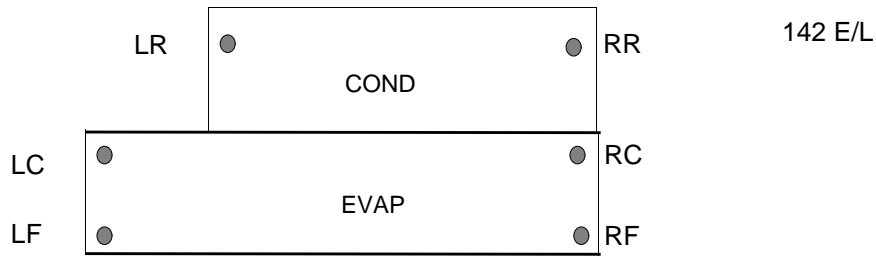
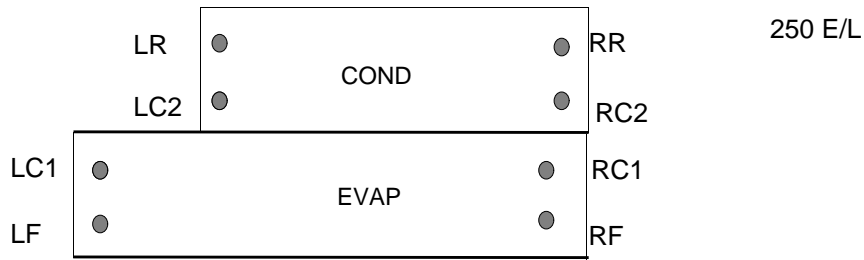

# General Information

3. If required, bolt the isolators to the floor through the slots provided, or cement the pads.

**Note:** Fastening the isolators to the floor is not necessary unless specified.

4. If the chiller must be fastened to the isolators, insert cap screws through the chiller base and into the holes tapped in the upper housing of each isolator. However, do not allow the screws to protrude below the underside of the isolator upper housing. An alternative method of fastening the chiller to the isolators is to cement the neoprene pads.

5. Set the chiller on the isolators; refer to "Rigging" for listing instructions.

The weight of the chiller will force the upper housing of each isolator down, perhaps causing it to rest on the isolator's lower housing. Figure 10 illustrates spring isolator construction.

6. Check the clearance on each isolator. If this dimension is less than 1/4-inch on any isolator, use a wrench to turn the adjusting bolt one complete revolution upward.

Repeat this operation until a 1/4-inch clearance is obtained at one or more isolators.

**Note:** When the load is applied to the isolators (Step 5), the top plate of each isolator moves down to compress the springs until either;  
 (1) The springs support the load; or  
 (2) The top plate rests on the bottom housing of the isolator.

a. If the springs are supporting the load, screwing down on the adjusting bolt (Step 7) will immediately begin to raise the chiller.

7. Turn the adjusting bolt on each of the remaining isolators to obtain the required minimum clearance of 1/4-inch.

8. Once the minimum required clearance is obtained on each of the isolators, level the chiller by turning the adjusting bolt on each of the isolators on the low side of the unit. Be sure to work from one isolator to the next. Remember that the chiller must be level to within 1/16: over its length and width, and that clearance of each isolator must be 1/4-inch.

**Figure 9**  
**Chiller Foot and Isolator Orientation**

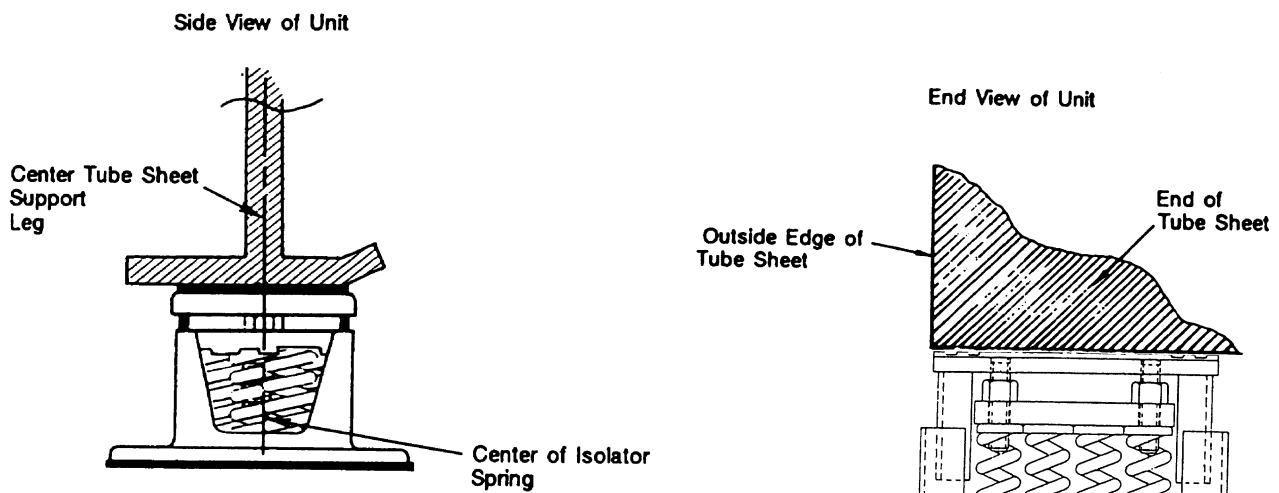

**Note:** The spring isolator must be centered in relation to the tube sheet. Do **not** align the isolator with the flat part of the chiller foot since the tube sheet is often off-center.

Note: The length of the Isolator should be parallel to the leg.

# General Information

**Figure 10**  
**Typical Spring Isolator Types and Construction (Continued next page)**

**Type CT-4**  
**Spring Isolators**

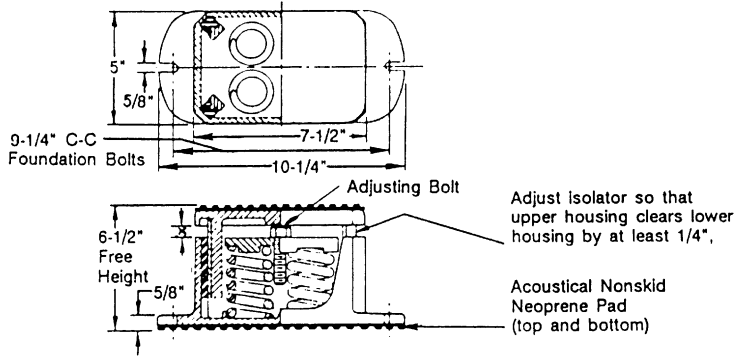

Isolator Type and Size	Maximum Load (Lbs)	Deflection (Inches)	Spring Color Coding
CT-4-25	1,800	1.22	Red
CT-4-26	2,400	1.17	Purple
CT-4-27	3,000	1.06	Orange
CT-4-28	3,600	1.02	Green
CT-4-31	4,400	0.83	Gray
CT-4-32	5,200	0.74	White

**Type CT-7**  
**Spring Isolators**

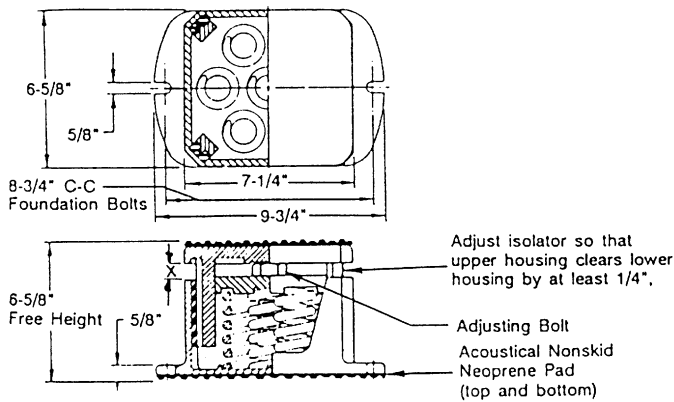

Isolator Type and Size	Maximum Load (Lbs)	Deflection (Inches)	Spring Color Coding
CT-7-25	3,150	1.22	Red
CT-7-26	4,200	1.17	Purple
CT-7-27	5,250	1.06	Orange
CT-7-28	6,300	1.02	Green
CT-7-31	7,700	0.83	Gray
CT-7-32	9,100	0.74	White

**Note: Each type CT-7 Spring Isolator has 7 Springs**

# General Information

Figure 10 - Typical Spring Isolator and Construction  
(Continued)

Isolator Type and Size	Maximum Load (Lbs)	Deflection (Inches)	Spring Color Coding
CT-12-25	5,400	1.22	Red
CT-12-26	7,200	1.17	Purple
CT-12-27	9,000	1.06	Orange
CT-12-28	10,800	1.02	Green
CT-12-31	13,200	0.83	Gray
CT-12-32	15,600	0.74	White

## Type CT-12 Spring Isolators

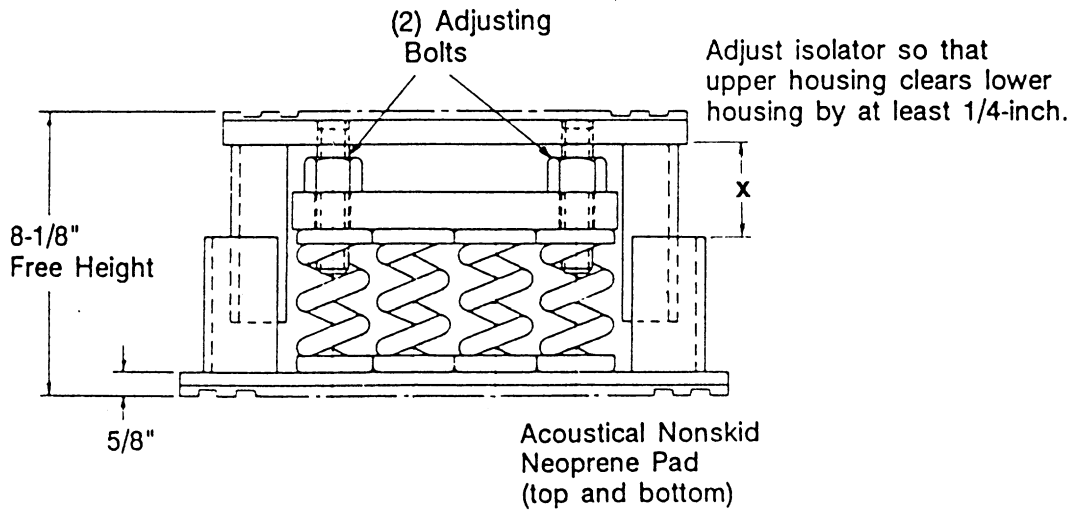
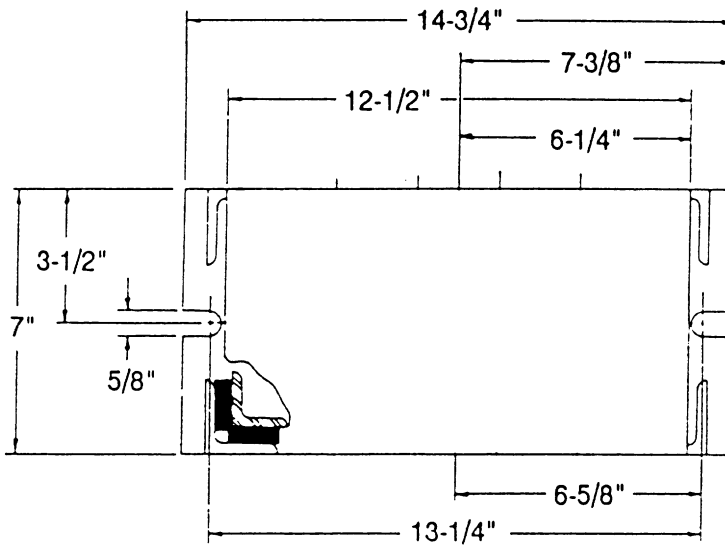

# General Information

---

## Unit Leveling

Follow the instructions outlined below and illustrated in Figure 11 to determine whether or not the chiller is set level.

1. Measure an equal distance up from each foot of the chiller and make a punch mark at each measured distance.
2. Suspend a clear plastic tube along the length of the chiller as shown in Figure 11.
3. Fill the tube with water until the level aligns with the punch mark at one end of the chiller; then check the water level at the opposite mark.

If the water level does not align with the punch mark, use full-length shims to raise one end of the chiller until the water level at each end of the tube aligns with the punch marks at both ends of the chiller.

4. Once the unit is level across its length, repeat Steps 1 through 3 to see if unit is level across the the width.

**Figure 11**  
**Checking Unit Levelness**

