

- UCP2 = name assigned to 2nd-generation microprocessor control system for Trane heavy-refrigeration water chillers.

Term UCP = unit control panel. Refers to the panel itself, all internal components and all peripheral devices needed for its proper operation (sensors, relays, communication links, etc.)

System presently applied to:

- Model CVHE 230-1250 ton CenTraVac (3-stage centrifugal chillers)
- Model CVHF 650-1250 ton CenTraVac (2-stage centrifugal chillers)
- Model RTHB 130-450 ton Series R CenTraVac (helical-rotary chillers)
- Model ABSC Absorber (single-stage absorption chillers)
- Model ABTE Absorber (2-stage absorption chillers)

- This course covers CVHE, CVHF, RTHB, ABSC and ABTE units.
- UCP2 is the brain' of the chiller system. Evolved from UCP-695 through customer feedback about what they want a unit-level chiller control system to do.



Introduction



- * **Control System Overview**
- * **Cruising the Menu - Reports - (Hands on)**
- * **Cruising the Menu - Factory Operational Settings - (Hands on)**
 - **Operator Settings Group**
 - **Service Settings Group**
 - **Field Startup Group**
 - **Machine Configuration Group** *- Set up first on initial startup*
- * **Tests, Diagnostics, Logging and Bubble Chart**
- * **Module Input / Output Values and Component Description**
- * **Basic Wiring Diagrams (Overheads)**

2

- This slide shows the overall organization of this course. Read through each item and briefly explain each.
- What a good chiller control system should do:
 - Produce chilled water at setpoint when needed
 - Protect the chiller
 - Keep the chiller on-line as long as possible during adverse operating conditions (This is where the term "Adaptive Control" comes in. The control system adapts chiller operation to changing conditions in the system to keep it performing.)
 - Detect refrigerant loss (UCP2 allows monitoring of equipment room refrigerant concentrations at the chiller and/or back to a Tracer BMS at a remote location.)



System Overview



- **Innovations Since UCP1 (UCP-695)**
- **Panel Layout**
- **Control Module Description**

3

- The “Overview” portion of this course is divided into the three areas shown on this slide.
- The first generation Trane microprocessor control system is officially called the UCP-695, although many people refer to it as the ‘micro panel’ since no earlier CenTraVac control panel used microprocessor control. Now that there are two micro systems in existence, we need to be careful that people know which system we are referencing.
- To keep things simple in this class, we will always refer to the older UCP -695 as the ‘UCP1’ and to the current system as ‘UCP2’.

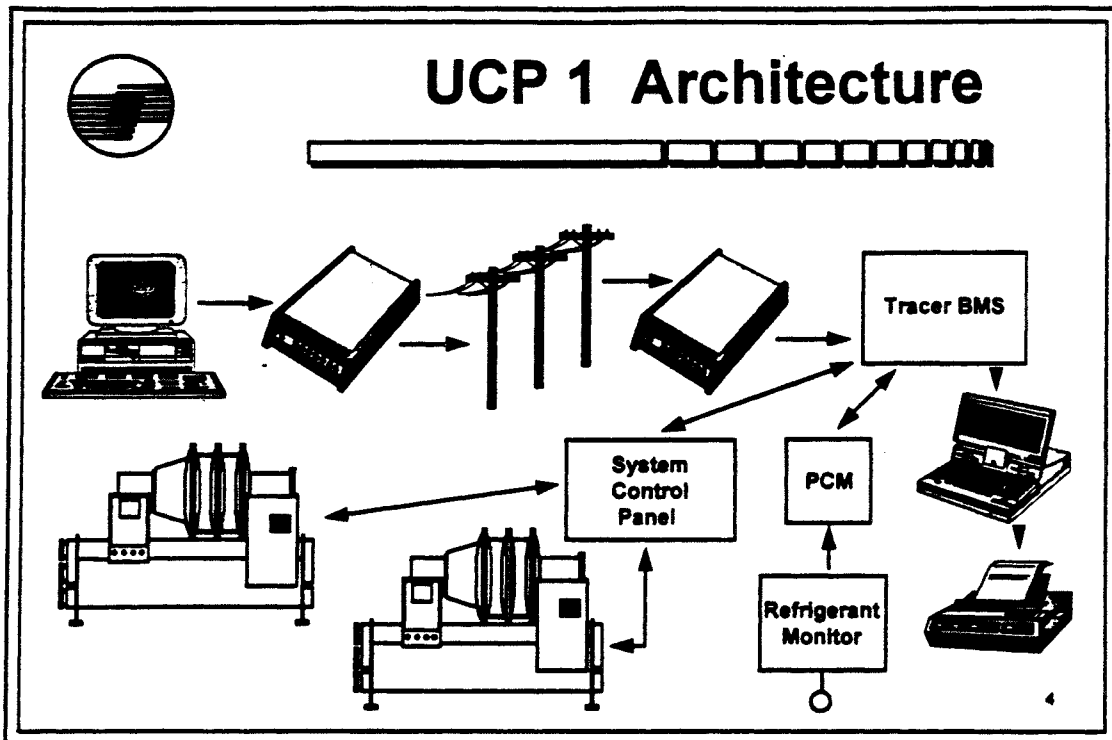

- UCP1 required a Trane SCP (System Control Panel) in order to communicate with higher-level devices such as the Trane Tracer or other generic building management systems (BMS).
- With UCP1, a programmable control module (PCM) was needed to allow a device such as a refrigerant level monitor to communicate with a Tracer or a generic BMS.
- Also with UCP1, one unit control module (UCM) housed all chiller functions. If one function failed, the entire control system had to be replaced.

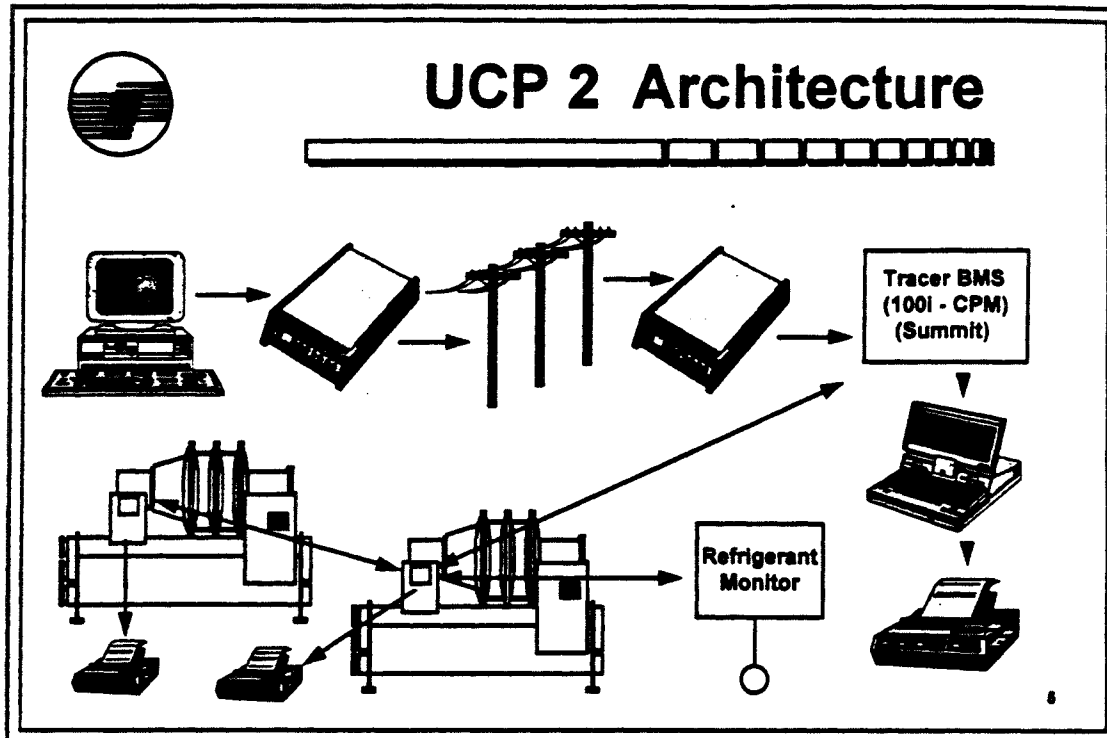

- UCP2 will receive input directly from same-level or lower-level devices and report to a higher-level device (e.g., Tracer) through a direct communication link (no SCP needed).
- Adaptive Control is also used at the Tracer (building) level to insure that system chilled water supply is maintained, even if it is necessary to take a chiller down.
- Explain that when you refer to a 'BMS in this course you will use the Trane Tracer trademark name but that when you say Tracer, you are including all other types of BMS.
- The UCP2 can output reports directly to a printer within 50 feet of the chiller and/or to a printer at system level (Tracer) at a remote location.
- UCP2 can accept equipment room refrigerant concentration level data directly from a refrigerant monitor and/or report the data back to the system level BMS.

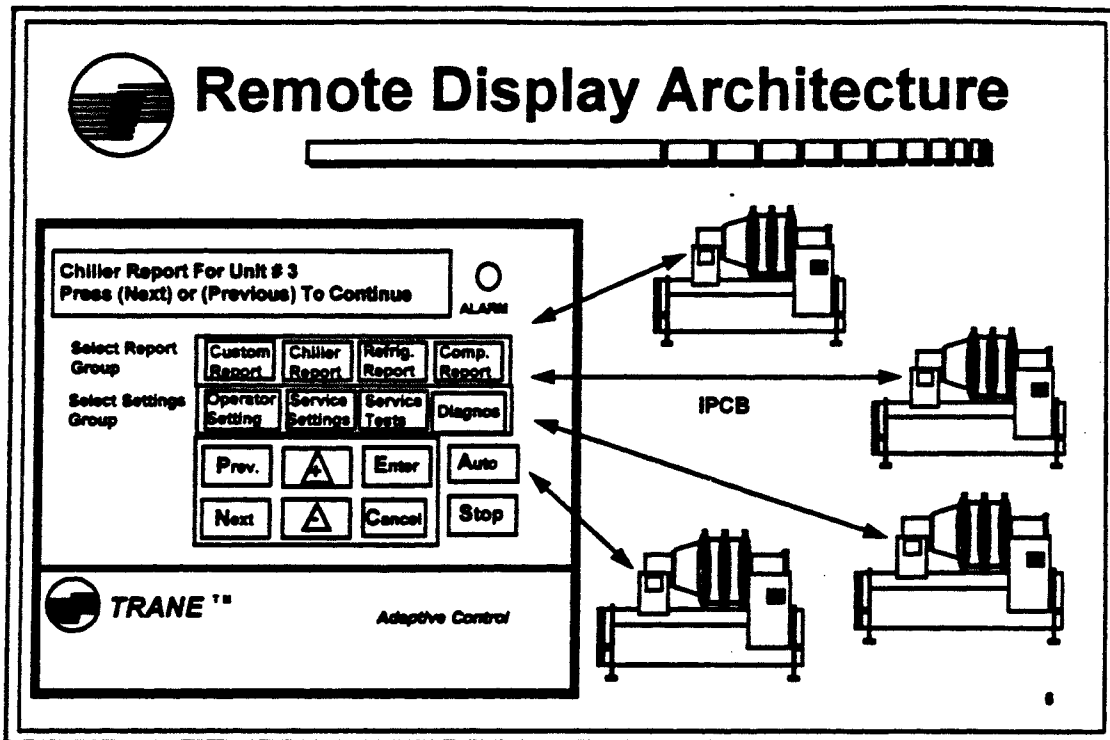

- Up to four UCP2-equipped chillers can be controlled from a remote mounted display at any location within 1,500 feet of the chillers.
- This is kind of a "poor mans" automated chiller plant control system.
- Communication between four chillers and a remote display requires four sets of twisted-pair wire (one from each chiller) and a interprocessor communication link buffer (IPCB) board in each chiller control panel.
- Remote control of multiple chillers is discussed in more detail later in this program.

*can do anything chiller control panel
can do except reset a latching fault*

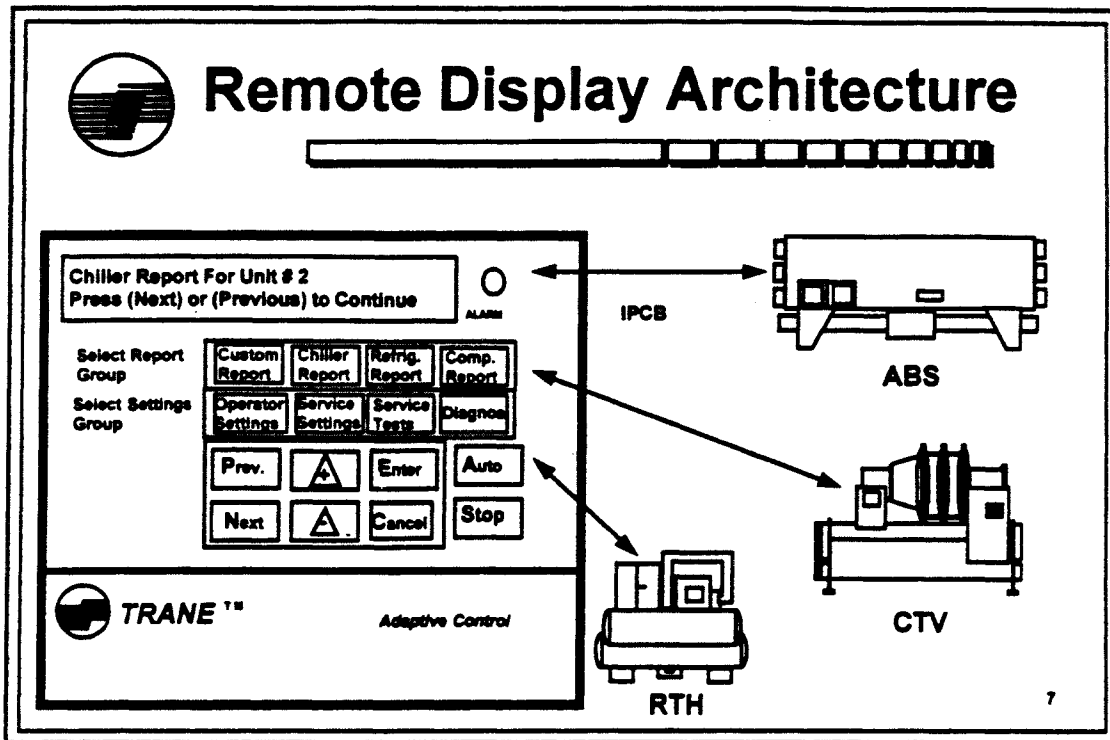

- The remote display can talk to different types of chillers, as long as they are equipped with a UCP2-level control system.
- The UCP2 system software in the remote panel has to be programmed to recognize the type of chiller (RTHB, CVHE, CVHF, etc.) it is communicating with on each twisted-pair link.
- If one remote display were used as shown in this slide to address centrifugal, rotary and absorption chillers, a special display overlay would be needed since the nomenclature on the display is different for absorbers.



UCP 2 Innovations



- * **Modular Design**
- * **Clear Language Display (CLD)**
- * **Remote Clear Language Display**
(Max. 1,500 Ft. / 4 Units Max. / 4 IPCBs / 4 Twisted-Pair Wires)
- * **More Input / Output Options Included** *5000' / 100' / 100'*
- * **Starter Module (Unit-Mounted or Remote)**
- * **Stepper Drive Motor / Inlet Guide Vanes (ctv)**
- * **Stepper Drive Motor / Expansion Valve (rth)**
- * **Variable Speed Drive Compressor Motor (ctv)**

UCP1 Vs. UCP2 Comparison:

- Modular design means reduced parts costs and flexibility for UCP2 - individual module prices are lower than old all-in-one UCM and features can be added as needed.
- All information provided by the UCP2 display is presented in clear language (i.e., English, French, German, etc.) rather than in code as with UCP1.
- UCP2 is upgradeable to new software versions. Only need to change a chip.
- Many features that were costly options for UCP1 are standard on UCP2. All that is required is that they be enabled from a menu. Most other optional features can be provided with the purchase of only one additional electronic module.
- UCP2 has more precise capacity control. Stepper actuator motors for guide vanes and expansion valves do not use limit switches. The control system knows chiller loading condition at all times.
- UCP1 needed a System Control Panel (SCP) to control chillers remotely or access multiple chillers. UCP2 can be controlled by an inexpensive remote display panel or can talk direct to a Tracer.
- UCP2 brings a higher level of motor and compressor protection, including improved motor winding and oil pressure protection systems and simplified wiring between CTV motor terminal box and remote-mounted starter panel.

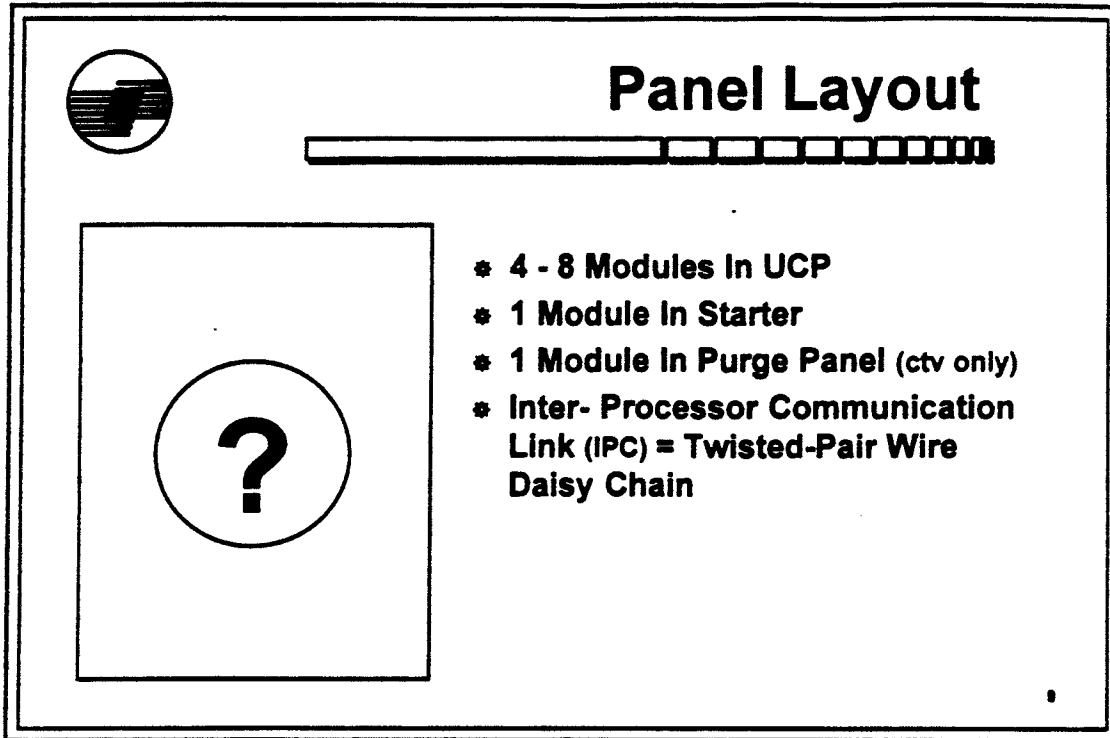

- UCP2 is modular by function. The panel will contain anywhere from four to eight electronic modules, depending on the type of chiller and features ordered. One module is mounted in the motor starter panel and one in the purge control panel on centrifugal chillers. If the chiller does not use a Trane-provided starter, the starter module is mounted in an extension of the UCP2.
- The Interprocessor Communications Link (twisted-pair wire) provides the communication path between modules. This link is referred to as the “IPC Link”.
- The Purifier Purge™ system used on low pressure chillers is controlled and monitored at the UCP2 display panel. If a UCP2-based purge is retrofitted on a non-UCP2 chiller (competitive or Trane) the purge utilizes a purge-mounted UCP2 interface that provides for independent purge operation.
- All twisted-pair wire must be grounded in the UCP2 panel.
- In the examples that follow of module input and output functions, centrifugal modules are used as models. The I/O points and descriptions may vary for RTHB units. These will be discussed further when the class discusses the chiller wiring diagrams in detail.



Module Designations

CTV Panel is Vertical
RTHB is Horizontal

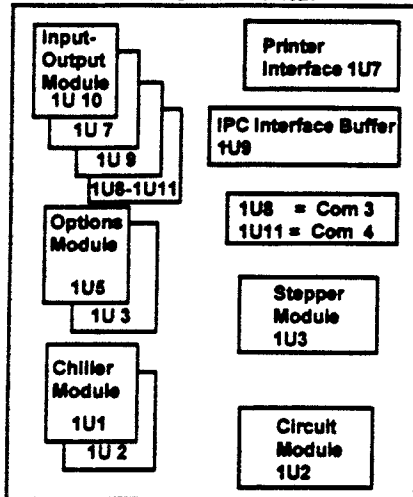

- * Chiller Module (1U1)
- * Circuit Module (1U2)
- * Stepper Module (1U3)
- * Clear Language Display (1U4)
- * Options Module (1U5)
- * 4 Interface Modules (1U6 - 9)
- * I.O. Module (1U10)
- * Starter Module (2U1)
- * Purge Module (3U1) - (ctv)
- * Phase Sequence Monitor (3U1) - (rth) *Main ductors RTH*

10

- The first digit of an electrical component designation indicates its location (i.e., 1U1 = component located inside control panel). These designations are derived from the ANSI wiring system used by Trane. In this system, the first digit of the component designation is used as follows:
1 = Main Control Panel; 2 = Starter Control; 3 = Purge; 4 = Unit-Mounted Device; 5 = Provided By Others
- The individual electronic module designations are:
1U1 = Chiller Module; 1U2 = Circuit Module; 1U3 = Stepper Module; 1U4 = Clear Language Display; 1U5 = Options Module; 1U7 = Printer interface Module; 1U8 = Tracer COM3 Interface; 1U9 = IPC Buffer; 1U10 = Input/Output Module; 1U11 = Tracer COM4 Interface
- The clear language display (1U4) is mounted in the control panel door so that it is visible with panel door closed. All modules except 2U1 and 3U1 are located inside the UCP.
- Since the RTHB is a high-pressure chiller, it has no purge. When RTHB units use a remote-mounted starter, a 3U1 module is mounted inside the motor terminal junction box on the chiller. On the RTHB, this 3U1 module is a phase sequence monitor for the compressor motor instead of a purge control device. This is used because making the wrong electrical connections at the RTHB motor will cause reverse rotation of the compressor, resulting in immediate, catastrophic compressor damage.

never ok power on circuit board to side of panel
always pick up ground at J2

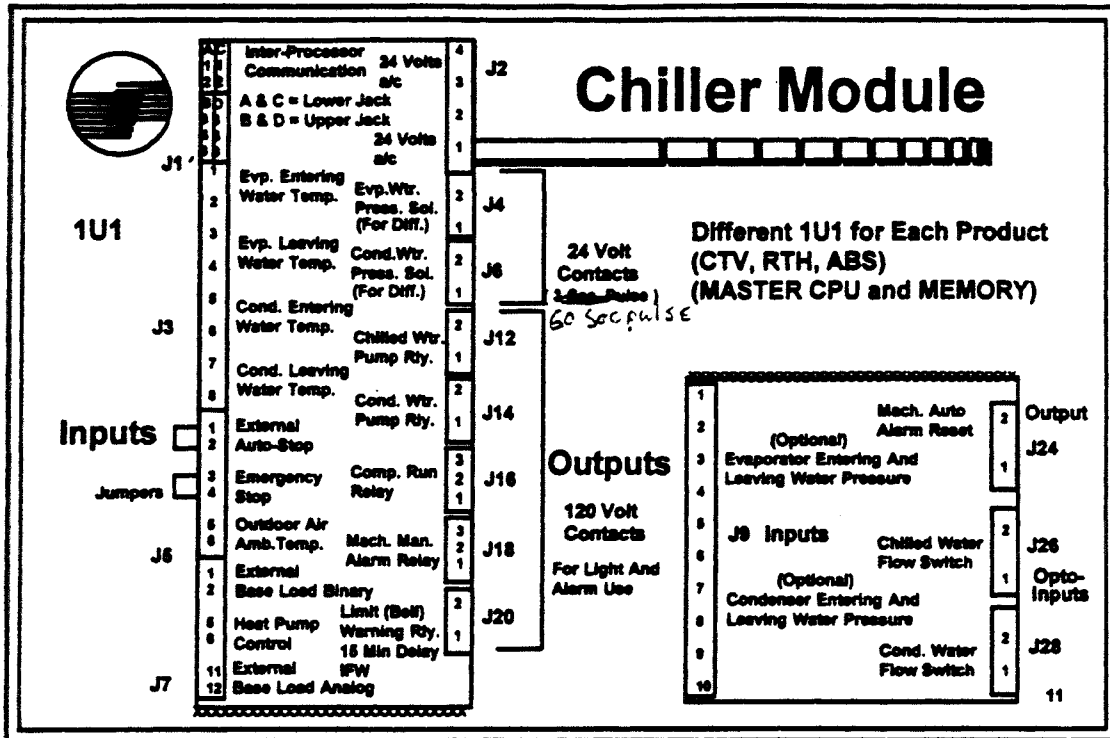

- 1U1 is the “master module”, collecting data, status conditions, diagnostic information, etc. from modules (over the IPC link) from sensors and remote contacts and in turn, communicating commands to other modules.
 - 1U1 performs leaving water temperature and limit control algorithms, trading off chiller capacity against various “limits” that the chiller may be working against.
 - 1U1 checks for valid setpoints and identifies the chiller type for the other modules.
 - 1U1 maintains setpoints in non-volatile memory in the event of a power loss.
 - Low Voltage (<30VAC) Inputs:
 - 24 VAC; IPC link internal, IPC link purge & starter modules; evap. EWT & LWT; cond. EWT & LWT; external auto stop; emergency stop; ambient air CWR; external vane control; heat pump control; evap. water delta P; cond. water delta P
 - High Voltage (>30VAC) Inputs:
 - Evap water flow switch; cond. water flow switch
 - High Voltage (>30VAC) Outputs:
 - Evap. water pressure solenoid; cond. water pressure solenoid; evap. water pump relay; cond. water pump relay; compressor run relay; MMR alarm relay; MAR alarm relay, limit warning relay
- Note: MMR = Machine Manual Reset; MAR = Machine Auto Reset

Outputs - 2 Pins SPST Circuit 3 Pins - SPDT Circuit

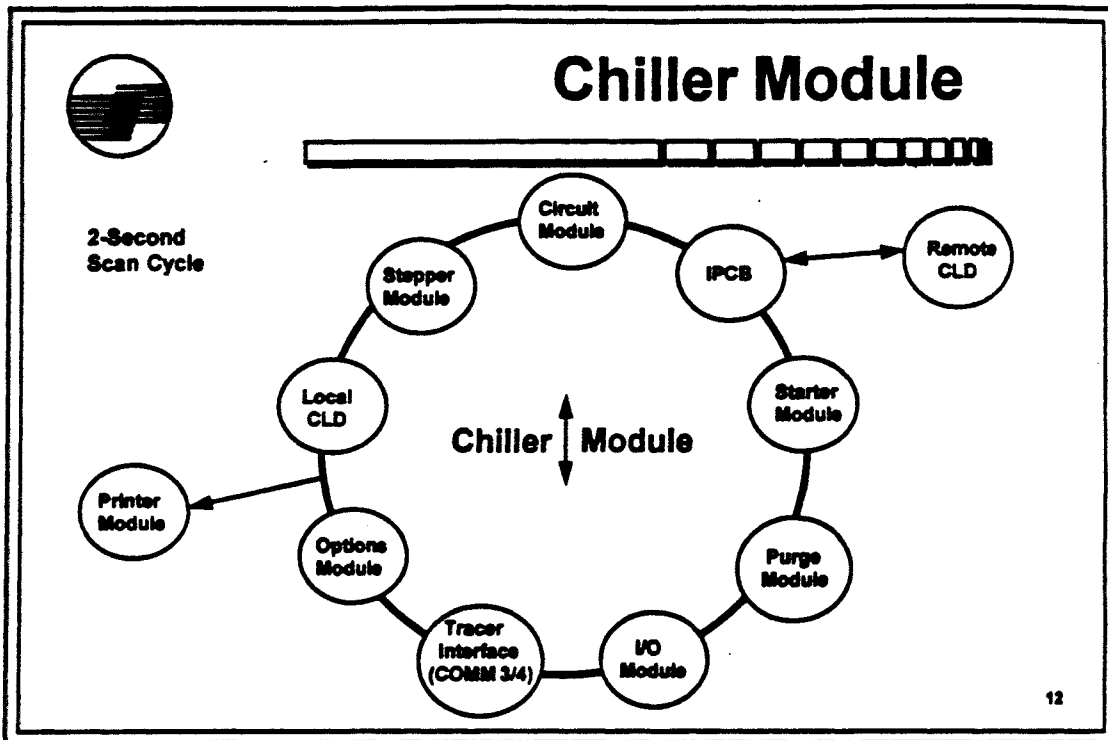

- During operation, the chiller module continuously "scans" the various modules for information over the IPC link. It completes a scan of the system about every two seconds. This includes communication with any remote display used in the system and sending data to the printer.

all Boards read & updated Every 1.7 Sec.

Motor Temp above 165° 15 min cool down before start
 Motor Temp > 365° locks out
 No restart inhibit if Motor Temp below 165°

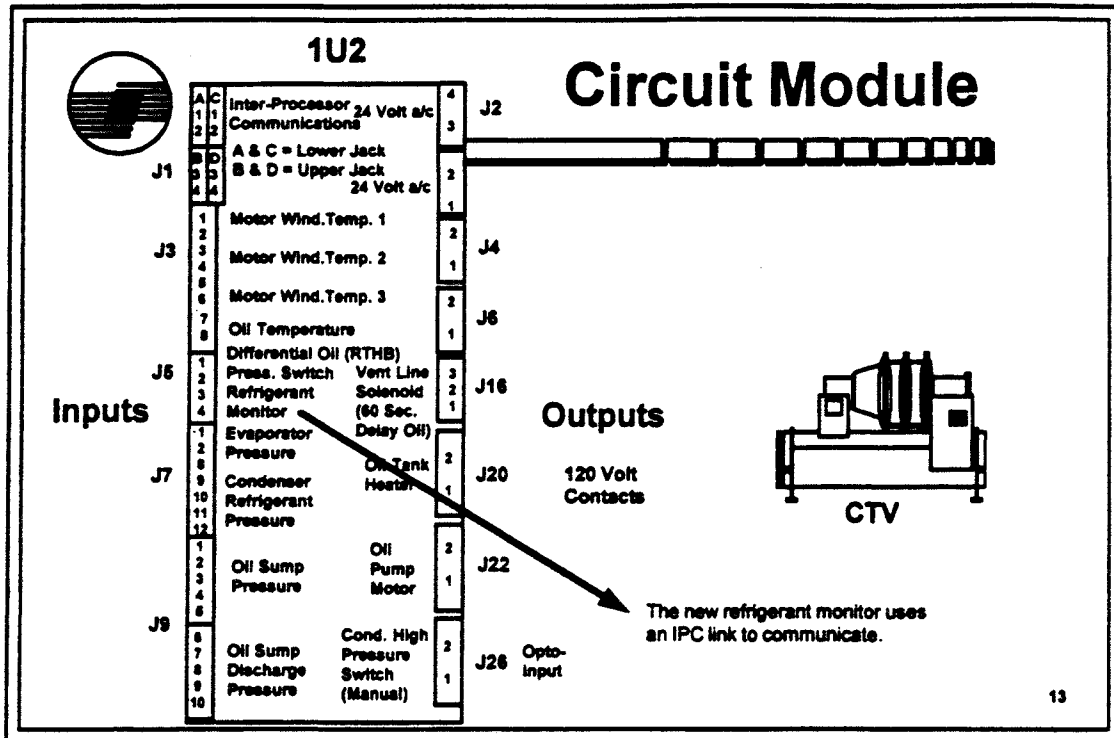

- This module is used to expand the number of inputs and outputs available to the system.
- Low Voltage (<30VAC) Inputs:
 - 24VAC;
 - IPC link;
 - compressor motor winding temp. sensors 1, 2, 3;
 - oil tank temperature;
 - differential oil pressure switch;
 - refrigerant monitor (equipment room refrigerant vapor level in parts-per-million);
 - condenser refrigerant pressure;
 - oil sump pressure;
 - oil pump pressure
- High Voltage, High Amperage (120 VAC) Inputs:
 - High condenser pressure
- High Voltage, High Amperage (120VAC) Outputs:
 - Vent line solenoid valve;
 - oil tank heater;
 - oil pump motor
- The Refrigerant monitor sends a PPM signal to the UCP2. The range is 0 to 100 PPM.
- The oil vent line solenoid remains closed for ~~150~~ seconds, then opens.

60

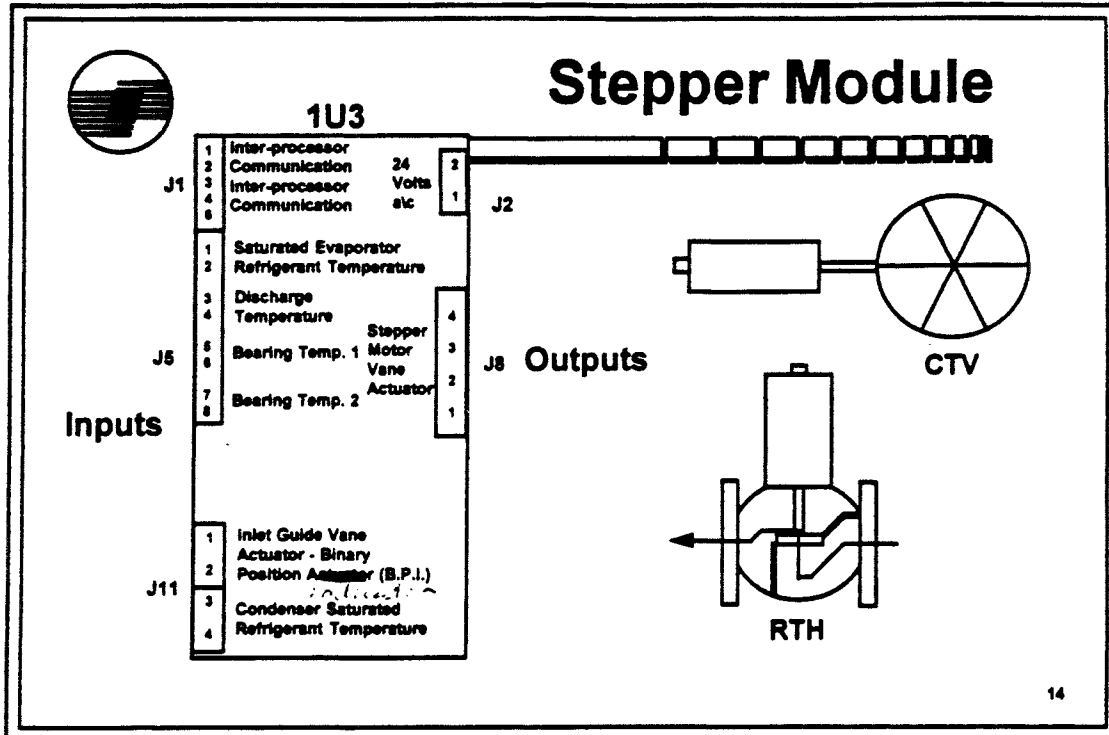

- The main function of the 1U3 stepper module is to drive the inlet guide vane stepper motor (CTV) or electronic expansion valve (RTHB), along with other functions. It does this in response to signals received from chiller module 1U1.
- Low Voltage (<30VAC) Inputs:
 - 24VAC;
 - IPC link;
 - evaporator saturated refrigerant temperature;
 - compressor discharge temperature (optional);
 - bearing temps, 1 & 2;
 - inlet guide vane actuator position;
 - evaporator saturated refrigerant temperature
- Low Voltage, High Amperage (<30VAC) Outputs:
 - Vane actuator stepper motor (EXV stepper motor on RTHB)
 - 50,000 Steps of action

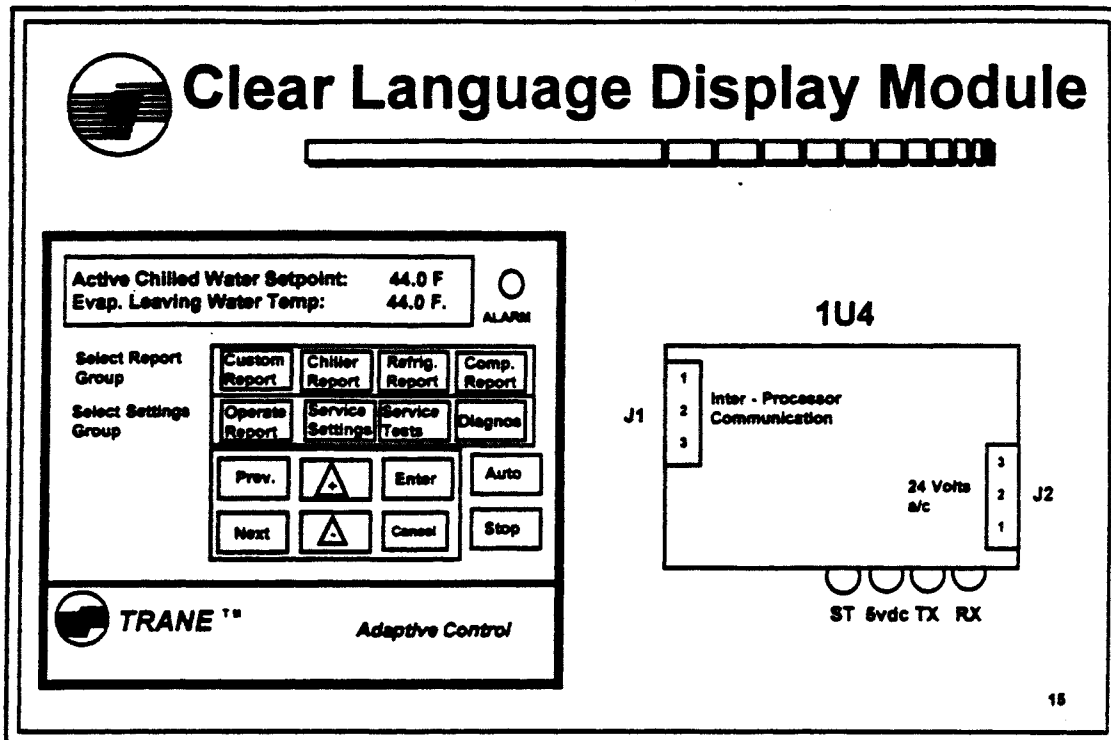

- Referred to in Trane literature as the “CLD” or operator panel.
- In computerize, 1U4 is the “human interface” for the UCP2. It’s the bridge between man and machine. We will not refer to it as the “human interface”, but as the CLD.
- 1U4 is mounted in the control panel door. It is viewed from the front of the panel.
- The CLD allows operator or service personnel to monitor system conditions as it displays chiller data, including chiller operating status, setpoints, operating conditions, unit configuration, purge operating conditions, service and diagnostic settings.
- The UCP is accessed by viewing the 2-line LCD display and pressing combinations of the 16 available keys arranged in a 4 X 4 key matrix on the panel.
- An optional remote display allows chiller operation from as far away as 1,500 feet.
- Four lights are on the bottom inside of the “CLD”. The ST-Light is for self test. During self test light is off. After and everything is ok, light is on
- 5VDC light shows the panel has power.
- RX-TX are communications lights. RX is input and should flash continuously TX is output and should flash occasionally

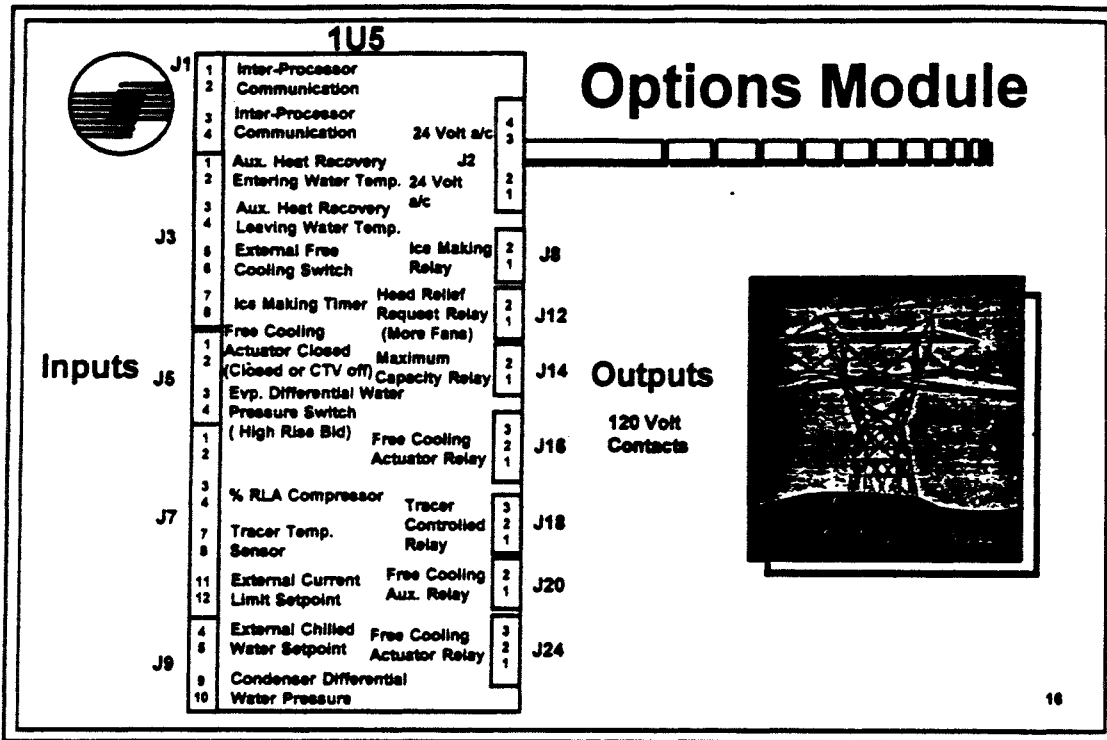

- As it's name indicates, 1U5 provides the control or interface requirements for many of the options available with the UCP2.

- Low Voltage (<30VAC) Outputs:

- Heat recovery actuator;
- % RLA compressor

- High Voltage (>30VAC) Outputs:

- Ice-making relay; head relief request relay;
- max. capacity relay;
- free cooling actuator relay 1 (liquid line valve) ;
- free cooling auxiliary relay;
- free cooling actuator relay 2 (gas line valve)

- Low Voltage (<30VAC) Inputs:

- 24VAC;
- IPC link;
- auxiliary heat recovery EWT;
- auxiliary heat recovery LWT
- external free cooling control;
- external ice-making control;
- free cooling actuator closed;
- evaporator water delta P;
- condenser water delta P;
- Tracer temperature sensor;
- external current limit setpoint;
- external chilled water temp. setpoint (CWT)

J.5

Free Cooling Actuator must BE closed or chiller won't start.



Communication Modules



1U7

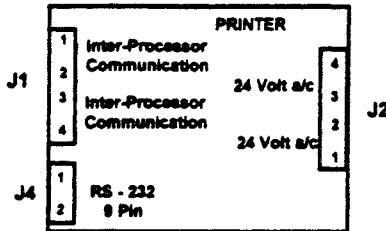

1U7 Printer Module
1U8 & 1U11 Tracer Modules
(PIGGYBACK BOARD)
1U9 IPC Buffer Module
(Remote CLD Only)

1U8 - 1U11

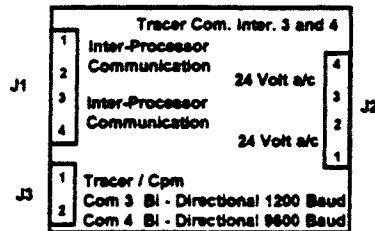

1U9

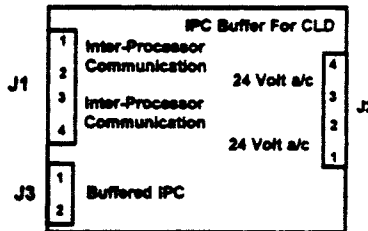

17

- **1U7 - Printer Interface Module:**

Allows a preformatted chiller log to be output at a printer right at the chiller location. Can be programmed using the CLD to print a chiller log on command, at the time of a diagnostic, or on a periodic basis.

- **1U8 - Tracer COM3 Interface:**

Optional module that provides an isolated, 1200-baud, bi-directional serial communication link to a Tracer 100/Tracer i or BAS panels.

- **1U9 - IPC Buffer Module:**

The communication interface between the UCP2 and a Remote CLD. If a remote panel is not used, this module is not required. It must be provided on any chiller (up to 4) talking to a Remote CLD.

- **1U11 - Tracer COM4 Interface:**

Optional module that provides non-isolated, 9600-baud, bi-directional serial communication link to the new Tracer Summit or Tracer i.

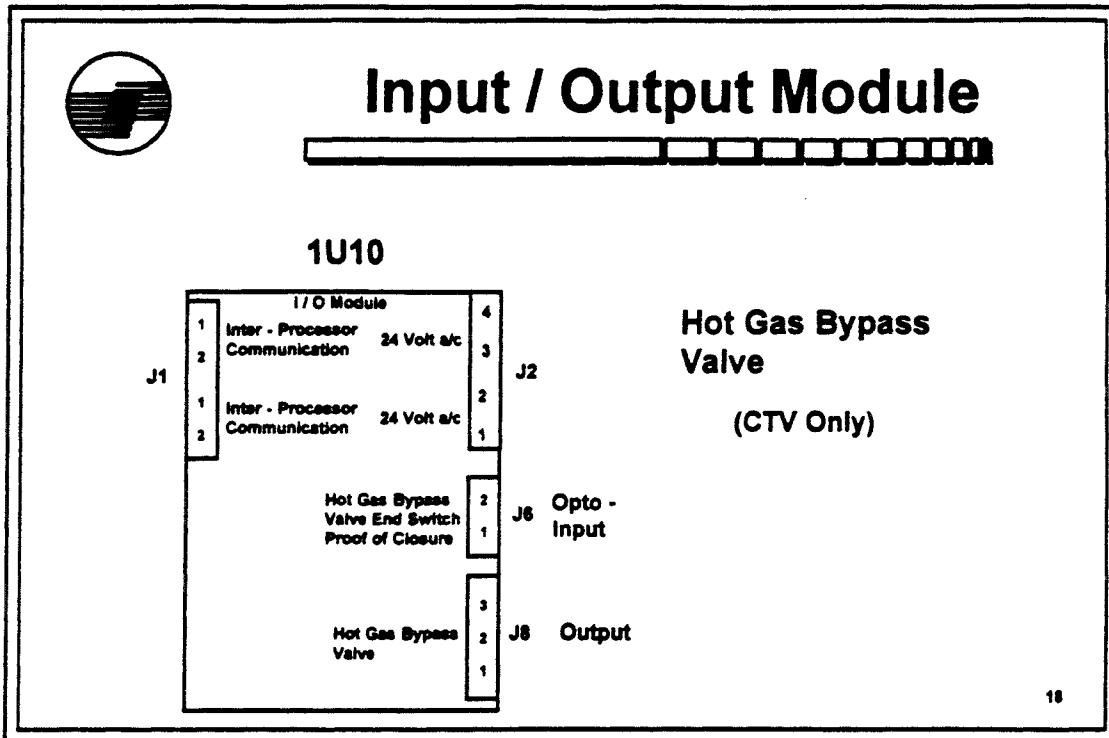

- Provided only when chiller is equipped with hot gas bypass (HGBP) option.
- The I/O Module (1U10) operates the hot gas bypass valve on CVHE and CVHF units in response to signals from stepper module 1U3.
- The module also receives input on HGBP valve position from the HGBP valve end switch.
- Low Voltage (<30VAC) Inputs:
 - 0-10 VDC HGBP valve drive signal
- High Voltage (>30VAC) Inputs:
 - 24 V HBPB valve proof-of-closure signal from valve end switch
- High Voltage (>30VAC) Outputs:
 - HGBP open Triac;
 - HGBP close Triac

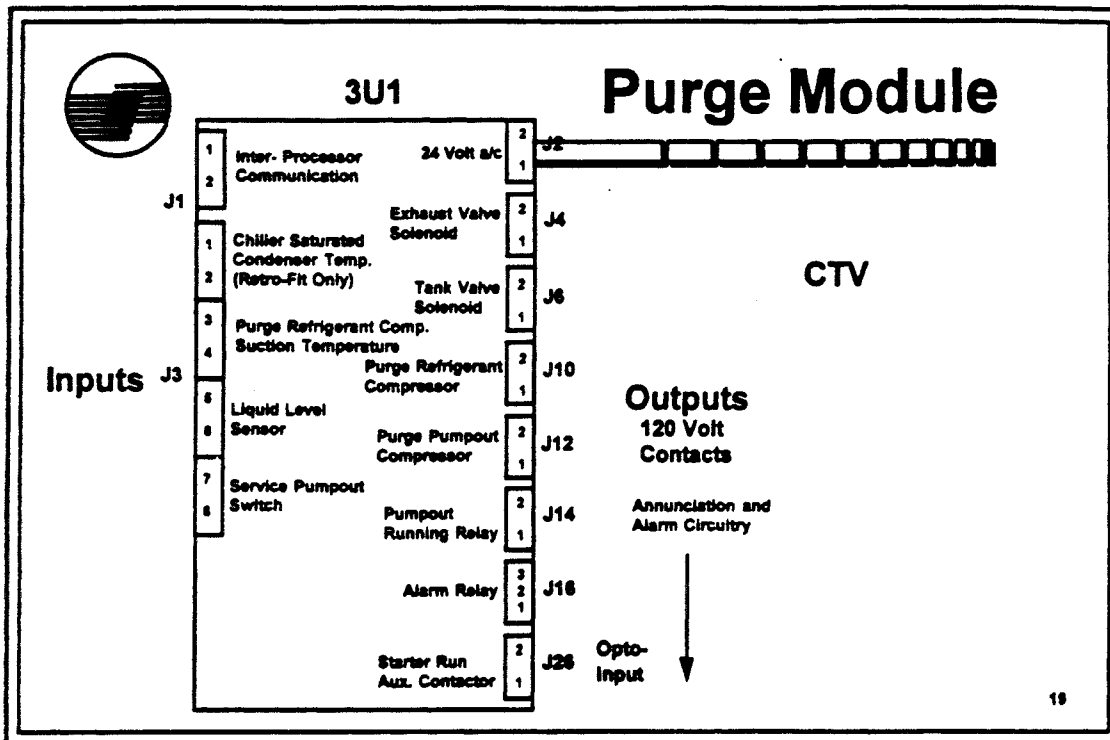

- The purge module (3U1) is provided with the Trane Model PGRC Purifier Purge on CVHE and CVHF chillers. It is located in the purge control panel at the purge. It provides all inputs and outputs for the UCP2 to control purge operation.

- **Low Voltage (<30VAC) Inputs:**

24 VAC; IPC link to chiller module;
 purge refrigeration compressor suction temperature;
 purge tank liquid level sensor;
 service pumpout switch

- **High Voltage (>30VAC) Outputs:**

Exhaust valve solenoid; tank valve solenoid;
 purge refrigerant compressor;
 purge pumpout compressor;
 purge pumpout running (Tracer); purge alarm

- **IMPORTANT:**

Although the RTHB chiller does not have a purge, it does utilize a device designated as 3U1 in certain cases. When the RTHB chiller uses a remote starter, a phase-sequence monitor (3U1) is mounted in the unit-mounted motor terminal junction box. Proper phase-sequencing is critical to prevent reverse compressor rotation which will cause extensive damage almost instantly. Although the starter module provides this protection, if the starter is remotely mounted, it is possible to cross leads from the starter to the compressor motor.

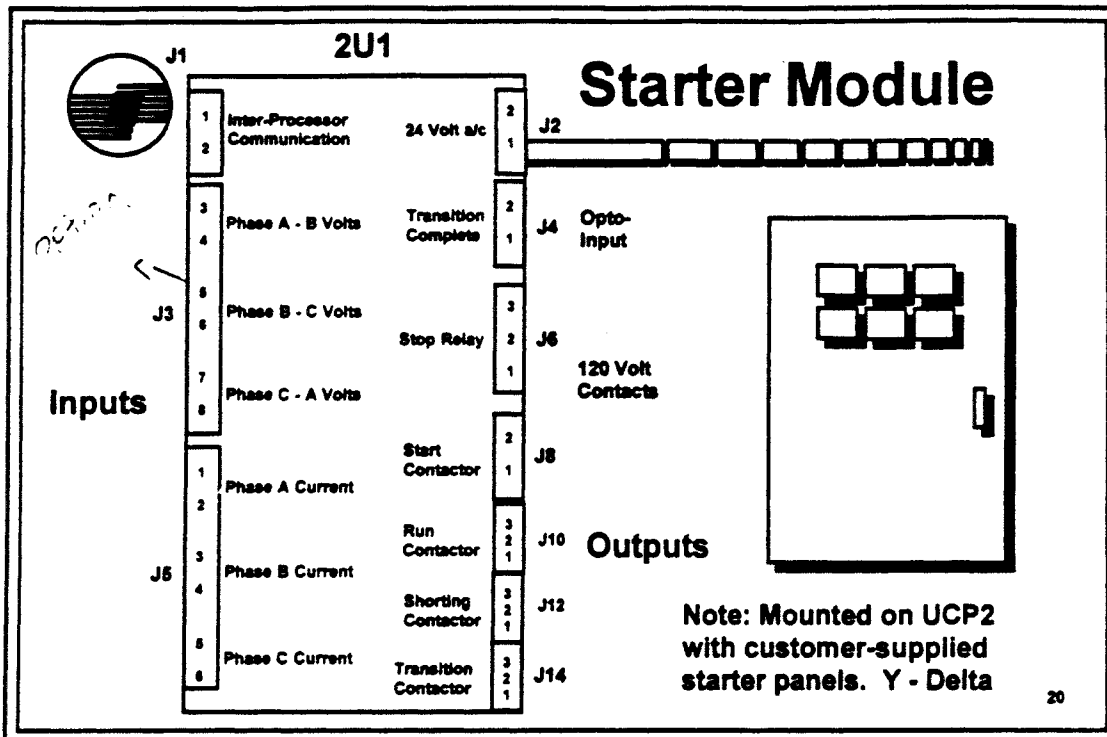

- The starter module (2U1) is present in all Trane-provided starter panels, whether unit-mounted or remote. For CTV's, if no Trane starter is provided and the customer is providing the starter instead, 2U1 is mounted in an extension of the unit control panel. It is still designated as 2U1, however. For RTHB units, 2U1 is always located in the starter panel.
- 2U1 controls the starter when starting, running and stopping compressor motor and provides an interface to all types of starters and AFD's (adjustable frequency drives).
- 2U1 provides compressor motor protection for running overload, phase reversal, phase loss, phase unbalance and momentary power loss.
- Low Voltage (<30VAC) Inputs:
 - 24 VAC; IPC link to chiller module; phase voltages (optional); phase currents; solid-state heat sink temperature (optional); starter driver fault
- Low Voltage (<30VAC) Outputs:
 - Speed signal output (0-10 VDC - optional)
- High Voltage (>30VAC) Inputs:
 - Transition complete (CTV only)
- High Voltage (>30VAC) Outputs:
 - Stop relay; starter relay; run relay; shorting relay; transition relay; shunt trip relay

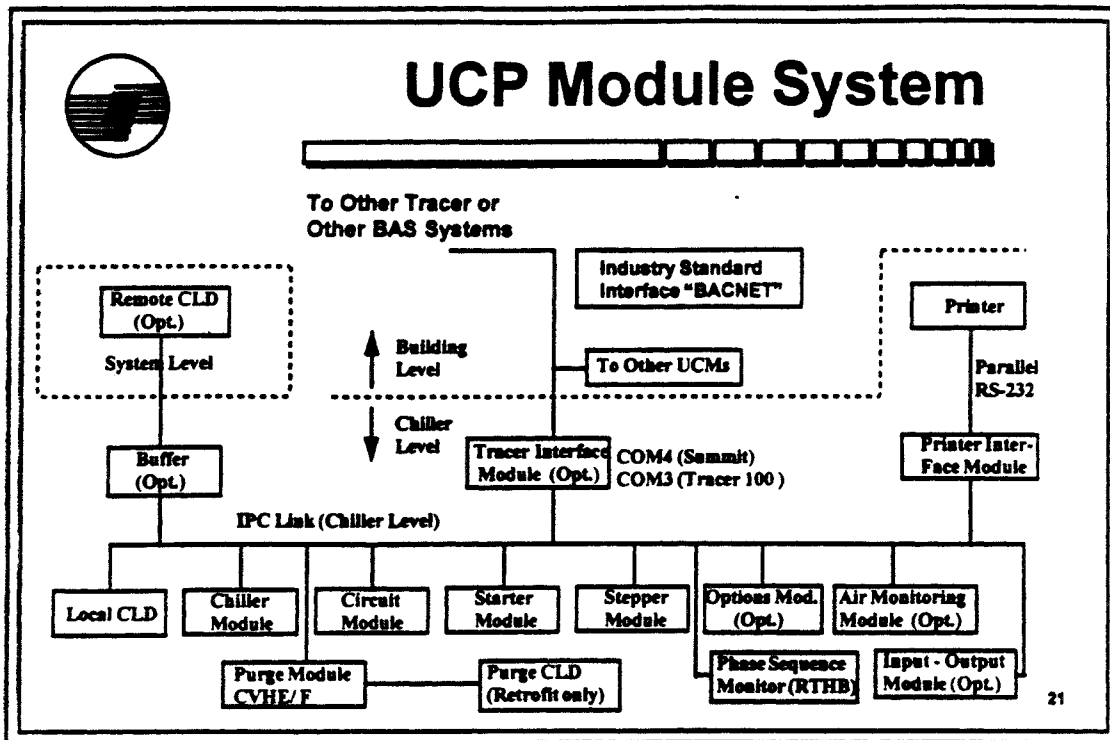

- This slide provides a summary of module organization and function and identifies their communication hierarchy (i.e., BMS level, System level, Unit level).
- All modules shown are at unit-level, either in the UCP2 panel, in the purge panel, starter panel or in the immediate vicinity of the chiller (printer). A printer could also be located at the Tracer or other BMS level.
- A remote clear language display would be considered to be located at system (i.e., chilled water system) level.
- A Tracer or other BMS and their communication links to unit control modules (UCMs) on other HVAC or other types of equipment are on the BMS or building level. In addition to chillers, the BMS could be controlling air handlers, VAV systems, lighting and electrical equipment, etc.

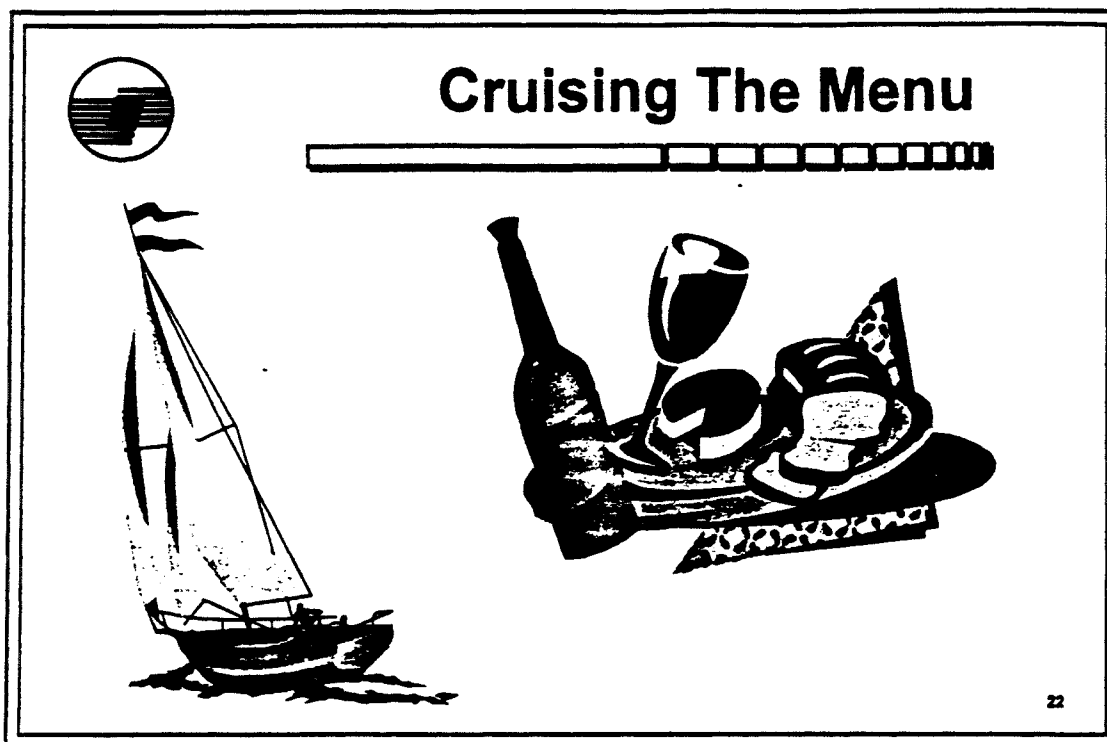

- This concludes the “Overview” portion of this course. The next portion of this program examines the UCP2 menu structure and functions of the clear language display (CLD) and operator control keypad.
- At this point, it is recommended that the instructor present a demonstrator clear language display to the students. The use of this device will provide a hands-on component to the class which is needed to help make this material easier assimilate.

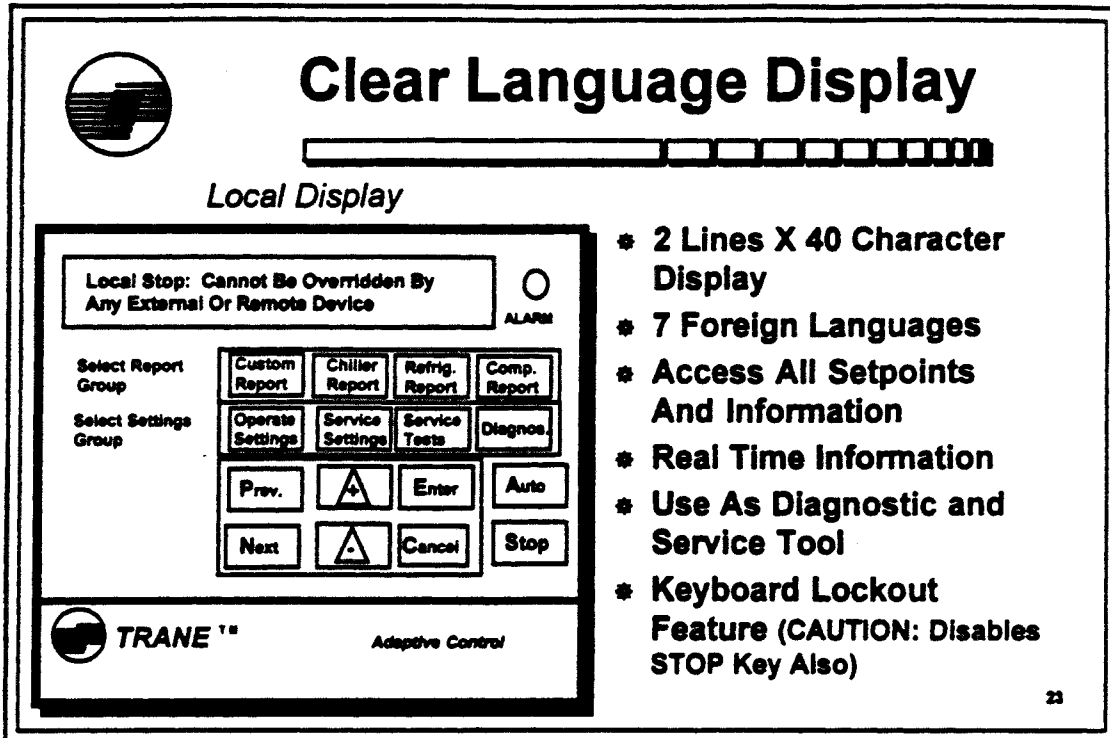

- The liquid crystal display screen and the 16-key membrane keypad together are referred to as the “Clear Language Display” or abbreviated as the “CLD”.
- The CLD mounted in the door panel of the UCP2 is the “local” CLD. An identical, remote CLD is available also.
- The chiller is controlled by pressing appropriate key combinations on the keypad. It provides access to control, setpoints, and setup information.
- All settings and adjustments are made from the menus at the CLD. The 2-line, 40-character LCD screen will display the chiller data. The display screen backlights anytime a key is pressed.
- All information is stored in non-volatile memory in chiller module.
- An “Alarm” LED is located on the face of the CLD to indicate a manual reset diagnostic condition has locked out chiller operation and requires manual reset at the chiller (local) CLD.
- Seven foreign languages are available on the CLD.
- Keyboard use can be locked out at the Service Setup Menu. If keys are non-functional, contact a Trane service technician.



Clear Language Display

(Continued)



Remote Display

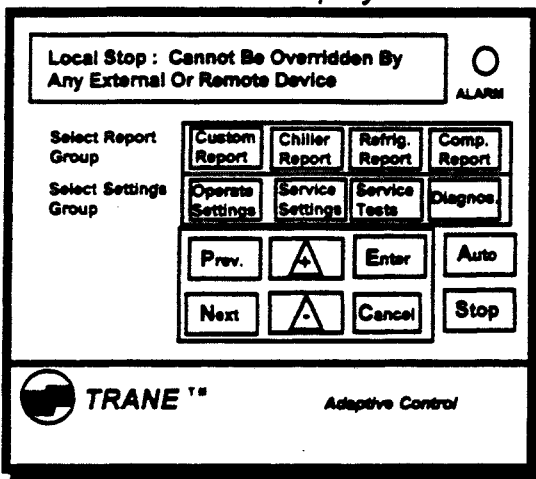

- * Transparent Communication With Up To 4 UCP2 Chillers Of Any Type
- * Uploads / Downloads Data To / From Chiller Module
- * Full Control Ability
- * Local And Remote Networking Ability (Tracer)
- * Alarm / Informational LED
 - Flashing = MMR Diagnostic
 - Steady = Manual Test Mode

24

- All variable (i.e., temperatures, setpoints, pressures, etc.) will be updated every two seconds while it is being displayed.
- The remote CLD can be located up to 1,500 feet away from the chiller(s).
- The remote CLD will perform all of the functions of the local CLD except reset of certain latching diagnostics.
- Each chiller controlled by a remote CLD must have IPC Buffer module 1U9 installed in the UPC.
- The alarm LED (light-emitting diode) will light only if a diagnostic has occurred that requires an operator to manually reset the controls in order to restore normal chiller operation.



Clear Language Display

(Continued)

Keypad Layout

Stop

○ ALARM

Select Report Group
 Select Settings Group

Custom Report	Chiller Report	Refrig. Report	Comp. Report
Operate Settings	Service Settings	Service Tests	Diagnose
Prev.	▲	Enter	Auto
Next	▼	Cancel	Stop

- **4 Report Groups**
 - Custom Reports
 - Chiller Reports
 - Refrigerant Reports
 - Compressor Reports
- **4 Settings Groups**
 - Operator Settings
 - Service Settings
 - Service Tests
 - Diagnostics
- **Group Headings**
 - Enable/Disable at Service Setup Menu For Security

TRANE™
Adaptive Control

• The CLD displays all chiller operating data and provides access to controls, setpoints, setup and diagnostic information.

• **4 Report Group Keys (Cannot change settings in reports)**

- Custom report: Operator-selected data from chiller, refrigerant and compressor reports.
- Chiller report: Current chiller operating status, water temperatures and operating setpoints.
- Refrigerant report: Refrigerant-related data; pressures, temperatures, purge and equipment room refrigerant monitor data.
- Compressor report: Compressor data; operating time, starts, oil system data, inlet guide vane position & bearing temps (CTV), and electrical data.

• **4 Settings Group Keys**

- Operator settings - View and change operator-level chiller and purge operating setpoints.
- Service settings - View and change technician-level field setup data and factory configuration settings.
- Service tests - Used to test or override chiller operation or subsystems.
- Diagnostics - Used by technician to view historical and active diagnostics and clear diagnostic lockout conditions to resume normal operation.



Clear Language Display

(Continued)

Keypad Layout

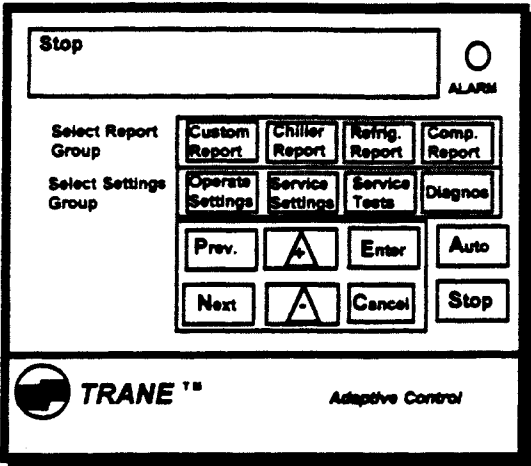

*** Data Control Keys**

- Previous
- Next
- Plus
- Minus
- Enter
- Cancel

*** Auto**

- Chiller Auto Operation

*** Stop**

- Press Once For "Manual" Stop (Timed Shutdown)
- Press Twice In 5 Secs For "Panic" Stop (No Unloading)

TRANE™
Adaptive Control

- **DATA CONTROL** keys (for manipulating settings and data)
- **Previous/Next:** Use to scroll forward or backward through report items or menus. Screen will wrap back to the top or bottom of the menu when the end or beginning of the group is reached.
- **Plus/Minus:** Use to change setpoints up (+) or down (-). Can only be done when in "Settings Groups". Second line of screen will be "Press (+) (-) to Change Setting". Holding (+) or (-) key down will change setting at rate of 10 counts/second for first 10 seconds, then rate increases to 100 counts/second.
- **Enter/Cancel:** Use to enter new setpoints into memory. Enter must be pressed to store any new setting in memory. Use cancel if new setting should not be stored. This can only be done when in "Settings Groups".
- Settings or sensed data are updated on the screen every 2 seconds.
- **AUTO Key** - Allows chiller start on a call for cooling based on differential-to-start setpoint. Chiller stops when cooling load is satisfied. Chilled water pump continues to run and chiller module monitors LCWT to restart chiller.
- **STOP Key** - Selects "manual" stop of chiller operation. Chiller still goes through normal shutdown sequence, except that chiller water pump stops also.
- **IMPORTANT:** Pressing STOP two times within 5 seconds initiates "emergency stop". Same as normal stop except compressor motor stops immediately and chiller is not unloaded as in normal stop sequence.

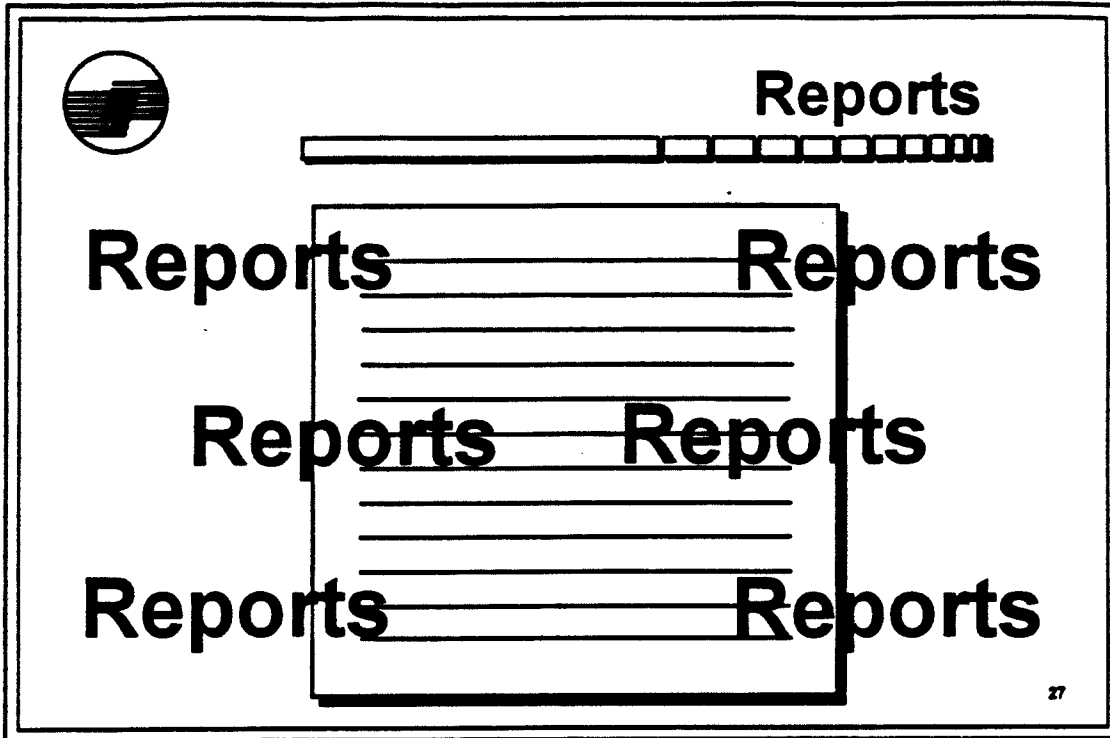

- Reports allow the chiller operator to view chiller operating conditions, settings and setpoints and provide a means of automatically generating a log of selected data either periodically or on demand.

- There are 4 Report Types:

- Custom Report
- Chiller Report
- Refrigerant Report
- Compressor Report

- Each individual point of any report can be viewed at the CLD at any time by pressing the desired report group key and using the Next and Previous keys to scroll through the report items as needed.

-

- Note: Setpoints cannot be changed when viewed from within a report.

Custom Reports

User Defined Custom Reports
Press (Next)(Previous) To Continue

ALARM

Select Report Group	Custom Report	Chiller Report	Refrig. Report	Comp. Report
Select Settings Group	Prev.	Next	Auto	

- * Can Contain Maximum of 20 Records Customized By You
 - Use + And - Keys To Add Or Delete Records
- * Local / Remote CLDs Can Display Different Records / Commands Simultaneously
 - 2 People Can Be Viewing / Entering / Deleting Records

Will Not Loose Memory on Power Failure

Will Not Print Out- View Only

•The operator can create a “Custom Report” by selecting individual points from the Chiller, Refrigerant and Compressor Reports. In this manner, data that is critical to the specific job can be viewed in one menu.

•When the Custom Report key is pressed, the report heading will display as shown on this slide. If no items have been selected for this report, pressing Next or Previous will display:

**“No items are selected for Custom Report -
See Operator’s Manual to select entries”**

•The Custom Report can contain up to 20 items. To add an item to the Custom Report, view the item in its normal report location, then press the (+) key.

•To remove an item from the Custom Report, view the item in the Custom Report and press the (-) key.

•If an attempt is made to add a 21st item to the report the display will indicate:
“Custom Report is Full, Report Not Added”

•If an attempt is made to add an item already in the report the display will indicate:

“Report Already In Custom Menu

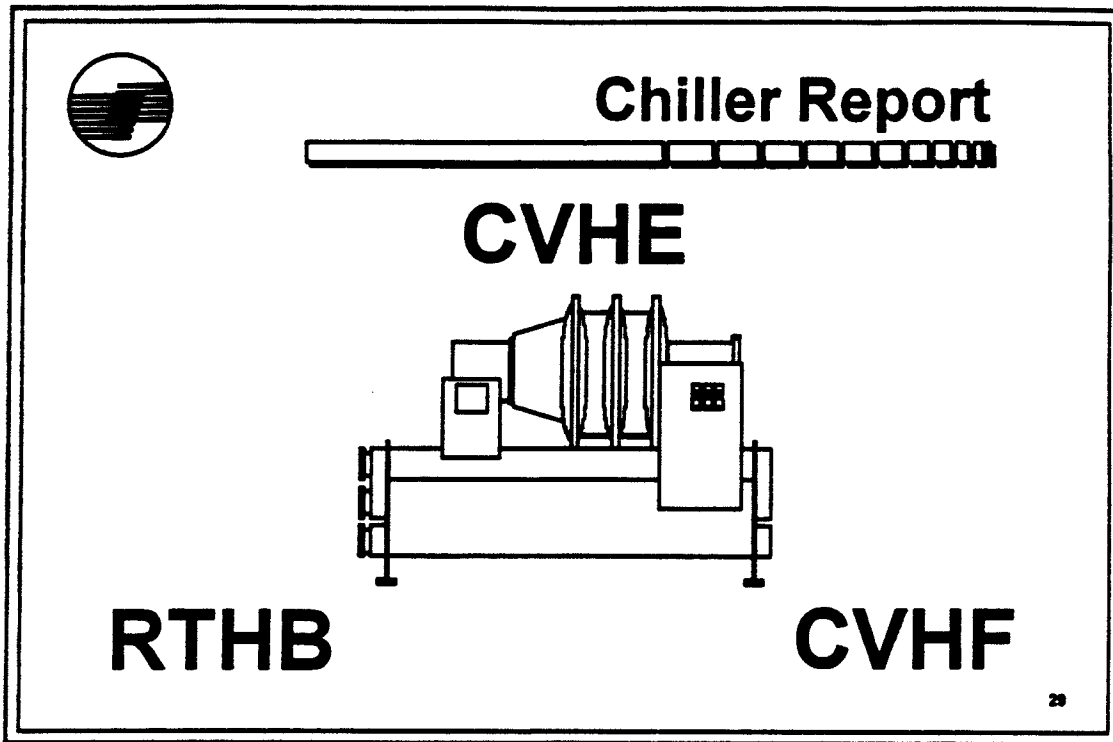

- The chiller report contains chiller operating data and setpoints such as current chiller operating mode and status, water temperatures and operating setpoints.
- Note: Setpoints cannot be changed when viewed from within a report.

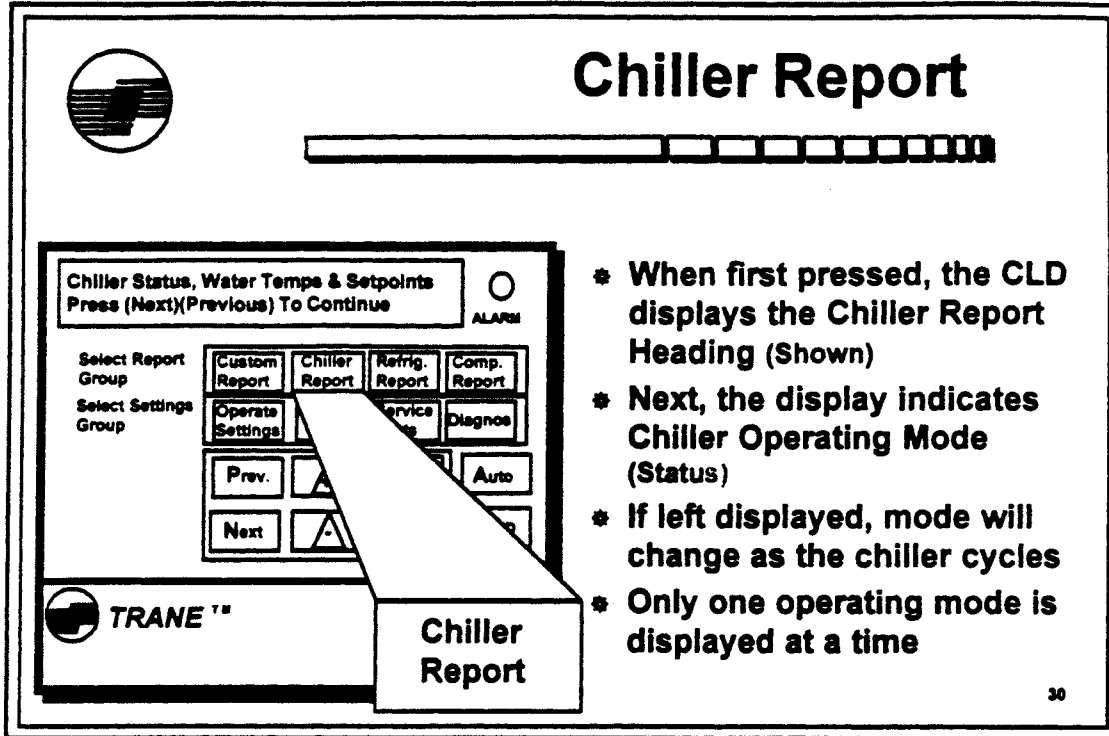

•The operator can view the chiller report by pressing the “Chiller Report” key. This will display the report heading:

**“Chiller Status, Water Temps & Setpoints -
Press (Next) (Previous) To Continue”**

•The next screen will display the chiller operating “Mode” on one or both lines. There are many operating modes available. Examples of operating modes are:

**“Auto-
Waiting For Evaporator Water Flow”**
- OR -
**“Unit Is Running-
Capacity Limited By High Condenser Pressure”**

•The operating mode message will indicate if the chiller is stopped, starting, running full load, running inhibited, locked out on a diagnostic condition, in free cooling, watering for water flows, in hot gas bypass, ice making, shutting down, in extended unloading (RTHB), etc.

•Refer to the chiller Operation and Maintenance Manual for a complete list of possible operating mode messages.

•Continuing to press the Next key will scroll though the remaining chiller report items; system water temperatures and active chiller operating setpoints.

Chiller Report

Active Chilled Wtr. Setpnt. xxx.x F/C
Evap. Leaving Wtr. Temp: xxx.x F/C

Select Report Group: Custom Report, Chiller Report, Refrig. Report, Comp. Report
Select Settings Group: Operate Settings, Service Settings, Diagnose

Prev. Next

TRANE

Chiller Report

- * Active Chilled Water Setpoint / Evaporator Leaving Chilled Water Temperature
- * Active Ice Termination Setpoint / Evaporator Return Water Temperature
- * Active Hot Water Setpoint / Condenser Leaving Water Temperature

31

• Throughout this program, we will be explaining the points displayed on the CLD. Each screen that appears in a report or a settings group is most often displayed on two lines, and will be presented on our slides as:

“Line 1 of display screen / Line 2 of display screen”

IMPORTANT

Items presented as *yellow* text are standard UCP2 features.

Items presented as *aqua* text are options available with UCP2.

These items will not be displayed at all if they have not been ordered and enabled in the settings menus at the factory.

• If the chiller has one or both of the options (aqua) shown on this screen, only one of these items are displayed, depending on chiller operating mode.

• If the chiller is in “ice-making” or “ice-making complete” mode, then the “Active Ice Termination Setpoint / Evaporator Return Water Temperature” display will appear instead of “Active Chilled Water Setpoint / Evap. Leaving Water Temp.”

• If the chiller is in “Hot Water Control” mode, “Active Hot Water Setpoint / Condenser Entering Water Temperature is displayed instead of “Active Chilled Water Setpoint / Evaporator. Leaving Water Temp.”



Chiller Report

(Continued)

Active Chilled Wtr. Setpnt: XXX.X F/C

Front Panel CWS: XXX.X F/C

ALARM

Select Report Group

Custom Report	Chiller Report	Refrig. Report	Comp. Report
Operate Settings	Service	Diagnose	

- * **Active CW Setpoint:**
Can change due to dynamic control such as Chilled Water Reset
- * **Active Ice Termination SP**
- * **Possible Setting Sources are:**
 - Front Panel
 - Tracer
 - External Source (Vendor System)
 - Ice Building
- * **Emergency Control**
Defaults To FRONT PANEL control



TRANE™

Chiller Report

32

•At this point, the screen will display one of two items, depending upon current chiller operating mode:

•The active chilled water setpoint is displayed on the first line, the setting source and the setting source setpoint on the second line;

or,

The active ice termination setpoint is displayed on the first line, the setting source and the setting source setpoint on the second line.

•The “active” setpoint is the one being used by the chiller at any given time. The setting source indicates the active CWS origin. Possible setting sources for *all setpoints in this program are* Front Panel, Tracer, Ice Building or External. Typically, the active CWS will be the same as the setting source setpoint unless something in the control system is modifying the CWS such as setpoint reset operation.

•Active ice termination data will only be displayed if the chiller is in “Ice-Making” or “Ice-Making Complete” mode. Also, the chiller must be equipped with the ice-building option and ice-making must be enabled from the Service Settings menu.

Chiller Report

(Continued)

- * Evaporator EWT / Evaporator LWT
- * Condenser EWT / Condenser LWT
- * Active Current Limit Setpoint
- * Active Current Limit Setpoint / Setting Source & Setpoint (Can change due to application)
- * Evaporator Water Flow / Condenser Water Flow (ctv)
- * Chiller Tons (Evaporator Only)

33

•EWT = Entering water temperature.

•LWT = Leaving water temperature.

•Evaporator and condenser temperature readings provide Delta-T's.
If sensor is open or shorted, screen will display dashes.

•Active current limit setpoint given in percent of full load amps.

•Again, possible setting sources for *all setpoints in this program are:*

Front Panel
Tracer
Ice Building
External

•Differential water sensing option must be installed and enabled in order to display water flows and chiller tons.



Chiller Report

(Continued)

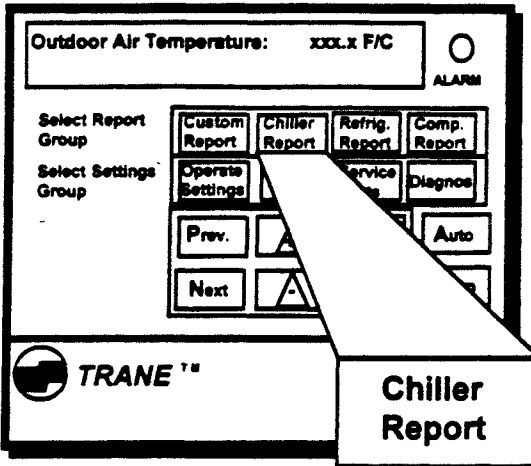

- * Outdoor Air Temperature (Reset Control)
- * Aux-Heat Recovery EWT / LWT (Ctv)(Preheat Domestic Hot Water)
- * Chilled Water Setpoint Source (Tracer, Front Panel, External) / Reset Condition (None; Outdoor Air Temp.; Return Water Temp.)

34

• If the outdoor temperature sensor is open or shorted and neither Outdoor Air Reset nor Ambient Lockout is enabled, the screen will display dashes instead of the outdoor air temperature. Otherwise, the screen will display the temperature received from the chiller module.

• The chilled water setpoint source can be set at the Tracer, the Local panel or an external Building Management Source. If the Tracer or an external source fails, the local panel responds.

• If the reset option is used, this tells you how it is controlled.



Chiller Report

(Continued)

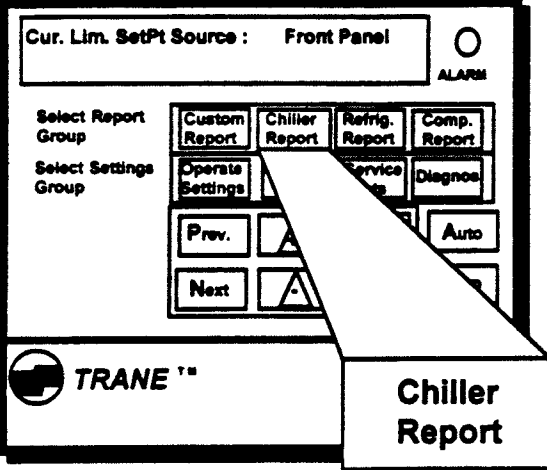

- ✱ **Current Limit Setpoint Source:** (Tracer, Front Panel, Ice Building, External Source)
- ✱ **Hot Water Setpoint Source (ctv)** (Front Panel, Tracer, External Source)
- ✱ **Ice Termination Setpoint Source** (Front Panel, Tracer)



TRANE™

Chiller Report

35

- Current Limit control is adjustable from 40 to 100 %. It can be adjusted at several locations.
- Hot Water Setpoint Source displayed only if Heat Pump Control is enabled and chiller is in “Hot Water Control” mode.
- Heat Pump Control is used in rare cases where the CenTraVac is used to provide heating instead of cooling as a primary mission.
- A remote thermostat could be used to control the guide vanes via the “guide vane remote-control” input. The operator would select a hot water temperature and the chiller would be operated to maintain the hot water setpoint. This type of application requires an endless source of heat such as a lake or well.
- Ice termination data will only be displayed if the chiller is equipped with the ice-building option and ice-making has been enabled from the Service Settings menu.

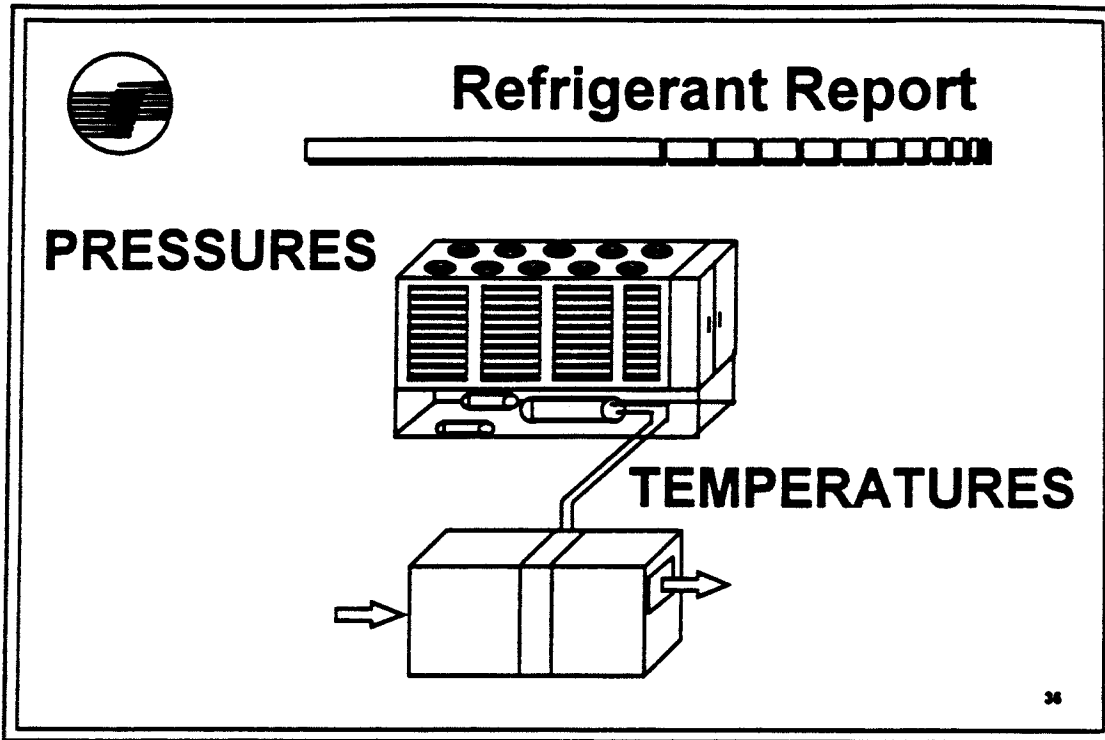

•The refrigerant report contains refrigerant-related information such as pressures, temperatures, purge operating data and equipment room refrigerant monitor log data.

•Reminder: Setpoints cannot be changed when viewed from within a report.

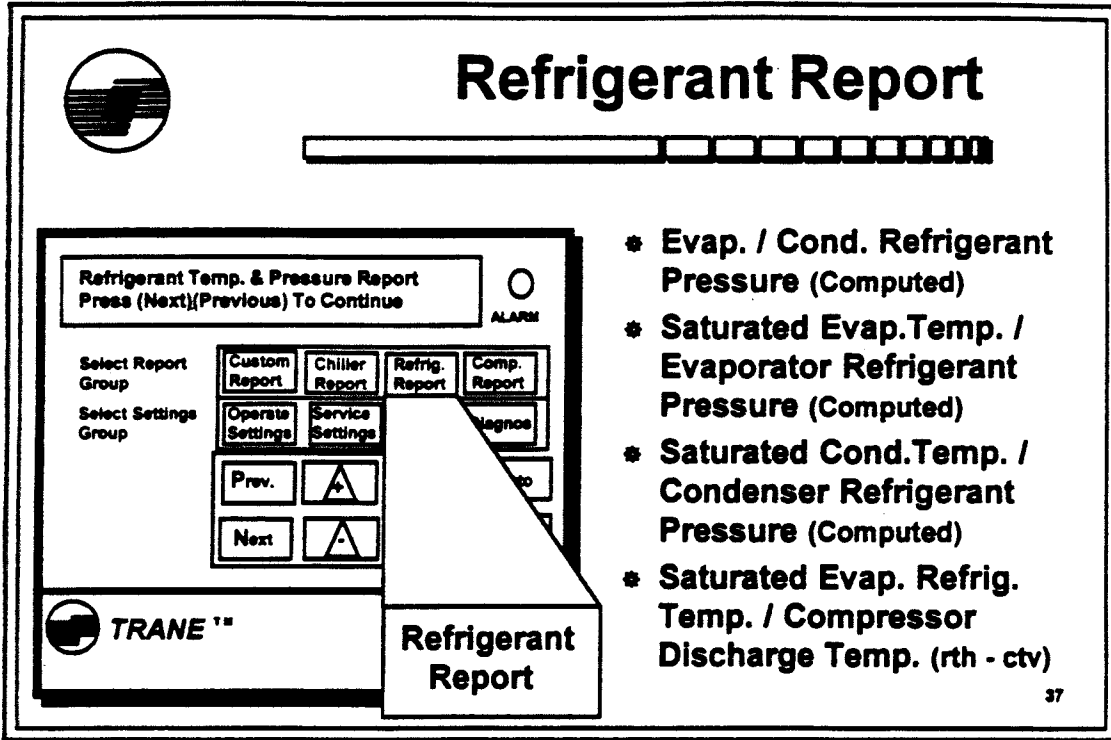

•The operator can view the refrigerant report by pressing the “Refrigerant Report” key. This will display the report heading:

**“Refrigerant Temp & Pressure Report-
Press (Next) (Previous) To Continue”**

•The next screen will display two report items, one on each line. The first screen is:

**“Evap Rfgt Pressure: XXX.X psig-
Cond Rfgt Pressure: XXX.X psig”**

•Compressor discharge temperature sensing is standard on RTHB units because electronic expansion valve (EXV) control is derived from a combination of discharge superheat and chilled water delta-T. However this feature is optional on centrifugals and will not be displayed unless enabled. This is used on ctvs that have hot gas bypass.

•Continuing to press the Next key will scroll though the remaining refrigerant report items.



Refrigerant Report

(Continued)

Refrigerant Temp. & Pressure Report
Press (Next)(Previous) To Continue

ALARM

Select Report Group

Select Settings Group

Custom Report	Chiller Report	Refrig. Report	Comp. Report
Operate Settings	Service Settings	Diagnose	to
Prev.	▲	▼	Next

RTH Units Only

- ✱ Compressor Disch. Temp. / Discharge Superheat
- ✱ Disch. Superheat Control Point / Discharge Superheat
- ✱ Expansion Valve Position (% Open) / Expansion Valve Position (Steps Open)



TRANE™

Refrigerant Report

•If you have the RTH series units, R-22 refrigerant can be measured by looking at superheat and subcooling. Centravac units do not make enough to be measured.

•Superheat is measured at the compressor discharge.

Page 38



Refrigerant Report

(Continued)



Purge System

39

- The Purge Unit has been redesigned many times. The new purge along with the "0" Emissions Tank is quality plus.
- The new purge has an exterior in-line filter that can be replaced in short order with little work.
- People in the past wanted many reports about how the purge operated. Today those reports are available.

Refrigerant Report

(Continued)

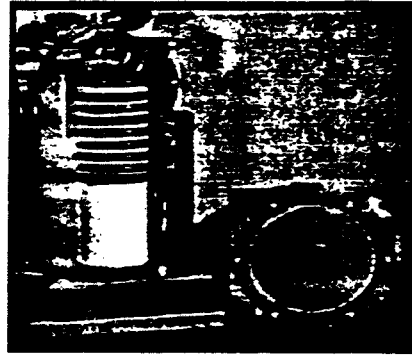
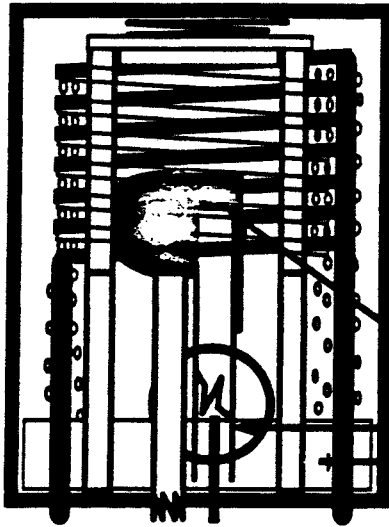

Refrigerant Vapor In
Refrigerant Liquid Out
Refrigerant Vapor Filter Drier Cores

40

•The purge unit allows refrigerant gas, air, Moisture into the purge tank. The evaporator in the purge tank condenses refrigerant and water. The refrigerant returns to the condenser, the water is trapped and any air is released to the "0" Emissions Drum.

•The Filter in the old system is found in the purge tank. This takes more time to service.

Refrigerant Report

(Continued)

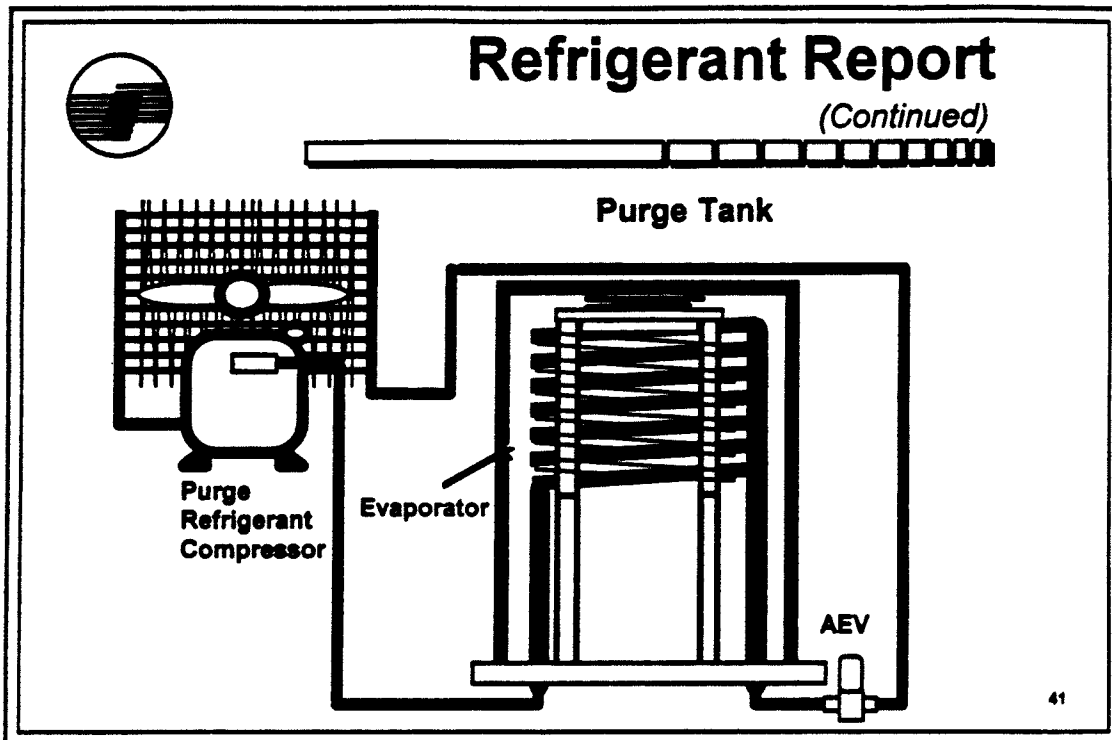

•A self contained refrigerant system provides cooling to condense refrigerant in the purge tank. This system operates using R-134a refrigerant. R-12 Refrigerant was used in the past.

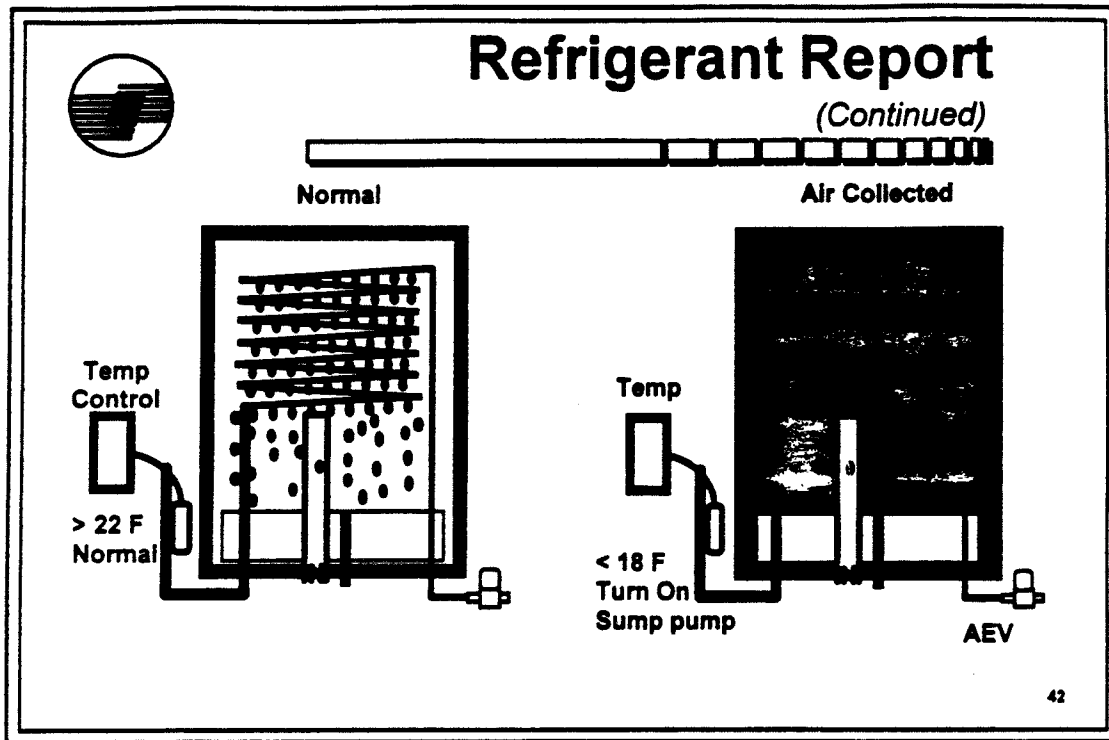

•In the clean system, the total area of the tank is used to condense refrigerant. The evaporator superheat temperature is stable in the 22 Degree range. When air is collected in the purge tank, the unit is not very efficient and the superheat temperature is less because less condensing surface is available. The refrigerant is not used and the temperature of the refrigerant gas goes down.

Refrigerant Report

(Continued)

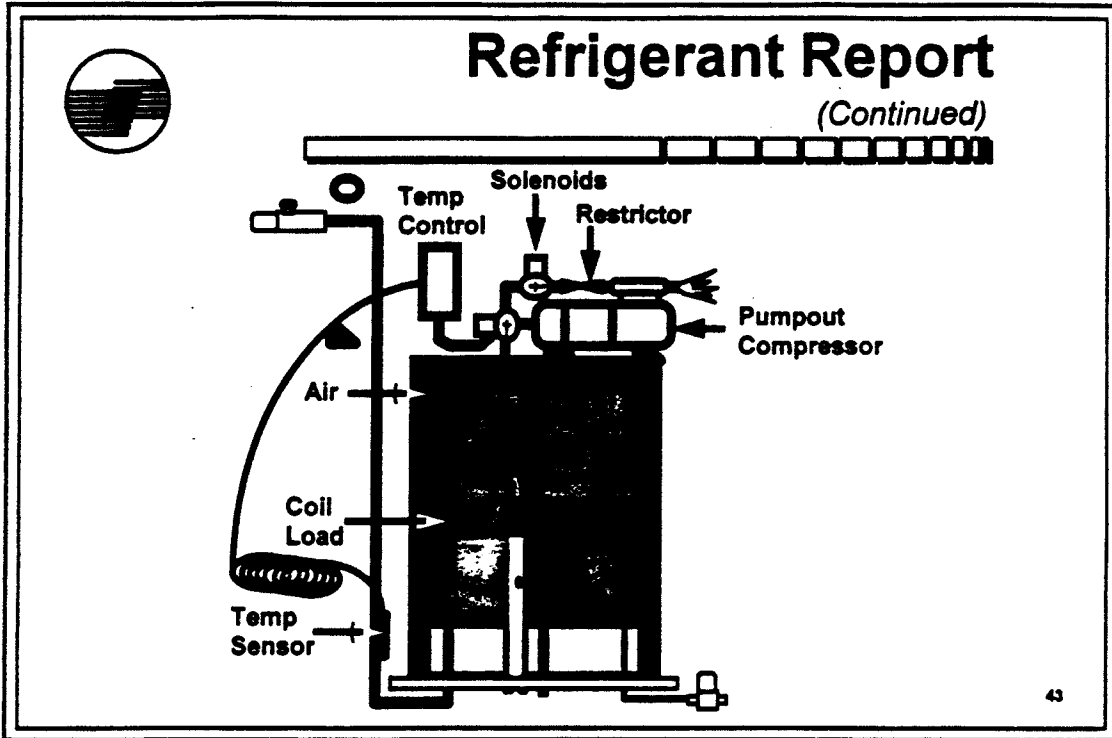

•As the temperature of the purge tank is reduced, the sensor tells the temperature control to energize the pump out compressor and the purge solenoids to open. As air escapes, the tank temperature will rise. When 22 degrees is reached the solenoid and compressor will close and stop. This completes the cycle.

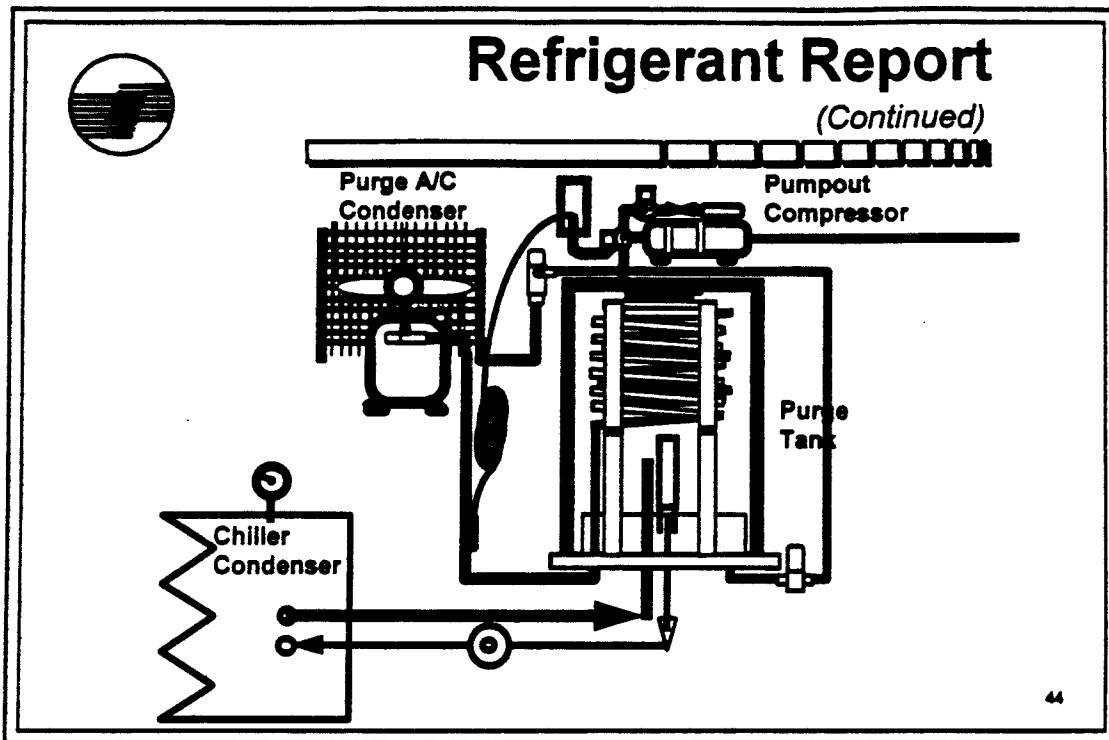

- This is the complete system. Notice where the purge gasses come from and where they go.

- Remember, two circuits exist:
 - A. The Centravac Refrigerant Circuit
 - B. The Purge Refrigerant Circuit



Refrigerant Report

(Continued)



Purge Operating Modes (Stop, On, Auto, Adaptive)

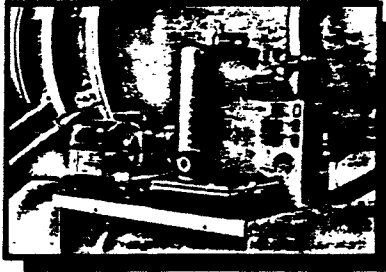

1. Stop = Purge condensing unit will not run
2. On = Purge condensing unit runs continuously whether the chiller runs or not and relieves air when needed.
3. Auto = If the chiller is operating, the purge will operate when needed as controlled by the pressure switch or timer (default mode)
4. Adaptive = Purge monitors it's activity over 30 days, averaging run and relief time and operates in response to this record.

RTH Units require no purge

45

•The purge system can be found in 1 of 4 control positions.

•A new term "Adaptive " is being used. This is an operating mode that allows the purge to operate by the demand of time which comes from several sources ie: The Month, Average Run Time and Relief Time.

•If you need more or less purge time, you automatically get it.



Refrigerant Report

(Continued)



* Purge Status

(Idle, Running, Pumpout, Service Pumpout,
Running Inhibited, Pumpout Max. Rate Disabled)

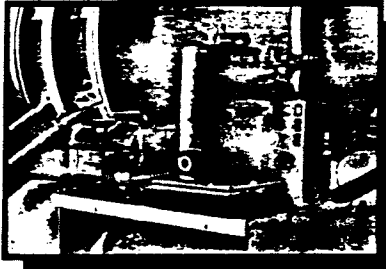

1. Idle = Purge condensing unit off
2. Running = Purge condensing unit on
3. Pumpout = Purge compressor on and pumpout compressor on by purge compressor suction temp. switch.
4. Service Pumpout = Manual pumpout initiated by operator at control panel switch.
5. Running inhibited = Pumpout inhibited by low liquid temperature.
(Makes Ice Cubes)
6. Pumpout Max. Rate Disabled = Max. Pumpout Rate Alarm Disabled

46

•As the purge unit advanced in quality and technology you asked for a way to log what has happened in the past. You now have that capability.

•The purge now has status conditions that will show on the purge reports. The terms must be understood.



Refrigerant Report

(Continued)



- * **Purge Alarm Message**
(Go to Diagnostics for message)
- * **Purge Suction Temp.** (Compressor Circuit, Starts and Stops the sump Pumpout Compressor @ 18 F & 22 F)
/ **Purge Liquid Temp.** (Chiller Circuit Freeze Protection, Purge evaporator chiller refrigerant output saturated temp. measured at the filter drier)
- * **Purge pumpout rate (24 Hrs.) / Purge maximum pumpout rate (Set by operator)**

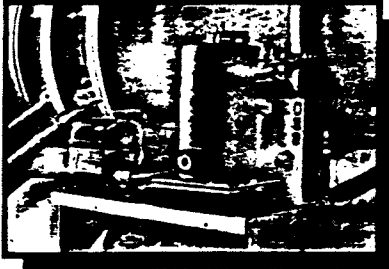

47

•When viewing alarm messages, you must go to system diagnostics and page through until you find the correct diagnostic call out.

•The R-134a refrigerant system operates at 0 F. Superheat at the metering valve and 22 F. Superheat at the suction line. If the super heat lowers to a point below 18 F. the purge exhaust compressor will start and exhaust trapped air located in the purge sump to the atmosphere or to a "0" Emission Tank. Purge suction temperature is the trigger to start the purge exhaust compressor.

•If the purge sump temperature gets too low, any moisture trapped in the tank will freeze. Measuring the chiller saturated liquid temperature at the liquid filter in the purge system provides a control point that will stop the purge system if the liquid temperature lowers to 32 F. Factory default is 40 F.

•Purge pumpout rate provides a reading showing how much pump out time has been used in the past 24 hours.

•Max. rate is your cutout point to provide an alarm for excess pumpout time. This is adjustable by you.



Refrigerant Report

(Continued)

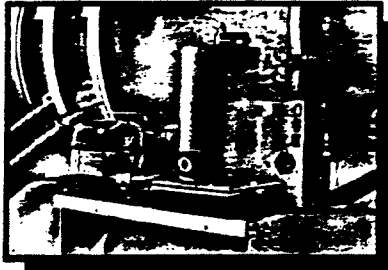

- * **Purge Total Pumpout Time**
(Exhaust compressor) / Purge Total Run Time (Purge refrigeration system from time of installation)
- * **Purge Adaptive Cycle Time - Chiller On** (Purge off cycle time) / Time to Purge Remaining
(Purge off-time remaining before purge is allowed to operate)
- * **Purge Adaptive Cycle Time - Chiller Off** (Extended Purge off cycle time) / Time To Purge Remaining
(Purge off-time remaining before purge is allowed to operate)

48

- You must keep in mind that an R-134a system, an R-123 system, and an exhaust system exists on a purge system.
- Purge total pumpout time refers to the Exhaust System.
- Purge total run time refers to the R-134a System.
- Purge Adaptive Cycle time - Chiller On = The purge off cycle time computed by the adaptive mode based on cumulative pumpout history for chiller on operating periods. After 60 min. of run time at start up without pumpout occurring. Example:
 - Average pumpout time w/chiller on = 1 min. on to 4 hours off
 - = 1 to 3 min. on to 3 hours off
 - = 3 to 5 min. on to 2 hours off
 - = 5 to 8 min. on to 1 hours off
 - = >8 min. on to no off cycle
- Purge Adaptive Cycle Time - Chiller Off (Extended off time) =
The purge off cycle time computed by the adaptive mode based on cumulative pumpout history for chiller on and off operating periods. ie: Extended off time - Power remains on purge unit.
 - Average pumpout time w/chiller off = <1 min on to 14 days off
 - = 1 to 2 min. on to 10 days off
 - = 2 to 3 min. on to 6 days off
 - = 3 to 4 min. on to 4 days off
 - = 4 to 5 min. on to 3 days off



Refrigerant Report

(Continued)

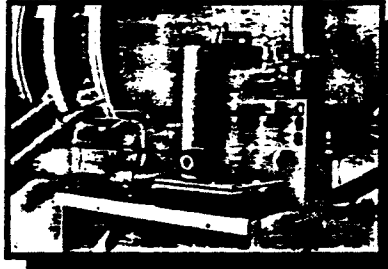

- * **Purge Service Log (Can be reset in Service Settings) / Purge Pumpout Time (Accumulated relief time - Present log)**
- * **Purge Service Log / Time Since Last Reset (Days since last log reset)**
- * **30 Day Purge Pumpout Average (Minutes/day - Chiller off or on) / Chiller Average Run Time (Hrs/day)**

49

•This log can be reset from the Service Settings group in the Field Start up section.

•Purge pump out time - A cumulative log of purge pumpout time since this log was last reset. This output is provided to help the operator track desired service intervals which are dependent upon purge activity.

•Time since last reset - A cumulative calendar day log since this log was last reset. This output is provided to help the operator track desired service intervals which are dependent upon elapsed time.

•30 day Purge Pumpout Average - Average pumpout activity per 24 hour period over the last 30 days

•Chiller run average - This is a summation of chiller run time in hours divided by the number of days of available data. (Pumpout activity indicative of total chiller leak picture.)



Refrigerant Report

(Continued)

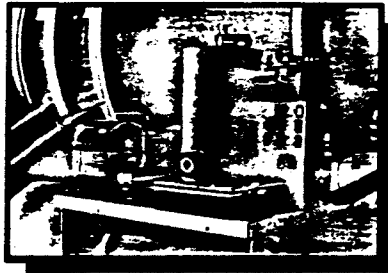

- * 30 Day Pumpout Average, Chiller Running (Minutes)
- * Last 5 Cycle Pumpout Average, Interval from shutdown to 3 hrs after shutdown (Minutes)
- * 30 Day Pumpout Average: Interval from 3 hrs after shutdown to next start (Minutes)

60

•30 day pumpout average, Chiller running - This summary includes all pumpout data for periods when the chiller is running. Large service pumpouts are not included if they occurred more than 7 days in the past. (Pumpout activity indicative of chiller running leaks.)

•Last 5 cycle - Data is available for the previous 30 calendar days for pumpout data during the first 3 hours following chiller shutdown. Large Service pumpouts are included. From this data, the average for the last 5 shutdown cycles is reported here.

(Pumpout activity indicative of chiller air storage during operation.)

•30 day pumpout average - This summary includes all pumpout data for extended chiller shutdowns (beyond the 3 hour period covered above). Large service pumpouts are not included if they occurred more than 7 days in the past. (Indicative of seal, O - Ring, ect leakage during chiller off periods.)



Refrigerant Report

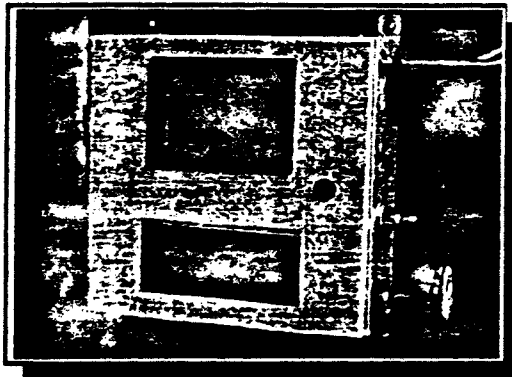

• **Refrigerant Monitor**
(Parts per Million)

• **ASHRAE 34**

- Equipment room
refrigerant vapor level
reading

- Alarm device

- Starts ventilation fans

• **Evap / Cond Approach**
Temp

61

•The refrigerant monitor circulates room air through a sensing cell to provide a continuous indication of refrigerant vapor concentration.

•The monitor utilizes infra-red photo-acoustic sensing technology allowing accurate measurement with minimum interference from other chemicals in the vicinity.

•The instrument is compound-specific and factory calibrated for the refrigerant of interest.

•It is capable of measuring down to 1 ppm to a maximum of 1,000 ppm. Has 3 alarm levels and 1 unit self test trouble alarm.

•The monitor must:

1. Signal alarm lights or horns
2. Start emergency ventilation or signal a building management system

•Knowing the coil approach and being able to measure it is a major service tool. Check water flow first, then approach.

 **Compressor Report**

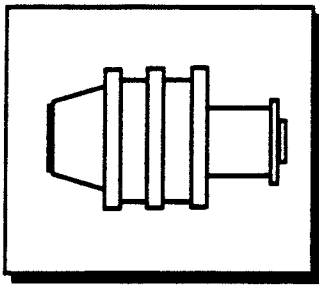
Bearings  **Temperature**

Oil Pressure **Windings**

52

•The compressor report is a very important service tool. These reports will save maintenance time and lower overall service expense.

Compressor Report

- * Differential Oil Pressure / Oil Tank Temperature (ctv)
- * Compressor Adjustable Speed Command (Hz / %; ctv)
- * Discharge Oil Pressure / Oil Tank Pressure (ctv)
- * Inlet Guide Vane Position (ctv)
- * Comp Ph Cur - % RLA
- * Comp Ph Cur- AMPS Per Ph
- * Compressor Phase Voltages
- * Compressor Power Factor and Watts (% - Kw; ctv)

53

•Net oil pressure is a confusing measurement. The ucp 2 now provides that computation for you. Evaporator pressure difference from oil discharge pressure = Differential oil pressure. This is measured with oil pressure transducers.

•Oil (System operating) Temperature can be 120 F. Oil (System stopped) temperature can be 160 F.

• Speed command used with variable speed drive.

•Discharge oil and oil tank pressure is = to Net Oil Pressure (see above).

•Vane position displayed in % open and degrees.

•Compressor Phase Current in %RLA for all 3 phases.

•Compressor Phase Current in amps for all 3 phases.



Compressor Report

(Continued)



- * Compressor Winding Temperatures W1,W2,W3
- * Compressor Starts and Running Time
- * Bearing Temperatures #1 and # 2 (ctv)
- * Solid State Starter Heat Sink Temperature
- * Hot Gas Bypass Time (ctv)



75 Ohm 1/2 Watt at 75 Degrees F.

54

•Compressor Winding temperatures are available via thermisters. If a thermister fails, it can be jumped using a 75 Ohm Wire Wound 1/2 Watt resistor. If more than 1 thermister fails, do not jump them. Find out what the problem is and repair it.

•Compressor starts since the system was new.

•Compressor run time since new, Hours, Minutes and Seconds.

•Bearing temperatures are optional.

•Solid State Starter heat sink temperature is optional

•Hot Gas Bypass Time is optional

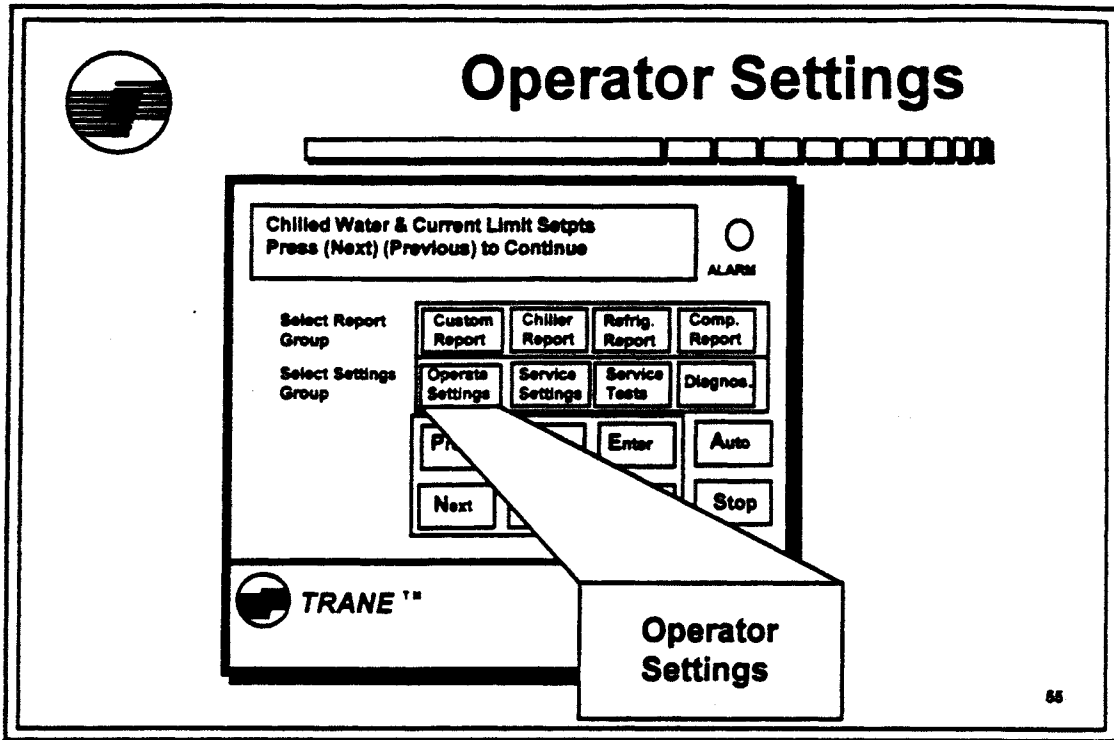

•Operator Settings contains adjustable points that an operator can access without fear of destroying the unit. As we proceed from this section on, you will see that passwords help protect the more dangerous entry points.

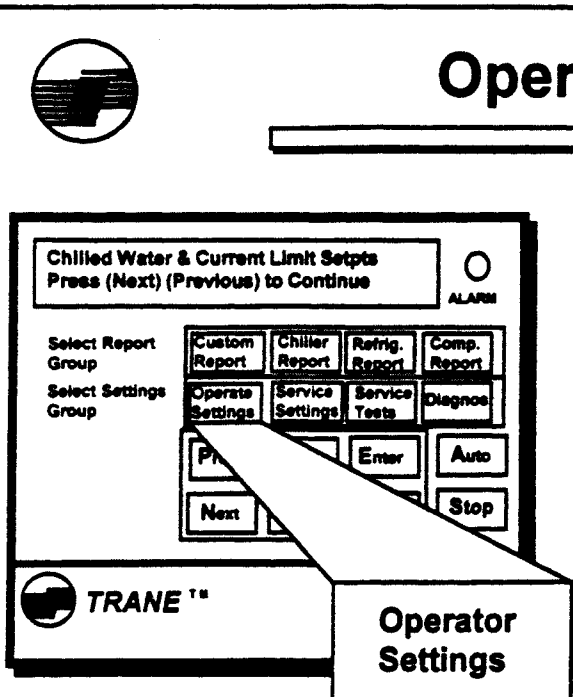

The diagram shows a control panel interface for a Trane system. At the top left is a circular logo. The main title is "Operator Settings". Below the title is a horizontal bar with several rectangular segments. The central display area shows a menu with the following text: "Chilled Water & Current Limit Setpts", "Press (Next) (Previous) to Continue", and "ALARM". Below this are two sections: "Select Report Group" with buttons for "Custom Report", "Chiller Report", "Refrig. Report", and "Comp. Report"; and "Select Settings Group" with buttons for "Operate Settings", "Service Settings", "Service Tests", and "Diagnos". At the bottom of the display are buttons for "Ph", "Enter", "Auto", "Next", and "Stop". A callout box labeled "Operator Settings" points to the "Operate Settings" button. The Trane logo is visible at the bottom left of the display area.

- * Operator Settings
- * Service Settings
- * Service Tests
- * Diagnostics
- * Passwords MAY BE Required
- * FOR CHANGING LOCAL SETTINGS ONLY

56

•The next 4 buttons control the chilling equipment. Each of the buttons have a password that has to be accessed before changes can be made.



Operator Settings

Settings in this Menu are : Unlocked
Press (Enter) to lock

ALARM

Select Report Group	Custom Report	Chiller Report	Refrig. Report	Comp. Report
Select Settings Group	Operate Settings	Service Settings	Service Tests	Diagnose
	Print	Enter	Auto	
	Next		Stop	

- * If unlocked, settings can be viewed and changed
- * If locked, settings can be viewed only
- * To unlock menu, press (- + - + - + Enter)
- * If screen is missing, password protection is disabled. You can enable it from the Service Setting Group

TRANE™

Operator Settings

57

•Follow the above mentioned instructions.

Page 57



Operator Settings



* Purge Operating Mode

Purge Operating Mode : Auto
Press (+) (-) to change settings

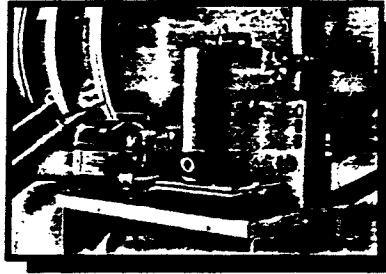

- Off - Condensing unit will not run
- On - condensing unit runs constantly, Pumps out when needed
- Auto - Purge runs when needed if the chiller runs constantly (Default)
- Adaptive - Purge operates in response to 30 day data

58

•The purge operating mode can be in 1 of 4 positions. Auto is the position the purge unit should stay in . Adaptive means that the purge will respond to the computer output based on the past operational average.



Operator Settings



Current Time/Date : 07:52 am Jan 1, 1994
(Enter) to change : (Next) to Continue

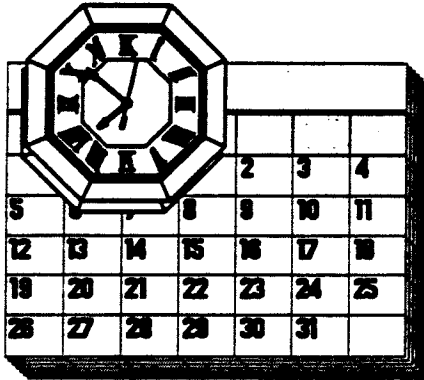

* Current Time/Date

- + - Time Enter
- + - Minute Enter
- + - Month Enter
- + - Day Enter
- + - Year enter

- * "Chiller Clock Updating" Screen Appears After Every "Enter"

•The clock is the place to enter the correct Time, Hour, Minute, Month, Day and Year.

•When changes are made, "Enter" must be entered after each change.



Operator Settings

Front Panel Chilled Wtr.Setpt: xxx.x F/C
 Limited by cutout Setpt, (+) to Change

Front Panel Current Limit Setpt: xx-%
 Bottom of Range, Press (+) to change

Front Panel Hot Wtr Setpt: xxx.x F/C
 Press (+) (-) to Change

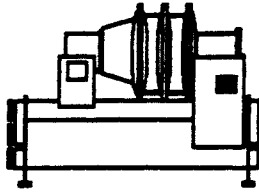

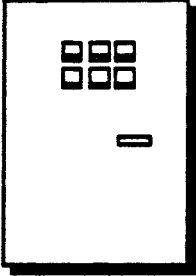

- * **Chilled Water Setpoint***
(Default 44 F) (1.7 F. LWT & 6 F. Refrig. Temp. Minimum Differential to Setpoint)
- * **Current Limit Setpoint***
- * **Hot Water Setpoint***
(Default 130 F)
(ctv only)

- This is where you set the value of the chilled water setpoint. The factory default is 44 deg F., but can be set from 0 to 65 deg. F.

- If you try to set a temperature above or below the range, a second line message will appear:

1. Top of range, Press - to advance
2. Bottom of range, Press + to Continue

- When the Front Panel Chilled water Setpoint is within 1.7 deg F. of the Leaving Water Temperature Cutout setpoint, or within 6 deg. F. of the Low Refrigerant Temperature Cutout Setpoint, the second line of the display will read:

"Limited by Cutout Setpoint, Press + to Continue.

- Current Limit Setpoint = Adjustable from 40 to 100 %

- In the past to soft load a system, a minimal load like 50 % was set up on current limit and as the building cooled down the limit was manually raised to 100 % as the building cooled down. Today, it is automatic through a algorithm.



Operator Settings

(Continued)

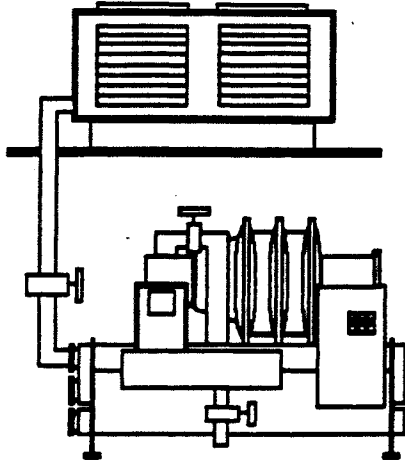

Free Cooling: OFF
Press (+) (-) to Change

- * **Free Cooling Enable**
(On / Off; ctv only)
 - Suction / Discharge Bypass Valve
 - Refrigerant Flooding Valve
 - Extra Refrigerant Storage
 - Tower Water Temperature Valve

61

•Free cooling is a method to obtain 50 to 70 % cooling without the compressor running during specific times of the year. If you have a hot inside space with a cold outside air condition, flood the evaporator with extra refrigerant, turn the inside and outside water pumps on and cool the space. As the differential becomes larger the efficiency gets better.

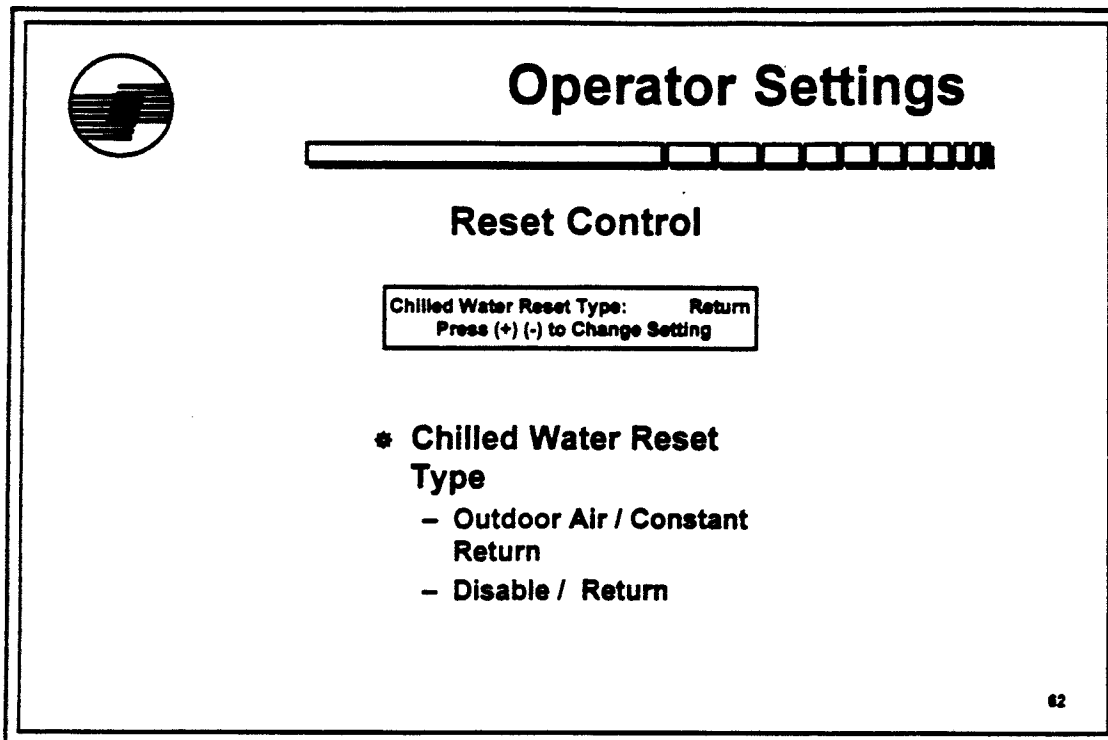

- Chilled Water Reset is a way to save chiller running costs without destroying comfort cooling.
- Reset allows discharge water temperature to raise as the building load decreases. The amount is adjustable.
- The reset start point is adjustable.
- The speed of reset is adjustable.
- If your chiller drives a process and not comfort cooling, reset is not wanted.



Operator Settings



Old Reset Control

Return Water Temperature Sensing

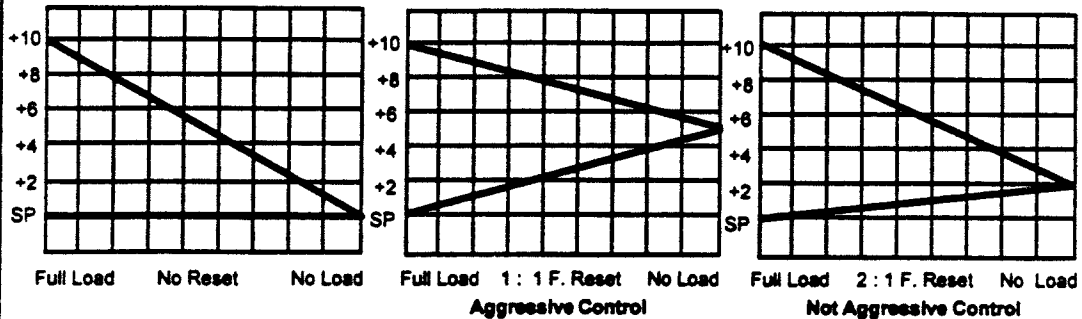

63

- No reset provides constant discharge temperature regardless of the return water temperature.
- One to one reset allows the discharge water temperature to raise at the same rate as the return water temperature drops. This is considered aggressive.
- Two to one reset allows the discharge water temperature to raise at a lesser rate as the return water temperature drops. This is considered less aggressive.



Operator Settings



Reset Ratio = Aggressiveness
Start Reset = Top of range from setpoint
Maximum Reset = Max.amount of reset aggressiveness (5 degrees)

	Reset Type	Range	Increment	Default
Reset Ratio	Return	10 - 120 %	1.0 %	50 %
	Outdoor	80 - (-80 %)	1.0 %	10 %
Start Reset Setpt.	Return	4-30 F	.1 F	10 F
	Outdoor	50 - 130 F	.1 F	90 F
Max. Reset Setpt	Return	0 - 20 F	.1 F	5 F
	Outdoor	0 - 20 F	.1 F	5 F

64

- The maximum reset available is 0 to 20 degrees.
- Start reset (Outside air Measuring) = Will work between 50 to 130 degrees of outside temperature.
- Start reset (Return Water Measuring) = Will work between 4 to 30 degrees above leaving chilled water setpoint.
- Reset Ratio = Speed of change ie: .5 to 1, 1 to 1, 1.5 to 1, 2 to 1
Instead of the old style of dip switches, we now have percentages. ie 10 to 130%
- The Standard rate of change is 1 degree F. per every 5 minutes.



Operator Settings



Outside Air Reset

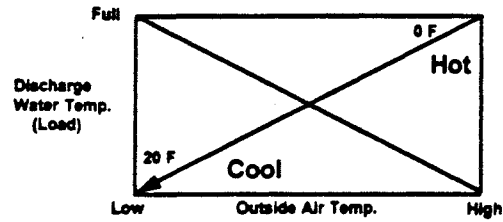

65

- Outside air reset is adjusted as the outside air temperature drops.



Operator Settings



Reset Calculations

Formula

Reset = Start Reset - Outdoor Air Temp.
X Reset Ratio + Chilled Water setpoint

$$90 - 70 \times 80\% = 16 \text{ F. Reset} + 45 = 61$$

**IF MAXIMUM RESET IS SET AT
5 F., THE FINAL TEMPERATURE
WILL BE 50 F.**

66

•Reset today is accomplished by working out a formula. There are no dip switches to push. Follow the formula.



Operator Settings

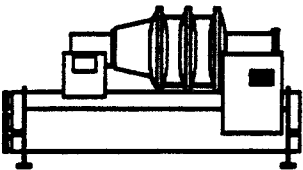
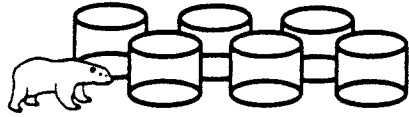

Ice Building D/E
 Press (+) (-) To Change Setting

- * **Ice Building Enable**
 - Enable Disable, ROM Default,
- * **Front Panel Ice Termination Setpoint**
 - 20 to 32 Degrees F, Factory ROM Default 27 F
- * **Ice Making To Normal Cooling Transition Timer**
 - 0 to 10 Minutes, Factory ROM Default 5 Minutes
- * **Ice Termination Setpoint Source**
 - *** (Out Of Sequence)
 - Front Panel, Factory ROM Default 67

•Ice Building is an option. If it is not used these callouts will not be seen.

•Ice Storage is an up and coming cooling method. Power companies offer large savings for those who install and use this type of system.

•Ice is made in the evening and used during the day.

•Cooling towers are critical in design when trying to make ice. On a humid evening, cooling towers become less effective and ice may not be made.



Operator Settings



**Chilled Water Setpoint Source
(Source)**

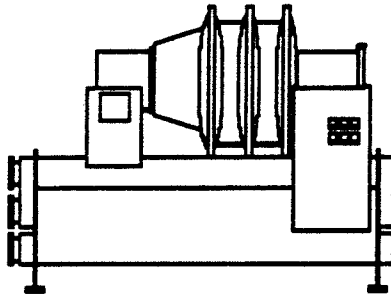

- * **Chilled Water Setpoint Source**
 - Front Panel, Factory ROM Default
 - External Source
- * **Current Limit Setpoint Source**
 - Front Panel, Factory ROM Default
 - External Source
- * **Setpoint Source Override**
 - None - Factory ROM Default,
 - Use Front Panel Setpoints

68

•All the above mentioned setpoint sources are set to the factory default. In the future, the source may be : External (BAS) source, Trane Tracer, Future 1, Future 2.

•Front panel is the normal source.

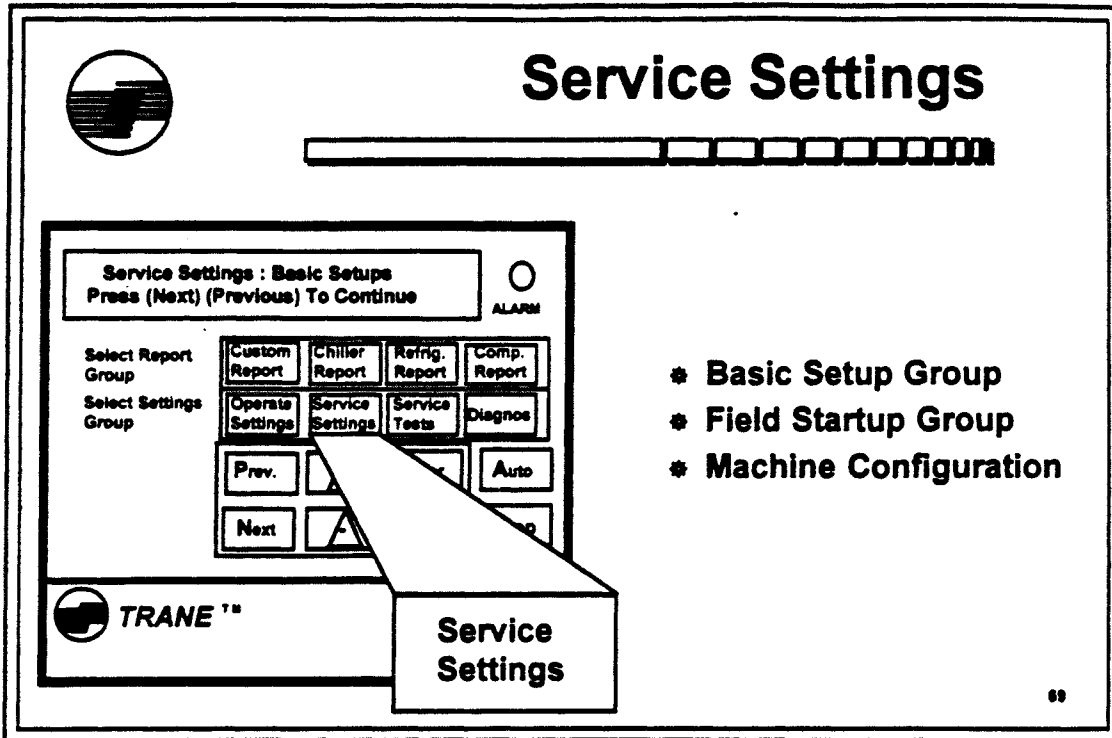

•Service Settings = Basic settings, Field Startup settings, Machine Configuration settings.

•The Basic Setup Group requires no password, but the rest do.

Service Settings

Settings In This Menu Are: (Status)
(Password Message)

ALARM

Select Report Group: Custom Report, Chiller Report, Refrig. Report, Comp. Report

Select Settings Group: Operate Settings, Service Settings, Service Tests, Diagnose

Prev. [Up Arrow] Enter Auto

Next [Up Arrow] Stop

TRANE™

Press

*** Passwords**

- Menu Settings Lockout
 - » (Enter) To Lock
- Menu Settings Unlock Password
 - » - + - + - + (Enter)
- Keypad / Display Lockout
 - » (Enter) To Lock
- Keypad / Display Password
 - » (Previous And Enter) At The Same Time
- Field Startup Group Password
 - » + + - - + + (Enter)
- Machine Configuration Group Password
 - » + - + - + - (Enter)

70

- Password required to enter service setting group
- Keypad can be lockout unless password is entered
- There are several languages available for display. The default is English
- Units are either English(default) or SI
- Either have 1 decimal place or none



Service Settings

(Basic Setups)

Language : ALARM

Press (+) (-) To Change Setting

Select Report Group	Custom Report	Chiller Report	Refrig. Report	Comp. Report
Select Settings Group	Operate Report	Service Settings	Service Tests	Diagnos
	Prev.		Enter	Auto
	Next		Cancel	Stop



TRANE™

Adaptive Control

- * **Language Settings**
 - English (Factory ROM Default)
 - » Francais (French)
 - » Deutch (German)
 - » Espanol (Spanish) Not Yet
 - » Nippon (Japanese)
 - » Italiano (Italian)
 - » Nederlands (Dutch)
- * **Display Units**
 - English (Factory ROM Default)
 - » SI
- * **Decimal Places**
 - XXX.X (Factory ROM Default)
 - » XXX

71

•The current UCP 2 can use English, French, or German. The rest are coming.

•When setting the decimal places, use the decimal place tenths. ie: 000.0 You will need it later when you enter Sea Level Pressure of 14.7 PSI.



Service Settings

(Basic Setups)

Display Menu Headings : D / E
 Press (+) (-) To Change Setting ALARM

Select Report Group

Custom Report	Chiller Report	Refrig. Report	Comp. Report
---------------	----------------	----------------	--------------

Select Settings Group

Operate Settings	Service Settings	Service Tests	Diagnose
------------------	------------------	---------------	----------

Prev.	▲	Enter	Auto
Next	▼	Cancel	Stop

*** Display Menu Headings**

- Factory ROM default is enable
- » When Disabled, All Headings in Each Menu Or Group Will Be Suppressed



TRANE™

Adaptive Control

72

•Group headings can be hidden. This can be very confusing and I would recommend that it stays in default which is enable.



Service Settings

(Basic Setups)



Differential To Start Setpnt: xxx.x F
Press (+) (-) To Change Setting

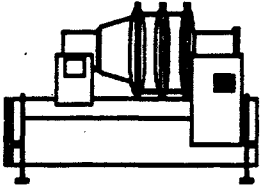

Setpoint = 45 Degrees

- **Differential To Start Setpoint**
– Range is 0 TO 10 F
- **Differential To Stop Setpoint**
• Range is 0 To 10 F

Warning: This setting will control with low water and refrigerant temperature limits.



73

•From leaving chilled water setpoint ie: 45 deg. F., a differential to start will provide a null zone so short cycling will not occur.

•The same thing occurs during the stop cycle.

•The adjustment range is from 1 to 10 degrees



Service Settings

(Basic Setups)



Evap. Pump Off Delay : xxx Min.
Press (+) (-) To Change Settings

Printer Setup
(Enter) To Change, Next To Continue

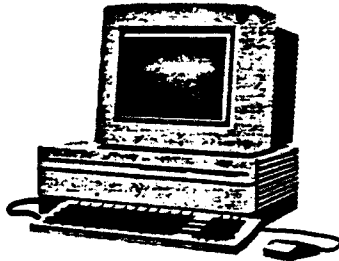

Okidata Microline 184
12 to 9 pin adapter

- Evaporator Water Pump Off Delay Time
 - Range Is 0 To 30 Minute-1Minute
- Printer Setups
 - Print on time interval-Enable
 - Print interval time-Hours
 - Print on Diagnostic-EnableOR
 - Number of Pre-Diag.-Reports
 - Pre-Diagnostic Reports-Interval

- Printer Baud Rate-300
- Printer Parity-None
- Printer Data Bits-8
- Printer Stop Bits-1
- Printer Hand Shaking-xon/xoff

74

•Residual cooling potential always exists in an evaporator chiller. When cooling limit is satisfied and the chiller turns off, let the pumps continue to run to distribute the remaining cooling potential.

•Printer setups are difficult and setup help can be confusing. Trane recommends and sponsors the Okidata printer, Model Microline 187. Follow your UCP2 defaults.



Service Settings

(Basic setups)



Press (Enter) to Clear The Restart
Inhibit Timer

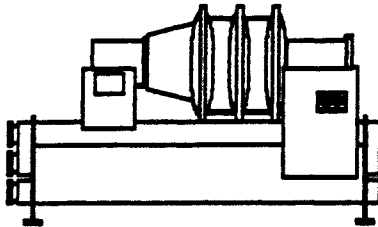

•Clear Restart Inhibit Time

-For Service Engineers Only
-Very Dangerous To The
Equipment

- »Eliminates The 30 Minute
Anti-Recycle Timer
- »A Second Screen Line
Appears For 2 Seconds,
Stating Restart Inhibit Timer
Has Been Cleared

75

- When clearing restart inhibit, the safety of your CTV can be in question. When using the UCP2 control, your CTV operates under an improved safety system.
- Motor temperature and time dictates the quantity of restarts you can have in a given period.
- If the motor temperature is below 165 F. the motor can restart after a 30 second delay.
- If a motor is above 165 F. a minimum of 15 minutes off time will be seen. This time can be increased to 60 minutes maximum.



Service Settings

(Field Startup Group)





Field Startup Group

- **Second Level Password Required (+ + - - + +)**
- **Keypad / Display Lockout (STOP AND AUTO DO NOT WORK IF LOCKED OUT)**
- **Menu Settings Password Feature (ALL SETTINGS CAN BE PASSWORD PROTECTED , BUT AUTO AND STOP WILL WORK)**

76

•The Field Startup Group is an area that is protected by a password. The password is a 6 digit code. You can press up to 20 characters, but only the last 6 count.

•Within this group you can lockout the keyboard. When this occurs, STOP and AUTO does not work. This means that the unit must be shutdown at the power switch or at the external switch jumper wire at the chiller module inside the control panel.

•When the menu settings password feature is used, all settings will be password protected, but AUTO and STOP will work. This feature will allow anyone to see, but not touch.



Service Settings

(Field Startup Group)



DOS / Windows System

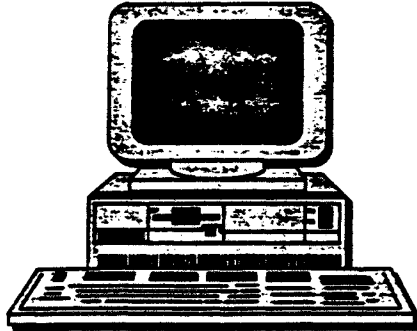

* ICS Address = Integrated Comfort System

- 6 - Ctv's to 1 Tracer, Summit, Chiller Plant Manager
- ICS "DIP switch" settings are in UCP2 software
- Point Type 42

77

•When a Trane Tracer is used, up to 6 Centravacs can be used. Each Centravac will have an address and can be called out separately.

•The Tracer point type -42

•Refer to your Tracer Programming Guide for additional information.



Service Settings

(Field Startup Group)



Tracer Address List

Name	Point Type	Address
Rooftop	09	1
VAV	25	35
CTV	42	65

* Tracer Address Assignment 01 - 127 (65 is the default) Warning Refer to Current Tracer Programming Guide

78

•Tracer can address 45 types of Trane equipment. Each type is given a code number. CTV's are given a point type 42.

•The default address is 65, but if no other addresses are used, a number 1 can be used.



Service Settings

(Field Startup Group)

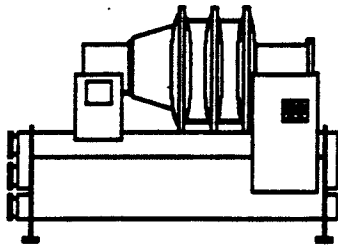

CTV

* Power Up Start Time Delay

- Multiple Chiller Delay Time
- Up to 600 seconds or 10 minute delay

* Design Temperature Delta "T"

- See Chiller Order Specs. (4 to 30 F)

79

•When several chillers are at the job, all chillers should not start at the same time. The power spike would be not acceptable. This time delay allows chillers to start with up to a 10 minute delay.

•Each chiller is designed to meet a system delta "T". This means temperature differential. Typically its 10 or 12 degrees. That is the best your chiller can do at rated water flow.



Service Settings

(Field Startup Group)

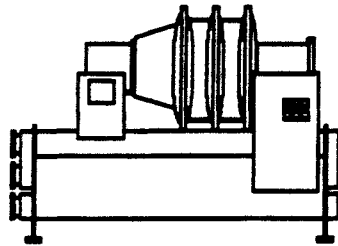

CTV

- * **Leaving (Low) Water Temperature Cutout Setpoint (-10 to 36 F)**
A 1.7 F. Null Zone exists between the Chilled Water Setpoint and the Low Water Temperature cutout setpoint :
Chilled Water Setpoint 37.0 F
Low Water Temp. Setpoint 35.3 F
Differential is 1.7 F
- * **Low Refrigerant Temperature Cutout Setpoint (-35 to 36 F)**
A 6 F. Null Zone exists between the Chilled Water Setpoint and the Low Refrigerant Temperature cutout setpoint.
Chilled Water Setpoint. 37 F
Low Refrigerant Temp. Setpoint 31 F
Differential is 6 F

80

•Leaving low water temperature cutout set point =This is the first stage freeze protection. The range is from -10 to 36 F. If you set the setpoint to 36 degrees, as the leaving chilled water drops to that point, the circuit will shutdown in an effort to prevent freeze up. Then a diagnostic will appear. There is a 1.7 F. null zone above the low temperature setpoint. If the low temperature setpoint is raised, the leaving chilled water setpoint will raise proportionately.

•Low refrigerant temperature cutout setpoint =This acts like the leaving low water temperature cutout setpoint. The only difference is that a 6 F. null zone is used instead of 1.7 F. and a larger range is used -35 to 36 F.



Freeze Protection



Old Classic And UCP 1 Control

Old 2 Stage Freeze Stat
10 F. Differential

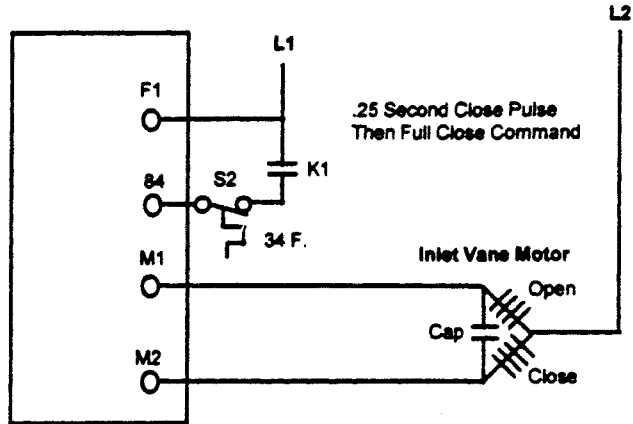
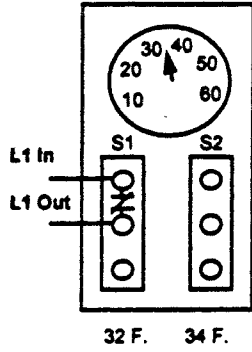



Freeze Protection



Evaporator Leaving Water Temperature Cutout

Minimum 1.7 F. Differential

45 F. Setpoint

Modulation of the vanes as Leaving Water Temperature Drops
"Normal Vane Control"

34 F. Cutout (MAR) In 30 Seconds

82



Freeze Protection



Evaporator Refrigerant Temperature Cutout

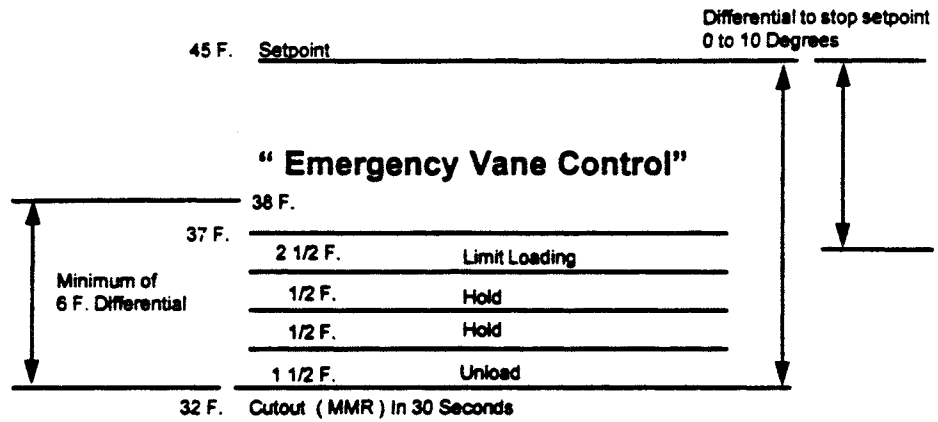

83



Freeze Protection



Evaporator Leaving Water Temperature Cutout

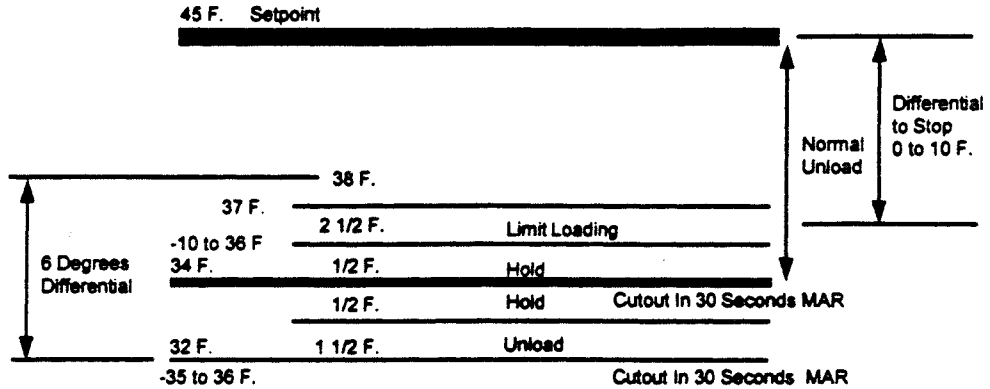

Evaporator Refrigerant Temperature Cutout



Service Settings

(Field Startup Group)

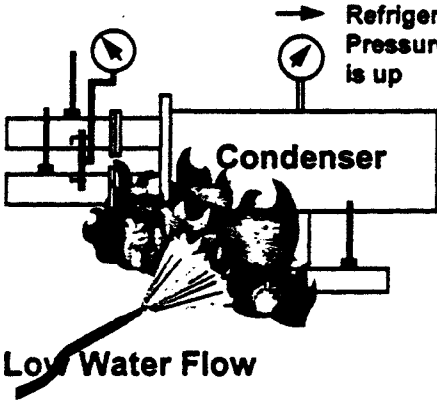

*** Condenser Limit Setpoint**

- High Pressure Cutout
- 80 to 120%
- Factory default is 93%
- 120% of 15 = 17 PSIG
- Used to prevent condenser rupture due to Heat and Pressure ie: 15 or 30 psig ASME Rated. See High Pressure Setting- See Config. Menu

Unload	Hold	Limit Load	Normal Loading
	100 %		1250 Steps / 5 Sec.
	15 Psig	14.4 Psig	13.5 Psig
	0 %	4 %	10 %

85

•This is a multistage control that acts to prevent chiller shutdown when the condenser refrigerant pressure approaches the cutout setpoint by reducing chiller capacity. Chiller capacity is reduced via the following steps, providing increasingly aggressive action as the trip point is approached:

1. Limit requests for capacity increases.
2. Prohibit requests for capacity increases.
3. Initiate stepped capacity reduction.
4. Initiate maximum capacity reduction.

•This function is based on condenser pressure or condenser refrigerant temperature. This depends on the sensing option used.

•The restart inhibit circuit is new and can be confusing. This circuit will be explained later. This is the maximum adjustment point for restart inhibit. The range is 30 to 60 minutes.

•Micro Purge is connected to the UCP 2. The Stand Alone Purge does not connect to the UCP 2.



Service Settings



*Maximum Restart Inhibit Setting

- 30 to 60 Minutes
- Factory default is 60 minutes
- Used to prevent motor overheating
- The BI Timer is based on the size of the Unit. The minimum time is 30 Seconds to 60 Minutes Depending on the Motor Heat (165 F.)
- Turn to page 63 of CVHE-M-7B and page 78

*Purge Control Type

- Micro Purge / Stand Alone Purge

••



Service Settings

(Field Startup Group)



- * **Service Log - Press Enter to reset**
 - Purge pumpout time 9999.9 min.
- * **Service Log - Press Enter to reset**
 - Time since last reset 9999.9 days
- * **Purge Maximum Pumpout Rate**
 - 1 to 100 min / 24 hrs.
 - Factory default is 20 min. / 24 hrs.
- * **Purge Disable Pumpout Alarm**
 - Is a service tool. Can be set up to 72 hours in 1 hr. increments
- * **Purge Low Liquid Temp. Inhibit**
 - Factory default is enable

87

•A cumulative log of purge pumpout time since this log was last reset. This output is provided to help the operator track desired service intervals which are dependent upon purge activity.

•A cumulative calendar day log since this log was last reset. This output is provided to help the operator track desired service intervals which are dependent upon elapsed time.

•The current maximum allowable pumpout rate established as user entered data. When the current pumpout rate exceeds the maximum, an alarm diagnostic is generated.

•The condensing unit is on, maximum pumpout rate alarm has been disabled by the operator.

•The condensing unit is on, pumpout inhibited by low condenser saturation temperature. This is to prevent freeze up in the evaporator.



Service Settings

(Field Startup Group)

Low Kinetic Energy Output

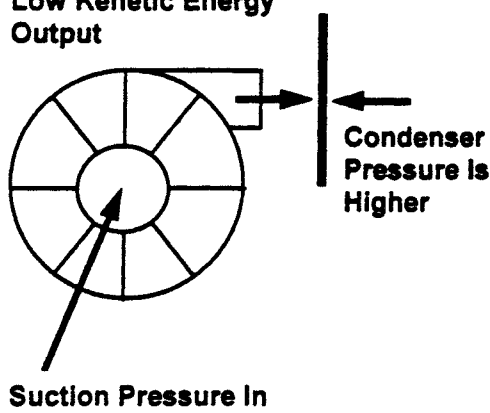

Suction Pressure In

*** Surge Protection**

- Looks at current fluctuations (5 in 60 seconds)
- Measures the current change intensity (RMS current change of 1.1/5 within .8 second)
- Measures the intensity for 15 minutes (Energizes the head relief request relay and shuts the machine down)
- Factory ROM default is enabled

88

•Operation of a chiller in surge can damage the chiller and reduce efficiency. The UCP 2 is able to detect the onset of surge and take actions to avoid operation in surge.

•Today's CVHE's offer the best chiller efficiency near the surge line. Chillers operating on 50 cycle and ice making are more susceptible to surge.

•When in surge, the chiller action is:

1. CVHE/F - Energize head relief request relay. (Close the inlet vanes and energize more cooling tower fans.)
2. After 15 minutes in surge, shut the unit down.



Service Settings

(Field Startup Group)

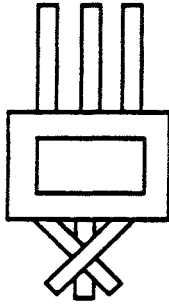

* Phase Reversal Protection

- Clockwise Rotation Only
- Will trip in 0.3 second after the compressor starts
- Factory ROM default is Enable

* Phase Unbalance Limit

- Derates Motor After 15%
- Ultimate Trip point 25% and will Raise To 30%
- Time to trip = 30 Sec.
- Individual sensing error 3% or 6% phase-to-phase
- Factory ROM default is Enable

* Momentary Power Loss

- 2 Cycles Trigger- 6 Cycles Stop
- Factory ROM default is Enable

»

•Motor rotation direction depends on how the phases of the incoming power are connected. The controls monitor the phasing of the incoming power and prevent the motor from starting in the wrong direction.

•Centrifugal chillers suffer a loss of capacity when operating in reverse rotation, but no permanent damage. Helical rotor and scroll compressors can be damaged by reverse rotation.

•L1 = Phase A, L2 = Phase B, L3 = Phase C

•Phase Unbalance Protection = Three phase currents supplied to the motor are monitored for unequal amperage draw. An imbalance in these currents causes the motor windings to heat up due to the unbalanced nature of the magnetizing currents.

•Motor overload is not considered to be a problem since each phase of the motor is being monitored for over current. Imbalance maybe caused by the incoming power or the motor.

•Power interruptions of less than 30 line cycles are defined as momentary power losses. The chiller will be shutdown.



Service Settings

(Field Startup Group)

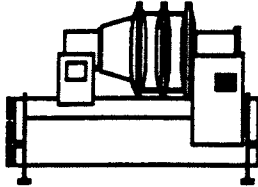

- * **Oil Temperature Setpoint**
 - 100 to 160 F
 - Factory ROM default is 143 F
- * **Low Oil Temperature Setpoint**
 - 80 to 140 F
 - Reset 5 F above setpoint
 - Factory setpoint is 95 F

90

•The UCP 2 shall provide an adjustable oil temperature setpoint adjustable from 100 to 160 F. The oil heater shall turn on 2.5 F. below the setpoint and 2.5 F. above the setpoint.

•The UCP 2 shall provide a fixed high oil temperature cutout of 180 F. If the oil temperature violates the cutout for more than 120 degree seconds an MMR diagnostic will occur.

•The CUP 2 shall provide an adjustable low oil temperature cutout stepping from 80 to 140 F. This diagnostic shall be active in all modes where the oil pump is not running. Once the pump is running, this feature is ignored. This is an MAR diagnostic.



Service Settings

(Field Startup Group)

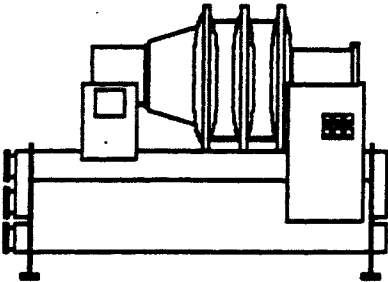

*** External Vane Control
For Base Loading**

- Honeywell
- Johnson
- Barber Colman
- Landas Gyr (Powers)
- Default is Disable
 - » 4 To 20 Ma.
 - » 0 To 10 Vdc
 - » Dip Switch Setting

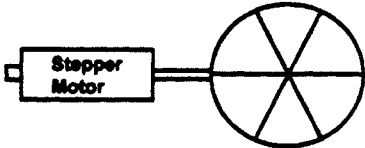

91

•This feature refers to an analog or binary input to the UCP 2 that can be used to position the inlet guide vanes. When this input is active, leaving water temperature control of inlet vanes is terminated and guide vanes move according to the input.

•Limit controls remain active and override the generic inputs.



Service Settings

(Field Startup Group)

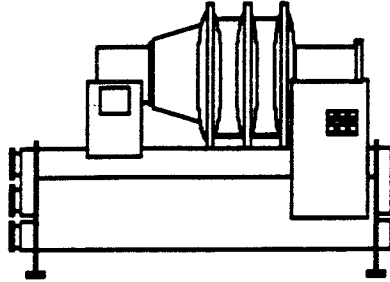

* Soft Loading Control Enable

- Used to prevent over-current fast start operation
- Avoids overshooting of setpoint
- Stabilizes startup of short loop water systems
- Factory default is Disable

* Soft Load Starting Current Limit Setpoint (CLS)

- Adjustable from 40 to 100%
- Adjustable in 1% increments
- Factory default is 100%

92

•Soft loading is used to bring the building loop temperature from its start value to setpoint in a controlled manner. Without soft loading, the chiller controls will load the chiller rapidly and use full chiller capacity to bring loop temperature to setpoint. Although the start temperature of the loop may have been high, the actual system load may be low. Thus, when the setpoint is met the chiller must unload quickly to the system load value. If it is not able to unload quickly enough, the supply water temperature will drop below setpoint and may even cause the chiller to cycle off.

•Soft loading prevents the chiller from going to full capacity during the cool down period (often done by imposing a current limit), or slows the rate of loading during the initial pull-down (Done by limiting the loading).

•Soft loading can be accomplished several ways:

1. Adjustable starting CLS: 40 to 100 % (Current Soft loading)
2. Adjustable CLS ramp rate: .5% / min. to 5% / min. (Current Soft Loading)
3. Adjustable LWT Max. ramp rate: .5F. / min. to 5F. / min. (Pull -down Softloading)



Service Settings

(Field Startup Group)

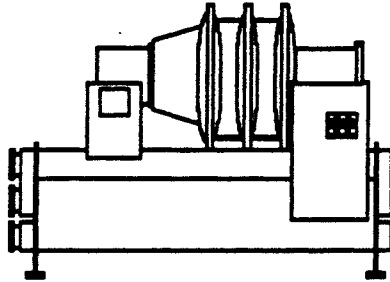

- * **Soft Load Current Limit Rate of Change**
 - Intensity (speed) of change
 - Adjustable from 0.5 to 5% per minute
 - Factory default is 5% per minute
- * **Soft Load Leaving Water Temperature Rate of Change**
 - Adjustable from 0.5 to 5 F per minute
 - Adjustable in 0.1 to 1.0 F per degree
 - Factory default is 5 F per minute

93

•See last page for description.



Service Settings

(Field Startup Group)



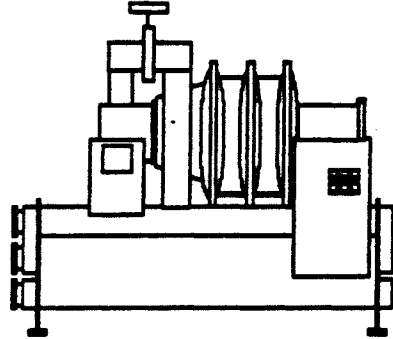

- * **Hot Gas Bypass Enable**
 - Eliminates short cycling due to light load chiller operation
 - Provides a false load to the evaporator
 - Factory default is Disable
- * **Hot Gas Bypass Cut Vane Position**
 - Range of adjustability is 0-30%
 - 1% increments
 - Factory default is 10%

94

•Hot Gas Bypass is a chiller option that is intended to reduce the capacity of a chiller at minimum load conditions by bypassing condenser gas to the evaporator. On standard chillers, minimum load is determined by the amount of gas that leaks through the inlet guide vanes when they are fully closed. By adding HGBP a portion of this gas comes directly from the condenser, thus reducing the amount of cooling done by the chiller.

•HGBP is also seen as a way to correct applications where the chiller has been oversized.

~~*~~ - not recommended to change factory settings.
Consult
Trane
Eng.



Service Settings

(Field Startup Group)



Speed

Accelerator

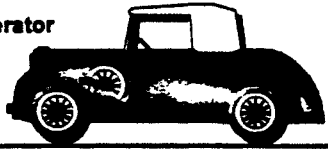

Proportional to the weight of your foot

Throttle

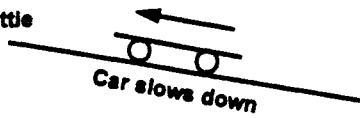

Car slows down

Vacuum



Car speeds up

PID Control

- * **LWT Proportional Gain Setpoint**
 - Adjustable range 0 to 100%
 - Factory default is 10% per degree F
- * **LWT Integral Gain Setpoint**
 - Range values 0 to 1%
 - Factory default is 0.110% per degree F
- * **LWT Derivative Gain Setpoint**
 - Range values 0 to 10% per degree F
 - Factory default is 0.0% per degree F

95

•PID = Proportional, Integral, Derivative

•Proportional = Pounds per Degree - Direct Relationship - Pressure per Temperature - 1 For 1

•Integral = Add Time to proportional

•Derivative = Add Intensity to Proportional and Integral

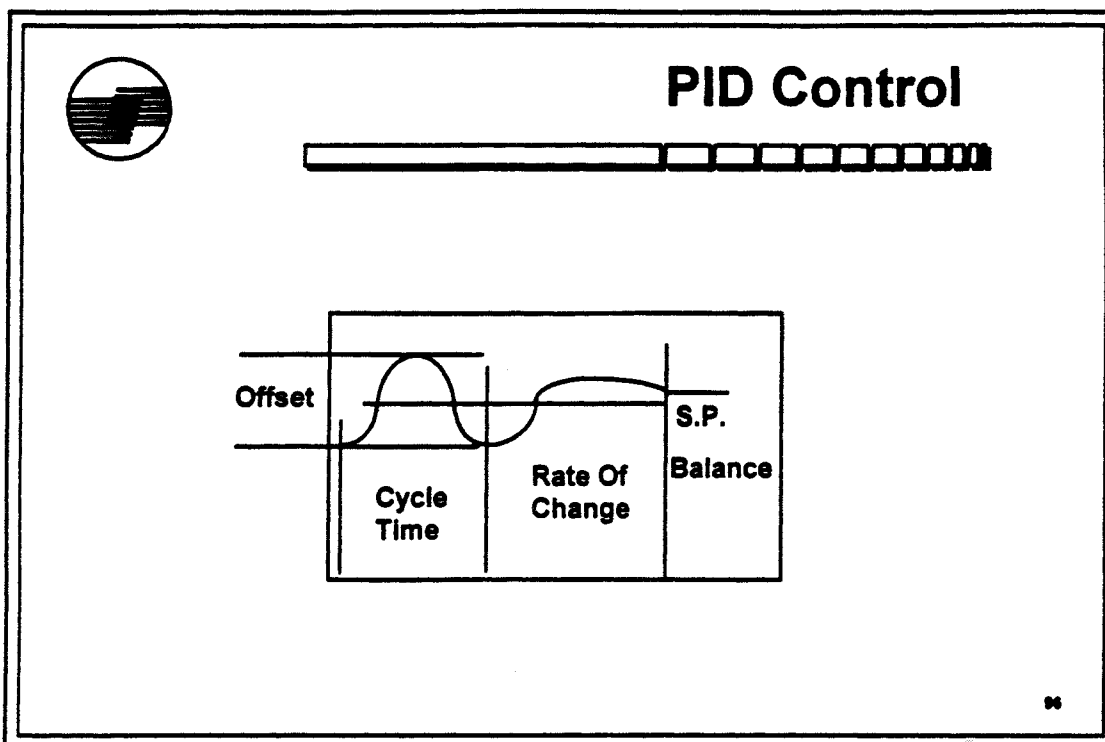

•See last Page



Service Settings

(Field Startup Group)



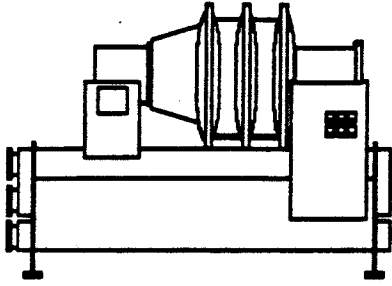

- **Inlet Guide Vanes (IGV)**
Maximum Travel Setpoint

 - Stepper Motor
 - Range 0 to 50,000 Steps
 - Increments of 100 steps
 - Factory default is 50,000 steps (90 Deg. Open)
- **IGV Maximum Travel Stop**

 - Range is 0 to 100%
 - Factory default is 0%
- **IGV Closed Travel Stop**

 - Range is 0 to 30%
 - Factory default is 0%

97

•The IGV is a stepper motor which operates at 1371 steps per second. It is at 0 steps when fully closed and 50,000 steps at full open. Each step is worth .000104 inches stroke. A total travel length is $5.195 + .375 = 5.57$ inches. There are 10,333 steps per inch.

•It calibrates itself at every shutdown and startup. It does this by overdriving to 60,000 steps.

•A BPI switch is used as a feedback loop. It tells the UCP 2 at what position the stepper motor is in compared to the stepper count.

•The maximum travel stop limits the stepper motor travel.

•The minimum travel stop Limits the stepper motor travel.



Service Settings

(Field Startup Group)



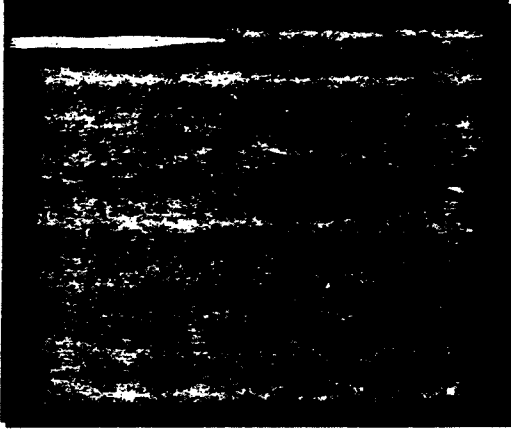

- **Min. Capacity Timer**
 - Factory default = Enable
- **Time Permitted At Minimum Capacity**
 - Factory Default = 30 Min
- **Local Atmospheric Pressure**
 - Range is 10 to 16 PSIG
 - Factory default is 14.7 PSIG

•The minimum capacity timer is a function which will allow the unit to run at minimum load for a specific time. Centravac units do not run very efficiently at low load and some units can vibrate at extended low load.

•The range value of this control is from 1 to 480 minutes. The factory default is 30 minutes.

•Centravacs are installed at sea level and at higher elevations. You must set the UCP 2 to local atmospheric pressure. All pressure temperature readings will change due to elevation.

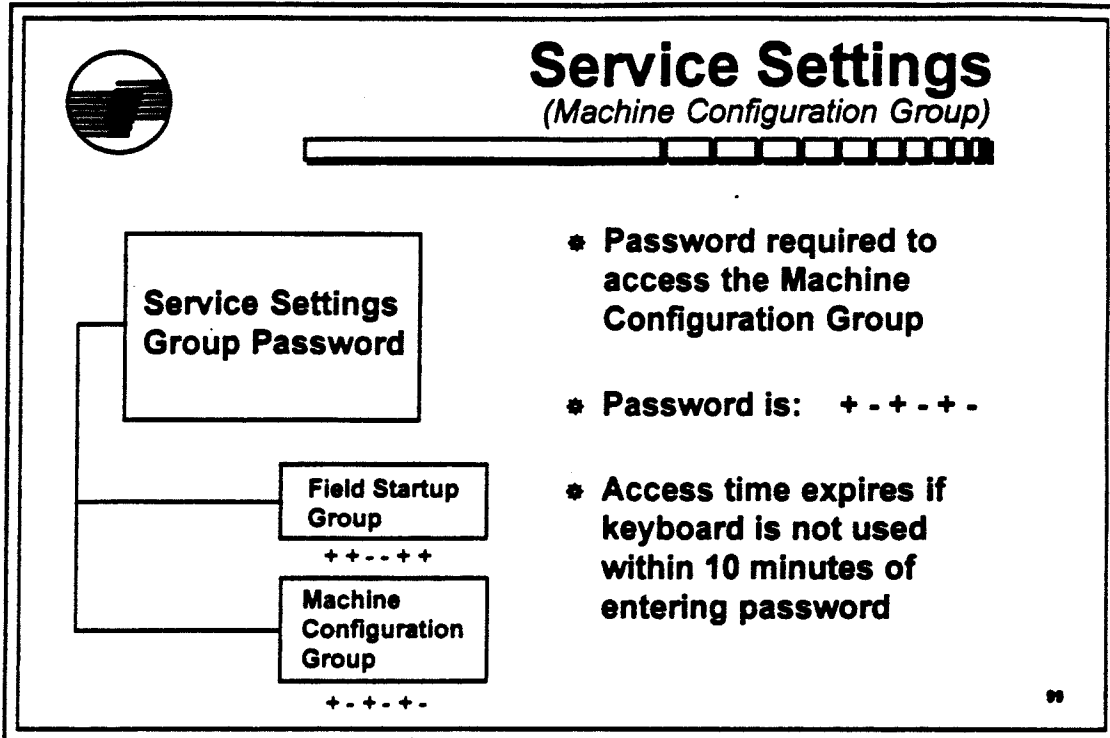

• Within the Service settings group, a password is required for Machine Configuration that is different from Field Startup. That password is + - + - + -.

• The password is only good for 10 minutes. If you do not touch the keyboard in that time, you must re-enter the password.



Service Settings Group

(Machine Configuration Group)



 **TRANE™** *Serial Data Plate*

Unit: CVHE
Tons: 1,000
Ref. Type: R - 123
Starter Type: X - Line
Rated Load Amps: 175
Unit Voltage: 480

* Machine Configuration Group Settings

- You provide data describing the chiller and how it should respond
- This is the serial data plate of the unit

100

•When configuring the machine group settings, you must think of it as telling an empty brain what it is and how it should work. Your unit has defaults preset in the control system when you receive it. You have to configure your unit to operate the way you want it to operate.



Service Settings

(Machine Configuration Group)



Unit Frequency 60 Hz
Press (+) (-) to Change Setting

- * **Unit Frequency**
 - Values are 50 or 60 Hertz
 - Factory default is 60 Hertz
- * **Unit Type**
 - Values are CVHE or CVHF
 - Factory ROM default is CVHE
- * **Unit Tons**
 - Values are 100 thru 1,600 Tons (10-Ton increments)
 - Factory default is 500 Tons

101

•You have to tell the unit what it is.



Service Settings

(Machine Configuration Group)



Refrigerant Type R - 123

Press (+) (-) to Change Setting

- * **Refrigerant Type**
 - Values are R - 11, R - 12, R - 134a, R - 22, Water
 - Factory default is R - 123
- * **Refrigerant Monitor Type**
 - Values are 01 - Analog Interface, 02 - IPC Interface
 - Factory default is None
- * **Starter Type**
 - Values are Undefined, Variable Speed, X - Line, Solid State, Auto Transformer, Primary Reactor
 - Factory default is Y - Delta

102

•The unit needs to know the above information.



Service Settings

(Machine Configuration Group)



2nd Level Contactor Integrity Test:	Enable
Press (+) (-) to Change Setting	

* Level 2 Contactor Integrity Test

- Wye contactor 2K1 is energized and circuit current is looked for.
If none is found, 2K1 is released and 2K3 is energized and current is looked for.
If none is found, the unit starts. If current is found (showing a welded, closed contactor) the unit goes into a diagnostic and locks out. This is only used on Y - Delta starters.
- Factory default is Disable

103

•When a Y - Delta starter is used, you can test the starter with an integrity test. Follow the procedure above.



Service Settings

(Machine Configuration Group)



Current Overload Setting # 1 XXXXXXXX

Press (+) (-) to Change Setting

- * **Current Overload Setting # 1**
 - RLA / CT Scale X 100 = CT Factor
 - CT Factor Compared to Table 3 = Setting # 1
 - Range Value is 00 - 31
 - ROM default is 00 See page 64-5 CVHE-M-7
 - Factory default is nameplate setting
- * **Current Overload Setting # 2**
 - SAME AS ABOVE
 - Range value is 224 - 255

105

•Use CVHE-M-7 manual at page 63, 64, 65 to describe how this calculation works. Make sure that table 1 or table 2 is used.

•Setting value 2 is the balance of setting value 1 compared to a total value of 255. This is a computer bite value calculation.



Service Settings



Formula for Current Over load Setting

RLA / CT Scale X 100 = A Number

125 / 150 = .833 X 100 = 83

Table 3 Scale - 83 -

Current Overload Setting #1 - 18

Current Overload Setting #2 - 237

**Warning, These two numbers
must always add up to 255. This
is a computer binary code.**

See Page 64,65 - CVHE - M- 7

106



Service Settings

(Machine Configuration Group)



Maximum Acceleration Timer Setpoint # 1 XX Sec.

Press (+) (-) to Change Setting

- * **Maximum Acceleration Timer # 1**
 - Range of values: 0 to 64 seconds
 - Y - Delta = 27, X - Line = 6, Variable Speed = 20, Solid State = 20, Auto Transformer = 16, Primary Reactor = 11
 - Factory default is 27
- * **Maximum Acceleration Timer # 2**
 - Range of Values 191 to 255 seconds
 - Factory default is 228 seconds

107

•The acceleration time is configured similar to the last page. You have a fixed number instead of a calculated number and acceleration timer 2 is the balance to a total value of 255.

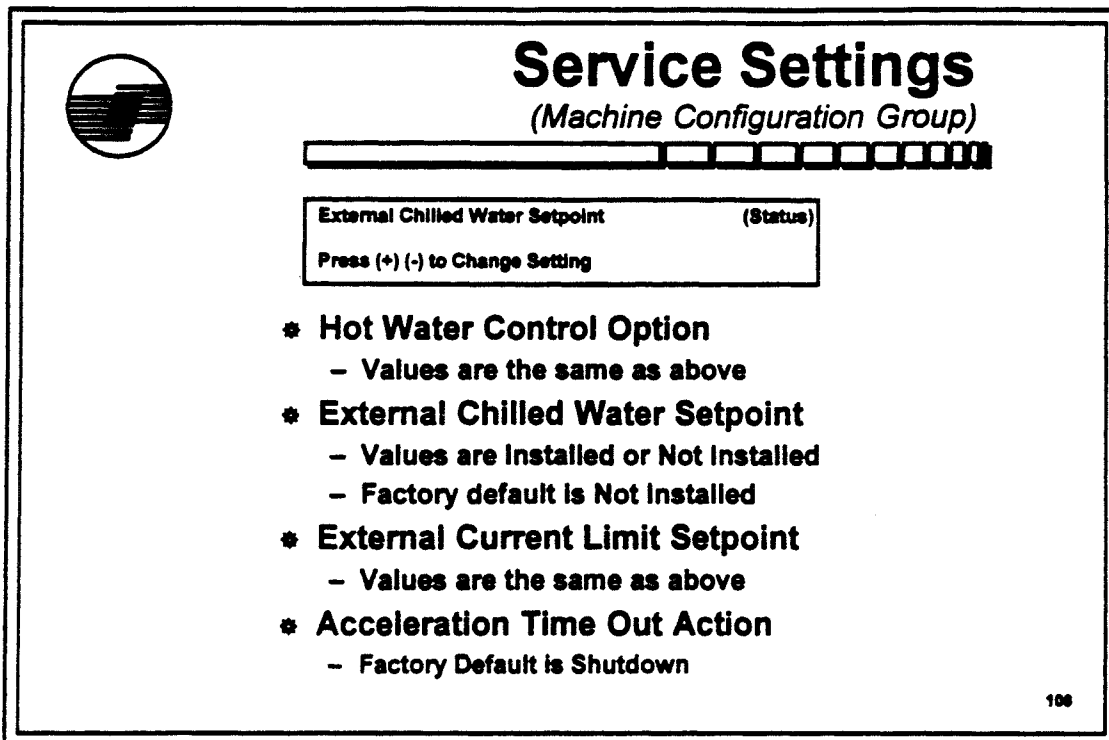

•The blue type shows options. if they are not asked for, they will not show on the screen. The screen will read Not Installed.

•When acceleration times out and the system has not started yet, how do you want the unit to respond? Factory default is to shut down the chiller. The option is to continue transition.



Service Settings

(Machine Configuration Group)



Motor Winding RTD Type (Type)
Press (+) (-) to Change Setting

- * **Motor Winding RTD. Type (Resistive Temperature Device - linear Sensor)**
 - Range is 100 Ohm At 0 C
 - Factory default is 75 Ohm at 75 F
- * **High Pressure Cutout Setting (Vessel)**
 - Range is 500 PSIG
 - Increments of 5 PSIG
 - Factory default is 15 PSIG - Standard 25 PSIG - ASME
 - Condensor Pressure Limit Cutout Range is- 80 To 120 % of vessel pressure range.

109

•If the motor winding RTD is open and the motor is not running hot, you can jump the sensor with a 75 Ohm 1/2 Watt resistor to fake out the safety. If a second RTD fails, I would look for why and install new RTD's.

•The high pressure cutout setting on a low pressure vessel should not exceed 15 PSI. If you have a high pressure vessel the control can be adjusted accordingly.



Service Settings

(Machine Configuration Group)



Line Voltage Sensing Option : (Status)

Press (+) (-) to Change Setting

- * **Line Voltage Sensing Option**
 - Values are Installed; Not Installed
 - Factory default is Not Installed
- * **Aux. Condenser Option**
- * **Heat Recovery Option**
- * **Hot Gas Bypass Option**
- * **Free Cooling Option**

110

•All the above are options. If not used, the screen will say not installed. If installed, more screens will show and extra setups are required.



Service Settings

(Machine Configuration Group)

Condenser Pressure Sensor : (Status)

Press (+) (-) to Change Setting

- * Condenser Pressure Sensor Option
- * Bearing Temperature Sensor Option
- * Discharge Temperature Sensor Option
 - Superheat vs. Subcooling
- * Ice Building Option
- * Differential Water Pressure Sensors

111

- The discharge temperature sensor option measures compressor discharge gas temperature. The range is 170 F. to 220 F. The setpoint is 200 F.
- This control protects the “O” Ring seals from being overheated.
- Normal Discharge temperatures range from Condenser Saturated Temperature of 105 F.+ 21 F. Superheat to a heat recovery/Hot Gas Bypass Temperature of 105 F. + 40 to 60 F. Superheat.
- The normal CTV compression ratio is 28 PSIA - 7.5 PSIA = 3.5 to 1.



Service Settings

(Machine Configuration Group)



- * **External Setpoint Inputs**
 - Values are 2 - 10 VDC; 4 - 20 mA
 - Factory default is 4 - 20 mA
- * **Tracer Option**
 - Values are Installed ; Not Installed
 - Factory default is Not Installed
- * **TCI Option (Tracer Communications Interface)**
 - Values are Installed ; Not Installed
 - Factory default is Not Installed
- * **Printer Option**
 - Values are Installed ; Not Installed

112

- The printer can be installed at the Centravac control panel or at the Tracer unit. This option should be used as a service tool.
- The setup of the printer is found in the Service Settings Group, between the Evaporator Pump Off Delay button and the Clear Restart Inhibit Timer.

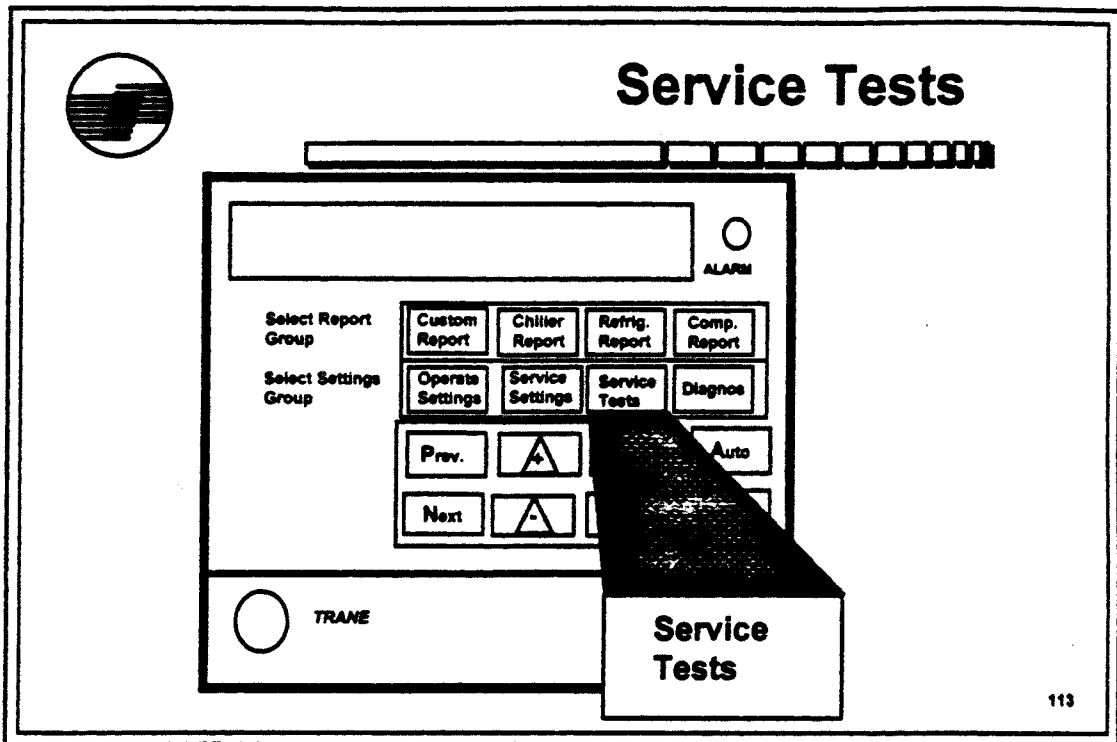

- The Service Test button provides the capability to turn components on or leave them in an automatic position.
- Turns on the chilled water pump
- Turns on the condenser water pump
- Provides a starter dry run test
- Turns on the oil pump
- Provides manual vane control
- Provides a inlet guide vane position location



Service Tests

Pswd. Req. to Acc. Service Tools Group
Please Enter Password

ALARM

Select Report Group

Select Settings Group

Custom Report	Chiller Report	Refrig. Report	Comp. Report
Operate Settings	Service Settings	Service Tests	Diagnos
Prev.	▲	Enter	Auto
Next	▼	Cancel.	Stop

★ **A password is required to access the service tools group**

- ++--++ Enter
- Items shown in this group are primarily associated with either tests or manual override of the chiller or chiller subsystems
- If this screen is not used in 10 minutes, it will revert back to Chiller Operating Mode of the Chiller Report and a password must be re-entered



TRANE

Adaptive Control

114

•A password is required to access the test group. The password is ++--++ Enter.

•If the keyboard is not stroked in 10 minutes, the password will be reset and you must re-enter the password.





Service Tests



Service Test and Overrides
Press (Next) or (Previous) to Continue

 ALARM

Select Report Group	Custom Report	Chiller Report	Refrig. Report	Comp. Report
Select Settings Group	Operate Settings	Service Settings	Service Tests	Diagnos
	Prev.		Enter	Auto
	Next		Cancel	Stop

TRANE

Adaptive Control

*** Service tools Group Heading**

- This heading will remain if other headings are suppressed in the Service Settings Menu

115

•The Service Tools Heading can be removed from the display, if desired. This would help confuse those who should not be in the system.

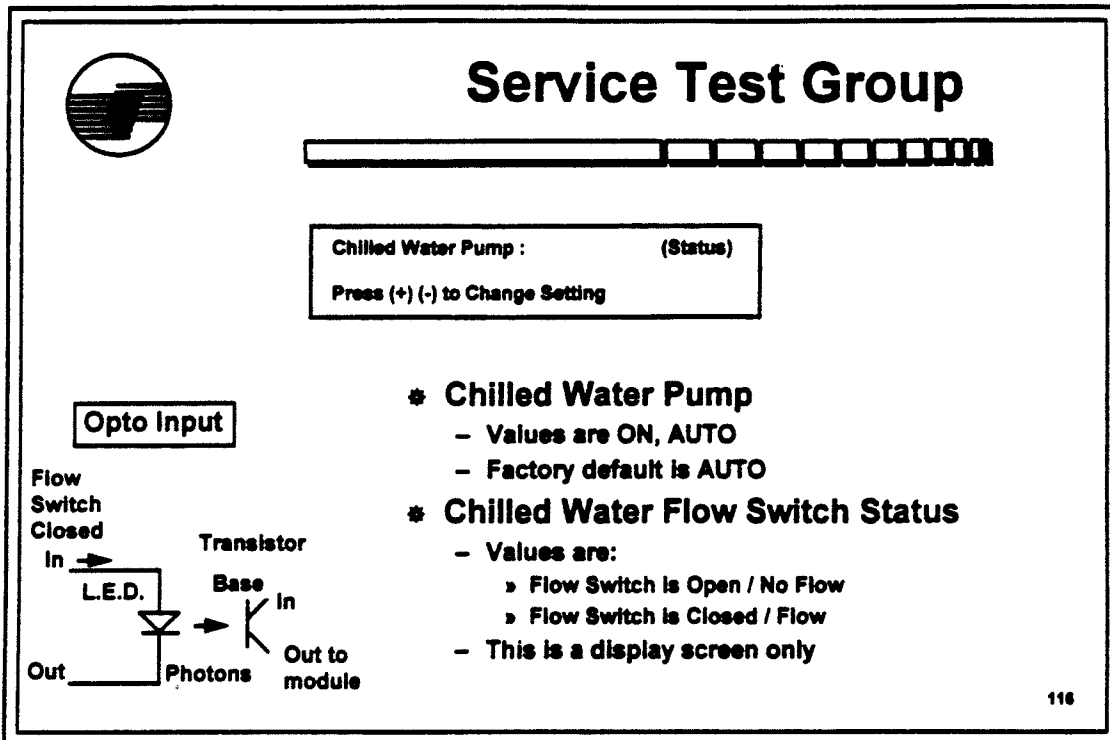

- We can turn the chilled water pump without starting the chiller. This would be used to balance the water system.
- The chilled water flow switch feeds back a signal that is seen by the chiller module through the Opto Input Transistor Circuit.
- The opto circuit sees electron flow via light emissions, when the flow switch or delta "P" switch is closed.
- Photons (Light Energy) generated by the L.E.D. radiates to the transistor base.
- The transistor base turns into a conductor that allows current flow.



Service Test Group



Condenser Water Pump : (Status)

Press (+) (-) to Change Setting

Opto Input

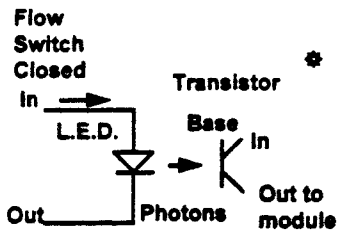

* Condenser Water Pump

- Values are ON / AUTO
- Factory default is Auto

* Condenser Water Pump Flow Switch Status

- Values are:
 - » Flow switch is OPEN / NO FLOW
 - » Flow switch is CLOSED / FLOW
- This is a display screen only

117

- When the condenser water pump is on and the chiller off, you can balance the water system.
- This control has a feedback device called a flow switch. The flow switch when closed supplies a signal to the Opto Input.
- The Opto Input tells the module flow exists.



Service Test Group



Starter Dry Run : (XX)

Press (+) (-) to Change Setting: Transition Complete Input (Y)

* Starter Dry Run

- Factory default is disable
- Unit must be in STOP to activate test
- Values for XX are:
 - » Shorting Relay On
 - » Run Relay On
 - » Start Relay On
 - » Transition Relay On
 - » Start and Transition Relays On
- Values for Y are:
 - » Closed = TCI is seeing a contact closure
 - » Open = TCI is seeing a contact open
 - » Y - Values will change on machine operation

118

- Starter Dry Run can only operate with the unit off.
- Starter Dry Run will be recognized by all starter systems.
- Starter Dry Run is based on Y-Delta Systems.
- Starter Dry Run is a function test that looks at current flowing through a contactor or not.
- This will show if a contactor is welded closed.
- During the starter dry run, the UCM shall monitor phase current and voltage. If at any time the UCM can sense current greater than the Phase Loss criteria (5% RLA for 1 Second), or greater than 50% line voltage, the test shall be terminated and a latching diagnostic generated.



Service Test Group



Oil Pump :	(Status)
Differential Oil Pressure	XX.X PSID:

* Oil Pump

- Values are ON or AUTO
- Factory default is AUTO
- Differential Oil Pressure is Active and will change

119

- During an extended down time, the bearings might become dry. Being able to turn on the oil pump is a benefit.
- Having the oil pump run continuously even if the compressor is off is not a good practice. Excess oil loss is a result of this action.



Service Test Group



Vane Control is : (Status)

Press (+) (-) to Change Setting:

* Vane Control Status and Vane Position Commands

- Values are: MANUAL and AUTO
- Factory default is AUTO
- Can operate with unit off

* Inlet Guide Vane Position if in the Manual Mode

- Value is XXX.X % OPEN
- Second Line Information is Limit Mode

> Limit Mode Values are:

- Current limit
- Condenser Limit
- Evaporator Limit

Inlet Guide Vane Position : XXX.X % Open
(Limit Mode)

Vane Position XXX.X % Target XXX.X % Open
(Limit Mode) (+) (-) to Change Target

Inlet Vane Guide Position : XXXX Steps
Inlet Guide Vane Position : xx.x Degrees

120

•This manual command allows you to place the vanes in any position you like. From full closed to full open.

•The next screen tells you the vane position, the leaving water temperature, and the target position that you are changing.

•As the target is changed, the vane position will change. This change is very fast.

•WARNING:

The vanes will stay in this position until you change the command. If a safety condition occurs, the unit will respond to that condition by stopping on a default.



Service Test Group



RTHB

Expansion Valve Test : (Status)
Press (+) (-) to change Setting

Expansion Valve Control is: (Status)
Press (+) (-) to change Setting

Expansion Valve Position is: XXX.X % Open
This display is shown if in AUTO position

EXV Position is : XXX.X % Target XXX.X % Open
LWT = XX F. (+) (-) and (Enter)
This display is shown if in MANUAL position

* EXV Test

- Can be enabled if in LOCAL / STOP
- Values are: DISABLE AND ENABLE
- Factory default is ENABLE

* EXV Control

- Values are AUTO or MANUAL
- Factory default is MANUAL

121

- This control is used on the RTHB series unit.
- You can test the action of the valve against time.
- The chiller must be in the stop mode for this test.
- If the EXV EIT test is unsuccessful, a diagnostic will indicate the failure.
- No diagnostics are associated with the timing test, however, the operator may listen to determine if the EXV ratchets against the valve mechanical stops when expected.
- 130 - 215 Tons
Ratchet for 15 seconds
Close normally for 10 seconds then ratchet for 5 seconds.
Open normally for 10 seconds then ratchet for 5 seconds.
- 255 - 450 Tons
Ratchet for 15 seconds
Close normally for 13 seconds then ratchet for 2 seconds.
Open normally for 13 seconds then ratchet for 2 seconds.



Service Test Group



RTHB

Expansion Valve Position :	XXX.X % Open
Discharge Superheat :	XXX.X F.

Expansion Valve Position :	XXX.X % Open
Expansion Valve Position :	XXXX Steps Open

Slide Valve Control is :	(Status)
LWT = XX F. (+) (-) and (Enter)	

Manual Load / Unload Duty Cycle :	XX %
Press (+) (-) to Change Setting	

- * **Valve Position / Superheat**
- * **EXV Position / Steps**
 - 50,000 Steps are available
- * **Slide Valve Control / Manual Load and Unload Commands**
 - Values are:
 - » Factory default is AUTO
 - » Hold
 - » Load
 - » Unload
- * **Manual Load / Unload Duty Cycle**
 - Values are: 0 to 50 %
 - » Based on a 5 minute DUTY CYCLE¹²²

- These screens are automatic. Read and describe.
- RTHB - EXV maximum steps are 50,000.
- RTHB - EXV default steps are 2,760 for 255 - 450 Tons
- RTHB - EXV default steps are 2,040 for 130 - 215 Tons
- When in manual, the EXV position is shown and the target value is added by you.
- Compressor discharge superheat should be 21 to 30 Degrees F.
- Model "R" slide valve command can be:
 - AUTO
 - HOLD
 - LOAD
 - UNLOAD
- Duty cycle is used for

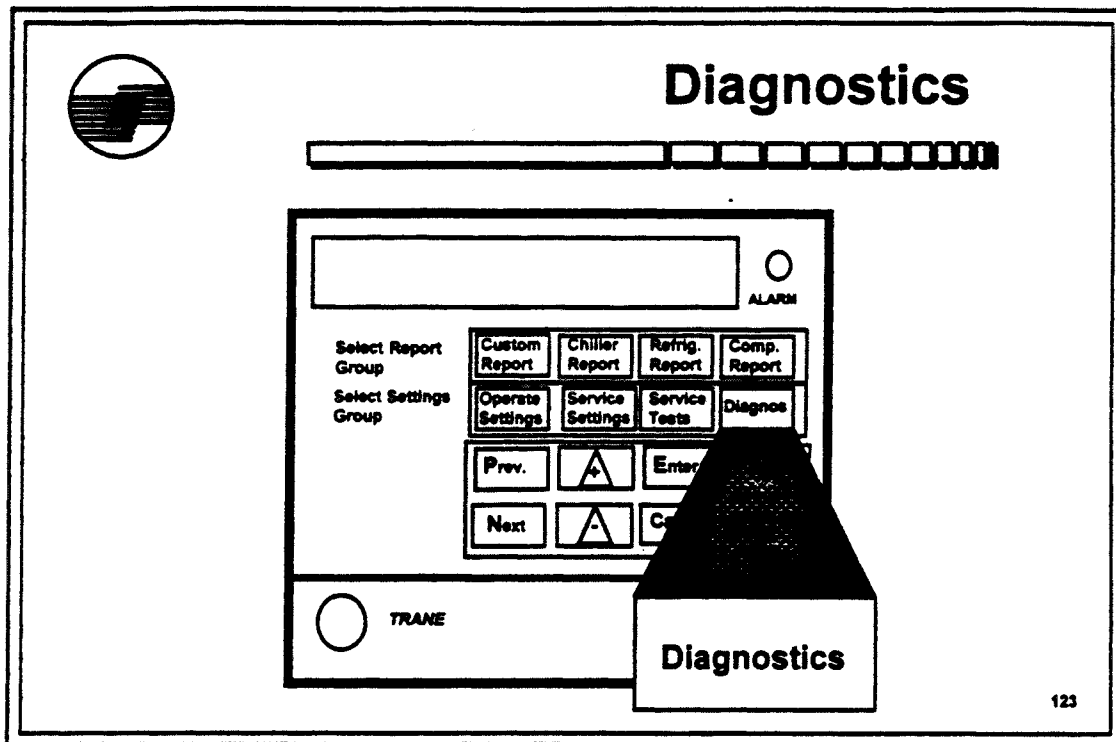

- The diagnostics group is where all diagnostics, both active and historical are presented.
- The group has the facility to clear active diagnostics, historical diagnostics and purge diagnostics.
- A total of 20 Diagnostics can be stored in both active and historical displays.
- If 5 diagnostics are in historical, then only 15 can be in active.
- As active diagnostics are identified and the 20 memory units are full, historical (Typically the oldest) diagnostics are removed.



Diagnostics

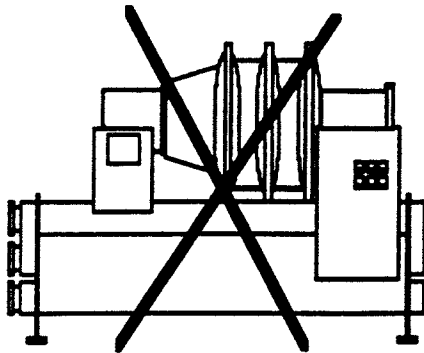

* Three Types of Diagnostics

- Warning Only - Reset not required -
(Applies to all IFW - Informational Warning)
- Unit Shutdown - Automatic Reset
(Applies to all MAR - Machine Auto Reset Diagnostics)
- Unit Shutdown - Reset Required
(Applies to all MMR - Machine Manual Reset Diagnostics)
- MMR = Lockout

124

- All active diagnostics will be lost on a loss of power.
- All diagnostics can be cleared from the local CLD.
- Most diagnostics can be reset from the remote display. 20 diagnostics cannot be reset from the remote display. They are all MMR diagnostics.
- CMR and CAR diagnostics are used in the RTAA multiple compressor units.
(C= Circuit)



Diagnostics



Group Heading and Password

Active & Historic Diagnostics
Press (Next) (Previous) to Continue
Settings In This Menu Are (Locked)
Enter Password to Unlock - + - + - +
Diagnostics and Annunciation
No Diagnostics or Diagnostic Report
Press (Next) to Display Operating Mode
((Sequence # 1) (Diagnostic Message)
Next (Diagnostic Type)
((Sequence # 1) Occurred At: Time/Date)
(Help Message)
History
((Sequence Number) (Diagnostic)
Historic Only, Press (Next) For More
((Sequence # 1) Occurred At: Time/Date)
Hist. Only, Reset At End Of Diag. Menu

- * Diagnostics are Password Protected if called out in menu settings
- (- + - + - +)
- * 20 diagnostic messages can be stored
- * As a new message appears the last stored message is lost
- * Diagnostic measurements are sequential in groups

125

- The messages are numbered from 1 to 20.
- A call out is listed as IFW or MAR or MMR
- The time and date of the diagnostic is entered.
- Instructions are listed after time and date



Diagnostics



If Active Displays are Present

Press (Enter) To Clear Active Diag.	}
and Shutdown / Reset System	
Active Diagnostics Have Been Cleared	
System Is Resetting	}
If Historic Displays are Present	
Press (Enter) To	
Clear Historic Diagnostics	}
Historic Diag. Have Been Cleared	
Diagnostic Report Is Being Reset	
If Purge Displays Are Present	}
Press (Enter) To	
Clear Purge Diagnostics	
Purge Diagnostics Have Been Cleared	}
Diagnostic Report Is Being Reset	

* Clearing Diagnostics

- End of the active diagnostics menu 3 screens appear that allows the user to clear the memory
- Active screens are removed by pressing (Enter) key 2 seconds
- Historic screens are removed by pressing (Enter) key 4 seconds
- Purge screens are removed by pressing (Enter) key 4 seconds
- The screen will reset to the operating mode screen of the chiller report

126

- Diagnostic displays cannot be reset with out turning the chiller off.
- The last diagnostic displays call out reset information.

Refer to CVHE-M-7Page 100 for all diagnostic call outs and help messages.

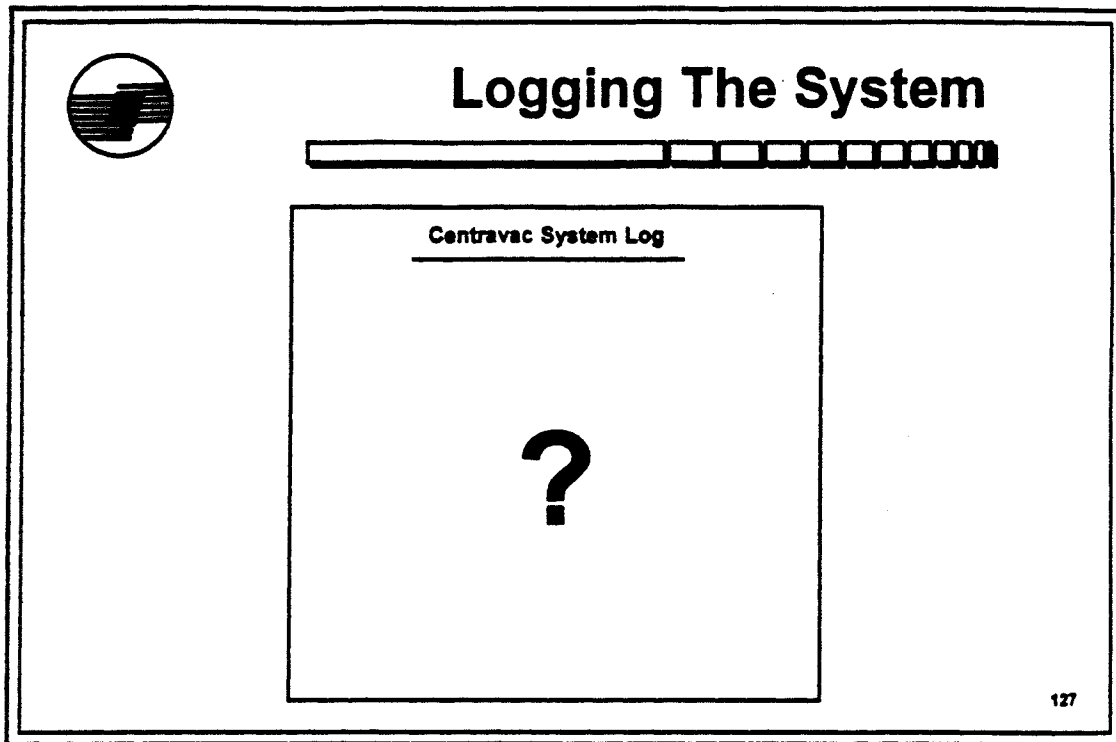

- What do you do with a system log ?
- Does it go into the round file ?
- Does anyone read it ?
- What good is a log ?

Push Buttons

Scream

Owner Or Operator

Where Do I Start

Push

Pull

Yell

128

- When you start a log, where do you start ?
- What do you use as a reference ?

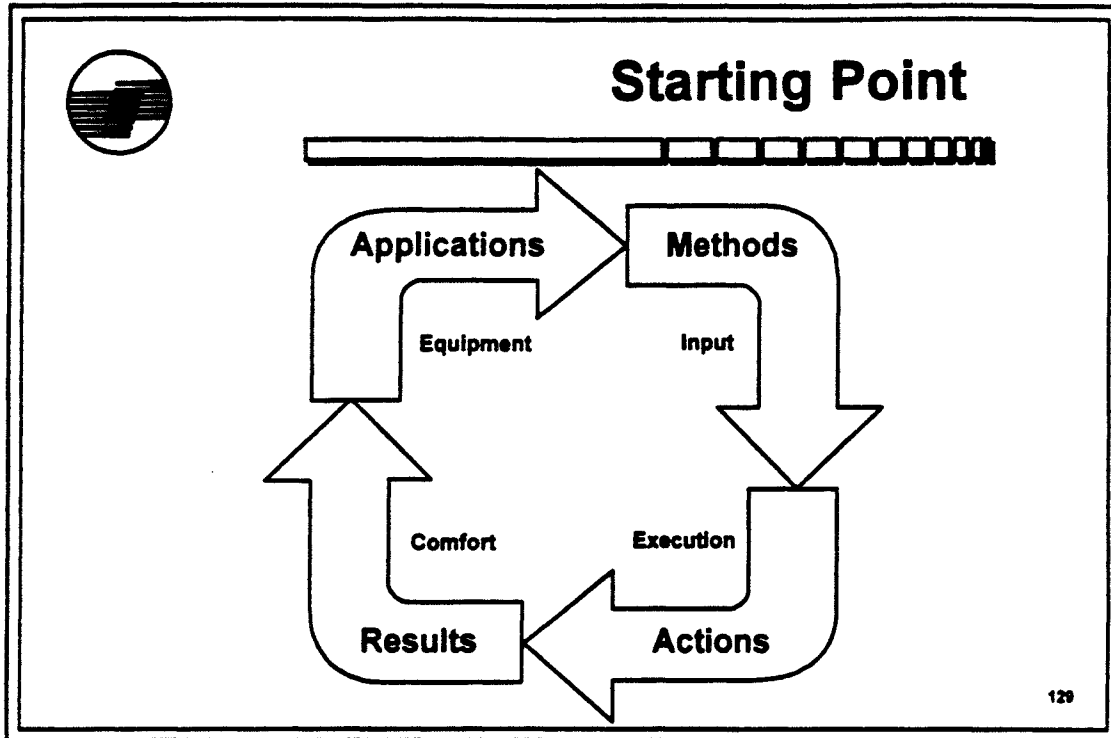

- Many things must be thought about when working with a log.
- Do you know the equipment ?
- Do you know what it was designed for ?
- Do you know how it is applied ?
- Do you know what will be the result of a failed chiller ?
- Do you even care ?



User Defined Custom Report

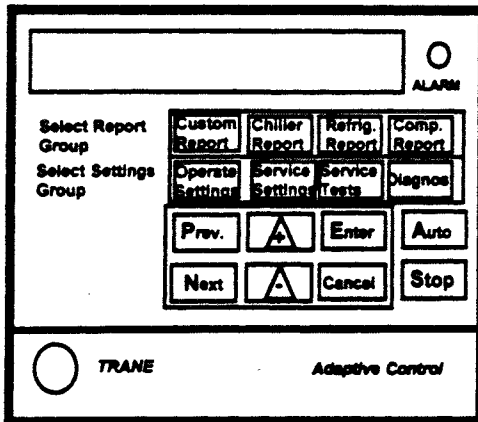

1. Press Custom Report Key
2. Scroll through Desired Reports And Press (+) To Enter Report Status.

3. To Remove Report, Press (-) Key

This Provides The Ability To Log Preset Points For Your Use

130

- Do you want to design a custom log ?
- What is important to information to obtain ?
- Remember, you have only 20 slots to fill in your custom report.



Custom Reports



What Can We Choose From?

131

- How many points of information can we choose from ?
- Over 60 Sets of Values.



Chiller Report



- *Active Chilled Water Setpoint/ Evaporator Leaving Water Temperature
- *Active Chilled Water Setpoint/ Chilled Water Setpoint Source
- *Active Ice Termination Setpoint/ Ice Termination Setpoint Source
- *Evaporator Entering And Leaving Water Temperatures
- *Condenser Entering And Leaving Water Temperatures
- *Active Current Limit Setpoint
- *Active Current Limit Setpoint/ Current Limit Setpoint Source
- *Evaporator Water Flow/ Condensor Water Flow
- *Chiller Tons
- *Outdoor Temperature
- *Auxiliary Bundle Or Heat Recovery Temperatures
- *Chilled Water Setpoint Source
- *Current Limit Setpoint Source
- *Hot Water Setpoint Source
- *Ice Termination Setpoint Source

132

- Here is 15.
- What's important to you.



Refrigerant Report



- *Evaporator And Condenser Refrigerant Pressure
- *Saturated Evaporator Temperature/ Evaporator Refrigerant Pressure
- *Saturated Condenser Temperature/ Condenser Refrigerant Pressure
- *Saturated Evaporator Temperature And Discharge Temperature
- *Purge Operating Mode/ Purge Status
- *Purge Alarm Message
- *Purge Suction Temperature/Purge Liquid Temperature
- *Purge Pumpout Rate/ Purge Maximum Pumpout Rate
- *Purge Total Pumpout Time/ Purge Total Pumpout Time
- *Purge Adaptive Cycle Time w/Chiller On/ Time To Purge Remaining
- *Purge Adaptive Cycle Time w/Chiller Off/ Time To Purge Remaining
- *Purge Service Log
- *Pumpout Average Last 30 Days
- *Refrigerant Monitor (ASHRAE 15 - Building Code)

133

•Here is 15 more.



Compressor Report



- *Differential Oil Pressure/ Oil Temperature
- *Compressor Speed Command
- *Discharge Oil Pressure/ Tank Oil Pressure
- *Inlet Guide Vane Position
- *Compressor Phase Currents % RLA
- *Compressor Phase Currents Amps
- *Compressor Phase Voltages
- *Compressor Power Factor And Watts
- *Compressor Winding Temperatures/Phase
- *Compressor Starts And Running Time
- *Bearing Temperatures #1 And #2
- *Solid State Starter Heat Sink Temperature
- *Hot Gas Bypass Time

134

•Here is 15 more.



Information



***How can this information help us ?**

135

- To take a log is only the first step.
- Proper interpretation of the log is a must.



Information Example # 1



1. Active Chilled Water Setpoint/ Evaporator Leaving Water Temperature
2. Evaporator Entering And Leaving Water Temperature
3. Condenser Entering And Leaving Water Temperature
4. Active Current Limit Setpoint
5. Evaporator Water Flow/ Condenser Water flow
6. Outdoor Temperature
7. Saturated Evaporator Temperature/ Evaporator Refrigerant Pressure
8. Saturated Condenser Temperature/ Condenser Refrigerant Pressure
9. Differential Oil Pressure/ Oil Temperature
10. Discharge Oil Pressure/ Tank Oil Pressure
11. Inlet Guide Vane Position
12. Compressor Phase Currents - Amps
13. Compressor Phase Voltages
14. Compressor Winding Temperatures
15. Bearing Temperatures #1 - #2

What Do You
Want To Choose

136

•Let's make a custom log to your choice.



Custom Reports for Logging

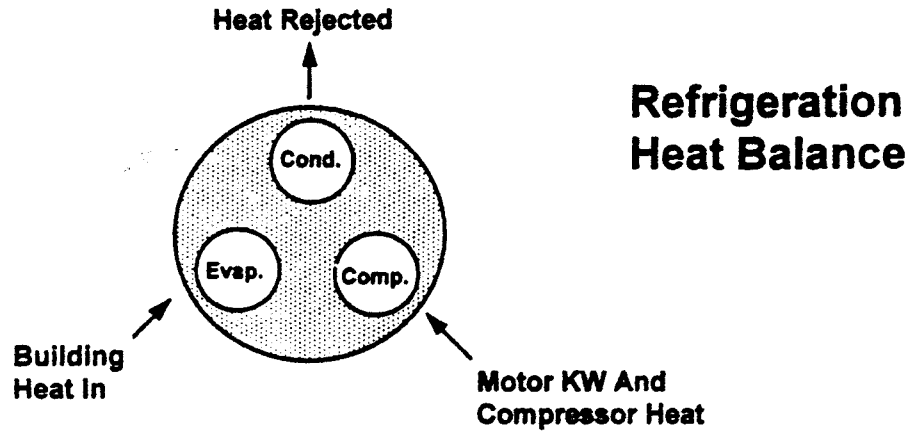

137

- What is a heat balance ?
- How do you work it.
- What does it tell you ?



PSIG to Pressure in Feet Of Head



- > 1 PSIG = 27.999 Inches Water Column
- > 27.999 Inches W.C. = 2.3 Feet of Head
- > Delta " P " = PSIG IN - PSIG OUT
- > Delta "P " = Net Pressure Drop

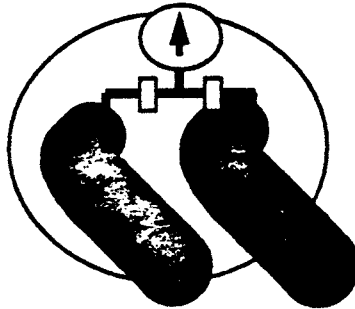

138

- To compute GPM start with delta "P".
- Convert pressure to feet of head.
- Compare feet of head to coil chart.
- Check the tube passes and chiller size.



GPM Coil Chart



11 PSID X 2.3 = 25 Ft. of Hd.

2 Pass
Size 5
Condenser

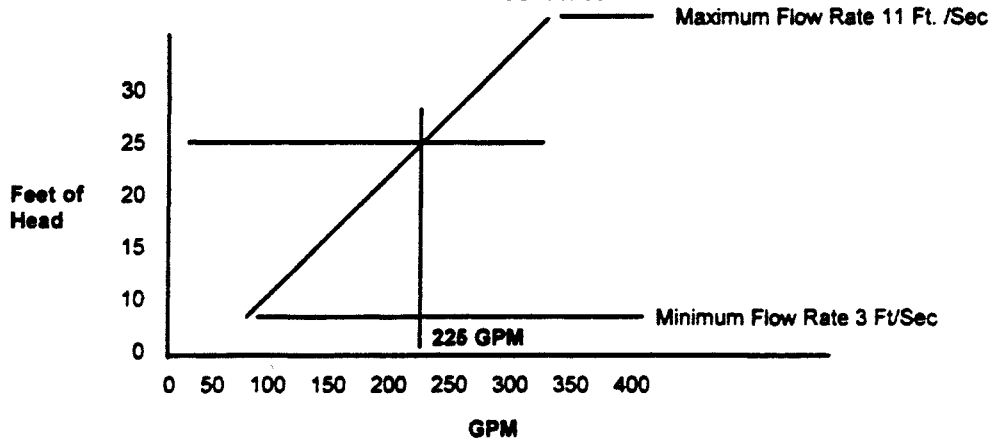

139

- Obtain delta "P"
- Convert to Feet of Head.
- Match Feet of Head to Coil.
- Drop down to get GPM.



Heat Balance Formula



Evaporator + Motor = Condenser

$$\frac{\text{GPM} \times \text{TD}}{24} + \frac{(\text{K.W.}) \times 3413}{12,000} = \frac{\text{GPM} \times \text{TD}}{24}$$

140

- This is how a heat balance works.
- Describe the slide.
- If the total is within 5%, every thing is ok.

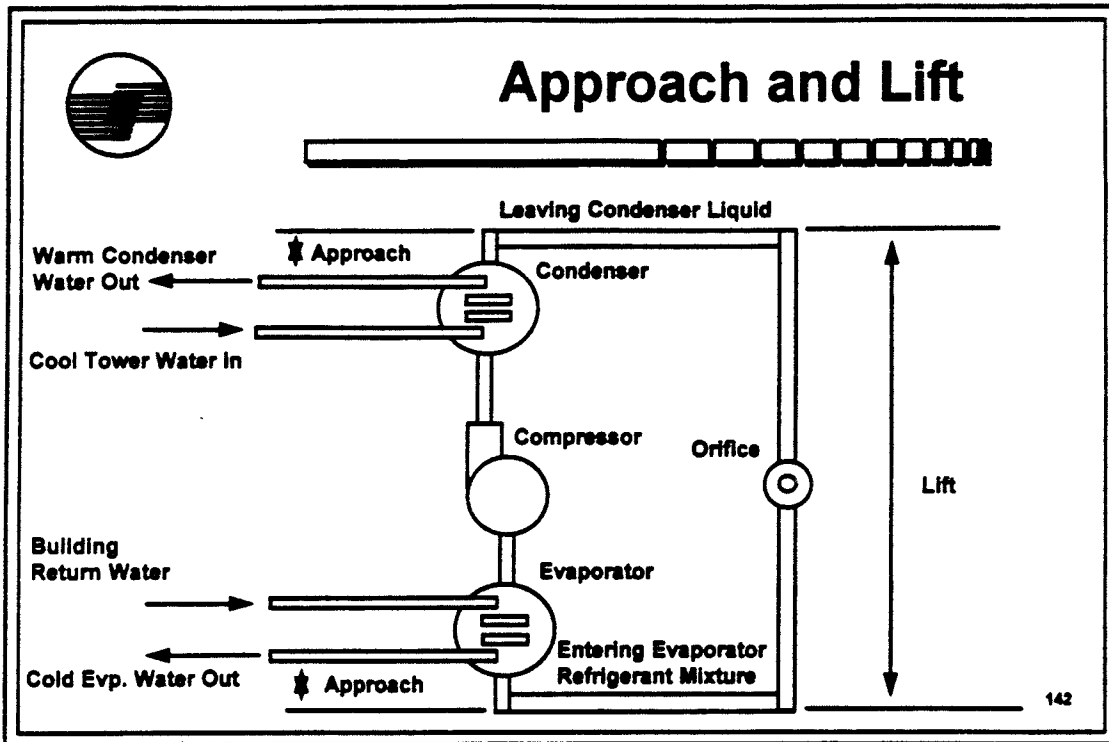

- Describe the term approach.
- Describe the term lift.

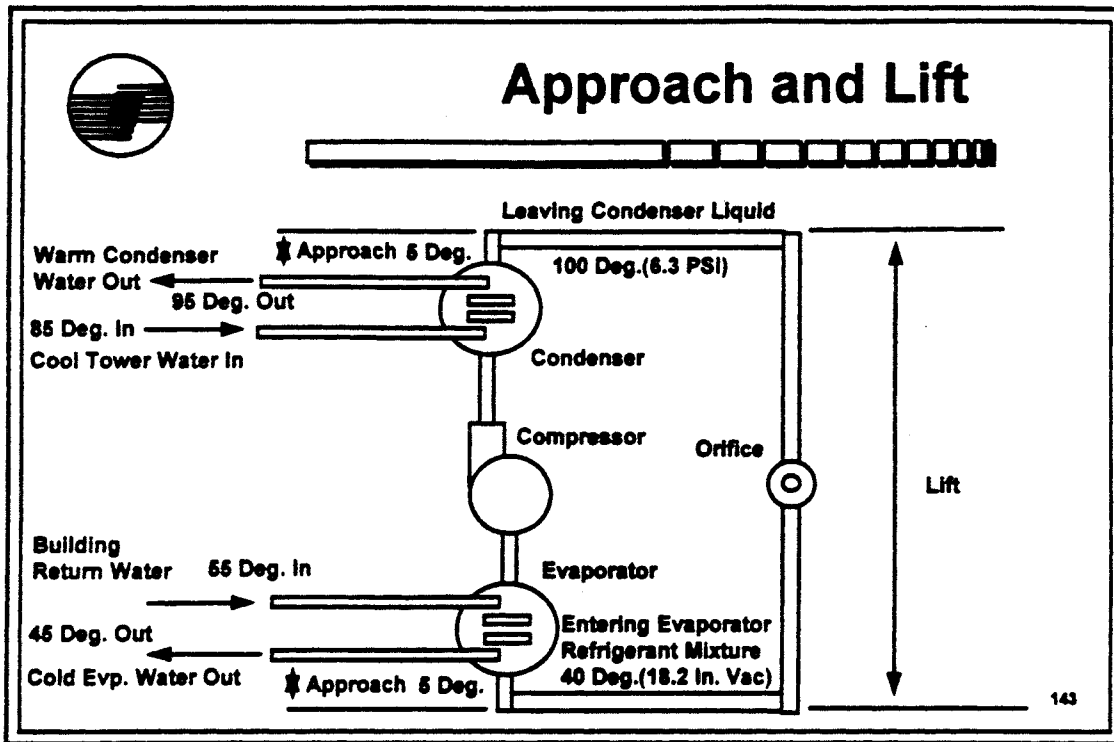

•Put numbers in the proper location and describe what you see.



What input is Necessary ?



**Logging is obtaining input,
Writing it down,
Thinking About It,
Deciding if it is GOOD or BAD
Compared to normal.**

"Logging Takes Time And Costs Money"

144

- A log represents what the unit is doing today.
- You compare the new log to the startup log when the unit is new.
- A startup log copy should be in the file at the job site.
- A copy should be at the local Trane Office.
- A Unit Specification should be at Trane Co. Lacrosse, Wis.



Energy Use Vs. Water Flow



1. Condenser Water Flow
2. Condenser Entering And Leaving Water Temperatures
3. Saturated Condenser Temperature/ Condenser Refrigerant Pressure

Compare This Input
With The Startup log

Chiller Startup Log

Condenser Water Pressure Differential
Condenser Inlet Water Temperature
Condenser Leaving Water Temperature
Condenser Water Flow - GPM
Evaporator Water Pressure Differential
Evaporator Inlet Water Temperature
Evaporator Leaving Water Temperature
Evaporator Water Flow - GPM

145

•When looking at energy use compared to water flow, certain readings must be taken.



Energy Use Vs. Water Flow

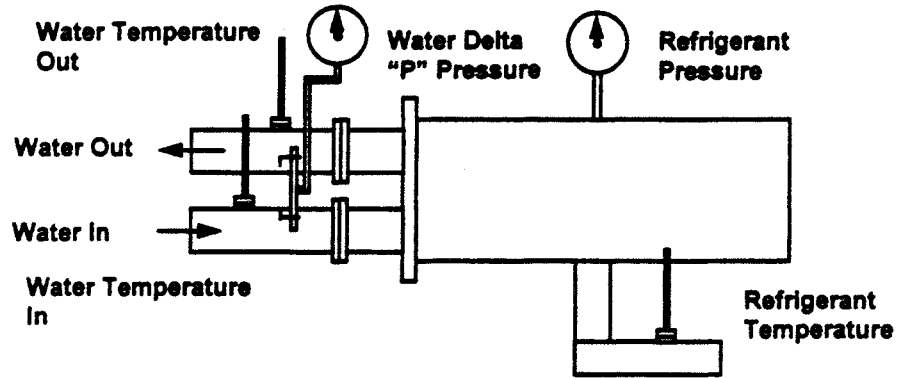

146

- This is a normal system.
- It has delta "P" gages
- It has temperature gages



Energy Use Vs. Water Flow

(Nominal Conditions)



What type of refrigerant is it using ?

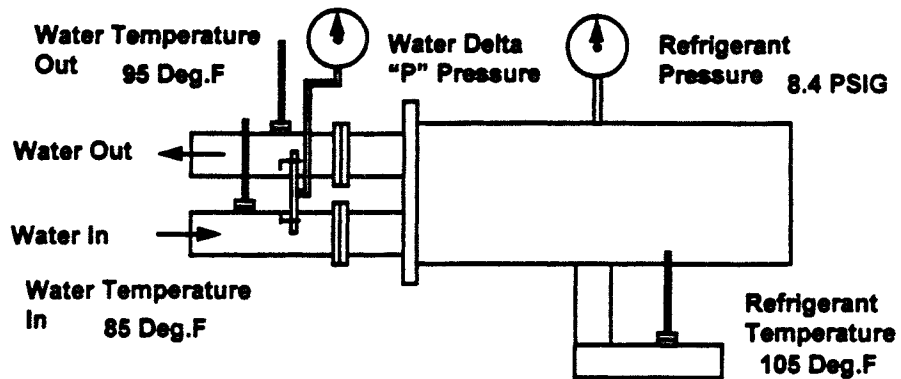

147

- Let's put some numbers on the example.
- This is a nominal System.
- What type of refrigerant is it using ? Get your P/T chart out.

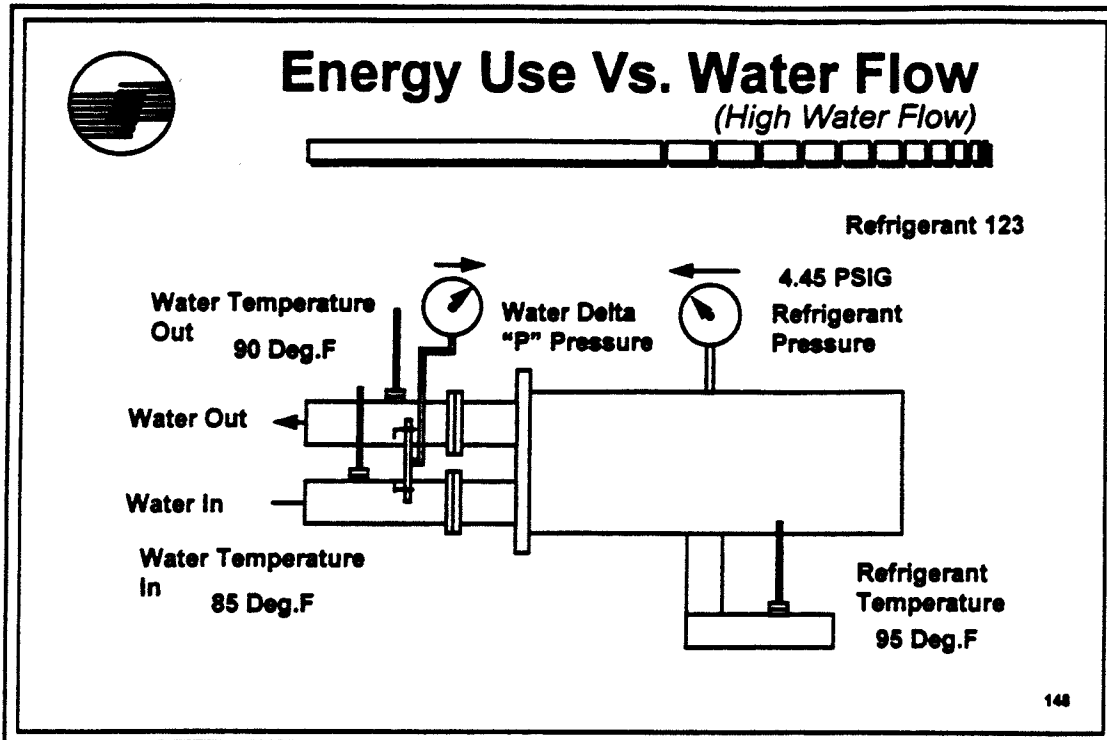

- Too much water flow.
- Water delta "T" is low.
- Water delta "P" is high.
- Refrigerant pressure is low.
- Leaving refrigerant temperature to tower water differential is low.
- Efficiency is high.

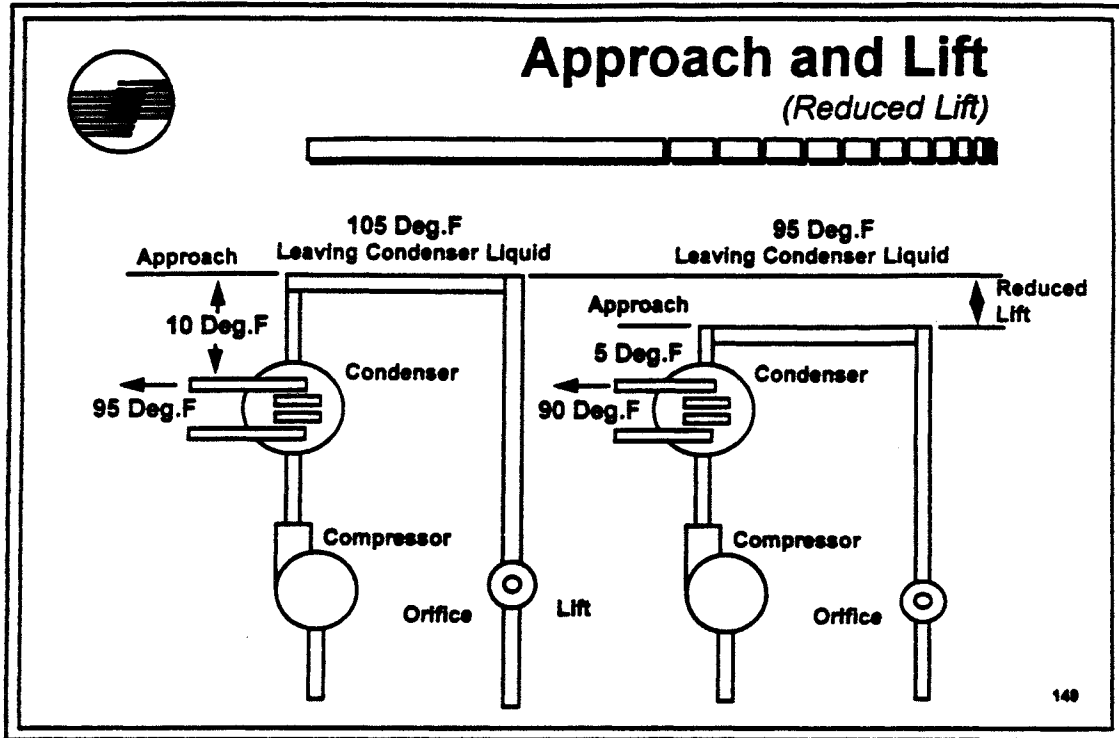

- The approach is less.
- The lift is reduced.
- More energy savings occurs.



Lift Vs. KW



**A 1 Deg. F Reduction In Lift Results In
A 1% Reduction In Motor KW**

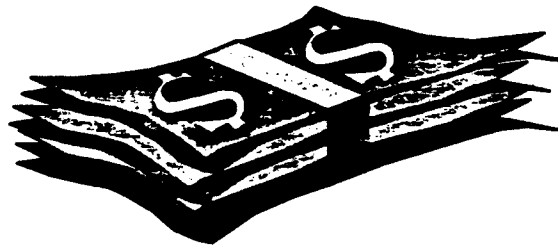

150

•As lift is reduced, motor kw is reduced and cost is reduced. 1 for 1 ratio.



Compressor Motor Problem



Read This:

1. Compressor Phase Currents - AMPS
2. Compressor Phase Voltages
3. Compressor Phase Currents % - RLA

Get This:

Voltage And Current Unbalance
Kilowatts Power
Percent Power Factor

181

- Electrical measurements are important and can be used to locate a problem.



Compressor Motor Problem



Voltage And Current Unbalance

100 X the Sum of the Deviation of the Voltages, (Currents),
Divided by 2 X the Average

The Unbalance Should Not Exceed 2% Voltage or 10 % Current

Example:

Measured Voltages :		Sum of the Deviation:	
480 Volts		480 - 470 = 10	
470 Volts	Average: = 470 Volts	470 - 470 = 0	2,000 : 2 X 470 = 2.13 %
460 Volts		470 - 460 = 10	
		20 X 100 = 2,000	

152

•Describe the slide and the formula.



Contamination Problem



1. Saturated Condenser Temperature / Condenser Refrigerant Pressure

Refrigerant Pressure / Temperature		
Refrigerant	R - 123	R - 11
Temp.	Pressure	Pressure
30 Deg.F	20.8	18.6
40 Deg.F	18.2	16.6
50 Deg.F	16.0	12.0
60 Deg.F	11.2	7.8
70 Deg.F	6.6	2.8
80 Deg.F	1.1	1.3

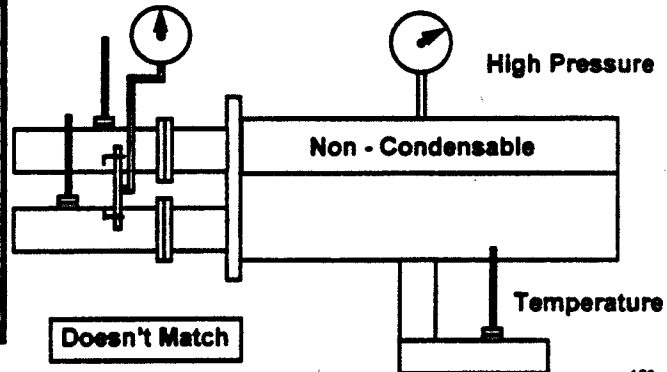

153

- When air is in the system, the law of partial pressures applies.
- Air at it's pressure/temperature point and refrigerant at it's pressure/temperature point are additive.
- The refrigerant pressure/temperature card will show the saturated refrigerant pressure/temperature relationship, but not the air.
- Any pressure that's above the pressure/temperature relationship shows a problem.
- Air will be found in the condenser rather than the evaporator.

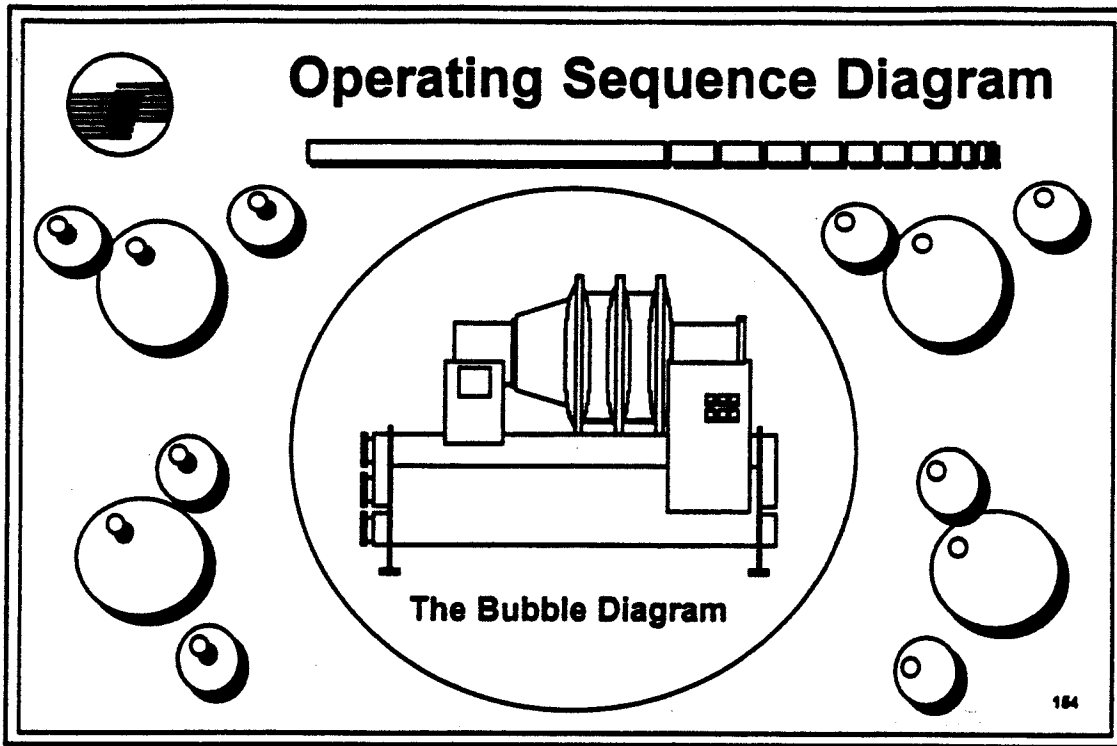

- The Bubble Diagram is designed to provide a fast basic method of instruction that shows how the system operates.
- The following slides sectionalize the sequence of operation.

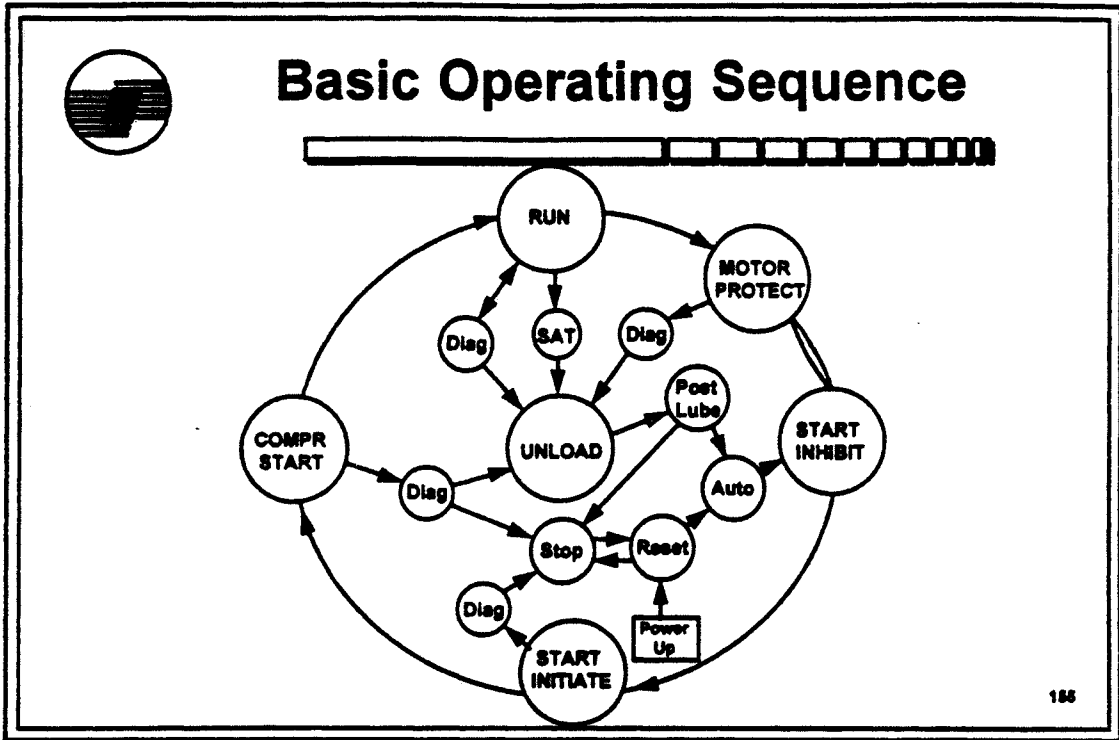

- This diagram is an all inclusive view that shows the full operation of the system.
- As you notice, a series of bubbles make up the schematic drawing.
- Follow the bubbles.

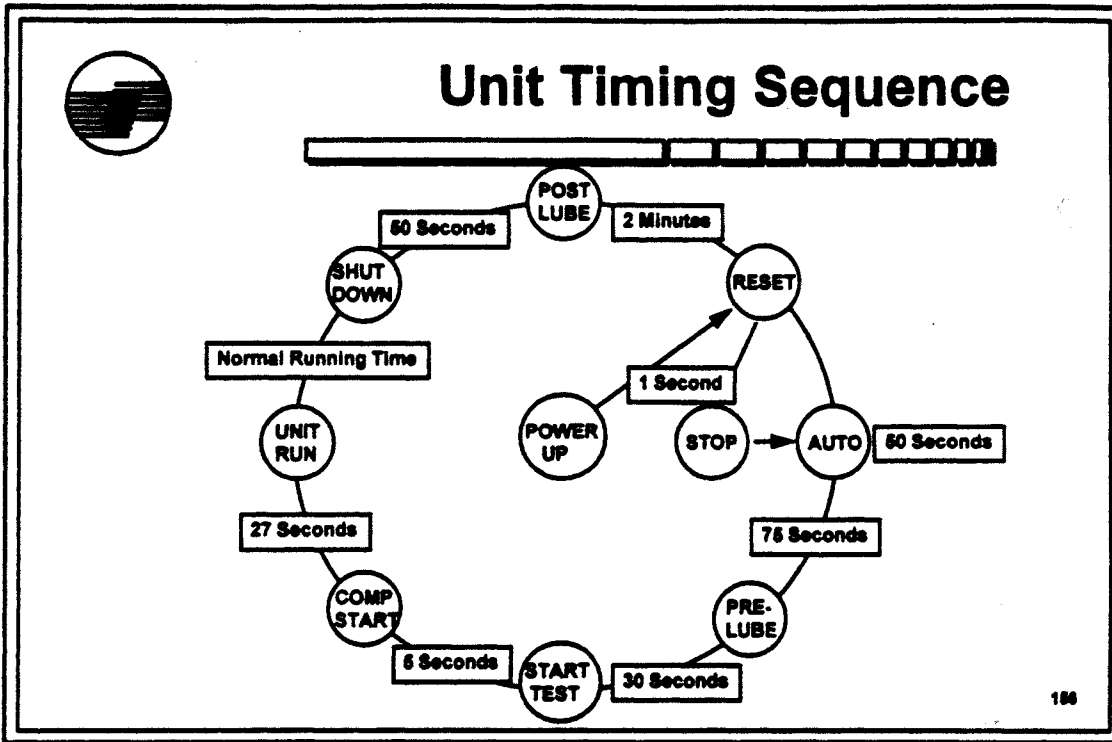

- This chart shows timing from startup to shutdown.
- Notice that it takes about 2 to 3 minutes to start and stop a Centravac.

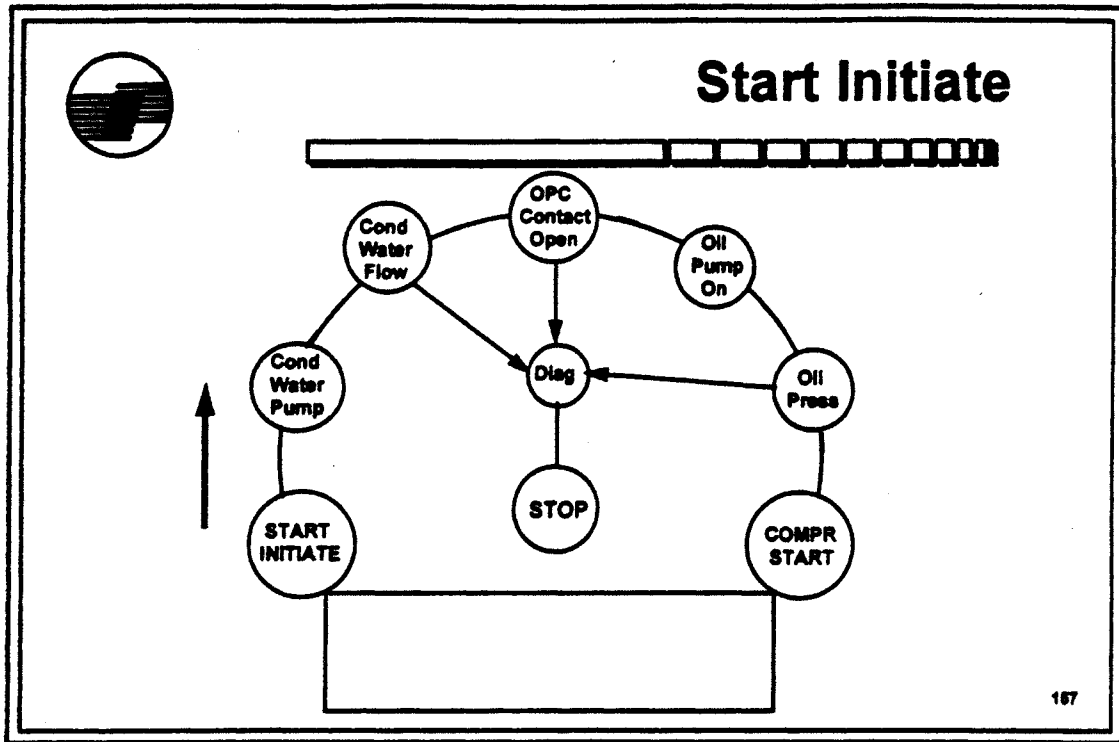

167

- From start initiate to compressor start many commands must occur.
- Describe the operation as presented.

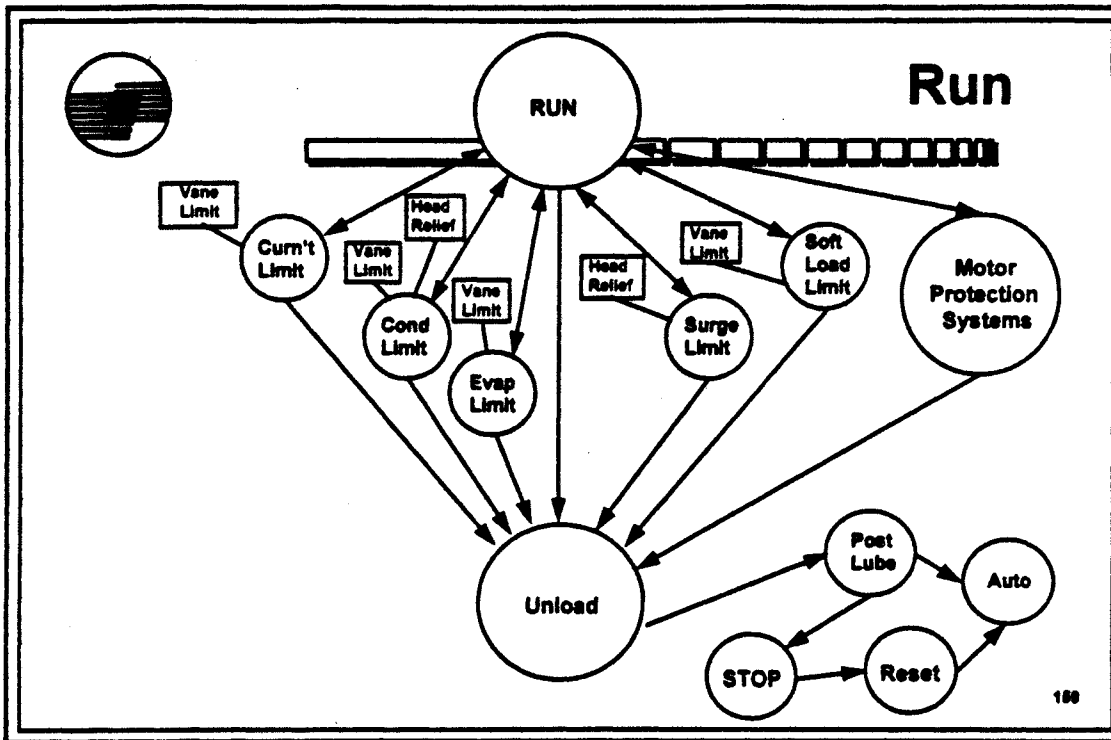

- This is the run mode.
- All run functions have safeties.
- As you notice, most problem areas utilize a vane limit function that closes the vanes as trouble increases. The main objective is to keep the chiller on line, not shut down.
- Example:

Current Limit

- Current Limit must hold at 102% RLA
- Current Limit must trip in 20 Sec. at 112% RLA
- Current Limit must trip in 1.5 Sec. at 140% RLA

During this time the vanes will be unloading at a faster rate based on the increase of amperage. ie: 1 Sec. drive/5 Sec. off

- 2 Sec. drive/5 Sec. off
- 3 Sec. drive/5 Sec. off
- 4 Sec. drive/5 Sec. off
- 5 Sec. drive/5 Sec. off
- Full Drive Closed/System off



Module Input / Output Values

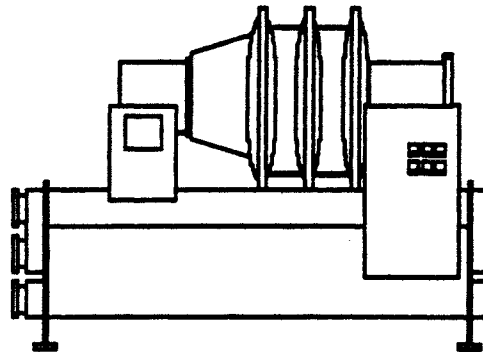

CTV

160

•This section is a fast reference guide that will help you obtain the individual voltages of each circuit.

•Many voltages are represented :ie:

0 to 5 VDC

0 to 26 VDC

24 VAC

120 VAC

•WARNING!!!!

NEVER JUMP A/C TO D/C

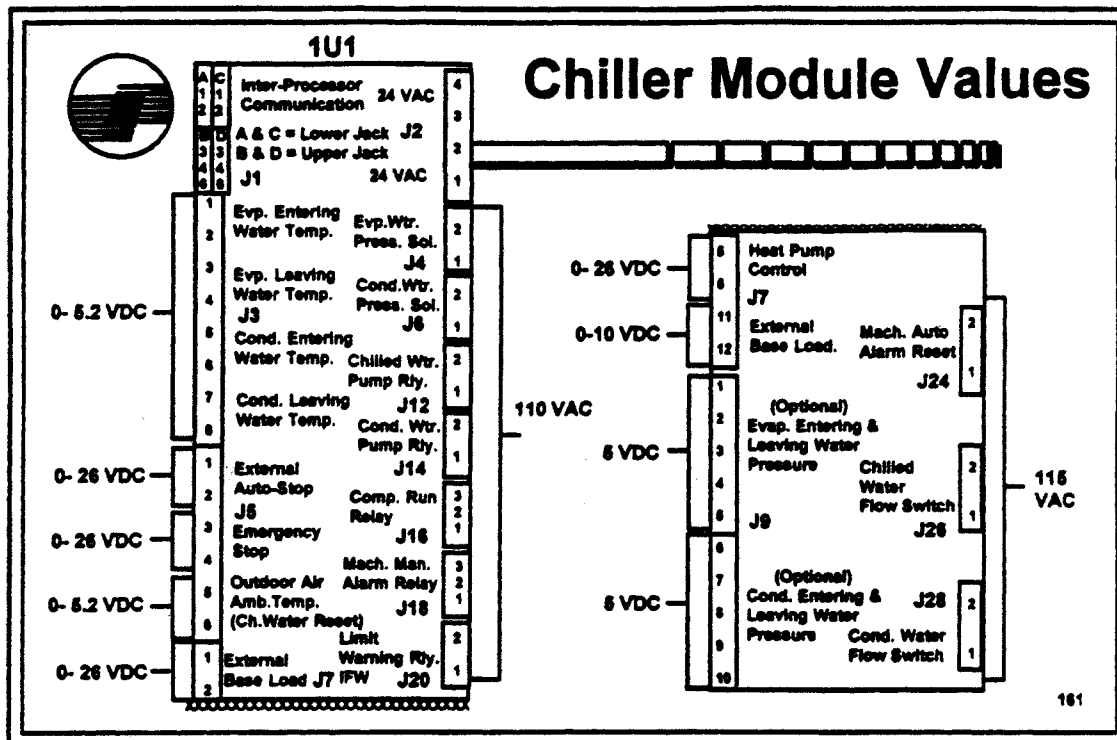

- 1U1 is the “master module”, collecting data, status conditions, diagnostic information, etc. from modules (over the IPC link) from sensors and remote contacts and in turn communicating commands to other modules.
- 1U1 performs leaving water temperature and limit control algorithms, trading off chiller capacity against various “limits” that the chiller may be working against.
- 1U1 checks for valid setpoints and identifies unit type for other modules.
- 1U1 maintains setpoints in non-volatile memory in the event of a power loss.
- Low Voltage (<30VAC) Inputs:
 - 24 VAC; IPC link internal, IPC link purge & starter modules; evap. EWT & LWT; cond. EWT & LWT; external auto stop; emergency stop; ambient air CWR; heat pump control; evap. water delta.P; cond. water delta P
- High Voltage (>30VAC) Inputs:
 - Evap water flow switch; cond. water flow switch
- High Voltage (>30VAC) Outputs:
 - Evap. water pressure solenoid; cond. water pressure solenoid; evap. water pump relay; cond. water pump relay; compressor run relay; MMR alarm relay; MAR alarm relay, limit warning relay

Note: MMR = Machine Manual Reset; MAR = Machine Auto Reset

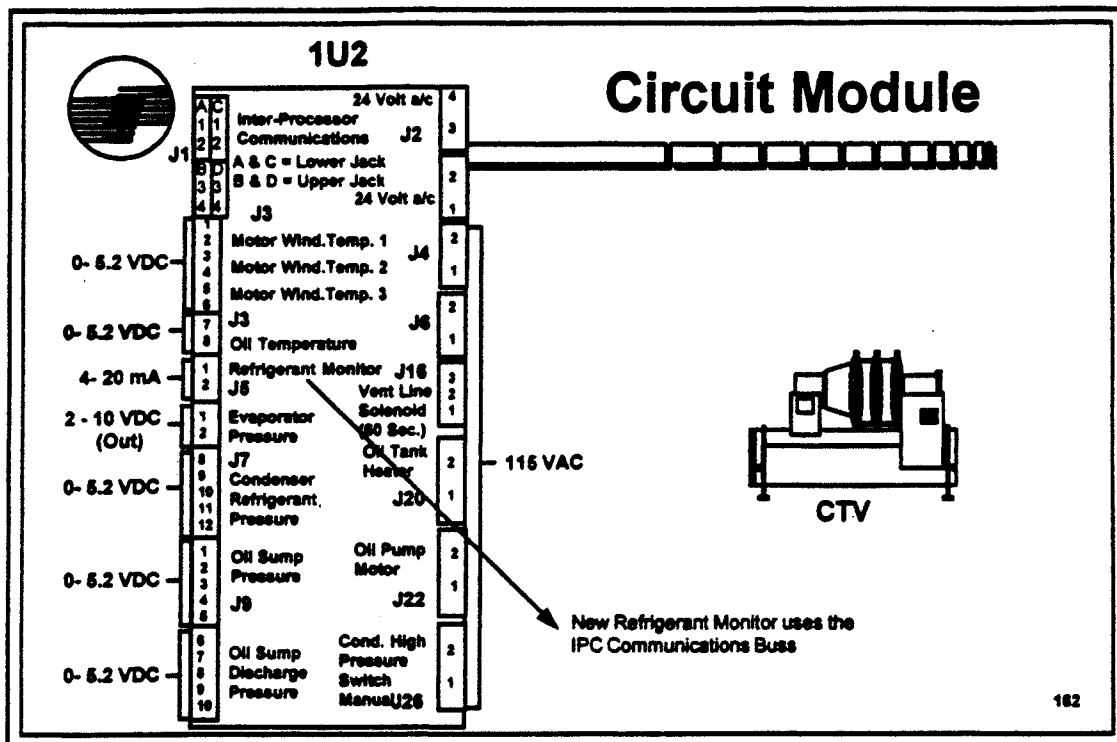

- I/O expander module.
- 1U2 assigned functions associated with compressor motor, lubrication system and refrigerant monitoring.
- Low Voltage (<30VAC) Inputs:
 - 24VAC;
 - IPC link;
 - compressor motor winding temp. sensors 1, 2, 3;
 - oil tank temperature;
 - refrigerant monitor (equipment room ppm level);
 - condenser refrigerant pressure;
 - oil sump pressure;
 - oil pump pressure
- High Voltage, High Amperage (120 VAC) Inputs:
 - High condenser pressure
- High Voltage, High Amperage (120VAC) Outputs:
 - Vent line solenoid valve;
 - oil tank heater;
 - oil pump motor

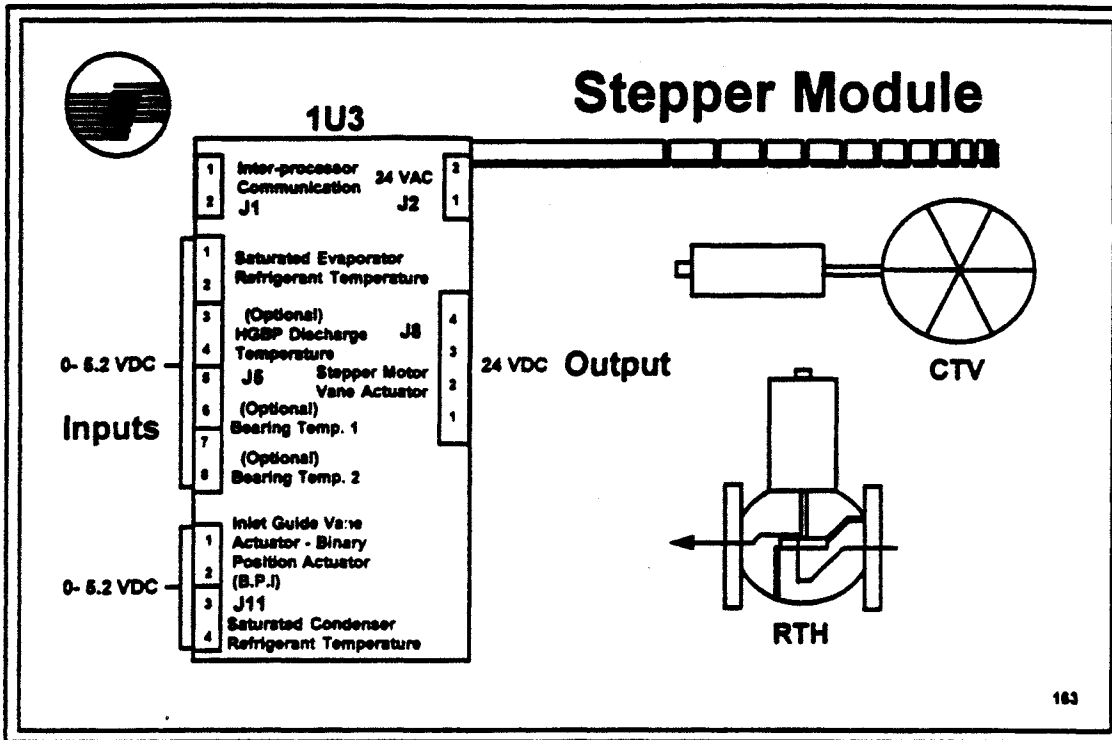

- The main function of 1U3 is to drive the inlet guide vane stepper motor (CTV) or electronic expansion valve (RTHB), along with other functions. It does this in response to signals received from chiller module 1U1.
- Low Voltage (<30VAC) Inputs:
 - 24VAC;
 - IPC link;
 - evaporator saturated refrigerant temperature;
 - compressor discharge temperature (optional);
 - bearing temps, 1 & 2;
 - inlet guide vane actuator position;
 - evaporator saturated refrigerant temperature;
- Low Voltage, High Amperage (<30VAC) Outputs:
 - Vane actuator stepper motor

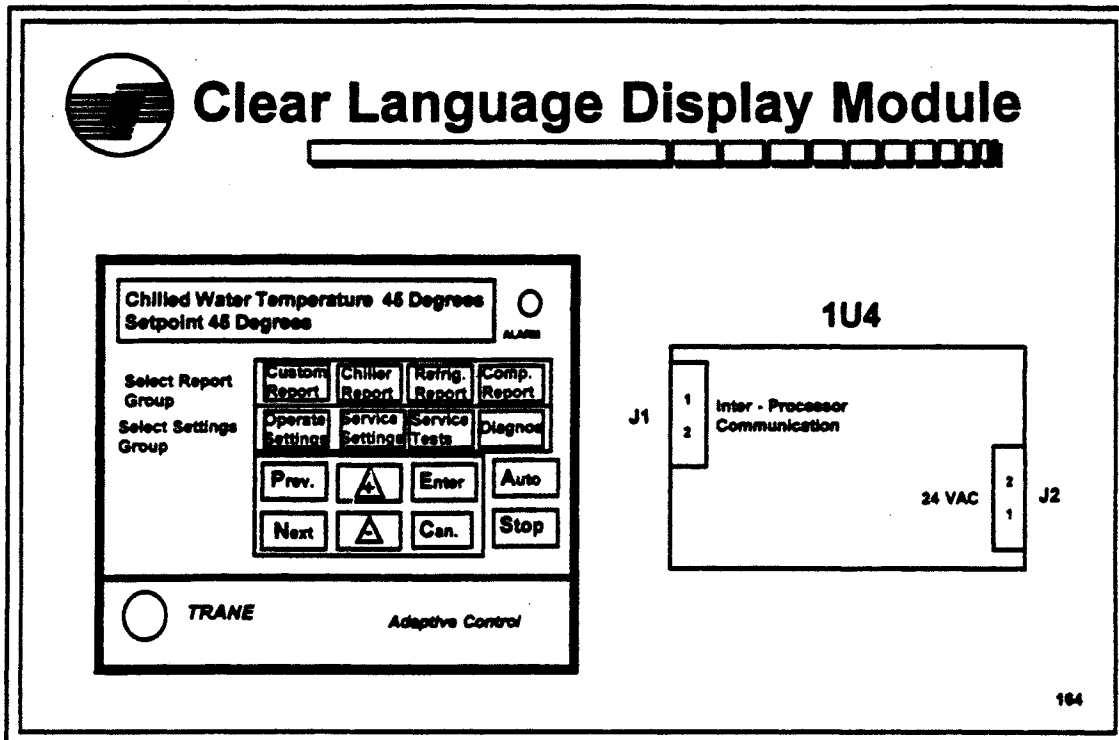

- Referred to in Trane literature as the “CLD” or operator panel.
- In computerese, 1U4 is the “human interface” for the UCP2. It’s the bridge between man and machine. We will not refer to it as the “HP”.
- 1U4 is mounted in the control panel door. It is viewed from the front of the panel.
- Allows operator or service person to monitor system conditions as it displays chiller data, including chiller operating status, setpoints, operating conditions, unit configuration, purge operating conditions, service and diagnostic settings.
- The UCP is accessed by viewing the 2-line LCD display and pressing combinations of the 16 available keys arranged in a 4 X 4 key matrix on the panel.
- Only two low voltage (<30VAC) connections:
 - IPC Link;
 - 24 VAC
- An optional remote display allows chiller operation from as far away as 1,500 feet.

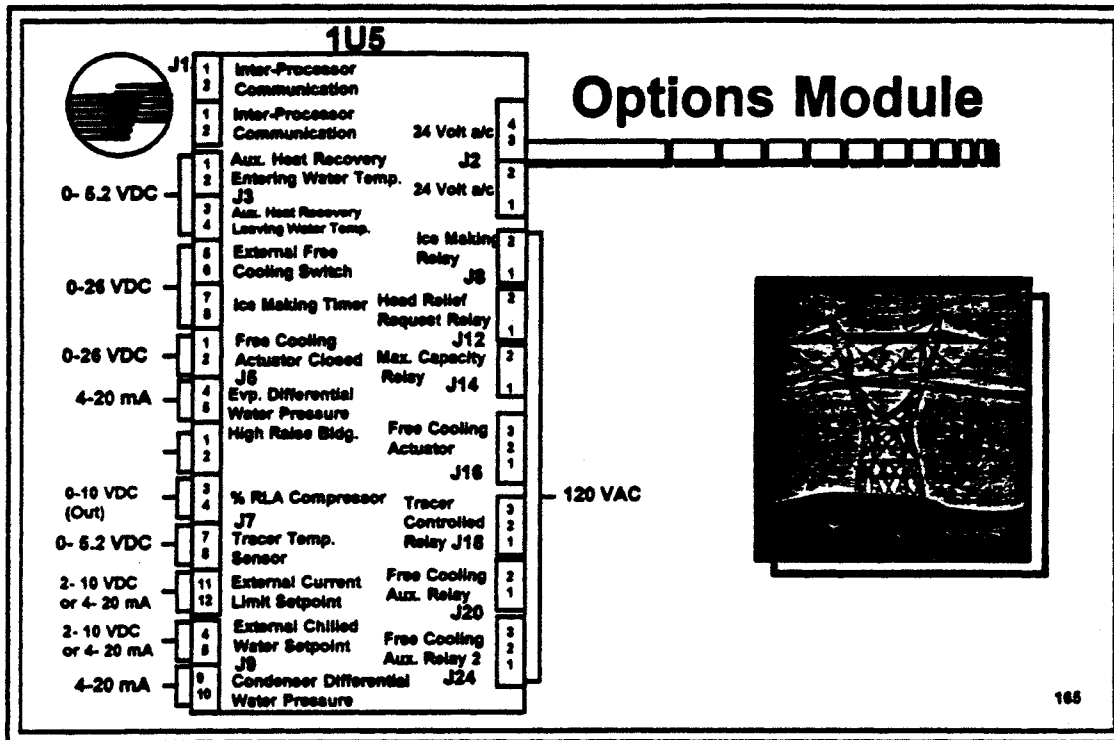

• As its name indicates, 1U5 provides the control or interface requirements for many of the options available with the UCP2.

• **Low Voltage (<30VAC) Outputs:**

Heat recovery actuator;
% RLA compressor

• **High Voltage (>30VAC) Outputs:**

Ice-making relay; head relief request relay;
max. capacity relay;
free cooling actuator relay 1 (liquid line valve) ;
free cooling auxiliary relay;
free cooling actuator relay 2 (gas line valve)

• **Low Voltage (<30VAC) Inputs:**

24VAC;
IPC link;
auxiliary heat recovery EWT;
auxiliary heat recovery LWT
external free cooling control;
external ice-making control;
free cooling actuator closed;
evaporator water delta P;
condenser water delta P;
Tracer temperature;
external current limit;
external chilled water temp. (CWT)



Communication Modules



1U7

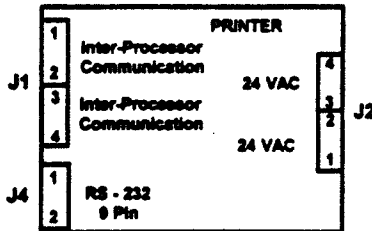

1U7 Printer Module
1U6 & 1U8 Tracer Modules
(Piggyback Board)
1U9 IPC Buffer Module
(Remote CLD Only)

1U6 - 1U8

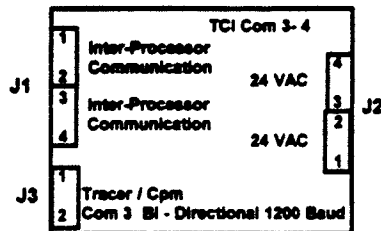

1U9

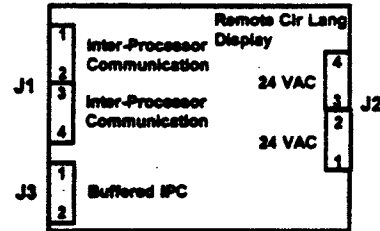

166

- **1U6 - Tracer COM4 Interface (Not Shown):**
Optional module that provides non-isolated, 9600-baud, bi-directional serial communication link to the new Tracer Summit or Tracer i.
- **1U7 - Printer Interface Module:**
Allows a preformatted chiller log to be output at a printer right at the chiller location. Can be programmed using the CLD to print a chiller log on command, at the time of a diagnostic, or on a periodic basis.
- **1U8 - Tracer COM3 Interface:**
Optional module that provides an isolated, 1200-baud, bi-directional serial communication link to a Tracer 100/Tracer i or BAS panels.
- **1U9 - IPC Buffer Module:**
The communication interface between the UCP2 and a Remote CLD. If a remote panel is not used, this module is not required. It just be provided on any chiller (up to 4) talking to a Remote CLD.



Input / Output Module



1U10

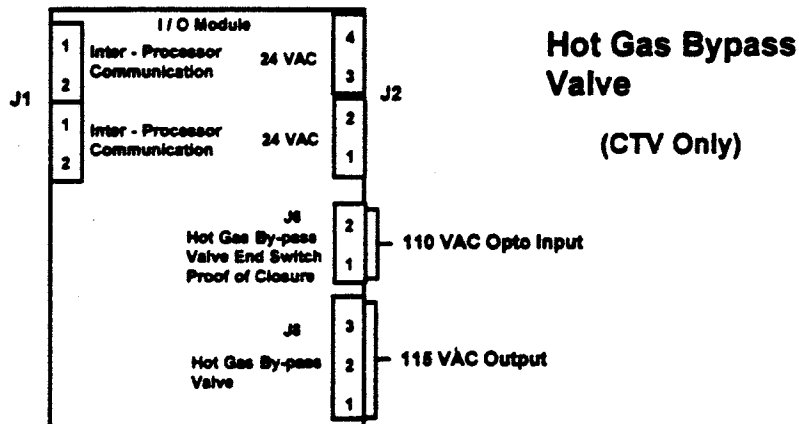

167

- Provided only when chiller is equipped with hot gas bypass (HGBP) option.
- The I/O Module (1U10) operates the hot gas bypass valve on CVHE and CVHF units in response to signals from stepper module 1U3.
- The module also receives input on HGBP valve position from the HGBP valve end switch.
- Low Voltage (<30VAC) Inputs:
 - 0-10 VDC HGBP valve drive signal
- High Voltage (>30VAC) Inputs:
 - 24 V HBPB valve proof-of-closure signal from valve end switch
- High Voltage (>30VAC) Outputs:
 - HGBP open Triac;
 - HGBP close Triac

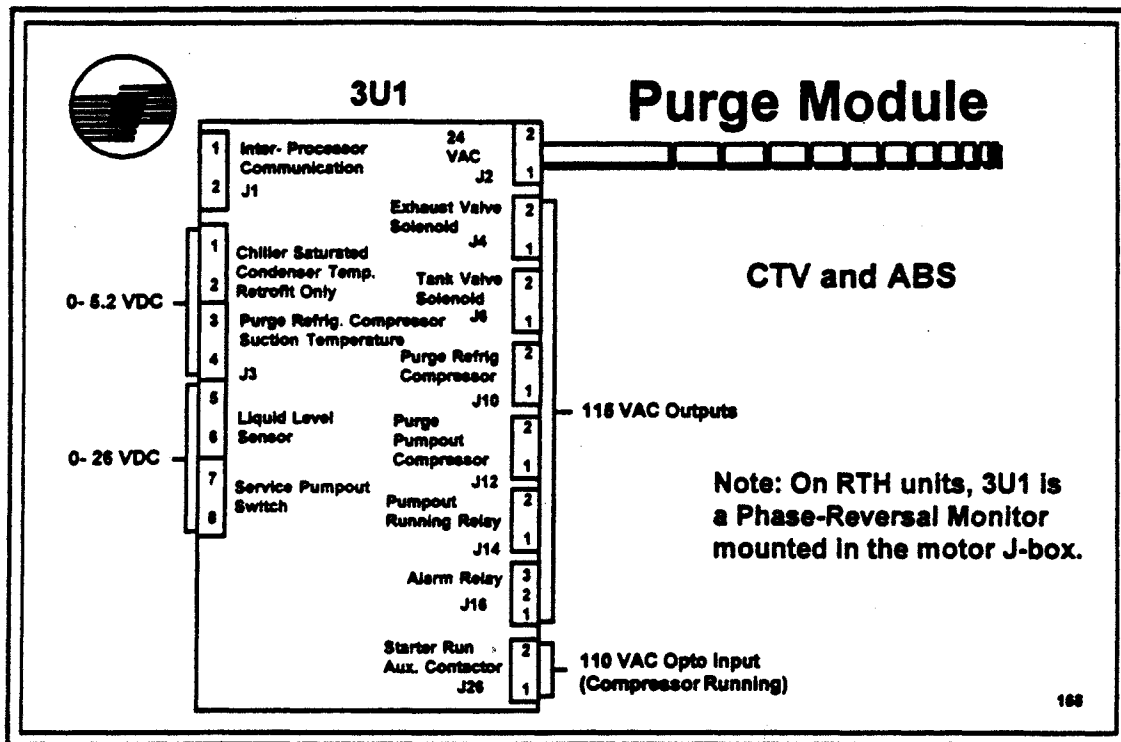

- The purge module (3U1) is provided with the Trane Model PGRC Purifier Purge on CVHE and CVHF chillers. It is located in the purge control panel at the purge. It provides all inputs and outputs for the UCP2 to control purge operation.

- **Low Voltage (<30VAC) Inputs:**

- 24 VAC; IPC link to chiller module;
 - purge refrigeration compressor suction temperature;
 - purge tank liquid level sensor;
 - service pumpout switch

- **High Voltage (>30VAC) Outputs:**

- Exhaust valve solenoid; tank valve solenoid;
 - purge refrigerant compressor;
 - purge pumpout compressor;
 - purge pumpout running (Tracer); purge alarm

- **IMPORTANT:**

Although the RTHB chiller does not have a purge, it does utilize a device designated as 3U1 in certain cases. When the RTHB chiller uses a remote starter, a phase-sequence monitor (3U1) is mounted in the unit-mounted motor terminal junction box. Proper phase-sequencing is critical to prevent reverse compressor rotation which will cause extensive damage almost instantly.

Although the starter module provides this protection, if the starter is remotely mounted, it is possible to cross leads from the starter to the compressor motor.

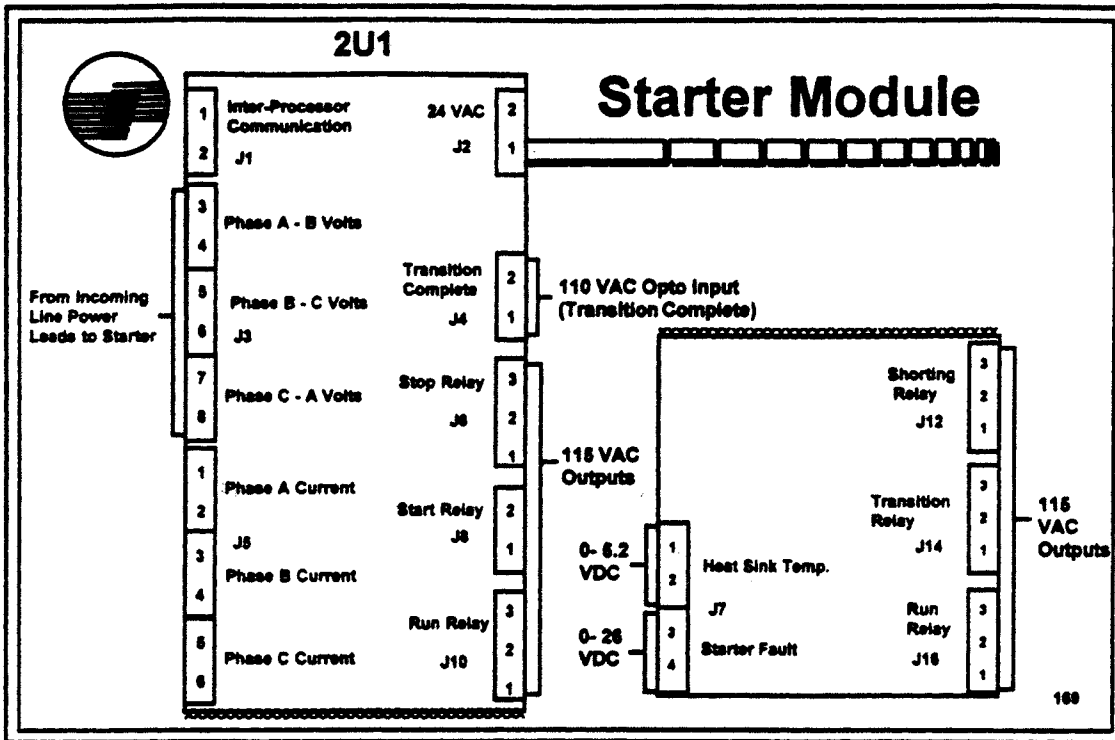

- The starter module (2U1) is present in all Trane-provided starter panels, whether unit-mounted or remote. For CTV's, if no Trane starter is provided and the customer is providing the starter instead, 2U1 is mounted in an extension of the unit control panel. It is still designated as 2U1, however. For RTHB units, 2U1 is always located in the starter panel.
- 2U1 controls the starter when starting, running and stopping compressor motor and provides an interface to all types of starters and AFD's (adjustable frequency drives).
- 2U1 provides compressor motor protection for running overload, phase reversal, phase loss, phase unbalance and momentary power loss.
- Low Voltage (<30VAC) Inputs:
 - 24 VAC; IPC link to chiller module; phase voltages (optional); phase currents; solid-state heat sink temperature (optional); starter driver fault
- Low Voltage (<30VAC) Outputs:
 - Speed signal output (0-10 VDC - optional)
- High Voltage (>30VAC) Inputs:
 - Transition complete (CTV only)
- High Voltage (>30VAC) Outputs:
 - Stop relay; starter relay; run relay; shorting relay; transition relay; shunt trip relay

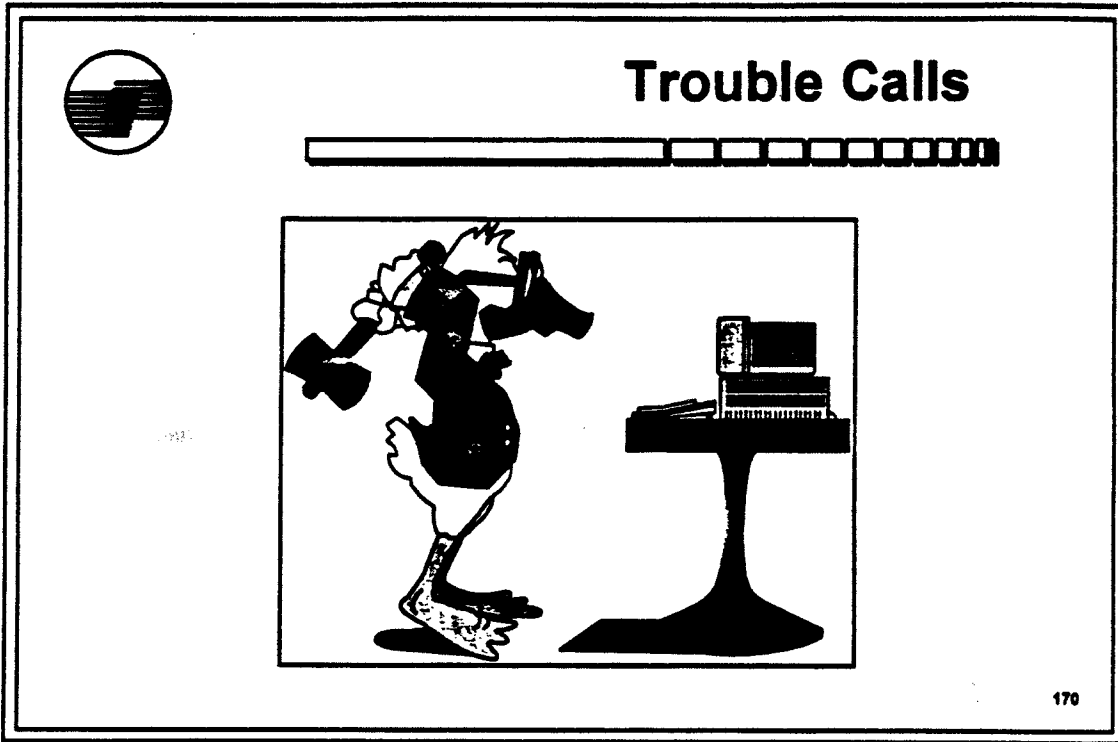

•How many times have you wished you were not a serviceperson? This section details several software and hardware components that might need more explanation.



What Are The Passwords ?



Up to 20 Keystrokes Can Be Entered, Only The Last 6 Count

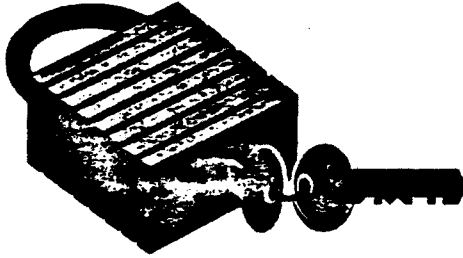

- **Keyboard Lockout ?**
Press Previous And Enter
At The Same Time - To Unlock
- **Field Startup Group Lockout ?**
Press + + - - + + To Unlock
- **Machine Configuration Lockout ?**
Press + - + - + - To Unlock
- **Operator Settings Group Lockout ?**
Press - + - + - + To Unlock
- **Reset Lockout ?**
Software Switch In Diagnostics.
Push Enter After Last Diagnostic Is
Shown

171

•Passwords:

- To keep from getting confused, follow the above mentioned passwords.
- Only the last 6 digits count, you have 14 more that can be used to confuse those who look over your shoulder.
- Keypad and display can also be locked out. Keypad and display lockout can be reset in the Service Settings Group under the Field Start up Menu. (Enable/Disable) This locks out the entire display and keyboard. Panic Stop and Stop does not work. (The password is Previous and Enter at the same time.)
- Menu Settings password can also be locked out. This can be reset the same way as the Keypad and display lockout. (The password to use is -+--+) This allows you to look at the display only.
- Panic Stop and Stop will work.

You can look at this as representing levels of protection:

1. See nothing, Do nothing and the stop button does not work
2. See all reports and some setup screens, and the stop button works.
3. See all, Do all



Grounding

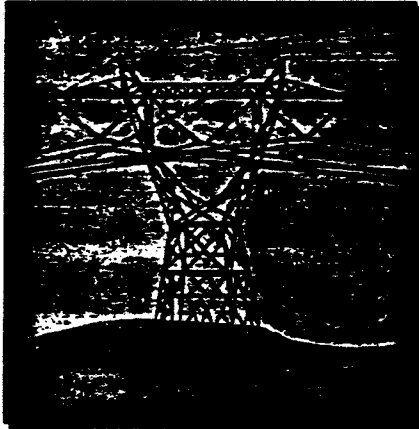

- **All Grounding Shall Be Terminated At The Electrical Panel**
- **Printed Circuit Boards Use Even Numbers For Ground Points And Odd Numbers For Power Points- IPC Only**
- **All Interprocessor Communication Wires Must Be Shielded And attached To Ground**

172

- Grounding is a funny thing. It must be good or your system will not work.
- A ground at one point may not be the same ground as found at another point.
- Always ground at the CTV panel.
- Use large enough copper wire.



Stepper Motor

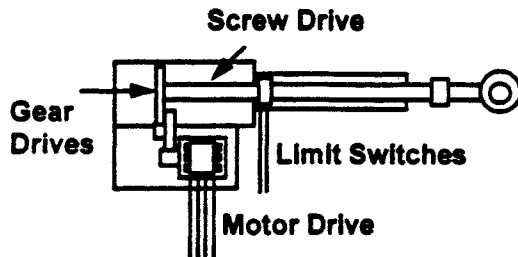

- 4 Pole Motor
- Permanent Magnet Motor
- No Brushes
- Permanent Lub. Ball Bearings
- Totally Enclosed Motor
- Holding Torque Of 60 To 5,330 Oz-In
- Winding Resistance
 - 1.68 Ohms - RTHB,
 - .18 Ohms - CTV, ABS, Horizon Products

See stepper motor hand out in Component Parts section

173

- The stepper motor is a 4 to 8 pole motor. It can have 4 to 8 wires depending on the model used.
- The stepper motor drives a gear train, that spins a worm gear, that drives a screw rod.
- The drive arm closes a switch (Called a BPI-Binary Position Indicator) providing indication that the drive arm is driven open. If not, a diagnostic will be generated calling out the failed stroke length.
- If the indicator has shifted to a closer position to the shaft base compared to the called out stroke length, a diagnostic will appear calling out too short of a drive stroke.
- Nothing calls out that the vanes are open at start up. The unit may cycle on overload.



Inter- Processor Communications

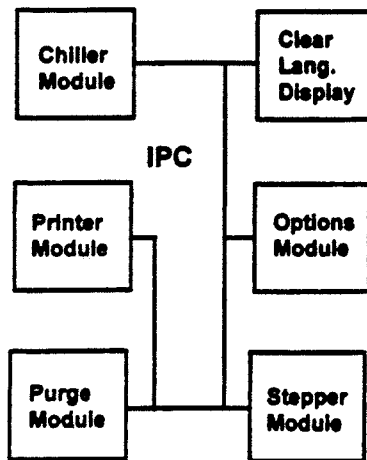

- Reverse Polarity (Even =+, Odd= -)
- Improper Grounding (Control Panel Only)
- Intermittent Connections
- Excess Run Length (1,500 Ft. Maximum)
- Loose Connections
- Corroded Terminals
- Improper Wire Size (Beldon 8760)
- Bad Printed Circuit Boards (Self Checking System)

174

•Inter - Processor Communication cards convert inputs to computer language. All modules communicate to the chiller module. The chiller module contains the CPU.

•When you receive a new CTV, check all wire terminals for tightness and cleanliness.

•Check all P.C. board mountings for tightness.



Momentary Power Loss Protection

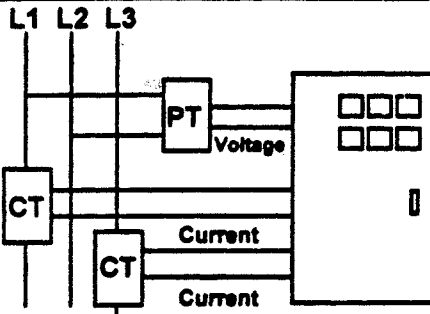
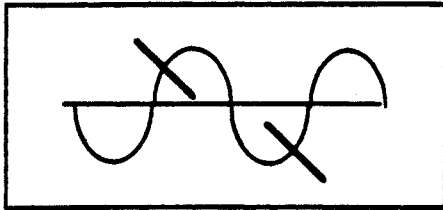

- 20 Times Rated Torque
- Rotor Bar And Stator Failures
- Impeller And Shaft Key Way Damage
- Starter Contactor Damage
- Current And Voltage Always Wants To Be In Phase
- Will Detect Momentary Power Loss In 2- 3 Electrical Cycles And Shutdown In 6 Cycles
- 60 Cycles/Sec = 1/30, 1/10 Of A Second
- As the motor turns into a generator, the UCP sees it and trips out

175

- When motor power is lost for a short period of time (1 Second) and restarts, the motor (The motor is several coils of wire) turns into a generator. When the power restarts, the motor is out of phase and will jump into phase.
- This power jump is equal to 20 x Rated torque. Things will break.
- Impellers Break
- Key Ways Tumble
- Motor Tie Wraps Break
- Motor Windings Become Loose



Starting Overcurrent Protection

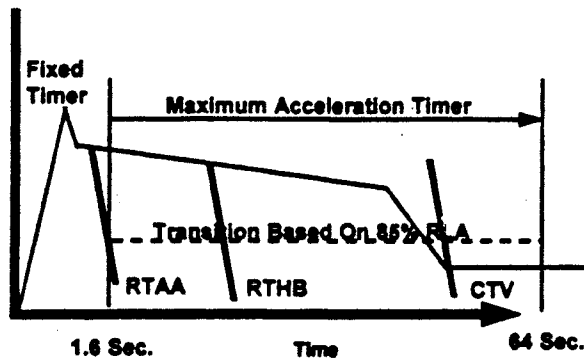

	Timer 1	Timer 2
Y - Delta	= 27 Sec.	*228
Auto - Tran.	= 16 Sec.	*239
Pri. - React.	= 16 Sec.	*239
Across Line	= 6 Sec.	*249
Sol. St. Start	= 20 Sec.	*235
Vari. Speed Dr.	= 12 Sec.	*243

Choice: Shutdown or Transition

176

- Normal transition time will be based on the type of starter used and the motor current decreasing to 85 % RLA. At this time the UCM shall time out 1-2 seconds and then transition.

- The exception to this rule is a fixed transition time of 1.6 seconds; The starter shall never be transitioned at less than 1.6 seconds from start.

- If at 1.6 seconds the current is less than 85% RLA the UCM shall transition immediately.

- If the starter is not transitioned within the maximum transition time setpoint there shall be two possible outcomes based on a second setting.

1. The starting sequence is aborted, the starter is de-energized, and a latching diagnostic(MMR) is generated.

2. The starter is transitioned and a (IFW) is generated.



Running Overcurrent Protection

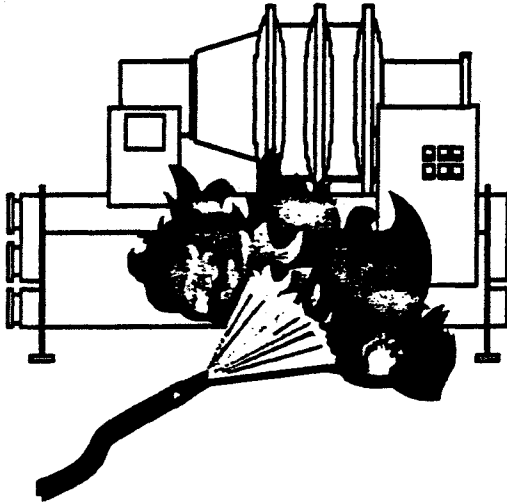

- Overload Must Hold At 102%RLA
- Overload Must Trip At 112 % RLA After 20 Seconds + - 3 Sec.
- Overload Must Trip At 140% RLA After 1.5 Seconds
- Based on Highest Phase Current

177

- Current Overload Protection - The UCM shall continuously monitor compressor current to provide running overcurrent and locked rotor protection. Overcurrent protection shall be based on the phase with the highest current.
- When reached, it shall trigger a manually resettable diagnostic shutting down the affected compressor and associated refrigerant circuit when the current exceeds a specified time-trip curve.
- The compressor overload shall be based on unit RLA.
- Older CVHE controls had a must trip point of 107% of RLA for 20 seconds. This control is the same.



Running Overcurrent Protection

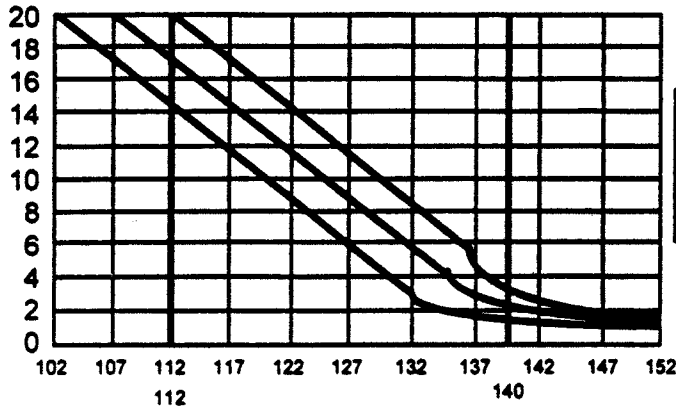

Dark Red = Minimum Trip Time
Medium Red = Nominal Trip Time
Light Red = Maximum Trip Time



Over Current Vane Control



UCP 1

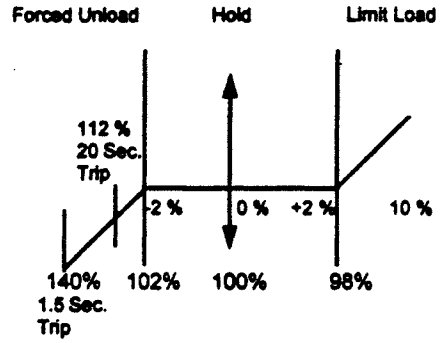
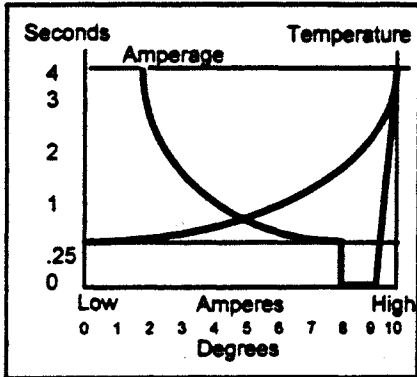

179



Phase Unbalance

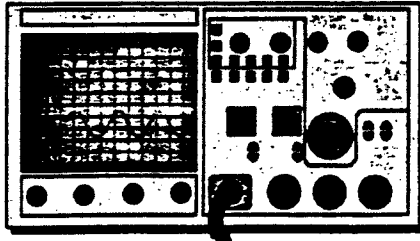

- Formula Is:
 $100X \text{ Sum of Dev. of Each Phase Current To The Average} / \text{By } 2X \text{ Avr.}$

- Measured - 200,225,250 A

- Average Is 225 Amps

- Difference Is $50 \times 100 = 5000 / 500 = 10\%$ Unbalance

- At 25% / 30% Unbalance The UCP Will Trip But The Unit Will Unload To Try To Maintain Operation

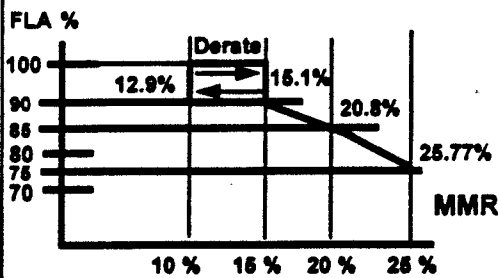

180

- An imbalance in phase currents causes motor windings to heat up.
- Imbalance may be caused by the incoming power or the motor.
- Ultimate phase unbalance trip point shall be 24 to 25 % within 5 to 30 seconds. Average is 15 seconds.
- At 100% RLA and 15% unbalance the CVHE will close it's vanes to a RLA rating of 90%
- As the unbalance increases to 25% the vanes will reduce to a rating of 75%

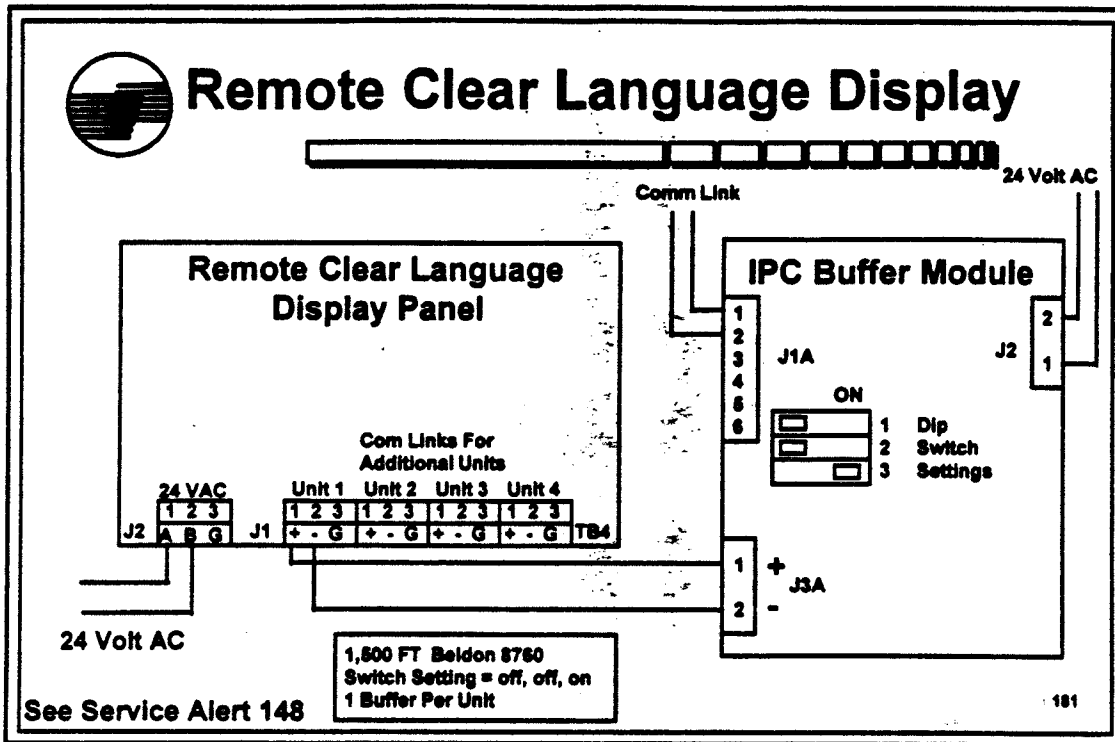

- Remote CLD can support up to 4 units
- Remote CLD units can see CVHE, F-ABS-RTHA, B all at the same time
- Remote CLD will automatically change its readouts to whatever equipment it is directed to see.
- Each unit attached to a Remote CLD must have its own twisted pair wire
- Each IPC buffer has dip switches that must be addressed.
- Most functions can be addressed at the remote CLD. A local STOP takes precedence over all remote commands.



Sensor Values

RTH- CTV- ABS

182

- The next series of slides highlight the correct sensors by part number and the values they use. We also call out in the script where the sensors are located.



Motor Winding Temp. Sensors



- * 0 F. = 61.9110 Ohms = .2915 Volts DC
- * +40 F. = 68.6926 Ohms = .3214 Volts DC
- * +80 F. = 75.9363 Ohms = .3529 Volts DC
- * +120 F. = 83.6124 Ohms = .3858 Volts DC
- * +160 F. = 91.6955 Ohms = .4200 Volts DC
- * +200 F. = 100.1604 Ohms = .4552 Volts DC
- * +240 F. = 108.9817 Ohms = .4914 Volts DC
- * +265 F. = 114.6648 Ohms = .5143 Volts DC - 2 Sec. Trip
- * +280 F. = 118.1342 Ohms = .5283 Volts DC

75 Ohm RTD Resistance Vs Temperature

183

•This sensor is located in the compressor motor. There are 3 used and the control looks for an unbalance between each sensor. If one sensor reads hot, the system lockout.

•A replacement RTD or resistor can be used to fool the control. Use an 80 Ohm 1/4 or 1/2 watt wire wound resistor for this purpose.



Motor Temperature Sensors

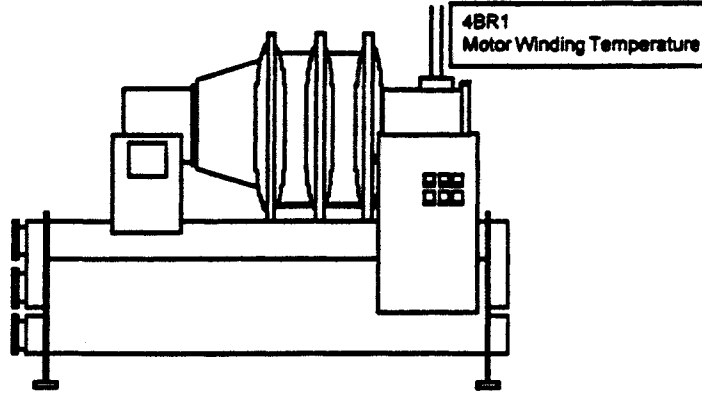

184



CTV-RTH Sat. Evap. Rfgt. Temp.



- * -10 F. = 121326 Ohms = 3.7765 Volts DC
- * 0 F. = 87511 Ohms = 3.457 Volts DC
- * +10 F. = 63769 Ohms = 3.1065 Volts DC
- * +20 F. = 46919 Ohms = 2.7385 Volts DC
- * +30 F. = 34839 Ohms = 2.3705 Volts DC
- * +32 F. = 32861 Ohms = 2.2985 Volts DC
6 F. Differential from CWS, SP Moves Up
- * +40 F. = 26220 Ohms = 2.0235 Volts DC
- * +50 F. = 19955 Ohms = 1.7065 Volts DC
- * +60 F. = 15333 Ohms = 1.4245 Volts DC

X13790159 - 02

185

•This sensor can be used to obtain information to compute APPROACH and FREEZE LIMIT.

•There is a 6 degree F. deadband between the freeze limit and the set point. If the freeze limit is set at 32 degrees F. the setpoint would be 38 degrees F.



Sat.Evap. Refrigerant Temp.



X13790159-02

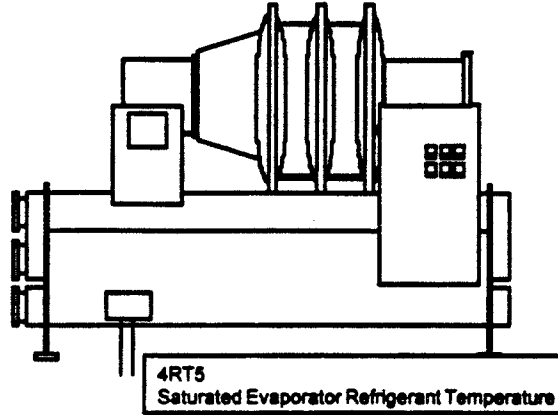

186

- The location for this control is in the bottom of the chiller.



CTV-RTH-ABS Outdoor Air Sensor



* -10 F. =	121326	Ohms =	4.7210	Volts DC
* 0 F. =	87511	Ohms =	4.6235	Volts DC
* +20 F. =	46919	Ohms =	4.3440	Volts DC
* +40 F. =	26220	Ohms =	3.9380	Volts DC
* +60 F. =	15333	Ohms =	3.4225	Volts DC
* +80 F. =	92975	Ohms =	2.8415	Volts DC
* +100 F. =	5824	Ohms =	2.2615	Volts DC
* +120 F. =	3756	Ohms =	1.7400	Volts DC
* +140 F. =	2493	Ohms =	1.3095	Volts DC

X13790159 - 09

187

- The outdoor air sensor should be mounted on the North side of the building. It should also be protected from the weather.
- This sensor is typically used for reset control.

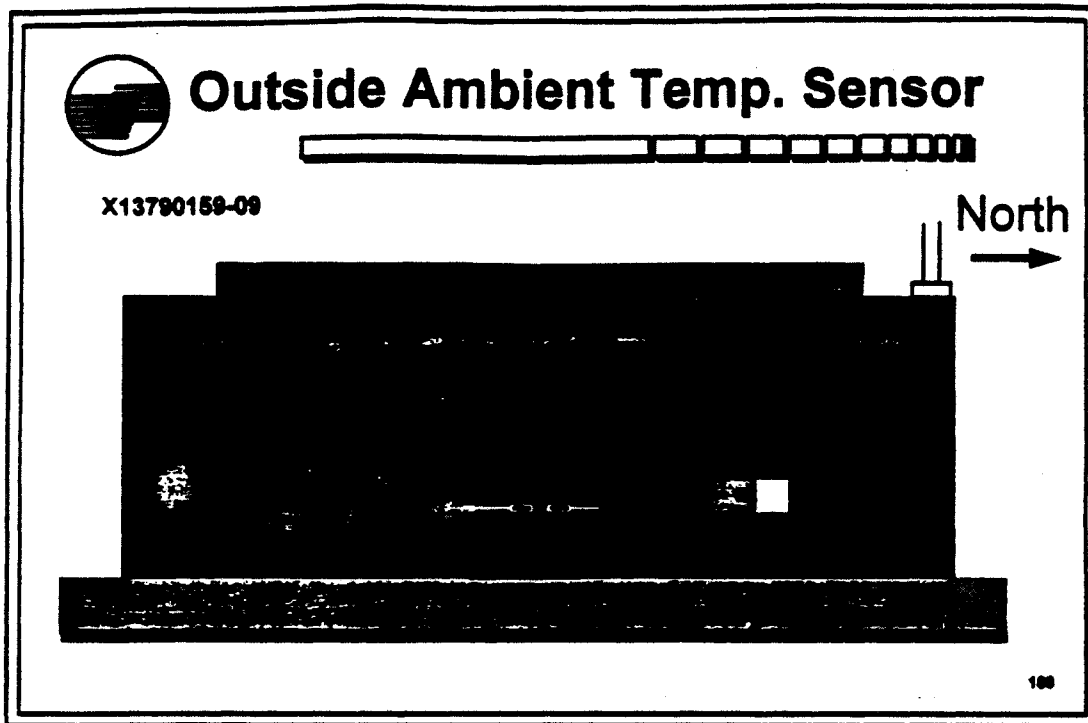

•When used, protection is of utmost importance. Protection from the Sun, Rain and Snow.



Evap. Ent. And Leav. Water Temp. CTV - RTH - ABS



- * +15 F. = 54635 Ohms = 3.4200 Volts DC
- * +30 F. = 34839 Ohms = 2.9035 Volts DC
- * +45 F. = 22846 Ohms = 2.3830 Volts DC
- * +60 F. = 15333 Ohms = 1.8840 Volts DC
- * +75 F. = 10502 Ohms = 1.4790 Volts DC
- * +90 F. = 7330 Ohms = 1.1740 Volts DC
- * +105 F. = 5206 Ohms = .8630 Volts DC
- * +120 F. = 3757 Ohms = .6545 Volts DC

X13790159 - 04

189

•These water sensors provide a Delta " T " reading. Compared to the specifications, troubleshooting is possible.

•This reading is used for computing APPROACH.



Evap. Ent. and Leav. Water Temp.



X13790159-04

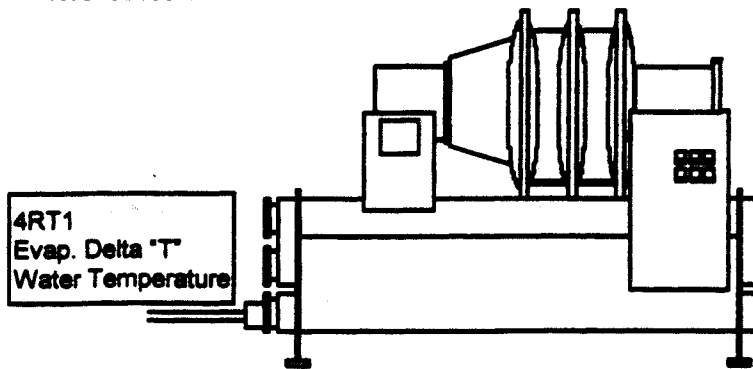

190

•These sensors are mounted on the chiller nipples the flange is mounted to.



Purge Comp. Suction Temp. Sensor



- * 0 F. = 87511 Ohms = 3.8755 Volts DC
- * +10 F. = 63769 Ohms = 3.5800 Volts DC
- * +20 F. = 46919 Ohms = 3.2525 Volts DC
- * +30 F. = 34839 Ohms = 2.9035 Volts DC
- * +40 F. = 26220 Ohms = 2.5545 Volts DC
- * +50 F. = 19955 Ohms = 2.2155 Volts DC
- * +60 F. = 15333 Ohms = 1.8990 Volts DC
- * +70 F. = 11888 Ohms = 1.6105 Volts DC
- * +79 F. = 9525 Ohms = 1.3795 Volts DC

X13790054 - 03

191

•This sensor tells the purge exhaust compressor and the exhaust solenoids to operate. The working range is from 18 to 22 degrees F.



Purge Comp. Suction Temp.



X13790054-03

3RT2
Purge Comp.
Suction Temp.

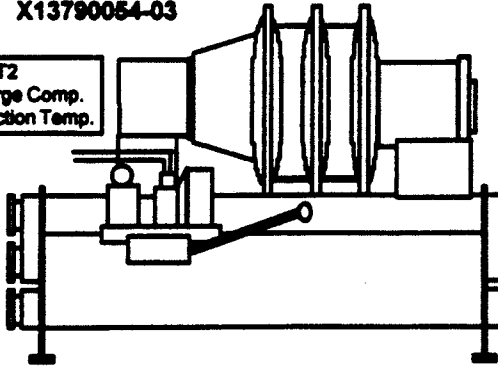

192

- This sensor is located on the purge refrigerant circuit suction pipe line. This sensor like the others should be insulated.



Cond. Ent / Lvng. Wat. Temp. Sensor Ht. Recov. Ent / Lvng Wat. T. Sensor

- * +60 F. = 15333 Ohms = 3.4225 Volts DC
- * +70 F. = 11888 Ohms = 3.1365 Volts DC
- * +80 F. = 9297 Ohms = 2.8420 Volts DC
- * +90 F. = 7330 Ohms = 2.5475 Volts DC
- * +100 F. = 5824 Ohms = 2.2615 Volts DC
- * +110 F. = 4661 Ohms = 1.9905 Volts DC
- * +120 F. = 3757 Ohms = 1.7400 Volts DC
- * +130 F. = 3050 Ohms = 1.5125 Volts DC
- * +140 F. = 2493 Ohms = 1.3100 Volts DC

X13790159 - 04

183

•This sensor is used to obtain approach. This also is used for heat recovery units.

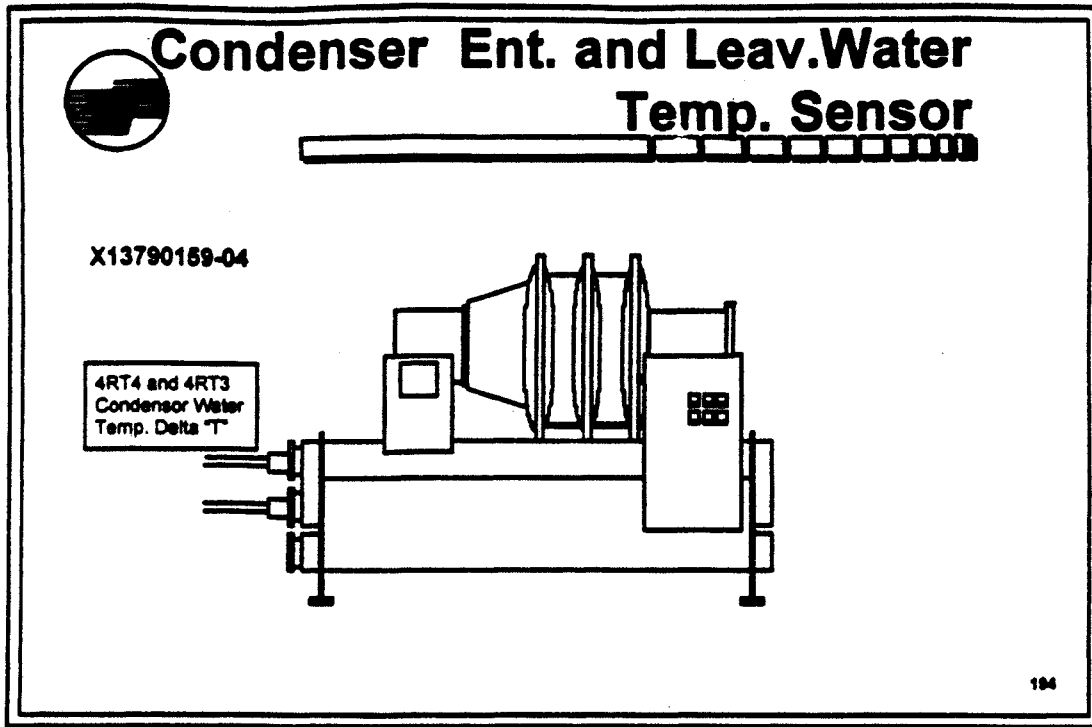

•These sensors are located on the nipple next to the flange.



Sat. Cond. Refg . Temp. CTV - RTH - ABS



- * +15 F. = 54635 Ohms = 4.4255 Volts DC
- * +20 F. = 46919 Ohms = 4.3440 Volts DC
- * +40 F. = 26220 Ohms = 3.9380 Volts DC
- * +60 F. = 15333 Ohms = 3.4225 Volts DC
- * +80 F. = 9297 Ohms = 2.8420 Volts DC
- * +100 F. = 5824 Ohms = 2.2615 Volts DC
- * +120 F. = 3757 Ohms = 1.7400 Volts DC
- * +140 F. = 2493 Ohms = 1.3100 Volts DC

X13790159 - 01

195

- This sensor is used to obtain a pressure temperature relationship. Pressure transducers are not standard.
- This sensor provides a way to compute condenser lift.

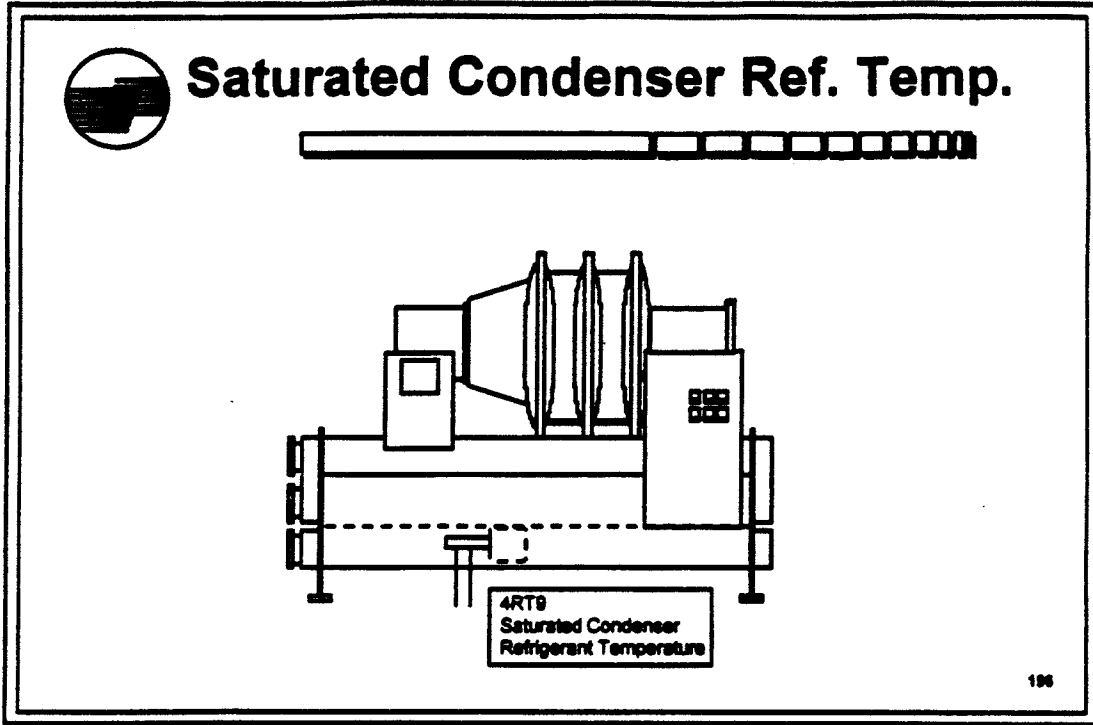

•This sensor is located at the bottom of the condenser.



Absorber Units



- +15 F. = 54635 Ohms = 4.4255 Volts DC
- +20 F. = 46919 Ohms = 4.3440 Volts DC
- +40 F. = 26220 Ohms = 3.9380 Volts DC
- +60 F. = 15333 Ohms = 3.4225 Volts DC
- +80 F. = 9297 Ohms = 2.8420 Volts DC
- +100 F. = 5824 Ohms = 2.2615 Volts DC
- +120 F. = 3757 Ohms = 1.7400 Volts DC
- +140 F. = 2493 Ohms = 1.3100 Volts DC
- Entering Water Temp. Sen.
- Sat. Evap. Rfgt. Temp. Sen.
- Dilute Solution Leaving Absorber Temperature Sen.
- Intermediate Sat. Absorber Spray Temperature Sen.

X13790159 - 01

197



Absorber Units - Strong Solution Lvng Lo-Temp-Gen. Temp. Sen.

- * **LTG = Single Stage Unit - Leaving Low Temperature Concentrator (Gen) Sensor**
- * **+40 F. = 101.7629 Ohms = .4648 Volts DC**
- * **+80 F. = 110.5429 Ohms = .5007 Volts DC**
- * **+120 F. = 119.2652 Ohms = .5358 Volts DC**
- * **+160 F. = 127.9296 Ohms = .5701 Volts DC**
- * **+200 F. = 136.5363 Ohms = .6036 Volts DC**
- * **+240 F. = 145.0852 Ohms = .6365 Volts DC**
- * **+280 F. = 153.5764 Ohms = .6686 Volts DC**
- * **+320 F. = 162.0097 Ohms = .7000 Volts DC**

X13791064 - 01

198



Absorber Units



- -40 F. = 83.9633 Ohms = .3900 Volts DC
- 0 F. = 92.8971 Ohms = .4277 Volts DC
- +50 F. = 103.9789 Ohms = .4736 Volts DC
- +100 F. = 114.9699 Ohms = .5182 Volts DC
- +150 F. = 125.8703 Ohms = .5616 Volts DC
- +200 F. = 136.6801 Ohms = .6038 Volts DC
- +250 F. = 147.3993 Ohms = .6448 Volts DC
- +300 F. = 158.0280 Ohms = .6848 Volts DC
- +350 F. = 168.5660 Ohms = .7237 Volts DC
- +400 F. = 179.0135 Ohms = .7616 Volts DC
- +450 F. = 189.3704 Ohms = .7985 Volts DC
- Steam Cond Lvng LTG Sen.
- Steam Cond Lvng HTG Sen.
- Gen. Lvng Hot Water Sensor
- Gen. Ent. Hot Water Sensor
- Dilute Sol. Lvng LTHX Sen.
- Interstage Sol. Lvng HTG Sen.
- Dilute Sol. Ent. HTG Sensor
- Dilute Sol. Lvng HTHX Sen.
- Interstage Sol.Temp Ent.LTG Temp.

2 Stage ABS

X13790158 - 03

100

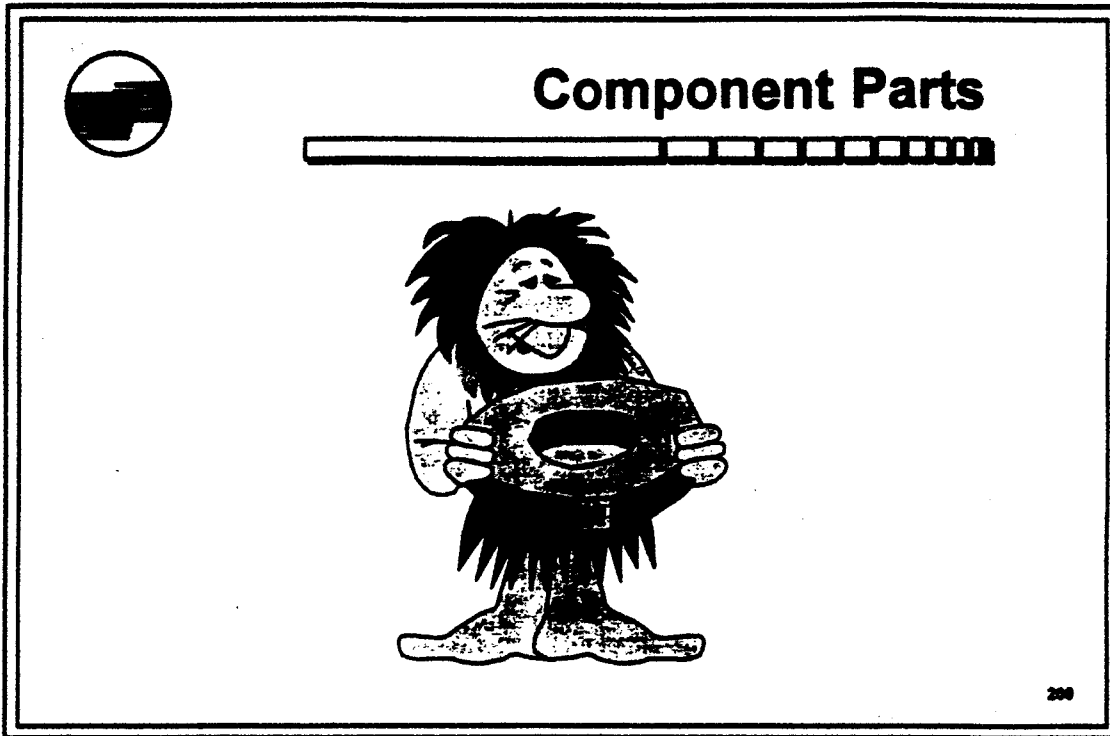

- This series looks at component parts.
- More detailed information is provided.



Stepper Motor



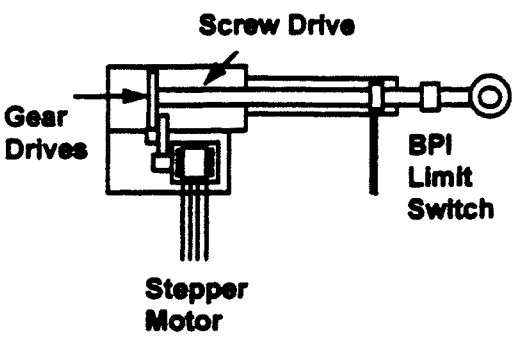

- Load Range = 2,000 Lbs.
- Drive Steps Up To 60,000 Increments Of 100 Steps
- Open - Closed Stops Adj. From 0 - 100 %
- Driven Closed On Startup To Calibrate Software
- BPI Feedback Switch
- 24 Volt DC Drive Motor (Watch Out For Wiring)
- Wire 1 To 4 > Winding 1
- Wire 2 To 1 >
- Wire 3 To 5 > Winding 2
- Wire 4 To 3 >

201

•The stepper motor is a 24 volt, high amperage class 1 electrical system. It can HURT you. This is not like a thermostat circuit (Low voltage/Low amperage), it is a motor drive circuit.

•The stepper motor can drive up to 60,000 steps, but depending on the drive action will drive less.

•CVHE = 50,000 Steps

•RTHB = 2,760 Steps > 255 to 450 Tons
2,040 Steps > 130 to 215 Tons

•RTAA = 1,250 Steps > 130 to 400 Tons

•The Binary Position Indicator (BPI) can be adjustable. The magnet is in the shaft and the receiver is mounted outside the motor. The receiver will register that the vanes or valves are open or closed.

•The receiver will also call out BPI Not found and BPI Too early. Both are IFW warnings.

•The Shaft is a gear driven shaft.



Stepper Motor

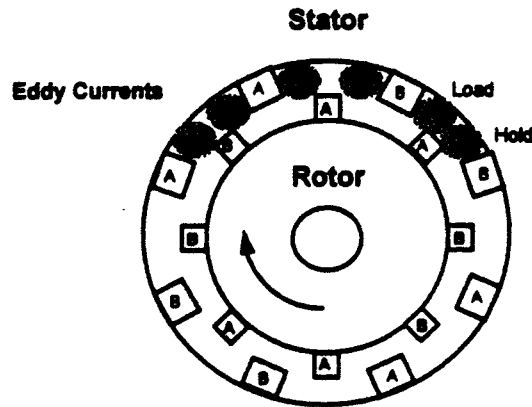

1 Step = .00011" Linear Movement

1.8 Degrees Per Step or Pulse

$80,000 \times .00011 = 8.8"$

$360 : 1.8 = 200$ Steps Per Rotation Of Shaft

Default
 $100 : 80,000 = .125\%$
Of Total Throw (8.8 ")
 $.125 \times 8.8 = .0093$ Inches Per 100 Steps

202

- The stepper motor has power applied to both the drive windings and the hold windings. It's like the old Proportional Bridge Circuit motor, but it is better.
- The CVHE requires the most movement. Approximately 6 inches.
- The RTAA requires 3/8 inches from full open to full close.
- Eddy currents surround the motor poles one is push and the other is pull. When both are the same, you have a dynamic brake system. The rotor will hold and not move.

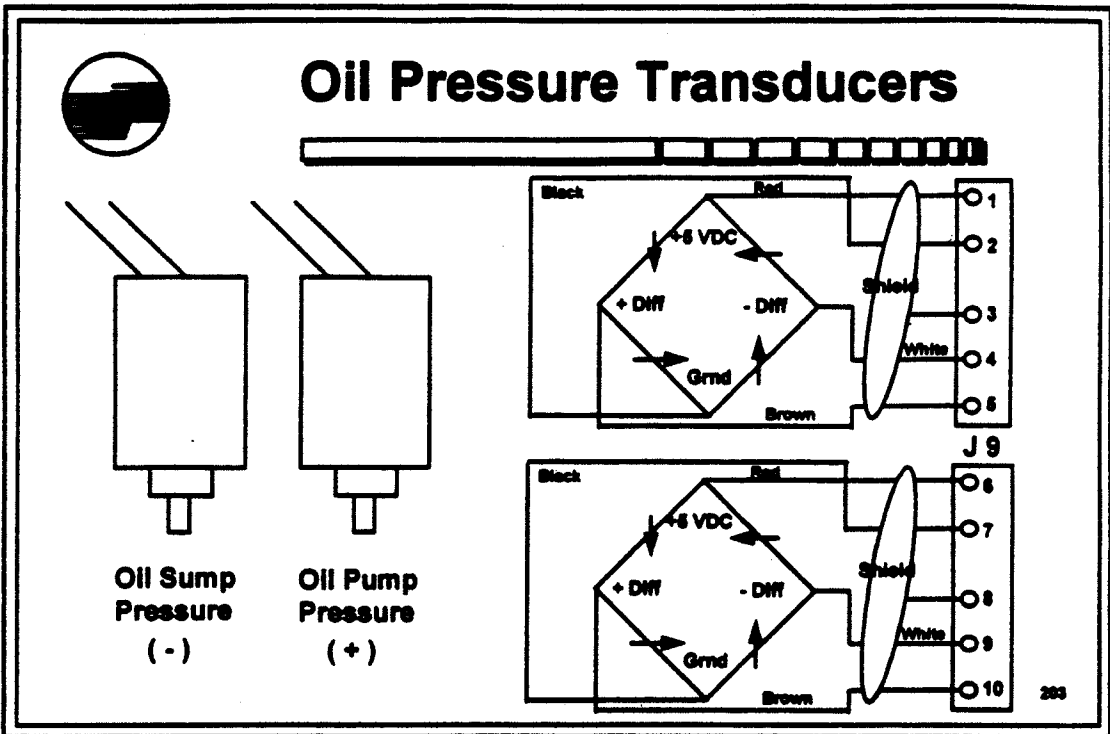

- Pressure transducers have a diaphragm that can rupture. Care must be taken with selection and placement.
- The transducer works on the balanced bridge circuit.
- The applied voltage is 5 Volts D/C
- Shield the wires to the panel only.



Oil Pressure Transducers



No More Gauges

**Normal Delta " P " Oil Pressure = 12 To 18 Psi
Mounted Downstream Of The Oil Regulator
Minimum Running Oil Pressure = 9 Psid
3 Minute Compressor Time Delay At Startup (Prelube)
5 Minute Time delay after Compressor Off Cycle
Transducers are recalibrated to 0 Psid if a differential of more
than 3 PSIG exists**

**(Warning) A Deep Vacuum Will Effect The Transducer
And Recalibration Is Required**

204

•Describe what is called out above.



Oil Measurement Procedure



Measure Oil Sump Pressure = 15 inches Hg
Convert To Pressure = Divide The Oil Sump Pressure
By 2.036 (15 Inches Hg : 2.036 = 7.367 Psi)
Measure Oil Pump Pressure = 12 Psi
Add 12 Psi And 7.367 Psi = 19.367 Psid (Differential)

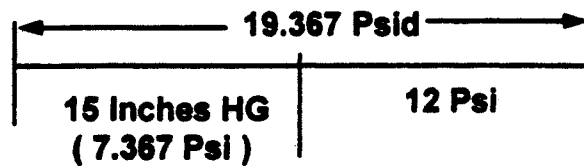

205

- Describe the importance of properly computing net oil pressure.
- To convert 1 Inch Hg to pressure, divide by 2.036 = .4912 PSI
- .4912 X 15 Inches Hg. = 7.367 PSI - Pressure
- Differential Pressure = Negative Pressure Plus Positive Pressure



Current Transformers



Induction Transformers

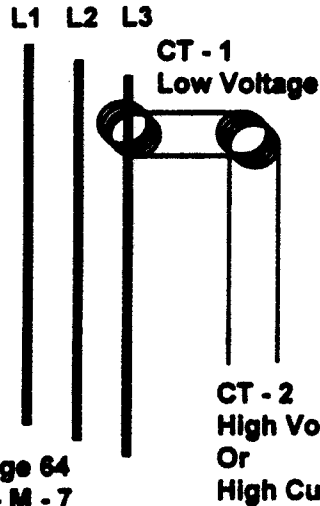

See Page 64
CVHE - M - 7

Table #1 (Below 600 Volts)

CT - Factor = (Motor RLA : CT Rating X 100)

300 Amps : 400 Amps = .75

.75 X 100 = 75 CT Factor

75 = Current Overload Setting #1 (10)

Current Overload Setting #2 (245)

Table #2 (Above 600 Volts)

CT - Factor = (Motor RLA : CT Rating X 139)

(#1 = 04, #2 = 251)

Warning, Watch Out For CT - 2
Primary Turn Amounts

206

- Setting the values of the CT's can be confusing. The values used for setting 1 and 2 are additive to 255. Using "0" as a base 255 turns into 256. This is computer binary logic.
- The computation for Overload setting 1 is shown above. What ever Setting 1 is, setting 2 is the balance of that number and setting 2.
- Use table 1 if the amperage is below 1,000.
- Use table 2 if the amperage is above 1,000.



Current Transformers



Binary Numbering System

Number 10 = (2) 000 000 010
(8) 000 001 000
(10) 000 001 010

Number 37 = (32) 000 100 000
(4) 000 000 100
(1) 000 000 001
(37) 000 100 101

Powers of 2 (Binary System)

2 to the 0 power = 1	000 000 001
2 to the 1 power = 2	000 000 010
2 to the 2 power = 4	000 000 100
2 to the 3 power = 8	000 001 000
2 to the 4 power = 16	000 010 000
2 to the 5 power = 32	000 100 000
2 to the 6 power = 64	001 000 000
2 to the 7 power = 128	010 000 000
2 to the 8 power = 256	100 000 000

207



Restart Inhibit Timing



If The Motor Is Cool (Below 165 Deg.F.) RI Timer Is Automatically Set At 30 Seconds Regardless of The RI Timer
If The Motor Is Warm (Above 165 Deg.F.) RI Timer Is Automatically Set At 15 Min Plus Any RI Time Value

The Maximum RI Timer Value Is 60 Minutes, But Is Adjustable From 25 To 60 Minutes Via The BT Timer
The BT Timer Is Based on System Tons And Hz Values
The BT Timer Is Defaulted To 25 Min

The Objective Is To Keep The Motor Cool And Off Time To The Minimum

See Page 78 CVHE - M - 7

208

- The RI timer is another magic device that has a mind of its own. Timing will change automatically based on temperature, and setpoint time.
- If the motor is below 165 Degrees F. the RI timer delays the motor start 30 seconds.
- If the motor is above 165 Degrees F. the RI timer is off for a minimum of 15 minutes to 60 minutes if you set the rate to maximum and the unit is a 1600 ton unit.
- If the unit is a small one the minimum time (Above 165 Degrees) is from 15 minutes to 25 minutes.
- The RI time is a variable time based on run time and the (BT) Background Timer :

Fixed BT	Run Time	Computation	Fixed Reduction	Restart Inhibit
30	- 10	= 20	- 50	= -30 = 0
30 + 20	- 10	= 40	- 50	= -10 = 0
30 + 40	- 10	= 60	- 50	= +10
30 + 60	- 10	= 80	- 50	= +30
30 + 80	- 10	= 100	- 50	= +50

- After 110 minutes of run time the RI drops back to 0 and the timer starts over.

Remember; If the motor is cool, the RI is 30 Sec. only.