



TRANE™

Installation

CVRA-IN-2

Library	Service Literature
Product Section	Service Products
Product	CenTraVac
Model	Micro (695) Panel Conversion
Literature Type	Installation
Sequence	2
Date	January 1988
File No.	SV-SP-CTV-CVRA-IN-2-188
Supersedes	

UCP695 Control Panel Conversion Package

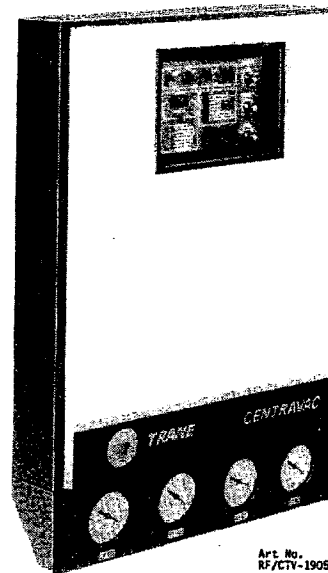

UL-Approved Model CVRA

Designed for Use with these R-11* CenTraVacs:

- CVHEs
- CVHEs w/ASME Condenser Shells
- CVHBs
- CVHBs w/ASME Condenser Shells

- CVHAs
- CVHAs w/ASME Condenser Shells
- PCVs
- PCVs w/ASME Condenser Shells

*Can also be used with most R-113 machines.

Since The Trane Company has a policy of continuous product improvement, it reserves the right to change specifications and design without notice. The installation and servicing of the equipment referred to in this booklet should be done by qualified, experienced technicians.

Table of Contents

3	Model Number Description
4	General Information
4	Literature Change History
4	About this Manual
4	-Warnings and Cautions
4	UCP695 Panel Conversion Package
6	-Conversion Package Contents
6	-Conversion Package Inspection
6	UCP695 Control Panel Operation
8	Existing Control Panel Removal
9	Chiller Control System Conversion
9	CVHE Applications
17	Non-CVHE Applications
17	-Oil Pump Control
18	-Motor Temperature Interface
19	-Guide Vane Linkage
19	-Purge Control
21	Starter Panel Conversion
21	CVHE Applications with Wye-Delta Starters
21	-Removing Nonessential Starter Components
25	-Starter Rework
36	Non-Wye-Delta Starters
36	-Control Power Transformer (2T4)
36	-"Pilot" Relay (2K5)/UCP695 Interface
36	-Starter Transition
37	-Proof of Transition
37	-Starter Control "Extras"
41	Installation Checklist
43	Post-Conversion Checkout
43	Starter Panel Checkout
43	UCP695 Panel/Chiller Checkout

Model Number Description

All standard Trane products are identified by a multiple-character model number that precisely identifies a specific type of equipment.

An explanation of the alphanumeric identification code used with the UCP695 control panel conversion package is provided below. Its use will enable the owner/operator or service technician to define the primary characteristics of a particular "micro panel" retrofit application.

Be sure to refer to the model number printed on the panel nameplate (i.e., mounted on the left-hand side of the UCP695 control panel enclosure) when ordering replacement parts or requesting service.

Model No.

Digit No.

CVRA - 0185 - BB - AA 0

1,2 3 4 5,6,7,8 9 10 11 12 13

Digits 1, 2 CenTraVac

Digit 3 Retrofit Kit

Digit 4 Development Sequence

Digits 5, 6, 7, 8 Unit RLA

See unit nameplate for chiller "rated load amps" (RLA); values range from "0028" thru "1785".

Digit 9 Micro Panel Type

B = Panel w/Bidirectional
Communication Link (BCL)
C = Panel w/Chilled Water Reset (CWR)
D = Free Cooling Panel w/BCL
E = Hot Gas Bypass Panel w/BCL
F = Free Cooling Panel w/CWR
G = Hot Gas Bypass Panel w/CWR

Digit 10 Design Sequence

Digit 11 Chiller Model (Type)

A = CVHE (R-11)
B = CVHB (R-11)
C = CVHA (R-11)
D = PCV (R-11)
E = CVHE (R-11) w/ASME Condenser
Shells
F = CVHE (R-11) w/ASME Condenser
Shells
G = CVHA (R-11) w/ASME Condenser
Shells
H = PCV (R-11) w/ASME Condenser
Shells
J = Other (R-113)

Digit 12 Starter Type (Closed-Transition Only)

A = Star-Delta
B = Across-the-Line
C = Autotransformer
D = Primary Reactor
E = Other

Digit 13 Purge Required

0 = Not Required
1 = Required

General Information

Literature Change History CVRA-IN-2 (January 1988)

Original issue of manual. Describes the conversion procedures required to retrofit an older, electrically- or pneumatically-controlled CenTraVac with a microcomputer-based UCP695 chiller control panel of "B" (or subsequent) design.

About this Manual

The step-by-step instructions outlined in this booklet describe the procedures required to successfully retrofit an older model CenTraVac (e.g., CVHE, CVHB, CVHA or PCV) with a UCP695-based control system.

Notice that the installation instructions in this manual are divided into 3 general topic areas:

1. Existing Control Panel Removal, including removal of the existing inlet vane actuator and—if applicable—purge assembly.

2. Chiller Control System Conversion, including UCP695 control panel, actuator and purge assembly installation on both CVHE and non-CVHE centrifugal chillers.

3. Starter Panel Conversion, including a step-by-step procedure for CVHE/Wye-Delta starter applications, as well as additional instructions for converting Wye-Delta starters used in non-CVHE applications. (These extra modifications are especially important for starter panels with control circuits that are not 115 VAC.)

* * * * *

Note: Wiring diagrams are often referenced throughout this manual. While appropriate schematic and connection diagrams ship with each UCP695 conversion package, a complete set of UCP695 wiring diagrams for CVHE and CVHB applications is also available in CVHE-W-6. You may find it helpful to obtain a copy of this booklet from your local Trane office before you attempt to perform the control system conversion.

Along with the information just described, this manual also recommends the performance of a checkout procedure for the converted starter panel and newly-installed UCP695 control panel. Since specific, step-by-step instructions for portions of this procedure are only described in CVHE service guide CTV-SG-2, contact a qualified service organization (i.e., one with access to this service guide) for assistance.

Successful completion of this checkout procedure assures that the control panel is properly installed, that all required starter and unit modifications are complete, and that the chiller is operating properly.

Caution: To prevent machine damage, contact a qualified service organization to perform the checkout procedure described at the end of this manual!

Warnings and Cautions

Notice that **warnings** and **cautions** appear at appropriate intervals throughout this manual. **Warnings** are provided to alert installing contractors and other personnel to potential hazards that could result in personal injury or death, while **cautions** are designed to alert personnel to conditions that could result in equipment damage.

Your personal safety and the proper operation of this machine depend upon the strict observance of these precautions. The Trane Company assumes no liability for installation or service procedures performed by unqualified personnel.

UCP695 Panel Conversion Package

While the UCP695 control panel conversion package is specifically designed for CVHE applications, it can also be applied to other, older R-11, water-cooled CenTraVacs (PCVs, CVHAs)—whether electrically- or pneumatically-controlled. (Refer to the list of variations for Digit 11 under "Model Number Description".)

Note: When applied to a pneumatic chiller control system, any optional, pneumatically-actuated valves (such as those for hot gas bypass) cannot be used unless the valve actuators are converted from pneumatic to electric devices.

R-113 chillers can also be retrofitted with the UCP695 control panel; however, the UCP's condenser pressure transducer (i.e., used to activate the "head relief request" relay) and condenser limit control features cannot be used. Remember, too, that the condenser high pressure cutout switch (1S1) must be set to trip at 1 psi (rather than 15 psi) for standard R-113 chillers.

While a UCP695 panel conversion package specifically designed for CV and CTV retrofit applications is not available at this time, it is possible to field-adapt the PCV/UCP retrofit kit to early-version Trane—or competitor-built— chillers.

Note: It is important to remember that the UCP695 conversion package is not designed to be applied to air-cooled CenTraVacs, and it cannot be used in conjunction with open-transition starters.

See Figures 1 and 2, respectively, for illustrations of the UCP695 chiller control panel and its component layout.

Figure 1
UCP695 Chiller Control Panel

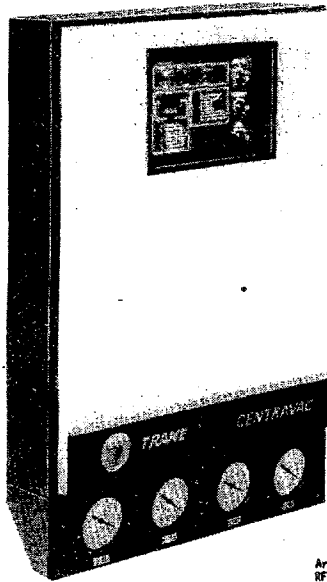

Art. No.
RF/CTV-1905

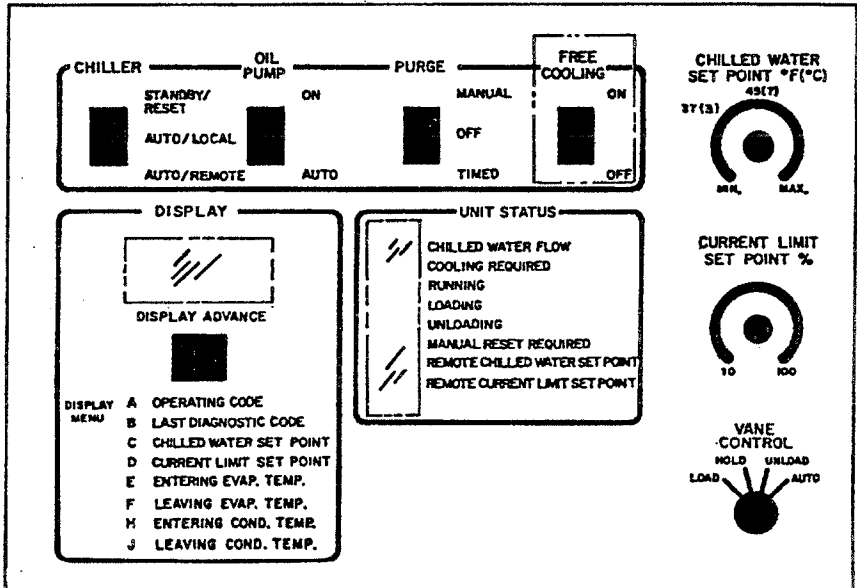

Note: These controls are accessible without opening the control panel door.

Drwg. 6400-0105
(Sheet 6 of 7)

Figure 2
UCP695 Control Panel Layout

Legend

- 1C1 = Oil Pump Capacitor
- 1DL2 = Sump Vent-Line Interval Timer (CVHE Only)
- 1F1 = Oil Pump Fuse
- 1J* = Post Header Power Supply Jacks
- 1K8 = Oil Pump Starter Relay
- 1K9 = Oil Tank Heater Relay
- 1K15 = Hot Gas Bypass Relay (Opt.)
- 1K16 = Chilled Water Pump Relay
- 1K17 = Condenser Water Pump Relay
- 1M1 = Hour Meter
- 1M2 = Start Meter
- 1P* = Post Header Power Supply Plugs

- 1R1 = Condenser Pressure Transducer
- S* = DIP Switch Blocks
- 1S1 = Condenser Hi Pressure Switch
- 1S2 = Differential Pressure Switch
- 1T1 = Power Supply Transformer
- 1TB* = Terminal Blocks
- 1U1 = Relay Output Module
- 1U2 = Power Supply Output Module
- 1U3 = Micro Module

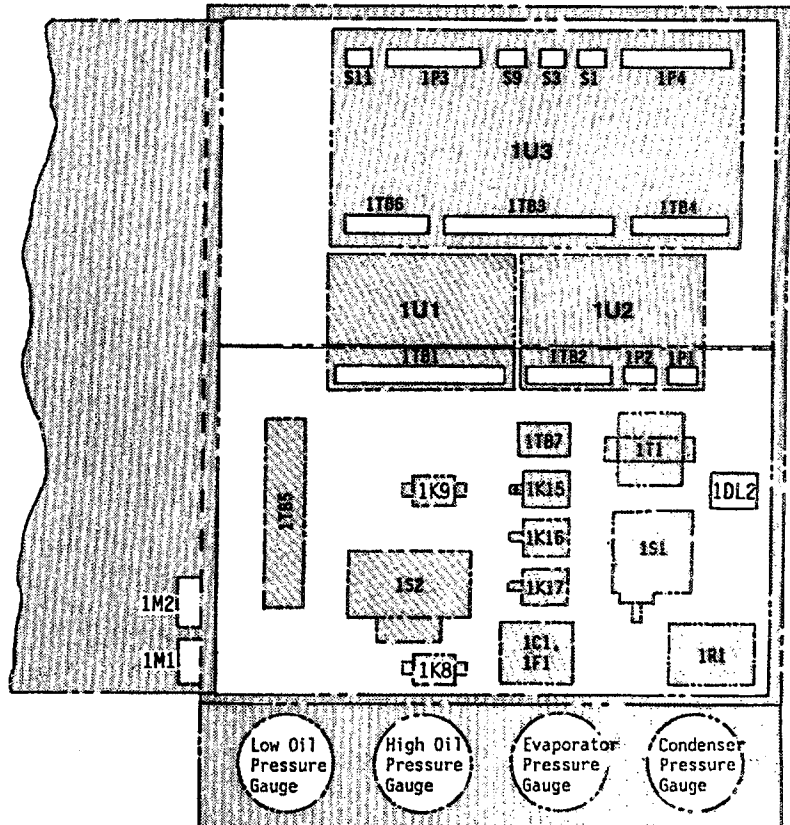

Drwg. 4532-4747

Conversion Package Contents

Each UCP695 panel conversion "kit" includes the items described below. (Some UCP695/GenTraVac retrofit applications require additional field-supplied components; see the "Chiller Control System Conversion" and "Starter Panel Conversion" sections in this manual.)

1 UCP695 chiller control panel and 2 panel mounting brackets (i.e., panel includes integral "alarm" and "head relief request" relays).

Several control panel configurations are available; selection is determined by chiller type and any desired UCP695 control options:

- a. standard UCP695 panel with a bidirectional communications link (BCL) (i.e., required for SCP699 System Control Panel applications);
- b. standard UCP695 panel with chilled water reset (CWR);
- c. free cooling UCP695 panel with BCL;
- d. free cooling UCP695 panel with CWR;
- e. hot gas bypass UCP695 panel with BCL; and,
- f. hot gas bypass UCP695 panel with CWR.

8 temperature sensors, including:

- a. 1 matched-pair of leaving (4RT1) and entering (4RT2) evaporator water temperature sensors with bulbwells;
- b. 1 matched-pair of entering (4RT3) and leaving (4RT4) condenser water temperature sensors with bulbwells;
- c. 2 bearing temperature sensors (4RT8, 4RT9);
- d. 1 evaporator refrigerant temperature sensor (4RT5) with bulbwell; and,
- e. 1 oil sump temperature sensor (4RT7) with bulbwell.

1 inlet vane actuator (4B2)

Note: In non-CVHE applications, 3 adapter brackets are required to enable installation of the new, electric vane actuator. (One bracket secures the actuator to the volute, while the other 2 link the actuator to the actuator arm.) Field fabrication of these brackets may be required in some instances.

6 current transformers (CTs), including:

- a. 3 line CTs (2T1, 2T2, 2T3); and,
- b. 3 auxiliary CTs (2T5, 2T6, 2T7).

1 "proof-of-transition" relay

secondary, 30-amp 2F4 starter fuse (i.e., for control power transformer 2T4; includes fuse block).

terminal strip 2TB1 for starter panel control circuit (i.e., includes identification label for terminals).

miscellaneous electrical and mounting hardware (e.g., washers, screws, etc.)

PRG-72 purge unit assembly (optional; see Figure 3)

drawing package (i.e., includes—but is not limited to—drawings illustrating field wiring connections for remote-mounted starters, sensor placement, unit schematic and connection diagrams for UCP695 control systems, and wye-delta starter panel wiring.)

Conversion Package Inspection

Before installing the UCP695 panel, be sure to compare the data on the panel nameplate with the corresponding ordering and shipping information to verify that the proper UCP695 conversion package was shipped.

If a thorough inspection of the conversion package reveals damage or material shortages, be sure to file these claims with the carrier immediately. Specify the extent and type of damage found, and notify the appropriate Trane sales representative. Do not install a damaged component or panel without the sales representative's approval!

UCP695 Control Panel Operation

For complete descriptions of UCP695 chiller control panel features, operator interface, control options, and electrical sequence(s) of operation, refer to the current revision of CVHE-M-3 or CVHB-M-5. (To obtain a copy of either of these manuals, contact your local Trane office.)

**Figure 3
PRG-72 Assembly**

Top View

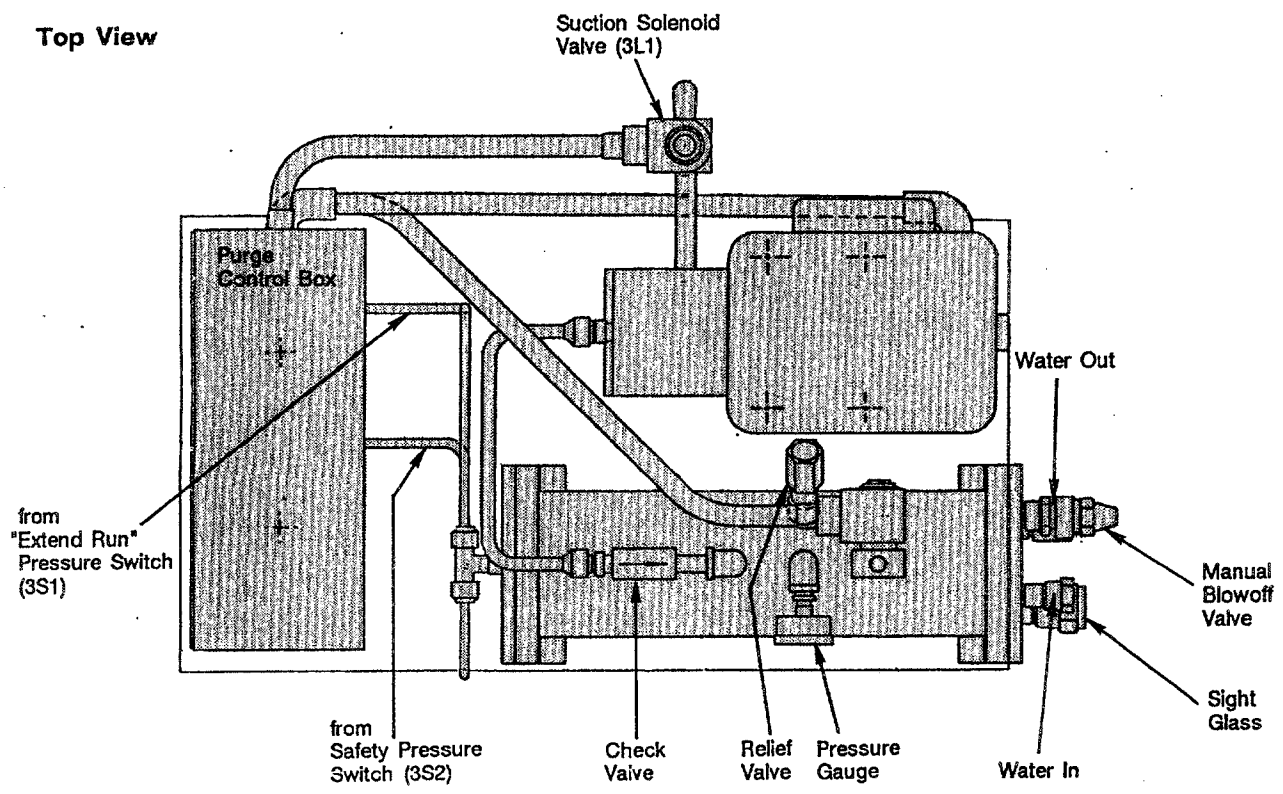

Side View

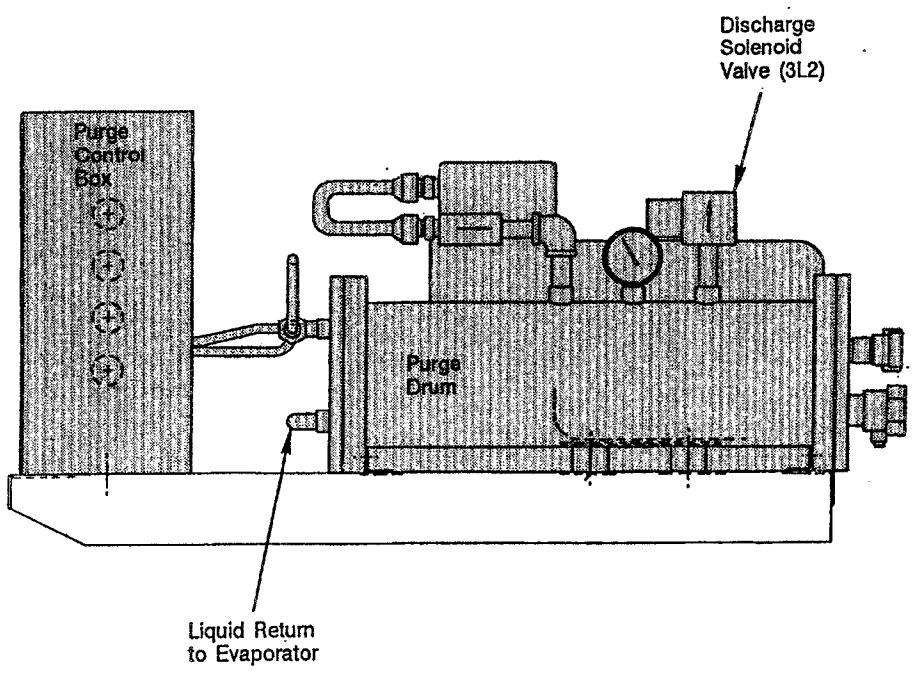

Drwg. 4532-3976E

EXISTING Control Panel Removal

1. Identify all field modifications made to the existing chiller control scheme; then label all field-installed wiring entering the control panel accordingly.

Be sure to look for field-installed circuits that serve as evaporator and condenser flow interlocks, as well as those that provide the following control functions: remote current limiting, remote on/off, "proof-of-running", interface with a building automation system (BAS), etc.

2. Determine how each of the field-adapted control functions just identified (Step 1) will be assumed by the new UCP695 chiller control panel.

Remember that the UCP695 panel:

a. provides all of the control and protection capabilities previously supplied by the AGM capacity control module (U1) and Cutler-Hammer solid-state overload (U2) in existing CVHE control systems.

b. includes isolated contacts to operate all chiller-mounted devices, as well as the starter control circuit.

c. requires 115 VAC control circuit power from the starter panel (since the oil pump, oil heater, vane actuator and purge compressor are all 115-volt devices).

Note: All CVHE control circuits—whether in the starter panel or chiller control panel—are 115-volt systems.

3. Open all starter and control panel disconnect switches and secure them in that position.

WARNING: To prevent injury or death due to electrical shock, verify that all power supply disconnect switches are locked in the OFF position before opening control panel door or disconnecting any wires.

4. Disconnect the leads from the oil heater; then connect a field-supplied thermostat and an auxiliary 115-volt power source to the oil heater.

Be sure to relabel the oil heater leads just disconnected with the "equivalent" wire number designations in the UCP695 control scheme; in this instance, Wire No. 27 becomes "42B", and Wire No. 2 becomes "2V". (Refer to the connection diagram that shipped with the conversion package—or to any of the connection diagrams in CVHE-W-6—for the wire numbers associated with the UCP695 control system.)

5. Disconnect all field-installed wiring entering the control panel (i.e., identified in Step 1) from the control panel terminal strips; then detach the field-installed conduit from the control panel enclosure.

6. Remove the sensors of the start-stop (S3), high oil temperature (S10) and low refrigerant temperature (S2) switches, and place them inside the control panel enclosure.

7. Identify all factory-installed wiring between the unit-mounted components (e.g., vane actuator, oil sump, purge, etc.) and the control panel; make sure that the existing wire numbers on these leads are readable.

Then:

a. Relabel each of these leads with its "equivalent" wire number designation in the UCP695 control scheme. Use the wiring diagrams that shipped with the UCP695 panel to assure that you assign the proper wire numbers.

b. Disconnect each of these wires from the control panel terminal strip.

c. Detach the existing, factory-installed machine conduit from the control panel enclosure. (This conduit will be reused, wherever possible, when the new control panel is installed.)

8. Disconnect the panel pressure gauge lines where they enter the unit; then valve off or plug each unit opening.

9. Disconnect the opposite ends of the pressure gauge lines at the control panel. (Be sure to retain these lines since they will be reused when the new UCP695 control panel is installed.)

10. Cut wire ties—and unbolt conduit connections—as necessary to allow removal of the control panel.

11. Unbolt the control panel from its mounting brackets and remove it from the unit.

12. Remove the chiller nameplate from the control panel enclosure and secure it to the outside of the UCP695 control panel. The information on this original chiller nameplate is required to allow proper part identification of components not affected by the UCP695 conversion.

13. Remove the inlet vane actuator. Be sure to retain all of the connecting hardware and 3 of the five 115 VAC actuator leads. (These will be reused when the new vane actuator is installed.)

14. If a new, micro-compatible PRG-72 purge unit was ordered along with the UCP695 conversion package, remove the existing purge assembly from the chiller.

Chiller Control System Conversion

Replacing an existing CVHE control system with one based on the UCP695 control panel necessitates a number of wiring and hardware changes. Additional modifications are required when this conversion is made on Model CVHB, CVHA or PCV GenTraVacs.

To ensure that the chiller control system retrofit procedure is performed properly, carefully review the instructions in this section, and—if necessary—contact a qualified service organization before beginning the conversion process.

Important! Record a detailed description of all electrical changes made during the UCP695 retrofit process. Be sure to add a copy of this report to the chiller record file for future reference.

CVHE Applications

1. Install the new, upper and lower panel mounting brackets on the chiller.

2. Position the UCP695 control panel on the mounting brackets and secure it in place. Be sure to use the 0.375" star washers (provided) on all panel-to-machine connections to assure proper panel grounding.

3. Verify that the unit is under sufficient vacuum to assure that refrigerant and oil do not leak from the machine when the evaporator refrigerant and oil sump bulbwells are installed. (Installation of these bulbwells necessitates opening the chiller to atmosphere.)

Note: If desired, it is acceptable to remove the chiller's refrigerant charge and evacuate the unit before installing the sensor bulbwells.

4. Install bulbwells for these sensors (i.e., see Figure 4):

Oil Sump Temperature Sensor 4RT7. Install the bulbwell for this sensor in the oil sump well.

Leaving Evaporator Water Temperature Sensor 4RT1. Replace the existing leaving-evaporator bulbwell with the new bulbwell provided in the UCP695 conversion package.

Entering Evaporator Water Temperature Sensor 4RT2 (Optional). Install the bulbwell for this sensor in the coupling that previously held the start-stop switch sensor.

Evaporator Refrigerant Temperature Sensor 4RT5. Keep in mind that some CVHEs with electric control systems were equipped with a single "immersion"-type bulbwell rather than the dual, strap-on type; in these instances, be sure to replace the old bulbwell with the new bulbwell provided in the UCP695 conversion package.

To install the 1/4" well connection for this sensor:

a. Remove the 1/4" angle valve located near the bottom of the evaporator, and install the bulbwell.

However, if shell blockage prevents well installation, then:

b. Use a standard-length, 13/32" drill bit to drill out a 1/4" close-pipe nipple; then connect the nipple to a 1/4" pipe tee. (This apparatus is designed to align the drill bit properly—protecting the threads on the valve boss and preventing the bit from contacting the evaporator tubes during the drilling process.)

c. Thread the nipple-and-tee assembly into the 1/4" valve boss on the evaporator.

d. Using the standard-length, 13/32" drill bit, carefully drill out the evaporator shell blockage.

Note: Drilling out the blockage wears down the close-pipe nipple; therefore, do not use the nipple more than once, or a portion of the threads may break off in the boss.

Caution: The evaporator shell blockage is normally a small section of shell that tends to catch the drill bit. Exercise extreme care to avoid breaking the drill bit!

e. Isolate the evaporator waterside, and monitor water box pressure to verify that none of the evaporator tubes were punctured during the drilling process.

f. Remove the nipple-and-tee assembly from the valve boss, and install the bulbwell provided.

5. Install each of the temperature sensors listed below; see Figure 4.

When the sensor is installed in a bulbwell, be sure to: (1) add thermastic paste to each bulbwell before inserting the sensor; and, (2) ensure that the sensor "bottoms out" at the base of the bulbwell. Though bulbwells are included in the retrofit kit for sensors 5a through 5e (below), sensors 5d and 5e may be installed externally; refer to the note at the top of page 12.

a. evaporator refrigerant temperature sensor 4RT5

b. oil sump temperature sensor 4RT7

c. leaving evaporator water temperature sensor 4RT1

d. entering evaporator water temperature sensor 4RT2

e. optional entering and leaving condenser water temperature sensors 4RT3 and 4RT4

Figure 4 Field Wiring Layout and Sensor Locations

NOTES:

1. DASHED LINES INDICATE FIELD WIRING BY OTHERS. PHANTOM LINES INDICATE ALTERNATE CIRCUITRY OR AVAILABLE SALES OPTION. CHECK S.O. TO DETERMINE IF WIRING IS REQUIRED FOR SPECIFIC OPTIONS.
2. ALL FIELD WIRING MUST BE IN ACCORDANCE WITH THE NATIONAL ELECTRIC CODE (NEC), STATE AND LOCAL REQUIREMENTS. OTHER COUNTRIES APPLICABLE NATIONAL AND/OR LOCAL REQUIREMENTS SHALL APPLY.
3. AUXILIARY CONTROLS FOR A CUSTOMER SPECIFIED OR INSTALLED LATCHING SAFETY TRIP-OUTS.
4. THE FOLLOWING CAPABILITIES ARE OPTIONAL- THEY ARE IMPLEMENTED AND WIRED AS REQUIRED FOR A SPECIFIC SYSTEM APPLICATION.
 - A CHILLED WATER RESET- REQUIRES MATCHED PAIR OF THERMISTORS FOR 4RT1 & 4RT2. IF AMBIENT TEMP BASED CHILLED WATER RESET IS REQUIRED, USE STD SUPPLIED LEAVING EVAP TEMP SENSOR (4RT1) FOR 4RTS AS AN AMBIENT TEMP SENSOR.
 - B RELAY PACKAGE- INCLUDES HEAD RELIEF REQUEST AND REMOTE ALARM CIRCUIT.
 - C ENTERING EVAP TEMP SENSOR- REQUIRES MATCHED PAIR OF THERMISTORS FOR 4RT1 & 4RT2.
 - D ENTERING AND LEAVING CONDENSER WATER TEMP SENSORS MATCHED PAIR OF THERMISTORS FOR 4RT3 & 4RT4.
 - E TRACER MONITORING PACKAGE INCLUDES OPTIONS C AND D PLUS THERMISTOR FOR 4RT5 TO BE USED AS CONDENSER REFRIGERANT TEMP SENSOR.
5. FOR SENSOR DISCRPTION SEE B4533-1710.

WIRING REQUIREMENTS

DO NOT RUN LOW VOLTAGE WIRE (30 VOLTS MAX) IN CONDUIT OR RACEWAY WITH HIGHER VOLTAGE WIRE.

REQUIRED WIRING:

- 21 9 WIRES 2-#10 AWG 600V, 7-#14 AWG 600V
- 22 8 WIRES #14-#16 AWG 600V, RUN IS SEPARATE COUDUIT. USE #16 AWG UP TO 250 FT ONEWAY OR #14 AWG UP TO 400 FT ONEWAY
- 23 COPPER WIRE ONLY SIZED PER N.E.C. 1984 BASED ON NAMEPLATE RLA SEE TABLE 1
- 24 4 WIRES #14 AWG 600V, SEPARATE 115 VAC POWER IS REQUIRED TO STARTER
- 25 2 WIRES #14 AWG 600V
- 26 2 WIRES #14-#18 AWG 600V, DO NOT RUN IN CONDUIT WITH HIGHER VOLTAGE WIRE SEE TABLE 2

OPTIONAL WIRING

- 27 3 WIRES #14 AWG 600V, SEPARATE 115 VAC POWER SUPPLY IS REQUIRED
- 28 2 WIRES #14 AWG 600V, SEPARATE 115 VAC POWER SUPPLY IS REQUIRED
- 29 2 WIRES #14 AWG 600V
- 30 2 WIRES #14-#18 AWG 600V, DO NOT RUN IN CONDUIT WITH HIGHER VOLTAGE WIRE SEE TABLE 2
- 31 SHIELDED TWISTED PAIR. 30V OR LESS #14-#18 AWG 600V. MAX LENGTH 5000FT. DO NOT RUN IN CONDUIT WITH HIGHER VOLTAGE WIRE.
- 32 IF UNIT IS SUPPLIED WITH UNIT MOUNTED STARTER, FIELD WIRING BETWEEN UNIT AND STARTER IS NOT REQUIRED.

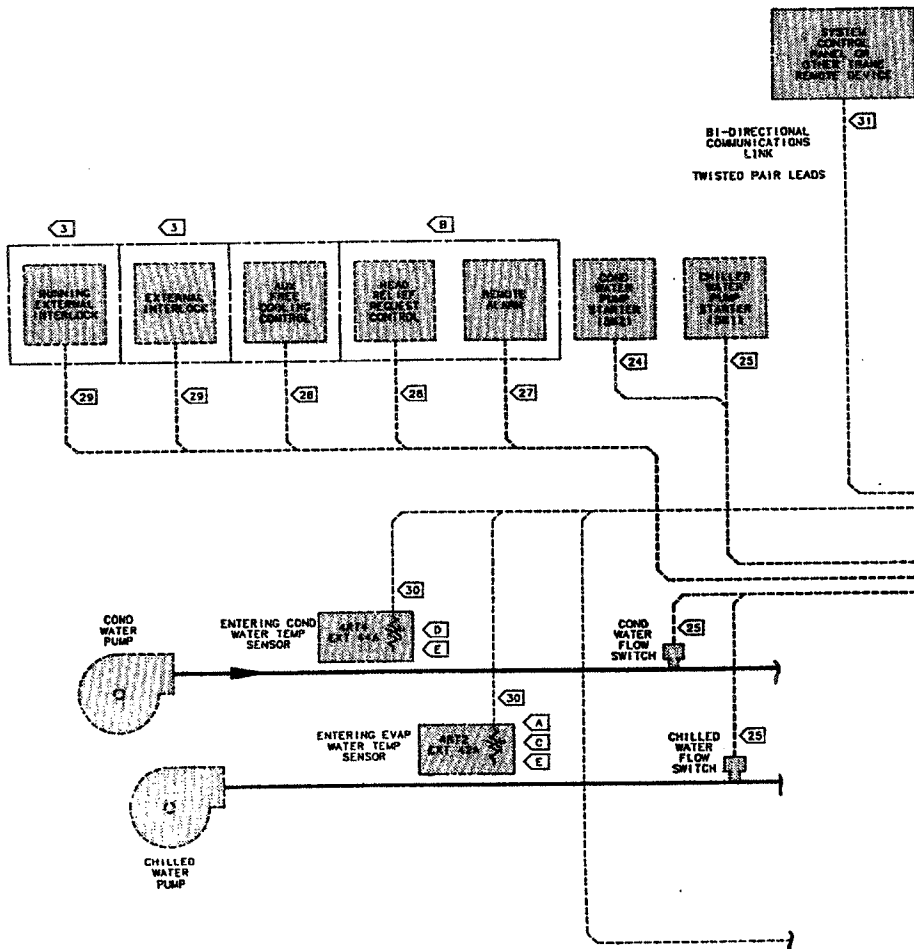

(Continued on next page)

WARNING
DISCONNECT ELECTRICAL POWER
SOURCE TO PREVENT INJURY OR
DEATH FROM ELECTRICAL SHOCK

CAUTION
Use copper conductors only
to prevent equipment damage

TABLE 1
RECOMMENDED WIRE SELECTION TABLE (REF. NEC 1984)
RATED LOAD CURRENT (NAMEPLATE)

MIN. WIRE SIZE COPPER 75° C	SUPPLY LEADS OR MOTOR LEADS FOR ACROSS-THE-LINE, AUTO-TRANS STARTER OR PRIMARY REACTOR STARTER					
	1 CONDUIT 3 WIRES		2 CONDUITS 3 WIRES EA		1 CONDUIT 6 WIRES	
	1	2	1	2	1	2
8	40	N/A	N/A	88.2	55.4	
6	52			80.0	72.0	
4	68			117.6	94.1	
3	80			138.4	110.7	
2	92			159.2	127.3	
1	104			179.0	143.9	
0	120	240	192.0	207.8	166.1	
00	140	280	224.0	242.2	183.8	
000	160	320	256.0	276.8	221.4	
0000	184	368	294.4	318.3	254.7	
200	204	408	328.4	352.9	282.3	
300	228	456	364.8	394.4	315.6	
350	248	496	396.8	428.0	343.2	
400	268	536	428.8	463.6	370.9	
500	304	608	486.4	525.9	420.7	
600	336	672	537.6	581.3	465.0	

TABLE 2

WIRE WIRE	MAX LENGTH FOR SENSOR LEADS
14 AWG	5000 FT
18 AWG	2000 FT
18 AWG	1000 FT

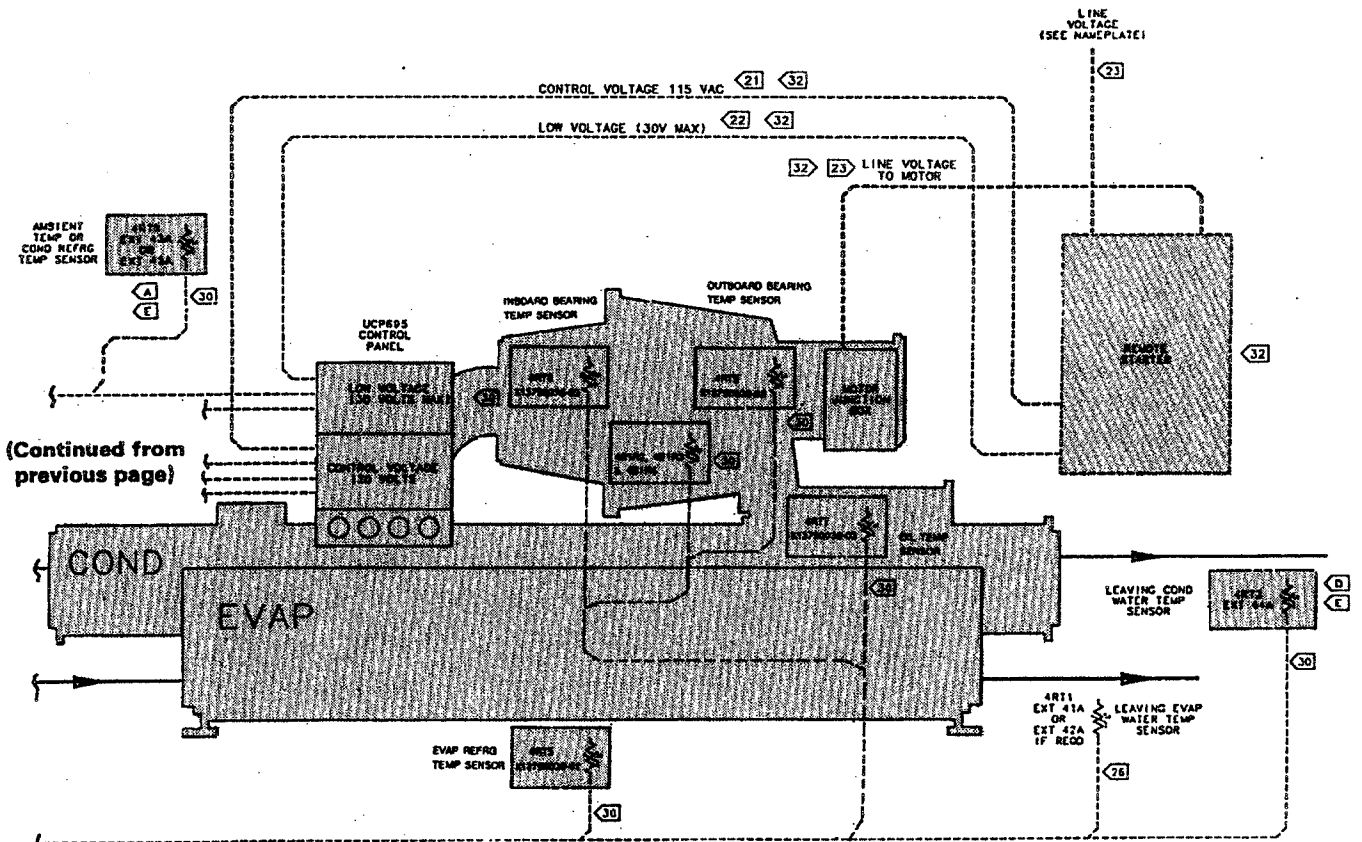

Drwg. X39470473D

CVRA-IN-2

Note: If the bulbwells provided for the entering evaporator—or entering and leaving condenser—water temperature sensors cannot be installed conveniently, each sensor may be mounted to the outside of the appropriate water pipe. To do this:

(a) Remove the paint and rust from the pipe surface; then use an emery cloth to expose bare metal.

(b) Epoxy the sensor to the pipe surface with a heat-conductive adhesive. Use "Output High-Strength Adhesive" by Loc-Tite (Part No. 00240), or equivalent.

(c) Wrap the sensor with Armaflex insulation.

WARNING: "Loc-Tite" adhesive is an eye irritant, and may irritate sensitive skin. If adhesive comes in contact with skin, flush affected area with water for 15 minutes and seek medical attention.

f. bearing temperature sensors 4RT8 and 4RT9

Use a heat-conductive adhesive (see preceding note) to secure each of these sensors to the underside of the bearing oil return lines; locate each sensor beneath the section of line that angles downward at a 45-degree angle.

Before installing the sensors, be sure to remove any paint and rust from the line surfaces; then use an emery cloth to expose bare metal. Once the sensors are secured in place, wrap each with Armaflex insulation.

6. If the chiller is equipped with PRG-71 or PRG-70 (and the chiller will not be retrofitted with PRG-72 at this time), then the existing purge wiring must be modified so that its operation is governed by the UCP's 1U1K9 contacts. See Figure 5. This modification requires:

a. connection of the existing purge control circuit to the UCP695 panel at Terminal 1TB1-7;

**Figure 5
Electrical Connections
Required for PRG-72, -71 and -70**

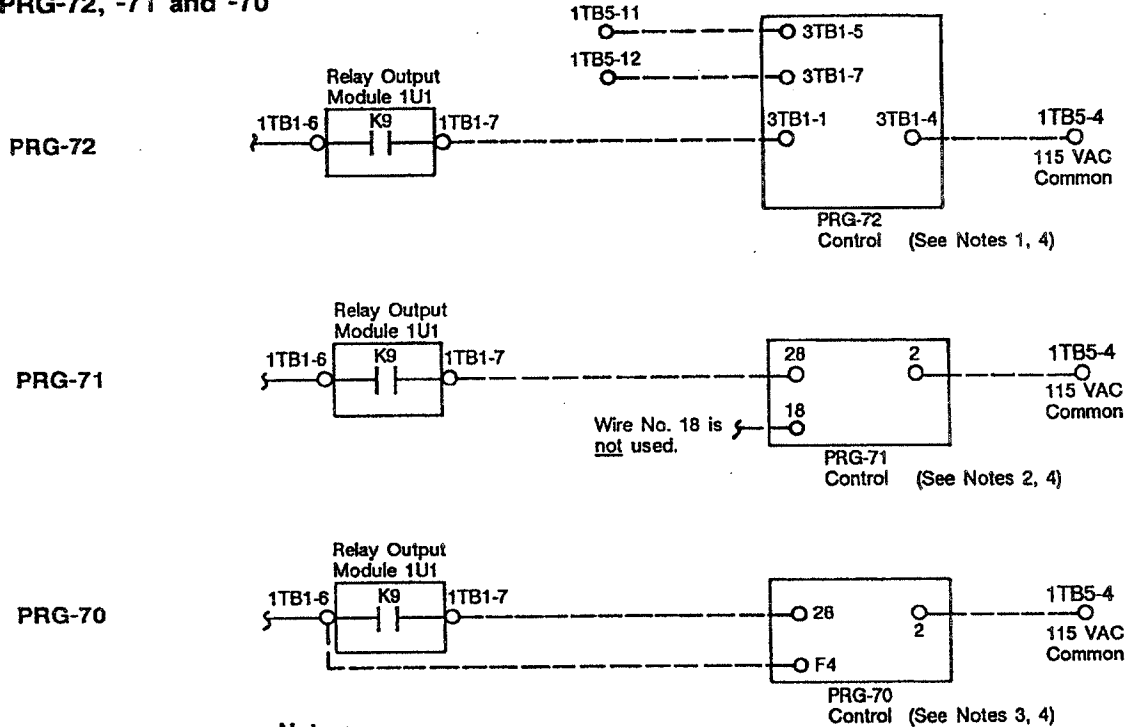

Notes:

1. Operation of PRG-72 is described in the current edition of CVHE-M-3, as well as in CVHB-M-5.
2. PRG-71's adjustable timer must be disconnected to allow micro module 1U3 to control purge compressor "on" time when the purge switch is set at "Timed". (The purge switch is located on the front of the UCP695 control panel.)
3. Electrical connections shown above enable PRG-70 to operate for 5 minutes out of every 2-hour interval, but only if: (1) the chiller switch is set at either "Auto/Local" or "Auto/Remote", (2) there is chilled water flow, and, (3) the chiller is running.
4. Purge operation is continuous—regardless of chiller switch position—when the purge switch is set at "Manual".

b. retention of all existing purge safety controls;

c. connection of the purge ground wire to control panel Terminal 1TB5-4 to complete the power circuit; and,

d. on PRG-70 only, connection of the purge heater wire to Terminal 1TB1-6.

However, if PRG-72 was ordered with the UCP695 conversion package, mount it at or above the purge connection on the condenser; then, using Figure 5 as a guide, complete the wiring connections between the new purge assembly and the UCP695 control panel.

Note: Neither PRG-70 nor PRG-71 includes a drum-mounted gauge, and—unlike the old control panel—the UCP695 panel does not include a purge pressure gauge. If you wish to continue to monitor purge drum pressure, remove the purge gauge from the old control panel and install it in a convenient location on the purge assembly.

Important! The purge suction line of chillers with PRG-71 or PRG-72 must slope back toward the condenser. This prevents liquid slugging (and the blown head gasket that often results) from occurring in the purge compressor.

7. Install the new inlet guide vane actuator on the chiller; use the connecting hardware retained when the

old actuator was removed. Do not connect the guide vanes at this time! (Vane motor travel must be checked before the guide vanes are connected to the actuator; see "Post-Conversion Checkout: UCP695 Panel/Chiller Checkout".)

8. Connect all low-voltage wiring (i.e., less than 30 volts) between the unit-mounted controls and the UCP695 control panel. (This includes the panel connections for the temperature sensors just installed, as well as for the existing motor winding temperature sensors, vane actuator end switch, and any optional valve end switches.)

Refer to Tables 1 and 2 for panel connection points, as well as to the wiring diagrams that shipped with the UCP695 panel.

Table 1
UCP695 Temperature Sensor Locations and Electrical Connections

Temperature Sensor			Electrical Connections	
Elec. Design	Description (Note 1)	Physical Location	Wire Nos.	Cont. Panel Terminations
4RT5	Evaporator Refrigerant Temperature Sensor (Vendor # X13790038-02; Trane Mnemonic # SEN-136)	Lower evaporator well	102A 103A	1TB3-12 "-13
4RT7	Oil Temperature Sensor (Vendor # X13790038-03; Trane Mnemonic # SEN-137)	Oil sump well	110A 111A	1TB4-13 "-14
4RT1 (Note 2)	Lvg. Evaporator Water Temperature Sensor (Vendor # X13790038-04; Trane Mnemonic # SEN-131)	Connecting water piping (water <u>out</u>)	104 105	1TB3- 1 "- 2
4RT2 (Note 2)	Ent. Evaporator Water Temperature Sensor (Vendor # X13790038-04; Trane Mnemonic # SEN-131)	Connecting water piping (water <u>in</u>)	121 122	1TB3- 3 "- 4
4RT3 (Note 2)	Opt. Ent. Condenser Water Temp. Sensor (Vendor # X13790038-04; Trane Mnemonic # SEN-131)	Connecting water piping (water <u>in</u>)	123 124	1TB3- 5 "- 6
4RT4 (Note 2)	Opt. Lvg. Condenser Water Temp. Sensor (Vendor # X13790038-04; Trane Mnemonic # SEN-131)	Connecting water piping (water <u>out</u>)	125 126	1TB3- 7 "- 8
4RT8	Opt. "Inboard" Bearing Temperature Sensor (Vendor # X13790038-03; Trane Mnemonic # SEN-137)	Epoxy to compressor-end oil return line	133 134	1TB4-19 "-20
4RT9	Opt. "Outboard" Bearing Temperature Sensor (Vendor # X13790038-03; Trane Mnemonic # SEN-137)	Epoxy to opposite-compressor-end oil return line	135 136	1TB4-21 "-22
4B1R2	Existing Motor Winding Temperature Sensor	Motor housing	BLK RED	1TB4-15 "-17
4B1R3	Existing Motor Winding Temperature Sensor	Motor housing	WHT RED	1TB4-16 "-17
4B1R4	Existing Motor Winding Temperature Sensor	Motor housing	GRN RED	1TB4-18 "-17

Notes:

- Trane's mnemonic part number appears on the outside of the box containing the sensor(s); the vendor code number is stamped on the sensors.
- One of a matched sensor pair. Sensors used as a matched pair must be replaced as a pair; do not replace an individual sensor from a pair!

**Table 2
Field Wiring Requirements
between UCP695 Panel and
Unit-Mounted Controls**

Standard Unit-Mounted Controls	115-Volt Control Circuits (1)				230-Volt Control Circuits (2)			
	No. of Wires	Device Term.	Wire Nos.	Panel Term.	No. of Wires	Device Term.	Wire Nos.	Panel Term.
Vane Actuator Motor 4B2 (See Note 3)	3	M1	25A	1TB1- 2	2	4	108A	1TB3-24
		M2	24A	1TB1- 1		5	109A	1TB3-25
		2	23D	1TB5-10				
Oil Tank Heater 4HR1	2	4HR1	2V 42B	1TB5- 4 1TB5-14				
Oil Pump Motor 4B3	3	1	22B	1TB5- 8				
		2	2M	1TB5- 3				
		3	20B	1TB5- 7				
PRG-72 Purge Unit 3TB1	4	3TB1-1	27A	1TB1- 7				
		3TB1-4	2P	1TB5- 4				
		3TB1-5	26D	1TB5-12				
		3TB1-7	31B	1TB5-13				
PRG-71 Purge Unit (Wire No. 18 is <u>not</u> used.)	2	28	28	1TB1- 7				
		2	2	1TB5- 4				
PRG-70 Purge Unit	3	28	28	1TB1- 7				
		F4	F4	1TB1- 6				
		2	2	1TB5- 4				
Interlock Ckts. for Flow Switches/Water Pumps								
Evaporator	2	5S2	3	1TB5-15				
		5K1	15	1TB5-17				
Condenser--Interlock	2	5S3	3	1TB5-16				
		5K2	16	1TB5-18				
Condenser--Pump Ckt. (See Figure 9)	2	5K2	92	1TB1- 5				
		5K2	91	1TB1- 4				
Hot Gas Bypass Option								
HGBP Valve 4B5	5	1	23E	1TB7- 1				
		2	35A	4S4- NO				
		4	36A	1TB7- 4				
		5	24A	1TB1- 1				
		6	32A	4B2- M2				
HGBP Damper Linkage End (Transfer) Switch 4S4	3	C	28A	1TB7- 3				
		NC	33B	1TB7- 2				
		NO	35A	4B5- 2				
Vane Actuator Motor 4B2 (See Note 3)	3	M1	33A	1TB7- 2	2	4	108A	1TB3-24
		M2	32A	4B5- 6		5	109A	1TB3-25
		2	23D	1TB5-10				
Discharge Temperature Switch 4S5					2	4S5	129A 130A	1TB4- 3 1TB4- 4
Free Cooling Option								
Gas Line Valve 4B13	3	1	2AH	1TB5- 4	2	5	120B	4B12- 6
		2	37A	1TB1-19		6	119A	1TB3-19
		3	46A	1TB1-18				
Liquid Line Valve 4B12	3	1	2AG	1TB5- 3	2	5	118A	1TB3-18
		2	45A	1TB1-16		6	120A	4B13- 5
		3	34A	1TB1-15				

Notes:

1. Use #14 AWG, 600V wire for these circuits. Remember that all 115-volt wiring must be run in conduit and separated from all low-voltage wiring (i.e., circuits carrying less than 30 volts).
2. Use either (a) SJO (jacketed) cable, (b) shielded, twisted-pair conductors, or (c) individual wires in conduit for all low-voltage circuits (i.e., less than 30 volts). Wiring sizing is #14 to #18 AWG, 600V. Never run any of these low-voltage circuits in conduit with higher voltage wire!
3. Wire numbers and panel termination points for Terminals M1 and M2 of vane actuator motor 4B2 in a HGBP unit are not the same as those in a standard or free cooling unit.

**Figure 7
Electrical Connections for
Hot Gas Bypass Valve (4B5)**

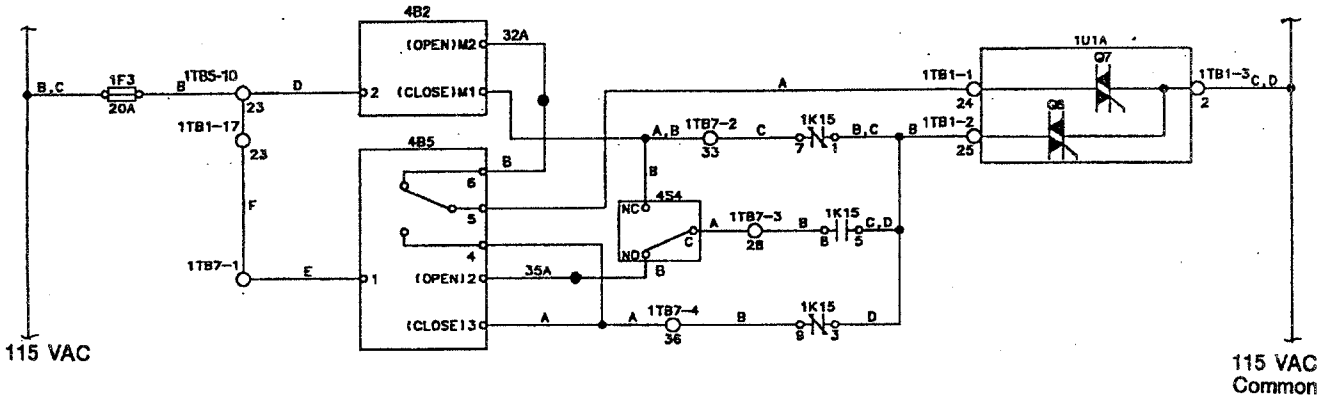

WARNING
Disconnect electrical power supply to prevent injury or death due to electrical shock.

Caution
Use copper conductors only to prevent equipment damage (unless otherwise specified).

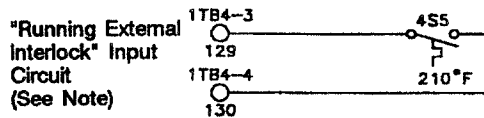

- Legend**
- 1F3 Branch Circuit Fuse
 - 1K15 HGBP Relay
 - 1U1 Relay Output Module
 - 4B2 Vane Actuator Motor
 - 4B5 HGBP Valve
 - 4S4 HGBP Transfer Switch
 - 4S5 Discharge Temp. Switch

Note: When unit is equipped with HGBP option, micro module 1U3's "running external interlock" input terminals (1TB4-3, -4) are used for discharge temperature switch 4S5. Wiring to these terminals is low voltage (i.e., less than 30 volts); use #14 AWG, 600V wire, and run this circuit in separate conduit.

**Drwgs. X39470494A,
X39470495A**

Unless otherwise indicated, all 115-volt control circuits use #14 AWG, 600-volt wire. Be sure to use existing conduit and wire whenever possible, and separate all 115-volt wiring from the low-voltage circuits.

Note: To distinguish which circuits carry low voltage (i.e., less than 30 volts), remember that:

a. all connections made at UCP695 control panel terminal strips 1TB3, 1TB4 and 1TB6 are low voltage;

b. #14 to #18 AWG, 600-volt wires are used for low-voltage circuits; and,

c. these circuits typically consist of either SJO [jacketed] cable, shielded, twisted-pair leads, or individual wires in conduit.

Caution: To prevent possible control malfunction due to electrical noise, never route low-voltage circuits with other conductors carrying 30 or more volts!

10. Complete the pressure gauge piping connections between the UCP695 control panel and the chiller using the gauge lines retained from the old control panel.

* * * * *

This completes conversion of the chiller control system. To modify the existing starter panel for compatibility with the new UCP695 panel, complete the procedure described in the "Starter Panel Conversion" section of this manual.

Non-CVHE Applications

Installation of a UCP695 panel on a non-CVHE chiller is similar to the process used to convert a CVHE unit; however, several additional machine modifications are required in the oil pump and purge unit control circuits, motor temperature interface, and guide vane linkage.

Each of these modifications is described below. Use this information—along with the instructions provided for CVHE applications—to adapt the existing chiller controls to the UCP695 control system.

Note: Keep these points in mind when retrofitting an "older" CenTraVac (i.e., CVHB, CVHA or PCV) with a UCP695 control panel:

a. The UCP695 control panel can be installed on pneumatically-controlled units, but any optional, pneumatically-actuated valves (e.g., HGBP), cannot be used unless the valves can be refitted with electric actuators.

b. R-113 units can be converted, but the condenser pressure transducer and condenser limit control features cannot be used. Also, the HPC of these units must be set at 1 psi (rather than at 15 psi, as on R-11 units).

Oil Pump Control

If the existing oil pump contactor coil is:

1. 115 VAC, then:

a. Connect the existing contactor coil between Terminals 1TB5-11 and 1TB5-4. See Figure 8.

b. Remove oil pump start relay 1K8 and start capacitor 1C1 from the UCP695 panel; see Figure 2. (The existing oil pump contactor coil will now assume the functions performed by these devices.)

Figure 8
Electrical Interface for Existing Oil Pump Motor Contactor

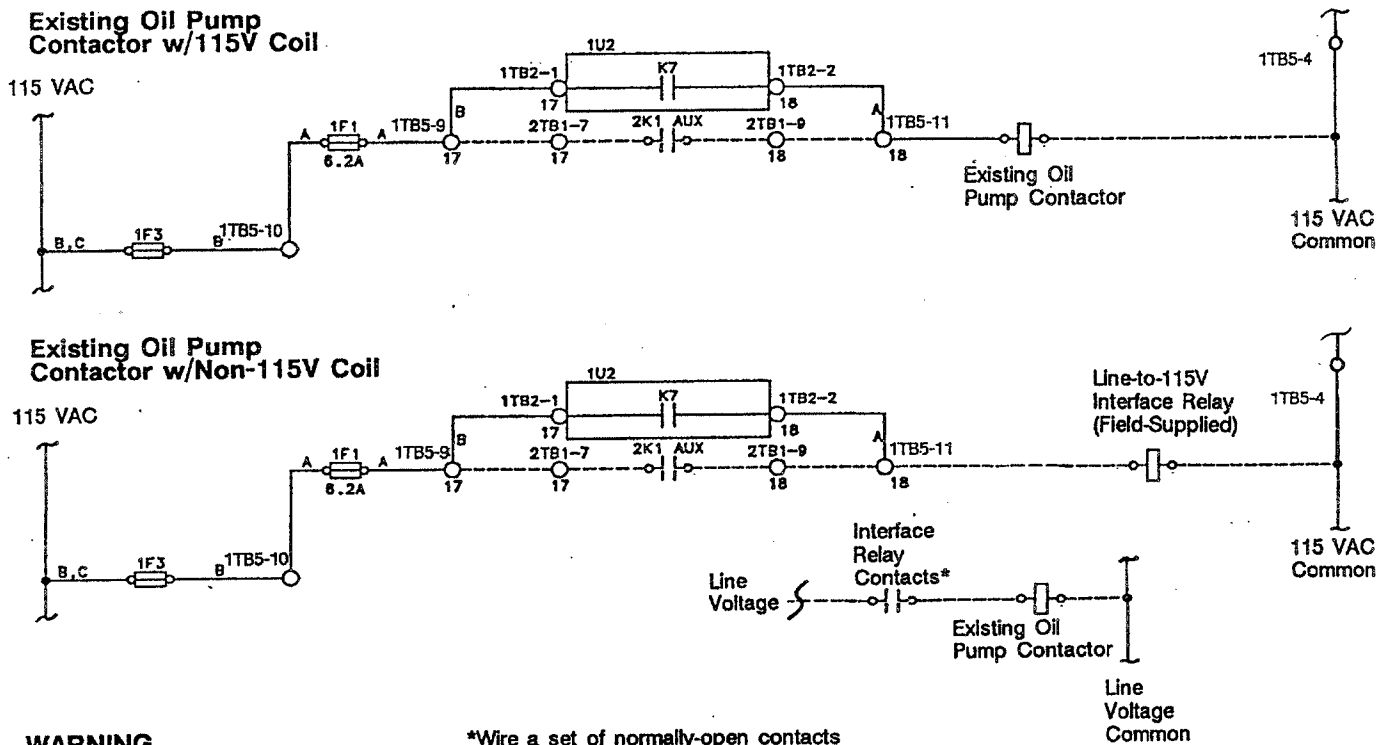

WARNING
Disconnect electrical power supply to prevent injury or death due to electrical shock.

Caution
Use copper conductors only to prevent equipment damage (unless otherwise specified).

*Wire a set of normally-open contacts in series with the existing oil pump motor contactor coil whenever that coil is not 115 volts.

Note: Since closure of the K7 contacts is governed by micro module (1U3) control logic, the K7 relay coil is not shown.

Legend

- 1F1 Oil Pump Fuse
- 1F3 Branch Circuit Fuse
- 1U2 Power Supply Output Module
- K7 Oil Pump Relay (See Note)
- 2K1 Start Contactor

Ref. Drwg. X39470486A

2. not 115 VAC but can be converted, then adapt the contactor coil for 115V applications and complete Steps 1a and 1b above.

3. not 115 VAC and cannot be converted, then:

a. Remove oil pump start relay 1K8 and start capacitor 1C1 (Figure 2) from the UCP695 panel.

b. Connect the coil of a field-supplied "line-to-115V interface relay" (with normally-open contacts) between Terminals 1TB5-11 and 1TB5-4, as shown in Figure 8.

c. Wire the "interface relay" contacts in series with—and upstream of—the existing oil pump contactor coil. See Figure 8.

Note: In all instances—regardless of oil pump contactor voltage, connect an auxiliary set of "start" contactor (2K1) contacts between UCP Terminals 1TB5-9 and 1TB5-11 to assure that the oil pump is on whenever the compressor is operating.

Motor Temperature Interface

To convert a chiller with the Robertshaw module and RTD sensors, connect UCP695 Terminals 1TB4-15 through

1TB4-18 directly to the RTD terminals on the motor. Remember that these circuits are low-voltage (i.e., less than 30 volts), and must be separated from higher-voltage circuits.

Caution: To prevent possible control malfunction due to electrical noise, never route low-voltage circuits with other conductors carrying 30V or more!

If the chiller's motor temperature-sensing device is a thermostat, connect it to an isolation relay and resistors (all field-supplied) that simulate the 3 RTD sensors presently used for motor temperature protection. See Figure 9.

Note: To assure proper operation, the thermostat's contacts must be normally-closed, and open on a rise in motor temperature.

Figure 9
Interfacing Existing Motor Temperature Thermostat w/UCP695 Control Panel (See Note 3)

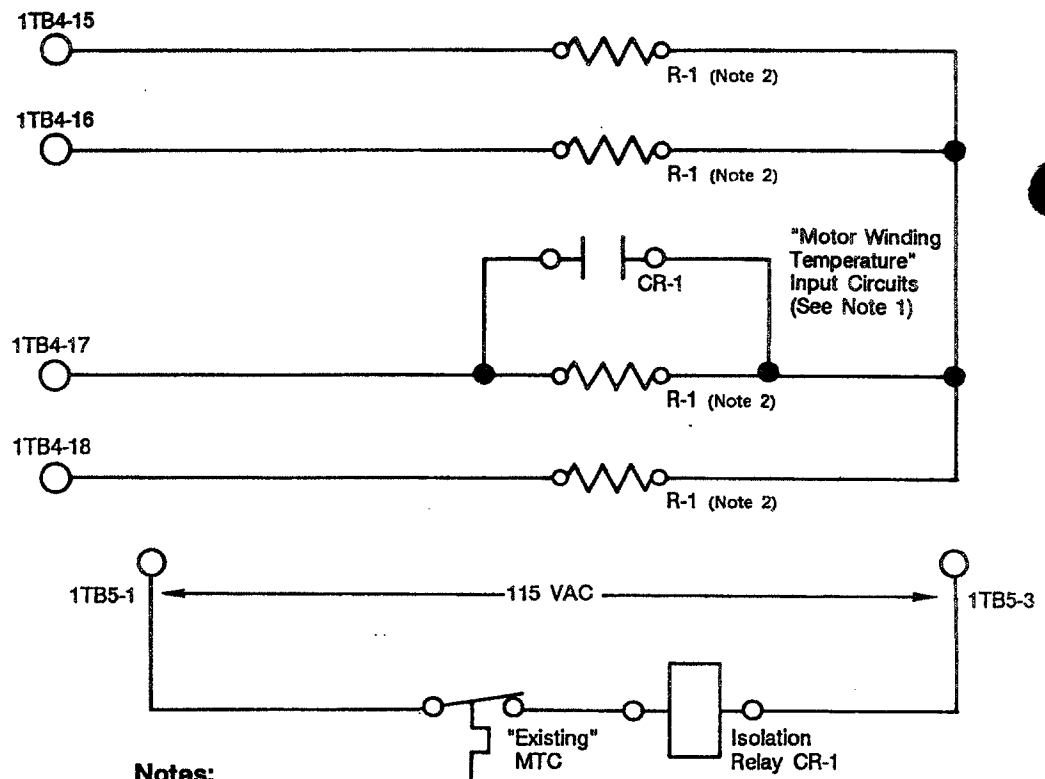

WARNING
Disconnect electrical power supply to prevent injury or death due to electrical shock.

Caution
Use copper conductors only to prevent equipment damage (unless otherwise specified).

Notes:

1. Wiring to micro module 1U3's 1TB4 terminal strip is low voltage (i.e., less than 30 volts).
2. "R-1" resistors are of carbon composition, and are rated at 75 ohms/0.5 watt.
3. This electrical configuration must be used whenever the existing motor temperature control (MTC) is a thermostat. Notice that the thermostat must include normally-closed contacts that open on a rise in temperature.
4. The "CR-1" isolation relay and 4 "R-1" resistors must be field-supplied.

Guide Vane Linkage

The electric actuator provided in the UCP695 conversion package is 1-3/8" longer—when fully retracted—than the pneumatic actuator used on "older" GenTraVacs. Therefore, the existing linkage must be corrected to ensure that the vanes are closed when the actuator is retracted.

Use the actuator mounting plate, piston yoke and mounting hardware provided to install the new electric actuator. See Figure 10.

(Specific installation instructions are described on the actuator installation drawings—similar to those shown in Figure 10—included in the conversion kit. Select the appropriate drawing for your unit.)

Note: When the new electric actuator is installed on either PCV-2C through -3J units, or CVHA-022 through -038 units, be sure to change the motor stroke from 5" to 4". (See Step 4 of "UCP695 Panel/Chiller Checkout" for instructions.)

Purge Control

Review the information presented in Figure 5 (page 12); then connect the existing purge control to the UCP as shown. (The UCP695 panel will then operate the purge 5 minutes for every 2 hours of chiller operation if the UCP695 panel's purge switch is set at "Timed". Remember that if this switch is set at "Manual", the purge will operate continuously, regardless of the position of the chiller switch!)

Note: Be sure to retain all existing purge safety controls!

* * * * *

This completes the unit control system conversion for a non-CVHE unit. To modify the existing starter panel for compatibility with the new UCP695 panel, complete the instructions described in the "Starter Panel Conversion" section of this manual.

Figure 10
Mounting New Vane
Actuator Motor

for
 PCV-2C thru -3J, and
 CVHA-022 thru -038

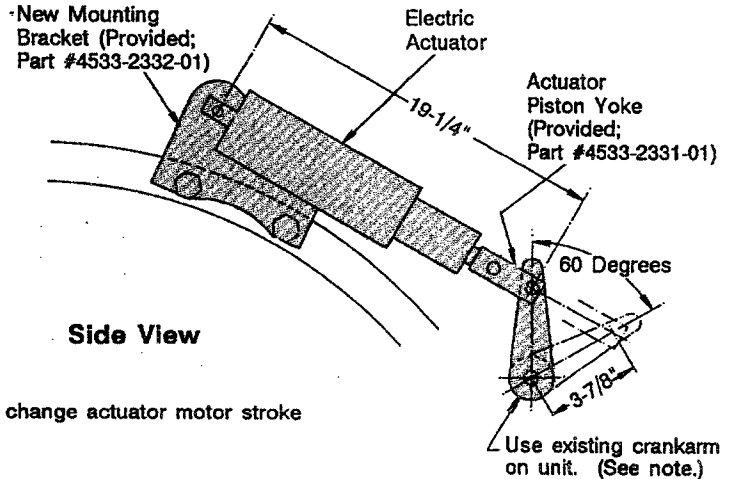
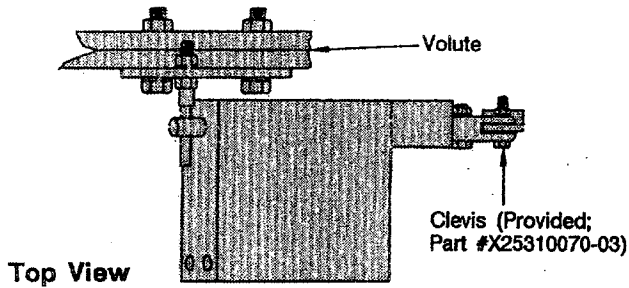

Note: Be sure to change actuator motor stroke from 5" to 4".

Drwg. 4533-2336

for
 CVHA-044 thru -055

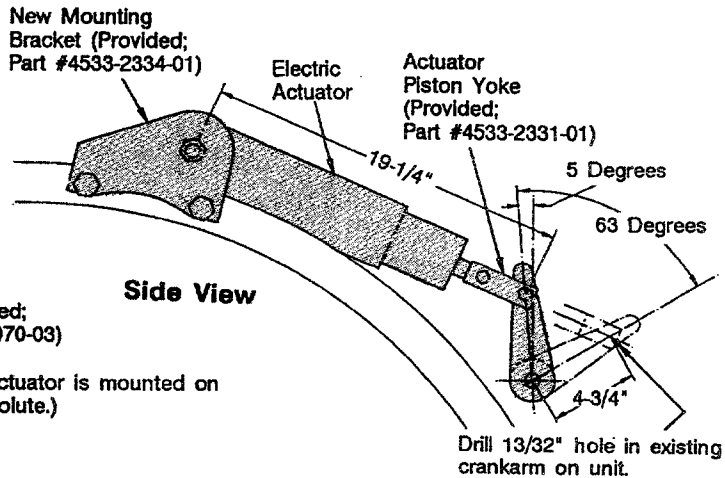
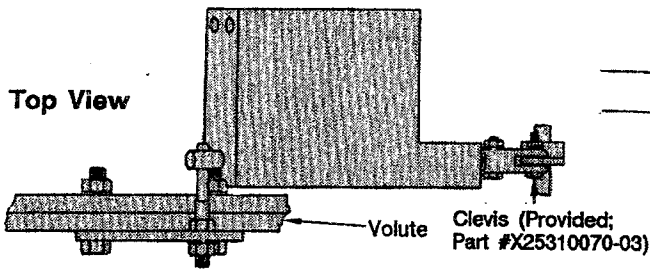

(Notice that actuator is mounted on "outside" of volute.)

Drwg. 4533-2337

for
 PCV-4F thru -5D

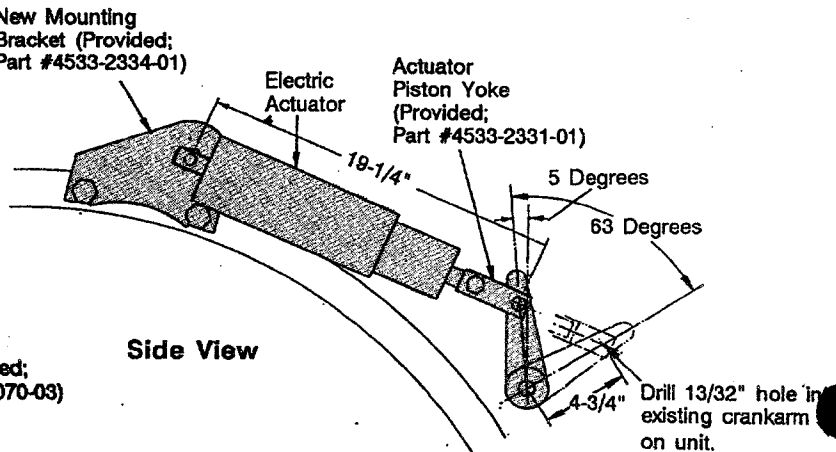
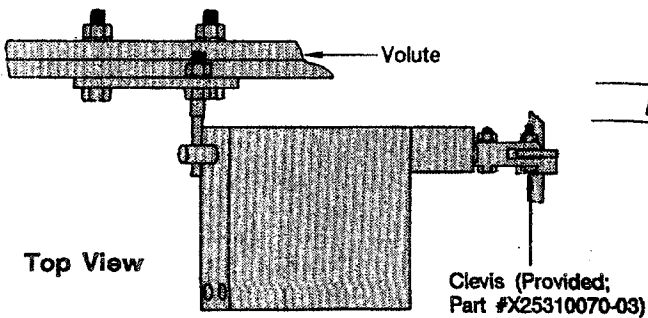

Drwg. 4533-2338

Starter Panel Conversion

Starter panel conversion varies with existing starter type and starter control voltage. Remember, however, that any starter panel used in conjunction with a UCP695 control panel must be of "closed-transition" design—or converted to "closed-transition"!

Altering an existing Wye-Delta/CVHE starter for compatibility with the new UCP695 panel involves a number of wiring and hardware changes. Other modifications are required if the starter is not a Wye-Delta type, or if the chiller is not a CVHE.

To ensure that the starter panel retrofit procedure is performed properly, carefully review the instructions in this section, and—if necessary—contact a qualified service organization before beginning the conversion process.

Important!! Record a detailed description of all electrical changes made during the UCP695/starter retrofit process. Be sure to add a copy of this report to the chiller record file for future reference.

CVHE Applications with Wye-Delta Starters

The conversion procedure described here is divided into 2 parts—(1) component removal, and (2) starter rework. While it specifically applies to Wye-Delta starters, it can be adapted to successfully modify other types of starters for operation with a UCP695 panel.

Note: A typical, unit-mounted starter schematic-and-connection diagram appears in Figure 11. Be sure to refer to this diagram as you review the following instructions; the "preconversion" wire numbers and component designations indicated in these steps appear in Figure 11.

Removing Nonessential Starter Components

Note: To simplify future chiller trouble analysis, Trane recommends removing all existing, nonessential components from the starter panel enclosure.

1. Locate Fuses F1, F2, F3 and F4 in the starter panel. (See Figure 11.) Since the UCP assumes the functions performed by these fuses, remove them from the starter enclosure. To do this:
 - a. Disconnect Wire 113A from Fuse F1, Wire 113B from Fuse F2, Wires 113A,C from Fuse F3, and Wire 113B,D from Fuse F4.
 - b. Disconnect Wires 113C,D from the starter control power transformer (T1).
 - c. Remove all wires with a "113" prefix from the starter and discard them.
 - d. Disconnect Wire F1A from Fuse F1 and Terminal TB1-F1. Also, disconnect Wire F2A from F2 and TB1-F2, Wire F3A from F3 and TB1-F3, and Wire F4A from F4 and TB1-F4.
 - e. Remove Wires F1A, F2A, F3A and F4A from the starter and discard them.
 - f. Remove Fuses F1, F2, F3 and F4—and the fuse blocks—from the starter.

2. Since the protection afforded by circuit breakers CB11, CB15 and CB13 (Figure 11) is provided by the UCP's micro module, remove all 3 "breakers" from the starter. To do this:

a. Disconnect Wire 124A from CB11 and from the auxiliary contacts on K27. Then remove this wire from the starter and discard it.

b. Disconnect Wire 121A from CB15 and from K24; remove this wire from the starter and discard it.

c. Disconnect the following wires from the circuit breaker, contactor or solid-state overload (SSOL) terminal identified:

Wire 130A from CB11 and SSOL-E1;
Wire 131A from CB11 and SSOL-E2;
Wire 132A from CB15 and SSOL-E3;
Wire 133A from CB15 and SSOL-E4;

Shield of Wires 130/131 from SSOL-B2;
Shield of Wires 132/133 from SSOL-ground;

Wire 122A from CB15 and CB13;

Wire 123A from CB11 and CB13;
Wire 119A from CB13 and K24;
Wire 119B from K26 and K24; and,
Wire 2D from CB13 and K24.

Remove each of the wires just listed from the starter and discard it.

d. Remove circuit breakers CB11, CB15 and CB13 from the starter panel door.

3. Fabricate and install a cover plate over the openings left in the starter panel door when the breakers (and fuses, if applicable) were removed.

Figure 11
Typical Wye-Delta/CVHE Starter
Schematic and Connection Diagram
(Before UCP695 Conversion)

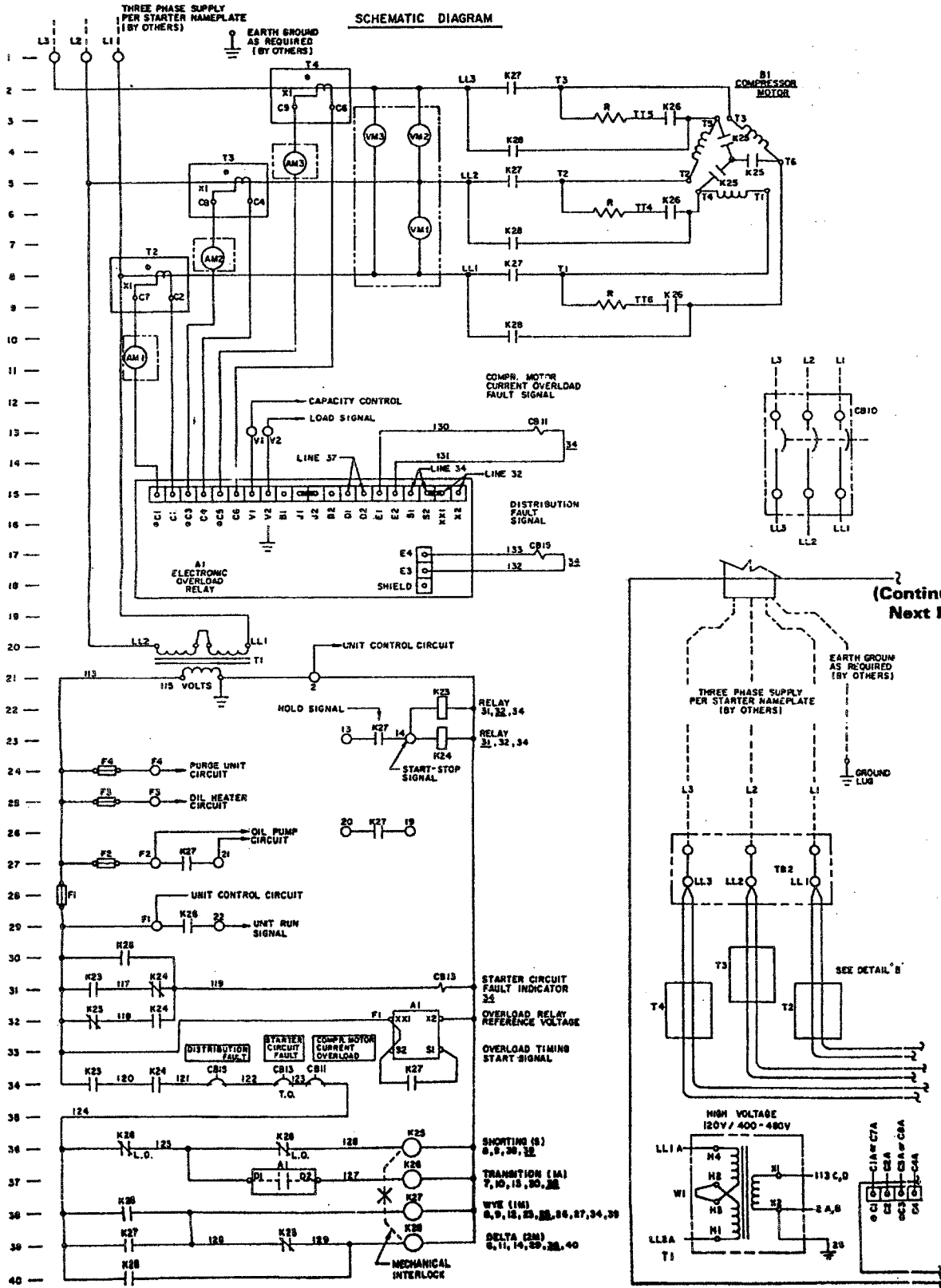

(Continued On Next Page)

CONNECTION DIAGRAM

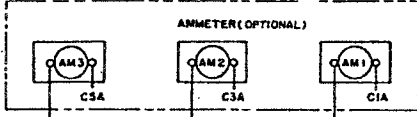
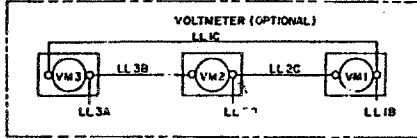
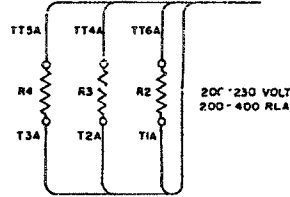
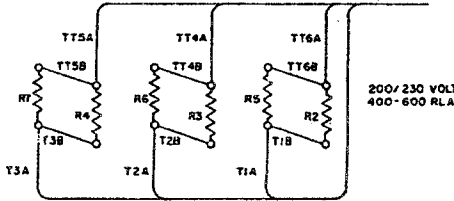
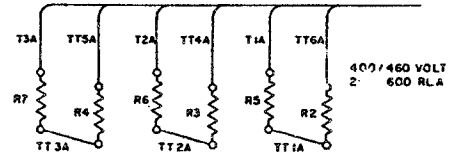
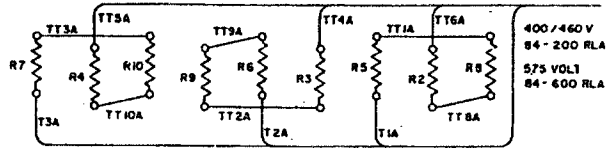
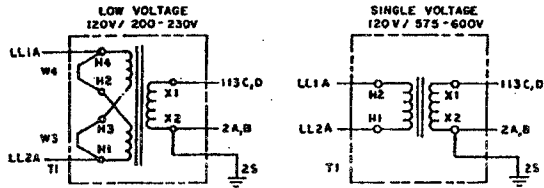
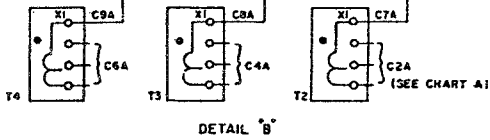
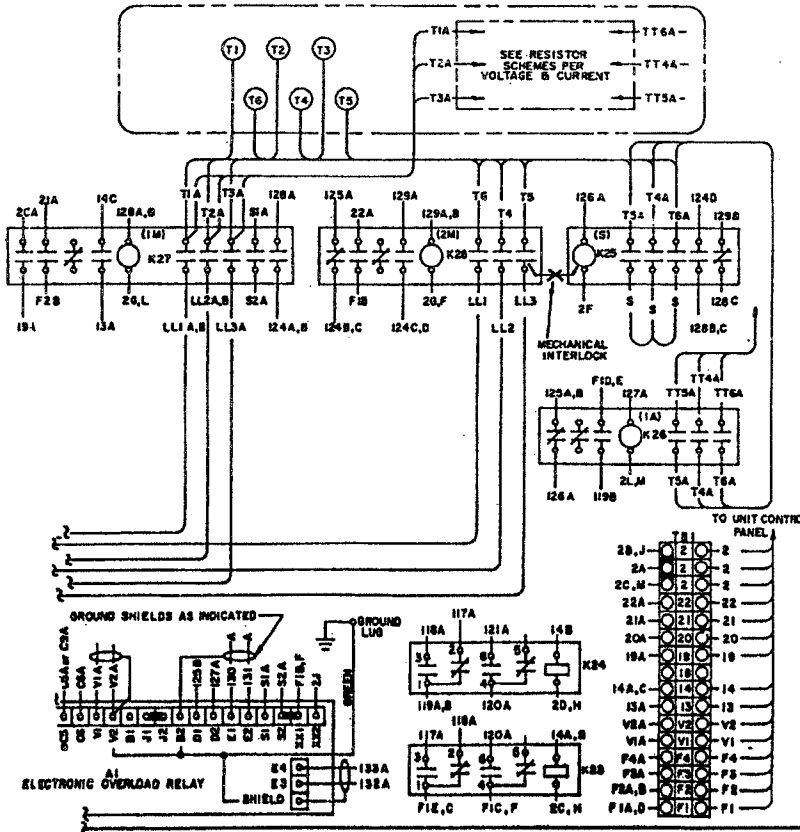

CHART A

CURRENT RANGE	TRANSFORMER CONNECTION
300	X1 TO X2
150	X1 TO X3
85	X1 TO X4
400	
200	
100	
500	
250	
125	
600	
300	
150	



(Continued From Previous Page)



WARNING
DISCONNECT ELECTRICAL POWER SOURCE TO PREVENT INJURY OR DEATH FROM ELECTRICAL SHOCK

CAUTION
Use copper conductors only to prevent equipment damage

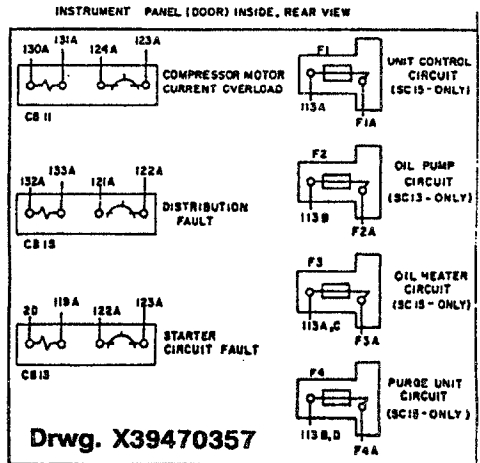

4. Since the functions performed by the SSOL (A1; Figure 11) are assumed by the UCP's micro module, remove the SSOL from the starter. To do this:

a. Disconnect the SSOL's green ground wire from the starter panel ground lug.

b. Disconnect Wires V1A and V2A—including the shield—from V1 and V2 on the SSOL, and from Terminals V1 and V2 on TB1. Remove both wires from the starter and discard them.

c. Disconnect Wire 2J from XX2 on the SSOL, and from Terminal 2 (the top one) on TB1. Remove Wire 2J from the starter and discard it.

d. Disconnect Wires F1B,F from SSOL Terminal XX1. Disconnect the opposite end of Wire F1F from contactor K23—and Wire F1B from the K28 auxiliary. Then remove both wires from the starter and discard them.

e. Disconnect Wires S1A and S2A from S1 and S2, respectively, on the SSOL, and from the auxiliary contacts on "start" contactor K27. Remove both wires from the starter and discard them.

f. Disconnect Wires 125B and 127A from SSOL Terminals D1 and D2, respectively. Disconnect the opposite end of Wire 125B from "transition" contactor K26—and Wire 127A from the K26 coil. Then remove both wires from the starter and discard them.

5. Both the K23 and K24 relays in the existing starter (Figure 11) duplicate the function performed by pilot relay 2K5 in the UCP695 control system. Relay K23 will serve as the pilot relay; to remove K24:

a. Wires 118A, 14B, 117A, 120A and 2H are each connected between Relays K23 and K24. Disconnect each of these wires from both relays; then remove these wires from the starter and discard them.

b. Remove the K24 relay from the starter panel enclosure and discard it.

c. Remove Wire F1C from Relay K23 and discard it. (It links the "common" sides of the K23 contacts.)

d. Disconnect Wire 14A from the coil of K23 and from Terminal TB1-14. Remove Wire 14A from the starter and discard it.

6. Six new current transformers—3 line CTs and 3 auxiliary CTs—are required to allow the starter to operate with the new UCP. Removal of the existing line CTs and wiring depends on whether or not the starter is equipped with ammeters—and how the ammeters will be powered.

Three variations in line CT installation are possible; these variations are listed below and described under "Starter Rework".

Option 1: New line CTs without ammeters;

Option 2: New line CTs with ammeters and new meter faceplates;

or,

Option 3: New line CTs with ammeters driven by existing line CTs.

If "Option 1" or "Option 2" is selected, remove—and discard—all of the wires connected between the SSOL, CTs and ammeters (if used). Then remove the existing CTs (T2, T3 and T4) from the starter, and go to Step 10.

If "Option 3" is selected, complete steps 7 through 9 before proceeding.

7. Remove the wires connected to SSOL Terminals C1 and C2, and splice them together.

8. Remove the wires connected to SSOL Terminals C3 and C4, and splice them together.

9. Remove the wires connected to SSOL Terminals C5 and C6, and splice them together.

10. Remove the 2 mounting screws that secure the SSOL to the starter back panel. Then remove the SSOL from the starter enclosure.

11. Remove the "extra" wires from "start" contactor K27:

a. Disconnect Wires 14C and 13A from K27's auxiliary contacts and from Terminals 14 and 13, respectively, on TB1.

b. Disconnect Wires 19A and 20A from K27 and from TB1-19 and -20, respectively.

Remove all 4 wires from the starter and discard them.

12. Remove the "extra" wires from "run" contactor K28. Disconnect:

a. Wire 22A from K28's normally-open auxiliary contacts and from TB1-22; and,

b. Wire 125A from K28's normally-closed auxiliary contacts and from "transition" contactor K26.

Remove both wires from the starter and discard them.

13. Remove the "extra" wires from "transition" contactor K26. Disconnect:

a. Wires F1D,E from K26's normally-open auxiliary contacts;

b. Wire F1E from K23;

c. Wire F1D from Terminal TB1-F1;

d. Wire 2M from the coil of K26 and from Terminal TB1-2.

Remove all 3 wires from the starter and discard them.

14. Disconnect Wires 2A,B from Terminal X2 on control power transformer T1, and from the top two TB1-2 terminals; see Figure 11. Remove Wires 2A,B from the starter and discard them.

Starter Rework

Important! Refer to the starter connection diagram in Figure 12 often as you rework the starter panel. All of the wire terminations you complete during the rework process should match this diagram.

After all nonessential starter components are removed from the starter enclosure, 3 wires should still be connected to the TB1 terminal strip: Wires 2C, 21A and F2B. (See Figure 11.)

Note: If additional wires are attached to TB1, check their termination points. If these wires are used to provide "special" starter features, determine whether or not these features can be incorporated into the reworked starter control scheme.

1. Complete Steps 1a through 1c to relabel Wires 2C, 21A and F2B appropriately.

a. Wire 2C is connected to TB1-2 and "pilot" relay K23. Relabel both ends of this wire as "2F"; then disconnect the end connected to TB1-2.

b. Wire 21A is connected between TB1-21 and a set of normally-open contacts on "start" contactor K27. Relabel both ends of this wire as "17D"; then disconnect the end connected to TB1-21.

c. Wire F2B is connected between TB1-F2 and a set of normally-open auxiliary contacts on "start" contactor K27. Relabel both ends of this wire as "18D"; then disconnect the end connected to TB1-F2.

2. Remove the existing TB1 terminal strip from the starter and install the new 2TB1 terminal strip (from the retrofit kit)—along with its accompanying terminal identification label—in its place.

3. Connect the wires relabelled in Steps 1a through 1c to the appropriate 2TB1 terminals. See Figure 12 for terminal designations and wire connections.

4. Relabel both ends of each of the wires listed below with the new wire number indicated:

a. Change Wire 2G to "2J". (It is connected between the "common" sides of the K27 and K28 contactor coils; see Figure 11.)

b. Change Wire 2F to "2K". (It is connected between the "common" sides of the K28 and K25 contactor coils.)

c. Change Wire 2L to "2H". (It is connected between the "common" sides of the K27 and K26 contactor coils.)

d. Change Wire 128A to "13C". (It connects K27 coil to a set of normally-open, auxiliary contacts on K27.)

e. Change Wire 128B to "13B". (It connects the K27 coil to a set of normally-open, auxiliary contacts on K25.)

f. Change Wire 128C to "13A". (It links the normally-open and normally-closed auxiliary contacts on K25.)

g. Change Wire 129B to "14A". (It connects the normally-closed, auxiliary K25 contacts to the coil of K28.)

h. Change Wire 129A to "14B". (It connects the K28 coil to a set of normally-open, auxiliary K28 contacts.)

i. Change Wire 124D to "9D". (It connects a normally-open set of auxiliary K25 contacts to a set of normally-open K28 auxiliary contacts.)

j. Change Wire 124C to "9C". (It links a normally-open set of auxiliary K28 contacts to a normally-closed set of K28 auxiliary contacts.)

k. Change Wire 124B to "9B". (It connects a normally-closed set of auxiliary K28 contacts to a normally-open set of auxiliary contacts on K27.)

l. Change Wire 126A to "11A". (It connects a normally-closed set of auxiliary K26 contacts to the K25 contactor coil.)

5. Relabel each of the existing starter panel components to match the electrical designations of the new UCP695 control system. "Old" to "new" designations are listed in Table 3.

6. Install the new line current transformers (CTs; 2T1, 2T2 and 2T3) with the mounting hardware provided.

Note: Recall that 3 variations in CT installation are possible:

Option 1: New line CTs without ammeters;

Option 2: New line CTs with ammeters and new meter faceplates; or,

Option 3: New line CTs with ammeters driven by existing line CTs.

If the existing CTs were removed from the starter (Option 1 or 2), install the new line CTs in their place. Be sure to replace the ammeter faceplates with ones that match the ratios of the new CTs, if applicable.

If the existing CTs will be retained to drive the ammeters (Option 3), install the new line CTs where space permits in the starter enclosure.

7. Install the 3 new auxiliary CTs (2T5, 2T6 and 2T7) near newly-installed terminal strip 2TB1; mounting hardware is provided.

8. Mount the "proof-of-transition" relay (provided) near 2TB1.

9. Install the fuse block and 30-amp, secondary starter fuse (2F4) in the starter panel enclosure.

10. Clearly label each of the components installed in Steps 6 through 9 with the appropriate electrical designation. (Refer to Table 3.)

Figure 12
Typical Connection Diagram for
Wye-Delta, Unit-Mounted Starter
Used w/UCP695 Control Panel

CHART A

CURRENT RATIO	TERMINALS
150:5	X1 TO X2
175:5	X1 TO X3
200:5	X1 TO X4
250:5	X1 TO X2
300:5	X1 TO X3
350:5	X1 TO X4
400:5	X1 TO X2
500:5	X1 TO X3
600:5	X1 TO X4
700:5	X1 TO X2
800:5	X1 TO X3
1000:5	X1 TO X4
1200:5	X1 TO X2
1500:5	X1 TO X3

NOTES

- 1 SEE DETAIL "A".
- 2 WIRES WHT AND BLK ARE UNSHIELDED CABLE.

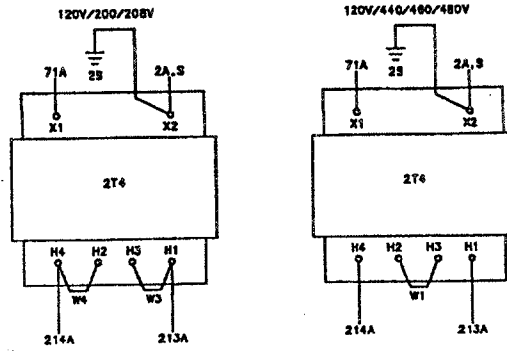
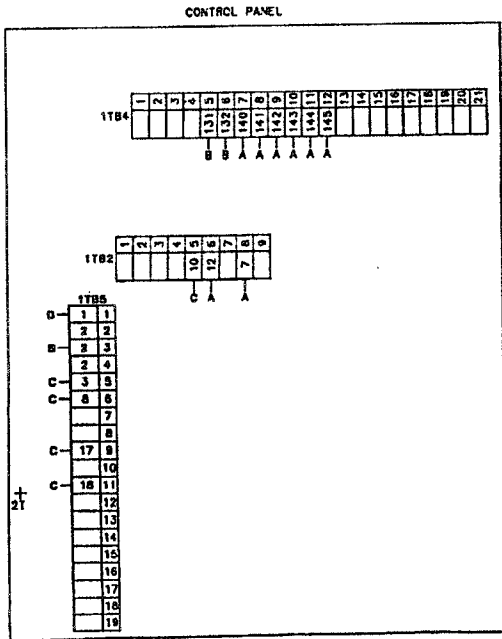
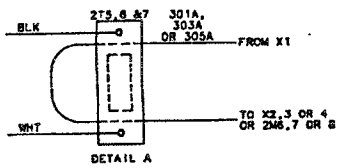

(Continued on next page)

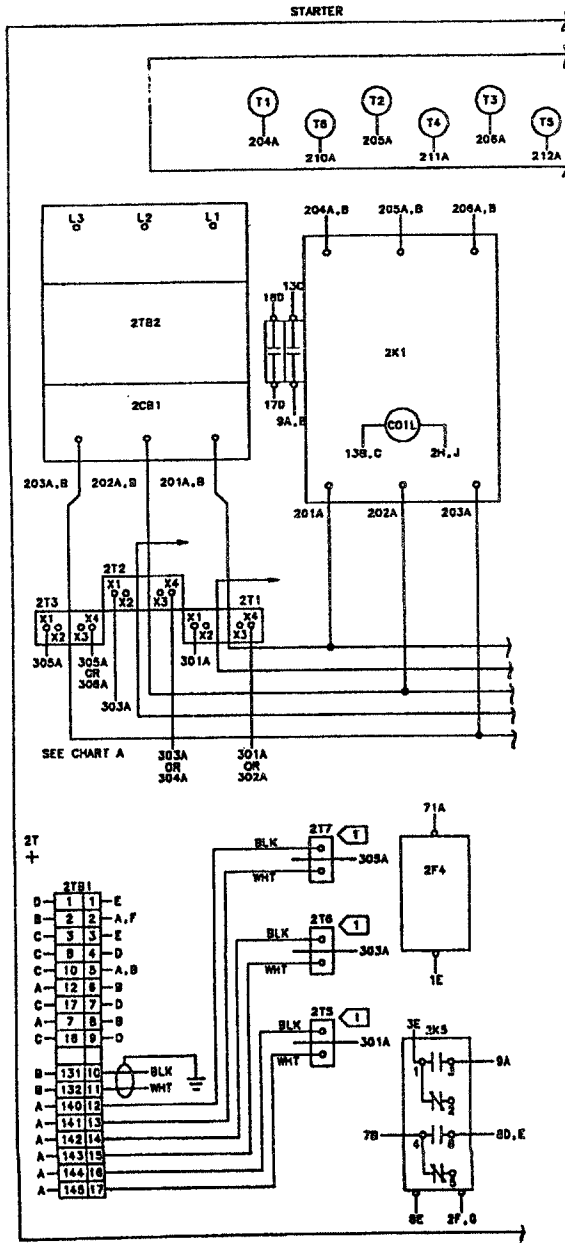

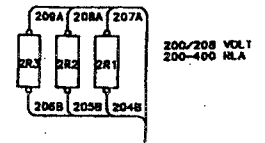
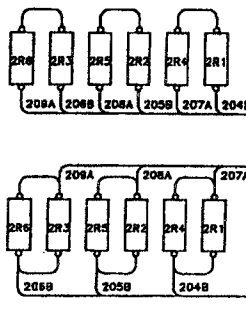
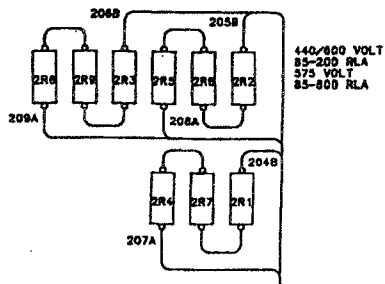

(Continued from previous page)

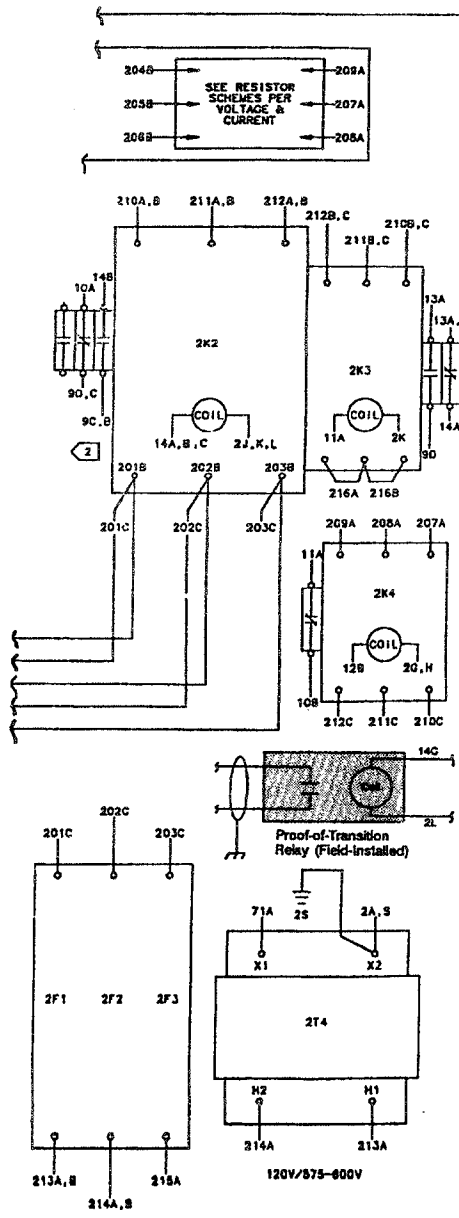

DOOR

WARNING
Disconnect electrical power supply to prevent injury or death due to electrical shock.

Caution
Use copper conductors only to prevent equipment damage (unless otherwise specified).

- Legend**
- 2CB1 Starter Circuit Breaker
 - 2F1 Phase 1 Primary Starter Fuse
 - 2F2 Phase 2 Primary Starter Fuse
 - 2F3 Phase 3 Primary Starter Fuse
 - 2F4 Secondary Starter Fuse
 - 2K1 Start Contactor
 - 2K2 Run Contactor
 - 2K3 Shorting Contactor
 - 2K4 Transition Contactor
 - 2K5 Pilot Relay
 - 2R1-9 Transition Resistors
 - 2T1 Phase 1 Line CT
 - 2T2 Phase 2 Line CT
 - 2T3 Phase 3 Line CT
 - 2T4 Control Power Transformer
 - 2T5 Phase 1 Auxiliary CT
 - 2T6 Phase 2 Auxiliary CT
 - 2T7 Phase 3 Auxiliary CT
 - 2TB1 Control Terminal Block
 - 2TB2 Line Terminal Block

Drwg. X39470405D

Complete the 120-volt electrical wire additions described in Steps 11 through 24 (and indicated in Figure 12). To simplify the match up of wire type and color, you may want to reuse some of the wires removed from the starter.

11. Route a 10-gauge wire from Terminal 2TB1-1 to the 2F4 fuse block, and label it "1E" at both ends.

12. Route a 10-gauge wire from 2F4 to Terminal X1 on control power transformer 2T4. Label both ends of this wire "71A".

13. Run a 10-gauge wire from Terminal 2TB1-2 to the X2 terminal of 2T4, and label it "2A" at both ends.

14. Verify that a wire labelled "2S" is connected between 2T4-X2 and ground.

15. Route a 14-gauge wire between Terminal 2TB1-3 and Terminal 1 on pilot relay 2K5. Label both ends of this wire "3E".

16. Route a 14-gauge wire from Terminal 3 on 2K5 to the set of normally-open 2K1 auxiliary contacts with Wire 13C attached. Label both ends of this wire "9A".

17. Route a 14-gauge wire between Terminal 2TB1-4 and Terminal 6 on relay 2K5. Label both ends of this wire "8D".

**Table 3
Starter Panel
Component Electrical Designations**

Starter Panel Component	Electrical Designation	
	Before UCP Conversion (Figure 11)	After UCP Conversion (Figure 12)
Line Terminal Block or Circuit Breaker, Optional	TB2 CB10	2TB2 2CB1
Line Current Transformers	T2, T3, T4	2T1, 2T2, 2T3
Auxiliary Current Transformer	n/a	2T5, 2T6, 2T7
Transition Resistors	R2, R3, R4, R5, R6, R7, R8, R9 and R10	2R1, 2R2, 2R3, 2R4, 2R5, 2R6, 2R7, 2R8 and 2R9
Control Power Transformer	T1	2T4
Solid-State Overload	A1	n/a
Primary Starter Fuses, Optional	n/a	2F1, 2F2, 2F3
Secondary, 30-Amp Starter Fuse	n/a	2F4
"Start" Contactor (also "Wye", or "1M")	K27	2K1
"Run" Contactor (also "Delta", or "2M")	K28	2K2
"Shorting" Contactor (also "S")	K25	2K3
"Transition" Contactor (also "1A")	K26	2K4
"Pilot" Relays	K23, K24	2K5
"Proof-of-Transition" Relay	n/a	2K2 auxiliary**
Control Terminal Block	TB1	2TB1
Voltmeters, Optional	VM1, VM2, VM3	2M3, 2M4, 2M5
Ammeters, Optional	AM1, AM2, AM3	2M6, 2M7, 2M8

**While the "proof-of-transition" relay is typically a set of normally-open, auxiliary 2K2 contacts on UCP695 production units, a separate relay must be added to the existing starter panel when a chiller is retrofitted with a UCP695 control system.

18. Route a 14-gauge wire from Terminal 2TB1-5 to the normally-closed set of auxiliary 2K2 contacts with Wires 9C,D attached. Label both ends of this wire "10A".

Note: The wires connected to the "common" side of 2K2's normally-closed (NC) auxiliary contacts may be "9C,B" rather than "9C,D", depending on how the starter was originally wired. In either case, verify that Wire 10A is connected to the line side of 2K2's NC auxiliary contacts, and that Wire 14B is connected to the line side of 2K2's NO auxiliary contacts.

19. Route another 14-gauge wire from Terminal 2TB1-5 to the normally-closed set of 2K4 auxiliary contacts with Wire 11A attached. Label both ends of this wire "10B".

20. Run a 14-gauge wire between Terminal 2TB1-6 and the coil of contactor 2K4 (i.e., opposite the coil connection with Wire 2H attached). Label both ends of this wire "12B".

21. Run a 14-gauge wire from Terminal 2TB1-8 to Terminal 4 on 2K5. Label both ends of this wire "7B".

22. Route a 14-gauge wire from the coil of 2K5 (i.e., the side with Wire 2F attached) to the coil of contactor 2K4 (i.e., the side with Wire 2H attached). Label both ends of this wire "2G".

23. Route a 14-gauge wire from the coil of 2K5 (i.e., the coil connection opposite Wires 2F,G) to Terminal 6 on 2K5. Label both ends of this wire "8E".

24. Run a pair of 14-gauge wires—labeled "14C" and "2L" at both ends—from the coil of the "proof-of-transition" relay to the coil of "run" contactor 2K2. See Figure 13.

Complete the <30-volt electrical wire additions described in Steps 25 and 26 (and shown in Figure 12).

Caution: To ensure that electrical noise does not distort the signals carried by the low-voltage wiring, maintain at least 6" between low-voltage (<30 V) and 115 V circuits!

25. Route a twisted, shielded pair of 14 to 18-gauge, 800V wire from the normally-open "proof-of-transition" relay contacts to 2TB1. Then:

a. Connect the white lead (WHT) to Terminal 2TB1-11.

b. Connect the black lead (BLK) to Terminal 2TB1-10.

c. Ground the shield wire to one of the mounting screws that secures 2TB1 to the starter back panel.

d. Tape off the opposite end of the shield wire at the "proof-of-transition" relay.

26. Route a pair of wires from each auxiliary CT (2T5, 2T6 and 2T7) to 2TB1; Figure 12 illustrates the appropriate terminal connections for each auxiliary CT.

Though it is not required, twisted, shielded-pair wire may be used for these connections; just be sure to tape off the shield wire at both ends of each run.

Note: To assure that the UCP receives accurate CT inputs, all CT electrical connections must maintain proper polarity and phasing. See Figure 12.

27. Run wire for each of the line CTs (2T1, 2T2 and 2T3); the resulting circuits should match one of the 3 alternative configurations shown in Figure 14. Table 4 lists the appropriate line CT electrical connections for various RLA values and CT ratios.

Note: If the existing line CTs and wiring were retained to drive the ammeters (Option 3), make sure that your CT wiring connections match those shown in Figure 14.

Figure 13
"Proof-of-Transition" Relay
Electrical Connections

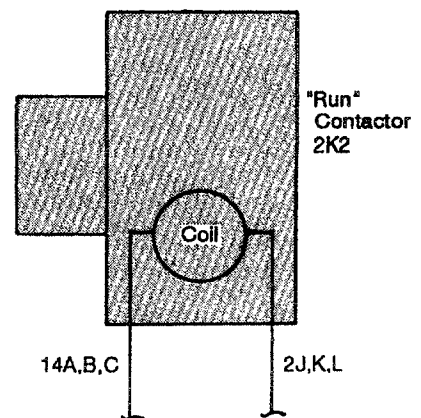
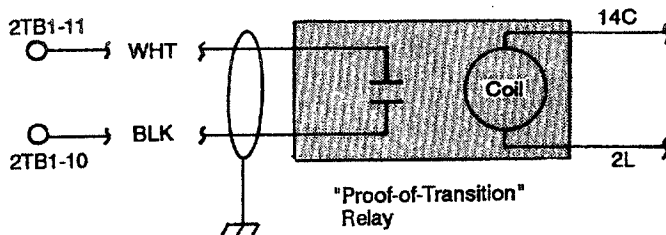

Notes:

1. RLY-847 is provided with the CVRA panel conversion kit for proof of transition.
2. The "transition complete" input circuit (i.e., Terminals 2TB1-10 and -11) is less than 30 volts; use shielded cable since this circuit is run between the relay contacts and terminal strip within the starter panel enclosure.

Figure 14
Current Transformer
Connections

Legend

- 2T1 Phase 1 Line CT
- 2T2 Phase 2 Line CT
- 2T3 Phase 3 Line CT

- 2T5 Phase 1 Auxiliary CT
- 2T6 Phase 2 Auxiliary CT
- 2T7 Phase 3 Auxiliary CT

- 2M6 Phase 1 Opt. Ammeter
- 2M7 Phase 2 Opt. Ammeter
- 2M8 Phase 3 Opt. Ammeter

WARNING
 Disconnect electrical power supply to prevent injury or death due to electrical shock.

Caution
 Use copper conductors only to prevent equipment damage (unless otherwise specified).

Option 1:
New Line CTs
w/o Ammeters

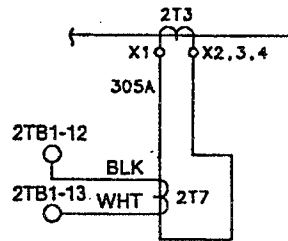
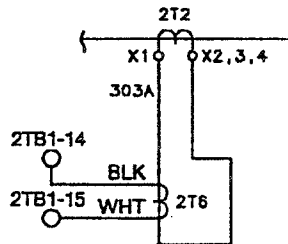
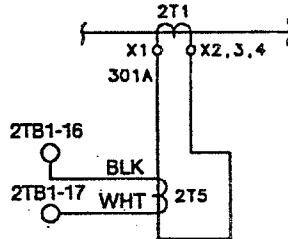

Option 2:
New Line CTs w/Ammeters
(and New Meter Faceplates)

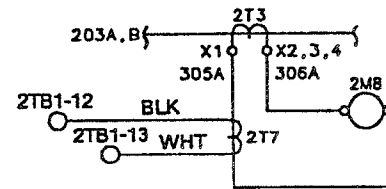
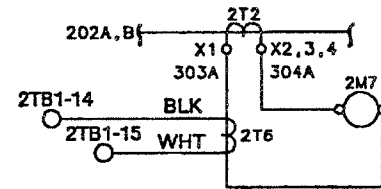
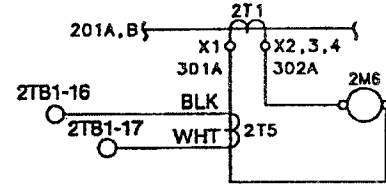

Option 3:
New Line CTs w/Existing
Line CTs Retained for Ammeters

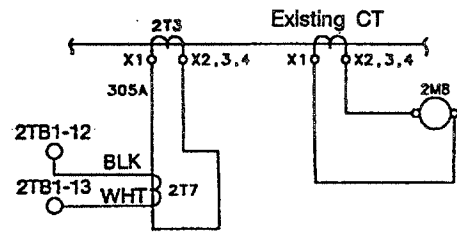
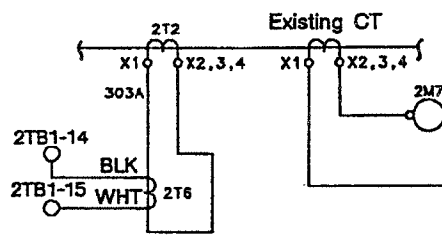
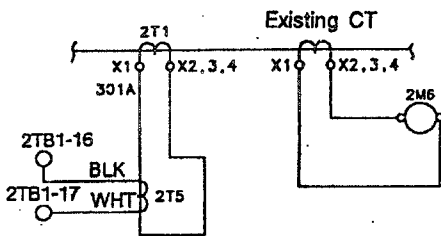

Drwg. X39470454B

Table 4
Terminal Connections for
Line Current Transformers (CTs)

Line CT Part No.	Line CT Ratio	CT Terminal Connections	No. of Primary Turns	RLA Range(s)
X13580048-01	150 : 5	X1 to X2	3	28.6 to 35.7
			2	42.9 to 53.5
			1	89.3 to 107.1
	180 : 5	X1 to X3	3	35.8 to 42.8
			2	53.6 to 64.2
			1	107.2 to 128.5
	200 : 5	X1 to X4	2	64.2 to 71.4
			1	128.6 to 142.8
	X13580048-02	250 : 5	X1 to X2	2
1				142.9 to 178.5
300 : 5		X1 to X3	1	178.6 to 214.2
			350 : 5	X1 to X4
X13580048-03	400 : 5	X1 to X2	1	
	500 : 5	X1 to X3	1	285.8 to 357.1
	600 : 5	X1 to X4	1	357.2 to 428.5
X13580048-04	700 : 5	X1 to X2	1	428.6 to 500.0
	800 : 5	X1 to X3	1	500.1 to 571.4
	1000 : 5*	X1 to X4	1	571.5 to 714.2
X13580048-05	1200 : 5*	X1 to X2	1	714.3 to 857.1
	1500 : 5*	X1 to X3	1	857.2 to 1071.4
X13580047-01	1800 : 5	X1 to X2	1	1071.5 to 1285.7
	2100 : 5	X1 to X3	1	1285.8 to 1500.0
	2500 : 5	X1 to X4	1	1500.1 to 1785.7

*If the 2.5"-diameter holes in these CTs is not large enough, CTs with 4.0"-diameter holes (part no. X13580047-02) are available for each of these CT ratios (i.e., 1000:5, 1200:5 and 1500:5).

28. Run new wiring from the line CTs through the auxiliary CTs and back to the line CTs. In each instance, the wire should:

a. be one continuous loop without splices (unless the new line CTs are used to drive ammeters); and,

b. make only 1 pass through the auxiliary CT. See Figure 15. **Do not make more than 1 pass through the auxiliary CTs!**

Pay special attention to the polarity of the CT wiring; make sure that loop direction is consistent from one CT to the next. (Refer to the appropriate CT wiring configuration in Figure 14 to determine polarity and wire numbers.)

Note: The polarity of each auxiliary CT is determined by which side the black and white wires emerge from the CT.

29. Recheck the termination points of each line CT wire pair that passes through the auxiliary CTs. Each should terminate at the appropriate secondary tap on the line CT. (See Figure 14.)

30. Using Table 5, Figure 16 and the wiring diagrams that shipped with the UCP retrofit kit, complete the electrical connections between the starter and the UCP695 control panel.

a. Before connecting any external wiring to the UCP, check all wires to ensure that they are not grounded!

b. Verify that none of the 120V control circuits are routed to the low-voltage (upper) section of the UCP.

Caution: Connecting a 120V control circuit to the low-voltage section of the UCP will destroy micro module 1U3!

* * * * *

Use the guidelines outlined below to ensure that the starter-to-UCP interconnections are completed correctly:

(1) Use the existing starter-to-panel conduit for the 120V circuits.

(2) Install a second conduit (field-supplied) between the low-voltage (<30V) section of the UCP and the starter.

(3) The 120V starter-to-UCP conduit should contain 9 wires: 2 #10 AWG, 600V wires, and 7 #14 AWG, 600V wires.

(4) The <30V starter-to-UCP conduit should contain 8 #14 (or #16) AWG, 600V wires. Use #16 AWG wire when the distance—one way—is 250 feet or less; if this distance is 400 feet or less, use #14 AWG wire.

Figure 15
Line CT Wire Loop
through Auxiliary CT

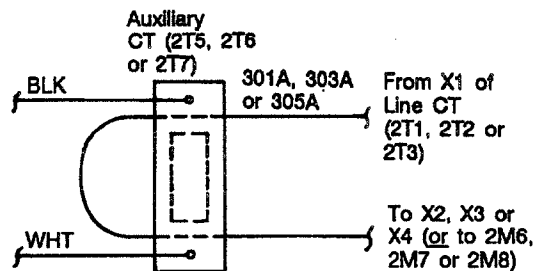

**Table 5
Field Wiring Requirements
between UCP695 Panel and
Starter Panel (1)**

UCP695 Control Panel		Inter-Connecting Wire No. (2)	Starter Panel	
115-Volt Ckt. Descriptions	Terminal		Terminal	115-Volt Ckt. Descriptions
115 VAC Power Supply (from starter panel)	1TB5- 1	1	2TB1- 1	115 VAC Power Supply (to UCP695 Panel)
115 VAC Common (from starter panel)	1TB5- 2	2	2TB1- 2	115 VAC Common
Compressor Start Relay (1U2K4)	1TB5- 5	3	2TB1- 3	Control Circuit Power (N.O. pilot relay (2K5) contacts in 2K3 shorting contactor ckt.)
"Start" Signal Sent to Starter (hour/start meter ckts.)	1TB5- 6	8	2TB1- 4	"Start" Signal from UCP695 (2K5 pilot relay coil ckt.)
"Transition" Signal Sent to Starter (1U2K5 transition relay ckt.)	1TB2- 5 1TB2- 6	10 12	2TB1- 5 2TB1- 6	"Transition" Signal from UCP695 (2K4 transition contactor ckt.)
Oil Pump Relay Ckt. (1U2K7)	1TB5- 9 1TB5-11	17 18	2TB1- 7 2TB1- 9	Auxiliary 2K2 Start Contactor Contacts (oil pump ckt.)
"Run" Signal Sent to Starter (2K5 pilot relay "holding" ckt.)	1TB2- 8	7	2TB1- 8	"Run" Signal from UCP695 (2K5 pilot relay "holding" ckt.)
<30-Volt Ckt. Descriptions (4)	Terminal	Wire No. (3)	Terminal	<30-Volt Ckt. Descriptions
"Transition Complete" Signal from Starter	1TB4- 5 1TB4- 6	131 132	2TB1-10 2TB1-11	"Transition Complete" Signal Sent to UCP695 (auxiliary 2K2 run contactor contacts in "proof-of-transition" ckt.)
2T7 Auxiliary CT Input from Starter	1TB4- 7 1TB4- 8	140 141	2TB1-12 2TB1-13	2T7 Auxiliary CT Output to UCP695
2T6 Auxiliary CT Input from Starter	1TB4- 9 1TB4-10	142 143	2TB1-14 2TB1-15	2T6 Auxiliary CT Output to UCP695
2T5 Auxiliary CT Input from Starter	1TB4-11 1TB4-12	144 145	2TB1-16 2TB1-17	2T5 Auxiliary CT Output to UCP695

Notes:

1. Be sure to separate 115 VAC wiring (i.e., Terminals 2TB1-1 thru -9) from low-voltage wiring (i.e., less than 30 volts; Terminals 2TB1-10 thru -17) both inside and outside of the starter panel. Use the wiring ducts provided in the panel conversion kit for this purpose.

Caution: To prevent electrical noise interference, ensure that low-voltage (i.e., less than 30 volts) wiring is always at least 6" from high-voltage (i.e., 115 VAC and higher) wiring.

2. Use #14 AWG, 600V wire for the indicated 115-volt circuits.
3. Use #14 to #18 AWG, 600V wire for the indicated "<30-volt" circuits. Do not run any of these wires in conduit with higher voltage wires!
4. Check the wire connections at 1TB4 for tightness at least 24 hours after installing them. (Since this terminal strip is constructed of plastic, connections made at any of its terminals may loosen with time.)

Figure 16
UCP695 Field Wiring Connections
(Remote-Mounted Starter Applications)

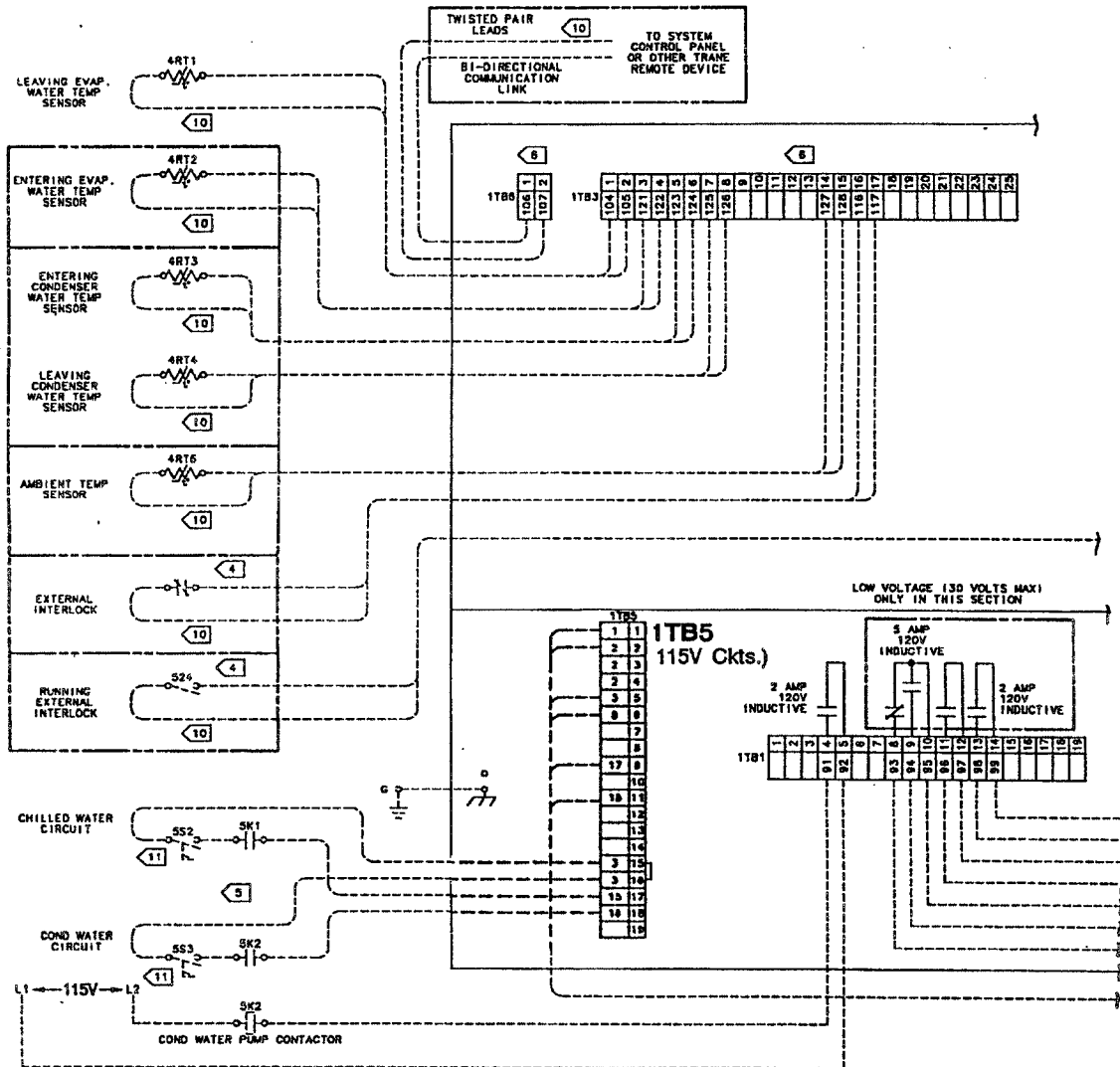

WARNING
 Disconnect electrical power supply to prevent injury or death due to electrical shock.

Caution
 Use copper conductors only to prevent equipment damage (unless otherwise specified).

(Continued On Next Page)

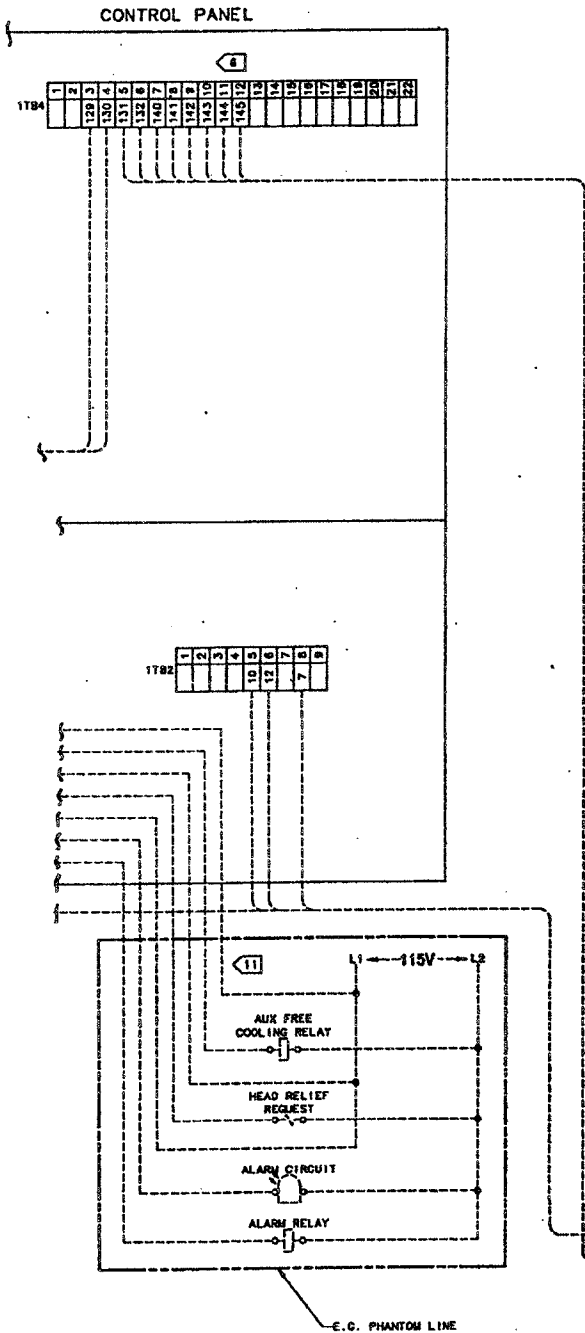

(Continued From Previous Page)

CUSTOMER NOTE:

1. DASHED LINES INDICATE RECOMMENDED FIELD WIRING BY OTHERS. PHANTOM LINES INDICATE ALTERNATE CIRCUITRY OR AVAILABLE SALES OPTION. CHECK SALES ORDER TO DETERMINE IF WIRING IS REQUIRED FOR SPECIFIC OPTIONS.
2. ALL FIELD WIRING MUST BE IN ACCORDANCE WITH THE NATIONAL ELECTRICAL CODE (NEC), STATE AND LOCAL REQUIREMENTS. OTHER COUNTRIES APPLICABLE NATIONAL AND/OR LOCAL REQUIREMENTS SHALL APPLY.
3. CONTROL VOLTAGE WIRING (120 VAC) TERMINALS 1 THRU 9 AND LOW VOLTAGE WIRING (30 VOLTS MAX) TERMINALS 10 THRU 17 MUST BE KEPT SEPARATE BOTH INSIDE OF STARTER AND IN RUNS TO CONTROL PANEL.
4. CUSTOMER SUPPLIED CONTACTS MUST BE COMPATIBLE WITH DRY CIRCUIT 12 VDC, 45 mA. GOLD PLATED CONTACTS RECOMMENDED.
5. RECOMMENDED CIRCUIT; COMPONENTS SUPPLIED BY OTHERS, 5K1 & 5K2 ARE AUX CONTACTS ON PUMP STARTERS; 5S2 & 5S3 ARE FLOW SWITCHES IN APPROPRIATE WATER CIRCUITS.
6. RETIGHTEN TERMINALS A MINIMUM OF 24 HOURS AFTER INITIAL INSTALLATION. DO NOT OVER TIGHTEN.
7. BUS BARS NOT INCLUDED - MUST BE ORDERED SEPARATELY.
8. COPPER WIRE, SIZED PER N.E.C., BASED ON UNIT NAMEPLATE RLA PLUS TRANSFORMER LOAD IN L1 & L2. PHASING OF 3 PHASE INPUT; L1 TO A, L2 TO B, L3 TO C WHERE ABC REPRESENTS STANDARD PHASE ROTATION.
9. COPPER WIRE ONLY, SIZED PER N.E.C., BASED ON NAMEPLATE RLA.
10. 30V OR LESS #14-18 AWG 600V WIRE. DO NOT RUN IN CONDUIT WITH HIGHER VOLTAGE WIRE.
11. 120V AC, #14 AWG 600V WIRE.

Drwg. X39470501A

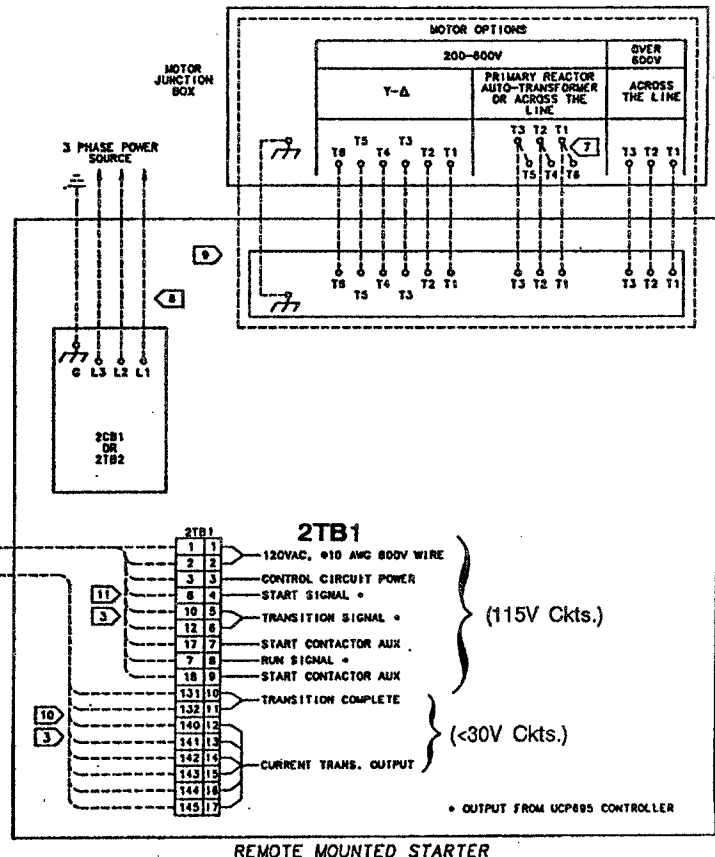

REMOTE MOUNTED STARTER

Non-Wye-Delta Starters

Modifying an existing closed-transition starter for compatibility with the UCP695 panel requires a process similar to the one just described under "CVHE Applications with Wye-Delta Starters". However, several additional changes may be required.

Each of these extra modifications are described below. Use this information—along with the instructions provided for CVHE/Wye-Delta applications—to adapt the existing starter panel to the UCP695 control system.

Note: Only the "proof-of-transition" relay is included in the UCP695 conversion package; all other relays required for starter panel conversion must be purchased locally.

Control Power Transformer (2T4)

If the existing starter does not have 115V/3KVA of additional control power, install a transformer (field-supplied) that will provide 115 VAC to the UCP695 control panel. (As just described, transformer requirements are: line-voltage primary/115V secondary, minimum capacity 3KVA.)

"Pilot" Relay (2K5)/UCP695 Interface

Figure 17 illustrates the recommended electrical interface between the "pilot" start relay in the starter panel and the UCP695 control panel when control voltage is not 115 VAC.

Starter Transition

The UCP695 control panel initiates transition when motor current draw falls to 85% of RLA. At that time, a set of contacts in the control panel's power supply output module (1U2; between Terminals 1TB2-5 and -6) closes to initiate the starter's transition sequence.

If the starter panel's chiller control circuit is not 115 VAC, a field-supplied relay must be installed to isolate the higher starter control voltage from the UCP695 panel. See Figure 18.

Note: If desired, starter panels with both K23 and K24 interrupting circuit protection can be wired to take advantage of both relays; this offers additional starter protection from contact welding.

Figure 17
Start Relay Interface
(See Note 1)

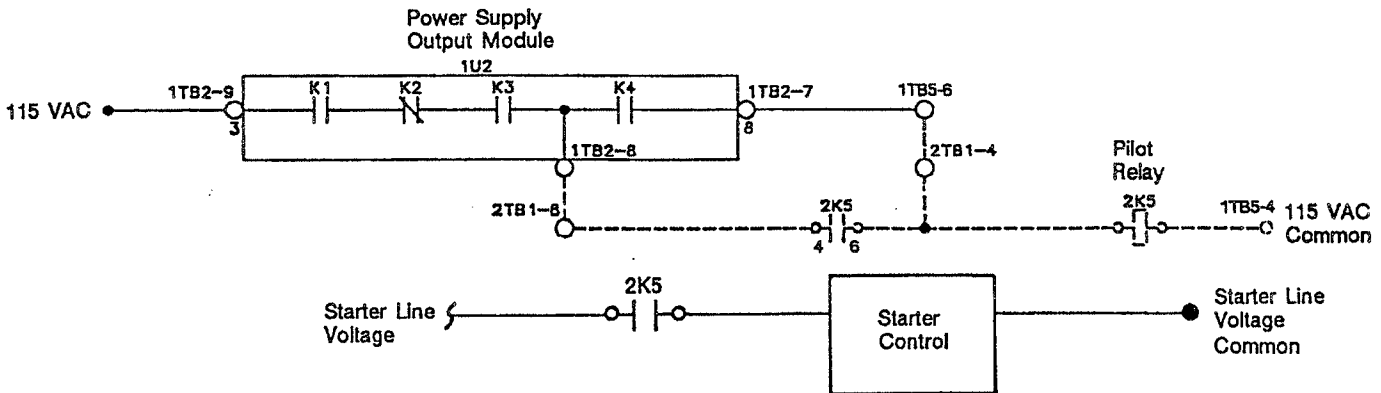

WARNING
Disconnect electrical power supply to prevent injury or death due to electrical shock.

Caution
Use copper conductors only to prevent equipment damage (unless otherwise specified).

Notes:

1. This schematic illustrates the recommended start relay interface between the UCP695 control panel and the starter panel when starter control voltage is not 115 VAC.
2. Relay coils for K1 (reset relay), K2 (stop relay), K3 (overload relay) and K4 (compressor start relay) are not shown since contact closure is governed by micro module (1U3) control logic.

Figure 18
Starter Transition Interface
 (See Note 1)

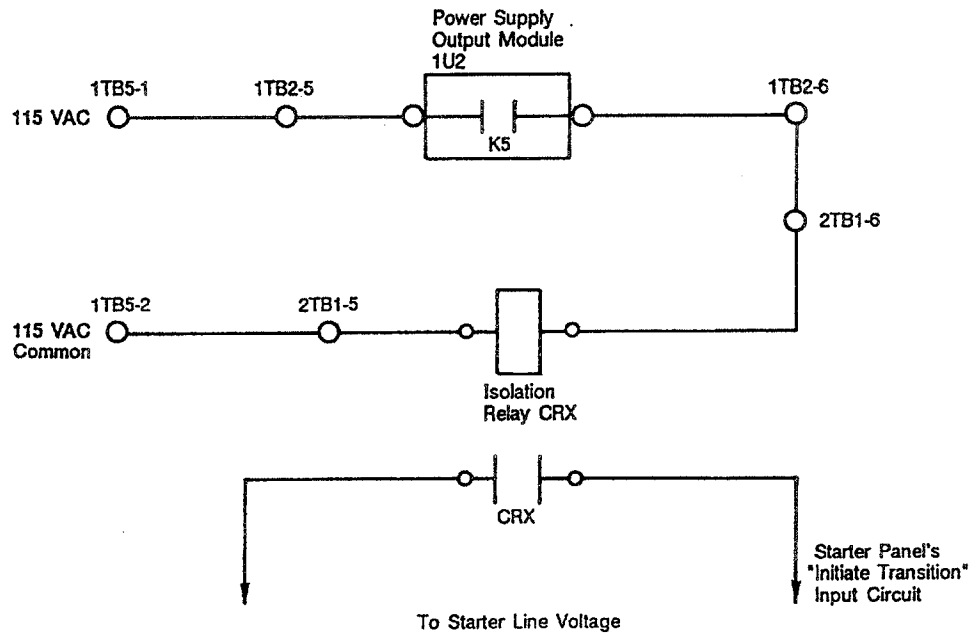

WARNING
 Disconnect electrical power supply to prevent injury or death due to electrical shock.

Caution
 Use copper conductors only to prevent equipment damage (unless otherwise specified).

Notes:

1. An "isolation" relay (CRX) must be installed as shown whenever the existing starter control circuit is not 115 VAC.
2. "Isolation" relay CRX must be rated for line voltage, and mounted within the starter panel enclosure.
3. Compressor transition relay K5's coil is not shown since contact closure is governed by micro module (1U3) control logic.

Proof of Transition

Regardless of starter type, micro module 1U3 in the UCP695 control panel must always "prove" that the starter panel completed its transition sequence. In other words, any reduced voltage start-up requires proof that the 2M (2K2) contacts, or equivalent, have closed.

Install the "proof-of-transition" relay provided with the UCP695 conversion package as shown in Figure 13.

Caution: To avoid damaging micro module 1U3, do not substitute a contactor auxiliary for the "proof-of-transition" relay! Remember that the "proof-of-transition" circuit is low-voltage (less than 30V).

Starter Control "Extras"

Any alarm circuits or other auxiliary control devices under starter panel control not already discussed in this manual must remain under starter control!

For your reference, Figures 19, 20 and 21 illustrate the electrical schematics for UCP695-compatible across-the-line, primary reactor, and autotransformer starters.

Note: Notice that across-the-line starters (Figure 19), with their single start contactor, do not require a transition or proof-of-transition contactor closure to operate safely. However, the UCP695 panel does require these signals to verify a proper start sequence! To provide the UCP with these inputs in an across-the-line starter application, connect the relay normally used for "proof of closure" (2K3) as illustrated in Figure 19.

Figure 19
Typical Schematic
for UCP695-Compatible,
Across-the-Line Starters

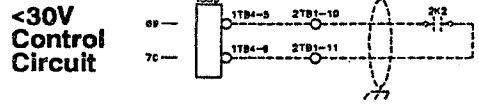
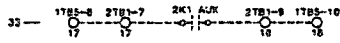
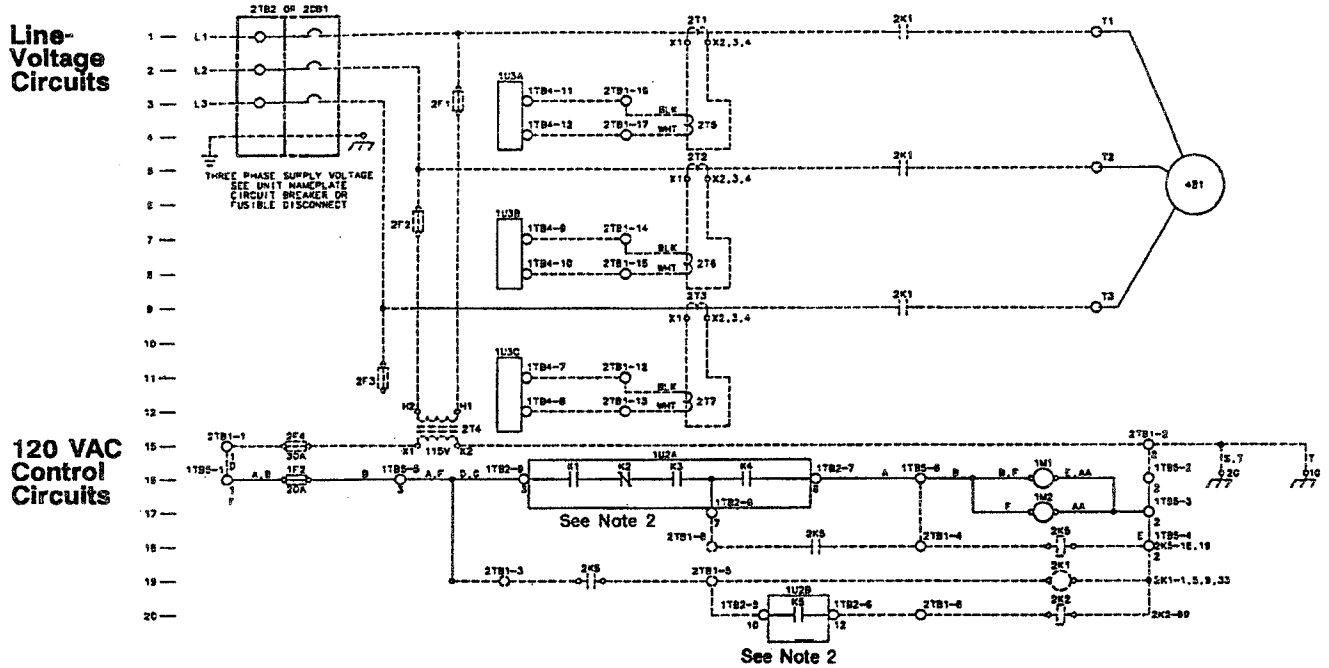

Legend

- Unit Control Panel Devices**
- 1F2 Branch Circuit Fuse
 - 1M1 Hour Meter
 - 1M2 Start Meter
 - 1U2A-D Power Supply Output Module
 - 1U2K1 Reset Relay
 - 1U2K2 Stop Relay
 - 1U2K3 Overload Relay
 - 1U2K4 Compressor Start Relay
 - 1U2K5 Compressor Transition Relay
 - 1U3A-D Micro Module

- Starter Panel Devices**
- 2CB1 Starter Circuit Breaker
 - 2F1-3 Primary Starter Fuse(s)
 - 2F4 Secondary Starter Fuse
 - 2K1 Start Contactor
 - 2K2 Run Contactor
 - 2K5 Pilot Relay
 - 2T1-3 Line CTs
 - 2T4 Control Power Transformer
 - 2T5-7 Auxiliary CTs
 - 2TB1 Control Terminal Block
 - 2TB2 Line Terminal Block

WARNING
 Disconnect electrical power supply to prevent injury or death due to electrical shock.

Caution
 Unless otherwise specified, use only copper conductors to prevent equipment damage.

Notes:
 1. While across-the-line starters do not require a transition or proof-of-transition contact closure to operate safely, the UCP695 panel does need these signals to verify that a proper start sequence occurred.

When adapting an existing across-the-line starter for UCP695 compatibility, keep in mind that the auxiliary contacts normally supplied on contactors are not compatible with the "transition complete" circuit. Use RLY-847 (provided) between the auxiliary contacts and Terminals 2TB1-10 and -11 to ensure compatibility of the contact material.

2. Relay coils for 1U2K1 through 1U2K5 are not shown since the contacts are controlled by micro module (1U3) logic.

Drwg. X39470503A

Figure 20
Typical Schematic
for UCP695-Compatible,
Primary Reactor/Primary Resistor
Starters

Line-Voltage
Circuits

120 VAC
Control
Circuits

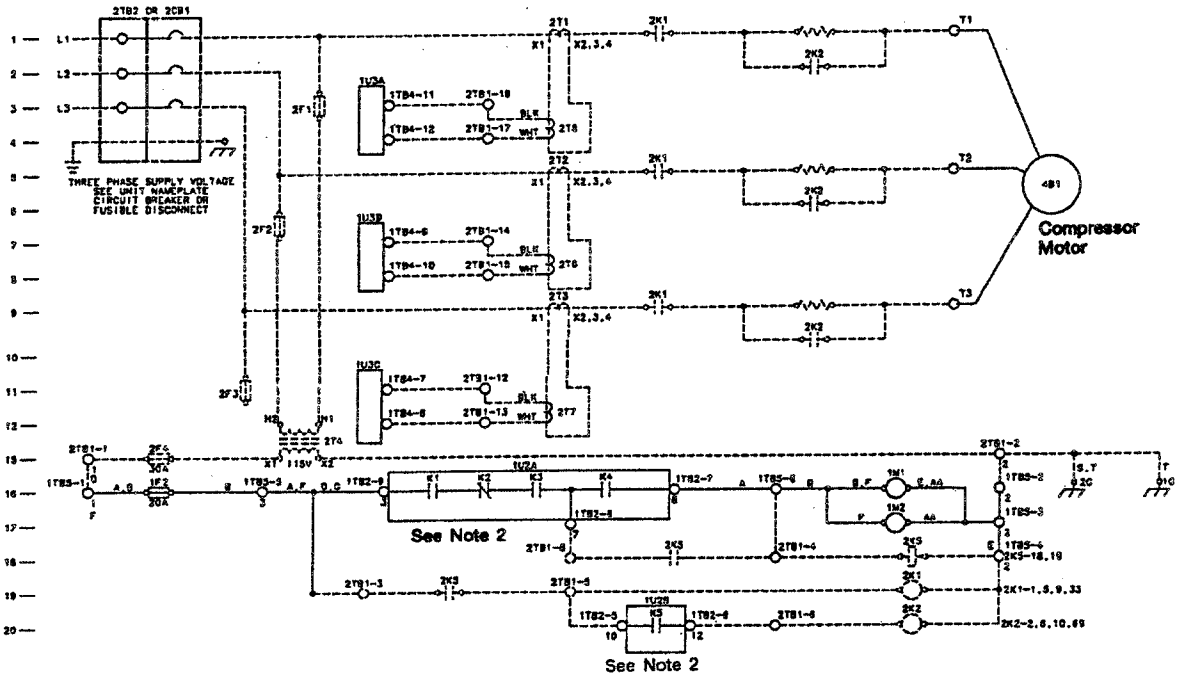

<30V
Control
Circuit

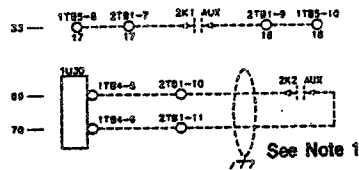

Legend

Unit Control Panel Devices

- 1F2 Branch Circuit Fuse
- 1M1 Hour Meter
- 1M2 Start Meter
- 1U2A-D Power Supply Output Module
- 1U2K1 Reset Relay
- 1U2K2 Stop Relay
- 1U2K3 Overload Relay
- 1U2K4 Compressor Start Relay
- 1U2K5 Compressor Transition Relay
- 1U3A-D Micro Module

Starter Panel Devices

- 2CB1 Starter Circuit Breaker
- 2F1-3 Primary Starter Fuse(s)
- 2F4 Secondary Starter Fuse
- 2K1 Start Contactor
- 2K2 Run Contactor
- 2K5 Pilot Relay
- 2T1-3 Line CTs
- 2T4 Control Power Transformer
- 2T5-7 Auxiliary CTs
- 2TB1 Control Terminal Block
- 2TB2 Line Terminal Block

WARNING
Disconnect electrical
power supply to prevent
injury or death due to
electrical shock.

Caution
Unless otherwise
specified, use only copper
conductors to prevent
equipment damage.

Notes:

1. While primary-reactor/primary-resistor starters do not require a transition or proof-of-transition contact closure to operate safely, the UCP695 panel does need these signals to verify that a proper start sequence occurred.

When adapting an existing primary-reactor/primary-resistor starter for UCP695 compatibility, keep in mind that the auxiliary contacts normally supplied on contactors are not compatible with the "transition complete" circuit. Use RLY-847 (provided) between the auxiliary contacts and Terminals 2TB1-10 and -11 to ensure compatibility of the contact material.

2. Relay coils for 1U2K1 through 1U2K5 are not shown since the contacts are controlled by micro module (1U3) logic.

Drwg. X39470503A

Figure 21
Typical Schematic
for UCP695-Compatible,
Autotransformer Starters

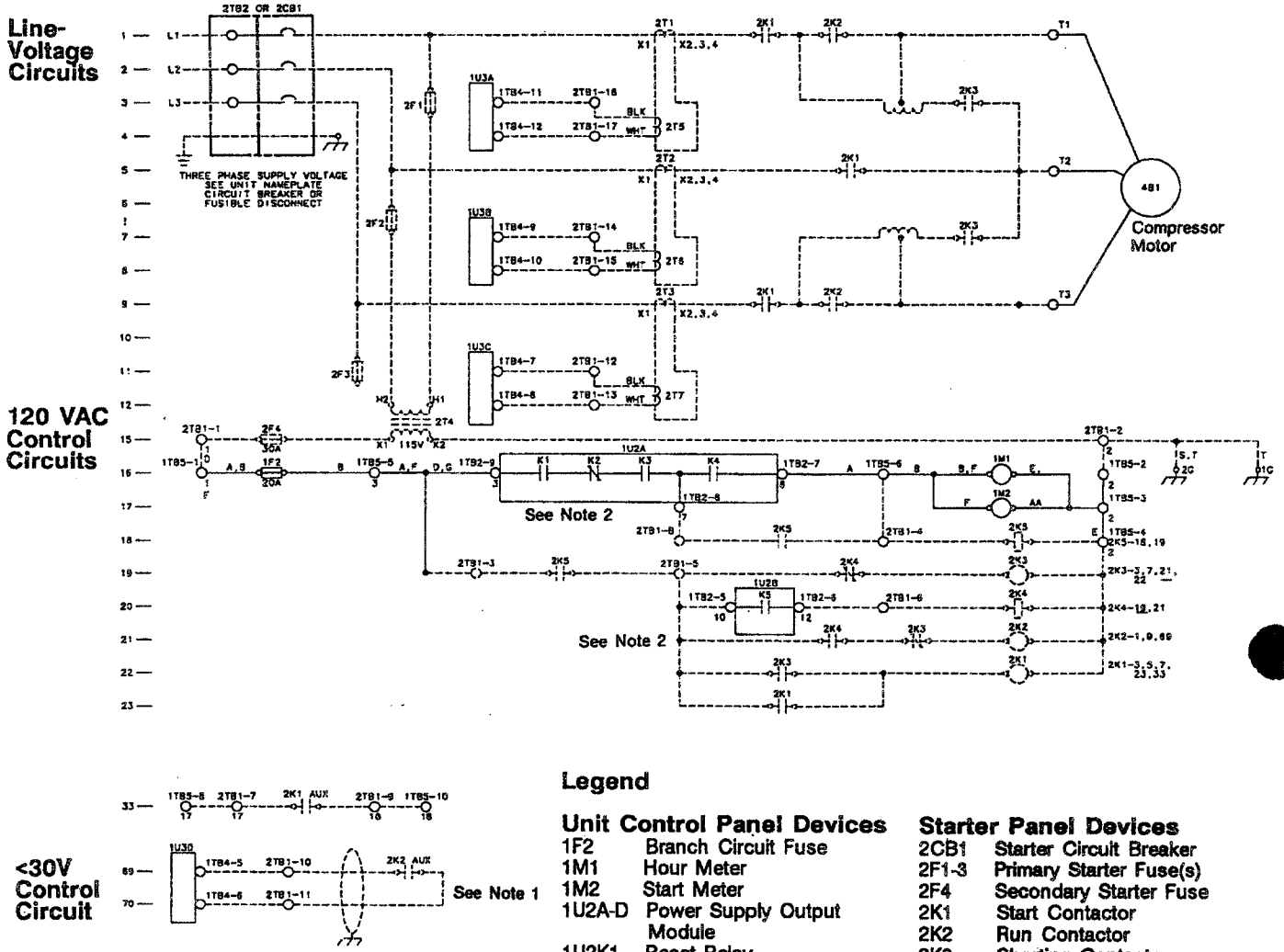

Legend

Unit Control Panel Devices		Starter Panel Devices	
1F2	Branch Circuit Fuse	2CB1	Starter Circuit Breaker
1M1	Hour Meter	2F1-3	Primary Starter Fuse(s)
1M2	Start Meter	2F4	Secondary Starter Fuse
1U2A-D	Power Supply Output Module	2K1	Start Contactor
1U2K1	Reset Relay	2K2	Run Contactor
1U2K2	Stop Relay	2K3	Shorting Contactor
1U2K3	Overload Relay	2K4	Transition Contactor
1U2K4	Compressor Start Relay	2K5	Pilot Relay
1U2K5	Compressor Transition Relay	2T1-3	Line CTs
1U3A-D	Micro Module	2T4	Control Power Transformer
		2T5-7	Auxiliary CTs
		2TB1	Control Terminal Block
		2TB2	Line Terminal Block

Notes:

1. While autotransformer starters do not require a transition or proof-of-transition contact closure to operate safely, the UCP695 panel does need these signals to verify that a proper start sequence occurred.

When adapting an existing autotransformer starter for UCP695 compatibility, keep in mind that the auxiliary contacts normally supplied on contactors are not compatible with the "transition complete" circuit. Use RLY-847 (provided) between the auxiliary contacts and Terminals 2TB1-10 and -11 to ensure compatibility of the contact material.

2. Relay coils for 1U2K1 through 1U2K5 are not shown since the contacts are controlled by micro module (1U3) logic.

Drwg. X39470503A

WARNING
Disconnect electrical power supply to prevent injury or death due to electrical shock.

Caution
Unless otherwise specified, use only copper conductors to prevent equipment damage.

Installation Checklist

To ensure that all of the steps required to retrofit a Model CVHE (or CVHB, CVHA, PCV) GenTraVac with a UCP695 control system are complete, review the following checklist before performing the "post-conversion" checkout procedures described in the next section of this manual.

Note: This checklist is not intended to replace the detailed instructions provided in Installation. Read that section carefully to become familiar with the "conversion" process before attempting to install the UCP695 panel.

WARNING: To prevent injury or death due to electrical shock, verify that all power supply disconnect switches are locked OFF before disconnecting any wires, or opening control (or starter) panel door.

Existing Control Panel Removal

- Identify and label all field-installed wiring entering control panel.
- Disconnect leads from unit oil heater.
- Connect field-supplied thermostat and auxiliary 115V power supply to oil heater.
- Disconnect all field-installed wiring entering control panel from terminal strips; remove conduit from panel enclosure.
- Remove sensors from start-stop, high oil temperature, and low refrigerant temperature switches.
- Identify and label all wiring between unit-mounted components and control panel; then disconnect wiring at terminal strips.
- Remove factory-installed conduit from panel and set it aside for reuse when new panel is installed.
- Disconnect panel pressure gauge lines at unit connections; plug (or "valve off") unit openings.
- Detach gauge lines from control panel and set them aside for reuse when new panel is installed.
- Remove control panel from chiller.
- Remove chiller nameplate from old panel and install it on new panel (near "CVRA" nameplate).
- Remove inlet vane actuator; retain connecting hardware and 3 115V leads for reuse when new actuator is installed.
- If a new purge was ordered, remove "existing" purge assembly.

Typical CVHE Conversions

UCP695 Panel Installation

Install mounting brackets and mount UCP695 panel on unit; use star washers on all panel-to-machine connections.

Install bulbwells for oil sump, evaporator refrigerant, and entering and leaving evaporator water temperature sensors.

Install 8 temperature sensors provided with UCP695 panel.

"CVRA" Package w/Purge Only. Install PRG-72 at or above purge connection on condenser, and complete wiring connections to UCP695 panel.

Units w/PRG-71 or -70 Only. Modify existing purge wiring so that its operation is governed by 1U1K9 contacts. If desired, remove purge gauge from old control panel and install it on purge assembly.

Install new vane actuator on chiller, but do not connect guide vanes!

Complete all low- and 115-voltage wiring between unit-mounted controls and UCP695 panel.

Caution: To prevent possible control malfunction due to electrical noise, never route low-voltage circuits with other conductors carrying 30V or more!

Install pressure gauge lines between unit connections and UCP695 panel.

Starter Conversion

Identify and remove all existing, nonessential starter components.

Fabricate and install cover plate over openings left in starter panel door by removal of breakers and, if applicable, fuses.

Relabel both ends of 4 wires still connected to TB1 with new wire numbers; then disconnect each wire from TB1.

Remove TB1 from starter and install new terminal strip (2TB1) in its place.

Reconnect 4 wires just removed from TB1 to appropriate 2TB1 terminals.

Relabel both ends of all remaining wires in starter with new wire numbers.

Relabel each existing starter panel component with its new electrical designation.

Install new line and auxiliary CTs; label each with its electrical designation.

Install "proof-of-transition" relay near 2TB1 and label it.

Install fuse block and 30-amp, secondary starter fuse (2F4) in starter.

Complete the necessary 120- and <30-volt wire additions within the starter.

Caution: To prevent possible control malfunction due to electrical noise, maintain at least 6" between <30 V circuits and those carrying 30V or more!

Complete the electrical connections between the starter and UCP695 panel.

Contact a qualified service organization to perform (or supervise) "post-UCP695-conversion" checkout.

Non-CVHE Conversions

UCP695 Panel Installation

Follow instructions under "Typical CVHE Conversions: UCP695 Panel Installation".

Units w/115V Oil Pump Contactor Coils Only. Connect coil between Terminals 1TB5-11 and 1TB5-4; remove 1K8 and 1C1 from UCP695 panel.

Units w/Non-115V Oil Pump Contactor Coils Only. Convert coil to 115 VAC, or connect auxiliary 2K1 contacts between Terminals 1TB5-9 and 1TB5-11.

Units w/Robertshaw Modules and RTD Sensors. Connect Terminals 1TB4-15 thru -18 directly to RTD terminals on motor.

Units w/Motor T'stats Only. Wire field-supplied isolation relay and resistors to thermostat to simulate RTD sensors (Figure 9).

Shorten existing actuator arm; install new vane actuator with mounting plate and adapter brackets.

Modify existing purge control as necessary, but retain all existing purge safety controls!

Starter Conversion

Follow instructions under "Typical CVHE Conversions: Starter Conversion".

Install field-supplied 115V/3KVA control power transformer in starter, if necessary.

Install "proof-of-transition" relay.

Non-115V Starter Control Circuits Only:

Modify start relay interface (Figure 17).

Install field-supplied isolation relay for starter transition interface (Figure 18).

All Non-CVHE Conversion Applications:

Contact a qualified service organization to perform (or supervise) "post-UCP695-conversion" checkout.

Post-Conversion Checkout

Following are recommended checkout procedures for the converted starter panel and newly-installed UCP695 control panel. Since specific, step-by-step instructions for portions of this procedure are only described in CVHE service guide CTV-SG-2, contact a qualified service organization (i.e., one with access to this service guide) for assistance.

Caution: To prevent machine damage, contact a qualified service organization to perform the checkout procedures described in this section.

Successful completion of these operational checks assures that the UCP695 panel is properly installed, that all required starter and chiller modifications are complete, and that the chiller is functioning normally.

Starter Panel Checkout

Perform the starter dry-run procedure described under "Start-Up Day 1" in Section 4.1 of CVHE service guide CTV-SG-2. Notice that it does not require the removal of the compressor motor leads.

Note: While the dry-run procedure described in Section 4.1 is specifically intended for wye-delta starters, it can be modified to check out across-the-line, autotransformer and primary reactor starters.

UCP695 Panel/Chiller Checkout

1. Remove the field-supplied thermostat and auxiliary 115-volt power source that was connected to the oil heater when the old control panel was removed.

2. Once all electrical and piping connections are complete, ensure that the chiller switch (on the UCP695 panel) is set at "Standby/Reset" and close the main power supply disconnect switch(es) to "power up" the control panel.

3. Calibrate the UCP695 panel's operating controls; see Section 7.23 of CTV-SG-2 for recommended control settings.

4. Check and adjust the travel of the new electric vane actuator before connecting it to the guide vanes; to do this:

a. Adjust the UCP695 panel's vane control knob to "Unload" to drive the actuator fully closed.

Note: Notice that the new actuator uses a double-cam arrangement to set travel; the actuator's "vanes closed" switch is activated by the fixed cam.

b. Thread the drive arm in and out as necessary to align the drive arm with the vane linkage. Be sure to allow some "slack" so that the vanes do not bind when in the full-closed position.

c. Manually open the vanes to the full-open position.

d. Adjust the UCP695 panel's vane control knob to "Load" to drive the actuator fully open. Once the "vanes open" end switch stops actuator movement, check the alignment of the drive arm with the vane linkage.

If the drive arm and vane linkage do not align, loosen the 2 small screws on the end of the cam mechanism; then turn the cam to obtain the necessary amount of travel.

e. Connect the vane linkage to the actuator motor.

5. Check purge operation.

6. Ensure that the vane control knob is set at "Auto"; then start the unit (i.e., see Section 4.1 of CTV-SG-2).

a. Allow the unit to load to a current limit setting of 40% while air is purged from the system.

b. Once purging is complete, check overload calibration by slowly reducing the current limit control setting until an "unload" pulse is indicated on the panel; then compare the displayed current limit setting with the measured RLA.

Note: If the displayed current limit setting is not within 5% of the measured RLA, refer to Section 6.19 of CTV-SG-2 for troubleshooting instructions.

c. Set the evaporator refrigerant trip point (temperature) to the desired setting; then decrease the chilled water setpoint until the evaporator refrigerant temperature is within 6 F of the trip point. If the UCP695 panel's "freeze protection" function is operative, its display should indicate the "A/T" evaporator limit operating mode (i.e., if no other limit modes are presently active).

Note: Sensor calibration and control at 32 F (in an ice bath) can be confirmed by performing the sensor checkout procedure described in Section 6.21 of CTV-SG-2.

7. Operate the chiller through its normal operating range to determine if the control adjustments are adequate.

* * * * *

Once the starter and UCP695 control panel checkout procedures are completed successfully, the conversion process is complete.

For further information on this product or other Trane products, refer to the "Trane Service Literature Catalog", ordering number IDX-IOM-1. This catalog contains listings and prices for all service literature sold by Trane. The catalog may be ordered by sending a \$20.00 check to: The Trane Company, Service Literature Sales, 3600 Pammel Creek Road, La Crosse, WI 54601.