



Operation Maintenance

CVHE-M-6

Library	Service Literature
Product Section	Refrigeration
Product	Centrifugal Liq. Chiller, Water-Cooled
Model	60 HZ CVHE, CVHF(Cooling-Only & Heat Recovery)
Literature Type	Operation/Maintenance
Sequence	6
Date	February 1993
File No.	SV-RF-CTV-CVHE-M-6-2/93
Supersedes	

Water-Cooled, Hermetic CentraVac®

Models CVHE and CVHF

Cooling-Only and Heat-Recovery,
Direct-Drive CentraVacs with UCP695
Control Panels

CVHE 230 thru CVHE-890, 1120, 1250
"1A through 1U" Design Sequences

CVHF 650, 770, 910
1060, 1280

"C0" Design Sequence

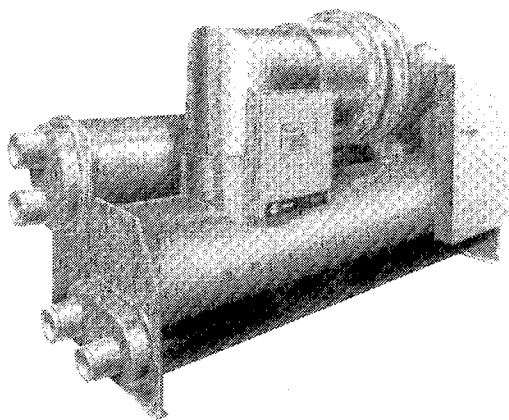
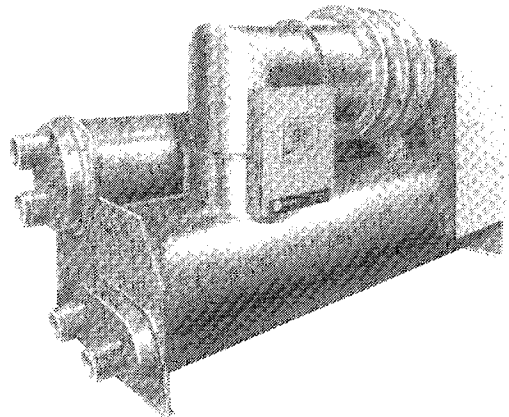

X39470713-01

Table of Contents

<ul style="list-style-type: none"> 3 Product Coding Definition 3 Introduction 3 Typical Prod. Description Block 3 CVHE Product Coding Explanation 8 General Information 8 Literature Change History 8 About this manual 8 Commonly Used Acronyms 8 Warnings and Cautions 9 Unit Nameplate 10 Mechanical Operation - CVHE 10 Overview 10 Cooling Only Cycle 13 Compressor Lubrication System - CVHE 13 Motor Cooling System 16 Mechanical Operation - CVHF 16 Overview 16 Cooling-Only Cycle 16 Free Cooling, Heat Recovery and Auxiliary Condenser Cycles 19 Compressor Lubrication System - CVHF 19 Motor Cooling System 22 Free Cooling Cycle (Optional) - CVHE/CVHF 23 Heat Recovery Cycle (Optional) 23 Auxiliary Condensers 24 Chiller Control System 24 Unit Control Panel 24 Relay Output Module (1U1) 24 Power Supply Output Module (1U2) 25 Micro Module (1U3) 25 Advanced Motor Protection 28 Operator Interface 28 --Chiller Switch 28 --Oil Pump Switch 29 --Purge Switch 29 --Chilled Water Setpoint 29 --Current Limit Setpoint 29 --Vane Control Switch 30 --Free Cooling Switch (Optional) 30 --Unit Status Lights 30 --UCP Display 32 Service Interface 34 --Clear Restart inhibit Push-Button 34 --Control Response Setpoint 34 --Start Differential Setpoint 34 --Condenser Limit Setpoint (Optional) 35 --Evaporator Refrigerant Trip 35 --UCP "Summary Sheet" 	<ul style="list-style-type: none"> 36 Electrical Sequence of Operation 36 Overview 36 Fuse 1F2 Branch Circuit 36 Chilled and Condenser Water Flow Interlock Circuits 36 Micro Module and Wye-Delta-Starter Control circuits 44 Fuse 1F3 Branch Circuit Oil Pump Circuit 44 Vane Actuator Circuit 45 Purge System 46 Control Options 46 Free Cooling 46 Hot Gas Bypass 46 --HGBP Relay 1K15 46 --HGBP Transfer Switch 4S4 46 --HGBP Valve Switch 4B5 47 --Discharge Temperature Switch (4S5) 47 Relay Package 48 Bearing Temperature Sensors (4RT8, 4RT9) 48 Sensor Options 57 Serial Communication Interface (SCI) 57 Chilled Water Reset (CWR) 57 --Load-Based CWR 59 --Ambient-Based CWR 60 Remote Generic BAS/CWR Interface 62 Unit Start-Up Procedures 62 Daily Unit Start-Up 66 Seasonal Startup 67 Unit Shutdown Procedures 67 Daily Unit Shutdown 67 Seasonal Unit Shutdown 68 Periodic Maintenance 68 Overview 68 Daily Maintenance and Checks 68 Weekly Maintenance 70 Every 3 Months 70 Every 6 Months 70 Off-Season Maintenance 70 Annual Maintenance 	<ul style="list-style-type: none"> 70 Compressor Oil Change on CVHE/CVHF units 70 --Oil Change Procedure 70 --Replacing Oil Filter 70 --Replacement Procedure 72 Other Maintenance Requirements 72 Lubrication 72 Refrigerant Charge 72 Recovery/Recycle Connections 73 Leak Testing 73 Refrigerant Charging 74 Periodic Maintenance 74 Cleaning the Condenser 75 Cleaning the Evaporator 75 Control Settings and Adjustments 76 Purge System 77 Trouble Analysis 77 UCP695 Control System 77 UCP Summary Sheet
--	---	---

Notice

The Trane Company urges that all HVAC servicers working on Trane equipment, or any manufacturer's products, make every effort to eliminate, if possible, or vigorously reduce the emission of CFC, HCFC, and HFC refrigerants to the atmosphere resulting from installation, operation, routine maintenance, or major service on this equipment. Always act in a responsible manner to conserve refrigerants for continued use even when acceptable alternatives are available.

Conservation and emission-reduction can be accomplished by following recommended Trane service and safety procedures published in Trane general service manuals "CTV-SB-81", "CTV-SB-82" and CFC-Guide 2. Copies of these manuals may be obtained by contacting your local Trane commercial product representative.

Product Coding Definition

Introduction

The CVHE 130-1250 and the CVHF 650-1280 is defined using the product definition and selection (PDS) system. This system describes the product offerings in terms of a product coding block which is made up of feature categories and feature codes.

Typical Product Description Block

MODL CVHE	DSEQ S
HRTZ 60	TYPE SNGL
EVTM IECU	EVTH 28
EVWC STD	EVWP 2
EVCO FLNG	EVWA RERE
CDSZ 080L	CDBS 800
CDWT NMAR	CDPR 150
CDTY STD	ORSZ 710
AGLT NONE	CNIF MICR

The operating components and options for any Model CVHE/ CVHF CenTraVac unit can be identified by referring to the alpha-numeric product identification coding block located on the nameplate for the unit. The coding block precisely identifies all characteristics of a unit. Be sure to refer to the service model number when

ordering replacement parts or requesting service. An example of a typical product code is given on this page.

Note: Unit-mounted starters are identified by a separate number found on the starter.

TYPE

Unit Type

SNGL = Single Condenser
(Cooling Only)
HTRC = Heat Recovery
AUX = Auxiliary Condenser

TYPO

Unit Type

STD = Standard Shells
EXTD = Extended Surface Shells

CVHE/CVHF Product Coding Explanation

MODL

Unit Model

CVHE = CenTraVac Direct Drive
Hermetic
Development Sequence "E"
CVHF = CenTraVac Direct Drive
Hermetic
Development Sequence "F"

DSEQ

Design Sequence

S = HCFC123 Gaskets & O Rings

NTON

Unit Nominal Capacity (Tons)

230 = 230 Tons
250 = 250 Tons
280 = 280 Tons
300 = 300 Tons
320 = 320 Tons
360 = 360 Tons
400 = 400 Tons
450 = 450 Tons
500 = 500 Tons
560 = 560 Tons
630 = 630 Tons

NTON 800	VOLT 4160
CPKW 650	CPIM 275
EVSZ 080L	EVBS 890
EVWT NMAR	EVPR 150
CDTM IECU	CDTH 28
CDWC STD	CDWP 2
CDCO FLNG	CDWA RERE
PURG HERM	HGBP W/O
SRTY RPIR	

650 = 650 Tons
710 = 710 Tons
770 = 770 Tons
800 = 800 Tons
890 = 890 Tons
910 = 910 Tons
1060 = 1060 Tons
1120 = 1120 Tons
1250 = 1250 Tons
1280 = 1250 Tons

VOLT

Unit Voltage

200 = 200/60/3
208 = 208/60/3
230 = 230/60/3
380 = 380/60/50/3
440 = 440/60/3
460 = 460/60/3
480 = 480/60/3
575 = 575/60/3
600 = 600/60/3
2300 = 2300/60/3
2400 = 2400/60/3
3300 = 3300/60/50/3
4000 = 4000/60/3
4160 = 4160/60/3
4800 = 4800/60/3
6600 = 6600/60/3

HRTZ

Unit Hertz

60 = 60 Hertz

CPKW

Compressor Motor

Kilowatts

96 = 96 KW
106 = 108 KW
131 = 131 KW
142 = 142 KW
154 = 154 KW
171 = 171 KW
187 = 187 KW
204 = 204 KW
231 = 231 KW
257 = 257 KW
287 = 287 KW
323 = 323 KW
361 = 361 KW
403 = 403 KW
453 = 453 KW
512 = 512 KW
588 = 588 KW
653 = 653 KW
361 = 361 KW
745 = 745 KW
856 = 856 KW
957 = 957 KW
1062 = 1062 KW
1228 = 1228 KW

CPIM

Compressor Impeller-Diameter

	3-STAGE			2-STAGE	
220	22.0	22.0	22.0		
222	22.5	22.0	22.0		
223	22.5	22.5	22.0		
225	22.5	22.5	22.5		
227	23.0	22.5	22.5		
228	23.0	23.0	22.5		
230	23.0	23.0	23.0		
232	23.5	23.0	23.0		
233	23.5	23.5	23.0		
235	23.5	23.5	23.5		
237	24.0	23.5	23.5		
238	24.0	24.0	23.5		
240	24.0	24.0	24.0		
242	24.5	24.0	24.0		
243	24.5	24.5	24.0		
245	24.5	24.5	24.5		
247	25.0	24.5	24.5		
248	25.0	25.0	24.5		
250	25.0	25.0	25.0		
252	25.5	25.0	25.0		
253	25.5	25.5	25.0		
255	25.5	25.5	25.5		
257	26.0	25.5	25.5		
258	26.0	26.0	25.5		
260	26.0	26.0	26.0		
262	26.5	26.0	26.0		
263	26.5	26.5	26.0		
265	26.5	26.5	26.5		
267	27.0	26.5	26.5		
268	27.0	27.0	26.5		
270	27.0	27.0	27.0	27.00	27.00
271				27.25	27.00
272	27.5	27.0	27.0		
273	27.5	27.5	27.0	27.25	27.25
274				27.50	27.50
275	27.5	27.5	27.5	27.50	27.50
276				27.75	27.75
277	28.0	27.5	27.5		
278	28.0	28.0	27.5	27.75	27.75
279				28.00	27.75
280	28.0	28.0	28.0	28.00	28.00
281				28.50	28.00
282	28.5	28.0	28.0		
283	28.5	28.5			
284				28.50	28.50
285	28.5	28.5	28.5	28.55	28.50
286				28.75	28.50
287	29.0	29.0	28.5	28.75	28.75
288	29.0	29.0	28.5	28.75	28.75
289				29.00	28.75
290	29.0	29.0	29.0	29.00	29.00
291				29.25	29.00
292	29.5	29.0	29.0		

294				29.50	29.50
295	29.5	29.5	29.5	29.50	29.50
296	31.0	30.5	30.5		
297	30.0	29.5	29.5		
298	30.0	30.0	29.5	29.75	29.75
299				30.00	29.75
300	30.0	30.0	30.0	30.00	30.00
301				30.25	30.00
302	30.5	30.0	30.0		
303	30.5	30.5	30.0	30.25	30.25
304				30.50	30.25
305	30.5	30.5	30.5	30.50	30.50
307	31.0	30.5	30.5		
308	31.0	31.0	30.5	30.75	30.75
309				31.00	30.75
310	31.0	31.0	31.0	31.00	31.00
311				31.25	31.00
312	31.5	31.0	31.0		
313	31.5	31.5	31.0	31.25	31.25
314				31.50	31.25
315	31.5	31.5	31.5	31.50	31.50
316				31.75	31.50
317	31.0	31.5	31.5		
318	32.0	32.0	31.5		
319				32.00	31.75
320	32.0	32.0	32.0	32.00	32.00
321				32.25	32.00
322	32.5	32.0	32.0		
323	32.5	32.5	32.0	32.25	32.25
324				32.50	32.50
325	32.5	32.5	32.5	32.50	32.50
326				32.75	32.50
327	33.0	32.5	32.5		
328	33.0	33.0	32.5	32.75	32.75
329				33.00	32.50
330	33.0	33.0	33.0	33.00	33.00

EVTM

Evaporator Tube Material

IECU = Internally Enhanced CU -1"
 SBCU = Smooth Bore CU
 SB91 = Smooth Bore CU/NI 90/10
 TECU = Internally Enhanced CU - 3/4"

EVTH

Evaporator Tube Wall Thickness

28 = .028 Wall Thickness
 35 = .035 Wall Thickness

EVSZ

Evaporator Shell Size

032S = 300 Ton Short Shell
 032L = 300 Ton Long Shell
 050S = 500 Ton Short Shell
 050L = 500 Ton Long Shell
 80S = 800 Ton Long Shell
 080L = 800 Ton Long Shell
 125L = 1250 Ton Long Shell
 140E = 1400 Extended Length Shell
 142M = 1400 Ton Medium Shell

142M = 1400 Ton Medium Shell
 142L = 1400 Ton Long Shell
 210M = 2100 Ton Medium Shell
 210L = 2100 Ton Long Shell

EVBS

Evaporator Tube Bundle Size

200 = 200 Nominal Tons
 220 = 220 Nominal Tons
 230 = 230 Nominal Tons
 250 = 250 Nominal Tons
 280 = 280 Nominal Tons
 320 = 320 Nominal Tons
 350 = 350 Nominal Tons
 360 = 360 Nominal Tons
 400 = 400 Nominal Tons
 450 = 450 Nominal Tons
 500 = 500 Nominal Tons
 550 = 550 Nominal Tons
 560 = 560 Nominal Tons
 630 = 630 Nominal Tons
 710 = 710 Nominal Tons
 800 = 800 Nominal Tons
 900 = 900 Nominal Tons
 985 = 985 Nominal Tons
 1000 = 1000 Nominal Tons
 1080 = 1080 Nominal Tons
 1120 = 1120 Nominal Tons
 1225 = 1225 Nominal Tons
 1250 = 1250 Nominal Tons
 1400 = 1400 Nominal Tons
 1425 = 1425 Nominal Tons
 1450 = 1450 Nominal Tons
 1610 = 1610 Nominal Tons
 1765 = 1765 Nominal Tons
 1900 = 1900 Nominal Tons
 2100 = 2100 Nominal Tons

EVWC

Evaporator Waterbox Construction

STD = Standard Welded
 ASME = ASME Welded - Water-Side

EVWP

Evaporator Water Passes

1 = One Pass
 2 = Two Pass
 3 = Three Pass

EVWT

Evaporator Waterbox Type

MAR = Marine
 NMAR = Non-Marine

EVPR

Evaporator Waterside Pressure

150 = 150 PSIG
 300 = 300 PSIG

EVCO

Evaporator Waterbox Connection

VICT = Victaulic
FLNG = Flanged

EVWA

Evaporator Waterbox Arrangement

FRNT = In Front/Out Front
REAR = In Rear/Out Rear
LFRR = In LH Front/Out RH Rear
RRLF = In RH Rear/Out LH Front
LRRF = In Rear/Out RH Front
RFLR = In Front/Out LH Rear
LFLR = In LH Front/Out LH Rear
LRLF = In LH Rear/Out LH Front
RFRF = In RH Front/Out RH Rear
RRRF = In RH Rear/Out RH Front
END = In One End/Out the Other
RERE = In RH End/Out RH End
LELE = In LH End/Out LH End

CDTM

Condenser Tube Material

IECU = Internally Enhanced CU-1"
SBCU = Smooth Bore CU
SB91 = Smooth Bore CU/NI 90/10
SB73 = Smooth Bore CU/NI 70/30
SBT1 = Smooth Bore Titanium
TECU = Internally Enhanced CU-3/4"

CDTH

Condenser Tube Thickness

28 = .028 Wall Thickness
35 = .035 Wall Thickness
42 = .042 Wall Thickness
49 = .049 Wall Thickness

CDSZ

Condenser Shell Size

032S = 320 Ton Short Shell
032L = 320 Ton Long Shell
050S = 500 Ton Short Shell
050L = 500 Ton Long Shell
080S = 800 Ton Short Shell
080L = 800 Ton Long Shell
125L = 1250 Ton Long Shell
140L = 1400 Ton Long Shell
142S = 1400 Ton Short Shell
142L = 1400 Ton Long Shell
210S = 2100 Ton Short Shell
210L = 2100 Ton Long Shell

CDBS

Condenser Tube Bundle Size

200 = 200 Nominal Tons
220 = 220 Nominal Tons
230 = 230 Nominal Tons
250 = 250 Nominal Tons
280 = 280 Nominal Tons
320 = 320 Nominal Tons
350 = 350 Nominal Tons
360 = 360 Nominal Tons

400 = 400 Nominal Tons
450 = 450 Nominal Tons
500 = 500 Nominal Tons
550 = 550 Nominal Tons
560 = 560 Nominal Tons
630 = 630 Nominal Tons
710 = 710 Nominal Tons
800 = 800 Nominal Tons
890 = 890 Nominal Tons
900 = 900 Nominal Tons
985 = 985 Nominal Tons
1000 = 1000 Nominal Tons
1080 = 1080 Nominal Tons
1120 = 1120 Nominal Tons
1225 = 1225 Nominal Tons
1250 = 1250 Nominal Tons
1400 = 1400 Nominal Tons
1425 = 1425 Nominal Tons
1610 = 1610 Nominal Tons
1765 = 1765 Nominal Tons
1900 = 1900 Nominal Tons
2100 = 2100 Nominal Tons

CDWC

Condenser Water Box Construction

STD = Standard Welded
ASME = ASME Welded - Water-Side

CDWP

Condenser Water Passes

2 = 2 Pass
3 = 3 Pass

CDWT

Condenser Waterbox Type

MAR = Marine
NMAR = Non-Marine

CDPR

Condenser Water Side Pressure

150 = 150 PSIG
300 = 300 PSIG

CDCO

Condenser Waterbox Connection

VICT = Victaulic
FLNG = Flanged

CDWA

Condenser Waterbox Arrangement

LFLF = In LH Front/Out LF Front
LRLR = In LH Rear/Out LH Rear
RFRF = In RH Front/Out RH Front
RRRR = In RH Rear/Out RH Rear
LFLR = In LH Front/Out LH Rear
LRLF = In LH Rear/Out LH Front
RFRF = In RH Front/Out RH Rear
RRLF = In RH Rear/Out RH Front
RERE = In RH End/Out RH End
LELE = In LH End/Out LH End

CDTY

Condenser Construction - Refrigerant Side

STD = Standard Welded
ASME = ASME Welded

TSTY

Tube Sheet Construction

STD = Standard Welded
ASME = ASME Welded

CHTM

Heat Rec. Condenser Tube Material

IECU = Internal Enhance CU -1"
SBCU = Smooth Bore CU
SB91 = Smooth Bore CU/NI 90/10
SB73 = Smooth Bore CU/NI 70/30
SBT1 = Smooth Bore Titanium
TECU = Internally Enhanced CU-3/4"

CHTH

Heat Rec. Condenser Tube Wall Thickness

28 = .028 Wall Thickness
35 = .035 Wall Thickness
42 = .042 Wall Thickness
49 = .049 Wall Thickness

CHSZ

Heat Rec. Condenser Shell Size

032S = 320 Ton Short Shell
032L = 320 Ton Long Shell
050S = 500 Ton Short Shell
050L = 500 Ton Long Shell
080S = 800 Ton Short Shell
080L = 800 Ton Long Shell
125L = 1250 Ton Long Shell
140L = 1400 Ton Long Shell

CHBS

Heat Rec. Condenser Tube Bundle Size

200 = 200 Nominal Tons
230 = 230 Nominal Tons
250 = 250 Nominal Tons
280 = 280 Nominal Tons
320 = 320 Nominal Tons
360 = 360 Nominal Tons
400 = 400 Nominal Tons
450 = 450 Nominal Tons
500 = 500 Nominal Tons
560 = 560 Nominal Tons
630 = 630 Nominal Tons
710 = 710 Nominal Tons
800 = 800 Nominal Tons
900 = 900 Nominal Tons
1000 = 1000 Nominal Tons
1120 = 1120 Nominal Tons
1250 = 1250 Nominal Tons

1400 = 1400 Nominal Tons

CHWC

Heat Rec. Condenser Waterbox Construction

STD = Standard Welded

ASME = ASME Welded - Water Side

CHWP

Heat Rec. Condenser Water Passes

2 = 2 Pass

3 = 3 Pass

CHWT

Heat Rec. Condenser Waterbox Type

MAR = Marine

NMAR = Non-Marine

CHPR

Heat Rec. Condenser Waterbox Side Pressure

150 = 150 PSIG

300 = 300 PSIG

CHCO

Heat Rec. Condenser Waterbox Connections

VICT = Victaulic

FLNG = Flanged

CHWA

Heat Rec. Condenser Waterbox Arrangement

LFLF = In LH Front/Out LF Front

LRLR = In LH Rear/Out LH Rear

RFRF = In RH Front/Out RH Front

RRRR = In RH Rear/Out RH Front

LFLR = In LH Front/Out LH Rear

LRLF = In LH Rear/Out LH Front

RFRR = In RH Front/Out RH Rear

RRRF = In RH Rear/Out RH Front

RERE = In RH End/Out RH End

LELE = In LH End/Out LH End

CABS

Auxiliary Condenser Nominal Tonnage

80 = 80 Nominal Tons

130 = 130 Nominal Tons

CAWC

Auxiliary Condenser Waterbox Construction

STD = Standard Welded

ASME = ASME Welded - Water Side

CATM

Auxiliary Condenser Tube Material

IECU = Internal Enhance CU -1"

SBCU = Smooth Bore CU

SB91 = Smooth Bore CU/NI 90/10

SB73 = Smooth Bore CU/NI 70/30

SBT1 = Smooth Bore Titanium

TECU = Internally Enhanced CU -3/4"

CATH

Auxiliary Condenser Tube Wall Thickness

28 = .028 Wall Thickness

35 = .035 Wall Thickness

42 = .042 Wall Thickness

CACO

Auxiliary Condenser Waterbox Connection

VICT = Victaulic

FLNG = Flanged

CAPR

Auxiliary Condenser Water Side Pressure

150 = 150 PSIG

300 = 300 PSIG

CAWT

Auxiliary Condenser Waterbox Type

MAR = Marine

NMAR = Non-Marine

CAWA

Auxiliary Condenser Waterbox Arrangement

LFLF = In LH Front/Out LF Front

LRLR = In LH Rear/Out LH Rear

RFRF = In RH Front/Out RH Front

RRRR = In RH Rear/Out RH Front

LFLR = In LH Front/Out LH Rear

LRLF = In LH Rear/Out LH Front

RFRR = In RH Front/Out RH Rear

RRRF = In RH Rear/Out RH Front

RERE = In RH End/Out RH End

LELE = In LH End/Out LH End

ECTY

Economiser Orifice Type

WEOR = Welded

REOR = Bolted Removable

ORSZ

Orifice Size

130 = Orifice Size

140 = Orifice Size

160 = Orifice Size

180 = Orifice Size

200 = Orifice Size

230 = Orifice Size

250 = Orifice Size

280 = Orifice Size

320 = Orifice Size

360 = Orifice Size

375 = Orifice Size

400 = Orifice Size

415 = Orifice Size

450 = Orifice Size

460 = Orifice Size

500 = Orifice Size

510 = Orifice Size

560 = Orifice Size

585 = Orifice Size

630 = Orifice Size

650 = Orifice Size

710 = Orifice Size

790 = Orifice Size

800 = Orifice Size

880 = Orifice Size

900 = Orifice Size

990 = Orifice Size

1000 = Orifice Size

1100 = Orifice Size

1120 = Orifice Size

1250 = Orifice Size

1265 = Orifice Size

1400 = Orifice Size

1540 = Orifice Size

1600 = Orifice Size

1660 = Orifice Size

1800 = Orifice Size

1810 = Orifice Size

1970 = Orifice Size

2150 = Orifice Size

PURGE

Purge Unit

PURE = Purifier Unit

SPKG

Shipping Package

DOM = Domestic

EXP = Export

FULL = Export

OPTI

Unit Options

CLCT = Condenser Limit Control
BRTS = Bearing Temperature Sensor
EVWS = Evaporator Water Sensor
TRMP = Tracer Monitoring Package
ALRP = Relay Package
CDWS = Condenser Water Sensor
CRTS = Condenser Refrigerant Temp Sensor
ELLG = Evap Liquid Level Gage
NZEP = Near Zero Emission Purge
ISLS = Spring Isolator
INSL = Insulation Package
CPDW = Compressor Doweling
TMEW = Thermometer 10 Inch Ext Well
TMSW = Thermometer 10 Inch Std Well
T5RT = T5 Timer
FRCL = Free Cooling

HGBP

Hot Gas By-Pass

With = With
W/O = Without

AGLT

Agency Listing

NONE = No Agency Listings
UL = Underwriter Laboratory
CSA = Canadian Standard Assoc.

CNIF

Control Interface

MICR = Standard Micro Processor
CWR = Chilled Water Reset
SCI = Serial Communications Interface
GBAS = Generic BAS Interface for Chilled Water Reset

SRTY

Starter Type

USTR = Unit Mounted Star-Delta
RSTR = Remote Mounted Star-Delta
RXL = Remote Mounted X-Line
RATR = Remote Mounted Auto Transformer
RPIR = Remote Mounted Primary Reactor
CSTR = Customer Supplied Star-Delta
CXL = Customer Supplied X-Line - Full V
CATR = Customer Supplied Autotransformer
CPIR = Customer Supplied Primary Reactor

SRRL

Starter (Nameplate) RLA

PNCO

Starter Panel Connection

TERM = Terminal Block
DISC = Disconnect Switch (Noan-Fused)
CB = Circuit Breaker
CBIC = Circuit Breaker - High Interrupting Capacity
CBCL = Circuit Breaker - Current Limiting
ISSW = Isolation Switch
ISLB = Load Break Switch

25 = 25 KVAR
30 = 30 KVAR
35 = 35 KVAR
40 = 40 KVAR
45 = 45 KVAR
50 = 50 KVAR
60 = 60 KVAR
70 = 70 KVAR
75 = 75 KVAR
80 = 80 KVAR
90 = 90 KVAR
100 = 100 KVAR
120 = 120 KVAR
125 = 125 KVAR
150 = 150 KVAR
200 = 200 KVAR

SRPO

Electrical Protection

SPLA = Surge Protection Plus Lighting Arrestors
UVR = Undervolt Relay with Reset
AUVR = Adjustable Undervoltage Relay Reset Overvoltage Relay
OVR = Overvoltage Relay
GRDF = Ground Fault

SRPO

Starter Options

CLCA = California Code
CSA = Canadian Standards Assoc.
CTRV = Control Meter (Volt)
CTRA = Control Meter (AMP)
IQD = I.Q. Data
IQDP = I.Q. Data Plus
NEMA = NEMA 12
SRIT = Starter Interlocks
PLIT = Pilot Lights
TDRC = Transducer Current
TDRV = Transducer Volt
TDRW = Transducer Watt
UL = Underwriters Laborator
WTTM = Wattmeter
WHM = Watt Hour Meter
WHMD = Watt Hour Meter with Demand Register
WHMP = Watt Hour Meter with Pulse Initiator
WHMB = Watt Hour Meter with both Demand Register & Pulse Initiator

SRFC

Starter Power-Factor Correction Capacitors

10 = 10 KVAR
15 = 15 KVAR
20 = 20 KVAR

ACCY

Unit Accessory

ISLS = Isolator Spring
FS1 = (1) Flow Switch 150 PSI NEMA 1
2FS1 = (2) Flow Switches 150 PSI NEMA 1
3FS1 = (3) Flow Switches 150 PSI NEMA 1
FS2 = (1) Flow Switch 300 PSI NEMA 1
2FS2 = (2) Flow Switches 300 PSI NEMA 1
3FS2 = (3) Flow Switches 300 PSI NEMA 1
FS3 = (1) Flow Switch 150 PSI Vaporproof
2FS3 = (2) Flow Switches 150 PSI Vaporproof
3FS3 = (3) Flow Switches 150 PSI Vaporproof
FS4 = (1) Flow Switch 300 PSI Vaporproof
2FS4 = (2) Flow Switches 300 PSI Vaporproof
3FS4 = (3) Flow Switches 300 PSI Vaporproof
TME = (1) Thermometer 10 In Extended Well
2TME = (2) Thermometers 10 In Extended Well
3TME = (3) Thermometers 10 In
TMS = (1) Thermometer 10 In Standard Well
2TMS = (2) Thermometers 10 In Standard Well
3TMS = (3) Thermometers 10 In Standard Well
T5R = (1) T5R Timer
2T5R = (2) T5R Timers
3T5R = (3) T5R Timers
OR01 - OR28 = Extra Set of Orifice Plates (OR01 thru OR28)
OR30 - OR47 = Extra Set of Orifice Plates (OR30 thru OR47)

General Information

Literature Change History CVHE-M-6 (February 1993)

Original issue of manual; describes proper operation and maintenance of 60 Hz. CVHE units of "1A " through "1U " design sequences with UCP695 micro-computer-based control systems and CVHF 650 and 1280 "C0 " design sequences with UCP695 micro-computer-based control systems.

About this Manual

This booklet describes the operation and maintenance of 60 Hz. Model CVHE and CVHF CenTraVac chillers equipped with micro-computer-based control systems, whether standard (cooling) or heating-recovery. By carefully reviewing this information and following the instructions given, the owner/operator can successfully operate and maintain a CVHE or CVHF unit.

Diagnostic information is provided at the end of this manual to allow the operator to identify a number of system malfunctions, should any develop. (If mechanical problems do occur, however, contact a qualified service organization to ensure proper diagnosis and repair of the unit.)

Commonly Used Acronyms

For convenience, a number of acronyms are used throughout this manual. These acronyms are listed alphabetically below, along with the "translation" of each:

AMB = Outdoor Ambient Temperature

ASME = American Society of Mechanical Engineers

BAS = Building Automation System

CWR = Chilled Water Reset

DTFL = Design Delta-T at Full Load (i.e., the difference between entering and leaving chilled water temperatures)

ENT = Entering Chilled Water Temperature

FC = Free Cooling

HGBP = Hot Gas Bypass

HVAC = Heating, Ventilating, and Air Conditioning

IE = Internally-Enhanced Tubes

LVG = Leaving Chilled Water Temperature

PCWS = Front Panel Chilled Water Setpoint

PSID = Pounds-per-Square-Inch (differential pressure)

PSIG = Pounds-per-Square-Inch (gauge pressure)

SCI = Serial Communication Interface

SCP = Model CVMA System Control Panel (i.e., used to control up to 3 CenTraVacs with UCPs)

UCP = Microcomputer-based, UCP695 Chiller Control Panel for CenTraVacs

Warnings and Cautions

Notice that warnings and cautions appear at appropriate intervals throughout this manual. Warnings are provided to alert installing contractors to potential hazards that could result in personal injury or death, while cautions are designed to alert personnel to conditions that could result in equipment damage.

Your personal safety and the proper installation of this machine depend upon the strict observance of these precautions.

Unit Nameplate

The CVHE or CVHF unit nameplate is located on the left side of the unit control panel (UCP). A typical unit nameplate is illustrated in Figure 1. The following information is provided on the unit nameplate.

- Service model and size descriptor.
- Unit serial number
- Identifies unit electrical requirements
- List correct operating charges of CFC-11 or HCFC-123
- Lists unit test pressures and maximum operating pressures.
- Identifies unit Installation and Operation and Maintenance manual
- Product description block (identifies all unit components and unit "design sequence" (used to order literature and make other inquiries about the unit).
- Lists drawing numbers for unit wiring diagrams.

Mechanical Operation - CVHE

Overview

Each CVHE unit is comprised of 5 basic components: (1) the evaporator, (2) 3-stage compressor for the CVHE unit (3) water-cooled condenser, (4) 2-stage economizer, and (5) related interconnecting piping. A heat-recovery or auxiliary condenser can be factory-added to the basic unit assembly to provide a heat-recovery cycle.

Figure 2 illustrates a typical CVHE chiller.

Following are discussions of the unit's cooling-only and heat-recovery modes of operation. A pressure/enthalpy diagram (shown in Figure 3) is provided to further illustrate unit operation.

Cooling-Only Cycle.

When the CVHE is functioning in the cooling mode, liquid refrigerant is distributed along the length of the evaporator and sprayed through small holes in a distributor (i.e., running the entire length of the shell) to uniformly coat each evaporator tube. Here, the liquid refrigerant absorbs enough heat from the system water circulating through the evaporator tubes to vaporize.

The gaseous refrigerant is then drawn through the eliminators (which remove droplets of liquid refrigerant from the gas) and first-stage variable inlet guide vanes, and into the first stage impeller.

Note: Inlet guide vanes are designed to modulate the flow of gaseous refrigerant to meet system capacity requirements;

they also prerotate the gas, allowing it to enter the impeller at an optimal angle that maximizes efficiency at all load conditions.

Compressed gas from the first-stage impeller flows through the fixed, second-stage inlet vanes and into the second-stage impeller. Here, the refrigerant gas is again compressed, and then discharged through the third-stage variable guide vanes and into the third-stage impeller.

Once the gas is compressed a third time, it is discharged into the condenser. Baffles within the condenser shell distribute the compressed refrigerant gas evenly across the condenser tube bundle. Cooling tower water circulated through the condenser tubes absorbs heat from the refrigerant, causing it to condense. The liquid refrigerant then passes through orifice plate "A" and into the economizer.

The economizer reduces the energy requirements of the refrigeration cycle by eliminating the need to pass all gaseous refrigerant through 3 stages of compression. See Figure 4. Notice that some of the liquid refrigerant flashes to a gas because of the pressure drop created by the orifice plates, thus further cooling the liquid refrigerant. This flash gas is then drawn directly from the first (Chamber A) and second (Chamber B) stages of the economizer into the third- and second-stage impellers of the compressor, respectively.

Any remaining liquid refrigerant flows through another orifice plate "C" to the evaporator.

**Figure 2
Typical CVHE Unit
Assemblies**

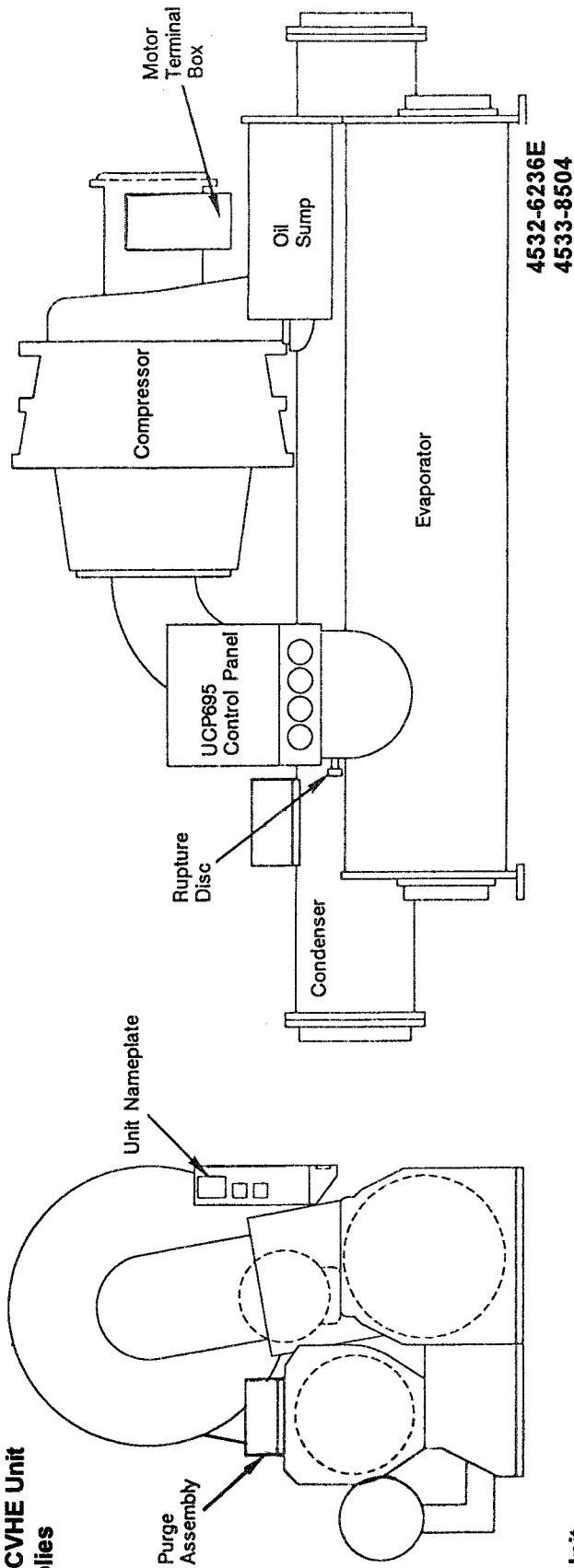

**CVHE Unit
w/Auxiliary or Heat-Recovery
Condenser**

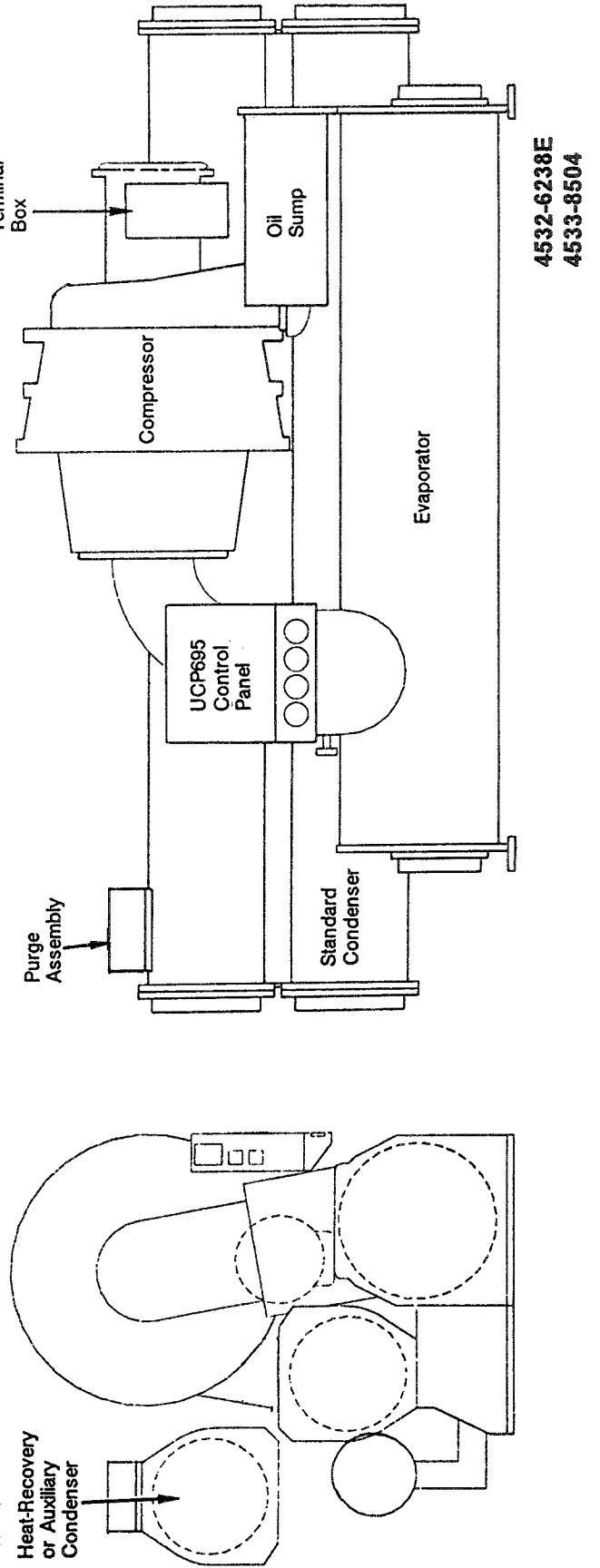

Figure 3
Pressure/Enthalpy Curve

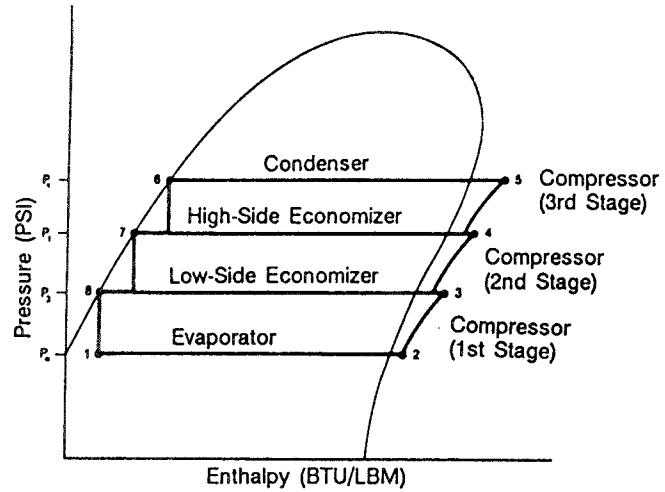
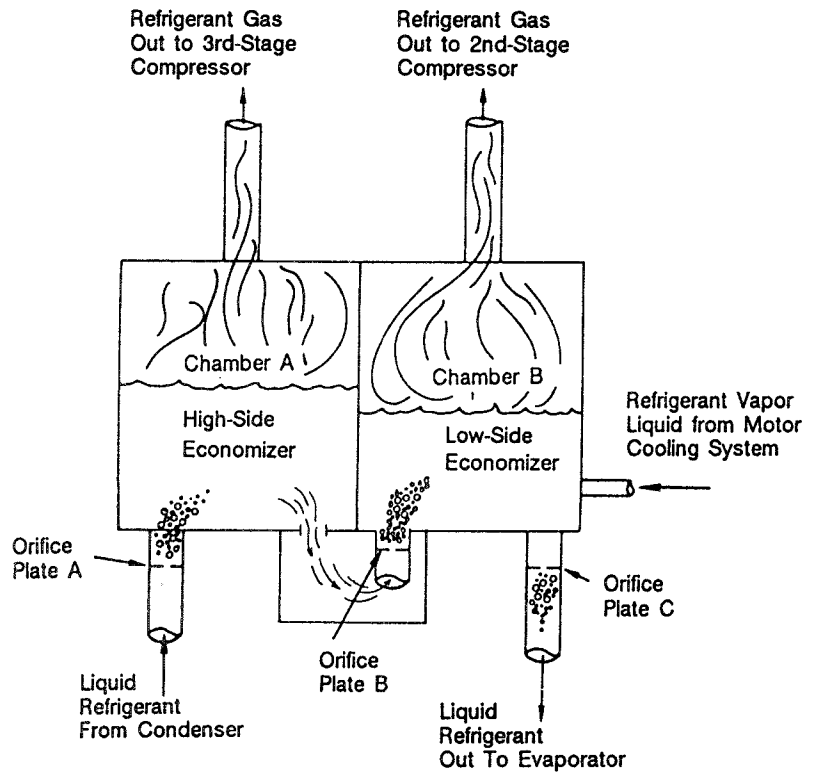

Figure 4
2-Stage Economizer



Compressor Lubrication System - CVHE

A schematic diagram of the compressor lubrication system is illustrated in Figure 5; this system supplies oil to the compressor motor bearings.

Oil is pumped from the oil tank (i.e. by a pump and motor located within the tank) through an oil pressure-regulating valve designed to maintain a net oil pressure of 12 to 18 psid. It is then filtered and sent to the compressor motor bearings. On later design CVHE and CVHF models, the oil filter assembly is equipped with refrigeration valves to isolate the filter during filter replacement.

From the bearings, the oil drains back to the oil tank through return lines.

WARNING:

Use caution while working on certain areas of the unit. Surface temperatures may exceed 150°F on the compressor discharge, oil tank (heater), oil filter, and oil lubrication lines.

To ensure proper lubrication and prevent refrigerant from condensing in the oil tank, a 1000-watt heater is secured to the oil tank exterior. Operating in response to a signal from the UCP, this heater energizes as needed to maintain 140° to 145 °F (60-63 C) when the chiller is not running. When the chiller is operating, the temperature of the oil tank is typically 115° to 160° F (46-72 C).

Refer to Figure 5; notice that the oil tank is vented between the compressor inlet vanes and the first-stage impeller suction cover. During normal system operation, motor barrel pressure is greater than that of the oil tank. Therefore, any gaseous refrigerant that enters the motor bearing cavities is drawn toward the oil tank where it is removed by the vent line.

A dual eductor system is used to reclaim oil from the suction cover and from the evaporator, and deposits it back into the oil tank. These eductors use high pressure condenser gas to draw the oil from the suction cover and evaporator back to the eductors, from the eductors the oil is discharged to the top of the oil tank.

Note: CVHEs utilize a time delay relay and solenoid valve that temporarily close the oil sump vent line during the chiller start sequence. This prevents the loss of oil pressure that can occur during start-up by isolating the oil sump from the low-pressure cavity at the opposite end of the sump vent line.

Liquid refrigerant is used to cool the oil supply to the inboard motor bearing on larger units (500-1250). Oil entering the oil cooler assembly from the oil tank (via the regulating valve and filter) flows into a coil inside the cooler shell. See Figure 6. As the oil passes through this coil, it is cooled by a mixture of gaseous and liquid refrigerant that surround the coil exterior.

Once the cooled oil leaves the cooler shell, it flows directly to the inboard motor bearing, and eventually returns to the oil tank.

The oil cooler is piped into the return circuit of the motor cooling system. Part of the refrigerant that is used to cool the compressor motor passes through the oil cooler shell on its way to the economizer.

Motor Cooling System

CVHE compressor motors are cooled with liquid refrigerant; see Figure 5 for a schematic illustration of this pressurized system.

Liquid refrigerant flows from the condenser sump to the bottom of the compressor motor, Figure 7, where it enters the motor chamber through a control orifice. As the liquid refrigerant touches the warmer motor components, a portion of it flashes to a gas and cools the motor. This "flash" gas, along with any excess liquid refrigerant, then drains to the second-stage of the economizer.

Because of the positive pressure differential between the condenser and economizer, proper refrigerant flow through the motor is maintained at all load conditions.

**Figure 5 - CVHE
Compressor Lubrication and
Motor-Cooling Systems**

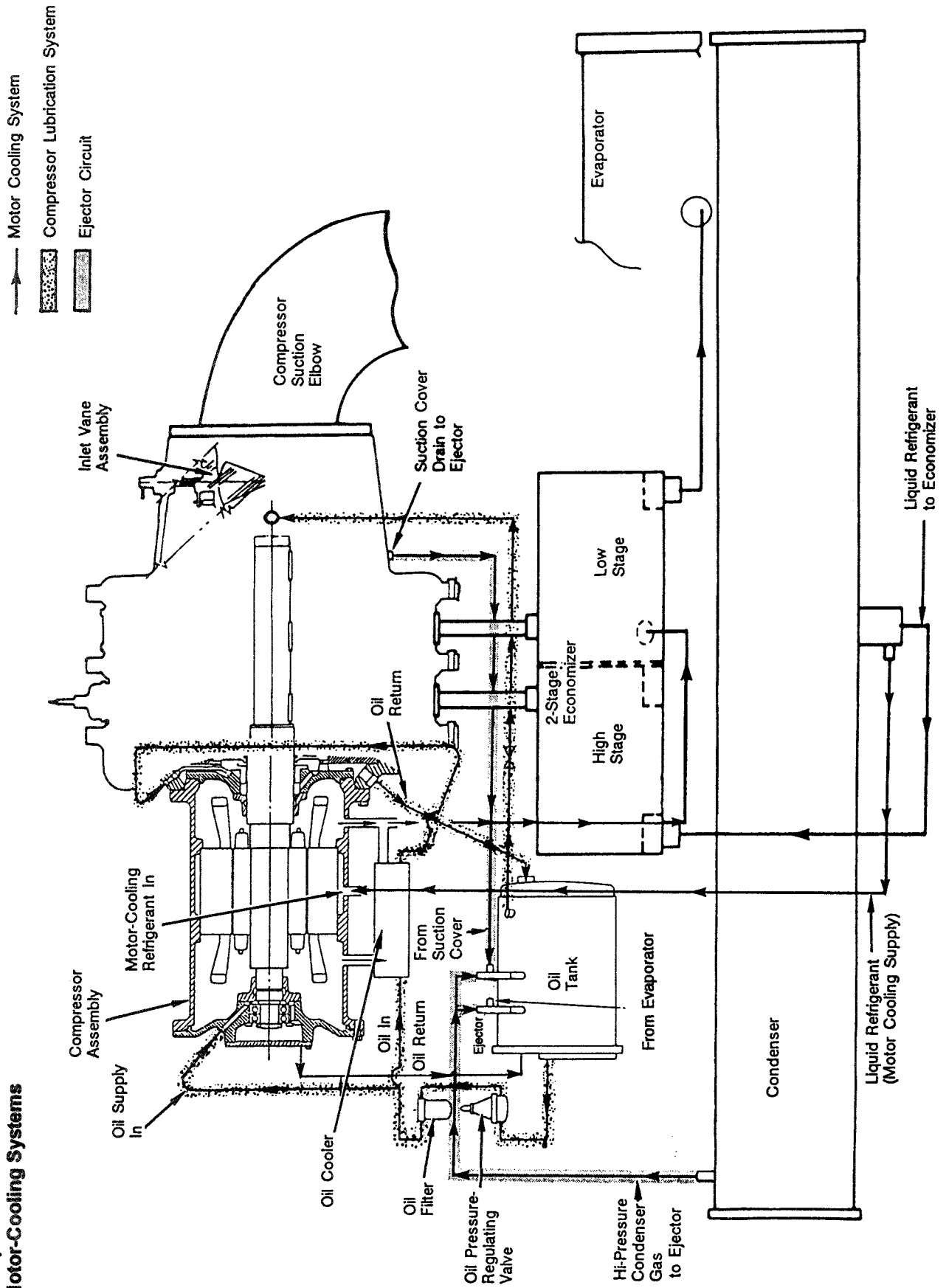
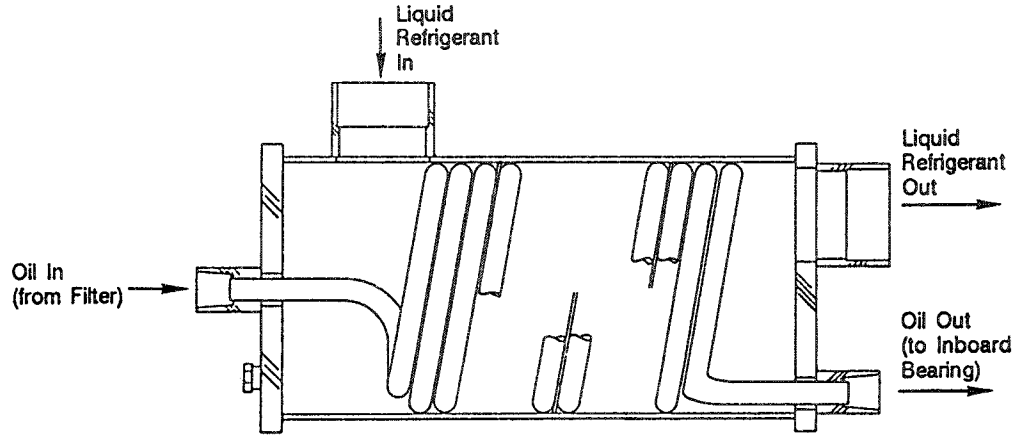
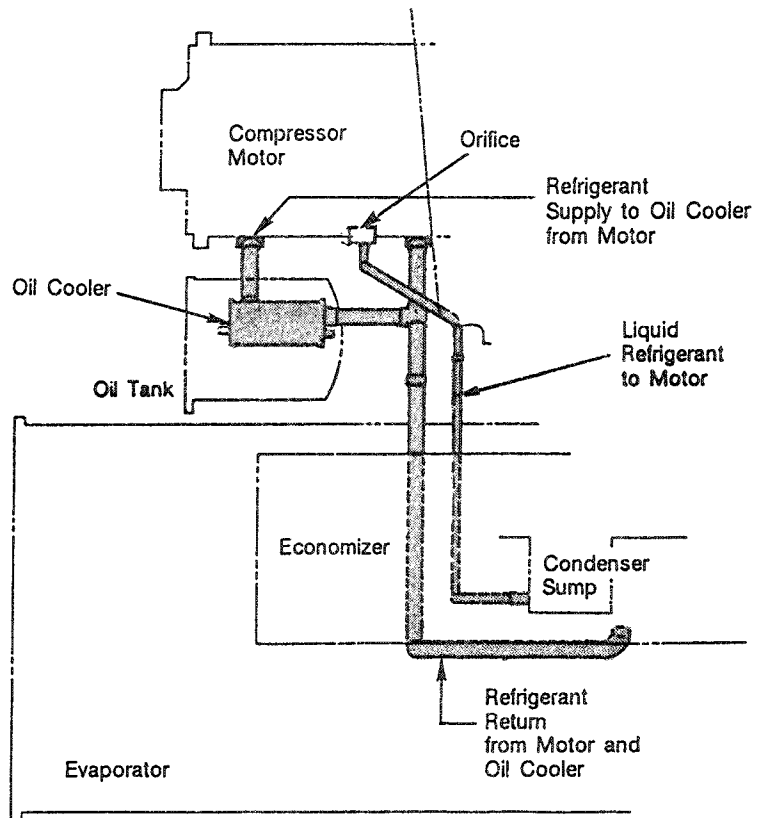

Figure 6
CVHE/CVHF Oil Cooler Assembly



4532-2900-41

Figure 7
CVHE Motor Cooling System



4533-0798

Mechanical Operation - CVHF

Overview

The following description applies to the Trane Model CVHF centrifugal chiller only. Refer to the appropriate operation manual for refrigeration cycle descriptions of other models.

Each CVHF unit is composed of 5 basic components:

- the evaporator;
- 2-stage compressor ;
- water-Cooled condenser;
- single-stage economizer, and;
- related interconnecting piping.

A heat-recovery or auxiliary condenser can be factory-added to the basic unit assembly to provide a heat-recovery cycle.

Figure 8 illustrates the general component layout of a typical CVHF chiller.

CVHF cooling-only and heat recovery modes of operation are described in the following sections. A pressure/enthalpy diagram (shown in Figure 9) is provided to further illustrate unit operation.

Cooling-Only Cycle

When the CVHF is functioning in the cooling mode, liquid refrigerant is distributed along the length of the evaporator and sprayed through small holes in a distributor (i.e., running the entire length of the shell) to uniformly coat each evaporator tube. Here, the liquid refrigerant absorbs enough heat from the system water circulating through the evaporator tubes to vaporize.

The gaseous refrigerant is then drawn through the eliminators (which remove droplets of liquid refrigerant from the gas), first-stage variable inlet guide vanes, and into the first-stage impeller.

Note: Inlet guide vanes are designed to modulate the flow of gaseous refrigerant to meet system capacity requirements; they also prerotate the gas allowing it to enter the impeller at an optimal angle that maximizes efficiency at all load conditions.

Compressed gas from the first-stage impeller is discharged through the second-stage variable guide vanes and into the second-stage impeller. Here, the refrigerant gas is again compressed, and then discharged into the condenser.

Baffles within the condenser shell distribute the compressed refrigerant gas evenly across the condenser tube bundle. Cooling tower water, circulated through the condenser tubes, absorbs heat from the refrigerant, causing it to condense. The liquid refrigerant then flows out of the bottom of the condenser, passing through an orifice plate and into the economizer.

The economizer reduces the energy requirements of the refrigeration cycle by eliminating the need to pass all gaseous refrigerant through both stages of compression. See Figure 10. Notice that some of the liquid refrigerant flashes to a gas because of the pressure drop created by the orifice plate, thus further cooling the liquid refrigerant. This flash gas is then drawn directly from the economizer into the second-stage impellers of the compressor. The remaining liquid refrigerant flows out of the economizer, passes through another orifice plate and into the evaporator.

Free Cooling, heat Recovery and Auxiliary Condenser Cycles

Refer to the CVHF section of Mechanical Operation.

Figure 8
General Component Identification -
Trane CVHF

End View

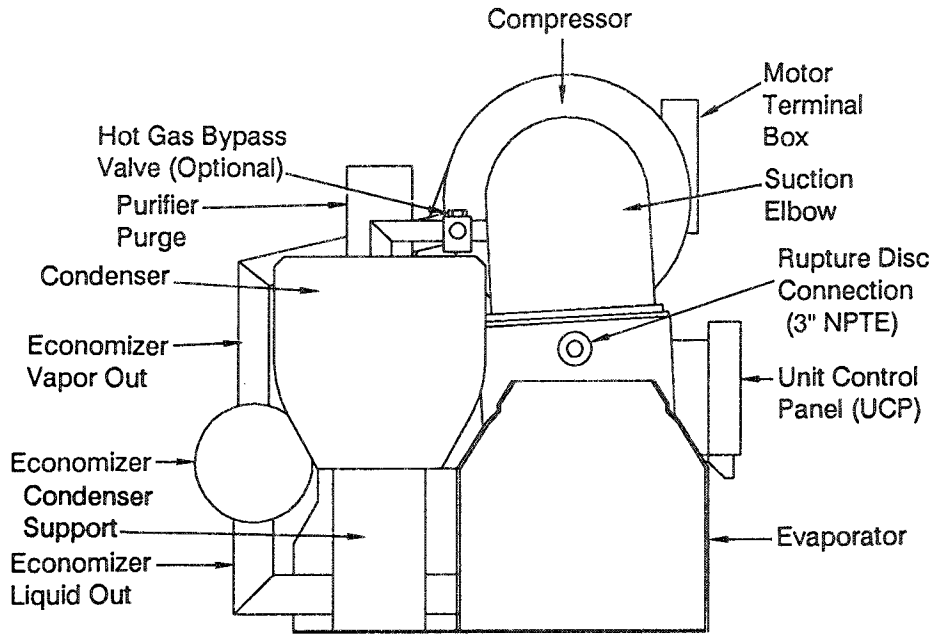

Front View

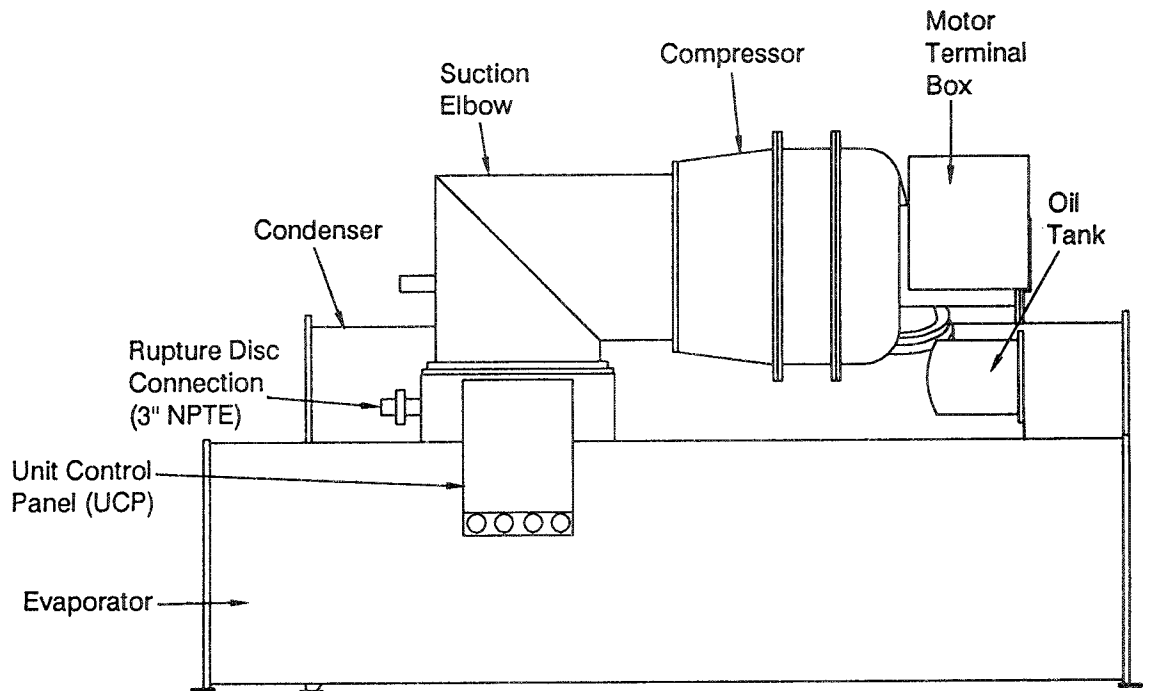

Figure 9
CVHF Pressure/Enthalpy Curve

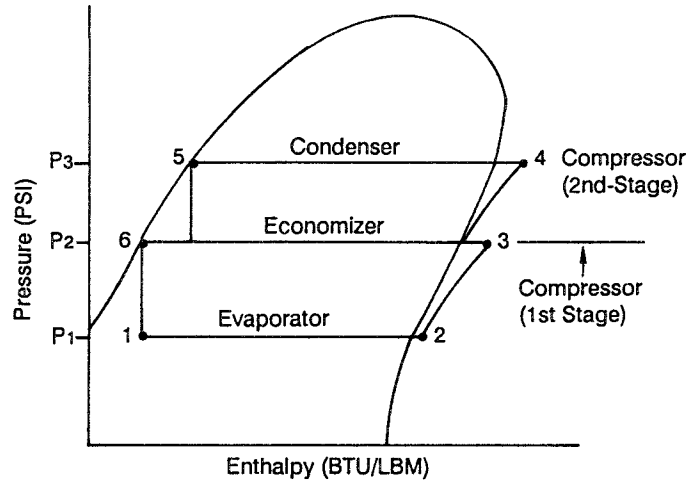
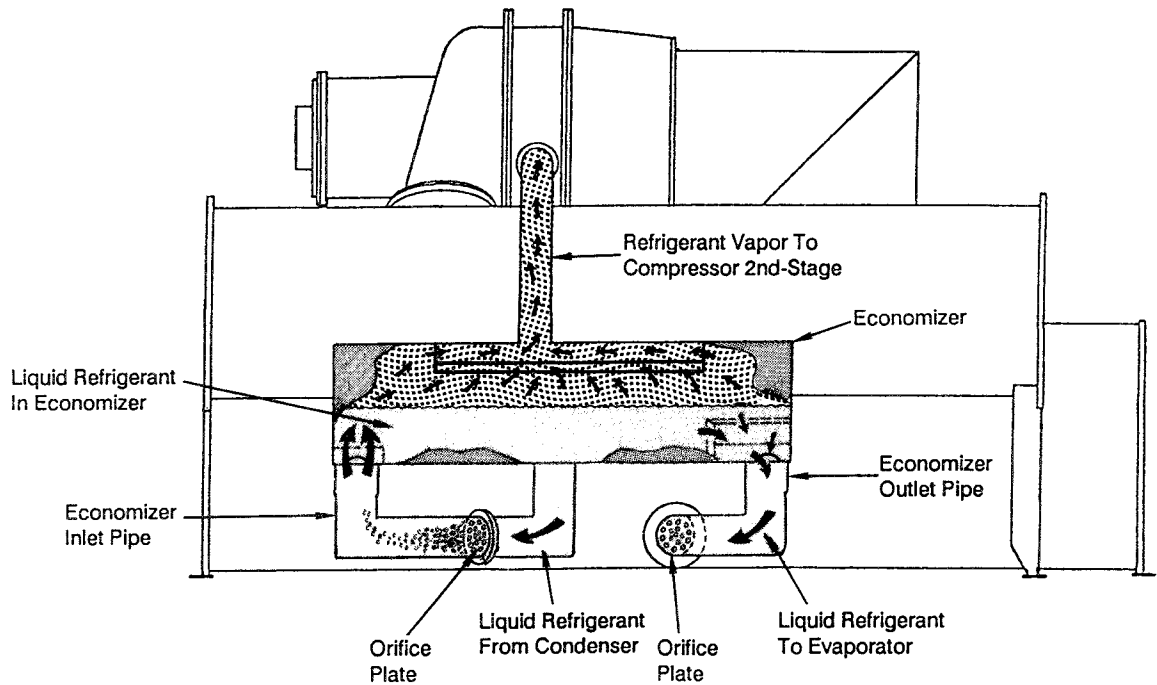

Figure 10
CVHF Economizer Operation



Compressor Lubrication System - CVHF

The CVHF compressor lubrication system, which supplies oil to the compressor motor bearings, is illustrated in Figure 11.

Oil is pumped from the oil tank (i.e., by a pump and motor located within the tank) through an oil pressure-regulating valve designed to maintain a net oil pressure of 12 to 18 psid. It is then filtered and sent to the compressor motor bearings. The oil filter assembly is equipped with refrigeration valves to isolate the filter during filter replacement.

From the bearings, the oil drains back to the oil tank through return lines.

To ensure proper lubrication and prevent refrigerant from condensing in the oil tank, a 1000-watt heater is secured to the oil tank exterior. Operating in response to a signal from the UCP, this heater energizes as needed to maintain an oil tank temperature of 140 to 145 F (60-63 C) when the chiller is not running. When the chiller is operating, the temperature of the oil tank is typical 115 to 160 F (46-72 C).

WARNING:

Use caution while working on certain areas of the unit. Surface temperatures may exceed 150° F on the compressor discharge, oil tank (heater), oil filter, and oil lubrication lines.

The oil tank is vented between the compressor inlet vanes and the first-stage impeller suction cover. During normal system operation, motor barrel pressure is greater than that of the oil tank. Therefore any gaseous refrigerant that enters the motor bearing cavities is drawn toward the oil tank where it is removed by the vent line.

A dual eductor system is used to reclaim oil from the suction cover and from the evaporator, and deposits it back into the oil tank. These eductors use high pressure condenser gas to draw the oil from the suction cover and evaporator back to the eductors, from the eductors the oil is discharged to the top of the oil tank.

Note: CVHFs utilize a time delay relay and solenoid valve that temporarily close the oil sump vent line during the chiller start sequence. This prevents the loss of oil pressure that can occur during start-up by isolating the oil sump from the low-pressure cavity at the opposite end of the sump vent line.

Liquid refrigerant is used to cool the oil supply to the inboard motor bearing. Oil entering the oil cooler assembly from the oil tank (via the regulating valve and filter) flows into a coil inside the cooler shell. As the oil passes through this coil, it is cooled by a mixture of gaseous and liquid refrigerant that surround the coil exterior. Once the cooled oil leaves the cooler shell, it flows directly to the inboard motor bearing, and eventually returns to the oil tank.

The refrigerant-side of the oil cooler is piped into the return circuit of the motor cooling system. Part of the refrigerant that is used to cool the compressor motor passes through the oil cooler shell on its way to the economizer.

Motor Cooling System

CVHF compressor motors are cooled with liquid refrigerant. This pressurized cooling system is illustrated in Figure 12.

Liquid refrigerant flows from the condenser sump to the bottom of the compressor motor where it enters the motor chamber through a control orifice. When the liquid refrigerant contacts the warmer motor components, a portion of it flashes to a gas and cools the motor. This "flash" gas, along with any excess liquid refrigerant, then drains to the evaporator sump.

Because of the positive pressure differential between the condenser and evaporator, proper refrigerant flow through the motor is maintained at all load conditions.

Figure 11
CVHF Motor Lubrication

Left End View

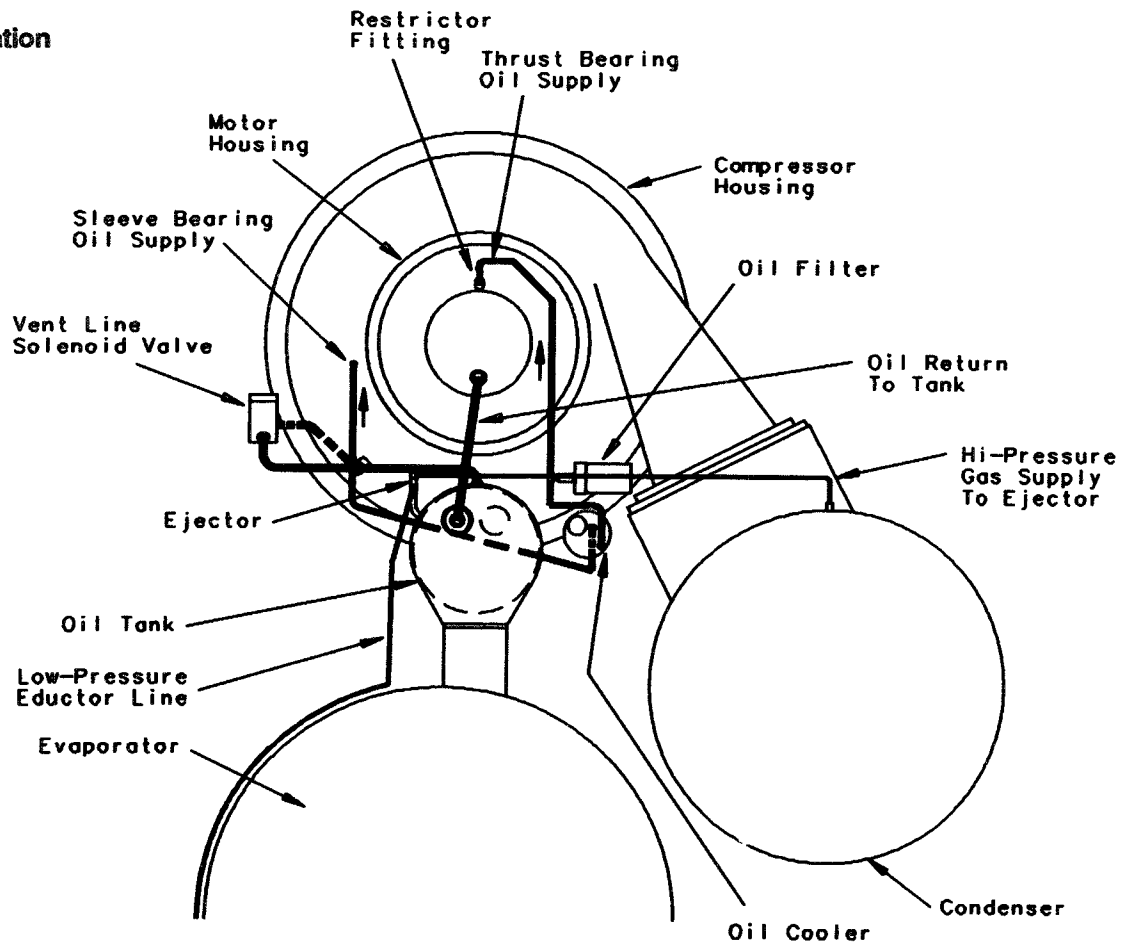

Back View

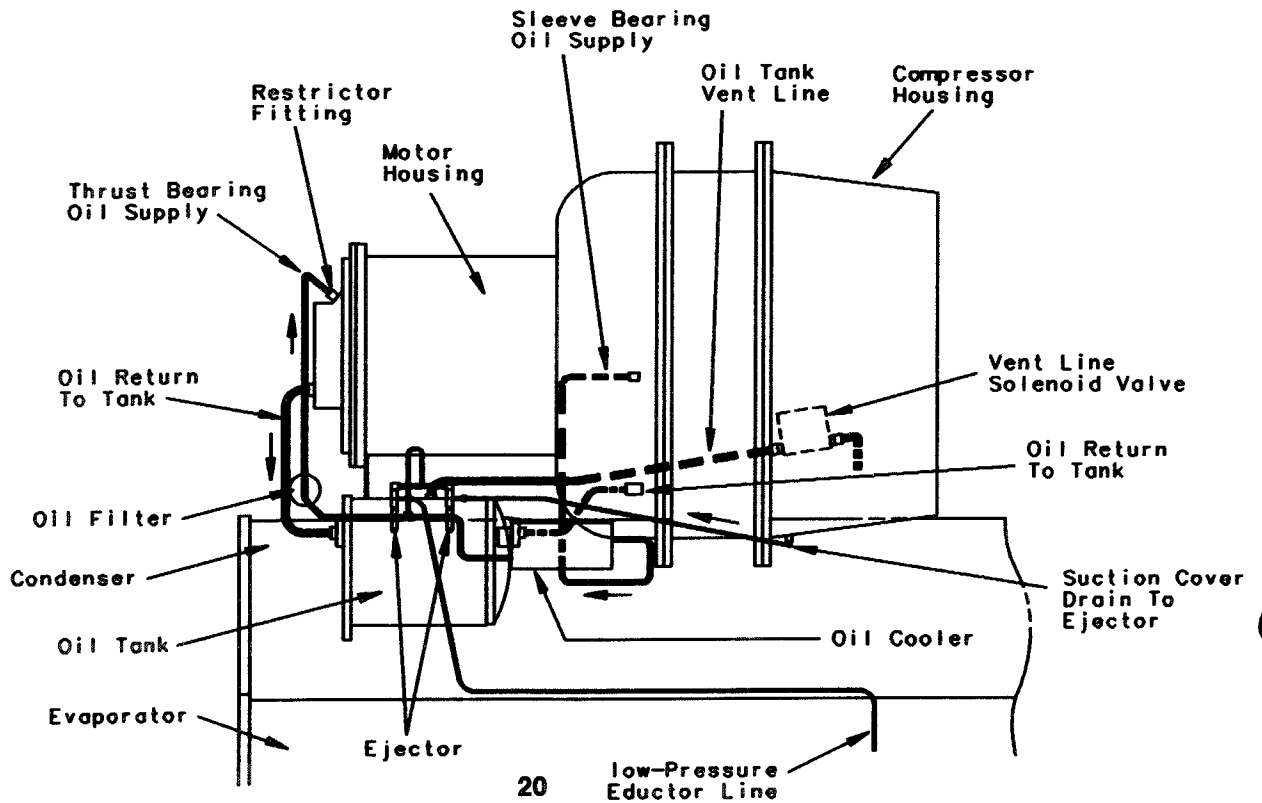
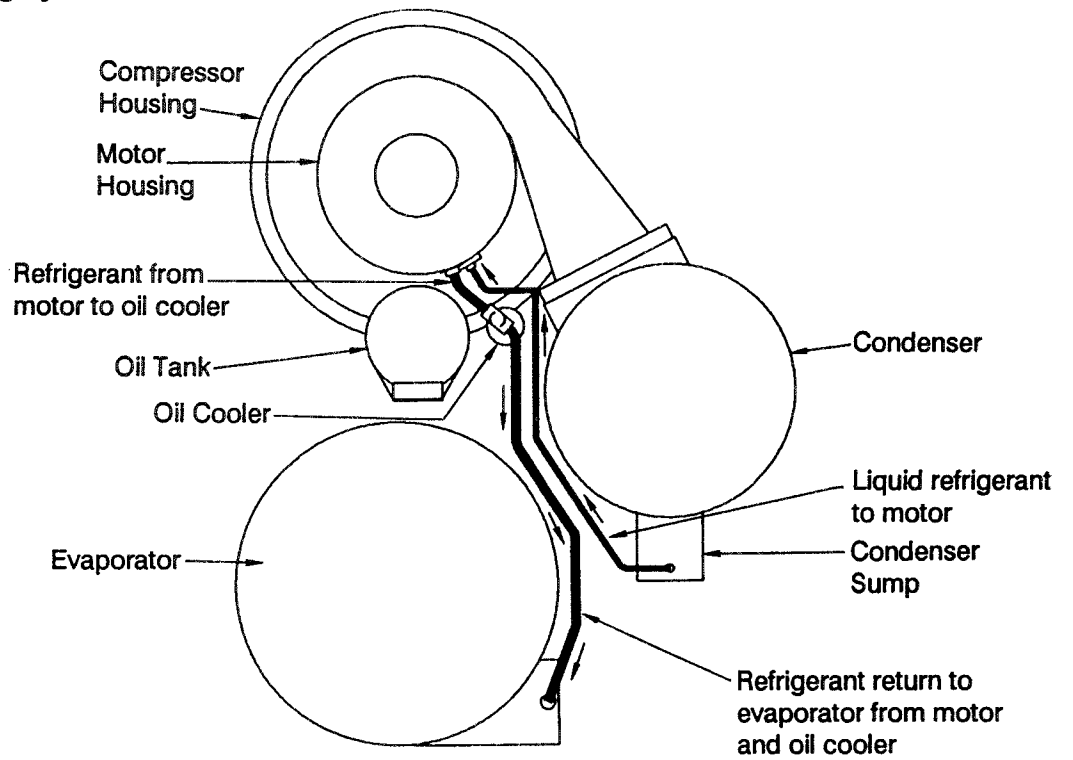
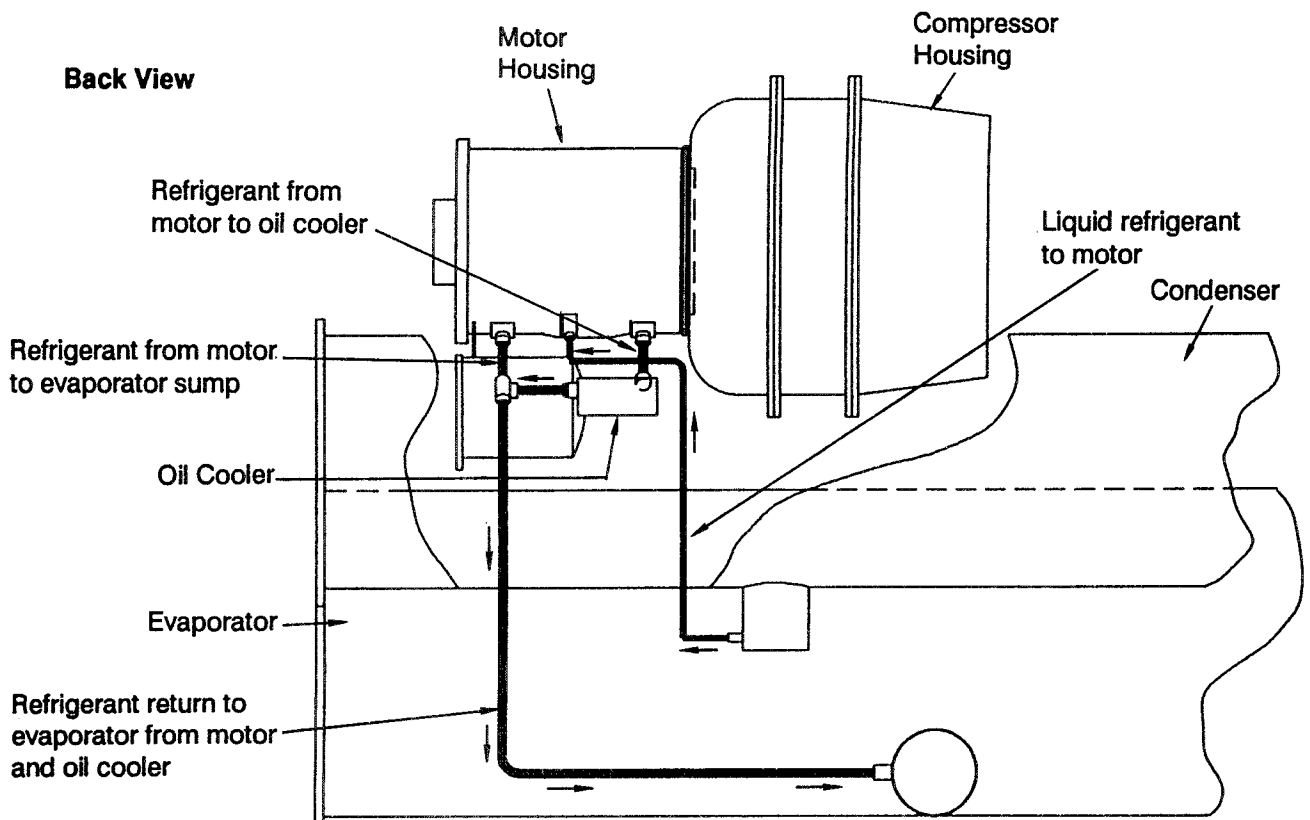

Figure 12
CVHF Motor Cooling System

Left End View



Back View



Free Cooling Cycle (Optional)- CVHE/CVHF

Based on the principle that refrigerant migrates to the coldest area in the system, the free cooling option adapts the basic chiller to function as a simple heat exchanger. However, it does not provide control of the leaving chilled water temperature.

If condenser water is available at a temperature lower than the required leaving chilled water temperature, the operator manually stops the compressor and starts the free cooling cycle by moving the free cooling switch to the "On" position. This optional switch on the unit control panel is illustrated in the "Chiller Control System" manual.

Several components must be factory-supplied or -installed to equip the unit for free cooling operation:

- a refrigerant gas line, including an electrically-actuated shutoff valve, between the evaporator and condenser;
- a valved liquid return line, including an electrically-actuated shutoff valve, between the condenser sump and the evaporator;
- a liquid refrigerant storage vessel;
- additional refrigerant; and,
- a free cooling selector switch on the unit control panel.

When the chiller operator initiates changeover to the free cooling mode, the shutoff valves in the liquid and gas lines open; UCP (i.e., unit control panel) control logic prevents the compressor

from energizing. Liquid refrigerant then drains (by gravity) from the storage tank into the evaporator and floods the tube bundle. See Figure 4.

Since the temperature and pressure of the refrigerant in the evaporator are higher than in the condenser (i.e., because of the difference in water temperature), the refrigerant in the evaporator vaporizes and travels to the condenser. Cooling tower water causes the refrigerant to condense, and it flows (again, by gravity) back to the evaporator.

This compulsory refrigeration cycle is sustained as long as a temperature differential exists between condenser and evaporator water. The actual cooling capacity provided by the free cooling cycle is determined by the difference between these temperatures which, in turn, determines the rate of refrigerant flow between the evaporator and condenser shells.

If the system load exceeds the available free cooling capacity, the operator must manually initiate changeover to the mechanical cooling mode by adjusting the free cooling switch to the "Off" position. The gas and liquid line valves then close and compressor operation begins. Refrigerant gas is drawn out of the evaporator by the compressor, where it is then compressed and discharged to the condenser.

Most of the condensed refrigerant initially follows the path of least resistance by flowing into the storage tank. This tank is vented to the economizer sump through a small bleed line; when the storage tank is full, liquid refrigerant must flow through the bleed line restriction. Because the pressure

drop through the bleed line is greater than that of the orifice flow control device, the liquid refrigerant flows normally from the condenser through the orifice system and into the economizer.

Note: During changeover from free cooling to mechanical cooling, the refrigerant transfer process is completed within 3 minutes. The micro-computer-based control system prevents carry-over by not allowing the unit to load for a period of two minutes.

Heat Recovery Cycle (Optional)

"Heat recovery" is designed to salvage the heat that is normally rejected to the atmosphere through the cooling tower, and put it to beneficial use.

For example, a high-rise office building may require simultaneous heating and cooling during the winter months. With the addition of a heat recovery cycle, heat removed from the building cooling load can be transferred to areas of the building that require heat. (Keep in mind that the heat recovery cycle is only possible if a cooling load exists to act as a heat source.)

To provide a heat recovery cycle, a heat-recovery condenser is added to the unit; see Figure 2. Though physically identical to the standard cooling condenser, the heat-recovery condenser is piped into a heating circuit rather than to the cooling tower.

During the heat recovery cycle, the unit operates just as it does in the "cooling only" mode except that the cooling load heat is rejected to the heating water circuit rather than to the cooling tower water circuit.

When hot water is required, the heating water circuit pumps energize. Water circulated through the heat-recovery (or auxiliary) condenser tube bundle by the pumps absorbs cooling-load from the compressed refrigerant gas discharged by the compressor. The heated water is then used to satisfy heating requirements.

Auxiliary Condensers

Unlike the heat-recovery condenser (which is designed to satisfy comfort heating requirements), the auxiliary condenser serves a preheat function only, and is used in those applications where hot water is needed for use in kitchens, lavatories, etc. While the operation of the auxiliary condenser is physically identical to that of the heat-recovery condenser, it is comparatively smaller in size, and its heating capacity is not controlled.

Trane does not recommend operating the auxiliary condenser alone because of its small size.

Chiller Control System

Unit Control Panel

CVHE and CVHF safety and operating controls are housed in the UCP 695 unit control panel. (Panel layout is illustrated in Figure 13.)

Based on control function, the UCP695 panel can be partitioned into 2 major "sections":

1. The "microcomputer-based" controls, which include the relay output module (1U1), power supply output module (1U2) and micro module (1U3); and,

2. The electromechanical control devices (e.g., pressure switches, gauges, counters.)

Major components within each of these control groups are described below.

Relay Output Module (1U1)

Consisting of terminal strip 1TB1, this module allows control of the following electrical circuits using relay contact closures:

- vanes open;
- vanes close;
- condenser water pump;
- purge;
- "head relief" request ;
- alarm relay ; and,
- free cooling and auxiliary free cooling relays (optional).

Connection points of standard and optional UCP (i.e., Unit Control Panel) output signals are indicated on the typical electrical schematic provided in the Electrical Sequence of Operation section of this manual.

Power Supply Output Module (1U2)

Like 1U1, power supply output module 1U2 also uses relay contact closures to enable UCP control of the following electrical circuits on 1TB2:

- reset relay;
- stop relay;
- overload relay;
- compressor start relay;
- transition relay; and,
- oil heater and oil pump relays.

Figure 13
UCP695 Control Panel
Layout - CVHE/CVHF

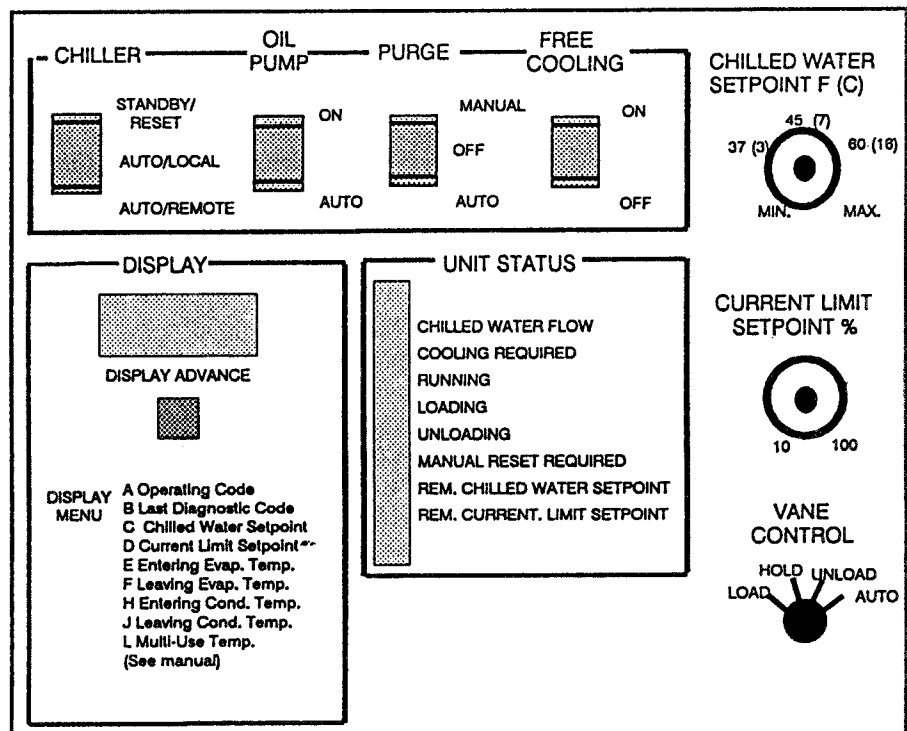

Micro Module (1U3)

Consisting of terminal strips 1TB6, 1TB3 and 1TB4, the input portion of this module "accepts" signals from a variety of standard sensor sources:

- leaving chilled water and evaporator refrigerant temperature sensors;
- chilled water and condenser water flow interlock circuits;
- "vane actuator closed" limit switch;
- differential oil pressure switch;
- 3-phase current signals from the auxiliary current transformers;
- oil and motor winding temperature sensors.

(Figure 14 illustrates the relative locations of the sensors that provide 1U3 with temperature inputs.) Figure 15 shows assembly of Temperature Sensor.

Based on these inputs, micro module 1U3:

- a. executes the start and stop sequence;
- b. Controls chilled water temperature in response to the setpoint by modulating the position of the inlet guide vanes;
- c. Monitor's key chiller operating parameters and "acts" to prevent the chiller from reaching and shutting down on an operating limit;
- d. Provide compressor/motor protection.

The human (operator) interface portion of micro module 1U3 is composed of a display window, a display advance pushbutton, status indicator lights, and a series of control knobs and switches. These devices enable the

operator to establish chiller control settings, and monitor chiller operating and diagnostic conditions.

Additional information on these components is provided later in this section under "Operator Interface: and "Service Interface".

In addition to the standard micro module features just described, 2 mutually exclusive control options are also available at the micro module level:

1. **Serial Communications Interface Link (SCI). (Optional)**
The SCI provides an intelligent interface with a Trane SCP (System Control Panel), allowing the chiller to accept set points and commands from a remote location, and communicate condition and diagnostic information to the SCP.
2. **Chilled Water Reset (CWR). (Optional)**
CWR enables the UCP to reset the chilled water setpoint based on load (i.e., evaporator return water temperature) or ambient temperature. (See the Control Options section for further information.)

Electromechanical Controls

Other control devices installed in the unit control panel (but separate from the microcomputer-based controls) are described below.

See Table 1 for control cut-in and cutout points. (Unit time delays and nominal fault time-out periods are also included therefore fore your reference.)

Condenser high Pressure Cutout Switch (1S1)

This 2-position, normally closed switch monitors the pressure in the condenser. (See Table 1 for control set points.)

Differential Oil Pressure Switch (1S2) Connected between the down stream side of the oil filter

and the oil sump, this SPST, normally open switch closes when the pressure differential reaches the point indicated in Table 1.

Hour Meter (1M1)

Mounted on the left-hand side of the control panel enclosure, the non-resettable hour counter accumulates running hours from the time of initial unit start-up. It displays a maximum value of 99999.9 hours before returning to zero.

Start Counter (1M2)

Accumulating compressor motor starts from the time of initial unit start-up, this nonresettable counter displays a maximum value of 99999 compressor starts before starting over. Like the hour meter, it is mounted on the left-hand side of the control panel enclosure.

Pressure Gauges

Four pressure gauge dials are mounted across the lower front of the unit control panel. These dials enable the operator to monitor oil sump (low), oil supply (high), evaporator and condenser pressures.

Advanced Motor Protection

This control package provides the UCP with the features needed to protect the compressor motor from momentary power losses, phase imbalance, phase reversals, and surge (i.e., see note below) by initiating a unit shutdown whenever one of these situations occurs.

Diagnostic codes for each of these conditions appear at the display window to enable the operator to identify which particular electrical abnormally occurred.

Note: The UCP will allow the chiller to operate under "surge" conditions (operating code A.78) for 15 minutes before shutting it down on latching diagnostic b.d.A.

Figure 14
Micro Module (1U3)
Temperature Sensor Locations

1. For sensor installation instructions, see the installation manual that shipped with the unit. (Sensor electrical connections are shown on the electrical schematic in Figure 15; see Lines 61 through 81.)

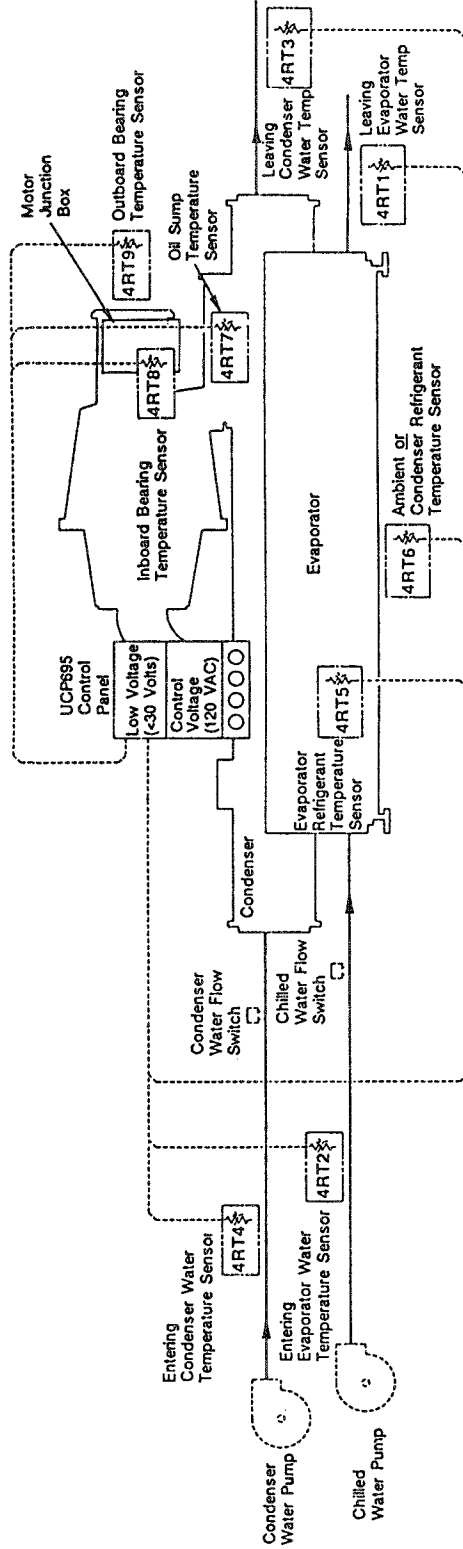

X39470473E

Figure 15
Temperature Sensor Assembly

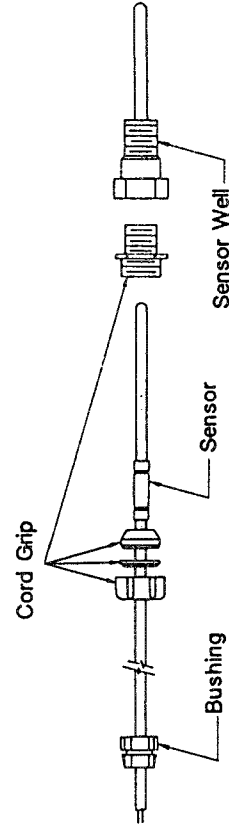

4533-1710E
 X13790057

Table 1
Unit Time Delays and Safety Control Cutout Settings

Notes:

1. See tables 3 and 4 for complete code listing.
2. Since prelube timing can begin at any point during 33- second "oil pressure overdue" interval, actual elapsed time to "establish oil pressure" and "prelube" can be anywhere from 15 to 48 seconds.
3. The 165 F inhibit applies only when unit is first powered-up, or if chiller switch is turned from STANDBY/RESET to AUTO/ LOCAL or to AUTO/REMOTE. Otherwise, 30 minutes must elapse between compressor starts.
4. Operating code **A 9** will appear on operator display only when free cooling valve limit switches have opened.
5. See "Electrical Sequence of Operation". Refer to Purifier Purge Operation Manual for details.
6. Reset at 3S6 or 6S6 on purge panel.
7. This timer closes sump vent line during prelube and during unit start sequence.
8. Fixed differential of 3-6 psid for switch closure on a rise in differential oil pressure.

Operating Controls: "Timers"	Timing Interval	System Reset	Operating Code (1)
Prelube (2)	15 seconds	n/a	A 72
Restart Inhibit (3):			
Winding Temp. <165 F (74 C)	2 minutes	n/a	A 70
Winding Temp. ≥ 165 F	15 minutes	n/a	A 70
Since Last Start	30 minutes	n/a	A 70
Post-Lube	2 minutes	n/a	A 79
Free-Cool/Vane Open Inhibit (4)	3 minutes	n/a	A 9
Purifier Purge: (purge switch @ AUTO)	Controlled by purge timer (6)	manual (7)	n/a
Sump Vent-Line Interval (8)	100 seconds	n/a	n/a
Safety Controls: Fault Time-Outs	Timing Interval	System Reset	Diagnostic Code (1)
Oil Pressure Overdue (2)	33 seconds	manual	b F2
Transition Complete Overdue	2 seconds	manual	b FO
Transition-from-Start Complete	Max. accel. timer setting	manual	b EE
Condenser Water Flow Overdue	3 minutes	manual	b dC
No Evaporator Water Flow	2 seconds max. w/o flutter	auto	b Ed
Vane Closure Overdue	3 minutes	manual	b FA
Free-Cool Valve Closure Overdue	3 minutes	manual	b F9
Surge	15 minutes	manual	b dA
Safety Controls: Unit Cutouts	Control "Trip" Point	System Reset	Diagnostic Code (1)
Winding Temp. Run Inhibit	265 ± 15 F* 130 ± 9 C*	manual	b E7
Low Oil Temp. Run Inhibit	100± 2 F 38+ 1C	auto	b F3
High Oil Temp. Run Inhibit	180± 2 F 83+ 1C	manual	b F4
High Bearing Temp. Run Inhibit (Optional)	180± 2 F 83+ 1C	manual	b EA, Eb
Lvg. Water Temp. Low Limit (Std. Range)	35± 1 F 2+ .5 C	auto	n/a
Differential Oil Pressure Switch —	Closes 11.5 - 15 psid Opens 9+ 1 psid	manual	b E8
High Pressure Cutout Switch —	Std. Units 15± 1 psig ASME Units 25+ 1 psig (9)	manual	b F5
Oiless Purge "Extend Run" Press. Switch —	Closes 20 psig Opens 25 psig	n/a	n/a

Operator Interface

Monitoring devices and all chiller control components requiring adjustment for normal chiller, operations are accessible without opening the unit control panel door. These components that area part of micro module 1U3 are illustrated in Figure 13 and discussed below.

Chiller Switch

Located above the "Display" block on the UCP, this 3-position switch enables the owner/operator to define chiller control:

Standby/Reset. When power is applied to the unit with the chiller switch set at "Standby/Reset", the UCP is activated but unit operation is prohibited; operating code A Q appears on the display.

This switch position can be used by all the operator or service technician to clear a latching diagnostic (i.e., fault that requires manual reset), or to shut down the unit.

Auto/Local. This switch position allows the chiller to run automatically, using the operational setpoints set at the unit.

Auto/Remote. With the chiller switch in this position, the unit runs automatically using the setpoints established at a remote device and communicated to the chiller with the optional serial communication-interface (SCI).

If no setpoints are sent by the remote controller, the UCP uses the operational setpoints set at the unit control panel.

Note: When the unit is equipped with the SCI option, a remote device can place the unit in the "Standby/Reset" mode even though the chiller switch is positioned at "Auto/Remote". However, a latching diagnostic condition at the unit cannot be cleared from a remote device.

Oil Pump Switch

A 2-position oil pump switch is located to the right of the chiller switch, above the display window. Switch position functions are described below:

On. This switch position provides continuous operation of the oil pump, even when the chiller switch is positioned at "Standby/Reset".

Note: The "On" switch position is designed for use by service personnel only; do not leave it in this position! Compressor start-up will not occur if the oil pump switch is set at "On" (i.e., latching diagnostic b E8 will flash alternately with operating code A 72 on the UCP's display).

Auto. Oil pump operation is controlled by the UCP, ensuring oil flow when the compressor is running. This is the normal switch operating position.

Purge Switch

Located next to the oil pump switch (see Figure 14), the purge switch enables the owner/operator to select 1 of 3 purge operational modes.

Manual. This switch position provides continuous operation of the purge compressor regardless of centrifugal compressor operation, or the position of the chiller switch.

Off. Purge operation will not occur when the purge switch is set at this position.

WARNING: To prevent injury or death due to electrical shock, open unit disconnect switch before servicing to ensure purge unit is de-energized.

Auto. This is the normal switch operating position. With this switch set at AUTO, the purge will run when the CenTraVac is in powered cooling operation.

If the chiller switch is set at STANDBY/RESET and the purge switch is set at AUTO, the purge unit is also shut down.

Note: On those CVHE/CVHF units equipped with more than one condenser, purge only from the active condenser. Use the manual valves provided to isolate the inactive condenser.

Chilled Water Setpoint

Used to set the leaving chilled water temperature, this manually adjustable potentiometer is located at the right-hand side of the window in the control panel door. See Figure 13, notice that dial settings range from "Min" to "Max", with intermediate To view the front panel chilled water setpoint, adjust the vane control switch to "Hold" and press the "Display Advance" push-button until the "I" code prefix appears on the display. The integer value (in increments of 1F or 1 C) immediately to the right of "I" is the UCP's chilled water setpoint.

Remember that the standard chiller operating range is 37 F to 60 F, (3 to 60.8 C) while the temperature range for extended operation is 20 F to 70 F (-6 to 22 C.)

Note: To view the active chilled water setpoint, check the entry for code prefix "C" of the operator's menu. When the chiller switch is set at "Auto/Remote" and the "Remote Chilled Water Setpoint" status light is lit, the "C" value displayed was entered at a remote system control panel (SCP).

Current Limit Setpoint

Located directly below the chilled water setpoint control, this manually adjustable potentiometer is used to register the desired current limit setpoint. Dial settings range from 40% to 100% of the compressor rated-load-amps. (RLA) value.

To view the front panel current limit setpoint, adjust the van control switch to "Hold" and press the "Display Advance" push-button until the "-" code prefix appears. The integer value (indicated in increments of 1T) at the immediate right of "-" is the UCP's current limit setpoint.

Note: To check the active current limit setpoint, locate the entry displayed for code prefix "d" in the operator's menu. Whenever the chiller switch is set at "Auto/Remote" and the "Remote Current Limit Setpoint: status light is lit, the "d" value displayed was entered at a remote SCP.

Vane Control Switch

A 4-position, compressor inlet guide vane control switch is located beneath the current limit setpoint control. Each switch position is described below.

Load. As long as the vane control switch remains in this position, the "vanes open" (1U1Q7) relay is continuously energized and automatic vane control is suspended during the "Normal Run" mode (A 74).

Manual loading does not take precedence over the current limit (A 75), condenser limit (A 76) or evaporator limit (A 77) modes of operation.

Hold. With the vane control switch set at "Hold", both the "vanes open: (1U1Q7) and "vanes close" (1U1Q8) relays are de-energized, so the inlet guide vanes remain at their present position. In other words, automatic vane control is suspended when the chiller is operating in the "Normal Run" mode (A 74).

However, keep in mind that a current limit (A 75) condenser limit (A 76), or evaporator limit (A 77) operating mode will override the manual "Hold" setting.

Note: Positioning the vane control switch remains in this position, the "vanes close" relay (1U1Q8) is continuously energized; automatic vane control is suspended regardless of the chiller's operating mode.

Auto. Inlet guide vane position is automatically controlled by the UCP when the vane control switch is set at this normal operating position.

Free Cooling Switch (Optional)

Free cooling enables the chiller to function as a simple heat exchanger, using refrigerant as the working fluid; however, it does not provide control of the leaving chilled water temperature.

When condenser water is available at temperatures lower than the desired chilled water temperature, the free cooling option provides "average selection" chiller capacity without operating the compressor.

A 2-position free cooling switch, located next to the purge switch, allows the operator to select from 1 to 2 operating positions:

On. Placing the free cooling switch in this position forces the chiller to enter the free cooling mode (A 9) ; the compressor shuts down if the unit is operating in the powered cooling mode.

Note: Operating code A 9 appears on the display once the free cooling valves are open. (The unit cannot return to the powered cooling mode until these valves are closed.) Remember, too, that when the UCP is equipped with the SCI option, a remote device can "turnoff" free cooling operation while the free cooling switch is set at "On".

Off. This setting enables normal chiller operation within the parameters established for the powered cooling mode.

Unit Status Lights

A series of 8 status indicator lights are located directly below the purge switch. These blue lights along with the operating and diagnostic information found on the display allow the operator to monitor chiller operations. The

purpose of each status indicator light is described below.

Chilled Water Flow

Illumination of this light indicates that chilled water flow switch 5S2 is closed.

Cooling Required. This light only illuminates when the UCP proves chilled water flow and detects a cooling requirement (i.e., leaving chilled water temperature exceeds the chilled water setpoint by a value greater than the differential-to-start criteria).

Running. Illumination of this status light indicates that:

- the unit is running (or is in one of the "run" modes);
- the chiller switch is set at "Auto/Local" or "Auto/Remote"; and,
- the start sequence (or , "transition") is complete.

It also remains lit through the chiller's post-lube cycle after the compressor shuts down.

Loading. When this light glows, the UCP is loading the unit (i.e., the vane actuator is driving the vanes open).

Unloading. When this light is on, the UCP is unloading the unit (i.e., the vane actuator is driving the vanes closed).

Note: It is normal for the "Loading" and "Unloading" status lights to flash on and off in short pulses.

Manual Reset Required.

Illumination of this light indicates that the UCP detected a "latching diagnostic condition, and shut down the chiller. Operation cannot resume until the UCP is manually reset (i.e., chiller switch is

adjusted to "Standby/Reset", then back to "Auto/Local" or "Auto/Remote").

Remote Chilled Water Setpoint.

When this light is on, the UCP is ignoring its front panel setpoint, and is using the chilled water setpoint:

- determined by the optional chilled water reset module, or;
- entered at a remote source (e.g., an SCP699 system control panel, or a Trane BAS).

If remote communications are severed, the UCP "defaults" to the control value of its chilled water setpoint potentiometer.

Remote Current Limit Setpoint.

Illumination of this light indicates that the UCP is using a current limit setpoint communicated from a remote source (e.g., SCP or Trane BAS) , and is ignoring its from panel setpoint.

Again, if remote communications are interrupted, the UCP "defaults" to the control value set with the current limit setpoint potentiometer.

UCP Display

The UCP's display consists of a blue, 4-digit vacuum fluorescent display and a "Display Advance" push-button; both are located to the left of the unit status indicator lights. See Figure 13.

The first letter of the 4-character display identifies the type of data shown in the display window: a list of these indicator codes, along with their meanings, is provided in Table 2. An abbreviated version of this list also appears on the face of the UCP, directly below the "Display Advance" pushbutton. The two remaining alphanumeric characters of the display indicate

characters of the display indicate unit operating mode, diagnostic condition, setpoints or actual temperatures as defined by the code prefix. Refer again to Table 2, as well as to Tables 3 and 4.

Note: If the UCP detects a diagnostic condition, it alternately flashes the appropriate diagnostic code and unit operating mode (at the time of unit shutdown) on the display.

however, when the chiller switch is set at "Auto/Remote" and the applicable status indicator lights are on, the displayed setpoint values were established at a remote device (e.g., an SCP699 or Trane BAS).

Codes prefixed by a "C" or "d" are followed by the corresponding setpoint value (chilled water or current limit, respectively) presently used to control the chiller. If the chiller switch is set at "Auto/Local", the setpoint values displayed are those set manually at the UCP695 control panel.

"E", "F", "H" and "J" code prefixes are followed by an actual measurement of a system parameter (e.g., entering evaporator water temperature). (Code prefixes "E", "H" and "J" represent sensor options: if these sensors are not installed a bar (--) appears on the display.)

**Table 2
Display Menus**

Operator's Menu		Servicemans's Menu (1, 2)	
Code Prefix	Parameter Description	Code Prefix	Parameter Description (and Display Range)
A	Operating Mode (see Table 16)	A	Operating Mode (see Table 16)
b	Last Diagnostic (see Table 17)	b	Last Diagnostic (see Table 17)
C	Active Chilled Water Setpoint: Std. Range = 37-60 F (3-16 C) Extd. Range = 20-70 F (-6-22 C)	┐	Panel Chilled Water Setpoint (--, 20-70 F, --)(--, -6-22 C, --)
d	Active Current Limit Setpoint (40% thru 100% RLA)	—	Panel Current Limit Setpoint (--, 40% thru 100% RLA, --)
E	Entering Evap. Water Temp. (Opt.) (--, 12-91 F, --)(--, -11-33 C, --)	—	Evaporator Refrigerant Temp. (3) (b Ad, -4-42 F, --)(b Ad, -20-6 C, --)
F	Leaving Evap. Water Temperature (b Ab, 12-91 F, --)(b Ab, -11-33 C, --)	L	Control Response Setpoint (1 thru 237)
H	Entering Cond. Water Temp. (Opt.) (--, 28-142 F, --)(--, -2-62 C, --)	□	Start Differential Setpoint (2-10 F) ((-17 thru -12 C)
J	Leaving Cond. Water Temp. (Opt.) (--, 28-142 F, --)(--, -2-62 C, --)	P	Condenser Limit Setpoint (80-120% HPC)
L	Multi-Use Temperature (4) (--, -5-135 F, --)	U	Evap. Refg. Trip Setpoint (b A3) Std. Range = 29-34 F (-1 thru 1 C) Extd. Range = 0-34 F (-18 thru 1 C)

Notes:

1. To redefine the "operator's menu" to the "serviceman's menu" turn vane control switch to HOLD.
2. For additional information on any item listed in the "serviceman's menu", contact a qualified service organization.
3. Actual measured evaporator refrigerant temperature.
4. Examples of "Multi-Use Temp." applications are: Cond. Lvg. Refg. Temp.; CWR Ambient Temp.; CWR Temp. from Analog Input.

Figure 16
(Continued)

Adjusting the vane control knob to the "Hold" position redefines the display code prefixes to indicate the "local" (or front panel) chilled water and current limit spiniest, actual evaporator refrigerant temperature, and settings for control response, start differential condenser limit and evaporator refrigerant "trip" point as shown in Table 2.

Important! Do not leave selector knob in "Hold", control of leaving chilled water temperature will be suspended. Only "safeties" are functional!

Note: While in the "serviceman's menu", the integer values displayed for the panel chilled water, condenser limit and evaporator refrigerant trip setpoints represent the entire adjustment range for these potentiometers. Unless the chiller is specifically designed for "extended range" operation, the UCP will adhere to the operating parameters established for "standard range" chillers.

Use the "Display Advance" push-button to scroll from one menu entry to the next. Remember that a blank display marks the end of the "operator's menu"; to return to the top of the menu, simply press this push-button once.

Important! Advancing past the "Last Diagnostic Code" entry in either menu automatically clears the code registered there from the UCP's memory!

Service Interface

Following is a brief description of UCP control components that can only be accessed by opening the control panel door. Each of these divides, as illustrated in "Control Options", is set at initial unit start-up by a qualified service

technician.

WARNING: To prevent injury or death due to electrical shock, always open unit disconnect switch before opening control panel door.

CAUTION: To ensure proper chiller operation, never tamper with any UCP controls located behind the panel door without first consulting a qualified Trane service technician.

Table 3
Codes for Unit Operating Modes

3-Character Code	Operating Mode Description
Blank	Power Off
A 0	Standby/Reset
A 1	Auto (Local or Remote)
A 9	Free Cooling
A 70	Restart Inhibit
A 71	Establish Cond. Water Flow
A 72	Start
A 74	Run: Normal
A 75	Run: Current Limit (1)
A 76	Run: Condenser Limit (2)
A 77	Run: Evaporator Limit (3)
A 78	Run: Surge Condition
A 79	Post-Lube
A 88	Reset
A100	External Inhibit (Remote Start/Stop)

Notes:

1. As current limit setpoint is approached, 1U3 restricts further opening of the inlet guide vanes.
2. As condenser limit setpoint is reached, 1U3 restricts additional compressor loading to avoid shutdown on high condenser pressure (b F5) and initiates "head relief request" (i.e., optional relay).
3. 1U3 restricts further opening of the inlet guide vanes to avoid unit shutdown on low evaporator refrigerant temperature (b Fb).
4. 1U3 limits compressor loading and initiates "head relief request" (i.e., optional relay) when unit enters a surge condition. An automatic unit shutdown occurs if unit remains in surge for 15 minutes (b dA).

Table 4
Diagnostic Codes

Diag. Code	Diagnostic Explanation	Reset Type	Diag. Code	Diagnostic Explanation	Reset Type
b A3	Evaporator Refrig. Temp. Range	Manual	b E7	High Motor Temperature	Manual
b A4	Motor Temperature Sensor #1	Manual	b E8	Differential Oil Pressure Switch	Manual
b A5	Max. Acceleration Time Range	Manual	b E9	Stop Relay	Manual
b A7	Motor Temperature Sensor #2	Manual	b EA	High Inboard Brg. Temp. (Sen. #1)	Manual
b A8	Motor Temperature Sensor #3	Manual	b Eb	High Outbrd. Brg. Temp. (Sen. #2)	Manual
b A9	Oil Temperature Sensor	Manual	b EC	Running Overload	Manual
b Ab	Leaving Water Temp. Sensor	Manual	b Ed	Chilled Water Flow	Auto
b AC	Cond. Refrig. Pressure Sensor (3)	Manual	b EE	Max. Acceleration Time Exceeded	Manual
b Ad	Evap. Refrig. Temperature Sensor	Manual	b F0	Transition	Manual
b AE	Ambient Temperature Sensor (3)	Manual	b F1	Running External Interlock (3)	Manual
b AF	Bearing Sensor #1 (Inboard) (3)	Manual	b F2	Low Oil Pressure	Manual
b b0	Bearing Sensor #2 (Outboard) (3)	Manual	b F3	Low Oil Temperature	Auto
b d9	Extended Power Loss	Auto	b F4	High Oil Temperature	Manual
b dA	Surge	Manual	b F5	High Condenser Refrig. Pressure	Manual
b dC	Condenser Water Flow Overdue	Manual	b F7	Condenser Water Flow	Auto
b dE	Condenser Pressure Start Inhibit	Manual	b F8	Improper Unit Identification	Manual
b E2	Momentary Power Loss	Auto	b F9	Free-Cooling Valves	Manual
b E3	Phase Imbalance	Manual	b FA	Actuator	Manual
b E4	Phase Loss	Manual	b Fb	Low Evaporator Refrig. Temp.	Manual
b E5	Phase Reversal	Manual	b FF	Unit Control Module	Manual

Notes:

1. Check the "Manual Reset Required" status indicator light to determine if manual reset is necessary.
2. It is not possible to clear a latching diagnostic condition (i.e., one requiring manual system reset) at the unit from a higher-level device (e.g., an SCP699 or Trane BAS).
3. Optional feature.

Clear Restart Inhibit Push-button

By pressing this pushbutton switch (i.e., located to the right of the "Chilled Water Setpoint" potentiometer), the service technician can clear the restart inhibit timer.

CAUTION: The "Clear Restart Inhibit" button is for use only by a qualified service technician. Using this button more than once in 30 minutes may seriously damage the motor.

Control Response Setpoint

(To be set/calibrated by qualified Trane service technician only). Located to the left of the display window, this manually adjustable potentiometer can be set at any position between 1 and 237. (The units used to delimit these settings are arbitrary.)

The control response setting directly affects the vane controller's speed of response to changes in cooling requirements; the lower the control response setting, the slower the response time of the vane controller.

To view the actual control response setting, position the vane control switch at "Hold" and press the "Display Advance" push-button until code prefix " -" appears.

Start Differential Setpoint

(To be set by qualified Trane service technician only). With an adjustment range of 2-10 F (1- 6 C), this manually adjustable potentiometer establishes the number of degrees that the leaving chilled water temperature must rise above setpoint before the unit will start. (It also determines the actual compressor "stop" point; see "Fuse 1F2 Branch Circuit" under Electrical Sequence of Operation for further explanation.)

To display the actual start differential in the display window, position the vane control switch at "Hold" and press the "Display Advance" push-button until code prefix " | " appears.

Condenser Limit Setpoint (% hpc; Option)

(To be set by qualified Trane service technician only). Optional condenser limit control provides a means for maintaining chiller operation while high head pressure conditions exist.

Notice that the condenser limit potentiometer can be set at any point from 80% to 120% of the rated high pressure control trip point. for standard units with an HPC cutout is 20 to 30 psig.

Once established, the UCP compares this value with condenser refrigerant (head) pressure. As the head pressure approaches the condenser limit setpoint, the UCP either slows/prohibits van opening, or initiates a regulated van closure.

Remember that the condenser high pressure cutout switch (1S1) remains active, and will shut down unit operation on latching diagnostic b_F5 (i.e., "high condenser refrigerant pressure") if its trip point is exceeded view the actual condenser limit setpoint on the UCP's display, adjust the vane control knob to "Hold" and press the "Display Advance" push-button until "-" code prefix appears.

Evaporator Refrigerant Trip Setpoint

(To be set by qualified Trane service technician only). With a standard adjustment range of 29 to 34 F (-2 C to 1C), this manually adjustable potentiometer is used to establish the chiller's low refrigerant temperature trip point. An optional "extended range" is also available which provides an adjustment range of 0 to 34 F (1 to 18 C.)

To view the actual control setting, adjust the vane control knob to "Hold" and press the "Display Advance" push-button until the "-" code prefix appears.

Note: Attempting to adjust the evaporator refrigerant trip point below the minimum range value results in a latching diagnostic. (Diagnostic code b_A3 will flash alternately on the display with the operating code at the time the minimum range value was violated.)

CAUTION: to assure proper chiller operation, adjustment of this control must always be service technician.

UCP "Summary Sheet"

A summary of UCP operating and diagnostic codes, display menus, timing functions, control cutout points and terminal strip connections along with an illustration of micro module 1U3 is provided of this manual.

Electrical Sequence Of Operation

Overview

This section will acquaint the operation with the control logic governing CVHE /CVHF chillers equipped with UCP695-based control systems. Be sure to refer to the typical wiring schematic shown in Figure 16 when reviewing these step-by-step electrical sequences of operation. Available starter electrical configurations are illustrated by Figure 17.

Note: The typical wiring diagrams in Figures 16 and 17 are representative of standard CVHE/ CVHF units and are provided only for general reference. They may not reflect the actual wiring of your unit. For specific electrical schematic and connection information, always refer to the wiring diagrams that shipped with the chiller.

With the supply power disconnect switch or circuit breaker (2CB1) closed, 120-volt control power is provided through control power transformer 2T4 and a 30-amp starter panel fuse (2F4) to terminal 1TB5-1 in the UCP control panel. From this point, control voltage flows to:

Fuse 1F2, supplying power to micro module 1U3 and the starter control, oil heater, and power supply transformer (1T1) circuits.

Fuse 1F3, supplying power to the oil pump and inlet vane actuator circuits; and,

Fuse 1F4, supplying power to the purge control system. Although these 3 branch circuits energize simultaneously, the functions occurring in each circuit are described separately in the following paragraphs.

Fuse 1F2 Branch Circuit

120-Volt control power passing through fuse 1F2 travels to 5 separate subcircuits:

1. Low-voltage power is provided to micro module 1U3, relay output module 1U1 and power supply output module 1U2 through fuse 1F5 and power supply transformer 1T1.

2. Oil tank heater 4HR1 may be energized via the normally-open K6 contacts of power supply output module 1U2. (The status of these contacts open or closed is based on input from oil sump temperature sensor 4RT7.)

Note: UCP control logic is designed to energize the oil tank heater as required to maintain a sump temperature of 140° F to 145° F (60 C to 63 C) when the chiller is not running. Micro module 1U3 also monitors sensor 4R7 while the chiller is operating, and will shut down the unit on latching diagnostic b F4 if oil sump temperature reaches 180°F (83 C).

3. Condenser water flow interlock circuit.

4. Chilled water flow interlock circuit.

5. Starter control circuit.

Chilled and Condenser Water Flow Interlock Circuits

Control voltage passing through fuse 1F2 also energizes the chilled and condenser water flow interlock circuits. Closure of flow switches 5S2 and 5S3 along with the auxiliary contacts of water pump contactors 5K1 and 5K2 in the interlock circuits energizes the chilled and condenser water

pump relays (1K16, 1K17).

Notice that chilled water pump relay 1K16's normally-open, "proof-of-flow" contacts are connected between Terminals 1TB5-12 and 1TB5-13 in the high-voltage section of the UCP control panel. (See Line 41 in Figure 16.)

Closure of the normally-open set of 1K17 contacts (Figure 16, Line 89) is the UCP's "proof-of-flow" signal for the condenser water circuit. Notice that this set of contacts is located in a low voltage (< 80V) input circuit connected to Terminals 1TB3-22 and 1TB3-23 on micro module 1U3.

Micro Module and "Wye-Delta" Starter Control Circuits

While branch circuit fuse 1F2's micro module and "wye-delta"-type starter control subcircuits are separate, their functions are closely coordinated and are discussed together in the following paragraphs.

120-Volt control power enters power supply output module 1U2 at Terminal 1TB2-9. (See Line 16 of Figure 16.) Logic circuits within micro module 1U3 determine the "net" contact status (open or closed) of reset relay K1, stop relay K2 and overload relay K3 based on input signals sent to 1U3 and its timers.

Individual access to the K1, K2 and K3 relays is not possible; however, the "net state" of all 3 relays is available between Terminals 8 and 9 on terminal block 1TB2. When the "net state" of the K1, K2 and K3 contacts along with condenser high pressure switch 1S1 is closed,

WARNING
DISCONNECT ELECTRIC POWER SUPPLY BEFORE SERVICING TO PREVENT INJURY OR DEATH DUE TO ELECTRICAL SHOCK.

AVERTISSEMENT
DÉBRANCHER DU CIRCUIT D'ALIMENTATION ÉLECTRIQUE AVANT L'ENTRETIEN POUR ÉVITER BLESSURE OU MORT PAR ÉLECTROCUTION.

CAUTION
USE COPPER CONDUCTORS ONLY TO PREVENT EQUIPMENT DAMAGE. UNIT TERMINALS ARE NOT DESIGNED TO ACCEPT ANY OTHER WIRING.

ATTENTION
UTILISER SEULEMENT DES CONDUCTEURS EN CUIVRE POUR ÉVITER D'ENDOMMAGER L'ÉQUIPEMENT. LES BORNES NE SONT PAS PRÉVUES POUR AUTRES TYPES DE FILS CONDUCTEURS.

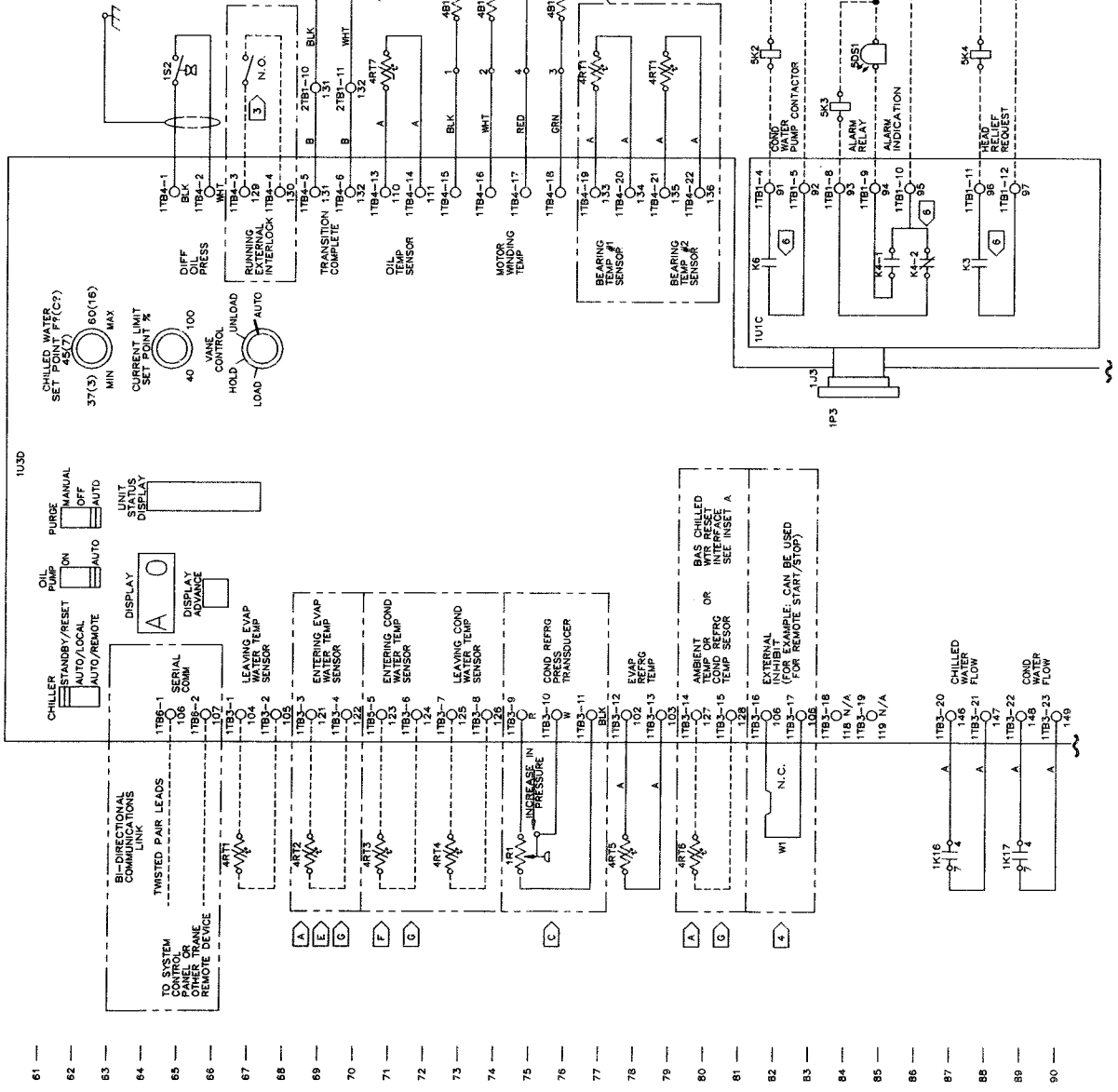

- NOTES:**
1. DASHED LINES INDICATE FIELD WIRING BY OTHERS. PHANTOM LINES INDICATE FIELD WIRING BY THE MANUFACTURER. WIRING BY OTHERS MAY BE OF DIFFERENT VOLTAGE OR CURRENT RATING. A WIRING DIAGRAM IS REQUIRED FOR SERVICING OPTIONS.
 2. ALL FIELD WIRING MUST BE IN ACCORDANCE WITH LOCAL, STATE AND LOCAL REQUIREMENTS. OTHER LOCAL AND STATE REQUIREMENTS MAY APPLY. COAXIAL CABLES ARE AVAILABLE FOR FIELD WIRING. TO 1TB3-1, 1TB3-2 & 1TB3-3 IS LOW VOLTAGE (30 VOLTS MAX) ONLY.
 3. MANUAL RESET IS ACCOMPLISHED BY MOVING THE CHILLER SWITCH, LINE 61, FROM SET TO RUN. IT IS ALSO REQUIRED FOR A TRIP-OUT DUE TO THE RUNNING EXTERNAL INTERLOCK, LINE 67.
 4. AUXILIARY TERMINAL CONNECTIONS FOR A CUSTOMER SPECIFIED OR INSTALLED OPERATING STATUS INPUT, TERMINALS 1TB3-16 EXTERNAL INPUT IS NOT USED.
 5. THE FOLLOWING CAPABILITIES ARE OPTIONAL AND THEY ARE IMPLEMENTED AND WIRED AS REQUIRED FOR A SPECIFIC SYSTEM APPLICATION.
 - A CHILLED WATER RESET—REQUIRES WIRING TO 481R2, LINES 67 & 68.
 - B AMBIENT TEMP BASED CHILLED WATER RESET—REQUIRES WIRING TO 481R1, LINES 67 & 68.
 - C FILLED LEAVING EVAP WATER TEMP SENSOR (481R1 LINE 67) FOR 481R6 LINE 80 AS AN AMBIENT TEMP SENSOR.
 - D CONDENSER LIMIT CONTROL—FACTORY WIRED AND MOUNTED IN CONTROL PANEL.
 - E BEARING TEMPERATURE SENSORS—481R2, 481R3, 481R4, 481R5, 481R6, 481R7 & 481R8.
 - F ENTERING EVAP TEMP SENSOR—REQUIRES MATCHED PAIR OF THERMISTORS 481R2, LINES 67 & 68.
 - G WATER TEMP SENSORS MATCHED PAIR LINES 71 & 73.
 - H TRASSER MONITORING PACKAGE INCLUDES OPTIONS TO LEAVE AND FLOW THERMISTOR FOR 481R6 LINE 80 TO BE USED AS CONDENSER REFRIGERANT TEMP SENSOR.
 - I REMOTE GENERIC BAS CHILLED WTR RESET—REQUIRES WIRING TO 481R10 OR FIELD INSTALLED. CAN NOT BE USED WITH OPTION G.
 - J RELAY COILS NOT SHOWN. CONTACTS ARE CONTROLLED BY THE LOGIC OF THE MICRO-PROCESSOR. SEE SEQUENCE OF OPERATION LINES 302.
 - K NEGATIVE SIGNAL COMPONENTS ARE GROUND TO TOP OF EQUIPMENT. SIGNALS SHALL BE ISOLATED OR EQUIPMENT SHALL BE ISOLATED FROM ELECTRICAL SERVICE GROUND AND ISOLATED FROM ELECTRICAL SERVICE. SPECIAL CONSIDERATION MUST BE GIVEN TO OTHERS. CURRENT LIMIT ON THE CURRENT SOURCE REGULATES CURRENT LIMIT ON THE CURRENT SOURCE. USE A SEPARATE POWER SUPPLY FOR EACH CHANNEL. INSTALL A LOOP ISOLATOR IN EACH CHANNEL TO PREVENT LOOP INTERFERENCE.

Figure 17
Available Starter Configurations

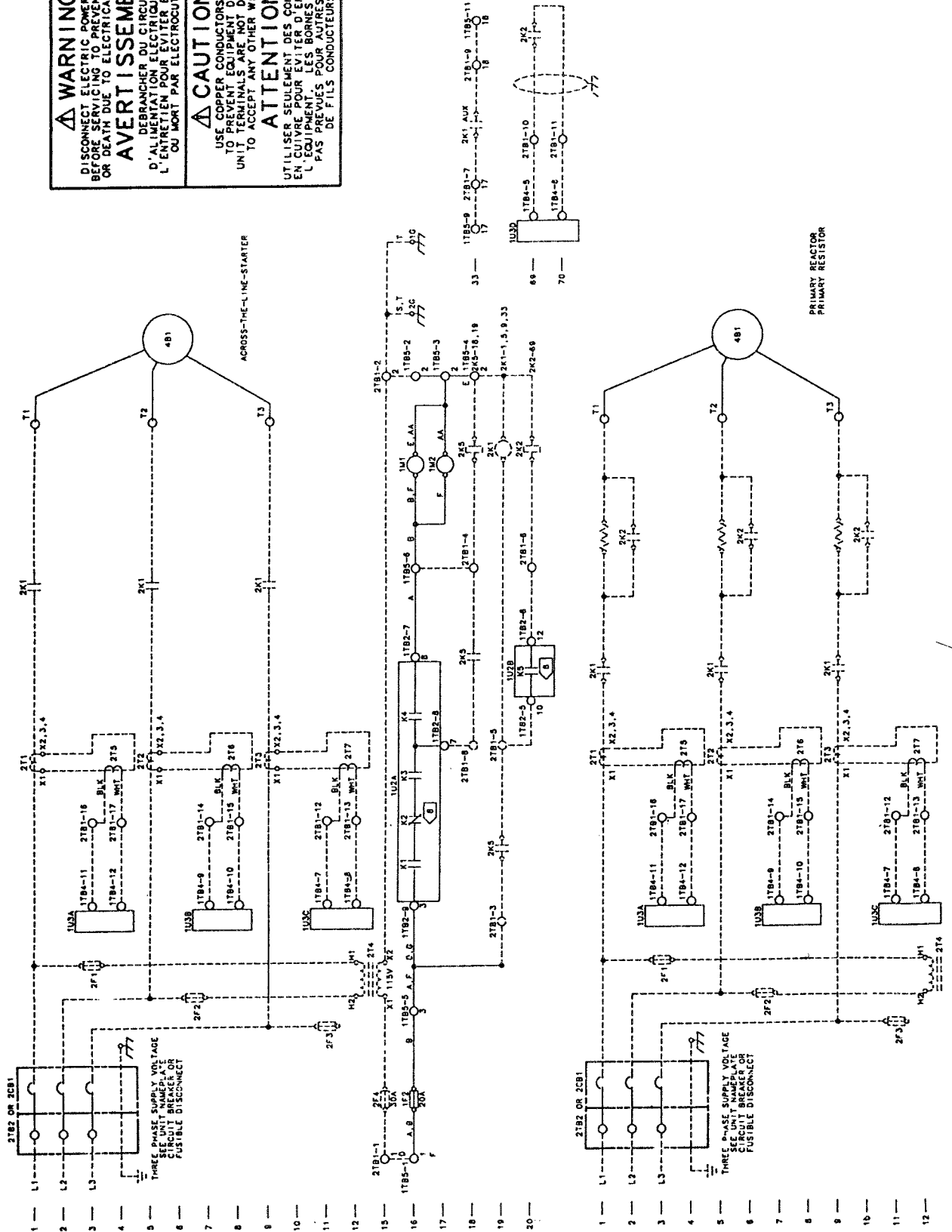

⚠ WARNING
 DISCONNECT ELECTRIC POWER SUPPLY BEFORE SERVICING TO PREVENT INJURY OR DEATH DUE TO ELECTRICAL SHOCK.
AVERTISSEMENT
 DEBRANCHER DU CIRCUIT D'ALIMENTATION ELECTRIQUE AVANT L'ENTRETIEN POUR EVITER BLESSURE OU MORT PAR ELECTROCUTION.

⚠ CAUTION
 USE COPPER CONDUCTORS ONLY TO PREVENT EQUIPMENT DAMAGE. UNIT TERMINALS ARE NOT DESIGNED TO ACCEPT ANY OTHER WIRING.
ATTENTION
 UTILISER SEULEMENT DES CONDUCTEURS EN CUIVRE POUR EVITER D'ENDOMMAGER L'EQUIPEMENT. LES BORNES NE SONT PAS PREVUES POUR AUTRES TYPES DE FILS CONDUCTEURS.

Figure 17
(Concluded)

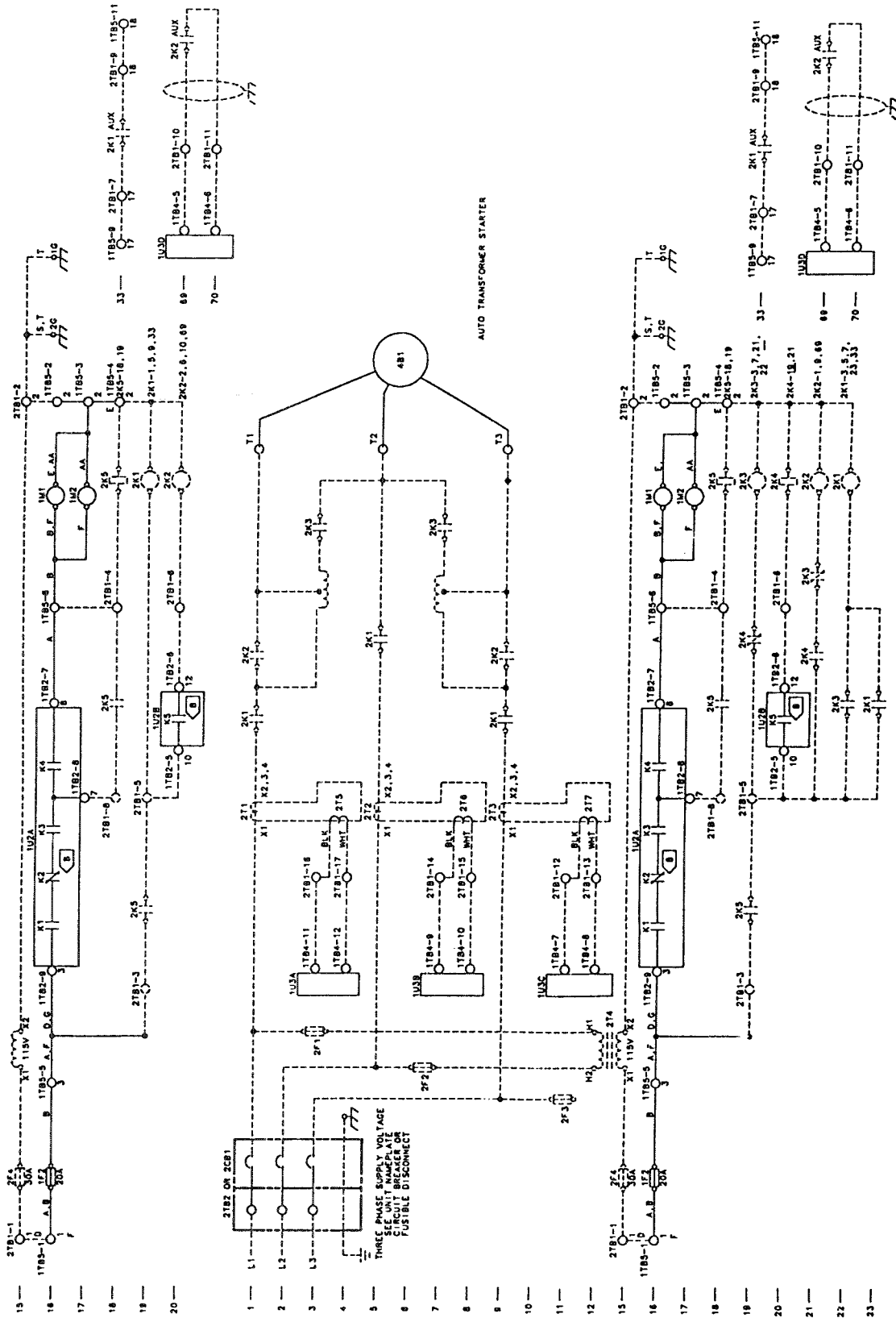

If cooling is required and all of the conditions required for start-up are met, micro module 1U3 sends a signal to power supply output module 1U2 to close the K4 contacts. This allows control voltage to flow to hour meter 1M1 and start counter 1M2; at the same time, a "start" signal is sent to pilot relay 2K5.

Notice that pilot relay 2K5 has 2 sets of normally-open contacts. The first set (Line 18; Figure 16) closes to lock the pilot relay into the control circuit around the K4 contacts.

Closure of the second set of 2K5 contacts (Line 19) allows control voltage to flow through the normally-closed auxiliary contacts of run contactor 2K2 (2M) and transition contactor 2K4 (1A) to the coil of shorting contactor 2K3 (S).

When shorting contactor 2K3 energizes, its normally-open, auxiliary contacts (Line 21) close; this allows control voltage to flow to the coil of start contactor 2K1.

With 2K1 now energized, its normally-open, auxiliary contacts (Line 22) close; this locks start contactor 2K1 into the control circuit around the auxiliary 2K3 contacts in Line 21 (Figure 16). Power is now supplied to the "wye" ("star") windings of compressor motor 4B1 through start contactors 2K1 and 2K3,

As the compressor accelerates, motor current draw decreases. When current draw drops to 85% of RLA, micro module 1U3 sends a signal to power supply output module 1U2 to close the normally-open contacts of compressor transition relay K5.

This energizes the coil of transition contactor 2K4 and causes its normally-closed set of auxiliary contacts (Line 19) to open.

With the circuit to shorting contactor 2K3 now open, 2K3 de-energizes and its normally-closed, auxiliary contacts

(Line 22) reclose to allow control power to reach the coil of run contactor 2K2. Once the auxiliary set of normally-open 2K2 contacts in Line 23 closes, run contactor 2K2 is locked into the control circuit around the auxiliary, normally- open 2K3 and 2K1 contacts (Lines 21 and 22).

A normally-closed set of auxiliary 2K2 contacts also opens in Line 19 to interrupt control voltage to transition contactor 2K4.

Now that the "delta" motor windings are energized, compressor 4B1 is operating in its normal "run" mode; it will continue to do so until the "net state" of the k1, K2 and K3 contacts (Line 16) is open. Once this "open" condition occurs, voltage to pilot relay 2K5 is lost and its contacts reopen.

Any of the following events will result in a "net state" of "open" for contacts K1, K2 and K3, and stop compressor operation:

1. Adjusting the chiller switch to "Standby/Reset";
2. UCP detection of a latching or non-latching diagnostic condition; or,
3. Satisfaction of the cooling requirement (i.e., building load drops to the point where machine operation is no longer practical).

Determination of an actual compressor "stop" point based on satisfaction of cooling demand hinges on the start differential setpoint. the relationship between this setpoint and the UCP's "shutdown" criteria is illustrated in Table 5.

Table 5
CVHE/CVHF
Compressor "Stop" Points

Chiller Delta-T ° F	Rec. Start Differential Setpoint ° F	Chiller Shutdown Point (Degree below Setpoint) ° F
4 or less	2.0	2.0
5 or 6	3.0	2.0
7 or 8	4.0	2.0
9 or 10	5.0	2.0
11 or 12	6.0	2.0
13 or 14	7.0	2.0
15 or 16	8.0	2.0
17 or 18	9.0	2.0
19 or more	10.0	2.0

Note: "Chiller shutdown point" refers to actual leaving chilled water temperature with respect to the chilled water setpoint (CWS).

Fuse 1F3 Branch Circuit Oil Pump Circuit

120-Volt control power from control power transformer 2T4 flows through branch circuit fuse 1F3 and Terminal 1TB5-10 to a 6.2 amp fuse (1F1). Fuse 1F1 protects the oil pump motor (4B3) from overamperage conditions.

Current passing through fuse 1F1 reaches 2 normally-open, parallel sets of contacts those of oil pump relay K7 and start contactor 2K1. K7's are located on power supply output module 1U2, but contact status open or closed is governed by micro module 1U3.

Note: While the K7 contacts are automatically closed by 1U3 as a part of the start sequence, they can also be closed manually by adjusting the oil pump switch from "Auto" to "On".

With the K7 contacts closed, vent-line interval timer 1DL2 energizes and closes its set of normally-open contacts for 90 seconds. During this period, closure of vent-line solenoid valve 4L1 isolates the oil sump from the compressor to prevent loss of oil pressure. When the 90-second interval expires, 1DL2's contacts reopen and solenoid valve 4L1 de-energizes to reopen the oil sump vent line.

Closure of the K7 contacts also allows current to pass through the coil of oil pump starter relay 1K8 to the "run" windings of oil pump motor 4B3.

When motor 4B3 first starts, current draw is high; this causes current-sensing relay 1K8 to close its normally-open contacts (Line 31; Figure 16) and "pull in" of pump capacitor 1C1. With this circuit complete, current now flows to the

"start" windings of the oil pump motor.

As the pump motor accelerates, its amp draw eventually falls below the "capacitor-enable" threshold of relay 1K8. Once this occurs, 1K8 reopens its normally-open contacts, and power is supplied only to the "run" windings of motor 4B3.

The normally-open, auxiliary 2K1 contacts (Line 33) that parallel those of oil pump relay K7 (Line 32) are located on start contactor 2K1. As soon as 2K1 energizes, these auxiliary contacts close. Notice that completion of this circuit assures that voltage is provided to the oil pump motor as long as the compressor motor is operating.

Oil pump operation ceases when both the K7 (Line 32 and auxiliary 2K1 (Line 33) contacts open.

Vane Actuator Circuit

Control power passing through branch circuit fuse 1F3 and Terminal 1TB5-10 not only energizes the oil pump circuit, but also provides power to the inlet vane actuator circuit. See Figure 16, notice that current enters van actuator motor 4B2 at Terminal 2. (Inset D of this schematic indicates typical, internal actuator wiring.)

Voltage entering the actuator at Terminal 2 passes through a thermal overload protection device to the "open" and "close" sets of actuator motor windings. A capacitor is connected to the opposite ends of these windings to provide the capacitance needed to start and run the vane actuator motor.

Current flowing from the "open" motor winding passes through an end switch and out of the actuator

at Terminal M2, while current flowing through the "close" motor winding passes through another end switch and out of the actuator at Terminal M1.

CAUTION: To prevent actuator damage resulting from overheated motor windings, actuator motor end switches must be adjusted to open the motor circuits before the actuator drive arm reaches the end of its travel.

Control of the inlet vane actuator is achieved via 2 Triac switches (Q7, vanes open; Q8, vanes closed) located in relay output module 1U1. Functionally, Q7 and Q8 each operate like a simple set of contacts.

While the operation of both Triacs is automatically governed by micro module 1U3, manual control is possible by positioning the vane control switch at "Load", "Hold" or "Unload".

Note: Manual loading or holding does not take precedence over the current limit (A 75), condenser limit (A 76) or evaporator limit (A 77) modes of operation.

Purge System

Because some sections of the chiller's-refrigeration system operate at less-than-atmospheric pressure, the possibility exists that air and moisture may leak into the system. If allowed to accumulate, these non-condensibles become trapped in the condenser; this increases condensing pressure and compressor power requirements, and reduces the chiller's efficiency and cooling capacity.

The Trane Purifier Purge is the only purge system available for the CVHE/CVHF chiller. The purge is designed to remove non-condensable gasses and water from the refrigeration system. Purifier Purge unit operation, maintenance and troubleshooting is covered by a separate operation and maintenance manual (PRG-OM-4).

Control Options

Note: The typical wiring diagrams show in Figures 18 and 19 are provided only as a general reference. They may reflect the actual wiring of your unit. For specific electrical schematic and connection information, always refer to the wiring diagrams that shipped with the chiller.

Free Cooling

As described in Mechanical Operation, this control option adapts the basic chiller to function as a simple heat exchanger without controlling leaving water temperature.

Free cooling must be initiated manually by adjusting the free cooling switch (Figure 13) to the "On" position. When this is done (and the compressor is running), the UCP issues a "stop" signal and the chiller enters post-lube (operating code A79).

Note: As soon as post-lube is initiated, the compressor motor and condenser water pump starters de-energize; oil pump operation continues until the 2-minute post-lube cycle expires.

Once post-lube is complete, operating code A1 appears on the display and micro module 1U3 sends a "close" signal to inlet guide vane actuator 4B2. (Latching diagnostic bFA occurs if vane closure is not established within 3 minutes.)

If the vanes close within 3 minutes, a "start" signal is sent to the condenser water pump; condenser flow switch 5S3 must then close within 3 minutes, or the UCP will shut down chiller operation on latching diagnostic b dC.

See Figure 18 for typical schematics of the free cooling electrical circuits. When the inlet guide vanes are closed and condenser water flow is established, the UCP energizes 4 sets of K1 free cooling relay contacts (Lines 36 through 39) and a set of K2 free cooling relay contacts (Line 90) in relay output module 1U1.

Note: The normally-open K2 contacts (Line 90) provide the owner with the electrical access needed to control auxiliary equipment during the free cooling cycle (e.g., water flow through the cooling tower during the free cooling mode). Actual use of the K2 contacts may vary with any given chiller application.

Two sets of normally closed K1 contacts (Lines 36 and 38) now open while the 2 normally open sets of K1 contacts (Lines 37 and 39) close. This completes the "open" circuits of the free cooling liquid (4B12) and gas (4B23) -line valve actuators. Remember that both valves must open within 3 minutes, or unit operation is locked out on latching diagnostic b F9.

Operating A9 (free cooling) appears on the display when the UCP verifies that the free cooling valves are open.

Note: UCP control logic prevents the compressor from starting when the chiller is operating in the free cooling mode. Manual control of the inlet guide vanes (via the vane control switch) is also disabled at this time.

Once the chiller functioning in the free cooling mode, powered e cooling switch is adjusted to "Off" and the UCP verifies that the free cooling valves are closed.

Hot Gas Bypass

The hot gas bypass (HGBP) control option is designed to minimize machine cycling by allowing the chiller to operate stably under minimum load conditions. In these situations, the inlet guide vanes are "locked" at a preset minimum position, and unit capacity is governed by the HGBP valve actuator.

Control circuitry (see Figure 19) is designed to allow both the inlet guide vanes and the HGBP valve to close for unit shutdown.

Four control components are associated with the hot gas bypass option:

HGBP Relay 1K15. Located in the UCP695 panel (Figure 13), this relay enables the HGBP valve and inlet guide vanes to close at unit shutdown.

HGBP Transfer Switch 4S4. This single-pole/double-throw (SPDT) limit switch is mounted on the actuator shaft (near the first-stage inlet guide vane linkage), and operates when the vanes pass through a particular minimum setting. It is field adjustable for optimum performance.

HGBP Valve Switch 4B5. Mounted on the hot gas bypass valve actuator, this SPDT limit switch operates when the valve just begins to open. Notice that the "close" limit switch mounted on the HGBP valve actuator (4B5) must be set to operate just after damper end switch 4S4 operates.

Discharge Temperature Switch 4S5. This device is designed to shut down the unit on latching diagnostic b F1 if the discharge temperature exceeds 210 F; (99 C) this prevents the chiller from running at extremely low loads for extended periods of time.

As soon as the power supply disconnect switch or circuit breaker 2CB1 is closed, 120-volt control power is supplied to the HGBP circuit through branch circuit fuse 1F3. Notice that this circuit includes both vane actuator motor 4B2 and HGBP valve 4B5.

Before the compressor "start" signal is sent, micro module 1U3 issues a "vane close" signal by closing Triac switch 1U1Q8. This, in turn, causes both the inlet vane (4B2) and HGBP valve (4B5) actuators to drive closed via the normally closed contacts of HGBP relay 1K15.

Once the inlet guide vanes are closed and the remainder of the start sequence is complete, the auxiliary contacts of start contactor 2K1 (Line 32) close and HGBP relay 1K15 energizes.

Machine start-up is usually followed by a series of "vanes open" signals issued by the UCP through successive closures of Triac switch 1U1Q7. (See "Fuse 1F3 Branch Circuit" in Electrical Sequence of Operation for an explanation of vane actuator operation.) Notice that the "vanes open" signal passes through HGBP valve motor end switch 4B45 (Line 36); this end switch remains closed as long as the HGBP valve is closed.

Continued loading eventually causes Transfer Switch 4S4 to change position so that it closes between vane actuator 4B2's M1 Terminal (Line 34) and Terminal 1TB7-3 (Line 37). Vane actuator 4B2 is now connected "directly" to Triac switches 1U1Q7 and 1UQ8 through 4S4; therefore, any additional loading or unloading dictated by the UCP is performed by 4B2 acting independently of HGBP valve actuator 4B5.

As the unit unloads and the inlet guide vanes again reach the preset minimum position, transfer switch 4S4 closes between Terminal 2 on 4B5 and Terminal 1TB7-3. This completes the HGBP valve actuator's "open" circuit so that any unload signals from the UCP will now drive the HGBP valve open. As soon as this occurs and the HGBP valve opens 4B5's end switch (Line 36) reverses its position and completes the "close" circuit of the HGBP valve actuator.

See Figure 18. Any load signals generated by the UCP must now pass through the "close" circuit of valve actuator 4B5 (Terminals 1-to-3) and through 4B5's end switch (Line 36 to "vanes open" switch 1U1Q7. In this manner, unit capacity is controlled by the HGBP valve actuator, with the inlet guide vanes held at their minimum position.

Once the UCP determines that additional cooling capacity is required, it issues a load signal that causes valve actuator 4B5 to drive the HGBP valve closed.

When the valve reaches the full-closed position, 4B5's end switch (Line 36) returns to its original position and inlet guide vane control is restored to valve actuator 4B2.

If the inlet guide vanes do not open past the minimum position (at start-up) before an unload signal is sent, the unit will use the HGBP valve actuator to control vane movement.

Note: Contact a qualified service technician for proper adjustment of the end switches on HGBP valve actuator 4B5 and HGBP transfer switch 4S4.

Relay Package

On modules prior to 1991 this UCP control option consists of the addition of 2 relays built into relay output module 1U1; alarm relay K4 and "head-relief request" relay K3. After February 1991 all 1U1 modules have the additional relays and are not an option.

Alarm Relay 1U1K4 activates whenever the UCP detects a latching diagnostic condition (i.e., one that requires manual reset), and provides the electrical access needed for field-installation of a customer-supplied alarm.

See Lines 84 through 87 in Figure 16. Notice that the customer-provided alarm relay (5K3) can either be field-connected between Terminals 1TB1-9 and 1TB1-10 for normally open contacts, or between Terminals 1TB1-8 and 1TB1-10 for normally closed contacts.

"Head-relief" request relay 1U1K3 is designed to be used in conjunction with the UCP's standard surge protection feature, as well as with the condenser limit control option. Its normally open relay contacts (Figure 16, Line 88) are field-accessible at Terminals 1TB1-11 and -12, and can be used to control or signal for a reduction in entering condenser water temperature.

Designed to prevent high refrigerant pressure trip-outs during critical periods of chiller operation, this UCP option consists of: (1) the manually adjustable condenser limit potentiometer on micro module 1U3; (2) pressure transducer 1R1; and (3) the associated inter-connecting piping and wiring.

The UCP monitors the condenser pressure registered by pressure transducer 1R1, and then compress this value to the manually adjusted setting of the condenser limit potentiometer.

Based on these inputs, the UCP modulates inlet guide vane position accordingly to keep the chiller on-line as long as possible (as the high pressure safety limit is approached).

Note: If the optional relay package option is installed, the head relief request relay may also energize to signal further corrective action (e.g., lowering entering condenser water temperature).

Keep in mind that the UCP's condenser limit control option supplements the protection already provided by condenser high pressure cutout switch 1S1.

Bearing Temperature Sensors (4RT8, 4RT9)

When this UCP control option is specified, temperature sensors 4RT8 and 4RT9 are factory-installed in the oil return lines of the inboard and outboard compressor motor bearings.

If the temperature registered by either of these sensors reaches or exceeds 180 F (83 C), the UCP shuts down chiller operation on latching diagnostic B EA (high bearing temperature at "Sensor # 1"), or b EA (high bearing temperature at "Sensor # 1"), or b EB (high bearing temperature at "Sensor # 2").

Note: 4RT8 is designated as "Sensor # 1." Its sensing element is installed in a well in the inboard bearing oil return line, and the leads are connected to Terminals 1TB4-19 and -20 on micro module 1U3. Designated as "Sensor # 2," 4RT9's sensing element is installed in a well in the oil return line of the outboard bearing; the sensor leads are connected to Terminals 1TB4-21 and -22. (Alternatively, these sensors may be epoxied to the underside of the oil return lines.)

Sensor Options

Along with the factory-installed bearing temperature sensors just described, the following Sensors are available to add at any time.

Entering Evaporator Water (4RT2). Sensor 4RT2 is installed in the water piping entering the evaporator, and is connected between Terminals 1TB3-3 and 1TB3-4 on micro module 1U3.

Entering (4RT3) and Leaving (4RT4) Condenser Water. Sensor 4RT3 is connected between Terminals 1TB3-5 and -6, and registers the temperature of the water entering the condenser. Field-installed in the water piping leaving the condenser, sensor 4RT4 is connected to Terminals 1TB3-7 and -8.

Condenser Refrigerant (4RT6). Sensor 4RT6's sensing element is epoxied to the refrigerant line located between the condenser and condenser/economizer flange, and the sensor leads must be field-connected to Terminals 1TB3-14 and 1TB3-15 on micro module 1U3. Required if controlled by SCP. Read-out is only enabled at a Tracer.

Figure 18
(Continued from previous page)

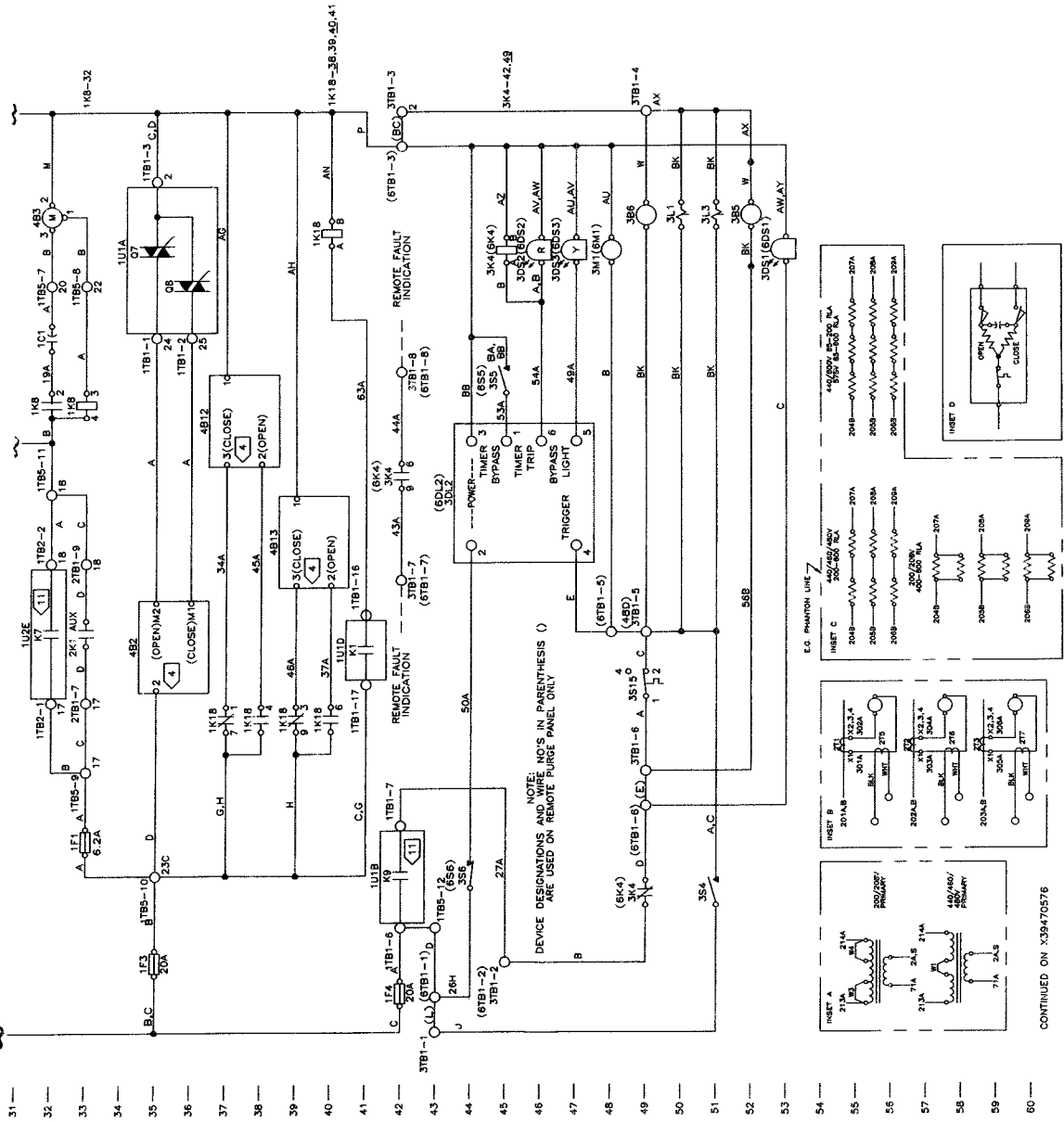

3515	TEMPERATURE SWITCH	49
3TB1	PURGE TERMINAL BLOCK (REMOTE PANEL TERM. BLOCK)	
4B1	COMPRESSOR MOTOR	5
4B1R2,3,4	MOTOR WINDING TEMP SENSOR	69,71,73
4B2	VALE ACTUATOR MOTOR	35
4B3	OIL PUMP MOTOR	32
4B12	LIQUID LINE VALVE	37
4B13	GAS LINE VALVE	39
4HR1	OIL TANK HEATER	27
4L1	VENT LINE SOLENOID	30
4RT1-9	THERMISTOR	69-80
50S1	ALARM INDICATION	85
5K1	COND WATER PUMP CONT. AUX	N/A
5K2	COND WATER PUMP CONT. AUX	82
5K3	ALARM RELAY	84
5K4	HEAD RELIEF REQUEST CONT.	88
5S2	COND WATER FLOW SWITCH	24
5S3	COND WATER FLOW SWITCH	25
5S4	INTERLOCK SWITCH	67

- NOTES:
- SOLID LINES INDICATE TRAPE WIRING, DASHED LINES INDICATE FIELD WIRING, PHANTOM LINES INDICATE OPTIONAL FEATURES OR ALTERNATE CIRCUITRY.
 - UNLESS OTHERWISE NOTED, ALL SWITCHES ARE SHOWN IN THE NORMAL POSITION AT THE TIME THE UNIT IS TURNED ON. RELATIVE HUMIDITY WITH ALL UTILITIES TURNED OFF AND AFTER A NORMAL SHUTDOWN HAS OCCURRED.
 - NUMBERS ALONG THE RIGHT SIDE OF THE SCHEMATIC DESIGNATE THE LOCATION OF THE CONTACTS BY LINE NUMBER. CONTACTS ARE SHOWN AS OPEN ABOVE THE LINE NUMBER POINTING UPWARD INDICATES A TIMED CONTACT WHICH BEARS WIRING WHEN ENERGIZED.
 - SEE INSET A FOR OTHER VOLTAGES. 575/600 VOLT PRIMARY SHOWN.
 - SEE INSET B FOR OPTIONAL AMPMETERS.
 - SEE INSET C FOR OTHER VOLTAGES. RESISTORS SHOWN FOR 240/208V AND 200-240V RUA.
 - SEE SERVICE MANUAL FOR INDIVIDUAL SECONDARY VOLTAGES.
 - THREE PHASE POWER SUPPLY VOLTAGE SEE UNIT NAMEPLATE.
 - RELAY COILS NOT SHOWN. CONTACTS ARE CONTROLLED BY THE LOGIC OF THE MICRO-MODULE (11U3). SEE SEQUENCE OF OPERATION LINES 102 - 115 NEXT PAGE.

WARNING
DISCONNECT ELECTRIC POWER SUPPLY BEFORE SERVICING TO PREVENT INJURY OR DEATH DUE TO ELECTRICAL SHOCK.

AVERTISSEMENT
DÉBRANCHER DU CIRCUIT D'ALIMENTATION ÉLECTRIQUE AVANT L'ENTRETIEN POUR ÉVITER BLESSURE OU MORT PAR ÉLECTROCUTION.

CAUTION
USE COPPER CONDUCTORS ONLY TO PREVENT EQUIPMENT DAMAGE TO TERMINALS ARE NOT DESIGNED TO ACCEPT ANY OTHER WIRING.

ATTENTION
UTILISER SEULEMENT DES CONDUCTEURS EN CUivre POUR ÉVITER D'ENDOMMAGER LE QUÉBRIENNEMENT DES TERMINAUX. PAS PRÉVUS POUR AUTRES TIPIES DE FILS CONDUCTEURS.

**Figure 18
(Continued)**

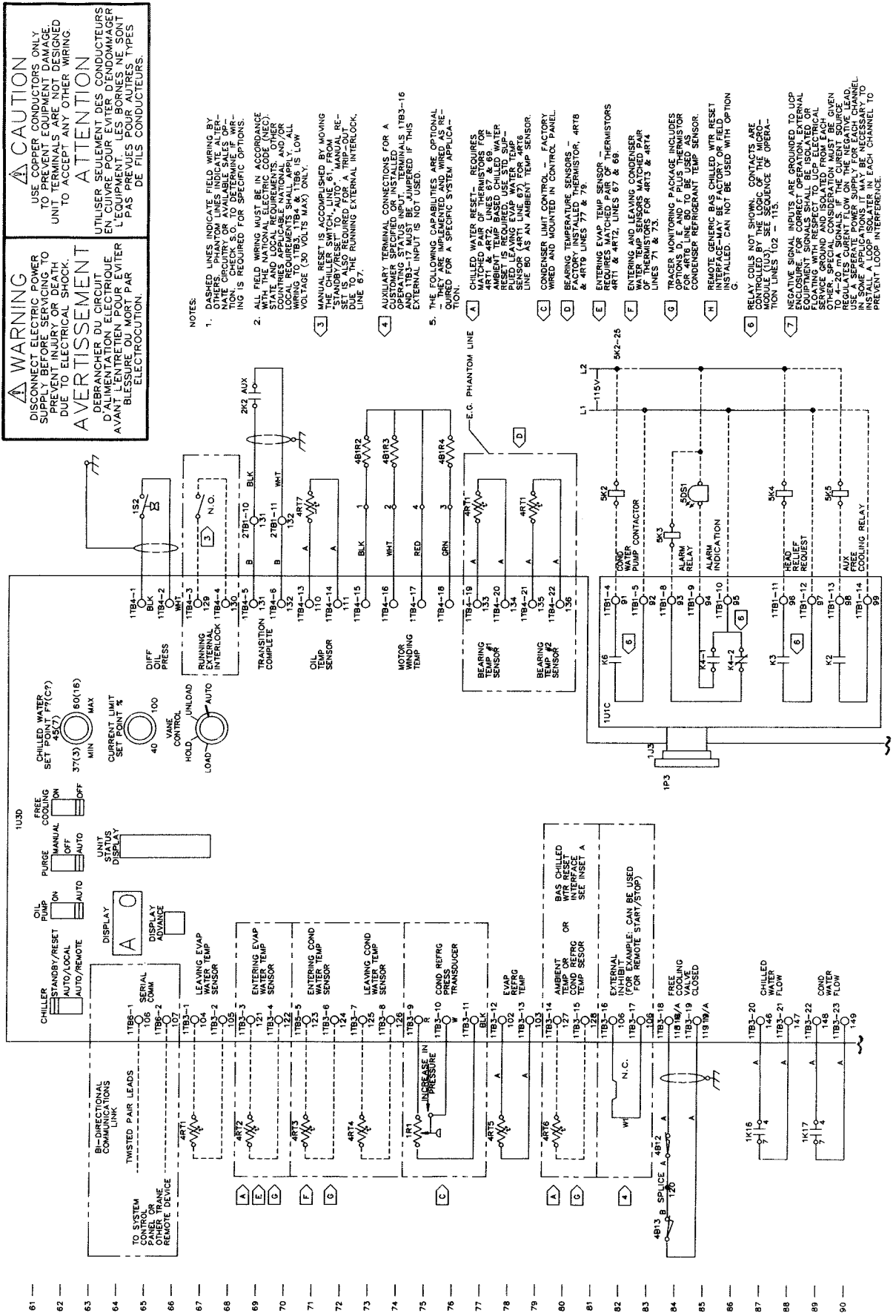

WARNING
DISCONNECT ELECTRIC POWER SUPPLY BEFORE SERVICING TO PREVENT INJURY OR DEATH DUE TO ELECTRICAL SHOCK.

AVERTISSEMENT
DEBRANCHER DU CIRCUIT D'ALIMENTATION ELECTRIQUE AVANT DE FAIRE DES REPARATIONS POUR EVITER LES BLESSURES DUE A L'ELECTROCUTION.

CAUTION
USE COPPER CONDUCTORS ONLY TO PREVENT EQUIPMENT DAMAGE. UNIT TERMINALS ARE NOT DESIGNED TO ACCEPT ANY OTHER WIRING.

ATTENTION
UTILISER SEULEMENT DES CONDUCTEURS EN CUIVRE POUR EVITER D'ENDOMMAGER LES TERMINAUX DE L'UNITE. LES POINTS DE MONTAGE NE SONT PAS PREVUS POUR ACCEPTER D'AUTRES TYPES DE FILS CONDUCTEURS.

- NOTES:**
- DASHED LINES INDICATE FIELD WIRING BY OTHERS. PHANTOM LINES INDICATE ALTERATIONS MADE TO THE ORIGINAL WIRING. CHECK S.O. TO DETERMINE IF WIRING IS REQUIRED FOR SPECIFIC OPTIONS.
 - ALL FIELD WIRING MUST BE IN ACCORDANCE WITH THE NATIONAL ELECTRIC CODE (NEC), LOCAL ELECTRICAL CODES, AND/OR LOCAL REQUIREMENTS SHALL APPLY. ALL VOLTAGE (30 VOLTS MAX) ONLY.
 - MANUAL RESET IS ACCOMPLISHED BY MOVING THE CHILLER SWITCH LINE FROM "STANDBY/RESET" TO "AUTO." MANUAL RESET IS REQUIRED IF THE RUNNING EXTERNAL INTERLOCK LINE 67.
 - AUXILIARY TERMINAL CONNECTIONS FOR A OPERATING SWITCHES OR INSTALLED THERMISTORS MUST BE WIRING TO "AUTO." MANUAL RESET AND 1TB3-17 MUST BE JUMPED IF THIS EXTERNAL INPUT IS NOT USED.
 - THE FOLLOWING CAPABILITIES ARE OPTIONAL AND ARE IMPLEMENTED AND WIRED AS REQUIRED FOR A SPECIFIC SYSTEM APPLICATION:
 - A CHILLED WATER RESET - REQUIRES MATCHED PAIR OF THERMISTORS FOR 4B1R2 AT 4RT2 LINES 67 & 69. IF RESET IS REQUIRED, USE 530 SUPP. SERVO LEAVING EVAP WATER TEMP SENSORS AS AN AMBIENT TEMP SENSOR.
 - C CONDENSER LIMIT CONTROL - FACTORY WIRED AND MOUNTED IN CONTROL PANEL BEARING TEMPERATURE SENSORS - 4RT8 & 4RT9 LINES 77 & 79.
 - E ENTERING EVAP TEMP SENSOR - REQUIRES MATCHED PAIR OF THERMISTORS 4RT1 & 4RT2, LINES 67 & 69.
 - F ENTERING AND LEAVING CONDENSER TEMPERATURE SENSORS - REQUIRES THERMISTORS FOR 4RT3 & 4RT4 LINES 71 & 73.
 - G TRACER MONITORING PACKAGE INCLUDES OPTIONS D, E, AND F PLUS THERMISTOR CONDENSER REFRIGERANT TEMP SENSOR LINES 71 & 73.
 - H REMOTE GENERIC BAS CHILLED WATER RESET INTERFACE - MAY BE FACTORY OR FIELD INSTALLED. CAN NOT BE USED WITH OPTION G.
 - I RELAY COILS NOT SHOWN. CONTACTS ARE MODULE (L1, L2). SEE SEQUENCE OF OPERATION LINES 102 - 115.
 - J NEGATIVE SIGNAL INPUTS ARE GROUNDED TO UPC ENCLOSURE. FOR CORRECT OPERATION, EXTERNAL FLOATING WITH RESPECT TO UPC ELECTRICAL SERVICE GROUND AND ISOLATED FROM EACH TO 4-20 mA SIGNALS OF THE CURRENT SOURCE REGULATES CURRENT FLOW ON THE NEGATIVE LEAD. IN SOME APPLICATIONS IT MAY BE NECESSARY TO INSTALL A LOOP ISOLATOR IN EACH CHANNEL TO PREVENT A LOOP INTERFERENCE.

Figure 18
(Concluded)

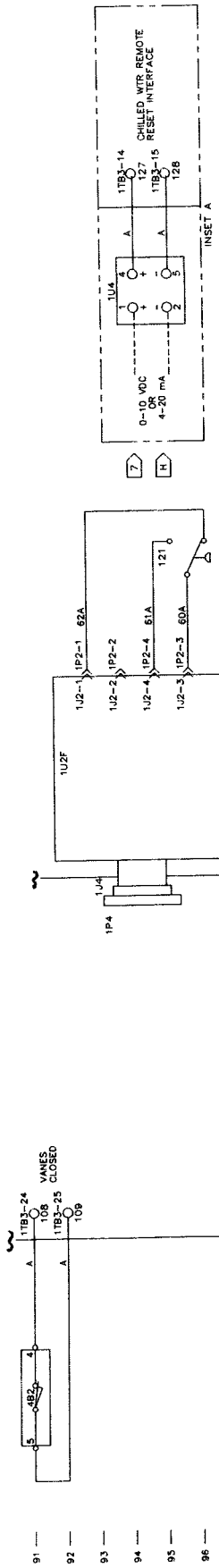

SEQUENCE OF OPERATION

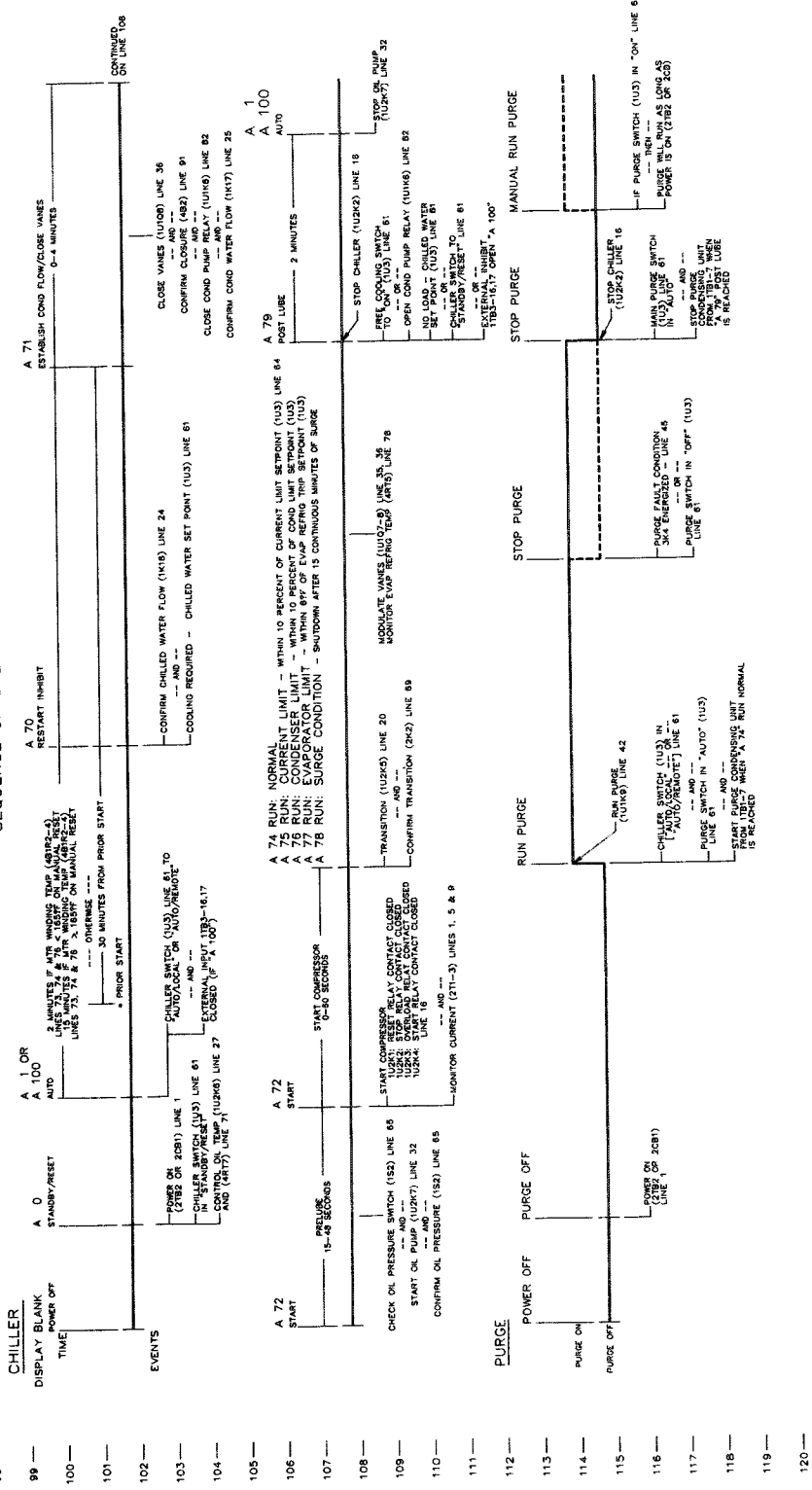

X39470576D

Figure 19
Typical Electrical Schematic
for 60 Hz CVHE/CVHF w/Hot Gas Bypass and
Unit-Mounted Starter

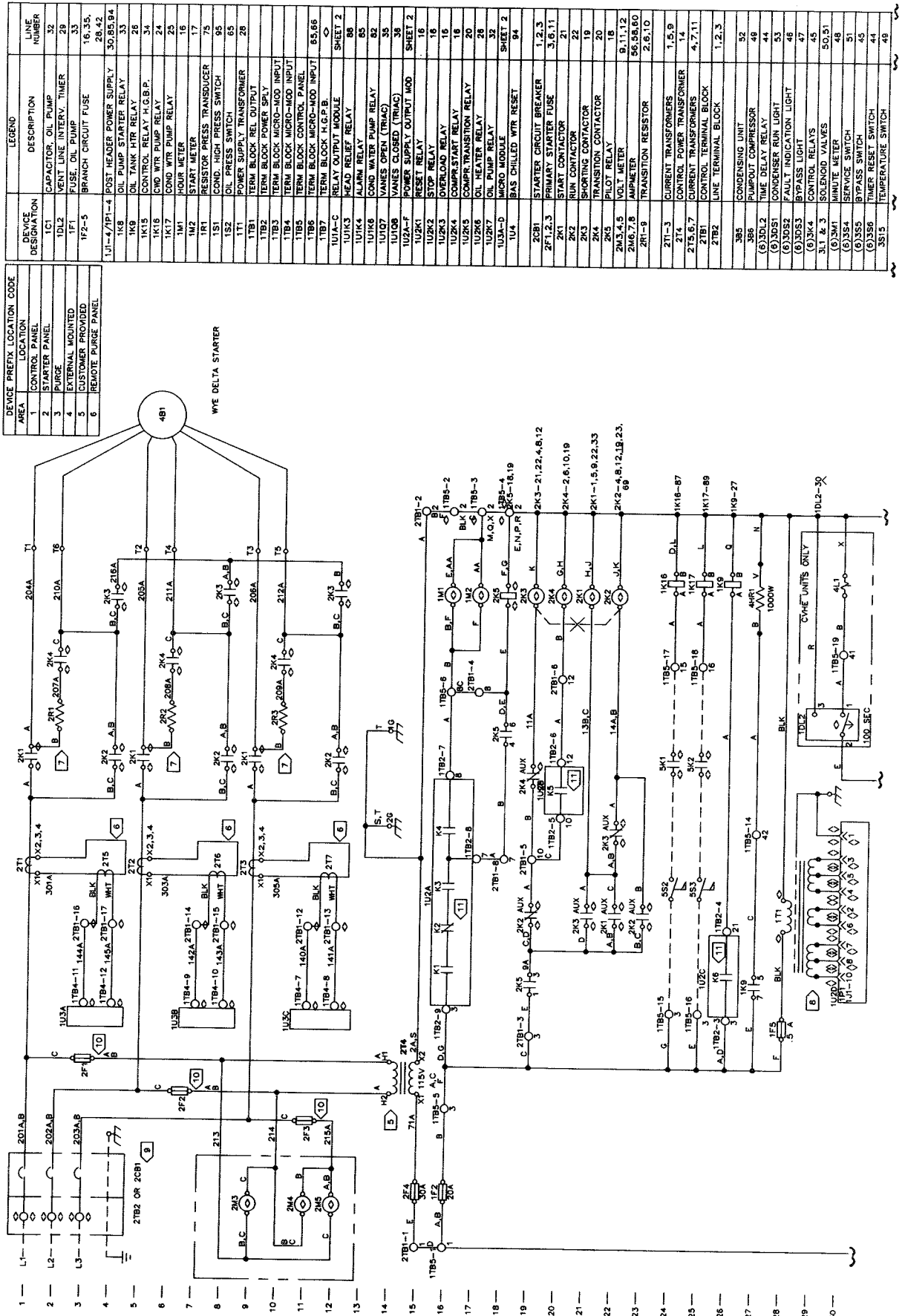

DEVICE PREFIX LOCATION CODE	
AREA	LOCATION
1	CONTROL PANEL
2	STARTER PANEL
3	PURGE
4	EXTERNAL MOUNTED
5	CUSTOMER PROVIDED
6	REMOTE PURGE PANEL

DEVICE DESIGNATION	DESCRIPTION	LEGEND	LINE NUMBER
1C1	CAPACITOR OIL PUMP		32
1D12	VENT LINE INTERV. TIMER		28
1F1	FUSE, OIL PUMP		33
1F2-5	BRANCH CIRCUIT FUSE		16, 35, 28, 42
1J-4/1P1-4	POST HEADER POWER SUPPLY		30, 95, 94
1K8	OIL PUMP STARTER RELAY		33
1K9	OIL TANK HTR RELAY		28
1K15	CONTROL RELAY H.G.B.P.		34
1K16	COND WTR PUMP RELAY		24
1K17	COND WTR PUMP RELAY		25
1M1	HOUR METER		16
1M2	START METER		17
1R1	RESISTOR PRESS TRANSDUCER		75
1S1	COND. HIGH PRESS SWITCH		95
1S2	OIL PRESS SWITCH		65
1T1	POWER SUPPLY TRANSFORMER		28
1TB1	TERM BLOCK REL. OUTPUT		
1TB2	TERM BLOCK POWER SP4		
1TB3	TERM BLOCK MICRO-MOD INPUT		
1TB4	TERM BLOCK MICRO-MOD INPUT		
1TB5	TERM BLOCK MICRO-MOD INPUT		
1TB6	TERM BLOCK MICRO-MOD INPUT		
1TB7	TERM BLOCK MICRO-MOD INPUT		65, 66
1U1A-C	RELAY OUTPUT MODULE		SHEET 2
1U1X-3	HEAD RELIEF RELAY		SHEET 2
1U1K4	ALARM RELAY		88
1U1K6	COND WATER PUMP RELAY		82
1U1O7	VANES OPEN (TRAC)		35
1U1O8	VANES CLOSED (TRAC)		38
1U2A-F	POWER SUPPLY OUTPUT MOD		SHEET 2
1U2K1	RESET RELAY		16
1U2K2	STOP RELAY		18
1U2K3	OVERLOAD RELAY		18
1U2K4	COMPR. START RELAY		20
1U2K5	COMPR. TRANSITION RELAY		20
1U2K6	OIL HEATER RELAY		28
1U2K7	OIL PUMP RELAY		32
1U3A-D	MICRO MODULE		SHEET 2
1U4	BAS CHILLED WTR RESET		84
2CB1	STARTER CIRCUIT BREAKER		1, 2, 3
2F1, 2, 3	PRIMARY STARTER FUSE		3, 6, 11
2K1	START CONTACTOR		21
2K2	RUN CONTACTOR		22
2K3	SHORTING CONTACTOR		19
2K4	TRANSITION CONTACTOR		18
2K5	PILOT RELAY		18
2M3, 4, 5	VOL. T. METER		9, 11, 12
2M6, 7, 8	AMP. METER		56, 58, 60
2R1-9	TRANSITION RESISTOR		2, 6, 10
2T1-3	CURRENT TRANSFORMERS		1, 5, 9
2T4	CONTROL POWER TRANSFORMER		14
2T5, 6, 7	CURRENT TRANSFORMERS		4, 7, 11
2T8	CONTROL TERMINAL BLOCK		
2T9	LINE TERMINAL BLOCK		1, 2, 3
3B5	CONDENSING UNIT		52
3B6	PUMP/OUT COMPRESSOR		46
3D12	TIME DELAY RELAY		44
3D51	CONDENSER RUN LIGHT		53
3D52	FAULT INDICATION LIGHT		48
3D53	FAULT INDICATION LIGHT		49
3K4	CONTROL RELAYS		45
3L1 & 3	SOLENOID VALVES		50, 51
3M1	MINUTE METER		86
3S4	SERVICE SWITCH		51
3S5	BYPASS SWITCH		43
3S6	TIMER RESET SWITCH		44
3S15	TEMPERATURE SWITCH		48

Figure 19
(Continued)

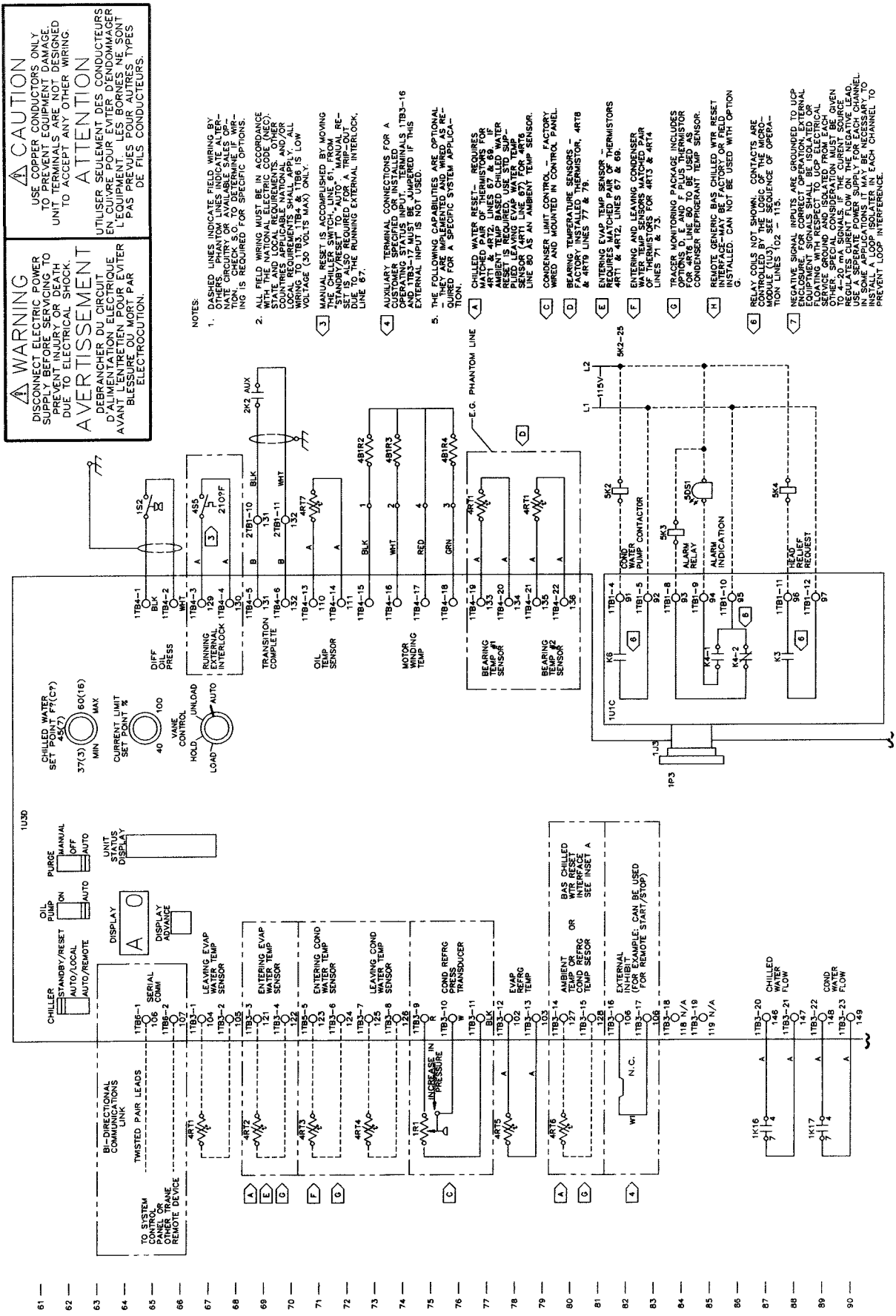

Serial Communication Interface (SCI)

This UCP control option allows micro module 1U3 to exchange information (e.g., operating parameters, setpoints and commands) with an SCP699 System Control Panel. Figure 20 illustrates how such a communication control network might appear. Notice that twisted-pair connectors are used to establish the communication link between the unit(s) and the SCP.

Additional information about this control option is provided in the installation manual and operator's guide that ships with the SCP699 System Control Panel.

Note: The SCI and chilled water reset (CWR) options are mutually exclusive; that is, a CVHE/CVHF unit cannot be equipped with both SCI and CWR.

Chilled Water Reset (CWR)

Chilled water reset is designed for those applications where the design chilled water temperature is not required at part load. In these cases, the leaving chilled water temperature setpoint can be reset upward using the chilled water reset option.

Optional chilled water reset (CWR) consists of a factory-installed module in the unit control panel and a field-installed temperature sensor. Sensor location is dependent on whether "load" or "ambient" chilled water setpoint reset is desired:

If "load" CWR is selected, the CWR sensor is field-installed in the return chilled water piping, and connected to Terminals 1TB3-3 and -4 of micro module 1U3.

With selection of "ambient" CWR, the sensor is connected to 1U3

terminals 1TB3-14 and -15, and is typically field-installed just inside the building's fresh air intake duct, or on the north exterior wall of the building. In either case, shelter the sensor from direct sunlight and the elements.

Operator selection of the type of chilled water reset desired for a given application is accomplished at the unit control panel. To access the chilled water reset controls, open the control panel door; the CWR reset type, action and reference knobs are located at the far left of micro module 1U3. See Figure 21.

WARNING: To prevent injury or death due to electrocution, use care when performing control set-ups, adjustments or other service-related operations with power on.

Notice that the conversion tables needed to determine CWR control settings (i.e., Tables A and B) are provided on the face of the micro module, at the immediate right of the current limit setpoint potentiometer. (Both tables are also shown in Figure 21) for your convenience.

Note: There are several important points to consider when using the UCP's optional chilled water reset (CWR) function:

a. To enable the CWR module, be sure to set the chiller switch at "Auto/Remote". (Notice that the "Remote Chilled Water Setpoint" status indicator light is illuminated when the CWR function is active.

b. Once the CWR module sends micro module 1U3 a new chilled water setpoint, it will not issue another setpoint change until the actual leaving chilled water temperature is within 1 F (-17 C) of

setpoint for 75 seconds.

c. As long as the chiller switch is set at "Auto/Remote", the CWR function remains active even while the unit is idle!

Load-Based CWR

1. **Reset Type Knob:** Set at "Evap. Delta-T".

2. **Reset Reference Knob:** Set at the design delta-T (DTFL) for the unit. Use Table B (Figure 20) to convert the unit DTFL to a letter code ("A" through "H").

Note: In those instances where the DTFL value falls between the values listed, always use the next lower value.

Example: Chiller A is designed to operate with an entering chilled water temperature (CWT) of 56 F (14 C), and a leaving chilled water temperature of 44 F (8 C).

a. Determine Chiller A's design Delta-T.

DTFL = Design Ent. CWT - Design Lvg. CWT
DTFL = 56 F - 44 F (14 C - 8 C)
DTFL = 12 F (-11 C)

b. **Convert Chiller A's DTFL to a letter code.** Locate 12 F (-11 C) DTFL in Table B under "Evap. Delta-T"; 12 F (-11 C) DTFL = "E".

c. **Adjust the reset reference knob to control setting "E".**

Figure 20
Serial Communication
Interface (SCI); Typical Network

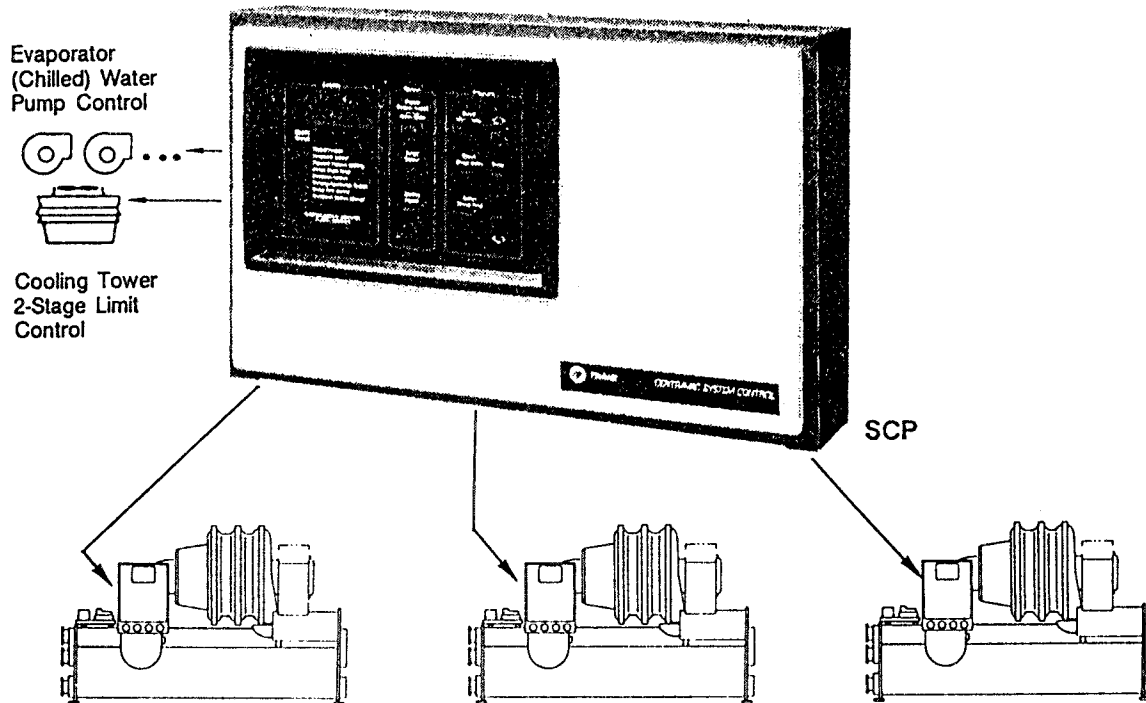

CVHE or CVHF
Chillers w/UCP695
Control Panels

Art No.
RF/CTV-1900
RF/CTV-1901

Figure 21
Micro Control Module (1U3)
w/Chilled Water Reset Option

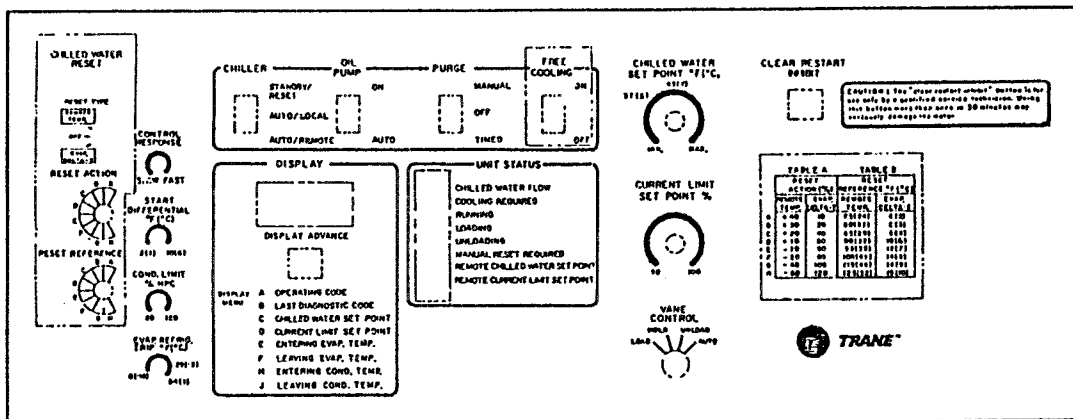

Table A

Table B

Reset Action (X)	Reset Reference F (C)	
	Remote Temp.	Evap. Delta-T
A	+ 40	10
B	+ 30	20
C	+ 20	40
D	+ 10	50
E	- 10	60
F	- 20	80
G	- 40	100
H	- 60	120

Notes:

1. Control option features (i.e., free cooling and chilled water reset) shown above are enclosed in phantom-line boxes.
2. Tables A and B on the above illustration are reproduced in larger type at left.

3. **Reset Action Knob:** Set at the amount of reset desired. Use the following equation and Table A (Figure 21) to determine the amount of reset desired; then convert this amount to a letter code (i.e., "A" thru "H").

$$RCWS = PCWS + RAS [DTFL - (ENT-LVG)]$$

Where:

RCWS = Reset Chilled Water Setpoint

PCWS = Front Panel Chilled Water Setpoint

RAS = Reset Action Setpoint

DTFL = Design Delta-T at Full Load

ENT = Entering Chilled Water Temperature

LVG = Leaving Chilled Water Temperature

Notes about this equation:

a. To convert the reset action values in Table A from percentages to decimal values, divide by 100. Decimal values must be used for the RAS variable in the equation.

b. System control will not allow chilled water reset downward even though it is possible in this equation.

c. Increasing the reset action setpoint (RAS) to a larger number results in more reset.

d. If you know how many degrees of chilled water reset are desired (i.e., (RCWS), as well as the DTFL, ENT and LVG, the equation can be rearranged to solve for the reset action setpoint (RAS):

$$RAS = RCWS - PCWS [DTFL - (ENT - LVG)]$$

Review Examples 1 and 2 below to ensure that you understand both: (a) how to calculate a load-based reset chilled water setpoint; and, (b) how this reset value changes with the selected reset reference and reset action control settings.

Example # 1:

$$DTFL = 10.0 \text{ F } (-12 \text{ C})$$

$$PCWS = 45.0 \text{ F } (8 \text{ C})$$

$$RAS = 0.5 \text{ (i.e., "50" in Table A)}$$

When the unit is operating at full load, ENT is 55F (13 C) and LVG is 45 F (8 C), so:

$$RCWS = 45 \text{ F } + 0.5 [10 \text{ F } - (55 \text{ F } - 45 \text{ F})]$$

$$RCWS = 45 \text{ F } + 0 \text{ F}$$

$$RCWS = 45 \text{ F } (8 \text{ C})$$

Since LVG and RWCS are equal (i.e., both are 45 F) (8 C), there is no reset at this full load condition.

If this same unit is only half loaded (i.e., ENT - LVG = 5F) (-15 C), then:

$$RCWS = 45 \text{ F } + 0.5 [10 \text{ F } - 5 \text{ F}]$$

$$RCWS = 45 \text{ F } + 2.5$$

$$RCWS = 47.5 \text{ F } (9 \text{ C})$$

Example # 2:

$$DTFL = 10.0 \text{ F } (-12 \text{ C})$$

$$PCWS = 45.0 \text{ F } (8 \text{ C})$$

$$RAS = 1.0 \text{ (e.e., "100" in Table A)}$$

Chiller B is operating at full load, and the delta-T across the evaporator (ENT - LVG) is 10 F (-12 C) , so:

$$RCWS = 45 \text{ F } + 1.0 [10 \text{ F } - 10 \text{ F}]$$

$$RCWS = 45 \text{ F } = 0 \text{ F}$$

$$RCWS = 45 \text{ F } (8 \text{ C})$$

Under this full load condition, LVG and RWCS are again equal (i.e., both are 45 F) (8 C), so there is no reset.

If this same unit is only half loaded

(i.e., ENT - LVG = 5 F) (-15 C), then:

$$RCWS = 45 \text{ F } + 1.0 [10 \text{ F } - 5 \text{ F}]$$

$$RCWS = 45 \text{ F } + 1.0 [5]$$

$$RCWS = 50 \text{ F } (10 \text{ C})$$

In this situation, the chilled water setpoint will be reset 5 F (-15 C) will be reset 5 F (-15 C) upward, and the chiller will operate with an entering chilled water temperature of 55 F (13 C) and a leaving chilled water temperature of 50 F (10 C).

Notice that an RAS of 1.0 yields a constant return temperature; as unit load varies, the leaving chilled water setpoint is reset so that the entering chilled water temperature is always 55 F (13 C).

Ambient-Based CWR

When ambient-based chilled water reset is desired, the CWR controls must be adjusted as described below:

1. **Reset Type Knob:** Set at "Remote Temp".

2. **Reset Reference Knob:** This knob is used to set the temperature below or above which reset begins (i.e., design ambient). Use Table B (Figure 21) to convert the desired design ambient temperature to a letter code (i.e., "A" through "H").

Example: Chiller A's design ambient temperature is 90 f (33 C) (i.e., chilled water reset is desired if the ambient temperature falls below 90 F) (33 C).

a. Convert Chiller A's design ambient to a letter code. Locate 90 F (33 C) in Table B under "Remote Temp."; 90 F = "D".

b. Adjust the reset reference knob to control setting "D".

3. Reset Action Knob: Set at the amount of reset desire. Use the following equation and Table A (Figure 21) to determine the amount of reset desired; then convert this amount to a letter code (i.e., "A" through "H").

$$RCWS = PCWS + RAS (RRS - AMB)$$

Notes about this equation:

a. To convert the reset action values in Table A from percentages to decimal values, divide by 100. Decimal values must be used for the RAS variable in the equation.

b. Increasing the RAS to a larger number results in more reset.

c. Using a negative RAS causes the chilled water setpoint to be reset upward whenever the ambient temperature exceeds the design ambient. System control will not allow the chilled water setpoint to be reset downward even though it is possible in this equation.

Review Example 3 to ensure that you understand the correlation between the reset action setting and the reset chilled water setpoint in ambient-based chilled water reset.

Example # 3

$$\begin{aligned} PCWS &= 45.0 \text{ F (8 C)} \\ RAS &= 0.2 \text{ (e.e., "20" in Table A)} \\ RRS &= 90.0 \text{ F (33 C)} \end{aligned}$$

When the outdoor air temperature is 80 F (27 C), then:

$$\begin{aligned} RCWS &= 45 \text{ F} + 0.2 (90 \text{ F} - 80 \text{ F}) \\ RCWS &= 45 \text{ F} = 2 \text{ F} \\ RCWS &= 47 \text{ F (9 C)} \end{aligned}$$

If the outdoor air temperature drops to 70 F (22 C), then:

$$RCWS = 45 \text{ F} + 0.2 (90 \text{ F} - 70 \text{ F})$$

$$\begin{aligned} RCWS &= 45 \text{ F} + 4 \text{ F} \\ RCWS &= 49 \text{ F (33 C)} \end{aligned}$$

Thus, a RAS of 0.2 (i.e., + 20%) provides 2 F of reset for every 10 F drop in outdoor air temperature below the design ambient.

Remote Generic BAS/CWR Interface

In CVHE applications where the operator wishes to use a generic building automation system (BAS) to reset the chilled water setpoint, a "chilled water reset interface" module (1U4) must be either factory- or field-installed inside the UCP enclosure.

Once installed, the interface module "converts" a 0-10 VDC (or a 4-20 mA) output signal from the generic BAS to a usable input for the CWR module.

A special "customer information" drawing accompanies each CVHE/CVHF unit equipped with the generic BAS/CWR interface option. The wiring information operational data included on this drawing are shown in Figure 22.

Figure 22
Remote Generic BAS/CWR
Interface Option

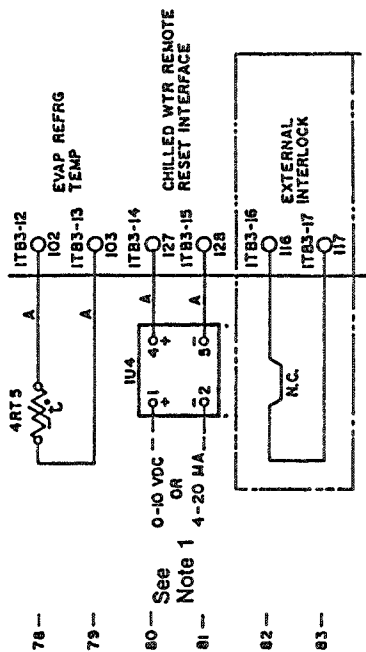

Schematic Diagram

(Use in conjunction with the schematic diagrams that shipped with the unit.)

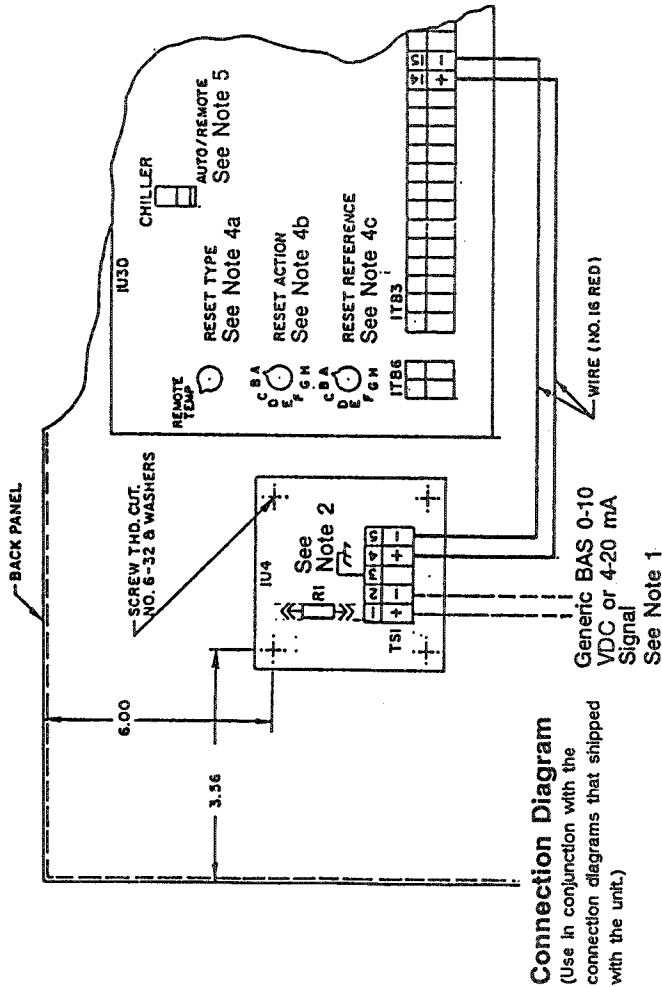

Connection Diagram

(Use in conjunction with the connection diagrams that shipped with the unit.)

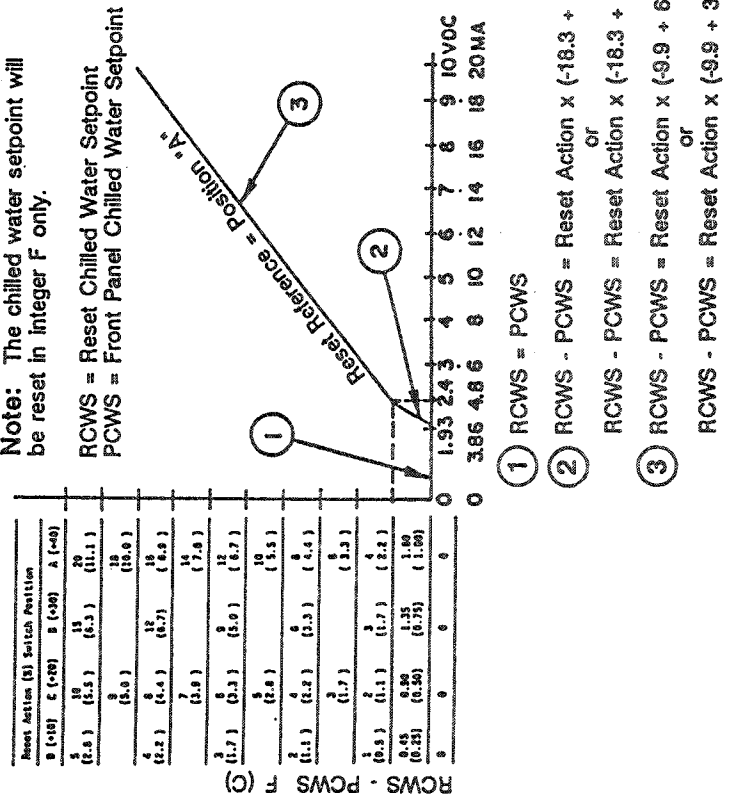

Notes:

- Negative signal inputs are grounded to the UCP's enclosure. For correct operation, external equipment signals must be isolated or floating with respect to the UCP's electrical service ground.
- Remove resistor R1 when a 0-10 VDC input is used.
- Dashed lines (---) represent field-installed wiring.
- To activate the remote generic BAS/CWR interface, complete these micro module (1U3D) control adjustments:
 - Set "Reset Type" at the "Remote Temp." position.
 - Set "Reset Action" to "A", "B", "C" or "D". (Refer to the chart at left to determine the appropriate setting.)
 - Set "Reset Reference" to the "A" position.
- To enable the remote generic BAS/CWR interface, the UCP's chiller switch must be set at "Auto/Remote".
- Maximum continuous input = 15 VDC (30 mA); minimum continuous input = -4 VDC (-8 mA). (Below these values, diagnostic code b AE will appear on the micro module [1U3D] display.)
- When the chiller is not running, the micro module (1U3D) setpoint "steps" toward the desired generic BAS setpoint at a rate of approximately 1 F (0.55 C) per second.
 When the chiller is running, 1U3D's setpoint is changed by 1 F (0.55 C) only when chilled water temperature is "in control" for 75 seconds. ("in control" is defined as the 1U3 setpoint ± X, where X varies from 0.8 to 1.6 F (0.44 to 0.88 C) based on the micro module's differential-to-start setting.)

Unit Start-up Procedures

Daily Unit Start-Up

Note: Refer to Figures 23 and 24 for UCP Start-Run-Shutdown sequence and UCP timing functions.

1. Start the chilled water pump if it was turned off at the end of the previous day.

While the chiller switch is positioned at "Standby/Reset", the UCP checks for closure of the chilled water flow switch (5S2). Illumination of the "Chilled Water Flow" status indicator light indicates that flow is established.

If flow switch 5S2 fails to close or if it reopens following a closure diagnostic b ED appears on the display.

2. Check the oil tank oil level; the level must be visible in or above the lower sight glass. Also, be sure to check the oil tank temperature; normal oil tank temperature before start-up is 140°F to 145° F (60 to 63 C).

Note: the oil heater is energized whenever power is supplied to the unit and the oil temperature is less than 140°F (60 C).

3. Verify that the vane control knob and oil pump switch are positioned at "Auto", and that the purge switch is set at "Timed".

Note: Unit start-up will not occur if the oil pump switch is in the "On" position.

4. If the chiller is equipped with the free cooling option, ensure that the free cooling switch is in the "Off" position.

5. Check the chilled water setpoint and readjust it, if necessary. (Setpoint value can be observed by pressing the advance menu

CVHE-M-6

button until code prefix "C" appears on the display.)

6. If necessary, readjust the current limit setpoint. (To determine the setpoint value, press the advance menu push-button until code prefix "d" appears on the display.)

7. Adjust the 3-position chiller switch from "Standby/Reset" to "Auto/Local" or "Auto/Remote". (The operating code appearing on the display changes from A 0 to A 1.) the UCP operation and timing functions are illustrated in Figures 23 and 24.

As state goes from A0 to A1 or A70, the logic passes through A88 briefly. As A88 is flashed all safety sensors are checked for short circuits and open circuits. If a sensor is bad, a latching diagnostic will occur indicating which sensor.

The UCP also checks compressor motor winding temperature, and a 4-minute delay is initiated if the winding temperature is less than 165° F. If it is greater than 165° F, however, a 15-minute delay period begins.

Next, the UCP checks the leaving evaporator water temperature and compares it to the chilled water setpoint. If the difference between these values is less than the start differential setpoint, cooling is not needed.

If the UCP determines that the difference between the evaporator leaving water temperature and chilled water setpoint exceeds the start differential setpoint, the unit enters the restart inhibit mode, and the "Cooling Required" status indicator light illuminates.

At the end of the restart inhibit

period, the UCP issues a signal to start the condenser water pump. The operating code appearing on the display changes from A 70 to A 71 as the UCP checks for condenser water flow. If flow is not proven (i.e., flow switch 5S3 does not close) within 3 minutes, the unit is locked out; latching diagnostic b dC will flash alternately with operating code A 71 on the display.

With condenser water flow established, the UCP checks the position of the inlet guide vanes; they must be closed before a start sequence can occur. If the vanes are open, the UCP sends a "close" signal to the actuator. A latching diagnostic (i.e., b FA flashing alternately with operating code (A 71)) occurs if vane closure is not established within 3 minutes.

Once the inlet guide vanes are closed, the unit enters the start mode (A 72) and the UCP sends a signal to begin oil pump operation. (In addition, an interval timer energizes at this time to close a solenoid valve in the oil sump vent line for a 2-minute period.)

Figure 23 UCP Start-Run-Shutdown Sequence

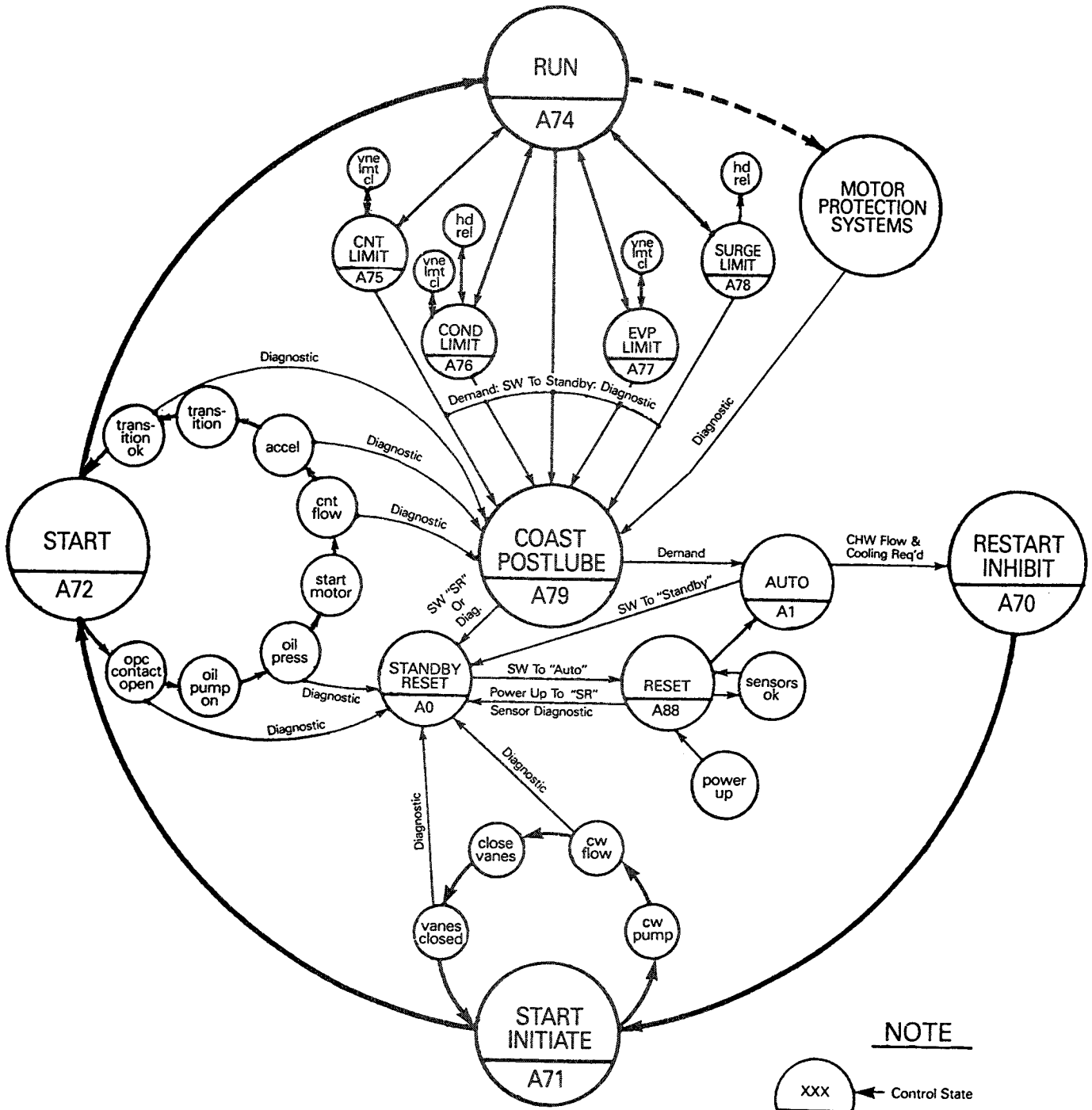

NOTE

- XXX ← Control State
- A- ← Operating Code — display menu in "A" position
- ← Substate Control

Sufficient oil pressure (i.e., 15 ± 1 psid) must be confirmed within 33 seconds, or the unit locks out on low oil pressure. (Latching diagnostic b F2 will flash alternately with operating code A 72 on the display.) A 15-second prelube cycle begins when oil pressure is successfully established.

Note: Since (a) "sufficient" oil pressure may be confirmed at any point during the 33-second "oil pressure overdue" timing interval, and (b) the 15-second "prelube" period begins only when sufficient oil pressure is sustained, the actual time required to "establish oil pressure" and "prelube" can be 15 to 48 seconds.

At the end of the prelube period, the UCP sends a start signal to the compressor motor. Within 2-seconds, 3 phases of current in the correct phase sequence must be detected if there is no current 1 or 2 phases missing, or reverse electrical sequence diagnostics will occur within the maximum acceleration time setpoint and proof of transition must occur within 2-second s of transition initiation, or unit start-up is aborted. (If this occurs, the unit goes into the post-lube mode-- A 79--and coasts to a stop. Latching diagnostic b EE or b F0 will flash on the display.)

If the compressor motor starts and accelerates successfully, operating code A 74 (Run: Normal) appears on the display and the "Running" status indicator light illuminates. At this time the purge unit will start operating on "Automatic" and will continue to operate as long as chiller compressor is running.

Note: Whenever the UCP detects a latching diagnostic condition during start-up, unit operation is locked out and manual reset is required before the start-up sequence can begin again. If the fault condition has not cleared, the UCP will not permit restart. Remember that a manual reset erases the diagnostic code identifying the fault; the display will only show operating code A 0, with no indication of what the problem was.

When the cooling requirement is satisfied, the UCP originates a "stop" signal and the unit enters a 2-minute post-lube (A 79) period. the compressor motor and condenser water pump starters are de-energized immediately, but the oil pump continues to run during this 2-minute interval; the "Running" status indicator light also remains lit during this period.

Once the post-lube cycle is complete, the unit returns to the auto (A 1) mode.

Seasonal Unit Start-Up

Note: Refer to Figures 23 and 24 for UCP Start-Run-Shutdown sequence and UCP timing functions.

1. Close all drain valves, and re-install the drain plugs in the evaporator and condenser headers.
2. Service the auxiliary equipment according to the start-up/maintenance instructions provided by the respective equipment manufacturers.
3. Vent and fill the cooling tower, if used, as well as the condenser and piping. At this point, all air must be removed from the system (including each pass). Then close the vent valves in the condenser water boxes.
4. Open all of the valves in the evaporator chilled water circuit.
5. If the evaporator was previously drained, vent and fill the evaporator and chilled water circuit. When all air is removed from the system (including each pass), close the vent valves in the evaporator water boxes.
6. Lubricate the external vane control linkage.
7. Check the adjustment and operation of each safety and operating control.
8. Close all disconnect switches.

WARNING: To prevent injury or death due to electrical shock or contact with moving parts, use care when measurements, adjustments, or other service-related operations are performed with power on.

9. Start the chilled water pump. While the chiller switch is set at "Standby/Reset", the UCP checks for closure of the chilled water flow switch (5S2), illumination of the "Chilled Water Flow" status indicator light indicates that flow is established.

If flow switch 5S2 fails to close or if it reopens following a closure diagnostic **bEd** appears on the display.

10. Check the oil tank oil level; the level must be visible in or above the lower sight glass. Also, be sure to check the oil tank temperature; normal oil tank temperature **before** start-up is 140 to 145 F (60 to 63 C).

Note: Unit start-up will **not** occur if the oil pump switch is in the "On" position.

11. If the chiller is equipped with the free cooling option, ensure that the free cooling switch is in the "Off" position.

12. Check the chilled water setpoint and readjust it, if necessary. (Set point value can be observed by pressing the advance menu button until code prefix "C" appears on the display.)

13. If necessary, readjust the current limit setpoint. (To determine the setpoint value, press the advance menu push-button until code prefix "d" appears on the display.)

14. Adjust the 3-position chiller switch from "Standby/Reset" to "Auto/Local" or "Auto/Remote".

Unit Shutdown Procedures

Daily Unit Shutdown

Note: Refer to Figures 23 and 24 for UCP Start-Run-Shutdown sequence and UCP timing functions.

1. Adjust the chiller switch to the "Standby/Reset" position.
2. If desired, turn off the chilled water pump.

Seasonal Unit Shutdown

Note: Refer to Figures 23 and 24 for UCP Start-Run-Shutdown sequence and UCP timing functions.

1. Adjust the chiller switch to the "Standby/Reset" position.
2. If desired, turn off the chilled water pump at the pump's push-button station. (Or, stop chilled water flow by the means devised for this particular application.)
3. Open all disconnect switches except the control power disconnect switch.

WARNING: To prevent injury or death due to electrical shock or contact with moving parts, use care when servicing system with power on.

Caution: Control power disconnect must remain closed during entire shutdown period to allow oil sump heater operation. This prevents refrigerant from condensing in oil sump.

4. Drain the condenser piping and cooling tower, if used.
5. Remove the drain and vent plugs from the condenser headers to drain the condenser.

6. Once the unit is secured for winter, the maintenance procedures described under "Annual Maintenance" in the Periodic Maintenance section of this manual should be performed by qualified Trane service technicians.

Note: During extended shutdown, be sure to operate the purge unit for a 2-hour period every 2 weeks. This will prevent the accumulation of air and non-condensibles in the machine. To start the purge, adjust purge switch to the "Manual" position.

CAUTION: Do not allow the chiller to increase in temperature (pressure) while the unit is off to temperature above 110°F (43C) since this will cause the rupture disk to relieve and discharge the refrigerant from the machine. Continuous running of pumps while the machine is off may cause this condition to occur. The rupture disk is designed to relieve if the pressure in the evaporator exceeds 15 psig.

Periodic Maintenance

Overview

This section describes basic chiller preventive maintenance procedures, and recommends the intervals at which these procedures should be performed. Use of a periodic maintenance program is important to ensure the best possible performance and efficiency from a CenTraVac chiller.

Recommended purge maintenance procedures for the Purifier Purge unit are covered by PRG-OM-4.

An important aspect of the chiller maintenance program is the regular completion of a CenTraVac "Operating Log". An example of this log is provided in this manual. When filled out accurately by the machine operator, the completed logs can be reviewed to identify any developing trends in the chiller's operating conditions.

Table 6
Normal Chiller Operating Characteristics

For example, if the machine operator notices a gradual increase in condensing pressure during a month's time, he can systematically check, then correct the possible cause(s) of this condition (e.g., fouled condenser tubes, non-condensibles in the system, etc.)

Daily Maintenance and Checks

[] Check the chiller's evaporator, condenser and purge drum pressures, oil sump pressure, and net oil pressure. Compare the readings obtained with the values provided in Table 6.

Caution: If frequent purging is required (i.e., monitor purge timer, identify and correct source of air or water leak as soon as possible. Moisture contamination caused by leakage can shorten chiller life expectancy.

[] Check the oil level in the chiller oil sump using the 2 sight glasses provided in the oil sump head. When the unit operating, the oil level should be visible in the lower sight glass.

Weekly Maintenance

[] Complete all daily maintenance procedures and checks.

Note: If the unit is operating in the cooling mode, close the manual shutoff valves on the heating condenser and open the valves on the cooling condenser. Reverse this procedure when the unit is operating in the heat-recovery mode.

Operating Characteristic	Normal Reading
Evaporator Pressure	12 to 18" Hg (vacuum)
Condenser Pressure (see Notes 1, 2)	2 to 12 psig (standard condensers)
Purge Drum Pressure	0 to 25 psig
Oil Sump Temperature:	
Unit Not Running	140 to 145 F (60 to 63 C)
Unit Running	115 to 150 F (47 to 66 C)
Net Oil Pressure	12 to 18 psid

Notes:

1. Condenser pressure is dependent on condenser water temperature, and should equal the saturation pressure of R-11 at a temperature 5-10 F (-15 to -12 C) above that of leaving condenser water at full load.
2. Normal pressure readings for ASME condensers exceed 12 psig.
3. Net oil pressure (i.e., usable oil pressure) is determined by subtracting the low oil pressure value from the high oil pressure gauge reading.

Example:

High oil pressure gauge = 9 psig;
Low oil pressure gauge = 18" Hg (vacuum).

First, convert 18" Hg to psig (i.e., $-18/2.03 = -8.87$ psig). Then, subtract -8.87 psig from 10 psig (i.e., $10 - [-8.87] = 9 + 8.87 = 17.87$ psid). In this example, the net oil pressure of 17.87 psid is within the acceptable limits.

60 Hz
 CenTraVac® Operating Log
 For CVHB/E/F w/UCP695



The Trane Company
 An American Standard Company

Job Name		Date					
Unit/Tag #							
Model #		Time					
Serial #							
FULL LOAD DESIGN	REF MONITOR LEVEL						
	OPERATING COND						
	OPERATING CODE						
	LAST DIAGNOSTIC						
DEG F _____ >	LCHW SETPOINT						
	CNT LIMIT SP						
	CHILLER STARTS						
	CHILLER RUN HRS						
DESIGN VOLTS _____ >	VOLTAGE AB						
	VOLTAGE AB						
HERTZ _____	VOLTAGE BC						
	AMPERAGE L1						
RLA _____ >	AMPERAGE L2						
	AMPERAGE L3						
	AMP AVG						
	% OF RLA						
125 - 150 DEG >	OIL SUMP TEMP						
	OIL TEMP TO BRGS						
	OIL LEVEL						
	LO OIL PRESS						
	HI OIL PRESS						
	NET OIL PRESS						
	PURGE RUN HRS						
	CHW PSID						
_____ PSID _____ GPM	CHW TEMP IN						
DEG F _____ >	CHW TEMP OUT						
DEG F _____ >	CHW TEMP DIFF						
DEG F _____ >	EVAP TEMP						
	EVAP PRESS						
	CW PSID						
_____ PSID _____ GPM	CW TEMP IN						
DEG F _____ >	CW TEMP OUT						
DEG F _____ >	CW TEMP DIFF						
DEG F _____ >	COND TEMP						
	COND PRESS						
	OPER INITIALS						
COMMENTS:							

LOP/2 + HOP = Net Oil Pressure, CHW = Chilled Water, CW = Condenser Water

Every 3 Months

WARNING: To prevent injury or death due to electrical shock or contact with moving parts, lock unit disconnect switch in open position.

Complete all recommended weekly maintenance procedures. (Refer to the previous sections for details.)

Clean all water strainers in the CenTraVac water piping system.

Every 6 Months

WARNING: To prevent injury or death due to electrical shock or contact with moving parts, lock unit disconnect switch in open position.

Complete all recommended quarterly maintenance procedures.

Lubricate the vane control linkage bearings, ball joints, and pivot points; a few drops of light machine oil (e.g., SAE-20) is sufficient.

Drain the contents of the rupture disc/purge discharge vent line drip leg into an evacuated waste container at a minimum and more often if the purge operated excessively.

Also, apply 1 or 2 drops of oil on the vane operator shaft and spread it into a very light film; this will protect the shaft from moisture and rust.

Off-Season Maintenance

During those periods of time when the chiller is not operated, **be sure control panel is energized.**

Annual Maintenance

Shut down the chiller once each year to check the items listed below; a more detailed inspection checklist is provided on the "Model CVHE CVHF CenTraVac Annual Inspection Checklist and Report" illustrated in this manual.

Perform the annual maintenance referred to in the Maintenance Section of the purge manual.

Use an ice water bath to verify that the accuracy of the evaporator refrigerant temperature sensor (4RT5) is still within tolerance (i.e., ± 2.0 F at 32 F).

If the evaporator refrigerant temperature displayed on the UCP's read-out is outside this 4-degree tolerance range, replace the sensor.

Note: If the sensor is exposed to temperature extremes outside its normal operating range (0 F to 90 F) (-18 C to 32 C), check its accuracy at 6-month intervals.

Compressor Oil Change on CVHE /CVHF units.

Recommendations are to subscribe to an oil analysis program to determine the necessity to change oil, rather than change it automatically every year. This will reduce the chiller's overall lifetime oil consumption and minimize refrigerant emissions. A drain fitting should be installed in the oil line after the oil filter for obtaining oil samples.

Oil Change Procedure

When oil analysis indicates the need to change compressor oil, use the following procedure for removing oil.

CAUTION: To prevent possible burnout of the oil sump heater, be sure to open control panel disconnect switch before draining the sump.

Draw the oil from the chiller through the oil charging valve on the chiller oil sump into an approved, evacuated tank, or;

Pump the oil from the chiller through the oil charging valve into an air-tight resealable container, using a magnetically-driven auxiliary pump.

Forcing the oil from the oil sump by pressurizing the chiller (i.e. by raising chiller temperature or adding nitrogen) is NOT recommended.

Refrigerant dissolved in the oil can be removed and returned to the chiller by using an appropriate deep-vacuum recovery unit and heating/agitating the oil container. Follow all Federal, state and local regulations with regard to disposal of waste oil.

Replacing Oil Filter

Replace oil filter: (1) annually, (2) at each oil change, (3) or if erratic oil pressure is experienced during chiller operation.

Replacement Procedure

Run oil pump for two to three minutes to insure that the oil filter is warmed up to oil sump temperature.

Close the shutoff valves before and after the filter and open the filter drain valve. Time required to drain oil can be momentarily opening the oil sampling drain valve.

Allow time for the filter to drain. Remove filter and place into a resealable container. Follow all

Annual Inspection Check List and Report: CVHEs/CVHF's w/UCP695 Control Panels

Review unit with operating personnel.

Compressor Motor

- Motor continuity check
Good Open
- Check and tighten motor terminals
- Meg motor
Phase 1 ___ Phase 2 ___ Phase 3 ___
- Check nameplate rating
Amps ___

Starter

- Check condition of starter contacts
Good Fair Replace

Oil Sump

- Change oil
If oil analysis, refer to program procedures.
___ Gallons (7) required
- Check oil condition
Good Fair Poor
- Oil pump continuity test
Good Open
- Oil pump motor ground check
Good Bad
- Check motor terminals
- Change oil filter

Condenser

- Visually inspect for scaling in tubes:
note findings and make recommendations.

Comments: _____

Recommendations: _____

Control Circuits

- Low temperature control calibration
___ F set point ___ F trip point (ice water)
- High pressure control calibration
___ psig setpoint
___ psig trip point (oil-pumped dry nitrogen)
- Oil pressure control calibration
___ psid cut-in
___ psig cut-out
- Check adjustment and calibration of inlet guide
vane actuator motor

Leak Test Chiller

Refrigerant and oil analysis for acid content.

- Sample refrigerant and oil for laboratory analysis
(attach copy of analysis to next monthly inspection report)

Purge Unit

- Check purge unit/controls for proper operation.
- Check moisture indicator, replace filter-drier cores
as necessary.
- Check purge tank sump for water, remove free
water as necessary.
- Inspect/clean air-cooled condenser coil as
necessary.

Cover Logs/Logging System with Operator

- Review proper logging procedures with
operator.

Important: This check list is intended for use by qualified Trane service organizations ONLY. It is not a part of the maintenance operations performed by the CVHE owner/operator.

federal, state and local regulations with regard to disposal of the filter.

Note: If the unit is under positive pressure, the entering and leaving lines at the oil filter must be disconnected. Be sure to plug the open end of each line with a flare fitting plug to reduce refrigerant loss during the filter change-out procedure.

Other Maintenance Requirements

Inspect the condenser tubes for fouling; clean if necessary.

Measure the compressor motor winding resistance to ground; a Qualified service technician should conduct this check to ensure that the findings are properly interpreted.

Contact a qualified service organization to leak-test the chiller; this procedure is especially important if the system requires frequent purging.

Use a nondestructive tube test to inspect the condenser and evaporator tubes at 3-year intervals.

Note: It may be desirable to perform tube tests on these components at more frequent intervals, depending upon chiller application. This is especially true of critical process equipment.

Depending on chiller duty, contact a qualified service organization to determine when to conduct a complete examination of the unit to discern the condition of the compressor and internal components.

a. chronic air leaks, which can cause acidic conditions in the compressor oil and result in

premature bearing wear; and,

b. evaporator or condenser water tube leaks. Water mixed with the compressor oil can result in bearing pitting, corrosion, or excessive wear.

Submit a sample of the compressor oil to a Trane qualified laboratory for comprehensive analysis on an annual basis; this analysis determines system moisture content, acid level and wear metal content of the oil, and can be used as a diagnostic tool.

Lubrication

The only CVHE/CVHF chiller component that requires periodic lubrication is the external vane linkage assembly.

Lubricate the vane linkage shaft bearings and rod end bearings with a few drops of light-weight machine oil.

Refrigerant Charge

WARNING: To avoid injury or death due to inhalation of, or skin exposure to refrigerant, closely follow all safety procedures described in the Material Safety Data Sheet for the refrigerant containers. Certain procedures common to refrigeration system service may expose operating and/or servicing personnel to liquid and/or vaporous refrigerant.

The refrigerant charging procedure for Trane centrifugal chillers is:

1. If water is present in the tubes, break machine vacuum with refrigerant vapor, or circulate water, to avoid tube damage.

2. Always use refrigerant-compatible hoses or copper-tubing with self-sealing con-

nections or shut-off valves.

3. Transfer the refrigerant using one of the following (listed in order of preference):

- a. An approved Trane low-pressure refrigerant recovery/recycle unit.
- b. The available pressure differential.
- c. Gravity. (Use a return vent line to refrigerant drums to equalize pressure.)
- d. A mechanical gear pump with compatible seals, or a magnetically-driven pump.

4. When charging from new drums, use fitting designed for use with 3/4-inch center drum bung of 2-inch bung.

5. Do not use dry nitrogen to push refrigerant into the chiller as was common practice in the past. This will contaminate the charge require excessive purging, which will result in unnecessary release of refrigerant.

6. Weigh in the proper charge.

7. Use recovery/recycle unit or vacuum pump to evacuate hoses; discharge outdoors.

Recovery/Recycle Connections

To facilitate refrigerant removal and replacement, newer-design CVHE and CVHF units are provided with a 3/4-inch vapor fitting with shutoff valve on the chiller suction and with a 3/4-inch liquid connection with shutoff valve at the bottom of the evaporator shell.

Recovery/Recycle Connections

To facilitate refrigerant removal and replacement, newer-design CVHE and CVHF units are provided with a 3/4-inch vapor fitting with shutoff valve on the chiller suction and with a 3/4-inch liquid connection with shutoff valve at the bottom of the evaporator shell.

Leak Testing

To leak-test a chiller containing full refrigerant charge, raise chiller pressure using a controlled hot water or electric-resistance system to a maximum of 8 psig. Do not use nitrogen, which will cause excessive refrigerant discharge by the purge system.

Figure 25
Trane-Designed Drum Bung Fitting
w/Quick-Connect Coupling

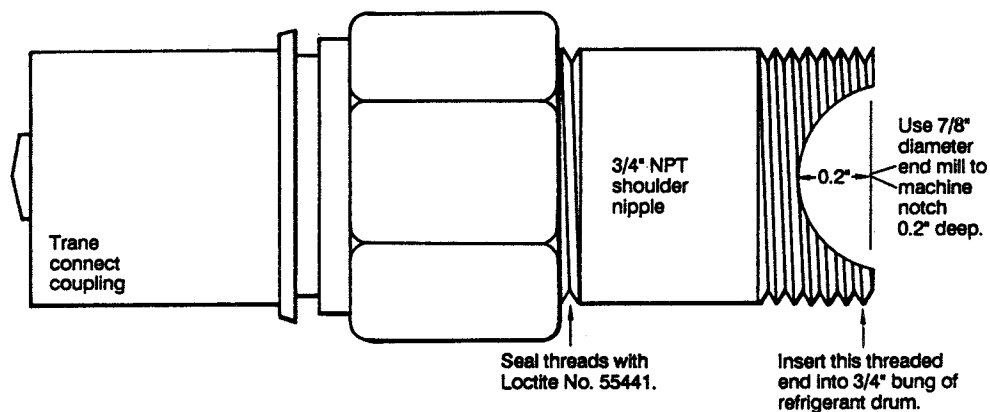

Periodic Maintenance

Cleaning the Condenser

CAUTION: Do not use untreated or improperly treated water, or equipment damage may occur.

Condenser tube fouling is indicated when "the approach" temperature (i.e., the difference between the refrigerant condensing temperature and the leaving water temperature) is higher than predicted.

If the annual condenser tube inspection indicates that the tubes are fouled, 2 cleaning methods mechanical and chemical can be used to rid the tubes of contaminants.

Use the mechanical cleaning method to remove sludge and loose material from smooth-bore tubes.

(To clean other types of tubes including internally-enhanced types, consult a qualified service organization for recommendations.)

1. Remove the retaining nuts and bolts from the water box covers at each end of the condenser. Use a hoist to lift the covers off the water box (A threaded connection is provided on each water box cover to allow insertion of an eyebolt.)

2. Work a round nylon or brass bristled brush (attached to a rod) in and out of each of the condenser water tubes to loosen the sludge.

3. Thoroughly flush the condenser water tubes with clean water.

Scale deposits are best removed by chemical means. Be sure to consult any qualified chemical house in the area (i.e., one familiar with the local water supply's chemical/mineral content) for a recommended cleaning solution suitable for the job. (Remember a standard condenser water circuit is composed solely of copper, cast iron and steel.)

A typical chemical cleaning setup is illustrated in Figure 26.

Figure 26
Typical Chemical Cleaning Setup

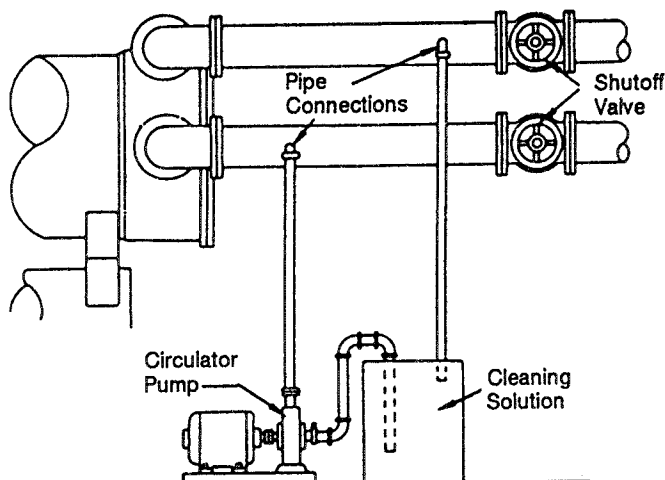

CAUTION: Improper chemical cleaning can damage tube walls.

CAUTION: All of the materials used in the external circulation system, the quantity of the solution, the duration of the cleaning period, and any required safety precautions should be approved by the company furnishing the materials or performing the cleaning.

Remember, however, that whenever the chemical tube cleaning method is used, it must be followed up with mechanical tube cleaning, flushing and inspection.

Cleaning the Evaporator

Since the evaporator is typically part of a closed circuit, it does not accumulate appreciable amounts of scale or sludge. Normally every 3 years is sufficient. However on open CVHE/CVHF systems such as air washers periodic inspection and cleaning is recommended.

Control Settings And Adjustments

A list of CVHE/CVHF time delays and safety control cutout settings is provided in Table 1 in the Chiller Control System section of this manual. For control calibration and check-out, contact a Trane qualified service organization.

Purge System

Because some sections of the chiller's-refrigeration system operate at less-than-atmospheric pressure, the possibility exists that air and moisture may leak into the system. If allowed to accumulate, these non-condensibles become trapped in the condenser; this increases condensing pressure and compressor power requirements, and reduces the chiller's efficiency and cooling capacity.

The Trane Purifier Purge is the only purge system available for the CVHE/CVHF chiller. The purge is designed to remove non-condensable gasses and water from the refrigeration system. Purifier Purge unit operation, maintenance and troubleshooting is covered by a separate operation and maintenance manual (PRG-OM-4).

Trouble Analysis

Note: The troubleshooting charts in this manual are provided solely as a guide for determining the cause of a mechanical failure or equipment malfunction. When operational problems do occur, always contact a qualified service organization to ensure proper diagnosis and repair of the chiller.

UCP695 Control System

As described in the Chiller Control System section of this manual, the UCP-695 control panel visually indicates operating and diagnostic codes at the display window.

If the UCP detects a diagnostic condition, the display alternately flashes the unit operating mode (code prefix A) at the time the unit shut down and diagnostic code (code prefix b). Complete listings of the codes used to identify CVHE/CVHF operating modes and diagnostic conditions are provided in Tables 3 and 4. (See "Operator Interface: Display" in Chiller Control System.)

Organization of the UCP troubleshooting charts on the following pages is based on the possible 3-digit diagnostic codes that may appear on the display at one time or another.

Notice that each diagnostic code is classed by type ("latching" or "non-latching"); the condition that generated the diagnostic is then described briefly. Suggested actions for correcting the problem are provided under "Recommended Action".

Note: Remember that nonlatching diagnostics allow automatic restart as soon as the diagnostic condition clears, while latching diagnostics require a manual reset before unit operation can resume. The "Manual Reset Required" status indicator light illuminates

whenever a latching diagnostic occurs.

UCP "Summary Sheet"

Immediately following the troubleshooting charts just described, is a 2-page owner/operator guide to the UCP's micro module (1U3).

Use this summary sheet as a quick reference for identifying operating and diagnostic codes that appear on the UCP's display. Also included there are lists of the micro module's timing functions, run inhibit points, and inputs (including terminal connection designations).

Troubleshooting Charts

UCP-Generated Diagnostics

3-Digit Diagnostic Code	Type (1)	Diagnostic Description	Recommended Action
b A3	L	Evaporator Refrigerant Temperature Range	Check evaporator "trip" setting.
b A4	L	Motor Temperature Sensor #1 (4B1R2)	Check sensor connections.
b A5	L	Maximum Acceleration Time Range	Contact a qualified service organization.
b A7	L	Motor Temperature Sensor #2 (4B1R3)	Check sensor connections.
b A8	L	Motor Temperature Sensor #3 (4B1R4)	Check sensor connections.
b A9	L	Oil Temperature Sensor 4RT7	Check sensor connections.
b Ab	L	Leaving Water Temperature Sensor 4RT1	Check sensor connections.
b AC	L	Condenser Refrigerant Pressure Sensor 1R1 (optional)	Check sensor connections.
b Ad	L	Evaporator Refrigerant Temperature Sensor 4RT5 (optional)	Check sensor connections.
b AE	L	Ambient Temperature Sensor 4RT6 (optional)	Check sensor connections.
b AF	L	Inboard Bearing Temperature Sensor #1 (4RT8; optional)	Check sensor connections.
b b0	L	Outboard Bearing Temperature Sensor #2 (4RT9; optional)	Check sensor connections.
b d9	NL	Extended Power Loss	None. Power lost; unit restarted normally when power was restored.
b dA	L	Surge	Check for proper operating conditions (entering condenser water temperature, flow rate, etc.). Also check for air dirty tubes and air in condenser.
b dC	L	Condenser Water Flow Overdue	Check condenser water flow switch, valves and pump contactor.
b E2	NL	Momentary Power Loss	None. Power lost briefly; unit restarted normally when power was restored.
b E3	L	Phase Imbalance	Contact a qualified service organization.
b E4	L	Phase Loss	Contact a qualified service organization.
b E5	L	Phase Reversal	Contact a qualified service organization.
b E7	L	High Motor Temperature (4B1R2, 4B1R3 or 4B1R4)	Contact a qualified service organization.
b E8	L	Differential Oil Pressure Switch 1S2	Contact a qualified service organization.
b E9	L	Stop Relay 1U2K2	Contact a qualified service organization.

Notes: See conclusion of "Troubleshooting Charts: UCP-Generated Diagnostics" on next page.

UCP-Generated Diagnostics

3-Digit Diagnostic Code	Type (1)	Diagnostic Description	Recommended Action
b EA	L	High Inboard Bearing Temperature, Sensor #1 (4RT8)	Check for proper oil sump heater (and oil cooler on CVHE 360 thru 1250) operation.
b Eb	L	High Outboard Bearing Temperature, Sensor #2 (4RT9)	Check for proper oil sump heater operation.
b EC	L	Running Overload (1U2K3)	Contact a qualified service organization.
b Ed	NL	Chilled Water Flow	Check chilled water flow switch, valves and pump interlock.
b EE	L	Exceeded Maximum Acceleration Time	Contact a qualified service organization.
b F0	L	Transition	Contact a qualified service organization.
b F1 (4)	L	Running External Interlock (optional)	Identify and correct problem that triggered interlock.
b F2	L	Low Oil Pressure (1S2)	Check oil level in oil sump.
b F3 b F4	NL L	Low Oil Temperature (4RT7) High Oil Temperature (4RT7)	Check oil heater and sensors for proper operation.
b F5	L	High Condenser Refrigerant Pressure (1R1)	Check for proper operation. Also check for dirty tubes and air in condenser.
b F7	NL	Condenser Water Flow	Check condenser water flow switch valves and pump interlock circuit.
b F8	L	Improper Unit Identification	Contact a qualified service organization.
b F9	L	Free Cooling Valves (4B12, 4B13)	Contact a qualified service organization.
b FA	L	Actuator (4B2)	Contact a qualified service organization.
b Fb	L	Low Evaporator Refrigerant Temperature (4RT5)	Contact a qualified service organization.
b Fd	L	External Interlock (optional)	Identify and correct problem that triggered interlock.
b FF	L	Unit Control Module (1U3)	Contact a qualified service organization.

Notes:

1. Latching diagnostic conditions (L) require manual reset; "Manual Reset Required" status indicator light illuminates whenever a latching diagnostic condition occurs. Nonlatching diagnostic conditions (NL) do not require a manual reset; the unit automatically restarts as soon as the diagnostic condition clears.

2. Notice that the chiller will not start if the oil temperature is too low (<140 F); contact a qualified service organization for recommendations.

3. It is not possible to clear a latching diagnostic condition from a higher-level, supervisory control device (e.g., SCP699, Trane BAS or generic BAS).

4. HGBP only - bF1 is generated when condenser discharge temperature exceeds 210 F.

UCP Summary Sheet

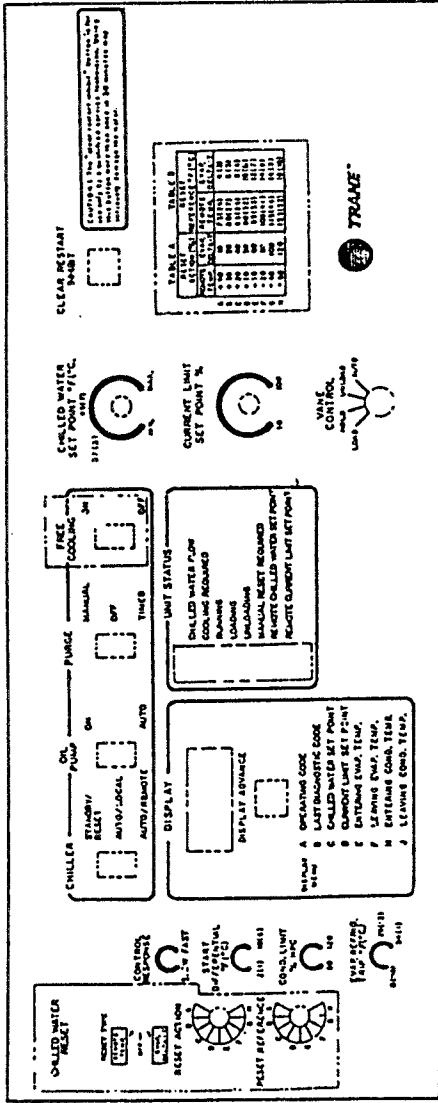

Terminal Block 1TB6 Input

Term. Nos.	Description of Input	Term. Nos.	Description of Input
1	Optional Bidirectional Communications Link	14, 15	Ambient Temp. (Opt.)

Unit Timers

Timer	Mon. Interval
Prelube*	15 seconds
Restart Inhibit (Standby--Auto):	
Winding Temp. <165 F (74 C)	2 minutes
Winding Temp. >165 F (74 C)	15 minutes
Since Last Start	30 minutes
Post-Lube	2 minutes
Free-Cool/Vane Open Inhibit	3 minutes
Purge	5 minutes ON, 115 minutes OFF

*Since (a) "sufficient" oil pressure may be confirmed at any point during the 33-second "oil pressure, over-ride" timing interval, and (b) the 15-second "pre-lube" period begins only when sufficient oil pressure is sustained, the actual time required to "establish oil pressure" and "pre-lube" can be 15 to 49 seconds.

Terminal Block 1TB3 Inputs

Term. Nos.	Description of Input	Term. Nos.	Description of Input
1, 2	Leaving Evaporator Water Temperature	16, 17	External Interlock (Opt.)
3, 4	Entering Evaporator Water Temperature (Opt.)	18, 19	Free-Cool Valves Closed (Opt.)
5, 6	Leaving Condenser Water Temperature (Opt.)	20, 21	Proof of Chilled Water Flow
7, 8	Entering Condenser Water Temperature (Opt.)	22, 23	Proof of Condenser Water Flow
9	Cond. Refrig. Pressure (POW)	24, 25	Vanes Closed
10	Cond. Refrig. Pressure (UIP)		
11	Cond. Refrig. Pressure (COH)		

Terminal Block 1TB4 Inputs

Term. Nos.	Description of Input	Term. Nos.	Description of Input
1, 2	Differential Oil Pressure	13, 14	Oil Temperature
3, 4	Running External Interlock (Opt.)	15	Winding Temperature #1
		16	Winding Temperature #2
5, 6	Transition Complete	17	Common
		18	Winding Temperature #3
7	Phase Current 3+	19, 20	Bearing Temperature #1 (Opt.)
8	Phase Current 3-		
9	Phase Current 2+	21, 22	Bearing Temperature #2 (Opt.)
10	Phase Current 2-		
11	Phase Current 1+		
12	Phase Current 1-		

Nominal Fault Timeouts

Condition	Timing Interval
Oil Pressure Overdue*	33 seconds
Transition Completion Overdue	2 seconds
Condenser Water Flow Overdue	3 minutes
Vane Closure Overdue	3 minutes
Free-Cooling Valve Closure Overdue	3 minutes

*"Sufficient" oil pressure may be confirmed at any point during this 33-second period; pre-lube begins as soon as oil pressure is confirmed.

Predetermined Unit Cutout Points (Nominal)

Condition	Cutout Point
Winding Temperature	130 C
Run Inhibit	265 F
Oil Temperature	(82 C)
Run Inhibit	180 F
Bearing Temperature	(82 C)
Run Inhibit	180 F
Leaving Chilled Water Temperature Low Limit	(2 C)
	35.3 F, range only

UCP-Generated Diagnostics

3-Digit Code	Diagnostic Description	Diagnostic Type	System Reset
b A3	Evaporator Refrigerant Temp. Range	Latching	Manual
b A4	Motor Temperature Sensor #1	Latching	Manual
b A5	Maximum Acceleration Time Range	Latching	Manual
b A7	Motor Temperature Sensor #2	Latching	Manual
b A8	Motor Temperature Sensor #3	Latching	Manual
b A9	Oil Temperature Sensor	Latching	Manual
b Ab	Leaving Water Temperature Sensor	Latching	Manual
b Ac	Condenser Refrig. Pressure Sensor (Opt.)	Latching	Manual
b Ad	Evaporator Refrig. Temp. Sensor (Opt.)	Latching	Manual
b Ae	Ambient Temperature Sensor (Opt.)	Latching	Manual
b Af	Inboard Bearing Temp. Sensor #1 (Opt.)	Latching	Manual
b B0	Outboard Bearing Temp. Sensor #2 (Opt.)	Latching	Manual
b d9	Extended Power Loss	Nonlatching	Automatic
b dA	Surge	Latching	Manual
b dC	Condenser Water Flow Overdue	Latching	Manual
b E2	Momentary Power Loss	Nonlatching	Automatic
b E3	Phase Imbalance	Latching	Manual
b E4	Phase Loss	Latching	Manual
b E5	Phase Reversal	Latching	Manual
b E7	High Motor Temperature	Latching	Manual
b E8	Differential Oil Pressure Switch	Latching	Manual
b E9	Stop Relay	Latching	Manual
b Ea	High Inboard Bearing Temp. (Sensor #1)	Latching	Manual
b Eb	High Outboard Bearing Temp. (Sensor #2)	Latching	Manual
b Ec	Running Overload	Latching	Manual
b Ed	Chilled Water Flow	Nonlatching	Automatic
b Ee	Exceeded Maximum Acceleration Time	Latching	Manual
b F0	Transition	Latching	Manual
b F1	Running External Interlock (Opt.)	Latching	Manual
b F2	Low Oil Pressure	Latching	Manual
b F3	Low Oil Temperature	Nonlatching	Manual
b F4	High Oil Temperature	Latching	Manual
b F5	High Condenser Refrigerant Pressure	Latching	Manual
b F7	Condenser Water Flow	Nonlatching	Automatic
b F8	Improper Unit Identification	Latching	Manual
b F9	Free-Cooling Valves	Latching	Manual
b FA	Actuator	Latching	Manual
b Fb	Low Evaporator Refrigerant Temperature	Latching	Manual
b Fd	External Interlock (Opt.)	Latching	Manual
b Ff	Unit Control Module	Latching	Manual

Note: It is not possible to clear a "latching" unit diagnostic condition from a higher-level, supervisory control device (e.g., SC-9599 system control panel, Trane BMS, etc.).

Display Menus

Operator's Menu (Vane control switch set at "Hold")			
Code Prefix	Parameter Description	Code Prefix	Parameter Description (and Display Range)
A	Operating Mode (see Table 3)	A	Operating Mode (see Table 3)
b	Last Diagnostic (see Table 4)	b	Last Diagnostic (see Table 4)
C	Active Chilled Water Setpoint: Std. Range = 37 F thru 60 F (-3 C thru 16 C); Extd. Range = 20 F thru 70 F (-6 C thru 22 C)	-	Panel Chilled Water Setpoint (---, 20 F thru 70 F, ---) (---, -6 C thru 22 C, ---)
d	Active Current Limit Setpoint (40% thru 100% RLA)	-	Panel Current Limit Setpoint (---, 40% thru 100% RLA, ---)
E	Entering Evaporator Water Temperature (Opt.) (---, 12 F thru 91 F, ---) (---, -11 C thru 33 C, ---)	-	Evaporator Refrigerant Temperature (2) (b Ad, -4 F thru 42 F, ---) (b Ad, -20 C thru 6 C, ---)
F	Leaving Evap. Water Temp. (b Ab, 12 F thru 91 F, ---) (b Ab, -11 C thru 33 C, ---)	-	Control Response Setpoint (1 thru 237)
H	Ent. Cond. Water Temp. (Opt.) (---, 28 F thru 142 F, ---) (---, -2 C thru 62 C, ---)	-	Start Differential Setpoint (2 F thru 10 F) (-17 C thru -12 C)
J	LV6. Cond. Water Temp. (Opt.) (---, 28 F thru 142 F, ---) (---, -2 C thru 62 C, ---)	-	Condenser Limit Setpoint (80% thru 120% HPC)
L	Multi-Use Temperature (4) (---, -5-135 F, ---)	-	Evaporator Refrigerant "Trip" Setpoint (b A3) Std. Range = 29 F thru 34 F (-1 C thru 1 C) Extd. Range = 0 F thru 34 F (-18 C thru 1 C)

Notes:

1. To redefine the "operator's menu" to the "serviceman's menu" turn vane control switch to HOLD. 2. For additional information on any item listed in the "serviceman's menu", contact a qualified service organization. 3. Actual measured evaporator refrigerant temperature. 4. Examples of "Multi-Use Temp." applications are: Cond. Lvg. Refig. Temp.; CWR Ambient Temp.; CWR Temp. from Analog Input.

Codes for Operating Modes

3-Digit Code	Operating Mode Description
Blank	Power Off
A 0	Standby/Reset
A 1	Auto
A 9	Free Cooling
A 70	Restart Inhibit
A 71	Establish Cond. Water Flow
A 72	Start
A 74	Run: Normal
A 75	Run: Current Limit
A 76	Run: Condenser Limit
A 77	Run: Evaporator Limit
A 78	Run: Surge Condition
A 79	Post-Lube
A 88	Reset