



Supplement

CTV-SUPL-1A

Library	Service Literature
Product Section	Refrigeration
Product	Centrifugal Liq. Chiller, Water-Cooled
Model	CVHB, CVHE, CVHF
Literature Type	Supplement
Sequence	1A
Date	May 1992
File No.	SV-RF-CTV-CTV-SUPL-1A-592
Supersedes	CTV-SUPL-1 Dated 1291

Supplement To:

- CVHB-IN-5A
- CVHB-M-5A
- CVHE-IN-6
- CVHE-XIN-1
- CVHE-M-5
- CVHE-XM-1

Cooling-Only and Heat-Recovery,
Direct-Drive, CVHB, CVHE and
CVHF w/UCP-695 Control Panel

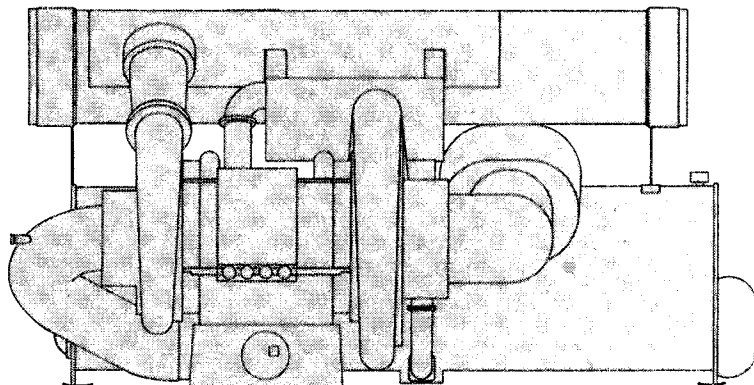
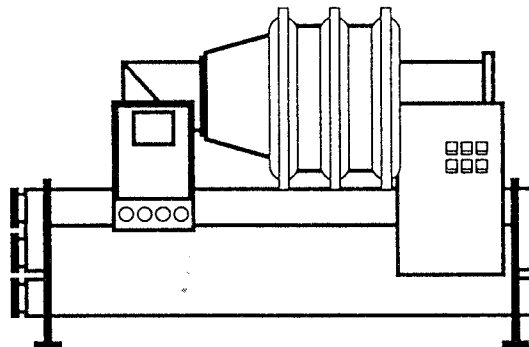

Part No. X39640371-02

Since the Trane Company has a policy of continuous product improvement, it reserves the right to change specifications and design without notice. The installation and servicing of the equipment referred to in this booklet should be done by qualified, experienced technicians.

Table of Contents

<ul style="list-style-type: none"> 3 General Information 3 Literature Change History 3 Refrigerant Requirements 3 About this Manual 4 Installation 4 Unit Weights 4 Purifier Purge Requirements 4 -- Purge Installation 4 -- Purge Water Connections 4 -- Drier-Core Installation 4 -- Purge Set-Up DIP Switch 5 Refrigerant Vent-Line Piping 5 -- General Recommendations 5 -- Purge Discharge Vent Line 5 -- Rupture Disc Vent Line 6 Chiller Water Piping Connections 7 -- Grooved-Pipe Coupling 8 -- Flange Connection Adapters 10 Electrical Wiring 10 -- Remote On/Off Control 10 -- Remote Purge Fault Indicator 10 Alarm Relay Package 11 Power Factor Correction Capacitors 11 Unit Start-Up 18 Mechanical Operation - CVHF 18 Overview 18 Cooling-Only Cycle 18 Free Cooling, Heat Recovery and Auxiliary Condenser Cycles 21 Compressor Lubrication System 21 Motor Cooling System 21 Purge System 	<ul style="list-style-type: none"> 24 Chiller Control System 24 Operator Interface 24 -- Chiller Switch 24 --- Standby/Reset 24 --- Auto/Local 24 --- Auto/Remote 25 -- Oil Pump Switch 25 --- On 25 --- Auto 25 -- Purge Switch 25 --- Manual 25 --- Off 25 --- Auto 25 -- Chilled Water Setpoint 25 -- Current Limit Setpoint 25 -- Vane Control Switch 25 --- Load 26 --- Hold 27 --- Unload 27 --- Auto 27 -- Free Cooling Switch (Optional) 27 -- Unit Status Lights 27 --- Chilled Water Flow 27 --- Cooling Required 27 --- Running 27 --- Loading 27 --- Unloading 27 --- Manual Reset Required 27 --- Remote Chilled Water Setpoint 27 --- Remote Current Limit Setpoint 28 -- Display 32 Service Interface 32 -- Clear Restart Inhibit Push-Button 33 -- Control Response Setpoint 33 -- Start Differential Setpoint 	<ul style="list-style-type: none"> 33 -- Condenser Limit (% HPC; Optional) 33 -- Evaporator Refrigerant Trip Setpoint 34 Electrical Sequence of Operation 34 Overview 34 Fuse 1F2 Branch Circuit 34 -- Chilled and Condenser Water Flow Interlock Circuits 34 -- Micro Module and Wye-Delta Starter Control Circuits 40 Fuse 1F3 Branch Circuit 40 -- Oil Pump Circuit 40 -- Vane Actuator Circuit 41 Fuse 1F4 Branch Circuit (Purge Compressor) 41 -- Manual Purge Mode 41 -- Auto 42 Refrigerant Handling for Maintenance and Service 42 Introduction 42 Purge Tank Water Removal 42 Draining Rupture Disc Vent Line 42 Chiller Lubrication System 42 -- Compressor Oil Change 43 -- Replacing Oil Filter 43 Purge Service 43 Opening Chiller for Service 44 Refrigerant Recycle/Recovery Connections 44 Leak Testing 44 Refrigerant Charging 45 Model CVHE/CVHB/CVHF Checksheet and Request for Serviceman.
---	--	---

Notice

The Trane Company urges that all HVAC servicers working on Trane equipment, or any manufacturer's products, make every effort to eliminate, if possible, or vigorously reduce the emission of CFC, HCFC and HFC refrigerants to the atmosphere resulting from installation, operation, routine maintenance, or major service on this equipment.

Always act in a responsible manner to conserve refrigerants for continued use even when acceptable alternatives are available. Conservation and emission-reduction can be accomplished by following recommended Trane service and safety procedures published in Trane General Service Bulletins CTV-SB-81 and CTV-SB-82 and in Trane publication CFC-GUIDE-2 "Refrigerant Handling Guidelines". Copies of this literature may be obtained by contacting your local Trane commercial product representative.

General Information

Literature Change History

CTV-SUPL-1 (January 1991)

Original issue of manual describes additions and changes to the present IOM Literature for CVHE 50 Hz and 60 Hz units, design sequence "1C", and CVHB units design sequence "1D", or later.

CTV-SUPL-1A (May 1992)

Manual revised to provide:

- Initial data for Trane Model CVHF 1270 centrifugal chiller, "A" design sequence;
- Updated supplemental information for CVHE and CVHB units due to ongoing product improvement efforts and to availability of new information relative to refrigerant application and handling practices.

Refrigerant Requirements

The Trane Model CVHB, CVHE and CVHF centrifugal chillers covered by this manual utilize refrigerant CFC-11 or the environmentally-safe refrigerant HCFC-123. Prior to handling either refrigerant, consult the refrigerant manufacturer's Material Safety Data Sheets (MSDS) and Trane publication "CFC-GUIDE-2" for recommended safe handling practices.

About this Manual

This booklet provides new information and changes for the present CVHE and CVHB IOM literature that are the result of:

- Introduction of the model CVHF 1270 centrifugal chiller;
- Changes in UCM software;
- A change to provide an optional remote chiller On/Off function at the terminals previously used for an "external interlock" function; and, the ability to read refrigerant condensing temperature at the micro display;
- A change to provide the UCM "alarm relay package" as standard (previously an option);
- A vent-line timer change (timing change from 90 to 100 seconds);
- Introduction of improved Purifier Purge (new smart timer and availability of purge remote operating panel);
- Shipping modifications for Purifier Purge;
- Addition of factory-provided fittings to facilitate connection of Trane refrigerant recycle/recovery units;
- Revised recommendations for construction of rupture disc vent line;
- A change from flange-style evaporator and condenser water connections to grooved-pipe connections as standard.

This manual updates only those areas of the present CVHE/B IOM manuals that are affected by these changes.

Installation

Note: All installation procedures and data for CVHF 1270 units are identical to that provided for CVHE 1250 units unless otherwise noted.

Unit Weights

The Model CVHF 1270 weighs approximately 1450 pounds less than the Model CVHE 1250 unit. (Refer to the unit weight data provided in the CVHE installation literature.) Weights of unit options (i.e., auxiliary condenser, heat recovery condenser, etc.) do not change.

Purifier Purge Requirements

Purge Installation

For certain, later-design CenTraVacs, the purge system is not mounted on the chiller when it ships. For 800-ton heat recovery chillers and for 1,250- and 1,400-ton chillers with auxiliary condensers, the Purifier Purge is shipped in a separate container that is secured to the chiller shipping skid. During chiller installation, the purge system must be installed on the chiller according to the instructions provided with the purge.

Purge Water Connections

Since the Purifier Purge utilizes an air-cooled condensing system, no water connections are required.

Drier Core Installation

The Purifier Purge tank drier-core elements and three paper gaskets are shipped in sealed containers to prevent moisture contamination.

Caution: To prevent moisture contamination of the drier-core elements, do not remove them from their packaging until they can be installed and sealed in the purge tank.

Before the purge can be operated, the two drier-core elements must be installed in the purge tank as follows:

1. Remove purge tank body from its' base.
2. Install one of the paper gaskets provided on the tank base.
3. Install lower drier-core element on the base (over the gasket).
4. Place a second paper gasket on top of the lower drier-core element.
5. Install the upper drier-core element on top of the lower element (on the second gasket).
6. Place the last gasket on top of the upper element.
7. Place the spring-loaded copper cap on top of the upper element and replace and secure the purge tank body on its' base. Torque purge tank mounting bolts to 8 ft./lbs.

Caution: To prevent excessive surface wear of the drier-core elements, be certain to install paper gaskets correctly.

Caution: Drier-core elements must be installed in purge tank for proper system operation.

Purge Set-Up DIP Switch

The CenTraVac UCM will control either the previous-design, belt-driven purge unit or the Purifier Purge system. The UCM is configured at the factory to support the appropriate purge system at DIP switch No. 1 on switchblock S9 of the UCM. See "Chiller Control System" for DIP switch location.

Refrigerant Vent-Line Piping

General Recommendations

Both the purge and rupture disc vent lines must be routed to outside atmosphere. Use only material compatible with the refrigerant in use. The use of PVC (not CPVC) piping is acceptable if the pipe joint is properly primed and if the adhesive used has been tested for refrigerant compatibility. Testing conducted in Trane laboratories has approved the use of the following materials for PVC pipe construction:

Primer - Hercules, Primer for PVC, #60-456;

Adhesive - Hercules, Clear PVC, Medium Body, Medium Set, #60-020.

Figure 1
Typical Rupture Disc/Purge Discharge Vent Line Configuration

Consult with the manufacturers of any field-provided components or materials added to the refrigerant-side of the machine for acceptable material compatibility.

Purge Discharge Vent Line

On later-model CVHE/B units and on all CVHF units, the purge discharge is factory-piped into the rupture disc outlet on the unit. For earlier CVHE/B models, a 3/8-inch purge discharge vent line should be routed from the 3/8" MFL connection at the purge pumpout compressor and connected just downstream of the rupture disc (Figure 1).

Rupture Disc Vent Line

Any CenTraVac installation must utilize a properly-sized, flexibly-connected vent line for the rupture disc to the outdoor atmosphere. Sizing information is provided in the chiller installation manual.

The flexible connector used to isolate the rupture disc from excessive vent line vibration must be compatible with the refrigerant in use. Use a flexible, steel connector such as the stainless-steel type MFP, style HNE, flexible pump connector (from Vibration Mounting and Control, Inc.) or equivalent (Figure 1).

During vent line construction, provide a drip leg on the line that is of sufficient length to accommodate a minimum of one gallon of liquid. Provide a standard 1/4" FL x 1/4" NPT, capped refrigerant service valve to facilitate liquid removal. Accumulated liquid must be drained from the drip leg into an evacuated waste container once every six months, at a minimum; and more often if the purge operates excessively. Refer to "Maintenance Procedures" in this manual.

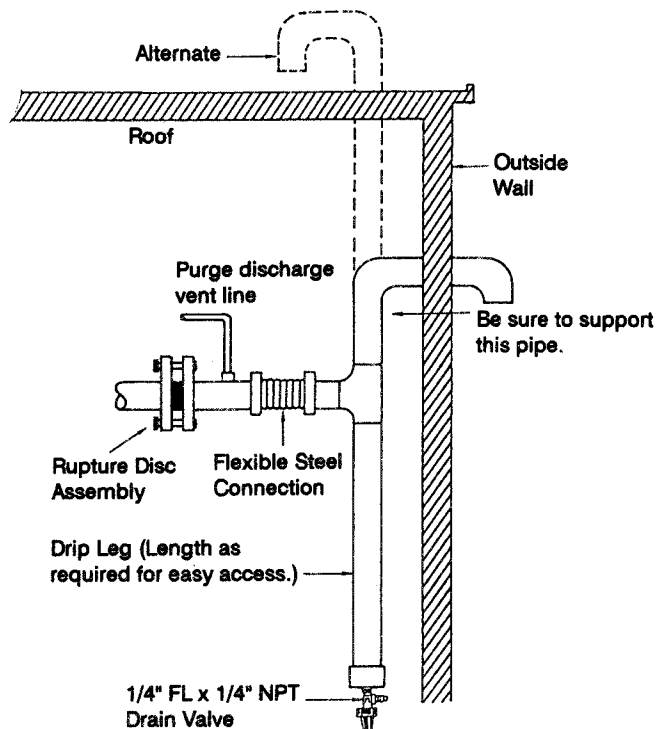

Water Piping Connections

For CVHEs of design sequences "A" thru "1C", condenser and evaporator water boxes utilize flat-faced, flange-type water piping connections. Beginning with design sequence "1D", however, all units (except those with 020 thru 050 condenser shells with 150 psig non-marine water boxes) use cut-groove end NPS (Victaulic®-style) pipe connections. All CVHF units, "A" and later design sequences, use grooved-pipe connections, also.

CVHB units are available with either flat-faced flanged or with grooved-pipe connections. Any grooved-pipe to flange adapter required for CVHBs must be customer-provided. See Table 1.

Piping joined using grooved type couplings, like all types of piping systems, requires proper support to carry the weight of pipes and equipment. The support methods used must eliminate undue stresses on joints, piping and other components; allow movement where required, and provide for any other special requirements (i.e., drainage, etc.).

Table 1
Water Piping Connection Components for CenTraVacs

Unit Model	Connection Type	Victaulic-To-Flange Adapter	Victaulic-To-Victaulic Pipe Coupling
CVHB	Flanged or Victaulic*	Customer-Provided	Customer-Provided
CVHE or CVHF	Flanged (Condenser 020-050 w/Non-Marine Water Box Only)	Trane-Provided	Customer-Provided
	Victaulic (All Others)	Trane-Provided	Customer-Provided

*Victaulic® is a registered trademark of Victaulic Company of America

Figure 2
Typical CVHE Grooved Pipe Connection

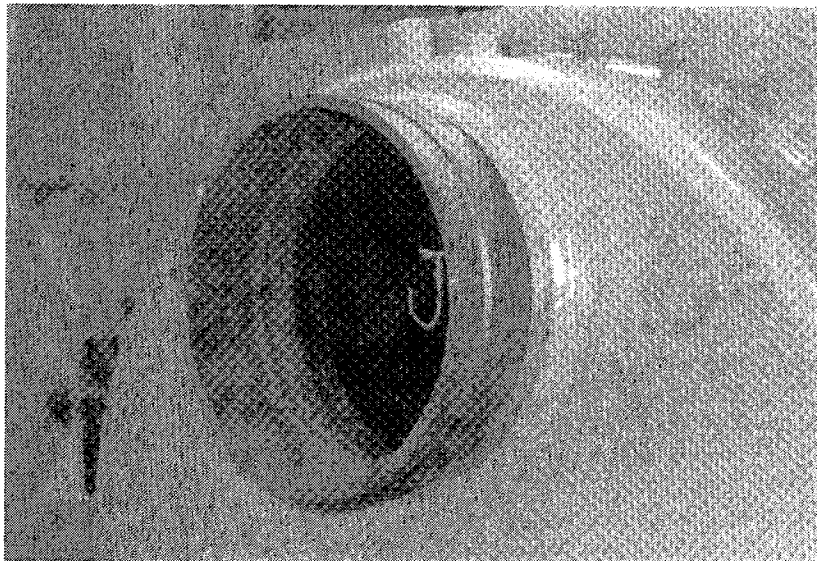

Grooved-Pipe Coupling

A customer-supplied, standard flexible grooved pipe coupling (Victaulic® Style 77 or equivalent) should be used to complete the Victaulic connection for both 150 and 300 psig water boxes. See Table 1. When a flexible coupling such as this is installed at the waterbox connections (Figure 3), other flexible piping connectors (i.e., braided-steel, elastomeric arch, etc.) are usually not required to attenuate vibration and/or prevent stress on the connections.

Refer to the coupling manufacturer's guidelines for specific information concerning proper piping system design and construction methods for grooved water piping systems.

Note: Flexible coupling gaskets require proper lubrication before installation to provide a good seal. Refer to the coupling manufacturer's guidelines for proper lubricant type and application.

Figure 3
Customer Piping Alternatives for CVHE/F Water Connections

Customer Piping Connection Type	Trane Water Box Construction	
	Cast Flange; 150# Non-Marine (CVHE/F W/020-050 Condenser)	Fabricated (All Others)
Flanged		
Victaulic®		

Flange-Connection Adapters

When flat-face flange connections are specified, flange-to-groove adapters are provided (Victaulic® Style 741 for 150 psig systems; Style 743 for 300 psig systems). The adapters are shipped bolted to one of the chiller end-supports (Figure 4). Adapter weights are given in Tables 2 and 3. The flange adapters provide a direct, rigid connection of flanged components to the grooved-pipe chiller waterbox connections.

In this case, the use of flexible type connectors (i.e., braided steel, elastomeric arch, etc.) **is** recommended to attenuate vibration and/or prevent stress at the water-box connections. Flange adapters are not provided for any CVHB units, or for CVHE units with 300 psig water boxes that have 14-inch or 16-inch piping connections.

All flange-to-flange assembly bolts must be provided by the installer. Bolt sizes and number required are given in Tables 1 and 2. The four draw-bolts needed for the 14-inch and 16-inch Style 741 (150 psig) adapters are provided. The Style 741, 150 psig flange adapter requires a smooth, hard surface for a good seal.

Connection to other type flange faces (i.e., raised, serrated, rubber, etc.) will require the use of a flange washer between the faces. Refer to the flange adapter manufacturer's guidelines for specific information.

The Style 743, 300-psig flange adapters are designed to mate with raised-face flanges. They can be used with flat-faced flanges, however, if the raised projections on the outside face of the adapter are removed (Figure 5).

Note: The flange-adapter gasket must be placed with the color-coded lip on the pipe and the other lip facing the mating flange.

Caution: To provide effective seal, gasket-contact surfaces of adapter must be free of gouges, undulations or deformities.

Figure 4
Typical Shipping Location for Victaulic®
Flange Connection Adapters

Flange Adapters
Bolted in Shipping
Position

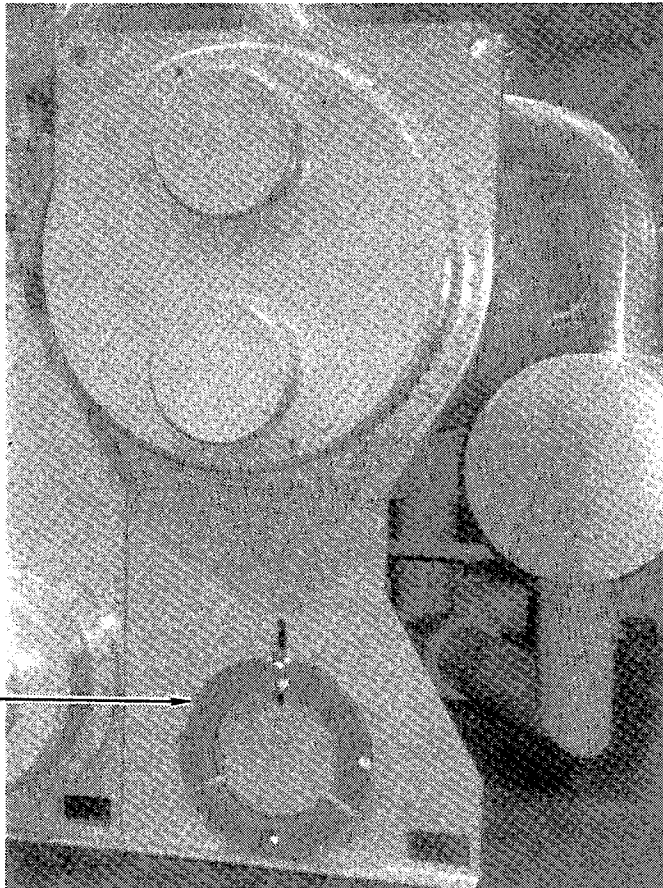

Table 2
Installation Data for CVHE/CVHF 150 PSIG Flange Adapters

Note: Flange adapters not provided when Victaulic® connections specified for CVHB units.

Nom. Size (In./mm)	Ass'y Bolt Size (In.)*	No. Ass'y Bolts Req.	Bolt Pattern Dia. (In./mm)	Weight (Lbs./kg)
4/100	5/8 x 3	8	7.5/191	7.7/3.5
5/125	3/4 x 3-1/2	8	8.5/216	9.3/4.2
6/150	3/4 x 3-1/2	8	9.5/241	10.3/4.7
8/200	3/4 x 3-1/2	8	11.75/298	16.6/7.5
10/250	7/8 x 1/4	12	14.25/362	24.2/11.0
12/300	7/8 x 1/4	12	17.0/432	46.8/21.2
14/350	1 x 4-1/2	12	18.75/476	75.0/34.0
16/400	1 x 4-1/2	16	21.25/540	90.0/40.8

* Bolt size for conventional flange-to-flange connection. Longer bolts are required when flange washer must be used.

Table 3
Installation Data for CVHE/CVHF 300 PSIG Flange Adapters

Nom. Size (In./mm)	Ass'y Bolt Size (In.)*	No. Ass'y Bolts Req.	Bolt Pattern Dia. (In./mm)	Weight (Lbs./kg)
4/100	3/4 x 3-3/4	8	7.88/200	15.3/6.9
5/125	3/4 x 4	8	9.25/235	17.7/8.0
6/150	3/4 x 4-1/2	12	10.63/270	23.4/10.6
8/200	3/4 x 4-3/4	12	13.0/330	34.3/15.6
10/250	1 x 5-1/4	16	15.25/387	48.3/21.90
12/300	1-1/8 x 5-3/4	16	17.75/451	70.5/32.0

* Bolt size for conventional flange-to-flange connection. Longer bolts are required when flange washer must be used.

Figure 5
Modifying CVHE/CVHF 300 PSIG Flange Adapters for Flat-Faced Flange Application

Note: Mating face of shaded areas must be free of gouges, nicks undulations or deformities of any type for effective sealing.

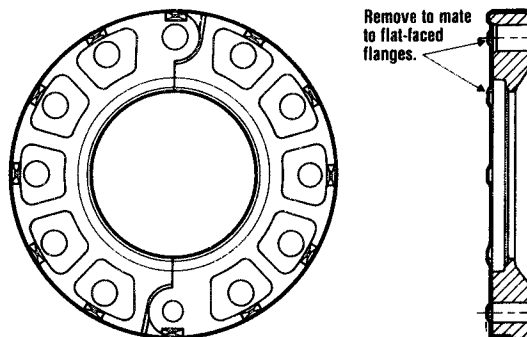

Electrical Wiring

Field wiring procedures for CVHF units, CVHE units of "1C" design sequence and later and for CVHB units of "1D" design sequence and later are identical to that of previous units, with these two exceptions:

1. Remote On/Off Control

The "external interlock" function (previously used to indicate a system fault from a remote customer provided device) is no longer provided at terminals 1TB3-16 and -17 in the UCP. These terminals are now designated as the connection points for an "external inhibit" input. This will provide a chiller On/Off function from a customer-provided remote controller. Refer to Figures 6, 7, and 8 on pages 12-17.

As long as these "external inhibit" contacts remain open, the unit is OFF and the UCM will display code **A 100**, indicating external inhibit function is energized. When these contacts close, unit operation resumes automatically... provided that all other start criteria are met.

Note: To use this method of remote chiller control, the chiller switch on the UCP must be set at the AUTO position.

WIRING PROCEDURE:

To start and stop the unit from a remote (customer-provided) control, first remove the jumper from between terminals 1TB3-16 and -17 in the UCP. Then connect a set of normally-open contacts to these terminals (Figures 6, 7, and 8). Placement of these contacts in the "external inhibit" circuit assures that the unit cannot run unless directed to do so by the remote controller.

Note: A jumper is factory-installed between the external inhibit terminals (1TB3-16 and -17). If the external inhibit function is not utilized, these terminals must remain shorted for the unit to operate.

Important! Do not attempt to use the "running external interlock" for chiller remote On/Off control. These inputs will shut the unit down on a latching diagnostic. Then the unit cannot be restarted until the UCM is reset manually at the UCP.

Previously, it was necessary to connect any remote On/Off device between the auxilliary contacts of evaporator water pump contactor 5K1 and terminal 1TB5-17 in the UCP. This is no longer required.

2. Remote Purge Fault Indicator (Purifier Purge Only)

To provide a remote indication of a purge fault (excessive purging), connect the remote indicator to be used at terminals 3TB1-7 and -8 in the purge control panel as shown in Figures 6, 7, and 8 on pages 12-17. This terminal strip is located in the UCP-mounted (remote) purge control panel on all CVHE and CVHF units over 560 tons equipped with free-cooling or auxilliary condenser; and, on the CVHB 1550. Otherwise, it is found on the purge panel mounted on the purge-unit platform.

Alarm Relay Package

On all units manufactured after January 1991, the alarm relay package is provided as standard on all units. These two relay output circuits were previously provided on an optional basis only. See Figures 6, 7 and 8 on pages 12-17.

Unit Start-Up

All phases of initial unit start-up must be conducted under the supervision of a qualified local service engineer. This includes pressure testing, evacuation, electrical checks, refrigerant charging, actual start-up, and operator instruction.

Complete the "CenTraVac Check Sheet and Request for Service-man" form found at the end of this manual, and forward it to your local Trane Service Company. Advance notification is required to assure that initial start-up is scheduled as close to the requested date as possible.

Power Factor Correction Capacitors

PFCC voltage data for CVHB, CVHE and CVHF units is given in Table 4 below. Proper PFCC selections for design-rated voltages are shown in the CenTraVac price sheet motor data tables.

IMPORTANT!

The information required to select proper PFCCs for other than design rated voltages is:

- Motor Voltage;
- Motor Hertz;
- Motor Required Capacitance Correction (KVAR);
- PFCC Design Voltage;
- PFCC Design Hertz;
- PFCC Sizes available;

Using this information, calculate required PFCC rating as follows:

$$\text{PFCC KVAR} = \text{Required Correction} \left(\frac{\text{PFCC Design Voltage}}{\text{Motor Voltage}} \right)^2 \cdot \left(\frac{\text{PFCC Design Hz.}}{\text{Motor Hz.}} \right)$$

Example: Motor Volts = 380V; Motor Hz = 50 Hz.; Required correction = 72 KVAR; PFCC Design Volts = 480V; PFCC Design Hz = 60 Hz.

$$\text{PFCC KVAR} = 72 \left(\frac{480}{380} \right)^2 \cdot \left(\frac{60}{50} \right) = 137.8$$

Use PFCC with rating closest to but below required PFCC rating, which in this case, could be a 125 KVAR/480V/60Hz. capacitor.

Table 4
PFCC Voltage Data per Compressor Voltage Application

Compressor Motor Voltage (Note)	PFCC Design Voltage
200/60 Hz.	240/60 Hz.
208/60 Hz.	
220/60 Hz.	
230/60 Hz.	
240/60 Hz.	
346/50 Hz.	346/50 Hz.
380/50 Hz.	380/50 Hz.
380/60 Hz.	480/60 Hz.
400/50 Hz.	415/50 Hz.
415/50 Hz.	
440/60 Hz.	480/60 Hz.
460/60 Hz.	
480/60 Hz.	
575/60 Hz.	600/60 Hz.
600/60 Hz.	
2300/60 Hz.	2400/60 Hz.
2400/60 Hz.	
330/50 Hz.	330/50 Hz.
3300/60 Hz.	4160/60 Hz.
4000/60 Hz.	
4160/60 Hz.	
4800/60 Hz.	Contact CenTraVac Marketing
6600/60 Hz.	
6000/50 Hz.	Contact CenTraVac Marketing
6600/50 Hz.	

Note: Refer to unit nameplate for compressor motor voltage.

Figure 6
Typical CVHE/F Field Wiring Layout and Sensor Locations

NOTES:

1. DASHED LINES INDICATE FIELD WIRING BY OTHERS. PHANTOM LINES INDICATE ALTERNATE CIRCUITRY OR AVAILABLE SALES OPTION. CHECK S.O. TO DETERMINE IF WIRING IS REQUIRED FOR SPECIFIC OPTIONS.
 2. ALL FIELD WIRING MUST BE IN ACCORDANCE WITH THE NATIONAL ELECTRIC CODE (NEC), STATE AND LOCAL REQUIREMENTS. OTHER COUNTRIES APPLICABLE NATIONAL AND/OR LOCAL REQUIREMENTS SHALL APPLY.
- ◁ 3 AUXILIARY CONTROLS FOR A CUSTOMER SPECIFIED OR INSTALLED LATCHING SAFETY TRIP-OUTS.
- ◁ 3A AUXILIARY TERMINAL CONNECTIONS FOR A CUSTOMER SPECIFIED OR INSTALLED OPERATING STATUS INPUT.
4. THE FOLLOWING CAPABILITIES ARE OPTIONAL- THEY ARE IMPLEMENTED AND WIRED AS REQUIRED FOR A SPECIFIC SYSTEM APPLICATION.
 - ◁ A CHILLED WATER RESET- REQUIRES MATCHED PAIR OF THERMISTORS FOR 4RT1 & 4RT2. IF AMBIENT TEMP BASED CHILLED WATER RESET IS REQUIRED, USE STD SUPPLIED LEAVING EVAP WATER TEMP SENSOR (4RT1) FOR 4RT2 AS AN AMBIENT TEMP SENSOR.
 - ◁ B RELAY PACKAGE- INCLUDES HEAD RELIEF REQUEST AND REMOTE ALARM CIRCUIT.
 - ◁ C ENTERING EVAP TEMP SENSOR- REQUIRES MATCHED PAIR OF THERMISTORS FOR 4RT1 & 4RT2.
 - ◁ D ENTERING AND LEAVING CONDENSER WATER TEMP SENSORS MATCHED PAIR OF THERMISTORS FOR 4RT3 & 4RT4.
 - ◁ E TRACER MONITORING PACKAGE (60HZ UNITS ONLY) INCLUDES OPTIONS C AND D PLUS THERMISTOR FOR 4RT6 TO BE USED AS CONDENSER REFRIGERANT TEMP SENSOR.
 5. FOR SENSOR DISCRPTION SEE B4533-1710.

WIRING REQUIREMENTS

DO NOT RUN LOW VOLTAGE WIRE (30 VOLTS MAX) IN CONDUIT OR RACEWAY WITH HIGHER VOLTAGE WIRE.

REQUIRED WIRING:

- ◁ 21 9 WIRES 2--#10 AWG 600V, 7--#14 AWG 600V
- ◁ 22 8 WIRES #14--#16 AWG 600V, RUN IS SEPARATE COUDUIT. USE #16 AWG UP TO 250 FT ONEWAY OR #14 AWG UP TO 400 FT ONEWAY
- ◁ 23 COPPER WIRE ONLY SIZED PER N.E.C. 1984 BASED ON NAMEPLATE RLA SEE TABLE 1
- ◁ 24 4 WIRES #14 AWG 600V, SEPARATE 115 VAC POWER IS REQUIRED TO STARTER
- ◁ 25 2 WIRES #14 AWG 600V
- ◁ 28 2 WIRES #14--#18 AWG 600V, DO NOT RUN IN CONDUIT WITH HIGHER VOLTAGE WIRE SEE TABLE 2

OPTIONAL WIRING

- ◁ 27 3 WIRES #14 AWG 600V, SEPARATE 115 VAC POWER SUPPLY IS REQUIRED
- ◁ 28 2 WIRES #14 AWG 600V, SEPARATE 115 VAC POWER SUPPLY IS REQUIRED
- ◁ 29 2 WIRES #14 AWG 600V
- ◁ 30 2 WIRES #14--#18 AWG 600V, DO NOT RUN IN CONDUIT WITH HIGHER VOLTAGE WIRE SEE TABLE 2
- ◁ 31 SHIELDED TWISTED PAIR. 30V OR LESS #14--#18 AWG 600V. MAX LENGTH 5000FT. DO NOT RUN IN CONDUIT WITH HIGHER VOLTAGE WIRE.
- ◁ 32 IF UNIT IS SUPPLIED WITH UNIT MOUNTED STARTER, FIELD WIRING BETWEEN UNIT AND STARTER IS NOT REQUIRED.

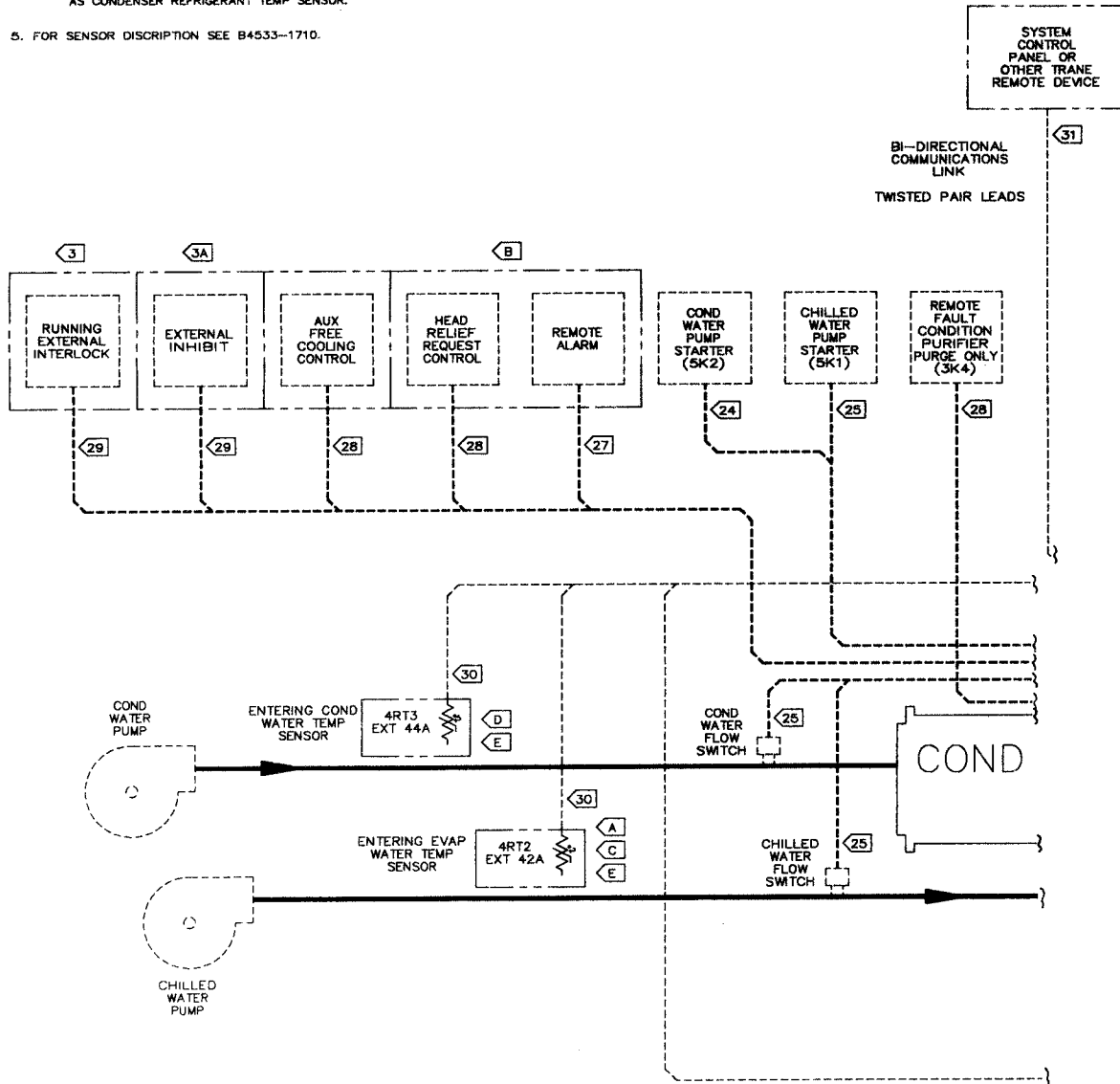

(Continued on next page)

(Continued from previous page)

TABLE 1
RECOMMENDED WIRE SELECTION TABLE (REF. NEC 1984)
RATED LOAD CURRENT (NAMEPLATE)

MIN. WIRE SIZE COPPER 75° C	SUPPLY LEADS OR MOTOR LEADS FOR ACROSS-THE LINE, AUTO-TRANS STARTER OR PRIMARY REACTOR STARTER						MOTOR LEADS FOR STAR DELTA STARTER		
	1 CONDUIT 3 WIRES		2 CONDUITS 3 WIRES EA		1 CONDUIT 6 WIRES		2 CONDUITS 3 WIRES EA		1 CONDUIT 6 WIRES
	8	6	4	3	2	1	8	6	4
8	40		N/A				69.2		55.4
6	52						90.0		72.0
4	68						117.6		94.1
3	80						138.4		110.7
2	92						159.2		127.3
1	104						179.9		143.9
0	120	240		192.0			207.6		166.1
00	140	280		224.0			242.2		193.8
000	160	320		256.0			276.8		221.4
0000	184	368		294.4			318.3		254.7
250	204	408		328.4			352.9		282.3
300	228	456		384.8			394.4		315.6
350	248	496		396.8			429.0		343.2
400	268	538		428.8			463.6		370.9
500	304	608		486.4			525.9		420.7
600	336	672		537.6			581.3		465.0

TABLE 2

WIRE WIZE	MAX LENGTH FOR SENSOR LEADS
14 AWG	5000 FT
16 AWG	2000 FT
18 AWG	1000 FT

WARNING

DISCONNECT ELECTRIC POWER SUPPLY BEFORE SERVICING TO PREVENT INJURY OR DEATH DUE TO ELECTRICAL SHOCK.

AVERTISSEMENT

DEBRANCHER DU CIRCUIT D'ALIMENTATION ELECTRIQUE AVANT L'ENTRETIEN POUR EVITER BLESSURE OU MORT PAR ELECTROCUTION.

CAUTION

USE COPPER CONDUCTORS ONLY TO PREVENT EQUIPMENT DAMAGE. UNIT TERMINALS ARE NOT DESIGNED TO ACCEPT ANY OTHER WIRING.

ATTENTION

UTILISER SEULEMENT DES CONDUCTEURS EN CUIVRE POUR EVITER D'ENDOMMAGER L'EQUIPEMENT. LES BORNES NE SONT PAS PREVUES POUR AUTRES TYPES DE FILS CONDUCTEURS.

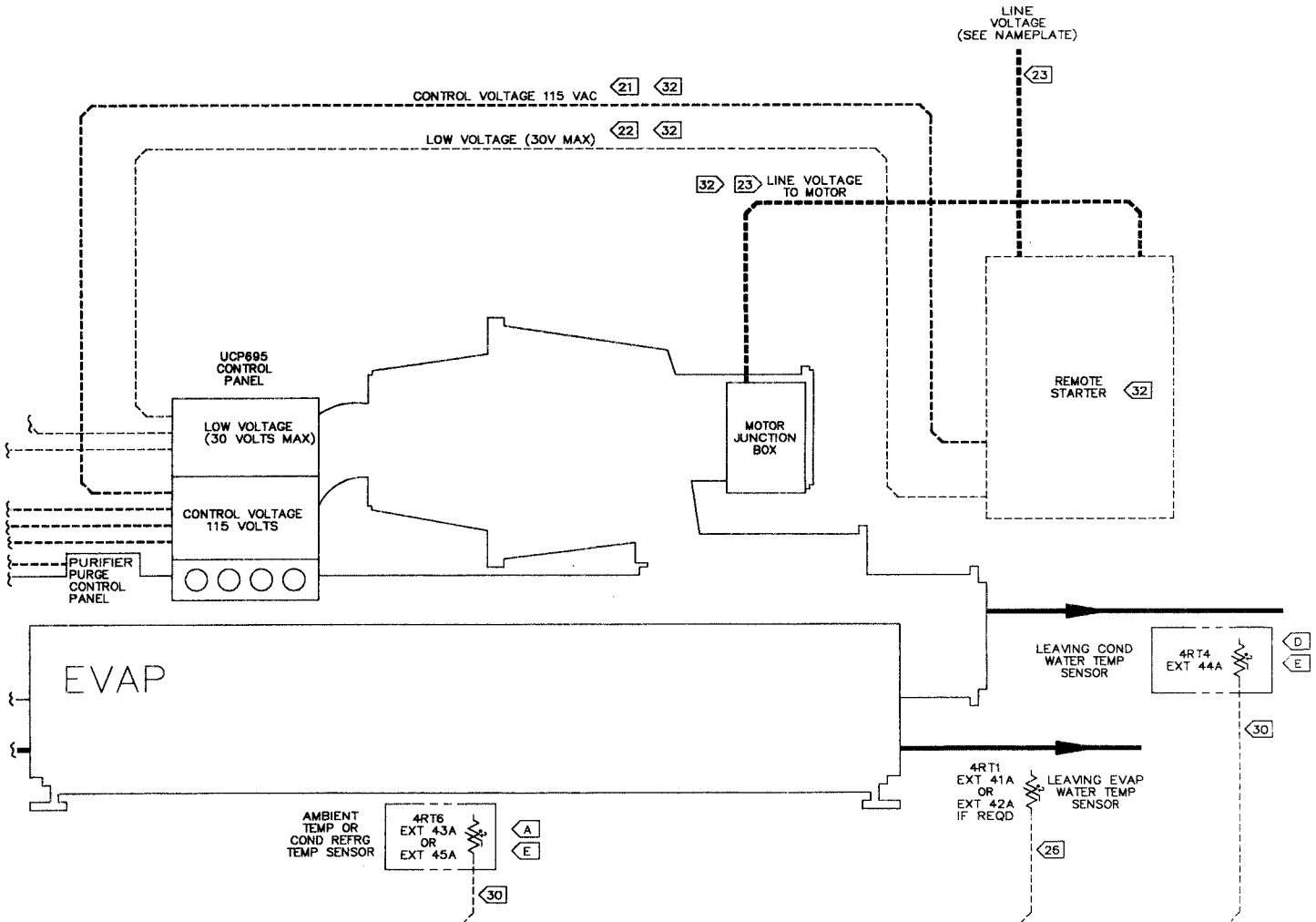
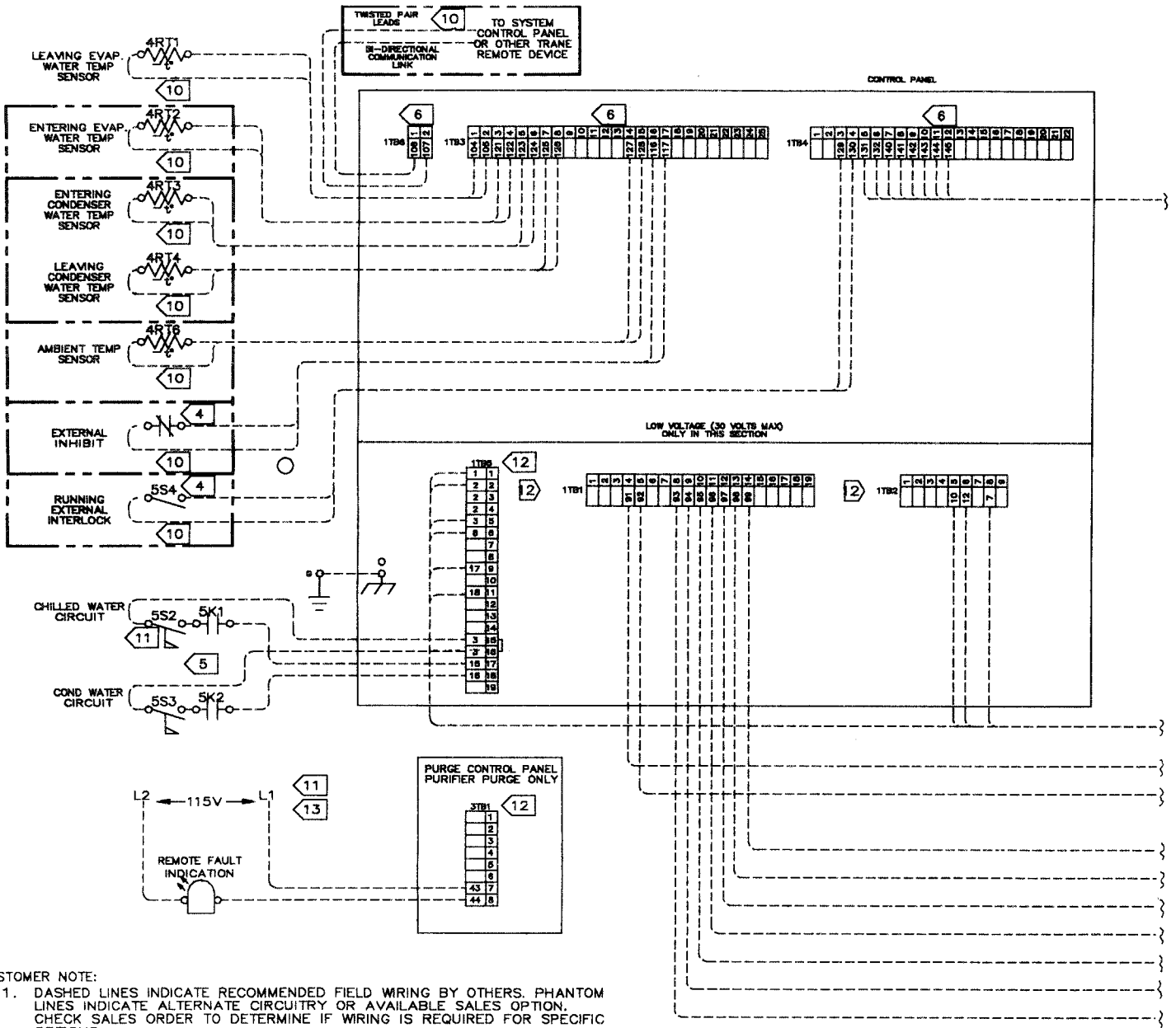

Figure 7
Typical Field Wiring Connections for CVHB/CVHE/CVHF w/Remote Starter



CUSTOMER NOTE:

1. DASHED LINES INDICATE RECOMMENDED FIELD WIRING BY OTHERS. PHANTOM LINES INDICATE ALTERNATE CIRCUITRY OR AVAILABLE SALES OPTION. CHECK SALES ORDER TO DETERMINE IF WIRING IS REQUIRED FOR SPECIFIC OPTIONS.
 2. ALL FIELD WIRING MUST BE IN ACCORDANCE WITH THE NATIONAL ELECTRICAL CODE (NEC), STATE AND LOCAL REQUIREMENTS. OTHER COUNTRIES APPLICABLE NATIONAL AND/OR LOCAL REQUIREMENTS SHALL APPLY.
- 3 CONTROL VOLTAGE WIRING (115 VAC) TERMINALS 1 THRU 9 AND LOW VOLTAGE WIRING (30 VOLTS MAX) TERMINALS 10 THRU 17 MUST BE KEPT SEPERATE BOTH INSIDE OF STARTER AND IN RUNS TO CONTROL PANEL
 - 4 CUSTOMER SUPPLIED CONTACTS MUST BE COMPATIBLE WITH DRY CIRCUIT 12 VDC, 45 mA. GOLD PLATED CONTACTS RECOMMENDED.
 - 5 RECOMMENDED CIRCUIT; COMPONENTS SUPPLIED BY OTHERS, 5K1 & 5K2 ARE AUX CONTACTS ON PUMP STARTERS; 5S2 & 5S3 ARE FLOW SWITCHES IN APPROPRIATE WATER CIRCUITS; SIZED TO CONTROL A LOAD RATED 115 VAC, 19 VA.
 - 6 RETIGHTEN TERMINALS A MINIMUM OF 24 HOURS AFTER INITAL INSTALLATION. DO NOT OVER TIGHTEN.
 - 7 BUS BARS NOT INCLUDED - MUST BE ORDERED SEPARATELY.
 - 8 COPPER WIRE, SIZED PER N.E.C., BASED ON UNIT NAMEPLATE RLA PLUS TRANSFORMER LOAD IN L1 & L2. PHASING OF 3 PHASE INPUT: L1 TO A, L2 TO B, L3 TO C WHERE ABC REPRESENTS STANDARD PHASE ROTATION.
 - 9 COPPER WIRE ONLY, SIZED PER N.E.C., BASED ON NAMEPLATE RLA.
 - 10 30V OR LESS #14-18 AWG 600V WIRE. DO NOT RUN IN CONDUIT WITH HIGHER VOLTAGE WIRE.
 - 11 115V AC. #14 AWG 600V WIRE, MAX FUSE SIZE 15A.

12 FIELD WIRED ELECTRICAL LOADING IS NOT TO EXCEED THE FOLLOWING RATINGS:

TERMINALS	DEVICE	RATED VOLTAGE (VAC)	RATED V/A
1TB1-4,5	1U1K6	120	240
1TB1-8,10	1U1K4-2	120	240
1TB1-9,10	1U1K4-1	120	240
1TB1-11,12	1U1K3	120	240
1TB1-13,14	1U2K2	120	120
1TB2-5,6	1U2K5	120	240
1TB5-6	1U2K4	120	120
1TB2-8	1U2K1,2,3	120	120
3TB1-7,8	3K4	120	240

13 FOR CANADIAN INSTALLATION (CSA) ONLY. LOCAL INSPECTION AUTHORITIES MAY REQUIRE SINGLE POWER SOURCE DISCONNECTING MEANS.

(Continued on next page)

(Continued from previous page)

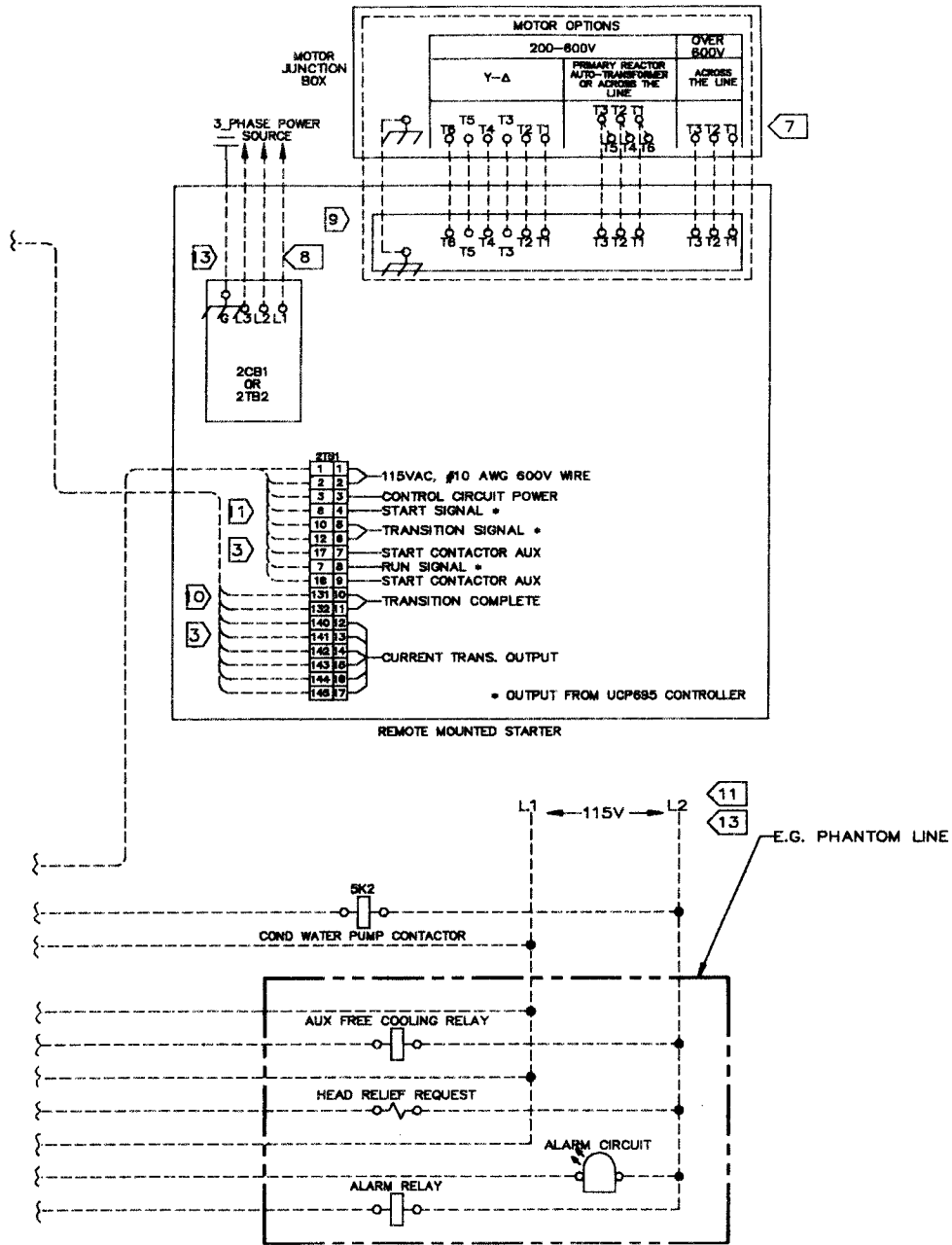

<p>⚠ WARNING</p> <p>DISCONNECT ELECTRIC POWER SUPPLY BEFORE SERVICING TO PREVENT INJURY OR DEATH DUE TO ELECTRICAL SHOCK.</p> <p>AVERTISSEMENT</p> <p>DEBRANCHER DU CIRCUIT D'ALIMENTATION ELECTRIQUE AVANT L'ENTRETIEN POUR EVITER BLESSURE OU MORT PAR ELECTROCUTION.</p>	<p>⚠ CAUTION</p> <p>USE COPPER CONDUCTORS ONLY TO PREVENT EQUIPMENT DAMAGE. UNIT TERMINALS ARE NOT DESIGNED TO ACCEPT ANY OTHER WIRING.</p> <p>ATTENTION</p> <p>UTILISER SEULEMENT DES CONDUCTEURS EN CUIVRE POUR EVITER D'ENDOMMAGER L'EQUIPMENT. LES BORNES NE SONT PAS PREVUES POUR AUTRES TYPES DE FILS CONDUCTEURS.</p>
---	--

Figure 8
Typical Field Wiring Connections for CVHE/CVHF w/Unit-Mounted Starter

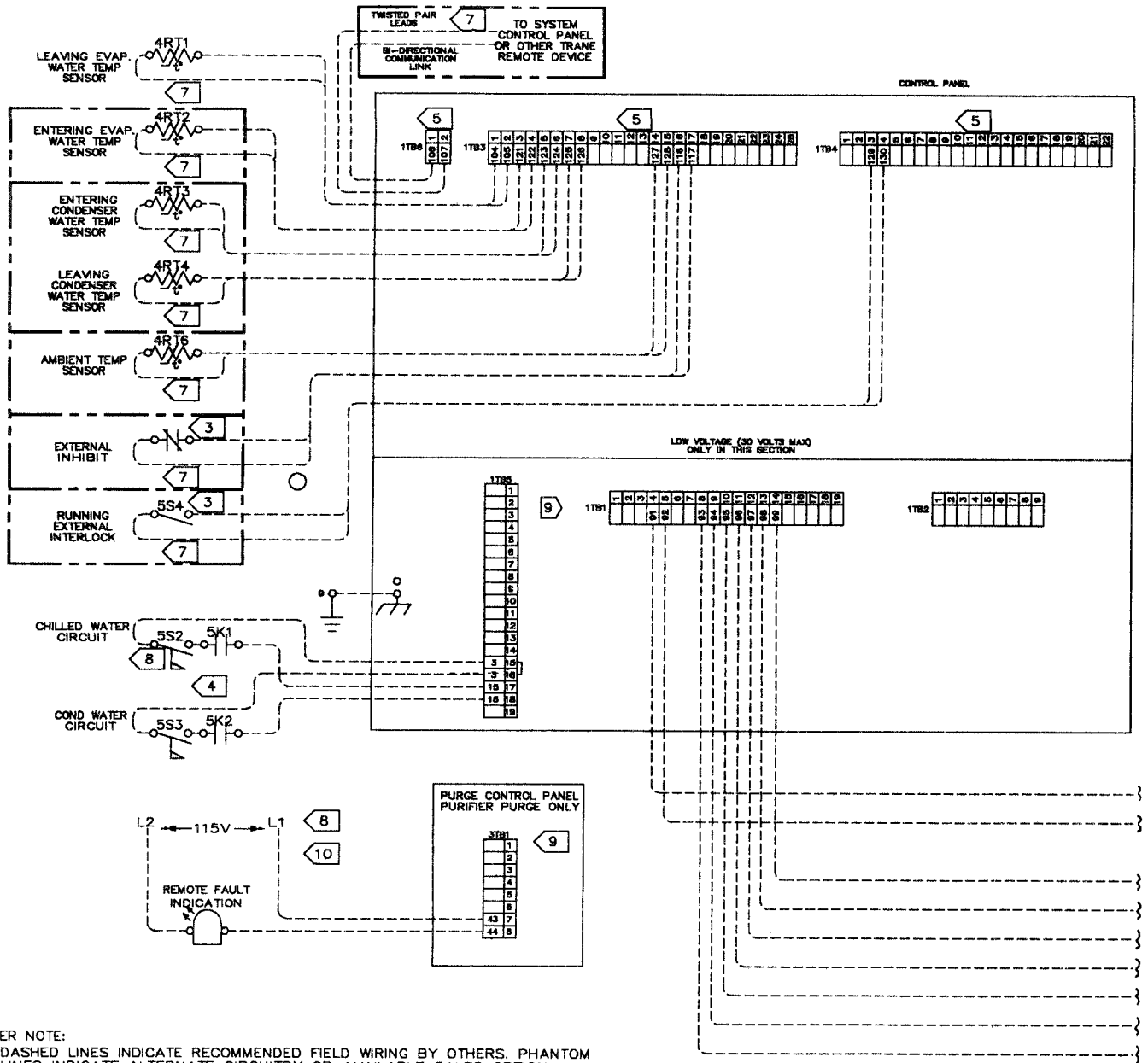

CUSTOMER NOTE:

1. DASHED LINES INDICATE RECOMMENDED FIELD WIRING BY OTHERS. PHANTOM LINES INDICATE ALTERNATE CIRCUITRY OR AVAILABLE SALES OPTION. CHECK SALES ORDER TO DETERMINE IF WIRING IS REQUIRED FOR SPECIFIC OPTIONS.
 2. ALL FIELD WIRING MUST BE IN ACCORDANCE WITH THE NATIONAL ELECTRICAL CODE (NEC), STATE AND LOCAL REQUIREMENTS. OTHER COUNTRIES APPLICABLE NATIONAL AND/OR LOCAL REQUIREMENTS SHALL APPLY.
- 3. CUSTOMER SUPPLIED CONTACTS MUST BE COMPATIBLE WITH DRY CIRCUIT 12 VDC, 45 mA. GOLD PLATED CONTACTS RECOMMENDED.
 - 4. RECOMMENDED CIRCUIT; COMPONENTS SUPPLIED BY OTHERS, 5K1 & 5K2 ARE AUX CONTACTS ON PUMP STARTERS; 5S2 & 5S3 ARE FLOW SWITCHES IN APPROPRIATE WATER CIRCUITS; SIZED TO CONTROL A LOAD RATED 115 VAC, 19 VA.
 - 5. RETIGHTEN TERMINALS A MINIMUM OF 24 HOURS AFTER INITIAL INSTALLATION. DO NOT OVER TIGHTEN.
 - 6. COPPER WIRE, SIZED PER N.E.C., BASED ON UNIT NAMEPLATE RLA PLUS TRANSFORMER LOAD IN L1 & L2. PHASING OF 3 PHASE INPUT: L1 TO A, L2 TO B, L3 TO C WHERE ABC REPRESENTS STANDARD PHASE ROTATION.
 - 7. 30V OR LESS #14-18 AWG 600V WIRE. DO NOT RUN IN CONDUIT WITH HIGHER VOLTAGE WIRE.

(Continued on next page)

(Continued from previous page)

CAUTION
 USE COPPER CONDUCTORS ONLY TO PREVENT EQUIPMENT DAMAGE. UNIT TERMINALS ARE NOT DESIGNED TO ACCEPT ANY OTHER WIRING.

ATTENTION
 UTILISER SEULEMENT DES CONDUCTEURS EN CUIVRE POUR EVITER D'ENDOMMAGER L'EQUIPMENT. LES BORNES NE SONT PAS PREVUES POUR AUTRES TYPES DE FILS CONDUCTEURS.

WARNING
 DISCONNECT ELECTRIC POWER SUPPLY BEFORE SERVICING TO PREVENT INJURY OR DEATH DUE TO ELECTRICAL SHOCK.

AVERTISSEMENT
 DEBRANCHER DU CIRCUIT D'ALIMENTATION ELECTRIQUE AVANT L'ENTRETIEN POUR EVITER BLESSURE OU MORT PAR ELECTROCUTION.

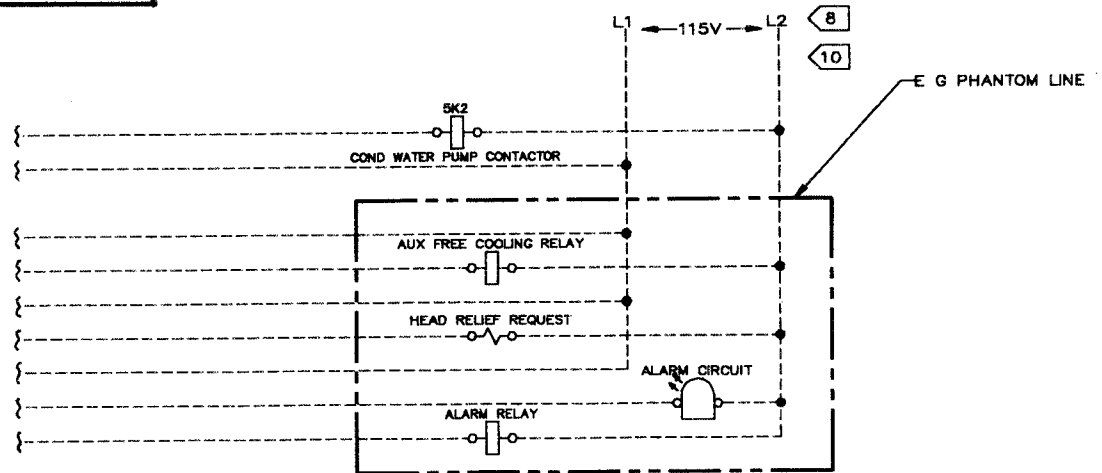
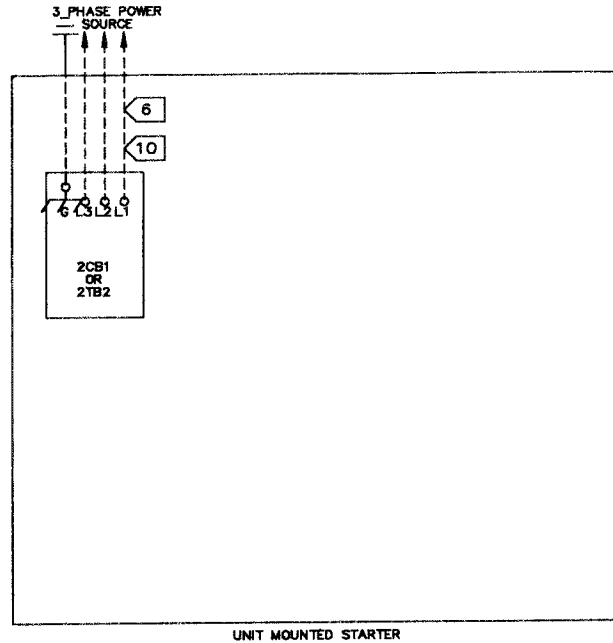

8 115V AC. #14 AWG 600V WIRE, MAX FUSE SIZE 15A.

9 FIELD WIRED ELECTRICAL LOADING IS NOT TO EXCEED THE FOLLOWING CONTACT RATINGS:

TERMINALS	DEVICE	RATED VOLTAGE (VAC)	RATED V/A
1TB1-4,5	1U1K6	120	240
1TB1-8,10	1U1K4-2	120	240
1TB1-9,10	1U1K4-1	120	240
1TB1-11,12	1U1K3	120	240
1TB1-13,14	1U2K2	120	120
3TB1-7,8	3K4	120	240

10 FOR CANADIAN INSTALLATION (CSA) ONLY. LOCAL INSPECTION AUTHORITIES MAY REQUIRE SINGLE POWER SOURCE DISCONNECTING MEANS.

Mechanical Operation - CVHF

Overview

The following description applies to the Trane Model CVHF centrifugal chiller only. Refer to the appropriate operation manual for refrigeration cycle descriptions of other models.

Each CVHF unit is comprised of 5 basic components:

- the evaporator;
- 2-stage compressor;
- water-cooled condenser;
- single-stage economizer, and;
- related interconnecting piping.

A heat-recovery or auxiliary condenser can be factory-added to the basic unit assembly to provide a heat-recovery cycle.

Figure 9 illustrates the general component layout of a typical CVHF chiller.

CVHF cooling-only and heat recovery modes of operation are described in the following sections. A pressure/enthalpy diagram (shown in Figure 10) is provided to further illustrate unit operation.

Cooling-Only Cycle

When the CVHF is functioning in the cooling mode, liquid refrigerant is distributed along the length of the evaporator and sprayed through small holes in a distributor (i.e., running the entire length of the shell) to uniformly coat each evaporator tube. Here, the liquid refrigerant absorbs enough heat from the system water circulating through the evaporator tubes to vaporize.

The gaseous refrigerant is then drawn through the eliminators (which remove droplets of liquid refrigerant from the gas), first-stage variable inlet guide vanes, and into the first-stage impeller.

Note: Inlet guide vanes are designed to modulate the flow of gaseous refrigerant to meet system capacity requirements; they also prerotate the gas, allowing it to enter the impeller at an optimal angle that maximizes efficiency at all load conditions.

Compressed gas from the first-stage impeller is discharged through the second-stage variable guide vanes and into the second-stage impeller. Here, the refrigerant gas is again compressed, and then discharged into the condenser.

Baffles within the condenser shell distribute the compressed refrigerant gas evenly across the condenser tube bundle. Cooling tower water, circulated through the condenser tubes, absorbs heat from the refrigerant, causing it to condense. The liquid refrigerant then flows out of the bottom of the condenser, passing through an orifice plate and into the economizer.

The economizer reduces the energy requirements of the refrigeration cycle by eliminating the need to pass all gaseous refrigerant through both stages of compression. See Figure 11. Notice that some of the liquid refrigerant flashes to a gas because of the pressure drop created by the orifice plate, thus further cooling the liquid refrigerant. This flash gas is then drawn directly from the economizer into the second-stage impellers of the compressor. The remaining liquid refrigerant flows out of the economizer, passes through another orifice plate and into the evaporator.

Free Cooling, Heat Recovery and Auxiliary Condenser Cycles

The operational description of these optional components is identical to that of the CVHE. Refer to the CVHE operation and maintenance manual.

Figure 9
General Component Identification – Trane CVHF 1270

End View

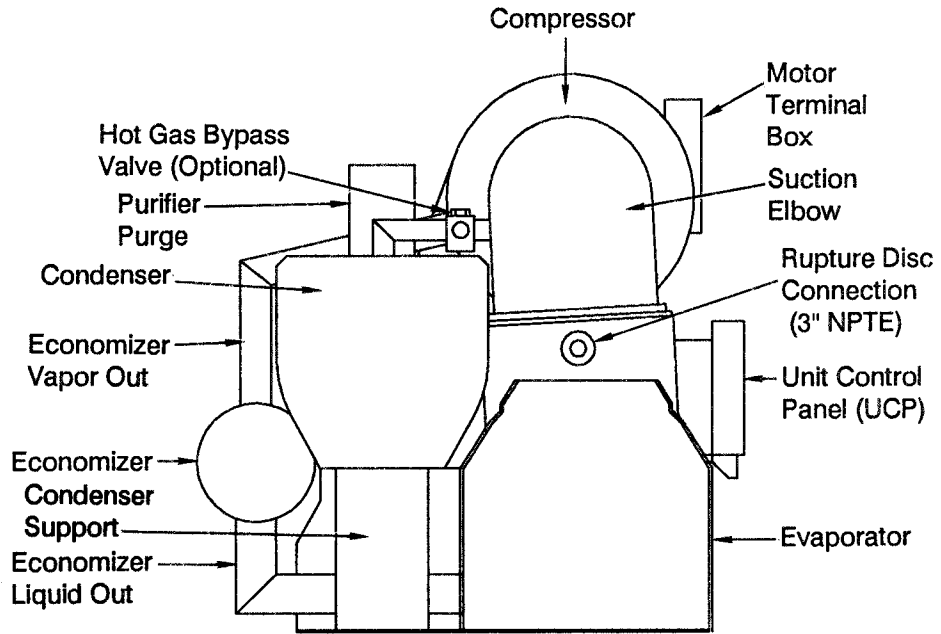

Front View

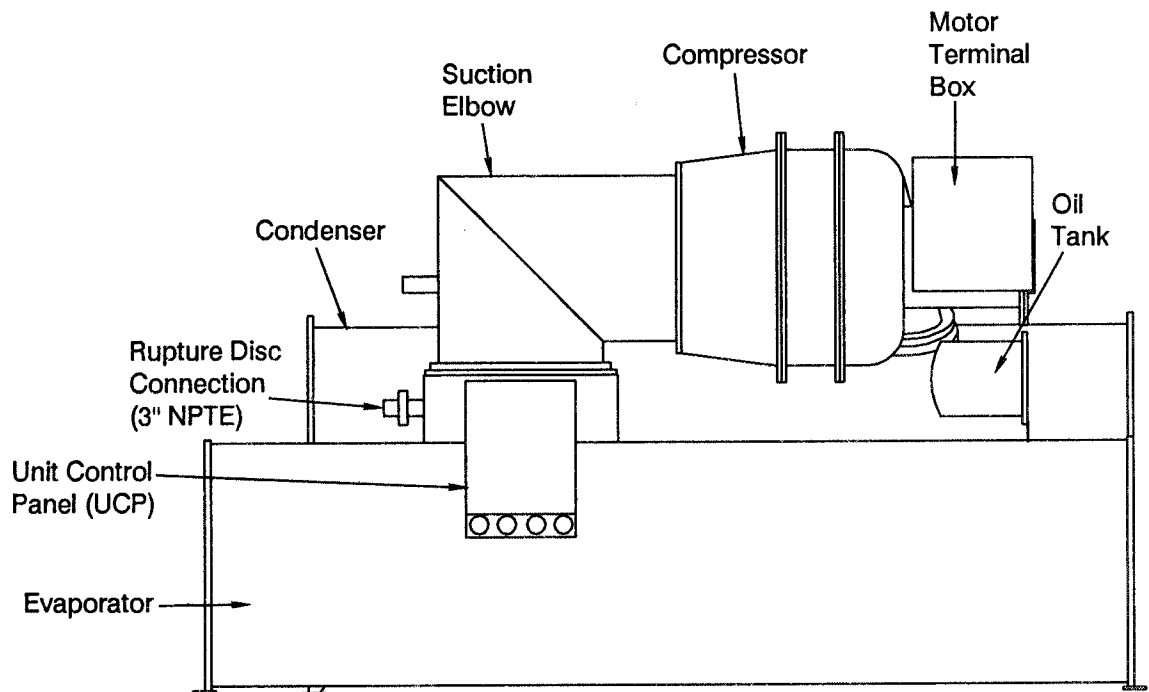

Figure 10
CVHF Pressure/Enthalpy Curve

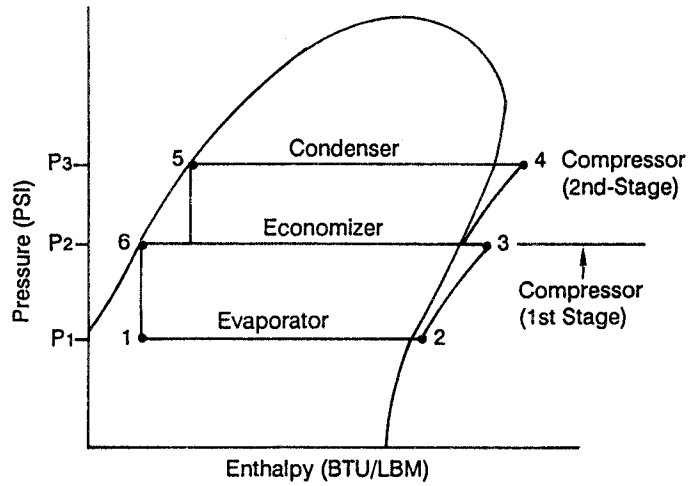
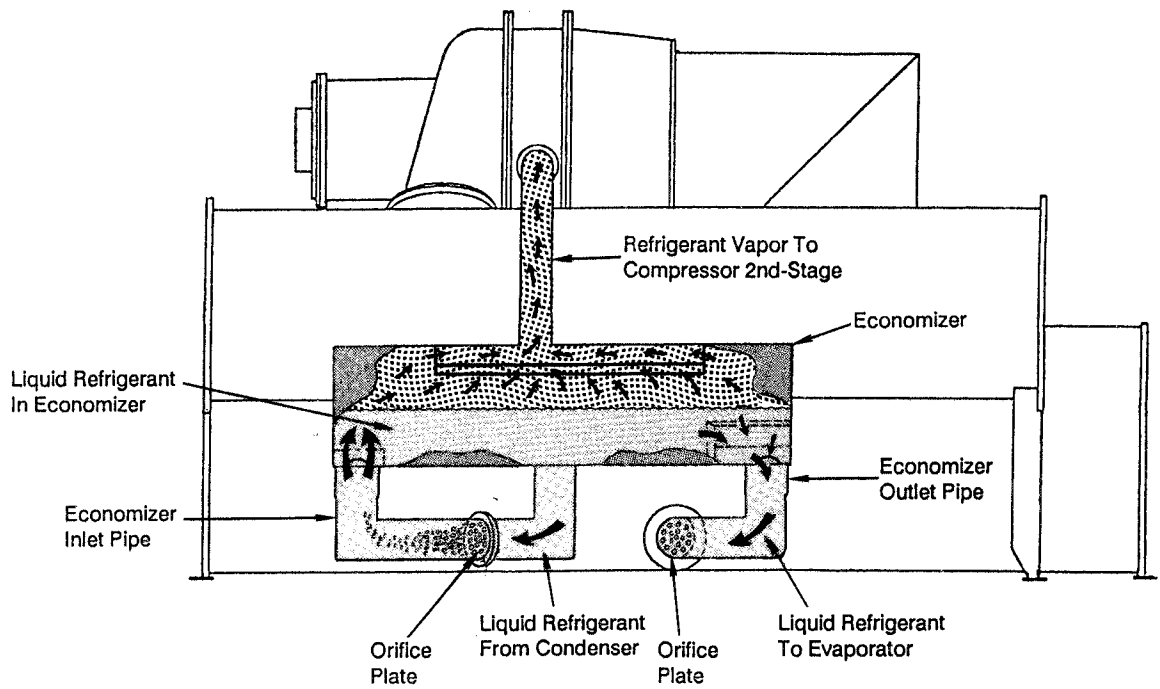

Figure 11
CVHF Economizer Operation



Compressor Lubrication System

The CVHF-1270 compressor lubrication system, which supplies oil to the compressor motor bearings, is illustrated in Figure 12.

Oil is pumped from the oil tank (i.e., by a pump and motor located within the tank) through an oil pressure-regulating valve designed to maintain a net oil pressure of 12 to 18 psid. It is then filtered and sent to the compressor motor bearings. On later-design CVHE and CVHF models, the oil filter assembly is equipped with refrigeration valves to isolate the filter during filter replacement. See "Replacing Oil Filter" on page 43.

From the bearings, the oil drains back to the oil tank through return lines. Notice that each oil return line is equipped with a sight glass; this enables the operator to check for oil flow when the oil pump is energized.

To ensure proper lubrication and prevent refrigerant from condensing in the oil tank, a 1000-watt heater is secured to the oil tank exterior. Operating in response to a signal from the UCP, this heater energizes as needed to maintain an oil tank temperature of 140 to 145 F (60-63 C) when the chiller is not running. When the chiller is operating, the temperature of the oil tank is typically 115 to 160 F (46-72 C).

The oil tank is vented between the compressor inlet vanes and the first-stage impeller suction cover. During normal system operation, motor barrel pressure is greater than that of the oil tank. Therefore, any gaseous refrigerant that enters the motor bearing cavities is drawn toward the oil tank where it is removed by the vent line. Any oil that collects in the suction cover area is pulled back to the oil tank by an ejector pump. This pump uses high pressure condenser gas to draw the oil from the suction cover area back to the ejector; from the ejector, the oil is discharged into the oil tank.

Note: CVHFs utilize a time delay relay and solenoid valve that temporarily close the oil sump vent line during the chiller start sequence. This prevents the loss of oil pressure that can occur during start-up by isolating the oil sump from the low-pressure cavity at the opposite end of the sump vent line.

Liquid refrigerant is used to cool the oil supply to the inboard motor bearing. Oil entering the oil cooler assembly from the oil tank (via the regulating valve and filter) flows into a coil inside the cooler shell. As the oil passes through this coil, it is cooled by a mixture of gaseous and liquid refrigerant that surrounds the coil exterior. Once the cooled oil leaves the cooler shell, it flows directly to the inboard motor bearing, and eventually returns to the oil tank.

The refrigerant-side of the oil cooler is piped into the return circuit of the motor cooling system. Part of the refrigerant that is used to cool the compressor motor passes through the oil cooler shell on its way to the economizer. (See "Motor Cooling System".

Motor Cooling System

CVHF compressor motors are cooled with liquid refrigerant. This pressurized cooling system is illustrated in Figure 13.

Liquid refrigerant flows from the condenser sump to the bottom of the compressor motor where it enters the motor chamber through a control orifice. When the liquid refrigerant contacts the warmer motor components, a portion of it flashes to a gas and cools the motor. This "flash" gas, along with any excess liquid refrigerant, then drains to the evaporator sump.

Because of the positive pressure differential between the condenser and evaporator, proper refrigerant flow through the motor is maintained at all load conditions.

Purge System

Because some sections of the chiller's refrigeration system operate at less than atmospheric pressure, the possibility exists that air and moisture may leak into the system. If allowed to accumulate, these non-condensibles become trapped in the condenser; this increases condensing pressure and compressor power requirements, and reduces the chiller's efficiency and cooling capacity.

The Trane Purifier Purge is the only purge system available for the CVHF chiller. The purge is designed to remove non-condensable gasses and water from the refrigeration system. Purifier Purge unit operation, maintenance and troubleshooting are covered by a separate PRGA operation and maintenance manual.

Figure 12
CVHF-1270 Motor Lubrication

Left End View

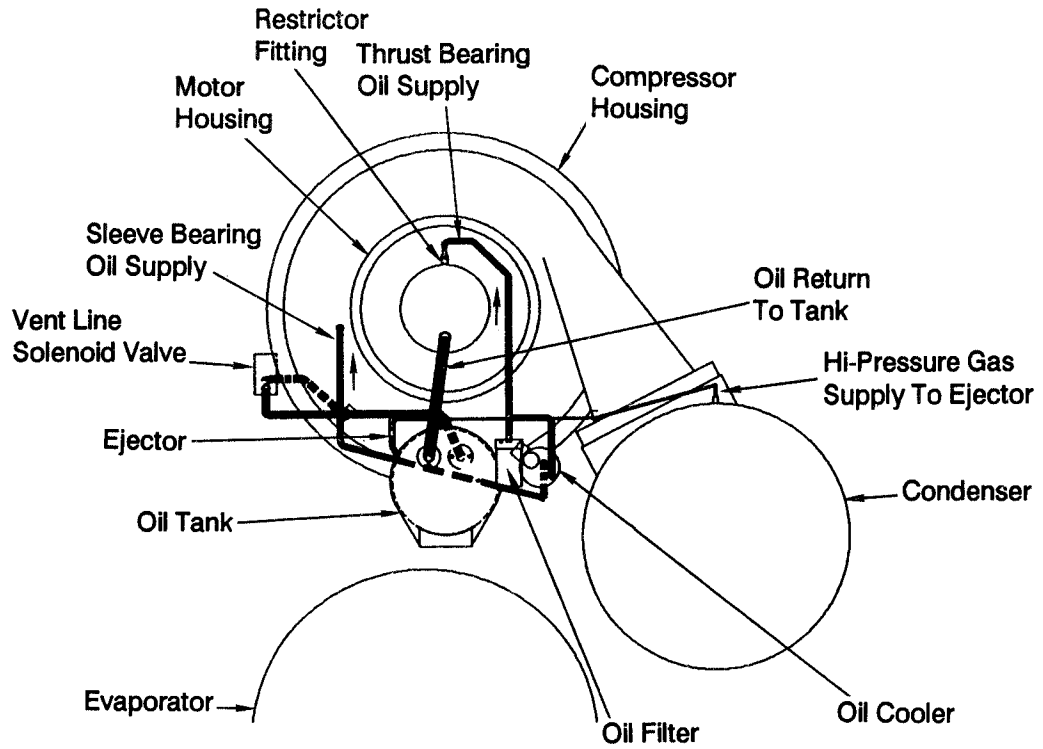

Back View

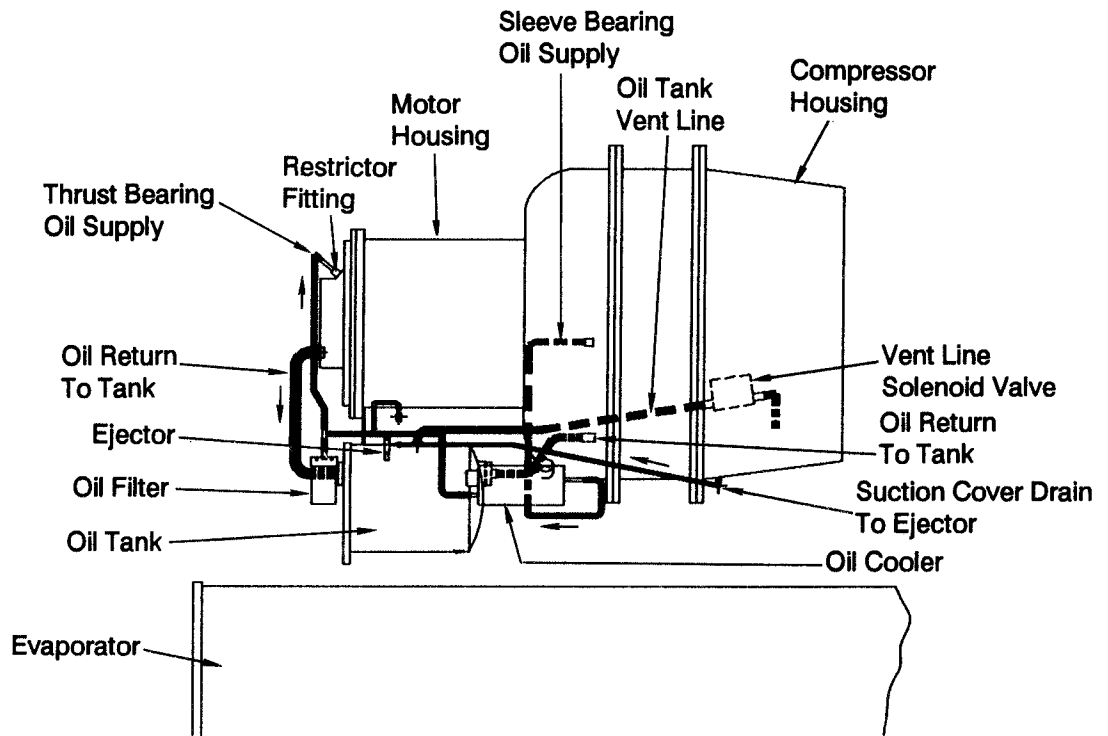
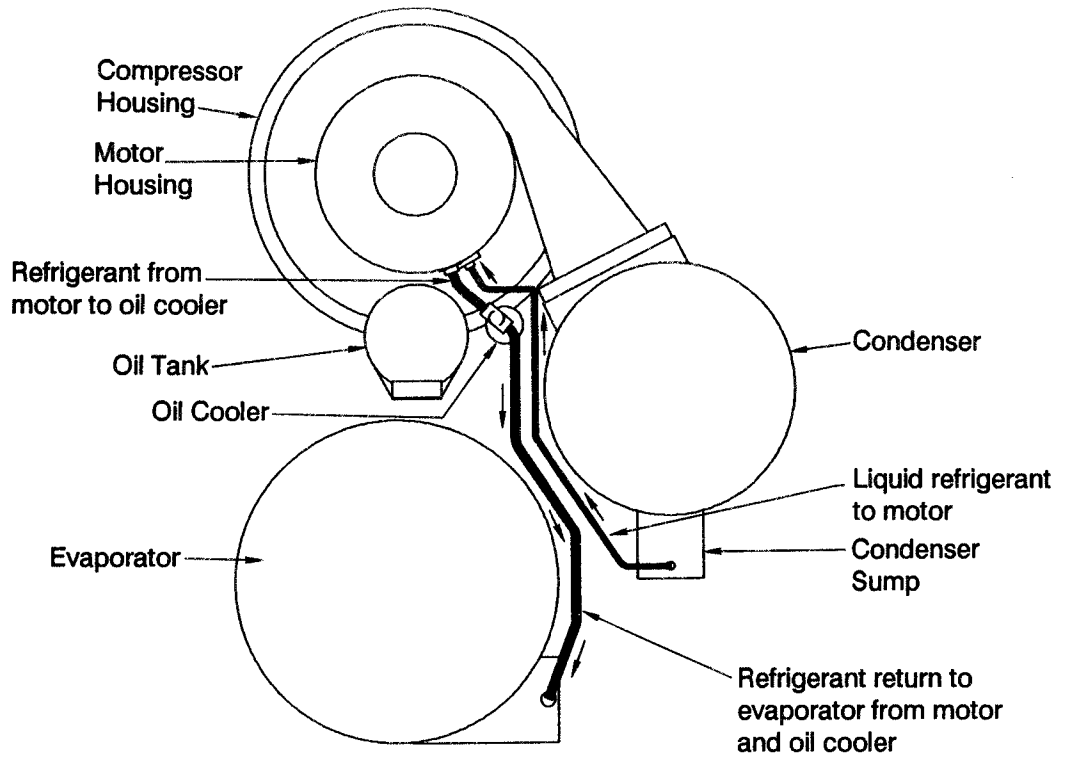
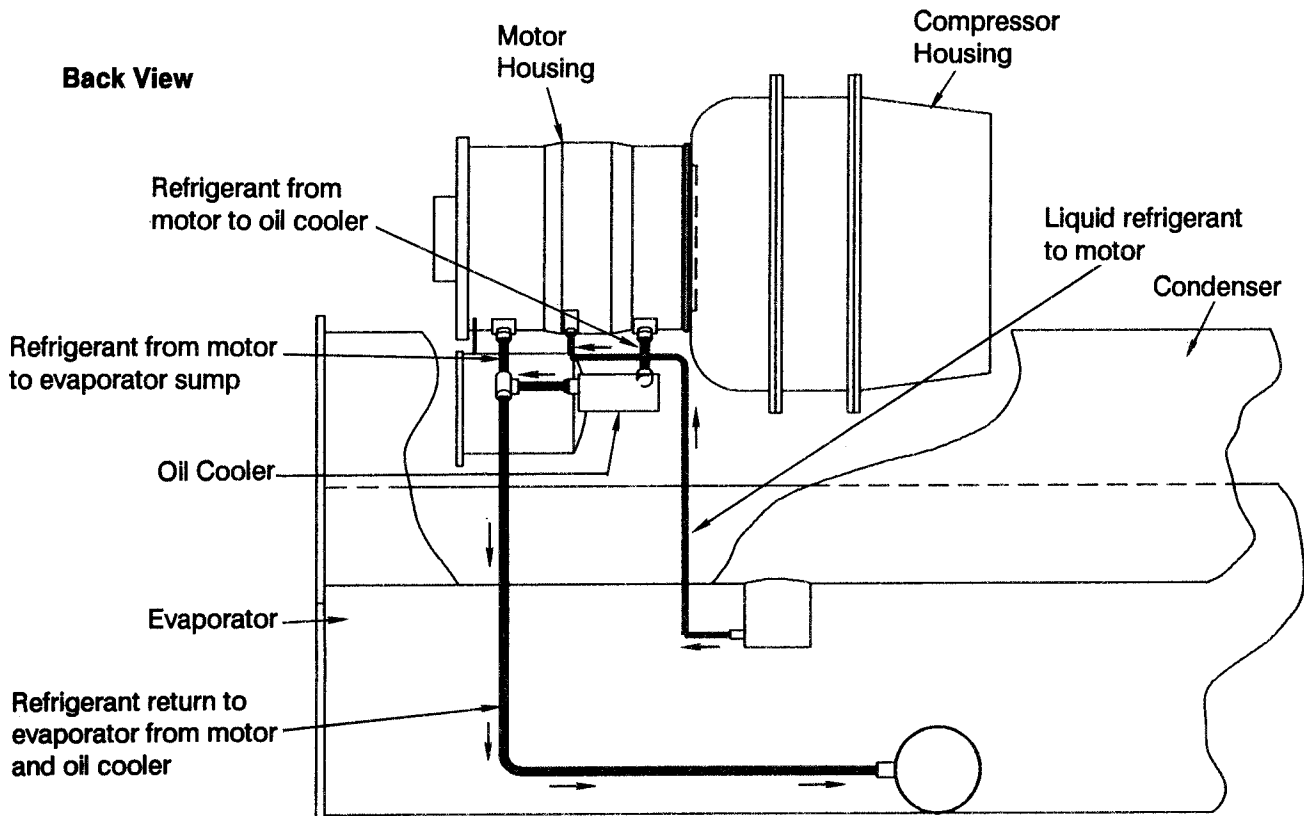

Figure 13
CVHF Motor Cooling System

Left End View



Back View



Chiller Control System

Operator Interface

Monitoring devices and all chiller control components requiring adjustment for normal chiller operation are accessible without opening the unit control panel door. These components which are a part of micro module 1U3 are illustrated in Figure 14.

Chiller Switch

Located above the "Display" block on the UCP, this 3-position switch enables the owner/operator to select the desired chiller control mode:

Standby/Reset. When power is applied to the unit with the chiller switch set at "Standby/Reset", the UCP is activated but unit operation is prohibited; operating code **A 0** appears on the display.

This switch position can be used by the operator or service technician to clear a latching diagnostic (i.e., fault that requires manual reset), or to shut down the unit.

Auto/Local. This switch position allows the unit to run automatically, using the operational setpoints set at the unit.

Auto/Remote. With the chiller switch in this position, the unit runs automatically using the setpoints established at a remote device and communicated to the chiller with the optional serial communication-interface (SCI).

If no setpoints are sent by the remote controller, the UCP uses the operational setpoints set at the unit control panel.

Note: When the unit is equipped with the SCI option, a remote device can place the unit in the "Standby/Reset" mode even though the chiller switch is in AUTO/REMOTE position. However, a latching diagnostic condition at the unit cannot be cleared from a remote device.

Figure 14
CVHB/E/F Operator Control Panel
(Accessible With UCP Door Closed)

IMPORTANT NOTE:

The CenTraVac UCM will control either the belt-driven or the Purifier Purge system. The UCM is configured at the factory to support the purge system at **Dip Switch No. 1** on switch block S9 of the UCM. If this switch is in the ON position, the UCM is configured for the belt-driven, water-cooled purge unit. If the switch is OFF, the UCM is configured for the air-cooled, Purifier Purge.

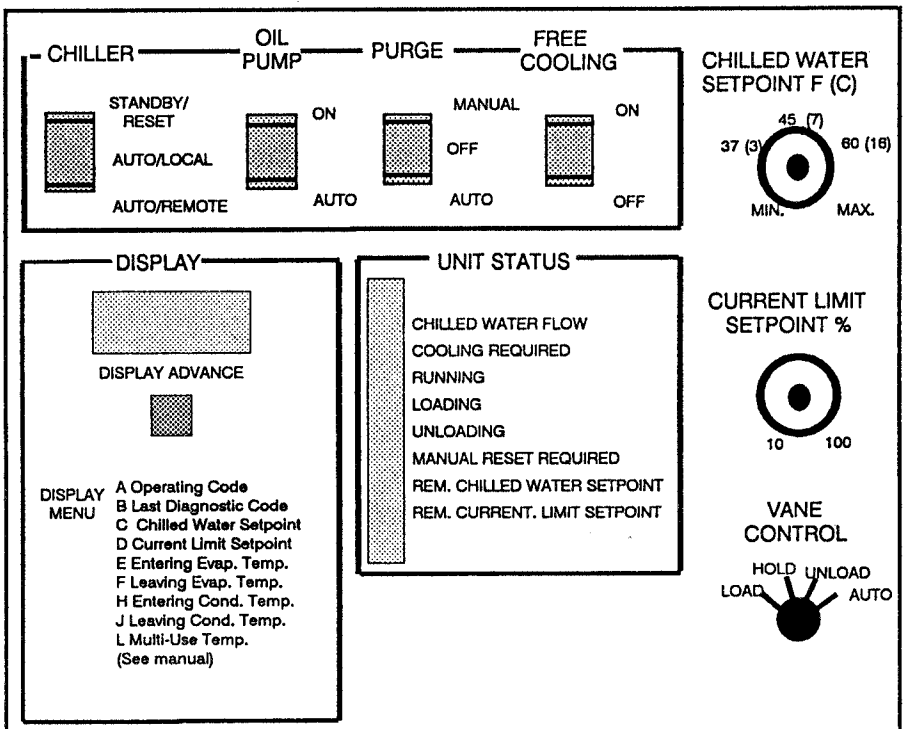

Oil Pump Switch

A 2-position oil pump switch is located to the right of the chiller switch, above the display window. Switch position functions are described below:

On. This switch position provides continuous operation of the oil pump, even when the chiller switch is in STANDBY/RESET position.

Note: The ON switch position is designed for use by service personnel only; do not leave it in this position! Compressor start-up will not occur if the oil pump switch is set at ON (i.e., latching diagnostic **b E8** will flash alternately with operating code **A 72** on the UCP's display).

Auto. Oil pump operation is controlled by the UCP, ensuring oil flow when the compressor is running. This is the normal switch operating position.

Purge Switch

Located next to the oil pump switch (see Figure 14), the purge switch enables the owner/operator to select 1 of 3 purge operational modes.

Manual. This switch position provides continuous operation of the purge regardless of centrifugal compressor operation, or the position of the chiller switch.

Off. Purge operation will not occur when the purge switch is set at this position.

WARNING: To prevent injury or death due to electrical shock, open unit disconnect switch before servicing to ensure purge unit is de-energized.

Auto. This is the normal switch

operating position. With this switch set at AUTO, the purge will run when the CenTraVac is in powered cooling operation.

If the chiller switch is set at STANDBY/RESET and the purge switch is set at AUTO, the purge unit is also shut down. However, if the chiller switch is set at STANDBY/RESET and the purge switch is set at MANUAL, the purge compressor will run continuously!

Note: On those units equipped with more than one condenser, purge only from the active condenser. Use the manual valves provided to isolate the inactive condenser.

Chilled Water Setpoint

Used to set the leaving chilled water temperature, this manually adjustable potentiometer is located at the righthand side of the window in the control panel door. See Figure 4; notice that dial settings range from MIN to MAX, with intermediate temperatures indicated in degrees (F), as well as degrees (C). Control "deadband" is ± 1 F.

To view the front panel chilled water setpoint, turn the vane control switch to HOLD and press the display advance pushbutton until the | — code prefix appears on the display. The integer value (in increments of 1 F or 1 C) immediately to the right of | — is the UCP's chilled water setpoint.

Remember that the standard chiller operating range is 37 F to 60 F, (3 to 16 C) while the temperature range for extended operation is 20 F to 70 F (-6 to 22 C.)

Note: To view the active chilled

water setpoint, check the entry for code prefix "C" of the operator's menu. When the chiller switch is set at AUTO/REMOTE and the remote chilled water setpoint status light is lit the "C" value displayed was entered at a remote system control panel (SCP).

Current Limit Setpoint

Located directly below the chilled water setpoint control, this manually adjustable potentiometer is used to register the desired current limit setpoint. Dial settings range from 40% to 100% of the compressor rated-load-amps (RLA) value.

To view the front panel current limit setpoint, turn the vane control switch to HOLD and press the display advance pushbutton until the — code prefix appears. The integer value (indicated in increments of 1%) at the immediate right of — is the UCP's current-limit setpoint.

Note: To check the active current limit setpoint, locate the entry displayed for code prefix **d** in the operator's menu. Whenever the chiller switch is set at AUTO/-REMOTE and the remote current limit setpoint status light is lit, the **d** value displayed was entered at a remote SCP.

Vane Control Switch

A 4-position, compressor inlet guide vane control switch is located beneath the current limit setpoint control. Each switch position is described below.

Load. As long as the vane control switch remains in this position, the "vanes open" (1U1Q7) relay is continuously energized and automatic vane control is suspended during the "Normal Run" mode (A 74).

Manual loading does not take precedence over the current limit (A 75), condenser limit (A 76) or evaporator limit (A 77) modes of operation.

Hold. With the vane control switch set at HOLD, both the "vanes open" (1U1Q7) and "vanes close" (1U1Q8) relays are de-energized, so the inlet guide vanes remain at their present position. In other words, automatic vane control is suspended when the chiller is operating in the "Normal Run" mode (A 74)

However, keep in mind that a current limit (A 75), condenser limit (A 76), or evaporator limit (A 77) operating mode will override the manual HOLD setting.

Note: Positioning the vane control switch at HOLD redefines the menu of codes appearing on the UCP's display. (See "Display" and Table 5.)

Table 5
UCP Display Menus

Operator's Menu		Servicemans's Menu (1, 2)	
Code Prefix	Parameter Description	Code Prefix	Parameter Description (and Display Range)
A	Operating Mode (see Table 16)	A	Operating Mode (see Table 16)
b	Last Diagnostic (see Table 17)	b	Last Diagnostic (see Table 17)
C	Active Chilled Water Setpoint: Std. Range = 37-60 F (3-16 C) Extd. Range = 20-70 F (-6-22 C)	T	Panel Chilled Water Setpoint (--, 20-70 F, ---)(--, -6-22 C, ---)
d	Active Current Limit Setpoint (40% thru 100% RLA)	—	Panel Current Limit Setpoint (--, 40% thru 100% RLA, ---)
E	Entering Evap. Water Temp. (Opt.) (--, 12-91 F, ---)(--, -11-33 C, ---)	—	Evaporator Refrigerant Temp. (3) (b Ad, -4-42 F, ---)(b Ad, -20-6 C, ---)
F	Leaving Evap. Water Temperature (b Ab, 12-91 F, ---)(b Ab, -11-33 C, ---)	L	Control Response Setpoint (1 thru 237)
H	Entering Cond. Water Temp. (Opt.) (--, 28-142 F, ---)(--, -2-62 C, ---)	□	Start Differential Setpoint (2-10 F) ((-17 thru -12 C)
J	Leaving Cond. Water Temp. (Opt.) (--, 28-142 F, ---)(--, -2-62 C, ---)	P	Condenser Limit Setpoint (80-120% HPC)
L	Multi-Use Temperature (4) (--, -5-135 F, ---)	U	Evap. Refg. Trip Setpoint (b A3) Std. Range = 29-34 F (-1 thru 1 C) Extd. Range = 0-34 F (-18 thru 1 C)

Notes:

1. To redefine the "operator's menu" to the "serviceman's menu" turn vane control switch to HOLD.
2. For additional information on any item listed in the "serviceman's menu", contact a qualified service organization.
3. Actual measured evaporator refrigerant temperature.
4. Examples of "Multi-Use Temp." applications are: Cond. Lvg. Refg. Temp.; CWR Ambient Temp.; CWR Temp. from Analog Input.

Unload. As long as the vane control switch remains in this position, the vanes close relay (1U1Q8) is continuously energized; automatic vane control is suspended regardless of the chiller's operating mode.

Auto. Inlet guide vane position is automatically controlled by the UCP when the vane control switch is set at this normal operating position.

Free Cooling Switch (Optional)

Free cooling enables the chiller to function as a simple heat exchanger, using refrigerant as the working fluid; however, it does not provide control of the leaving chilled water temperature.

When condenser water is available at temperatures lower than the desired chilled water temperature, the free cooling option provides "average selection" chiller capacity without operating the compressor.

A 2-position free cooling switch, located next to the purge switch (Figure 14), allows the operator to select from 1 of 2 operating positions:

On. Placing the free cooling switch in this position forces the chiller to enter the free cooling mode (A 9); the compressor shuts down if the unit is operating in the powered cooling mode.

Note: Operating code A 9 appears on the display once the free cooling valves are open. (The unit cannot return to the powered cooling mode until these valves are closed.) Remember, too, that when the UCP is equipped with the SCI option, a remote device can turn off free cooling operation while the free cooling switch is set at ON.

Off. This setting enables normal chiller operation within the parameters established for the powered cooling mode.

Unit Status Lights

A series of 8 status indicator lights are located directly below the purge switch. These blue lights, along with the operating and diagnostic information found on the display, allow the operator to monitor chiller operations. The purpose of each status indicator light is described below.

Chilled Water Flow. Illumination of this light indicates that chilled water flow switch 5S2 is closed.

Cooling Required. This light only illuminates when the UCP proves chilled water flow and detects a cooling requirement (i.e., leaving chilled water temperature exceeds the chilled water setpoint by a value greater than the differential-to-start criteria).

Running. Illumination of this status light indicates that:

- the unit is running (or is in one of the run modes);
- the chiller switch is set at AUTO/LOCAL or AUTO/REMOTE; and,
- the start sequence (or, transition) is complete.

It also remains lit through the chiller's post-lube cycle after the compressor shuts down.

Loading. When this light glows, the UCP is loading the unit (i.e., the vane actuator is driving the vanes open).

Unloading. When this light is on, the UCP is unloading the unit (i.e., the vane actuator is driving the vanes closed).

Note: It is normal for the Loading and Unloading status lights to flash on and off in short pulses.

Manual Reset Required. Illumination of this light indicates that the UCP has detected a latching diagnostic condition, and shut down the chiller. Operation cannot resume until the UCP is manually reset (i.e., chiller switch is turned to STANDBY/RESET, then back to AUTO/LOCAL or AUTO/REMOTE).

Remote Chilled Water Setpoint. When this light is on, the UCP is ignoring its front panel setpoint, and is using the chilled water setpoint that is:

- determined by the optional chilled water reset module, or;
- entered at a remote source (e.g., an SCP699 system control panel, or a Trane BAS).

If remote communications are severed, the UCP defaults to the control value of its front panel chilled water setpoint potentiometer.

Remote Current Limit Setpoint. Illumination of this light indicates that the UCP is using a current limit setpoint communicated from a remote source (e.g., SCP or Trane BAS), and is ignoring its front panel setpoint. Again, if remote communications are interrupted, the UCP defaults to the control value set with the current limit setpoint potentiometer.

Display

The UCP's display consists of a blue, 4-digit vacuum fluorescent display and a display advance pushbutton; both are located to the left of the unit status indicator lights. See Figure 14.

The first letter of the 4-character display identifies the type of data shown in the display window; a list of these indicator code and their meanings, is provided in Table 16. An abbreviated version of this list also appears on the face of the UCP, directly below the Display Advance pushbutton.

The 2 remaining alphanumeric characters of the display indicate unit operating mode, diagnostic condition, setpoints or actual temperatures as defined by the code prefix. Refer again to Table 6, as well as to Tables 5 and 7.

Table 6
Codes for Unit Operating Modes

3-Character Code	Operating Mode Description
Blank	Power Off
A 0	Standby/Reset
A 1	Auto (Local or Remote)
A 9	Free Cooling
A 70	Restart Inhibit
A 71	Establish Cond. Water Flow
A 72	Start
A 74	Run: Normal
A 75	Run: Current Limit (1)
A 76	Run: Condenser Limit (2)
A 77	Run: Evaporator Limit (3)
A 78	Run: Surge Condition
A 79	Post-Lube
A 88	Reset
A100	External Inhibit (Remote Start/Stop)

Notes:

1. As current limit setpoint is approached, 1U3 restricts further opening of the inlet guide vanes.
2. As condenser limit setpoint is reached, 1U3 restricts additional compressor loading to avoid shutdown on high condenser pressure (b F5) and initiates "head relief request" (i.e., optional relay).
3. 1U3 restricts further opening of the inlet guide vanes to avoid unit shutdown on low evaporator refrigerant temperature (b Fb).
4. 1U3 limits compressor loading and initiates "head relief request" (i.e., optional relay) when unit enters a surge condition. An automatic unit shutdown occurs if unit remains in surge for 15 minutes (b dA).

Notice that a code prefix of **A** or **b** is followed by a space and a 2-digit operating code (Table 6) or diagnostic code (Table 7), respectively.

Note: If the UCP detects a diagnostic condition, it alternately flashes the appropriate diagnostic code and unit operating mode (at the time of unit shutdown) on the display.

Table 7
Unit-Level Diagnostic Codes

Diag. Code	Diagnostic Explanation	Reset Type	Diag. Code	Diagnostic Explanation	Reset Type
b A3	Evaporator Refrig. Temp. Range	Manual	b E7	High Motor Temperature	Manual
b A4	Motor Temperature Sensor #1	Manual	b E8	Differential Oil Pressure Switch	Manual
b A5	Max. Acceleration Time Range	Manual	b E9	Stop Relay	Manual
b A7	Motor Temperature Sensor #2	Manual	b EA	High Inboard Brg. Temp. (Sen. #1)	Manual
b A8	Motor Temperature Sensor #3	Manual	b Eb	High Outbrd. Brg. Temp. (Sen. #2)	Manual
b A9	Oil Temperature Sensor	Manual	b EC	Running Overload	Manual
b Ab	Leaving Water Temp. Sensor	Manual	b Ed	Chilled Water Flow	Auto
b AC	Cond. Refrig. Pressure Sensor (3)	Manual	b EE	Max. Acceleration Time Exceeded	Manual
b Ad	Evap. Refrig. Temperature Sensor	Manual	b F0	Transition	Manual
b AE	Ambient Temperature Sensor (3)	Manual	b F1	Running External Interlock (3)	Manual
b AF	Bearing Sensor #1 (Inboard) (3)	Manual	b F2	Low Oil Pressure	Manual
b b0	Bearing Sensor #2 (Outboard) (3)	Manual	b F3	Low Oil Temperature	Auto
b d9	Extended Power Loss	Auto	b F4	High Oil Temperature	Manual
b dA	Surge	Manual	b F5	High Condenser Refrig. Pressure	Manual
b dC	Condenser Water Flow Overdue	Manual	b F7	Condenser Water Flow	Auto
b dE	Condenser Pressure Start Inhibit	Manual	b F8	Improper Unit Identification	Manual
b E2	Momentary Power Loss	Auto	b F9	Free-Cooling Valves	Manual
b E3	Phase Imbalance	Manual	b FA	Actuator	Manual
b E4	Phase Loss	Manual	b Fb	Low Evaporator Refrig. Temp.	Manual
b E5	Phase Reversal	Manual	b FF	Unit Control Module	Manual

Notes:

1. Check the "Manual Reset Required" status indicator light to determine if manual reset is necessary.
2. It is not possible to clear a latching diagnostic condition (i.e., one requiring manual system reset) at the unit from a higher-level device (e.g., an SCP699 or Trane BAS).
3. Optional feature.

Codes prefixed by a **C** or **d** are followed by the corresponding setpoint value (chilled water or current limit, respectively) presently used to control the chiller. If the chiller switch is set at **AUTO /LOCAL**, the setpoint values displayed are those set manually at the UCP- 695 control panel.

However, when the chiller switch is set at **AUTO/REMOTE**, and the applicable status indicator lights are on, the displayed setpoint values were established at a remote device (e.g., an SCP699 or Trane BAS).

The **E**, **F**, **H**, **J** and **L** code prefixes are followed by an actual measurement of a system parameter (e.g., entering evaporator water temperature). (Code prefixes **E**, **H**, **J** and **L** represent sensor options; if these sensors are not installed, a bar [—] appears on the display.)

Turning the vane control switch to **HOLD** redefines the display code prefixes to indicate the "local" (or front panel) chilled water and current limit setpoints, actual evaporator refrigerant temperature, and settings for control response, start differential, condenser limit and evaporator refrigerant "trip" point. See Table 8.

Important! Do not leave the vane control switch in **HOLD**. In this position, control of leaving chilled water temperature is suspended. Only the "safety" features are functional!

Note: While in the "serviceman's menu", the integer values displayed for the panel chilled water, condenser limit and evaporator refrigerant trip setpoints represent the entire adjustment range for these potentiometers. However, unless the chiller is specifically designed for "extended range" operation, the UCP will adhere to the operating parameters established for "standard range" chillers.

Use the display advance pushbutton to scroll from one menu entry to the next. The last "operator's menu" entry is **L** (multi-use temperature); to return to the top of the menu, press this pushbutton once.

Important! Advancing past the "Last Diagnostic Code" entry in either menu automatically clears the code registered there from the UCP's memory!

Table 8
Unit Time Delays and Safety Control Cutout Settings

Operating Controls: "Timers"	Timing Interval	System Reset	Operating Code (1)
Prelube (2)	15 seconds	n/a	A 72
Restart Inhibit (3):			
Winding Temp. < 165 F (74 C)	4 minutes	n/a	A 70
Winding Temp. ≥ 165 F	15 minutes	n/a	A 70
Since Last Start	30 minutes	n/a	A 70
Post-Lube	2 minutes	n/a	A 79
Free-Cool/Vane Open Inhibit (4)	3 minutes	n/a	A 9
Belt-Drive Purge: (purge switch @ AUTO)(5)	5 minutes ON 115 min. OFF	n/a	n/a
Purifier Purge: (purge switch @ AUTO)	Controlled by purge timer (6)	manual (7)	n/a
Sump Vent-Line Interval (8)	100 seconds	n/a	n/a
Safety Controls: Fault Time-Outs	Timing Interval	System Reset	Diagnostic Code (1)
Oil Pressure Overdue (2)	33 seconds	manual	b F2
Transition Complete Overdue	2 seconds	manual	b FO
Transition-from-Start Complete	Max. accel. timer setting	manual	b EE
Condenser Water Flow Overdue	3 minutes	manual	b dC
No Evaporator Water Flow	2 seconds max. w/o flutter	auto	b Ed
Vane Closure Overdue	3 minutes	manual	b FA
Free-Cool Valve Closure Overdue	3 minutes	manual	b F9
Surge	15 minutes	manual	b dA
Safety Controls: Unit Cutouts	Control "Trip" Point	System Reset	Diagnostic Code (1)
Winding Temp. Run Inhibit	265 ± 15 F* 130 ± 9 C*	manual	b E7
Low Oil Temp. Run Inhibit	100 ± 2 F 38 ± 1 C	manual	b F3
High Oil Temp. Run Inhibit	180 ± 2 F 83 ± 1 C	manual	b F4
High Bearing Temp. Run Inhibit (Optional)	180 ± 2 F 83 ± 1 C	manual	b EA, Eb
Lvg. Water Temp. Low Limit (Std. Range)	35 ± 1 F 2 ± .5 C	auto	n/a
Differential Oil Pressure Switch —	Closes Opens 11.5 - 15 psid 9 ± 1 psid	manual	b E8
High Pressure Cutout Switch —	Std. Units ASME Units 15 ± 1 psig 25 ± 1 psig (9)	manual	b F5
Oilless Purge "Extend Run" Press. Switch —	Closes Opens 20 psig 25 psig	n/a	n/a

Notes:

1. See Tables 6 and 7 for complete code listing.
2. Since prelube timing can begin at any point during 33-second "oil pressure overdue" interval, actual elapsed time to "establish oil pressure" and "prelube" can be anywhere from 15 to 48 seconds.
3. The 165 F inhibit applies only when unit is first powered-up, or if chiller switch is turned from STANDBY/RESET to AUTO/LOCAL or to AUTO/REMOTE. Otherwise, 30 minutes must elapse between compressor starts.
4. Operating code **A 9** will appear on operator display only when free cooling valve limit switches have opened.
5. See CVHE/B operation/maintenance manual for purge operation.
6. See "Electrical Sequence of Operation". Refer to Purifier Purge operation manual for details.
7. Reset at 3S6 or 6S6 on purge panel.
8. This timer closes sump vent line during prelube and during unit start sequence.
9. Fixed differential of 3-6 psid for switch closure on a rise in differential oil pressure.

Service Interface

Following is a brief description of UCP control components that can only be accessed by opening the control panel door. Each of these devices, as illustrated in Figure 15, is set at initial unit start-up by a qualified service technician.

WARNING: To prevent injury or death due to electrical shock, always open unit disconnect switch before opening control panel door.

Caution: To ensure proper chiller operation, never tamper with any UCP controls located behind the panel door without first consulting a qualified Trane service technician.

Clear Restart Inhibit Pushbutton

By pressing this pushbutton switch (i.e., located to the right of the chilled water setpoint potentiometer), the service technician can clear the restart inhibit timer.

Caution: The clear restart inhibit pushbutton is for use only by a qualified service technician. Using this button more than once in 30 minutes may seriously damage the motor.

Figure 15
UCM Service Interface and DIP Switch Locations
(Accessible Only With UCP Door Open)

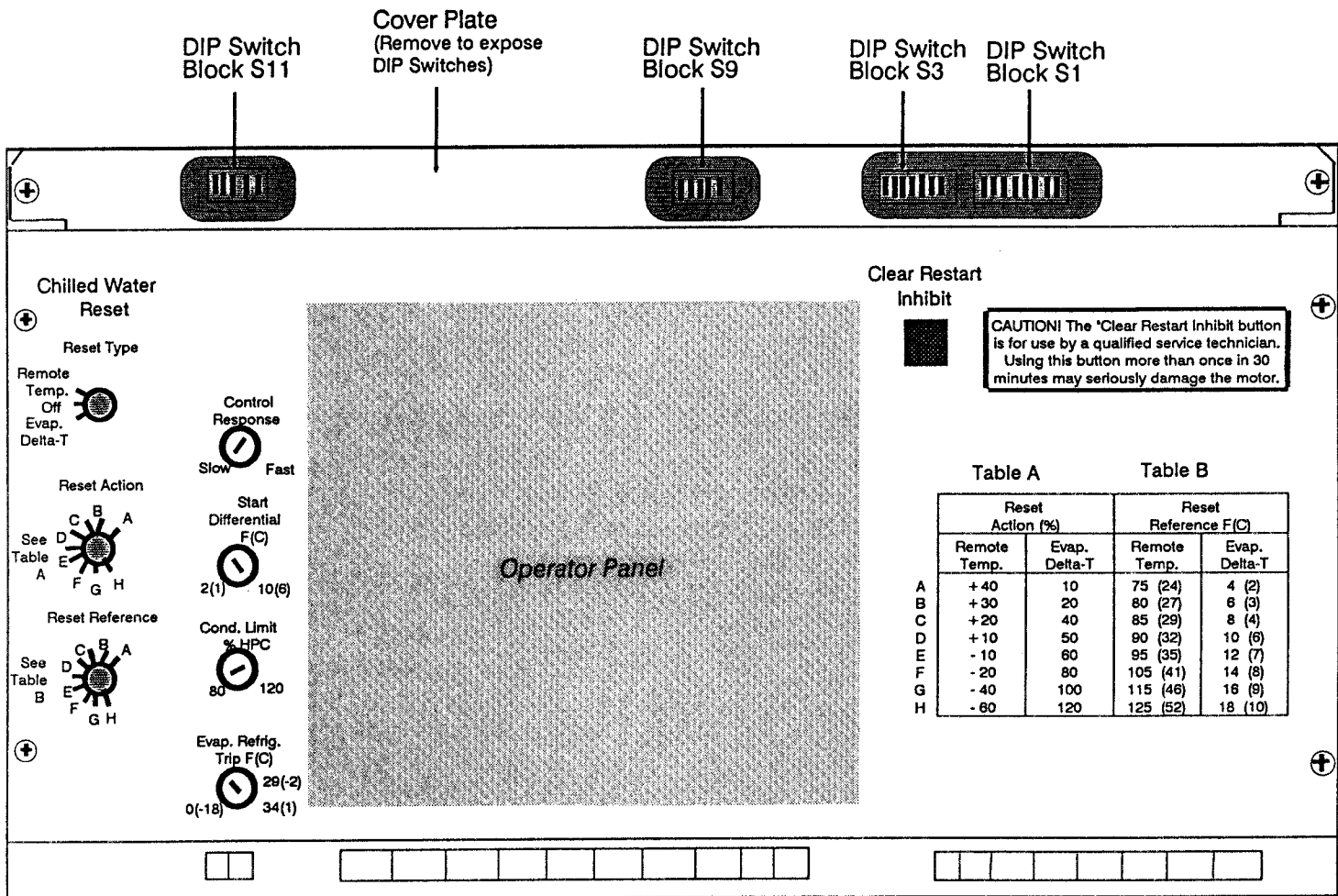

Control Response Setpoint

(To be set/calibrated by qualified Trane service technician only). Located to the left of the display window, this manually adjustable potentiometer can be set at any position between 1 and 237. (The units used to delimit these settings are arbitrary.)

The control response setting directly affects the vane controller's speed of response to changes in cooling requirements; the lower the control response setting, the slower the response time of the vane controller.

To view the actual control response setting, turn the vane control switch to HOLD and press the display advance pushbutton until code prefix **L** appears.

Start Differential Setpoint

(To be set by qualified Trane service technician only). With an adjustment range of 2-10 F (1- 6 C), this manually adjustable potentiometer establishes the number of degrees that the leaving chilled water temperature must rise above setpoint before the unit will start. (It also determines the actual compressor stop point; see "Fuse 1F2 Branch Circuit" under Electrical Sequence of Operation for further explanation.)

To view the actual start differential in the display window, turn the vane control switch HOLD and press the display advance pushbutton until code prefix **O** appears.

Condenser Limit Setpoint (% HPC; Optional)

(To be set by qualified Trane service technician only). Optional condenser limit control provides a means for maintaining chiller operation while high head pressure conditions exist.

The condenser limit potentiometer can be set at any point from 80% to 120% of the rated high pressure control trip point. For standard units with an HPC cutout of 15 psig, the condenser limit setting range is 12 to 18 psig. For ASME units with a HPC cutout setting of 25 psig, the condenser limit setting range is 20 to 30 psig.

Once this value is established, the UCP compares it with condenser refrigerant (head) pressure. As head pressure approaches the condenser limit setpoint, the UCP either slows/prohibits vane opening, or initiates a regulated vane closure.

The condenser high pressure cutout switch (1S1) remains active, and will shut down unit operation on latching diagnostic b F5 (i.e., "high condenser refrigerant pressure") if its trip point is exceeded.

To view the actual condenser limit setpoint on the UCP display, turn the vane control knob to HOLD and press the display advance pushbutton until the **| -** code prefix appears.

Evaporator Refrigerant Trip Setpoint

(To be set by qualified Trane service technician only). With a standard adjustment range of 29 to 34 F (-2 C to 1 C), this manually adjustable potentiometer is used to establish the chiller's low refrigerant temperature trip point. An optional "extended range" is also available which provides an adjustment range of 0 to 34 F (1 to 18 C).

To view the actual control setting, turn the vane control knob to HOLD and press the display advance pushbutton until the **U** code prefix appears.

Note: Attempting to adjust the evaporator refrigerant trip point below the minimum range value results in a latching diagnostic. (Diagnostic code **b A3** will flash alternately on the display with the operating code at the time the minimum range value was violated.)

Caution: To assure proper chiller operation, adjustment of this control must always be performed by a qualified service technician.

Electrical Sequence of Operation

Overview

This section will acquaint the operator with the control logic governing CVHB, CVHE and CVHF chillers equipped with UCP695-based control systems. Be sure to refer to the typical wiring schematic shown in Figure 16 when reviewing these step-by-step electrical sequences of operation.

Note: The typical wiring diagrams in Figure 16 are representative of standard units, and are provided only for general reference. They may not reflect the actual wiring of your unit. For specific electrical schematic and connection information, always refer to the wiring diagrams that shipped with the chiller.

With the supply power disconnect switch or circuit breaker (2CB1) closed, 120-volt control power is provided through control power transformer 2T4 and a 30-amp starter panel fuse (2F4) to terminal 1TB5-1 in the UCP control panel. From this point, control voltage flows to:

Fuse 1F2, supplying power to micro module 1U3 and the starter control, oil heater, and power supply transformer (1T1) circuits;

Fuse 1F3, supplying power to the oil pump and inlet vane actuator circuits; and,

Fuse 1F4, supplying power to the purge control system.

Although these 3 branch circuits energize simultaneously, the functions occurring in each circuit are described separately in the following paragraphs.

Fuse 1F2 Branch Circuit

120-Volt control power passing through fuse 1F2 travels to 5 separate subcircuits:

1. Low-voltage power is provided to micro module 1U3, relay output module 1U1 and power supply output module 1U2 through fuse 1F5 and power supply transformer 1T1.
2. Oil tank heater 4HR1 may be energized via the normally-open K6 contacts of power supply output module 1U2. (The status of these contacts open or closed is based on input from oil sump temperature sensor 4RT7.)

Note: UCP control logic is designed to energize the oil tank heater as required to maintain a sump temperature of 140 F to 145 F (60 C to 63 C) when the chiller is not running. If, at startup, oil temperature has not risen to a minimum temperature of 100 F, the unit will not start. A non-latching diagnostic code **b F3** will be displayed on the UCM. When oil temperature reaches 100 F, the unit will start and the diagnostic will clear.

Micro module 1U3 also monitors sensor 4R7 while the chiller is operating, and will shut down the unit on latching diagnostic **b F4** if oil sump temperature reaches 180 F (83 C).

3. Condenser water flow interlock circuit.
4. Chilled water flow interlock circuit.
5. Starter control circuit.

Chilled and Condenser Water Flow Interlock Circuits

Control voltage passing through fuse 1F2 also energizes the chilled and condenser water flow interlock circuits. Closure of flow switches 5S2 and 5S3 along with the auxiliary contacts of water pump contactors 5K1 and 5K2 in the interlock circuits energizes the chilled and condenser water pump relays (1K16, 1K17).

Notice that chilled water pump relay 1K16's normally-open, "proof-of-flow" contacts are connected between Terminals 1TB3-20 and 1TB3-21 in the low-voltage (<30V) section of the UCP control panel. (See Line 87 in Figure 16.)

Closure of the normally-open set of 1K17 contacts (Figure 16, Line 89) is the UCP's "proof-of-flow" signal for the condenser water circuit. Notice that this set of contacts is located in a low-voltage (<30V) input circuit connected to Terminals 1TB3-22 and 1TB3-23 on micro module 1U3.

Micro Module and "Wye-Delta" Starter Control Circuits

Individual access to the K1, K2 and K3 relays is not possible; however, the "net state" of all 3 relays is available between Terminals 8 and 9 on terminal block 1TB2. When the "net state" of the K1, K2 and K3 contacts along with condenser high pressure switch 1S1 is closed, control voltage passes to compressor start relay K4.

If cooling is required and all of the conditions required for start-up are met, micro module 1U3 sends a signal to power supply output module 1U2 to close the K4 contacts. This allows control voltage to flow to hour meter 1M1 and start counter 1M2; at the same time, a "start" signal is sent to pilot relay 2K5.

Notice that pilot relay 2K5 has 2 sets of normally-open contacts. The first set (Line 18; Figure 16) closes to lock the pilot relay into the control circuit around the K4 contacts.

Closure of the second set of 2K5 contacts (Line 19) allows control voltage to flow through the normally-closed auxiliary contacts of run contactor 2K2 (2M) and transition contactor 2K4 (1A) to the coil of shorting contactor 2K3 (S).

When shorting contactor 2K3 energizes, its normally-open, auxiliary contacts (Line 21) close; this allows control voltage to flow to the coil of start contactor 2K1.

With 2K1 now energized, its normally-open, auxiliary contacts (Line 22) close; this locks start contactor 2K1 into the control circuit around the auxiliary 2K3 contacts in Line 21 (Figure 16). Power is now supplied to the "wye" ("star") windings of compressor motor 4B1 through starter contactors 2K1 and 2K3.

As the compressor accelerates, motor current draw decreases. When current draw drops to 85% of RLA, micro module 1U3 sends a signal to power supply output module 1U2 to close the normally-open contacts of compressor transition relay K5.

This energizes the coil of transition contactor 2K4 and causes its normally-closed set of auxiliary contacts (Line 19) to open.

With the circuit to shorting contactor 2K3 now open, 2K3 de-energizes and its normally-closed, auxiliary contacts (Line 22) reclose to allow control power to reach the coil of run contactor 2K2. Once the auxiliary set of normally-open 2K2 contacts in Line 23 closes, run contactor 2K2 is locked into the control circuit around the auxiliary, normally-open 2K3 and 2K1 contacts (Lines 21 and 22).

A normally-closed set of auxiliary 2K2 contacts also opens in Line 19 to interrupt control voltage to transition contactor 2K4.

Now that the "delta" motor windings are energized, compressor 4B1 is operating in its normal "run" mode; it will continue to do so until the "net state" of the K1, K2 and K3 contacts (Line 16) is open. Once this "open" condition occurs, voltage to pilot relay 2K5 is lost and its contacts reopen.

Any of the following events will result in a "net state" of "open" for contacts K1, K2 and K3, and stop compressor operation:

1. Turning the chiller switch to STANDBY/ RESET;
2. UCP detection of a latching or non-latching diagnostic condition; or,
3. Satisfaction of the cooling requirement (i.e., building load drops to the point where machine operation is no longer practical).

Determination of an actual compressor "stop" point based on satisfaction of cooling demand hinges on the start differential setpoint. The relationship between this setpoint and the UCP's "shut-down" criteria is shown in Table 8 on page 31.

Figure 16 - Typical Electrical Schematic for Standard CVHB, CVHE or CVHF w/Wye-Delta, Remote-Mounted Starter (Page 1)

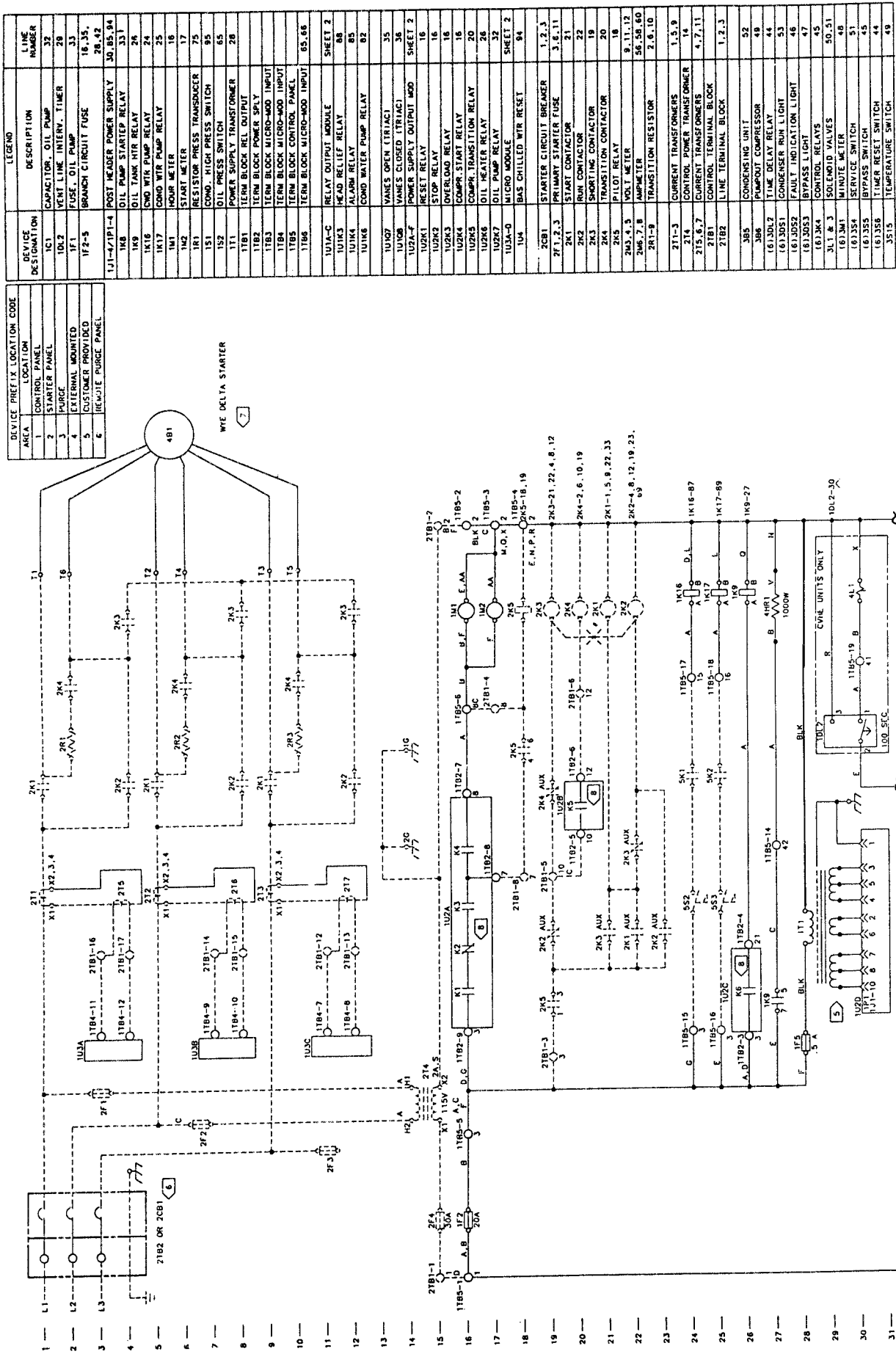

DEVICE AREA	PREFIX	LOCATION CODE
1	CONTROL PANEL	
2	STARTER PANEL	
3	PURGE	
4	EXTERNAL MOUNTED	
5	CUSTOMER PROVIDED	
6	REMOTE PURGE PANEL	

DEVICE DESIGNATION	DESCRIPTION	LINE NUMBER
1C1	CAPACITOR OIL PUMP	32
1D2	WST LINE INTERV. TIMER	33
1F1	FUSE OIL PUMP	33
1F2-5	BRANCH CIRCUIT FUSE	18, 35, 18, 42, 30, 85, 94
1J1-7/1P1-4	POST HEADER POWER SUPPLY	30, 85, 94
1H8	OIL PUMP STARTED RELAY	33, 1
1K16	OIL TANK HTR RELAY	24
1K17	COND WTR PUMP RELAY	24
1M1	START METER	18
1M2	RESISTOR PRESS TRANSDUCER	75
1S1	COND. HIGH PRESS SWITCH	95
1S2	OIL PRESS SWITCH	65
1T1	POWER SUPPLY TRANSFORMER	28
1T2	TERM BLOCK REL OUTPUT	
1T3	TERM BLOCK MICRO-MOD INPUT	
1T4	TERM BLOCK MICRO-MOD INPUT	
1T5	TERM BLOCK CONTROL PANEL	
1T6	TERM BLOCK MICRO-MOD INPUT	65, 66
1U1A-C	RELAY OUTPUT MODULE	SHEET 2
1U1K3	HEAD RELIEF RELAY	88
1U1K4	ALARM RELAY	85
1U1K6	COND WATER PUMP RELAY	82
1U1Q7	VANES OPEN (TR1AC)	35
1U1Q8	VANES CLOSED (TR1AC)	36
1U2A-F	POWER SUPPLY OUTPUT MOD	SHEET 2
1U2K1	RESET RELAY	16
1U2K2	STOP RELAY	16
1U2K3	OVERLOAD RELAY	16
1U2K4	COMP. START RELAY	20
1U2K5	COMP. TRANSITION RELAY	20
1U2K6	OIL HEATER RELAY	28
1U2K7	OIL PUMP RELAY	33
1U3A-D	MICRO MODULE	SHEET 2
1U4	BAS CHILLED WTR RESET	84
2CB1	STARTER CIRCUIT BREAKER	1, 2, 3
2F1, 2, 3	PRIMARY STARTER FUSE	3, 6, 11
2K1	START CONTACTOR	21
2K2	RUN CONTACTOR	22
2K3	SHORTING CONTACTOR	19
2K4	TRANSITION CONTACTOR	20
2K5	PILOT RELAY	18
2M5, 7, 8	VOLT METER	9, 11, 12
2M6, 7, 8	AMP METER	56, 58, 60
2R1-8	TRANSITION RESISTOR	2, 6, 10
2T1-3	CURRENT TRANSFORMERS	1, 5, 9
2T4	CONTROL POWER TRANSFORMER	14
2T5, 6, 7	CURRENT TRANSFORMERS	4, 7, 11
2T81	CONTROL TERMINAL BLOCK	
2T82	LINE TERMINAL BLOCK	1, 2, 3
3B5	CONDENSING UNIT	52
3B6	PUMP/OUT COMPRESSOR	49
16JDL2	TIME DELAY RELAY	44
16JDS1	CONDENSER RUN LIGHT	53
16JDS2	FAULT INDICATION LIGHT	46
16JDS3	FAULT LIGHT	47
16J3K4	CONTROL RELAYS	45
3L1 & 3	SOLENOID VALVES	60, 51
16JM1	MINUTE METER	48
16J3S4	SERVICE SWITCH	51
16J3S5	BYPASS SWITCH	44
16J3S6	TIMER RESET SWITCH	44
3J515	TEMPERATURE SWITCH	49

Continued on next page)

(Continued from previous page)

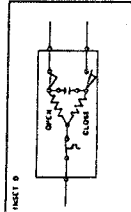
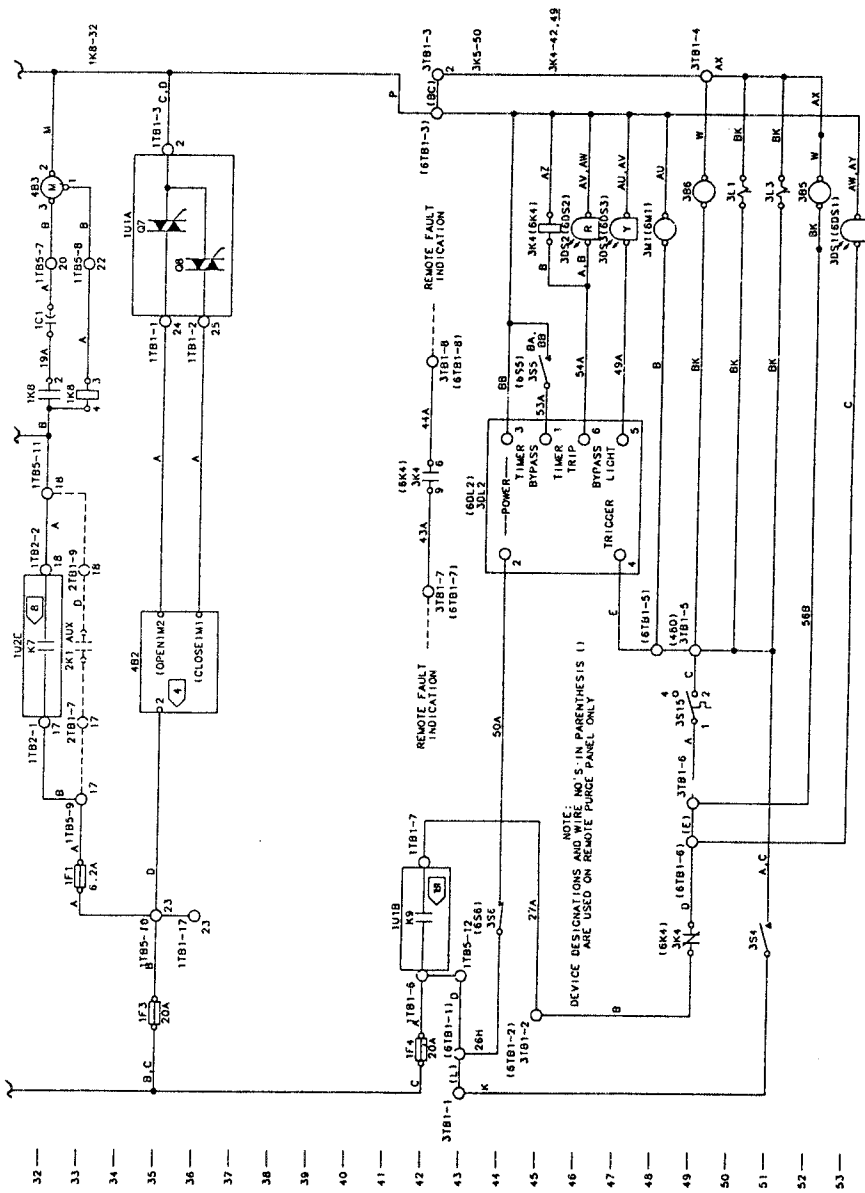

3781	PURGE TERMINAL BLOCK	65
(1671)	REMOTE PANEL TERM. BLOCK	N/A
483	COMPRESSOR MOTOR	82
482	MOTOR WINDING TEMP SENSOR	88
482.3.4	WANE ACTUATOR MOTOR	32
483	OIL PUMP MOTOR	27
481	OIL TANK HEATER	30
4L1	VENT LINE SOLENOID	69-80
4RT1-9	THERMISTOR	
5051	ALARM INDICATION	85
5K1	COND WATER PUMP CONT. AUX	84
5K2	COND WATER PUMP CONT. AUX	84
5K3	ALARM RELAY	88
5K4	HEAD RELIEF REDALST. CONT.	24
5S2	COND WATER FLOW SWITCH	25
5S3	COND WATER FLOW SWITCH	67
5S4	INTERLOCK SWITCH	

- NOTES:
- SOLID LINES INDICATE TRUNK WIRING. DASHED LINES INDICATE FIELD WIRING. PHANTOM LINES INDICATE OPTIONAL FEATURES OR ALTERNATE CIRCUITRY.
 - UNLESS OTHERWISE NOTED, ALL SWITCHES ARE SHOWN IN THE NORMAL POSITION. SWITCHES ARE TURNED OFF AND AFTER A NORMAL SHUTDOWN HAS OCCURRED. RELAY HUMIDITY WITH ALL UTILITIES TURNED OFF.
 - NUMBERS ALONG THE RIGHT SIDE OF THE SCHEMATIC INDICATE THE LOCATION OF THE CONTACTS BY LINE NUMBER. AN UNDERLINE ON THE CONTACTS BY LINE NUMBER INDICATES A CLOSED CONTACT. AN OPEN ARROWHEAD BELOW THE LINE WHICH BEGINS TRUNKING WHICH IS ENERGIZED.
 - SEE INSET D FOR TYPICAL INTERNAL WIRING OF ACTUATOR.
 - SEE SERVICE MANUAL FOR INDIVIDUAL SECONDARY VOLTAGES.
 - THREE PHASE POWER SUPPLY VOLTAGE - SEE UNIT NAMEPLATE.
 - REMOTE STARTER SHOWN AND WIRING BETWEEN CONTROL PANEL AND STARTER IS NOT SHOWN. SEE STARTER MANUFACTURER'S WIRING DIAGRAM FOR SPECIFIC WIRING.
 - RELAY COILS NOT SHOWN. CONTACTS ARE CONTROLLED BY RELAY COILS OF THE MICRO-MODULE (1103). SEE SEQUENCE OF OPERATION LINES 108 - 115 NEXT PAGE.

WARNING
DISCONNECT ELECTRIC POWER SUPPLY BEFORE SERVICING TO PREVENT INJURY OR DEATH DUE TO ELECTRICAL SHOCK.

AVERTISSEMENT
DEBRANCHER DU CIRCUIT D'ALIMENTATION ELECTRIQUE AVANT L'ENTREPRISE DE REPARATION POUR EVITER BLESSURE OU MORT PAR ELECTROCUTION.

CAUTION
USE COPPER CONDUCTORS ONLY TO PREVENT EQUIPMENT DAMAGE. UNIT TERMINALS ARE NOT DESIGNED TO ACCEPT ANY OTHER WIRING.

ATTENTION
UTILISER SEULEMENT DES CONDUCTEURS EN CUIVRE POUR EVITER LES DOMMAGES A L'EQUIPEMENT. LES BORNES NE SONT PAS PREVUES POUR AUTRES TYPES DE FILS CONDUCTEURS.

X39470573A

Figure 16 (Page 2)

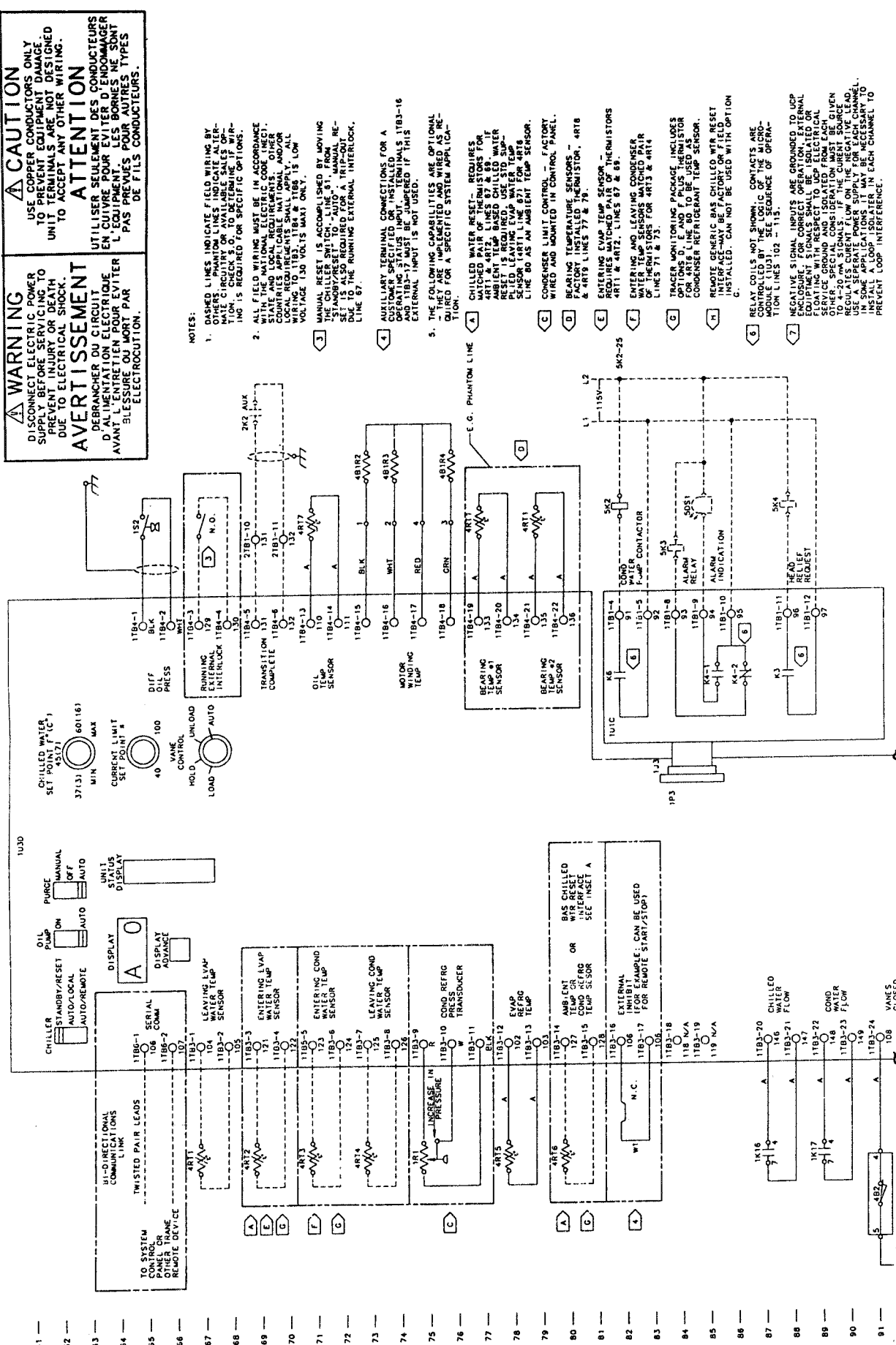

WARNING
DISCONNECT ELECTRICAL POWER TO PREVENT INJURY OR DEATH DUE TO ELECTRICAL SHOCK.
AVERTISSEMENT
DEBRANCHER DU CIRCUIT D'ALIMENTATION ELECTRIQUE AVANT TOUTE REPARATION OU TRAVAIL D'ELECTROCOUCTION.

CAUTION
USE COPPER CONDUCTORS ONLY TO PREVENT EQUIPMENT DAMAGE. UNIT TERMINALS ARE NOT DESIGNED TO ACCEPT ANY OTHER WIRING.
ATTENTION
UTILISER SEULEMENT DES CONDUCTEURS EN CUIVRE POUR EVITER LES DOMMAGES A L'EQUIPEMENT. LES TERMINAUX NE SONT PAS PREVUS POUR AUTRES TYPES DE FILS CONDUCTEURS.

- NOTES:
- DASHED LINES INDICATE FIELD WIRING BY OTHERS. PHANTOM LINES INDICATE ALTERED CIRCUITS OR TO BE WIRING TO BE OBTAINED IN THE RUNNING EXTERNAL INTERLOCK. L1 IS REQUIRED FOR SPECIFIC OPTIONS.
 - ALL FIELD WIRING MUST BE IN ACCORDANCE WITH THE NATIONAL ELECTRIC CODE (NEC), STATE AND LOCAL REQUIREMENTS. OTHER LOCAL REQUIREMENTS SHALL APPLY. ALL WIRING TO 118B-17 & 118B-15 LOW VOLTAGE 130 VOLTS MAX ONLY.
 - MANUAL RESET IS ACCOMPLISHED BY MOVING SWITCH TO "MANUAL" POSITION. "MANUAL RESET" IS ALSO REQUIRED FOR A TRIP-OUT LINE 97.
 - AUXILIARY TERMINAL CONNECTIONS FOR A CUSTOMER SPECIFIED OR INSTALLED OPERATING STATUS INPUT (TERMINALS 118B-16 EXTERNAL INPUT IS NOT USED).
 - THE FOLLOWING CAPABILITIES ARE OPTIONAL - THEY ARE IMPLEMENTED AND WIRED AS REQUIRED FOR A SPECIFIC SYSTEM APPLICATION.
 - CHILLED WATER RESET - REQUIRES 481A-1, 481A-2, 481A-3 & 481A-4. AMBIENT TEMP BASED CHILLED WATER RESET IS REQUIRED FOR WATER TEMP SENSOR (ART LINE 87) FOR 481B LINE 80 AS AN AMBIENT TEMP SENSOR.
 - CONDENSER LIMIT CONTROL - FACTORY WIRED AND MOUNTED IN CONTROL PANEL.
 - BEARING TEMPERATURE SENSORS - FACTORY INSTALLED THERMISTOR, 481B & 481B LINES 77 & 78.
 - ENTERING EVAP TEMP SENSOR - REQUIRES CHANGES AT 481B LINES 67 & 68.
 - ENTERING COND REFRIG CONDENSER REFRIGERANT TEMP SENSOR - REQUIRES CHANGES AT 481B LINES 71 & 73.
 - TRACER MONITORING PACKAGE INCLUDES OPTIONS D, E AND F. PLUS THERMISTOR CONDENSER REFRIGERANT TEMP SENSOR.
 - BEARING TEMP SENSOR - CHILLED WATER INTERFACE - MAY BE FACTORY OR FIELD INSTALLED. CAN NOT BE USED WITH OPTION G.
 - RELAY COILS NOT SHOWN. CONTACTS ARE SHOWN IN L103. SEE SEQUENCE OF OPERATION LINES 102 - 113.
 - NEGATIVE SIGNAL INPUTS ARE GROUNDED TO GCP ENCLOSURE. FOR CORRECT OPERATION, EXTERNAL EQUIPMENT SIGNALS MUST BE SUPPLIED TO SERVICE GROUND AND ISOLATED FROM EACH OTHER. SPECIAL CONSIDERATION MUST BE GIVEN TO REGULATING CURRENT FLOW ON THE NEGATIVE LEAD. USE A SEPARATE POWER SUPPLY FOR EACH CHANNEL. INSTALL A LOOP ISOLATOR IN EACH CHANNEL TO PREVENT LOOP INTERFERENCE.

(Continued on next page)

(Continued from previous page)

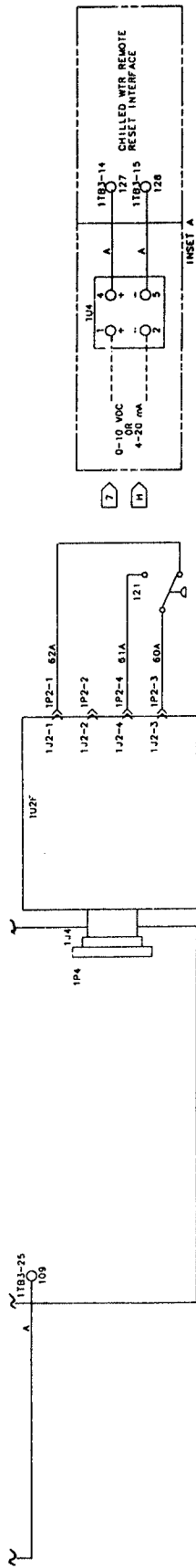

SEQUENCE OF OPERATION

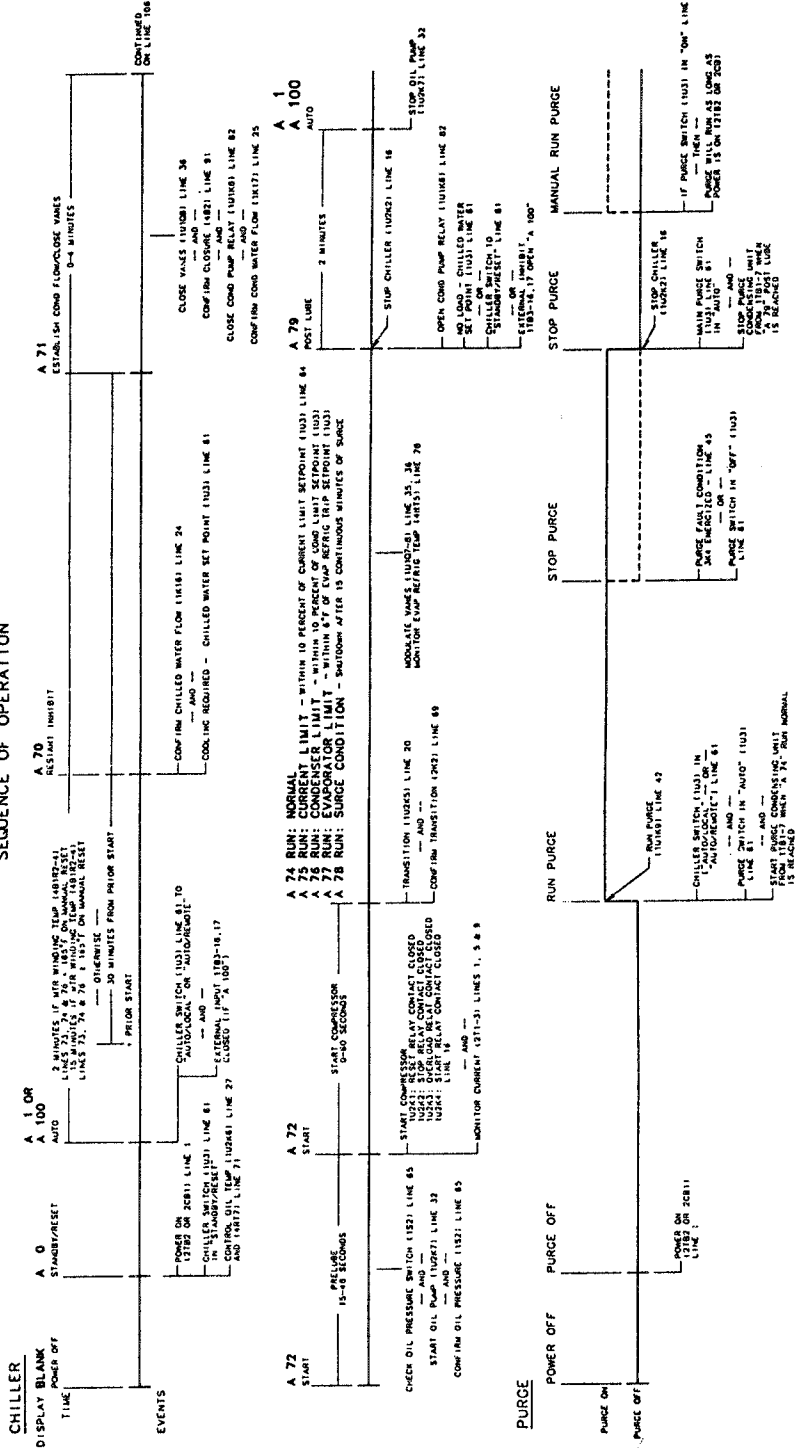

Fuse 1F3 Branch Circuit

Oil Pump Circuit

120-Volt control power from control power transformer 2T4 flows through branch circuit fuse 1F3 and Terminal 1TB5-10 to a 6.2-amp fuse (1F1). Fuse 1F1 protects the oil pump motor (4B3) from overamperage conditions.

Current, passing through fuse 1F1 reaches 2 normally-open, parallel sets of contacts; those of oil pump relay K7 and start contactor 2K1. K7's contacts are located on power supply output module 1U2, but contact status open or closed is governed by micro module 1U3.

Note: While the K7 contacts are automatically closed by 1U3 as a part of the start sequence, they can also be closed manually by adjusting the oil pump switch from AUTO to ON.

With the K7 contacts closed, vent-line interval timer 1DL2 energizes and closes its set of normally-open contacts for 100 seconds. During this period, closure of vent-line solenoid valve 4L1 isolates the oil sump from the compressor to prevent loss of oil pressure. When the 100-second interval expires, 1DL2's contacts reopen and solenoid valve 4L1 de-energizes to reopen the oil sump vent line.

Closure of the K7 contacts also allows current to pass through the coil of oil pump starter relay 1K8 to the "run" windings of oil pump motor 4B3.

When motor 4B3 first starts, current draw is high; this causes current-sensing relay 1K8 to close its normally-open contacts (Line 31; Figure 16) and "pull in" oil pump capacitor 1C1. With this circuit complete, current now flows to the "start" windings of the oil pump motor.

As the pump motor accelerates, its amp draw eventually falls below the "capacitor-enable" threshold of relay 1K8. Once this occurs, 1K8 reopens its normally-open contacts, and power is supplied only to the "run" windings of motor 4B3.

The normally-open, auxiliary 2K1 contacts (Line 33) that parallel those of oil pump relay K7 (Line 32) are located on start contactor 2K1. As soon as 2K1 energizes, these auxiliary contacts close. Notice that completion of this circuit assures that voltage is provided to the oil pump motor as long as the compressor motor is operating.

Oil pump operation ceases when both the K7 (Line 32) and auxiliary 2K1 (Line 33) contacts open.

Vane Actuator Circuit

Control power passing through branch circuit fuse 1F3 and Terminal 1TB5-10 not only energizes the oil pump circuit, but also provides power to the inlet vane actuator circuit. See Figure 16; notice that current enters vane actuator motor 4B2 at Terminal 2. (Inset D of this schematic indicates typical, internal actuator wiring.)

Voltage entering the actuator at Terminal 2 passes through a thermal overload protection device to the "open" and "close" sets of actuator motor windings. A capacitor is connected to the opposite ends of these windings to provide the capacitance needed to start and run the vane actuator motor.

Current, flowing from the "open" motor winding, passes through an end switch and out of the actuator at Terminal M2, while current flowing through the "close" motor winding passes through another end switch and out of the actuator at Terminal M1.

Caution: To prevent actuator damage resulting from overheated motor windings, adjust motor end switches to open motor circuits before actuator drive arm reaches travel limit.

Inlet vane actuator is controlled by 2 Triac switches (Q7, vanes open; Q8, vanes closed) located in relay output module 1U1. Functionally, Q7 and Q8 each operate like a simple set of contacts.

While the operation of both Triacs is automatically governed by micro module 1U3, manual control is possible by turning the vane control switch to LOAD, HOLD or UNLOAD.

Note: Manual loading or holding does not take precedence over the current limit (A 75), condenser limit (A 76) or evaporator limit (A 77) modes of operation.

Fuse 1F4 Branch Circuit (Purge Unit)

The following paragraphs discuss electrical operation of the Purifier purge. A more detailed sequence of operation is available in the Purifier Purge Operation and Maintenance manual. Electrical operation of previous-design purge systems is discussed in the chiller operation and maintenance literature.

Control power (120 volts) is provided to the purge circuit through a 20-amp branch circuit fuse (1F4). From this point, two paths are provided. The first connects directly to purge terminal 3TB1-1 and provides a continuous power supply to the service pumpout switch (3S4) and the 24-hour fault time relay (3DL2). The second path connects through the normally-open K9 purge relay contacts (Line 42) located in relay output module 1U1, to purge terminal 3TB1-2. The K9 relay is controlled by the microprocessor in the unit control panel and is dependent on:

- the position of the purge switch at the control panel;
- the position of dip switch 1 on block S9, and;
- the operational state of the chiller.

Note: The CenTraVac UCM will control either the older-style belt-driven purge unit or the Purifier Purge system. The UCM is configured at the factory to support the proper purge system at Dip Switch No. 1 on switch block S9 of the UCM. If this switch is in the ON position, the UCM is configured for the belt-driven, water-cooled purge unit. If the switch is OFF, the UCM is configured for the air-cooled, Purifier Purge. The description of operation that follows is for the Purifier Purge mode of operation.

Manual Purge Mode

If the purge switch on the chiller operating panel is positioned at MANUAL, the K9 purge relay contacts are closed continuously; this provides power through the normally-closed contacts of fault relay 3K4 to purge condensing unit 3B5 and temperature switch 3S15. When temperature switch 3S15 senses a decrease in temperature, indicating non-condensibles present in the purge tank, 3S15 normally-open contacts close which starts the pumpout cycle by supplying power to 3TB1-5.

Note: Pumpout component operation can be tested by momentarily pressing service switch 3S4 which supplies power from 3TB1-1 to 3TB1-5.

At pumpout, compressor 3B6, minute-meter 3M1 and solenoid valves 3L1 and 3L3 are energized. Power is also provided to Terminal #4 of fault timer 3DL2. The presence of power at this terminal indicates pumpout operation, so the timer begins to accumulate pumpout time. The timer will allow only a predetermined and preset amount of total pumpout time during the succeeding 24-hour period.

When the non-condensibles are adequately removed from the system, 3S15 contacts open and pumpout operation stops.

If the accumulated amount of pumpout time ever exceeds the preset amount, the timer will issue a fault signal from terminal #6, which energizes fault relay 3K4 and fault light 3DS2. The normally-closed contacts of 3K4 open, removing power from 3TB1-6 and disabling pumpout and condensing unit operation.

If an extended pumpout time is required for any reason, the fault function can be bypassed by pressing timer bypass switch 3S5 momentarily. Once this is done, the purge can be operated for a period of 24-hours without registering any pumpout time on the fault timer. When 3S5 is pressed, timer bypass light 3DS3 will light, indicating the timer is in FAULT BYPASS mode.

To reset a fault condition or timer bypass mode, the power is momentarily removed from timer (at least 1/2-second) by pressing switch 3S6.

AUTO - Automatic purge unit operation is initiated by turning the purge switch to AUTO. With the purge switch in this position, the K9 purge relay contacts close when the chiller enters a powered cooling run mode A 74. The Purifier Purge runs continuously during chiller powered cooling. The purge will shut down at the post lube cycle when the chiller is turned off.

Refrigerant Handling for Maintenance and Service

Introduction

In the past, the venting of refrigerant, both to outside atmosphere and/or to equipment room atmosphere was common practice during many standard service procedures. Today, of course, this is strictly prohibited.

The current editions of the operation and maintenance literature for Trane centrifugal chillers describe certain procedures that are no longer totally appropriate. These procedures should be modified as described below:

Purge Tank Water Removal

Part of the chiller weekly maintenance program has been inspection for and removal of water from the purge unit. The present procedure allows water and other noncondensibles to be discharged from the purge tank blowoff valve on older style purges into the equipment room. Do not vent refrigerant from the purge into the equipment room! Instead, once the purge tank is pressurized, connect an approved refrigerant containment vessel to the valve and discharge the water and refrigerant from the purge tank into the vessel.

Draining Rupture Disc Vent Line

The contents of the rupture disc/purge discharge vent line drip leg must be drained into an evacuated waste container once every six months at a minimum and more often if the purge operates excessively. Dispose of waste properly. Refer to Trane publication "CFC-GUIDE-2".

Chiller Lubrication System

Compressor Oil Change

Part of the chiller's recommended maintenance program has previously been to perform an oil change **annually**. However, new recommendations are, — to subscribe to an oil analysis program to determine the necessity to change oil, rather than change it automatically every year. This will reduce the chiller's overall lifetime oil consumption and minimize refrigerant emissions. A drain fitting should be installed in the oil line after the oil filter (Figure 17) for obtaining oil samples.

OIL CHANGE PROCEDURE:

When oil analysis indicates the need to change compressor oil, use the following procedure for removing oil:

- Draw the oil from the chiller through the oil charging valve on the chiller oil sump (Figure 17) into an approved, evacuated tank, or;
- Pump the oil from the chiller through the oil charging valve (Figure 17) into an air-tight resealable container, using a magnetically-driven auxiliary pump.

Forcing the oil from the oil sump by pressurizing the chiller (i.e., by raising chiller temperature or adding nitrogen) is NOT recommended.

Refrigerant dissolved in the oil can be removed and returned to the chiller by using an appropriate deep-vacuum recovery unit and heating/agitating the oil container. Follow all Federal, state and local regulations with regard to disposal of the waste oil.

Replacing Oil Filter

Oil filter replacement has also been an annually-recommended chiller maintenance procedure. However, current recommendations are, — to replace the filter at each oil change and more often ONLY if low oil pressure prevents unit start-up or if erratic oil pressure is experienced during chiller operation.

The traditional method of oil filter replacement involved bringing the chiller up to atmospheric pressure (unit under negative pressure), or if chiller pressure was positive, disconnecting and plugging the the filter inlet and outlet lines to prevent refrigerant escape while the filter was replaced. The correct recommendation is, — to install refrigeration ball valves on either side of the filter (Figure 17) and relocate the filter (spin-on-type only) to a horizontal position to facilitate filter removal and replacement. Later-design CVHE and CVHF units have the isolation valves factory-installed for filter replacement.

Figure 17
Schematic for Reworked CenTraVac Oil Filter Lines w/Isolation and Drain Valves

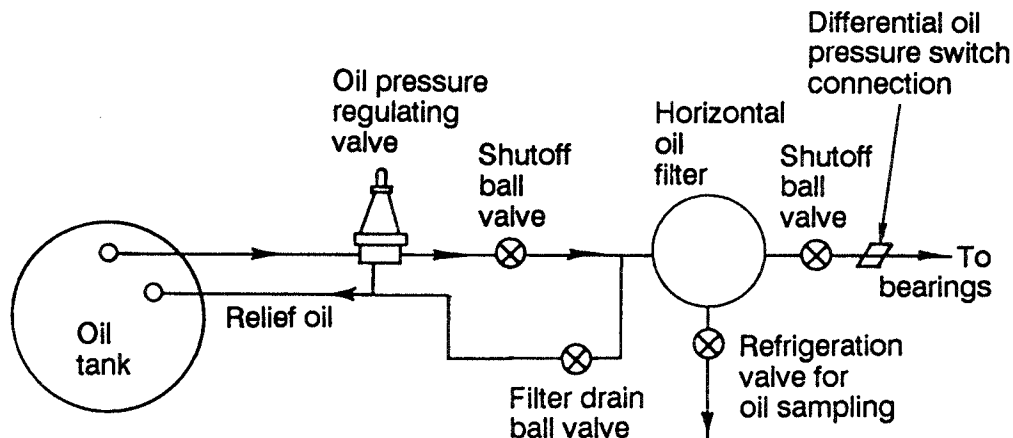

REPLACEMENT PROCEDURE:

1. Run oil pump for two to three minutes to insure that the oil filter is warmed up to oil sump temperature.
2. Close the shutoff valves before and after the filter and open the filter drain valve (Figure 17). Time required to drain oil can be reduced by momentarily opening the oil sampling drain valve (Figure 17).
3. Allow time for the filter to drain. Remove filter and place into a resealable container. Follow all federal, state and local regulations with regard to disposal of the filter.

Purge Service

Purge service instructions in the chiller maintenance literature contains procedures that recommend disassembly of the purge system while it is still pressurized with refrigerant. **THIS SHOULD NOT BE DONE!** The purge system must be valved off and evacuated before disassembly for service procedures.

Opening Chiller for Service

Any time the vacuum integrity of a chiller is broken for service procedures, the refrigerant in the chiller should be removed using appropriate recovery/recycle equipment capable of evacuation/recovery of at least 2,000 microns, normally overnight. Then, break the vacuum and repressurize to 5 psig with nitrogen. Re-evacuate to 1,000 microns and break vacuum with nitrogen again.

Turn on all available ventilation to highest speed and proceed to open unit and perform service.

WARNING! All flouorocarbon refrigerant vapors are three to five time heavier than air. Leaking vapors will collect and concentrate in confined spaces or in low spots, displacing the air, posing a potential health risk due to suffocation should a major spill occur.

Recycle/Recovery Connections

To facilitate refrigerant removal and replacement, newer-design CVHE, CVHB and all CVHF units are provided with a 3/4-inch vapor fitting with shutoff valve on the chiller suction and with a 3/4-inch liquid connection with shutoff valve at the bottom of the evaporator shell.

Leak Testing

To leak-test a chiller containing full refrigerant charge, raise chiller pressure using a controlled hot water or electric-resistance system to a maximum of 8 psig. Do not use nitrogen, which will cause excessive refrigerant discharge by the purge system.

Refrigerant Charging

The refrigerant charging procedure for Trane centrifugal chillers is:

1. If water is present in the tubes, break machine vacuum with refrigerant vapor, or circulate water, to avoid tube damage.
2. Always use refrigerant-compatible hoses or copper-tubing with self-sealing connections or shut-off valves.
3. Transfer the refrigerant using one of the following (listed in order of preference):
 - a. An approved Trane low-pressure refrigerant recovery/recycle unit.

- b. The available pressure differential.
- c. Gravity. (Use a return vent line to refrigerant drums to equalize pressure.)
- d. A mechanical gear pump with compatible seals, or a magnetically-driven pump.

4. When charging from new drums, use fitting designed for use with 3/4-inch center drum bung of 2-inch bung (Figure 18).

5. Do not use dry nitrogen to push refrigerant into the chiller as was common practice in the past. This will contaminate the charge and require excessive purging, which will result in unnecessary release of refrigerant.

6. Weigh in the proper charge.

7. Use recovery/recycle unit or vacuum pump to evacuate hoses; discharge outdoors.

Figure 18
Trane-Designed Drum Bung Fitting
w/Quick-Connect Coupling

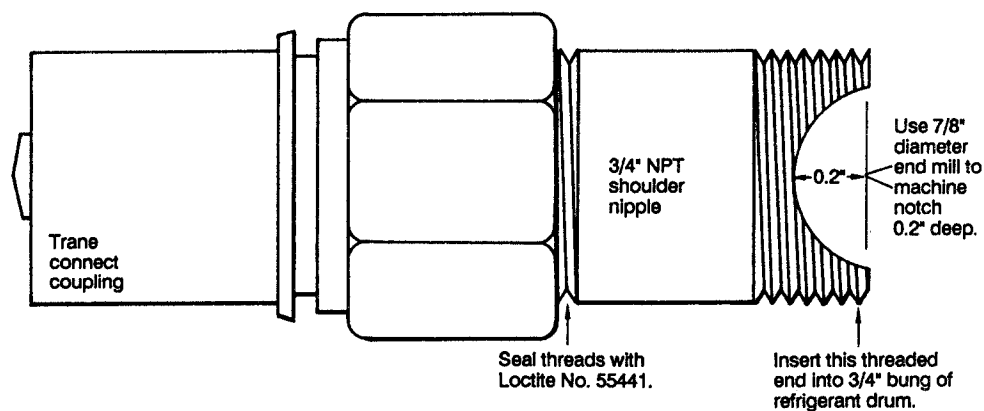



Model CVHE/CVHB/CVHF CenTraVac® Checksheet And Request For Serviceman

To: _____ Trane Service Company

Project Name: _____

The Following Items Are Being Installed And Will Be Complete By _____

1. CenTraVac:

In place and piped. Do not insulate CenTraVac or adjacent piping. The contractor is responsible for any foreign material left in the unit.

2. Piping:

- Chilled water piping connected to:
 - CenTraVac
 - Air handling units
 - Pumps
- Condenser and heat recovery condenser (as applicable) piping connected to:
 - CenTraVac
 - Pumps
 - Cooling tower
 - Heating loop
- Make-up water connected to cooling tower
- Water supply connected to filling system
- Systems filled
- Pumps run, air bled from system
- Strainers cleaned

3. Flow Balancing Valves Installed:

- Leaving chilled water
- Leaving condenser water
- Heat recovery condenser leaving water

4. Wiring:

- Compressor motor starter has been furnished by or approved by The Trane Company, La Crosse, WI
- Power available
- Interconnecting wiring, starter to control panel
- External interlock (flow switches, water pump aux., etc.)

Motors connected on:

- CenTraVac*
- Chilled water pump
- Cooling tower fan rotation checked
- Condenser water pump
- Heat recovery condenser water pump (as applicable)
- Power available for vacuum pump (115V AC)
- All controls installed and connected
- All magnetic starters installed and connected

*NOTE: Do not make final connections to compressor motor until requested by Trane Service Representative.

5. Testing:

- Dry nitrogen available for pressure testing
- Refrigerant-22 available for leak testing if necessary (25 lbs.)

6. Refrigerant On Job Site

7. Gauges, Thermometers And Air Vents

- Installed on both sides of evaporator
- Installed on both sides of condenser and heat recovery condenser (as applicable)

8. System Can Be Operated Under

- Load Conditions

9. Electrician, Control Man And Contractor's Representative Are Available To Evacuate, Charge And Test The CenTraVac Under Serviceman's Supervision

In Accordance With Your Quotation And Our Purchase Order Number _____

We Will Therefore Require Your Serviceman On The Job By** _____

This is to certify that the CenTraVac(s) has been properly and completely installed and the applicable items listed above have been completed.

**Advance notification is required to allow scheduling of the start-up as close to the requested date as possible.

1-27.08-6--(692)
Supersedes 1-27.08-6--(382)

Compliance To ASHRAE Standard 15R

- Yes No 1. Does the equipment room have a refrigerant monitor/sensor capable of monitoring and alarming within the acceptable exposure level (AEL) of the refrigerant?
- Yes No 2. Does the equipment room have an audible or visual alarm (other than the light on the monitor) which is controlled by the monitor?
- Yes No 3. Does the equipment room have mechanical ventilation?†
- Yes No 4. Is a self contained breathing apparatus available in close proximity of the equipment room?
- Yes No 5. Are the purge discharge and the rupture disk piped to the outdoors?

†The mechanical ventilation consists of two flow requirements i.e., a two-speed fan where the high speed is sized by the formula $Cfm = 100 \times$ the square root of the pounds of refrigerant of the largest chiller, and low speed is 0.5 Cfm per square foot of the equipment room space. (This requirement is for chillers located within the building which is the most common.)

Owner Awareness Of Safe Refrigerant Handling Procedures

- Yes No 1. Has the owner been fully instructed on the proper use of refrigerant 123?
- Yes No 2. Was the owner given a copy of the MSDS sheet for HCFC-123?
- Yes No 3. Was the owner given a copy of Trane publication "CFC-GUIDE-2, Refrigerant Handling Guidelines"?

Additional time required to complete the start-up and adjustment due to incompleteness of the installation will be invoiced at prevailing rates.

Checklist Completed By: _____

Signed: _____

Dated: _____

Notice To Trane Service Agency:

A copy of this completed form must be submitted to the CenTraVac Technical Service Department in La Crosse, WI prior to the actual start-up date.

1-27.08-6—(692)
Supersedes 1-27.08-6—(382)