

Group: Chiller

Part Number: 331374901

Effective: August 2005

Supersedes: OM CentrifMicro II-2

MicroTech II® Controller With Starter Information

For Centrifugal Chillers and Templifiers™
Models WSC, WDC, WCC, WPV, HSC, TSC

Software Version: WCFU3UU03P

OITS Version: 2.01.03

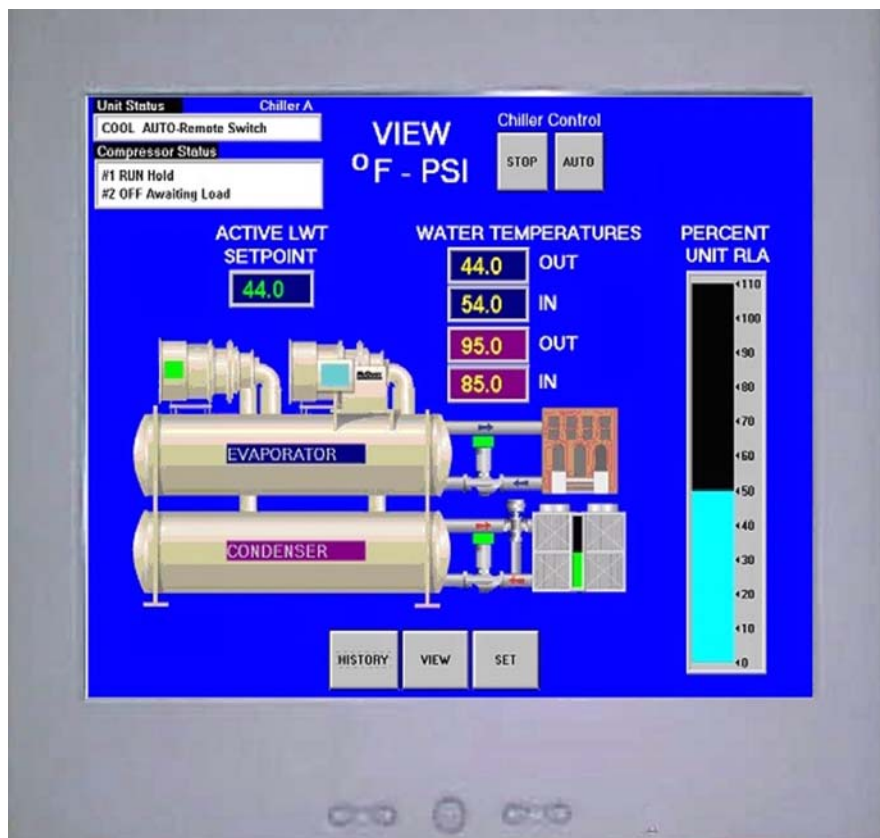

Table of Contents

Introduction.....	3	Compressor Controller.....	61
Features of the Control Panel	4	Navigating.....	61
General Description.....	5	Compressor Controller Setpoints.....	62
Component Description.....	6	Optional Starter Screens	67
Operator Interface Touch Screen	6	Low Voltage Starters, 200 – 600 Volts	68
Unit/Compressor Controller Description	6	General	68
Software	7	LED Display	69
Unit Controller	7	Faults and Alarms	74
Compressor Controller.....	8	Troubleshooting.....	77
Guardister™ Board.....	9	Preventive Maintenance.....	82
Signal Converter Board.....	9	Medium/High Voltage Starters, 2300V	
Transducer Converter Board.....	9	– 7.2KV	83
Field Wiring Diagram	10	View Parameters	84
Dual/Multi-Chiller Setup	12	Set Parameters	84
Operator Interface Touch Screen	13	Quick Start.....	86
Navigation.....	13	Troubleshooting.....	88
Screen Descriptions	15	Fault/Log Codes.....	90
VIEW Screens.....	15	LED Diagnostics.....	93
SET Screens.....	21	Preventive Maintenance.....	93
SERVICE Screen	35	Sequence of Operation	94
HISTORY Screens	36	Thermal Expansion Valve, Models 079 - 126.....	94
Download from the USB.....	37	Electronic Expansion Valve, Models 050 - 063 ...	96
ACTIVE ALARM Screen.....	38	Operating the Chiller Control System...97	
Unit Controller	42	Interface Panel On/Off.....	97
Navigating.....	42	Start/Stop Unit	97
Screen Descriptions	46	Change Setpoints	98
SET Screens	49	Alarms	98
Unit Controller Setpoints	51	Control Component Failure	98



ETL applies only to models
WSC, WDC, WCC, WPV

Manufactured in an ISO certified facility.

McQuay" and MicroTech II are registered trademarks of McQuay International
©2005 McQuay International

"Illustrations and information cover McQuay International products at the time of publication and we reserve the right to make changes in design and construction at anytime without notice."

Introduction

This manual provides operating, maintenance and troubleshooting information for McQuay centrifugal chillers with MicroTech II™ control and for the majority of starters used on McQuay centrifugal chillers.

Software Version

Software Code: WCFU3UU03P, adds Unit Set Screen 15, for electronic expansion valve.

BOOT: 3.0F

BIOS: 3.56



WARNING

Electric shock hazard. Can cause personal injury or equipment damage. This equipment must be properly grounded. Connections to and service of the MicroTech control panel must be performed only by personnel that are knowledgeable in the operation of the equipment being controlled.



CAUTION

Static sensitive components. A static discharge while handling electronic circuit boards can cause damage to the components. Discharge any static electrical charge by touching the bare metal inside the control panel before performing any service work. Never unplug any cables, circuit board terminal blocks, or power plugs while power is applied to the panel.

NOTICE

This equipment generates, uses and can radiate radio frequency energy and, if not installed and used in accordance with this instruction manual, may cause interference to radio communications. Operation of this equipment in a residential area is likely to cause harmful interference in which case the user will be required to correct the interference at his own expense. McQuay International Corporation disclaims any liability resulting from any interference or for the correction thereof.



CAUTION

Do not install any non-McQuay authorized software or alter operating systems in any unit microprocessor, including the interface panel. Failure to do so can cause malfunction of the control system and possible equipment damage.

Temperature and Humidity Limits

The MicroTech II controller is designed to operate within an ambient temperature range of 20°F to 130°F (-7°C to 54°C) with a maximum relative humidity of 95% (non-condensing).

Features of the Control Panel

- Control of leaving chilled water within a $\pm 0.5^{\circ}\text{F}$ ($\pm 0.3^{\circ}\text{C}$) tolerance. Systems with a large water volume and relatively slow load changes can do better.
- Readout of the following temperature and pressure readings:
 - Entering and leaving chilled water temperature
 - Entering and leaving condenser water temperature
 - Saturated evaporator refrigerant temperature and pressure
 - Saturated condenser temperature and pressure
 - Suction line, liquid line and discharge line temperatures - calculated superheat for discharge and suction lines – calculated subcooling for liquid line
 - Oil sump temperature - oil feed temperature and pressure
 - Optional condenser heat recovery temperature
- Automatic control of primary and standby evaporator and condenser pumps.
- Control of up to 4 stages of cooling tower fans plus modulating bypass valve and/or tower fan VFD.
- The controller will store and display key historic operating data for recall in a graphic format on the screen. Data can also be exported for archival purposes via a USB port.
- Three levels of security protection against unauthorized changing of setpoints and other control parameters.
- Warning and fault diagnostics to inform operators of warning and fault conditions in plain language. All warnings, problems and faults are time and date stamped so there is no guessing of when the fault condition occurred. In addition, the operating conditions that existed just prior to shutdown can be recalled to aid in isolating the cause of the problem.
- Twenty-five latest faults are displayed on the unit controller, eight can be displayed on the touch screen. Data can be exported for archival purposes via a 3.5-inch floppy drive.
- Soft loading feature reduces electrical consumption and peak demand charges during loop pulldown.
- Adjustable load pull-down rate reduces under-shoot during loop pulldown.
- Remote input signals for chilled water reset, demand limiting, unit enable.
- Manual control mode allows the service technician to command the unit to different operating states. Useful for system checkout.
- BAS communication capability via LONMARK®, Modbus® or BACnet® standard protocols for BAS manufacturers.
- Service Test mode for troubleshooting controller hardware.
- Pressure transducers for direct reading of system pressures. Preemptive control of high motor amps, low evaporator pressure conditions and high discharge temperature takes corrective action prior to a fault trip.

General Description

General Description

The centrifugal MicroTech II control system consists of microprocessor-based controllers that provide all monitoring and control functions required for the controlled, efficient operation of the chiller. The system consists of the following components:

- Operator Interface Touch Screen (OITS), one per unit-provides unit information and is the primary setpoint input instrument. It has no control function.
- Unit Controller, one per chiller-controls unit functions and communicates with all other controllers. It is the secondary location for setpoint input if the Interface Screen is inoperative. It is located in a panel adjacent to the OITS.
- Compressor Controller for each compressor on a chiller-controls compressor functions and can operate a compressor without the unit controller or Operator Interface Panel. The controller is located in a panel adjacent to the compressor.

The operator can monitor all operating conditions by using the unit-mounted OITS. In addition to providing all normal operating controls, the MicroTech II control system monitors equipment protection devices on the unit and will take corrective action if the chiller is operating outside of its normal design conditions. If a fault condition develops, the controller will shut the compressor or entire unit down and activate an alarm output. Important operating conditions at the time an alarm condition occurs are retained in the controller's history log to aid in troubleshooting and fault analysis.

The system is protected by a password scheme that only allows access by authorized personnel. The operator must enter the password into the touch screen (or one of the controller's keypad) before any setpoints can be altered.

NOTE: It is important to understand that the OITS is the operator interface device under normal conditions. If, and only if, it is unavailable, the unit controller can be used to operate the chiller. Furthermore, if the unit controller is unavailable, the compressor controller(s) will still operate the compressors and try to maintain chilled water temperature. Certain data and operability will not be available under either of these operating modes. If the Microtech II controller controls the tower and system pumps, they will have to run manually during this emergency situation.

Control Architecture

Figure 1, Major Control Components

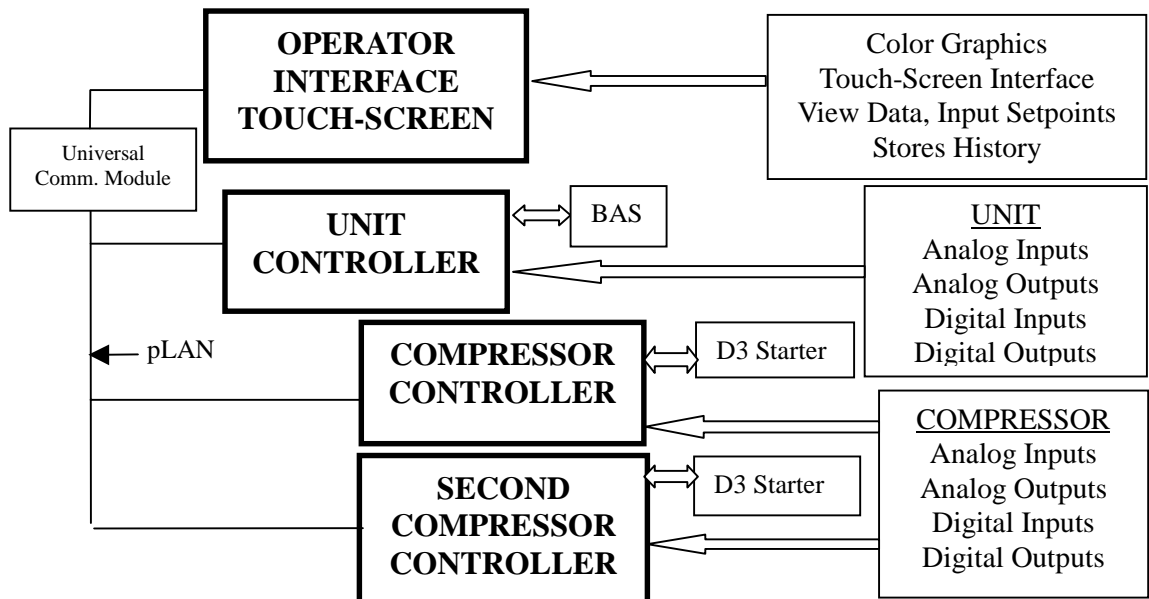

Component Description

Operator Interface Touch Screen

The operator interface touch screen (OITS) is the primary device by which commands and entries into the control system are made. It also displays all controller data and information on a series of graphic screens. A single OITS is used on both single and dual compressor units.

The control panel contains a USB port that can be used for loading information to and from the controller system.

The OITS panel is mounted on a moveable arm to allow placement in a convenient position for the operator.

There is a screen-saver programed into the system. The screen is reactivated by touching it anywhere.



Unit/Compressor Controller Description

Hardware Structure

The controller is fitted with a 16-bit microprocessor for running the control program. There are terminals for connection to the controlled devices (for example: solenoid valves, tower fans, pumps). The program and settings are saved permanently in FLASH memory, preventing data loss in the event of power failure without requiring a back-up battery.

The controller connects to other controllers and the OITS via a local communications network (p-LAN). It also has remote communication access capability for BAS interface.

Keypad

A 4 line by 20 character/line liquid crystal display and 6-button keypad is mounted on the unit and compressor controllers. Its layout is shown below.

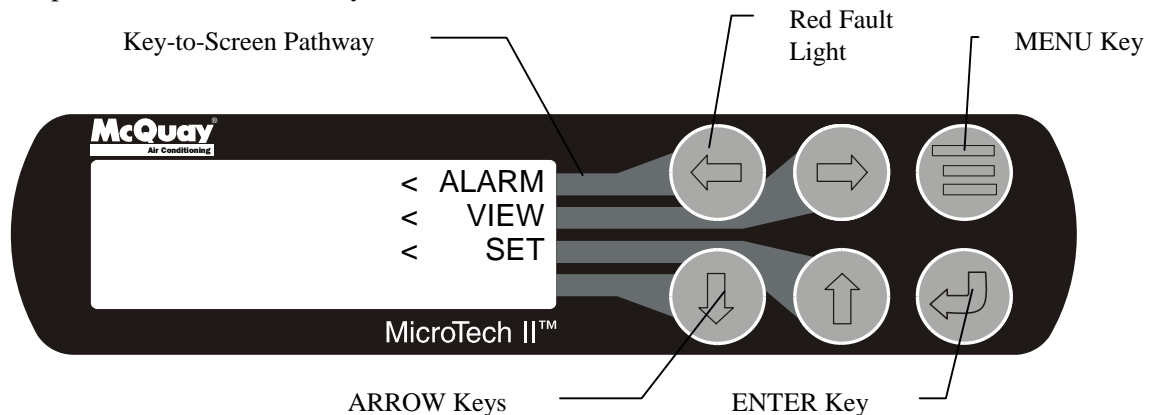

The four arrow keys (UP, DOWN, LEFT, RIGHT) have three modes of use.

- Scroll between data screens in the direction indicated by the arrows (default mode).
- Select a specific data screen in the menu matrix using dynamic labels on the right side of the display such as ALARM, VIEW, etc (this mode is entered by pressing the MENU key). For ease of use, a pathway connects the appropriate button to its respective label on the screen.
- Change field values in setpoint programming mode according to the following table:

LEFT key = Default	RIGHT key = Cancel
UP key = Increase (+)	DOWN key = Decrease (-)

These four programming functions are indicated by one-character abbreviation on the right side of the display. This programming mode is entered by pressing the ENTER key.

Software

The same model controller is used as either a unit controller or a compressor controller. The controller operation is determined by the setting of the DIP switches located on the upper-left front of the control, which establish the controllers pLAN address. For unit controller operation (one chiller in system), number 1 and 3 switches are up (ON) and the balance are down (OFF). Compressor controller operation is number 1 up and the balance down. On dual units, the second compressor has number 2 up and the balance down. These settings are all made in the factory during unit testing. Settings are different with multiple chillers and will be set by the startup technician.

The operating software is revised occasionally. The version residing in a given control is identified on the screen at boot-up or can be viewed at any time by pressing the Right and Up Arrows simultaneously. It is also displayed on the OITS SERVICE screen.

Unit Controller

There is one unit controller mounted on the chiller that serves both compressor units.

Unit and compressor on/off switches are mounted in the unit controller panel located adjacent to the OITS panel. They are designated 1 for on and O for off. The compressor on/off switch should only be used when an immediate stop is required since the normal shut down sequence is bypassed.

The switch panel also has a circuit breaker that interrupts power to the cooling tower fans, valves and evaporator and condenser pumps, if any of these are tied into the MicroTech II for control of their operation. If these components operate independently from the chiller control, the breaker has no effect.

There is an emergency shutdown switch located on the left outside of the panel that causes an immediate shutdown of both compressors.

The unit controller's primary function is processing data relating to the entire chiller *unit* operation, as compared to data relating to the *compressor* operation. The unit controller processes information and sends data to other controllers and devices and relays information to the OITS for graphic display. It has a 4x20 LCD display and keys for accessing data and changing setpoints. The LCD can display most of the same information as the OITS and can operate the chiller independently if the OITS is not available. Inputs and outputs are shown in the following tables.

Table 1, Unit Controller, Analog Inputs

#	Description	Signal Source	Range
B1	Reset of Leaving Water Temperature	4-20 mA Current	0-(10 to 80°F)
B2	Entering Evaporator Water Temperature	NTC Thermister (10k@25°C)	-58 to 212°F
B3	Entering Condenser Water Temperature	NTC Thermister (10k@25°C)	-58 to 212°F
B4	Leaving Condenser Water Temperature	NTC Thermister (10k@25°C)	-58 to 212°F
B5	Liquid Line Refrigerant Temperature	NTC Thermister (10k@25°C)	-58 to 212°F
B6	Demand Limit	4-20 mA Current	0-100 %RLA
B7	Evaporator Water Flow	4 to 20 mA Current	0 to 10,000 gpm
B8	Condenser Water Flow	4 to 20 mA Current	0 to 10,000 gpm
B9	Entering Heat Recovery Temp.	NTC Thermister (10k@25°C)	-58 to 212°F
B10	Leaving Heat Recovery Temperature	NTC Thermister (10k@25°C)	-58 to 212°F

Table 2, Unit Controller, Digital Inputs

#	Description	Signal	Signal
ID1	Unit OFF Switch	0 VAC (Stop)	24 VAC (Auto)
ID2	Remote Start/Stop	0 VAC (Stop)	24 VAC (Start)
ID3	Mode Switch	0 VAC (Cool)	24 VAC (Ice or Heat)

Table 3, Unit Controller, Digital Outputs

#	Description	Load	Output OFF	Output ON
NO1	Primary Evaporator Water Pump	Pump Contactor	Pump OFF	Pump ON
NO2	Standby Evaporator Water Pump	Pump Contactor	Pump OFF	Pump ON
NO3	Primary Condenser Water Pump	Pump Contactor	Pump OFF	Pump ON
NO4	Standby Condenser Water Pump	Pump Contactor	Pump OFF	Pump ON
NO5	Tower Fan #1	Fan Contactor	Fan OFF	Fan ON
NO6	Tower Fan #2	Fan Contactor	Fan OFF	Fan ON
NO7	(unused)			
NO8	Alarm	Alarm Indicator	Alarm OFF	Alarm ON
NO9	Tower Fan #3	Fan Contactor	Fan OFF	Fan ON
NO10	Tower Fan #4	Fan Contactor	Fan OFF	Fan ON

Table 4, Unit Controller, Analog Outputs

#	Description	Output Signal	Range
Y1	Cooling Tower Bypass Valve Position	0 to 10 VDC	0 to 100% Open
Y2	Cooling Tower VFD Speed	0 to 10 VDC	0 to 100%
Y3	Electronic Expansion Valve (EEV)	0 to 10 VDC	0 to 100% Open

Compressor Controller

The compressor controller's primary function is controlling and protecting the compressor. No setpoint inputs are made with it. There is one compressor controller for each compressor on a dual chiller unit. The compressor controller receives, processes, and sends data to other controllers and devices and to the compressor starter or variable frequency drive (VFD). With some operator intervention the compressor controller can operate the compressor(s) if the unit controller and/or the operator interface touch screen are unavailable. Inputs and outputs are as follows:

Table 5, Compressor Controller, Analog Inputs

#	Description	Signal Source	Range
B1	Oil Sump Pressure	0.5 to 4.5 VDC	0 to 150 psi
B2	Oil Supply Pressure to Compressor	0.5 to 4.5 VDC	0 to 450 psi
B3	Evaporator Refrigerant Pressure	0.1 to 0.9 VDC	0 to 150 psi
B4	Oil Sump Temperature	NTC Thermister (10k@25°C)	-58 to 212°F
B5	Compressor Suction Temperature	NTC Thermister (10k@25°C)	-58 to 212°F
B6	Condenser Refrigerant Pressure	0.5 to 4.5 VDC	0 to 450 psi
B7	Compressor Discharge Temperature	NTC Thermister (10k@25°C)	-58 to 212°F
B8	Motor Current	0.5 to 4.5 VDC	0 to 125% RLA
B9	Oil Feed Temperature	NTC Thermister (10k@25°C)	-58 to 212°F
B10	Leaving Evaporator Water Temperature	NTC Thermister (10k@25°C)	-58 to 212°F

Table 6, Compressor Controller, Digital Inputs

#	Description	Signal	Signal
ID1	Manual Off	0 VAC (Off)	24 VAC (Auto)
ID2	Mech High Pressure	0 VAC (High Pressure)	24 VAC (OK)
ID3	Motor High Temperature	0 VAC (High Temp)	24 VAC (OK)
ID4	Vanes Closed Switch	0 VAC (Not Closed)	24 VAC (Closed)
ID5	Starter Transition	0 VAC (No Transition)	24 VAC (Transition)
ID6	Starter Fault	0 VAC (Fault)	24 VAC (No Fault)
ID7	Evap Flow	0 VAC (NO Flow)	24 VAC (Flow)
ID8	Cond Flow	0 VAC (NO Flow)	24 VAC (Flow)
ID9	Vanes Open Switch	0 VAC (Not Open)	24 VAC (Open)

Table 7, Compressor Controller, Analog Outputs

#	Description	Output Signal	Range
Y1	Compressor VFD Speed	0 to 10 VDC	0 to 100%
Y2	Open		
Y3	Oil Cooler	0 to 10 VDC	0 to 100%
Y4	Hot Gas Bypass	0 to 10 VDC	0 to 100%

Table 8, Compressor Controller, Digital Outputs

#	Description	Load	Output OFF	Output ON
NO1	Motor Control Relay	Starter	Compressor OFF	Compressor ON
NO2	Hot Gas Bypass	Solenoid	No Bypass	Bypass
NO3	Liquid Injection	Solenoid	No Injection	Injection
NO4	Oil Pump	Pump Contactor	Pump OFF	Pump ON
NO5	Oil Sump Heater	Heater	Heater OFF	Heater ON
NO6	Oil Cooler	Solenoid	Cooling OFF	Cooling ON
NO7	Vane Pulse	Solenoid	Hold	Move Vanes
NO/C8	Load/Unload	Solenoid	Unload	Load

Guardister™ Board

The Guardister board monitors the motor winding temperature through embedded Guardistor temperature sensors in the motor. If the motor temperature rises to an unsafe level, the board will signal the compressor controller and the compressor will shut down.

Signal Converter Board

On medium voltage starters, the AC current signal generated by the starter is converted by the separate signal board into a 0-5 VDC signal that is directly proportional to the compressor motor amp draw. The amp draw signal is sent to the compressor controller.

On low voltage starters, the D3 starter feature eliminates the need for this board.

Transducer Converter Board

The transducer converter board converts the pressure transducer signal to the correct voltage signal and relates it to the compressor controller.

Field Wiring Diagram

NOTES for Following Wiring Diagram

1. Compressor motor starters are either factory mounted and wired, or shipped separate for field mounting and wiring. If provided by others, starters must comply with McQuay specification 359AB99. All line and load side power conductors must be copper.
2. If starters are freestanding, then field wiring between the starter and the control panel is required. Minimum wire size for 115 Vac is 12 GA for a maximum length of 50 feet. If greater than 50 feet, refer to McQuay for recommended wire size minimum. Wire size for 24 Vac is 18 GA. All wiring to be installed as NEC Class 1 wiring system. All 24 Vac wiring must be run in separate conduit from 115 Vac wiring. Main power wiring between starter and motor terminal is factory-installed when units are supplied with unit-mounted starters. Wiring of free-standing starter must be wired in accordance with NEC and connection to compressor motor terminals must be made with copper wire and copper lugs only.
3. For optional sensor wiring, see unit control diagram. It is recommended that dc wires be run separately from 115 Vac wiring.
4. Customer furnished 24 or 120 Vac power for alarm relay coil can be connected between UTB1 terminals 84 power and 51 neutral of the control panel. For normally open contacts, wire between 82 & 81. For normally closed contacts, wire between 83 & 81. The alarm is operator programmable. The maximum rating of the alarm relay coil is 25 VA.
5. Remote on/off control of unit can be accomplished by installing a set of dry contacts between terminals 70 and 54.
6. Evaporator and condenser paddle type flow switches or water pressure differential switches are required and must be wired as shown. WDC dual compressor units require DPDT switches. If field supplied pressure differential switches are used then these must be installed across the vessel and not the pump.
7. Customer supplied 115 Vac, 20 amp power for optional evaporator and condenser water pump control power and tower fans is supplied to unit control terminals (UTBI) 85 power / 86 neutral, PE equipment ground.
8. Optional customer supplied 115 Vac, 25 VA maximum coil rated chilled water pump relay (EP 1 & 2) can be wired as shown. This option will cycle the chilled water pump in response to building load.
9. The condenser water pump must cycle with the unit. A customer supplied 115 Vac 25 VA maximum coil rated condenser water pump relay (CP1 & 2) is to be wired as shown.
10. Optional customer supplied 115 Vac, 25 VA maximum coil rated cooling tower fan relays (CL - C4) can be wired as shown. This option will cycle the cooling tower fans in order to maintain unit head pressure.
11. Auxiliary 24 Vac rated contacts in both the chilled water and condenser water pump starters must be wired as shown.
12. For VFD, Wye-Delta, and solid state starters connected to six (6) terminal motors. The conductors between the starter and motor carry phase current and selection shall be based on 58 percent of the motor rated load amperes (RLA). Wiring of free-standing starter must be in accordance with the NEC and connection to the compressor motor terminals shall be made with copper wire and copper lugs only. Main power wiring between the starter and motor terminals is factory-installed when chillers are supplied with unit-mounted starters.
13. Optional Protocol Selectability BAS interfaces. The locations and interconnection requirements for the various standard protocols are found in their respective installation manuals, obtainable from the local McQuay sales office and also shipped with each unit:
Modbus IM 743-0 LONWORKS IM 735-0 BACnet IM 736-0
14. The "Full Metering" or "Amps Only Metering" option will require some field wiring when free-standing starters are used. Wiring will depend on chiller and starter type. Consult the local McQuay sales office for information on specific selections.

Figure 2, Field Wiring Diagram

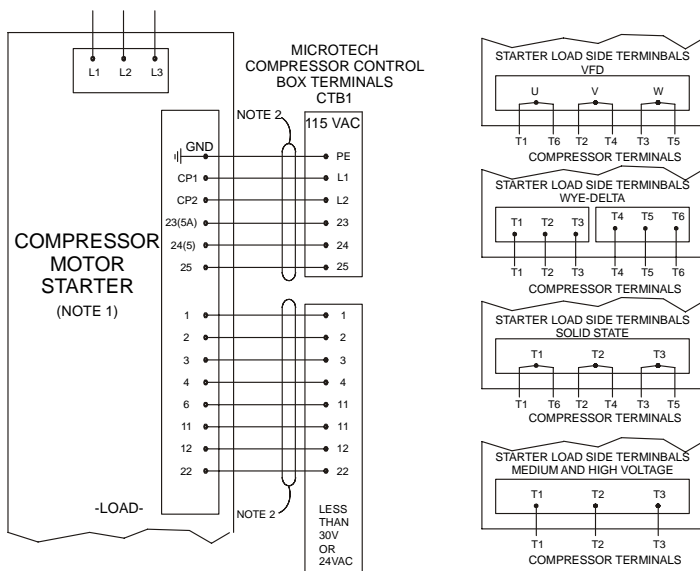
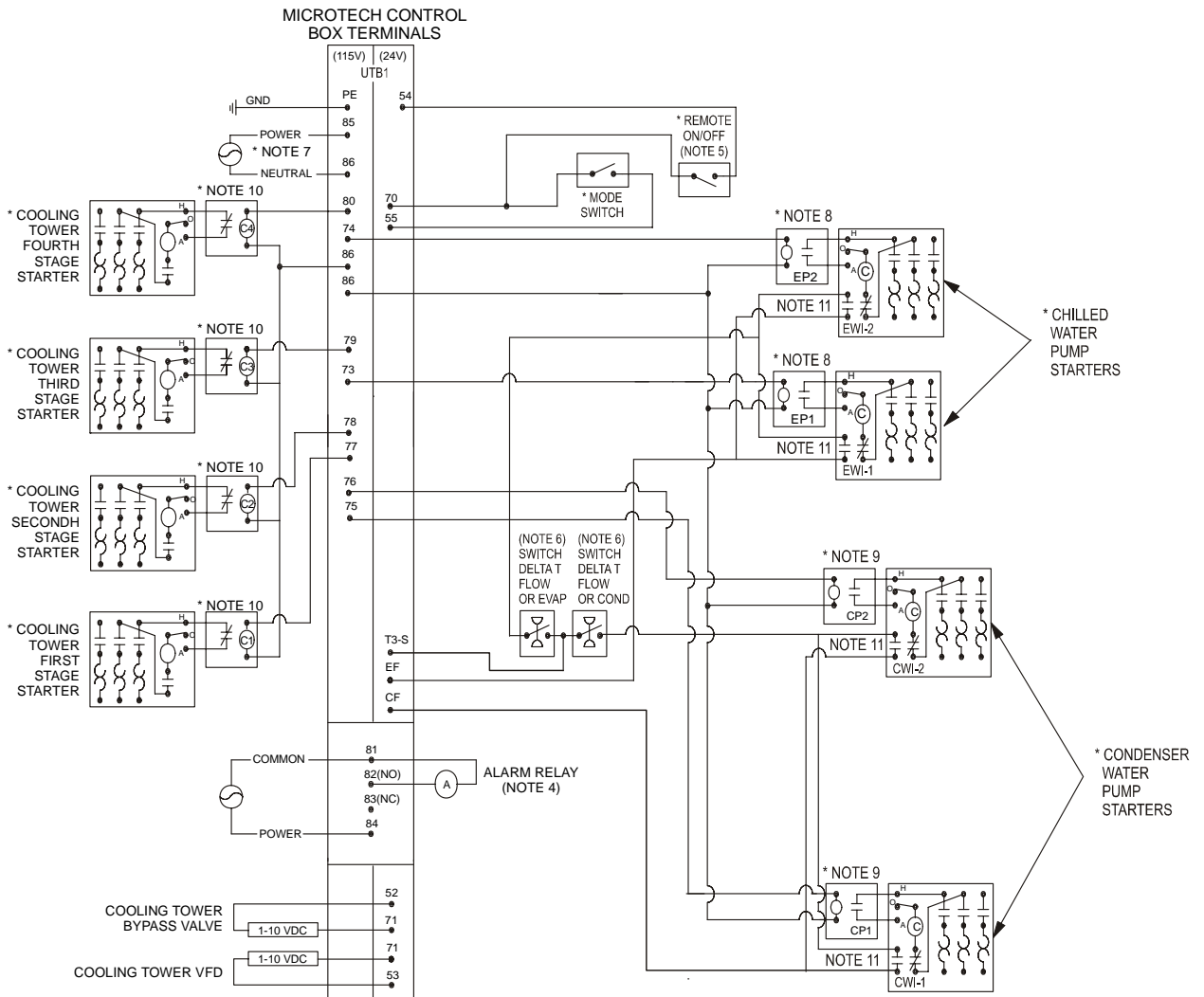

- FOR DC VOLTAGE AND 4-20 MA CONNECTIONS (SEE NOTE 3)
- FOR DETAILS OF CONTROL REFER TO UNIT CONTROL SCHEMATIC 330342101
- COMPRESSOR CONTROL SCHEMATIC 330342201
- LEGEND: 330343001
- * FIELD SUPPLIED ITEM

NOTE 12

330387901-0A

NOTE: See notes on previous page.

Dual/Multi-Chiller Setup

Component Description

Table 9, Address DIP switch settings for controllers using pLAN.

Chiller (1)	Comp 1	Comp 2	Unit Controller	Reserved	Operator Interface (2)	Reserved
A	1	2	5	6	7	8
	100000	010000	101000	011000	111000	000100
B	9	10	13	14	15	16
	100100	010100	101100	011100	111100	000010
C	17	18	21	22	23	24
	100010	010010	101010	011010	111010	000110

NOTES:

- Up to three single or dual compressors can be interconnected.
- The interface setting is not a DIP switch setting. The 'Operator Interface Touch Screen' (OITS) address is selected by selecting the 'service' set screen. Then, with the Technician level password active, select the 'pLAN Comm' button. Buttons A(7), B(15), C(23), D(31) will appear in the middle of the screen, then select the letter for the OITS address for the chiller that it is on. Then close the screen. Note that A is the default setting from the factory.
- Six Binary Switches: Up is 'On', indicated by '1'. Down is 'Off', indicated by '0'. For example, chiller A, compressor 2, has the second switch up and the balance down.

Operator Interface (OITS) Settings

Settings for any type of linked multiple compressor operation must be made to the MicroTech II controller. Settings on a dual compressor unit are made in the factory prior to shipment, but must be verified in the field before startup. Settings for multiple chiller installations are set in the field on the Operator Interface Touch Screen as follows:

Maximum Compressors ON – SETPOINTS - MODES screen, Selection #10 = 2 for a dual, 4 for 2 duals, 3 for three separate, single compressor chillers, etc. See page 33 for details.

Sequence and Staging – SETPOINTS - MODES screen, Selection #11 & #13; #12 & #14. Sequence sets the sequence in which compressors will start. Setting all to "1" evokes the automatic lead/lag feature and is the preferred setting. See page 33 for further details.

Nominal Capacity – SETPOINTS - MOTOR screen, Selection #10. The setting is the compressor design tons. Compressors on dual units are always of equal capacity. See page 32 for further details.

pLAN Setup

- With no pLAN connections between chillers, disconnect control power and set the DIP switches as shown in Table 9.
- With all manual switches off, turn on control power to each chiller and set each OITS address (see Note 2 above).
- Verify correct nodes on each OITS Service Screen.
- Connect chillers together (pLAN), RS 485, between J6 connections on each unit's isolation boards (field supplied).
- Verify correct nodes on each OITS Service Screen

Operator Interface Touch Screen

Navigation

The home screen shown in VIEW screen on page 15 is usually left on (there is a screen-saver built in that is reactivated by touching the screen anywhere). This VIEW screen contains the STOP and AUTO buttons used to start and stop the unit when in Local control. Other groups of screens can be accessed from the Home screen by pressing one of three buttons on the bottom of the screen; HISTORY, VIEW, SET.

- HISTORY will go to the last history screens viewed and can toggle between the two history screens.
 - Trend History
 - Alarm History
- VIEW will go to the next View screen and other sub-View screens used to look in detail at settings and the operation of the chiller. Pressing View from any other screen will return to the Home View screen.
- SET will go to a series of screens used to set setpoints.

The figure on the following page illustrates the arrangement of the various screens available on the OITS. A few minutes practice on an actual OITS should provide a comfortable level of confidence in navigating through the screens.

Figure 3, OTIS Screen Layout

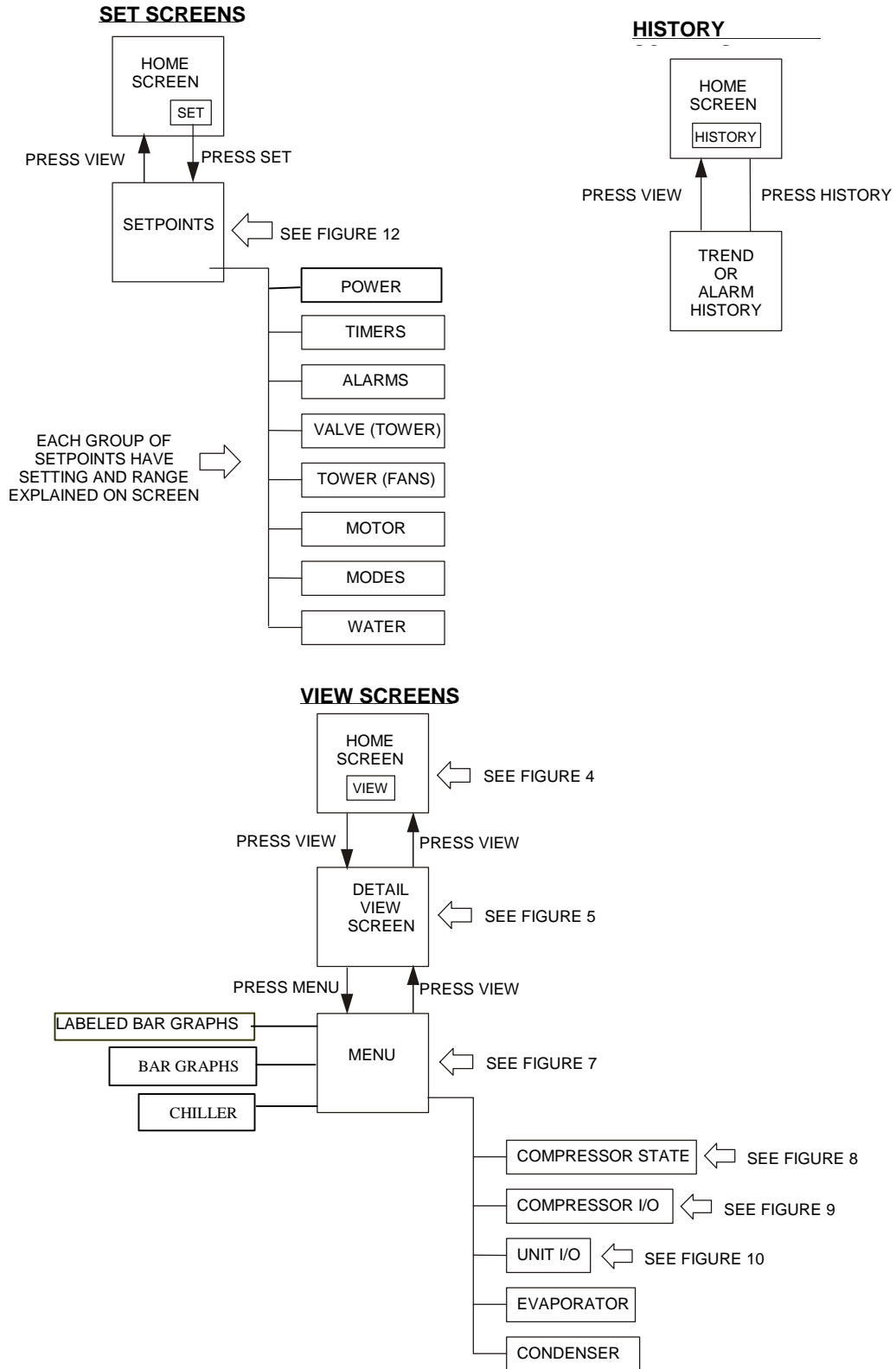

Pressing VIEW from any sub-menu will toggle back to the home screen.
 Pressing MENU when in any sub-menu will return to the view screen.
 Pressing SET or HISTORY will go to these groups of menus.

Screen Descriptions

VIEW Screens

View screens are used for looking at unit status and conditions.

Figure 4, Home View Screen, Dual Compressor Unit

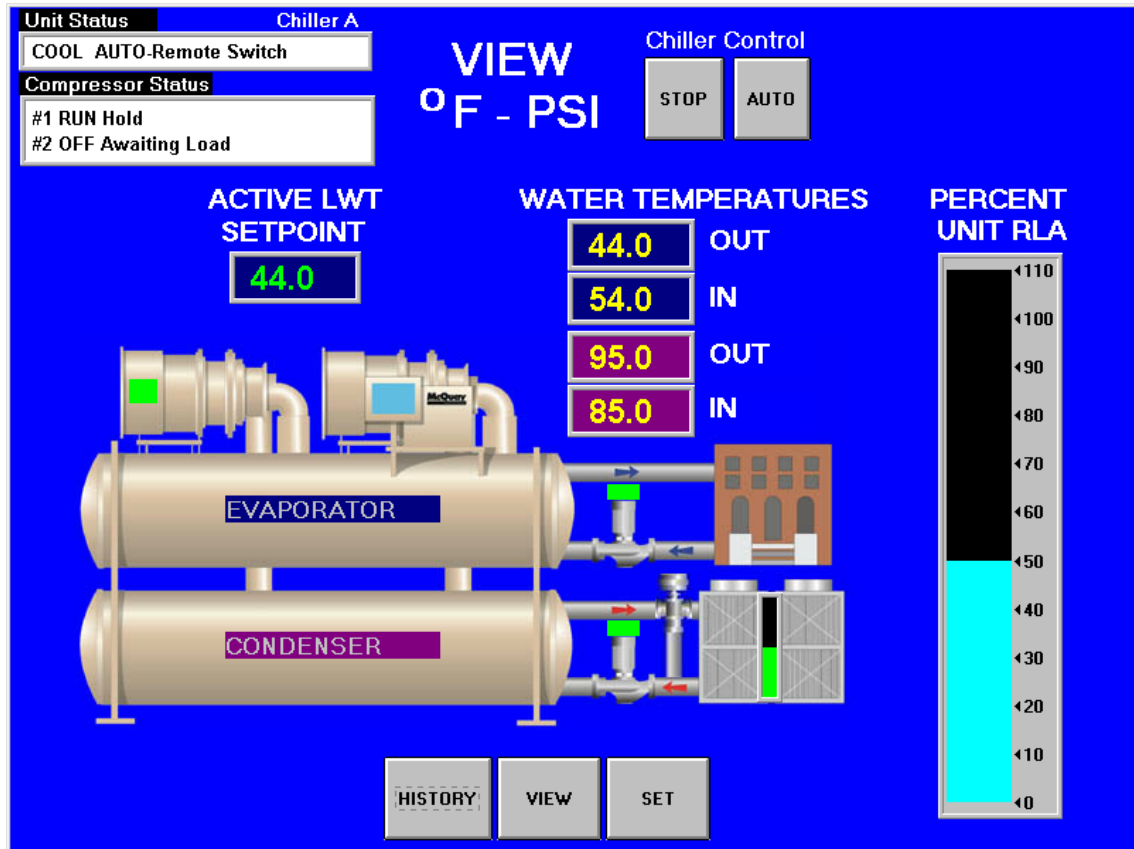

Home View Screen

The Home View Screen shows the basic condition of the chiller and is the screen that is normally left on. Dual compressor units (WDC) will show two compressors and the status of both. Single Compressor units (WSC) will show only the one compressor. The pressures and temperatures shown are common to the unit and correct for both single and dual compressor chillers. Superimposed on a chiller schematic is:

Information

- Active chilled water setpoint
- Entering and leaving chilled water temperatures
- Entering and leaving condenser water temperatures
- Percent motor amps
- UNIT STATUS is MODE followed by STATE followed by the SOURCE that is the device or signal that created the STATE. The possible combinations are in the following table:

Table 10, UNIT STATUS Combinations

MODE	STATE	SOURCE
COOL	OFF	Manual Switch
ICE	SHUTDOWN (Note 1)	Remote Switch
HEAT	AUTO	Local
		BAS Network
TEST		

Note: Shutdown is the state of shutting down; vane close, postlube, etc.

- COMPRESSOR STATUS is MODE followed by STATE followed by the SOURCE that is the device or signal that created the STATE. The possible combinations are in the following table

Table 11, COMPRESSOR STATUS Possibilities

Complete STATUS Text (in priority sequence)	Notes
OFF Manual Switch	Reason for the compressor being off.
OFF Compressor Alarm	
OFF Unit State	
OFF Evap Flow/Re-circulate	
OFF Low Oil Sump Temp	
OFF Start to Start Timer=xxx	
OFF Stop to Start Timer=xxx	
OFF Staging (Next ON)	
OFF Awaiting Load	
PRELUBE Vanes Open	Current state of the Prelube sequence
PRELUBE Timer=xxx	
PRELUBE Condenser Flow	
RUN Unload Vanes-Max Amps	Overrides water temperature command
RUN Hold Vanes-Max Amps	
RUN Manual Vanes & Speed	Used for service purposes. "T" password required. Operated from compressor controller
RUN Load Vanes-Manual Speed	
RUN Hold Vanes-Manual Speed	
RUN Unload Vanes-Manual Speed	
RUN Load Speed-Manual Vanes	
RUN Hold Speed-Manual Vanes	
RUN Unload Speed-Manual Vanes	
RUN Unload Vanes-Lag Start	Overrides water temperature command
RUN Hold Vanes-Evap Press	
RUN Unload Vanes-Evap Press	
RUN Unload Vanes-Soft Load	
RUN Hold Vanes-Soft Load	
RUN Load Vanes-Disch Temp	
RUN Hold Vanes-Pull-down Rate	
RUN Unload Vanes-Demand Limit	
RUN Hold Vanes-Min Amps	
RUN Load Vanes	
RUN Hold Vanes	
RUN Unload Vanes	
SHUTDOWN Unload	Unloading during the shutdown sequence
POSTLUBE Timer=xxx	Postlube timer on
POSTLUBE Motor Current High	Compressor motor running during the shutdown mode. It should be off.

NOTES:

1. Timer countdown values will be shown where "(xxx)" is shown below.
2. For a VFD equipped compressor, "Vanes" or "Speed" is shown in the RUN state to indicate if the capacity is controlled by speed from the VFD or by vane control.
3. When the compressor is in the START state (oil pump started but still waiting for oil pressure), "PRELUBE – Vanes Open" or "PRELUBE – Timer=(xxx)" is shown as appropriate.

Action Buttons for:

- AUTO and STOP buttons, normal start (AUTO) and STOP button activates the normal start and shutdown sequence. These buttons are only active when the control is in the "Local Control" mode. This eliminates the possibility of inadvertently shutting off the unit locally when it is under control of a remote signal such as a BAS.
- HISTORY, toggles between the Trend History screen and the Alarm History screen.
- SET, toggles between the Set Points screen that are used for changing setpoints and the Service screen.

Returning

Pressing the VIEW button from any screen will return to the HOME VIEW screen.

Figure 5, Detail View Screen

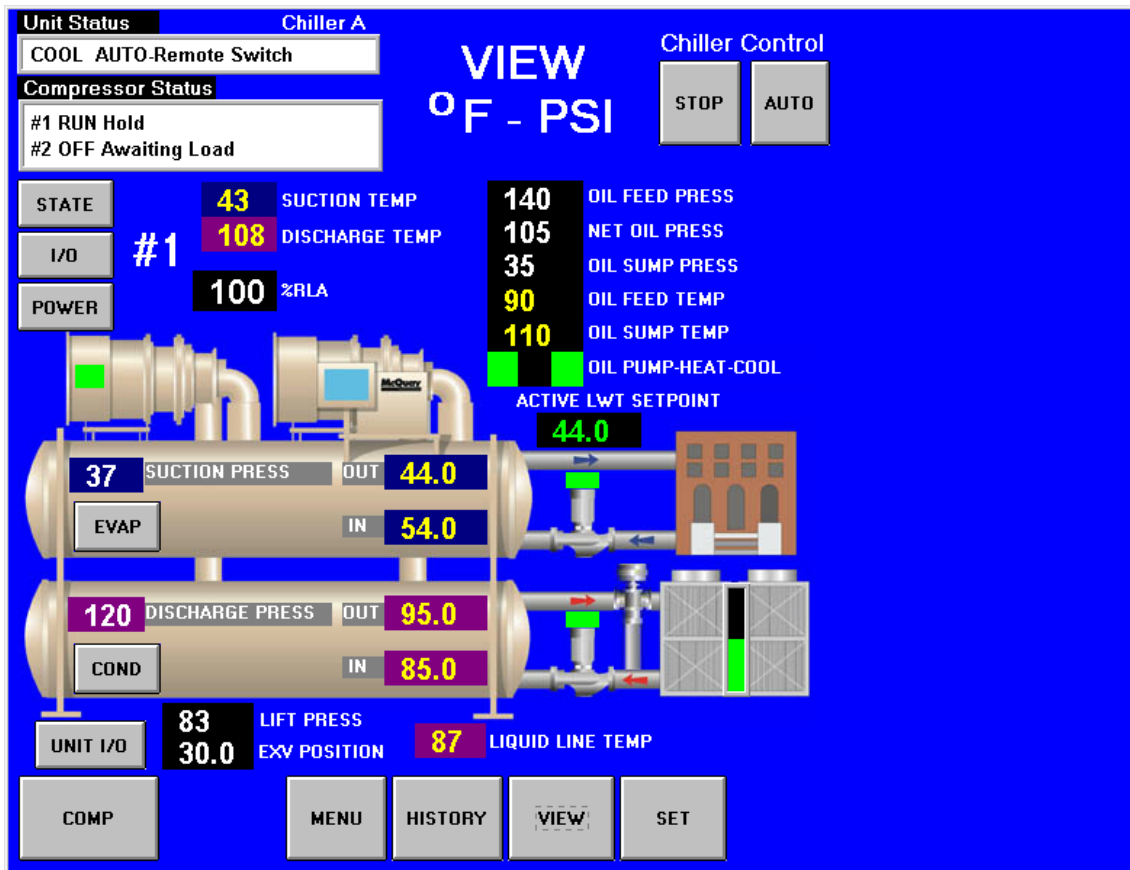

Pressing the VIEW button on the bottom of the Home View screen (Figure 4) accesses the Detail View Screen shown above. This screen gives additional information on the refrigerant pressures and temperatures and lubricant data.

Pressing the STATE button will bring up a display of the compressor state as described in Figure 8 on page 19.

Pressing the I/O button displays the status of the compressor inputs and outputs as described on page 20. Dual compressor units will have a COMP button that will toggle between the two compressors' data, allowing the STATE and I/O detail screens to be viewed for either compressor.

On WCC dual, counterflow chillers, compressor #1 is the lag compressor, it sees the entering chilled water and is the last on, first off. Compressor #2 produces the leaving chilled water and is the first on, last off.

Pressing the UNIT I/O button displays the unit inputs and outputs as described in Figure 10 on page 1.

Pressing the EVAP or COND button will give detailed information on the evaporator or condenser pressures and temperatures.

Pressing the MENU button on the bottom of the screen will go to a menu (see Figure 7) from which the above listed screens can also be accessed.

Pressing the POWER button will access a screen showing power data for the unit. The ability to view the unit’s electrical performance and to set starter setpoints on the interface screen is an optional extra available at the time of purchase. If the option is supplied on the unit, a “POWER” button will be visible on the upper left side of the VIEW screen. Pressing the button will open the screen shown in Figure 6.

Figure 6, Expanded Power View Screen

The screen shown to the right will be superimposed on the right side of the VIEW screen shown in Figure 5 when the optional “Full Meter Display” is included with the unit. This screen will remain visible until another display button; such as STATE, I/O, etc is pressed.

If this option is not included, Percent Unit RLA on the HOME VIEW screen displays the current percent of the *unit* rated loads amps.

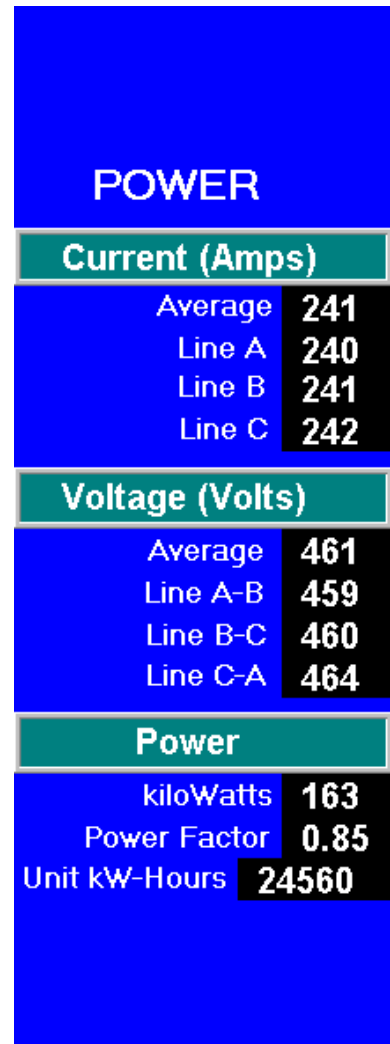

Figure 7, View Menu

This View Menu is accessed by pressing the MENU button from the Detail View Screen. The menu screen is used to access other screens containing various data. A screen with unit temperatures and pressures is shown on a BAR CHART SCREEN (see Figure 11 on page 21). This screen is accessed by pressing LABELED BAR GRAPHS. Pressing BAR GRAPHS will access the same screen, but without the labels

There is more data available to view and it is accessed through the buttons on the right of the screen. It is segregated by general topics that are self-explanatory. These buttons are also repeated on the Detail View Screen as previously noted. If the starter display option has been included, a POWER button will be located above the STATE button.

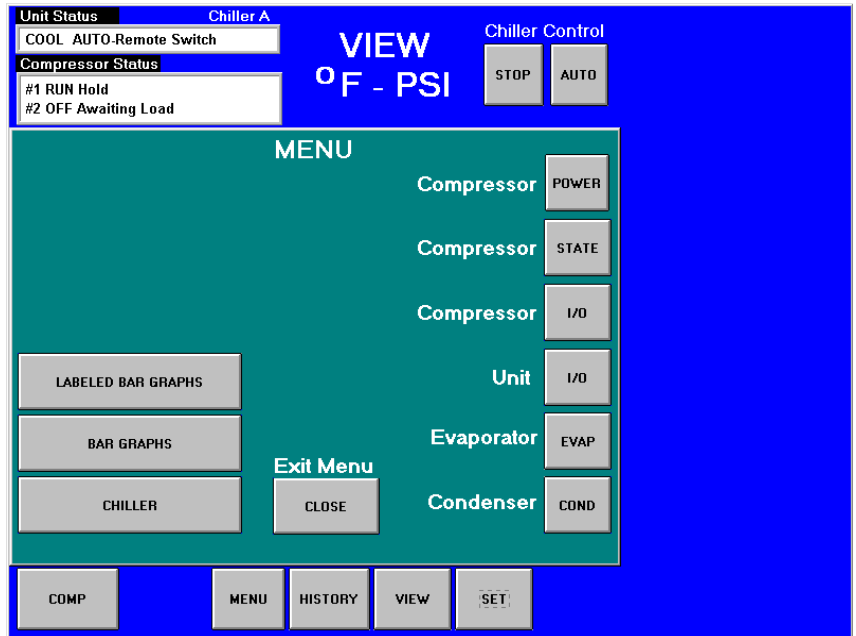
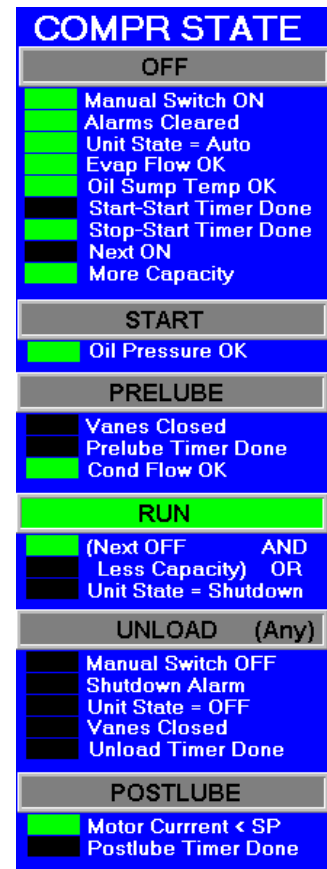

Figure 8, View Compressor State Screen

For example, pressing the Compressor-State button will yield the following screen superimposed on the right side of the Detail View Screen. The Compressor State screen is basically a compilation of the events that the chiller sequences through at startup. A green light (light gray in the figure) indicates that a particular sequence requirement has been satisfied. It is recommended that this screen be viewed during the start up sequence. One can see the requirements light up as they are met and quickly see why a non-start may have occurred. For example, The Evap Flow OK will light when the evaporator flow switch is closed by flow, Oil Sump Temp OK will light if (or when) the oil temperature is above the Startup Temperature Setpoint, both timers must be timed out, Oil Pressure OK will light when sufficient oil pressure is achieved, etc.

The bottom three sections (from "RUN" down) are in effect during the shut down process. The compressor is officially off when the Postlube Timer is Done. The sequence transitions back to OFF at this point and the OFF light will be illuminated.



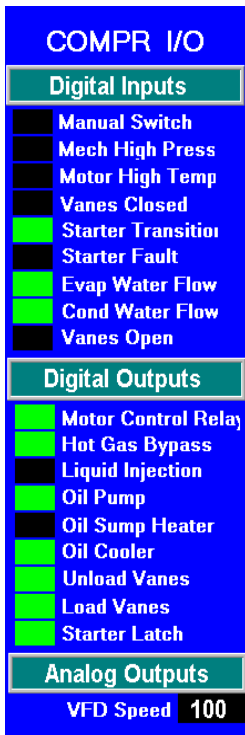

Figure 9, View Compressor Input/Output Status

Pressing the Compressor I/O button on the VIEW MENU screen will access the screen shown to the right. It is superimposed on the right side of the Detail View Screen. It gives the status of the *compressor* digital inputs and analog and digital outputs. Many of these I/Os also appear in the Compressor State screen since they are part of the start up sequence and define the compressor state at any given time. Dual compressor units will have two of any compressor screen.

A COMP button will appear in the lower left-hand corner of the Detail View Screen (Figure 5 on page 17) on dual compressor WDC units. This button will toggle compressor data from #1 compressor to #2 compressor.

Figure 10, Unit Input/Output Screen

The screen shown to the left gives the status of the *unit* controller digital inputs and outputs and analog outputs. The unit controller is concerned with the operation of the entire unit and its I/Os reflect this. Note that proof of water flow, operation of condenser and evaporator water pumps and tower operation constitute most of the data flow. An illuminated block (gray in the figure) indicated that either an input or output signal exists

Pressing the Evaporator or Condenser buttons on Detail View Screen will display pertinent vessel temperatures and pressures. The screens are very simple, self-explanatory, and not shown here.

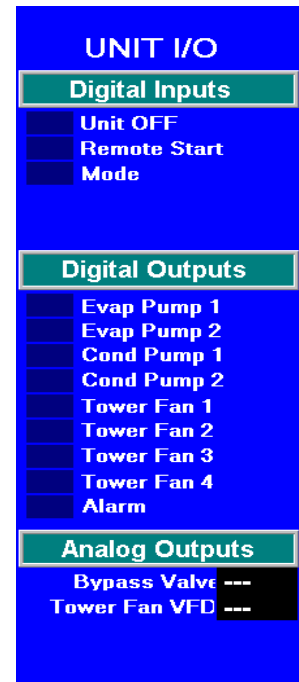
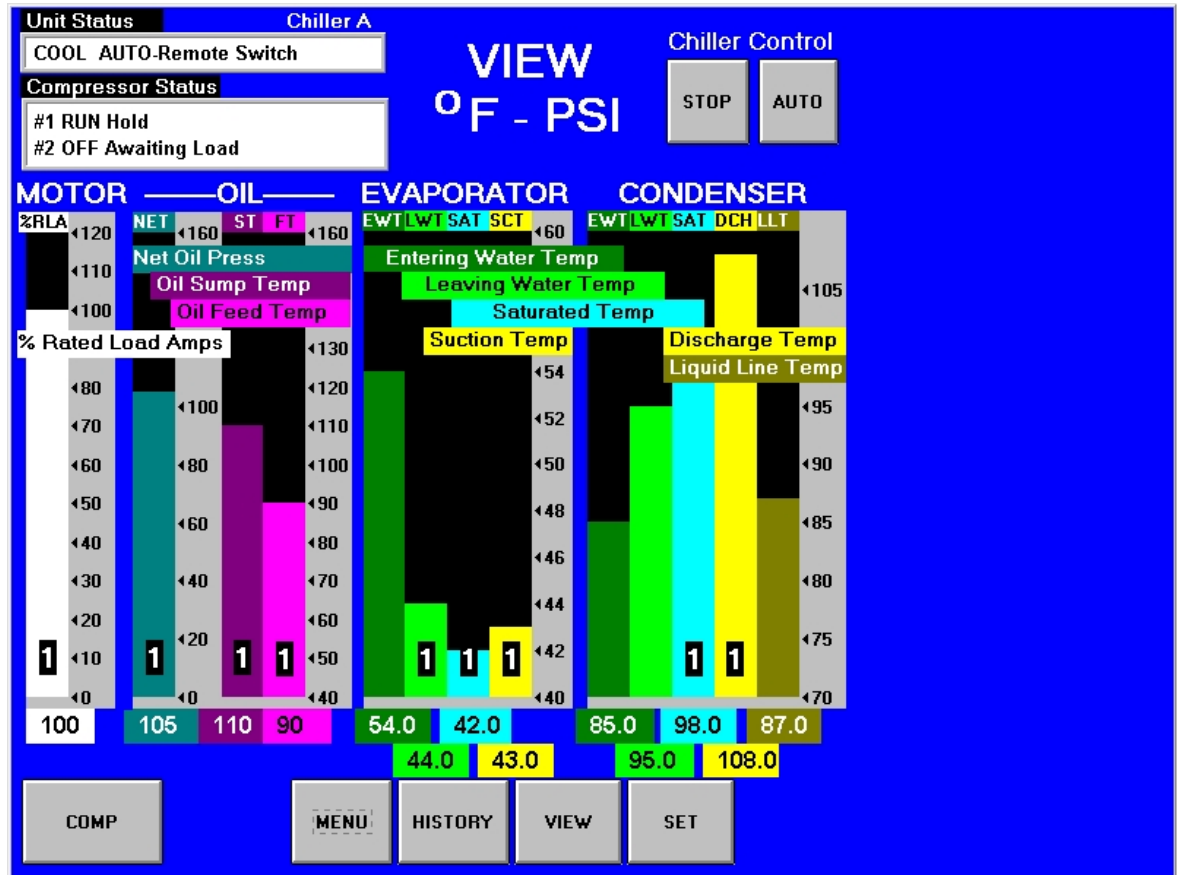

Figure 11, Bar Chart with Labels



The bar chart screen is accessed from the MENU screen (Figure 7) by selecting LABELED BAR GRAPHS. Selecting BAR CHARTS will access the same graph, but without the labels.

SET Screens

The set screens on the Interface Panel are used to input the many setpoints associated with equipment of this type. MicroTech II provides an extremely simple method for accomplishing this. (NOTE: If the Interface Panel is unavailable, the unit controller can be used to change setpoints.) Appropriate setpoints are factory set and checked by McQuayService or Factory Authorized Service Company during commissioning. However, adjustments and changes are often required to meet job conditions. Certain settings involving pumps and tower operation are field set.

Pressing the SET button found on almost every screen accesses the last SET screen used or the SERVICE screen, whichever of the two was used last.

When in any SET screen, pressing the SET button again will toggle to the SERVICE screen shown on page 35.

Figure 12, A Typical SETPOINT Screen

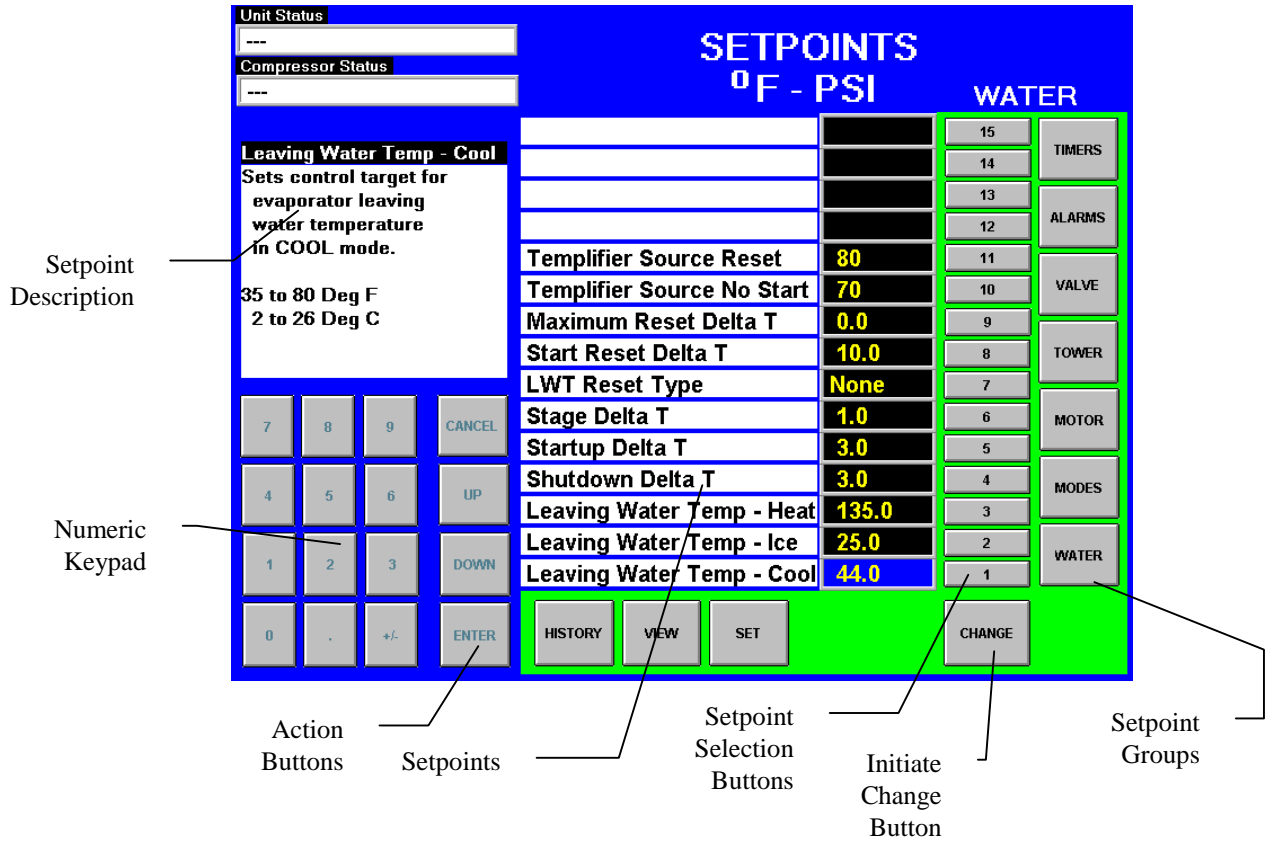

The above figure shows the SETPOINT screen with WATER setpoints selected. The various setpoint groups are in a column on the right side of the screen. Each button contains a number of setpoints grouped together by similar content. The WATER button (as shown) contains various setpoints relating to water temperatures. If either starter display option has been included, an additional button, STARTER, will be located above the TIMERS button.

NOTE: Some setpoints that do not apply to a particular application may still be listed on the screen. They will be inactive and can be ignored. For example, of setpoints 1, 2, and 3 above, only one will be active depending on the unit mode selected in the MODE setpoints, 10 and 11 only for Templifiers. The numbered buttons in the second from right column are pressed to select a particular setpoint. The selected setpoint will appear in blue on the screen and a description of it (with the range of available settings) will appear in the upper left-hand box.

Procedure for Changing a Setpoint

A list of setpoints, their default value, their available setting range, and password authority are in **Error! Reference source not found.** on page **Error! Bookmark not defined.** for the unit and Table 24 on page 63 for the compressor.

1. Press the applicable Setpoint Group Button. A complete explanation of setpoint content of each group follows this section.
2. Select the desired setpoint by pressing the numbered button.
3. Press the CHANGE button indicating that you wish to change a setpoint value. The KEYBOARD screen will be turned on automatically for entering the password.
 - O = Operator level password is 100
 - M = Manager level password is 2001

- T = Technician level password is reserved for authorized technicians
4. Press the appropriate numbers in the numeric keyboard to enter the password. There is a small delay between pressing the keypad and recording the entry. Be sure that an asterisk appears in the window before pressing the next number. Press ENTER to return to the SETPOINT screen. The password will remain open for 15 minute after initiation and does not need to be re-entered during this period.
 5. Press CHANGE again. The right side of the screen will turn blue (inactive).
 6. The numeric keypad and action buttons in the lower left-hand corner of the screen will be activated (the background will turn green). Setpoints with numeric values can be changed in two ways:
 - Select the desired value by pressing the numbered buttons. Press ENTER to enter the value or CANCEL to cancel the transaction.
 - Press the UP or DOWN button to increase or decrease the value displayed. Press ENTER to enter the value or CANCEL to cancel the transaction.

Some setpoints are text rather than numeric values. For example, LWT Reset Type can be "None" or "4-20 ma". The selection can be made by toggling between choices using the UP or Down button. If dashed lines appear in the setpoint window, it indicates that you have toggled too far and need to reverse direction. Press ENTER to enter the choice or CANCEL to cancel the transaction.

Once CHANGE is selected, the CANCEL or ENTER buttons must be pressed before another setpoint can be selected.
 7. Additional setpoints can be changed by selecting another setpoint on the screen or by selecting an entirely new group of setpoints.

Explanation of Setpoints

Each of the seven setpoint group of screens are detailed in the following section. In many cases the setpoint content is obvious and no explanation is included.

1. TIMERS, for setting timers such as start-to-start, prelube, postlube, etc.
2. ALARMS, for setting the limit and shutdown alarms.
3. VALVE, sets the parameters for operation of an optional field installed tower bypass valve.
4. TOWER, selects the method of controlling the cooling tower and sets the parameters for fan staging/VFD.
5. MOTOR, selects motor related setpoints such as amp limits, VFD settings, etc. Also has maximum and minimum rate of change of chilled water temperature.
6. MODES, selects various modes of operation such as control source, multiple compressor staging, pump staging, BAS protocol, etc.
7. WATER, leaving water temperature setpoint, start and stop delta-T, resets, etc.

STARTER Setpoints

Figure 13, Optional Starter Setpoint Screen

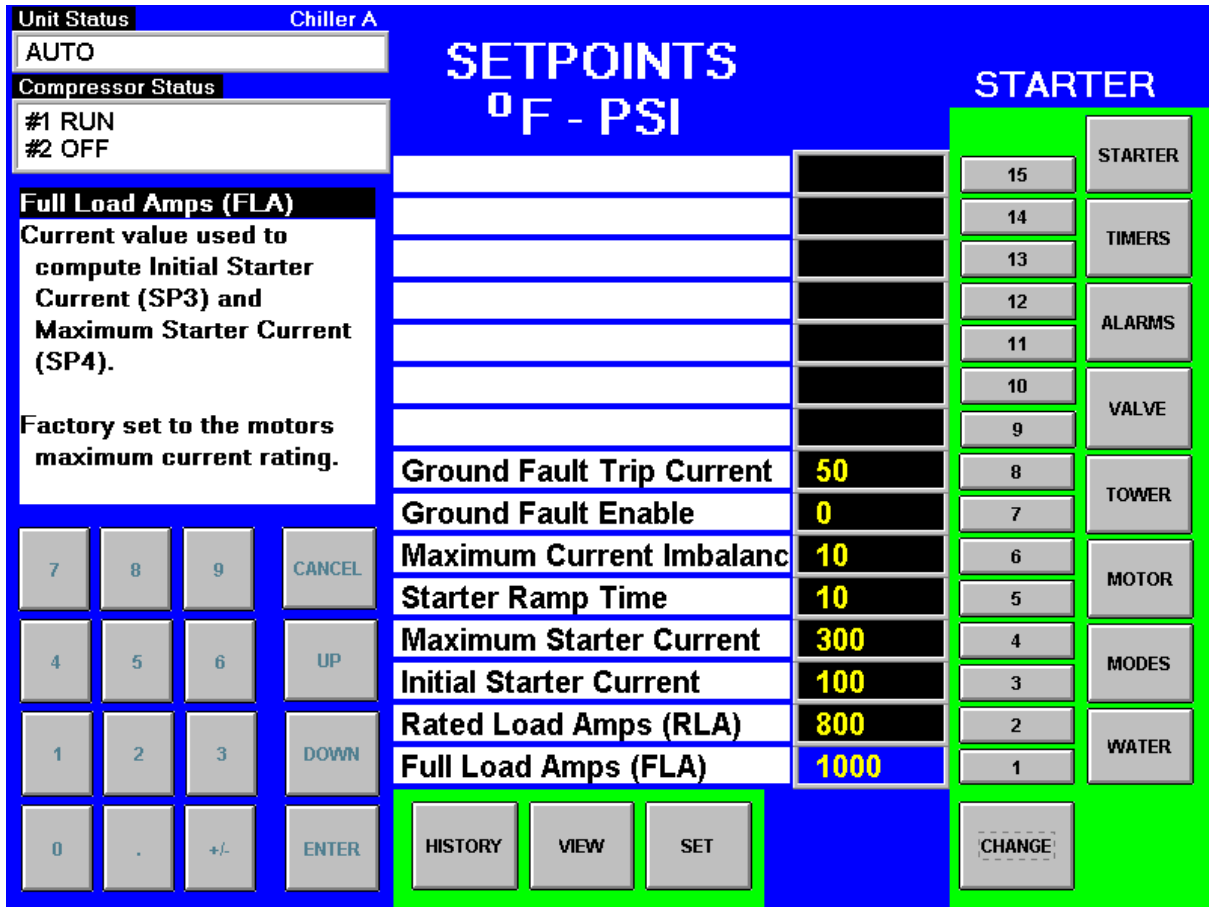

Table 12, Starter Setpoints

Description	No.	Default	Range	Pass-word	Comments
Ground Fault Current Trip	8	1 %	1 to 100% RLA	M	Sets the value for ground current above which the compressor will be shut down
Ground Fault Enable	7	OFF	On or OFF	M	Turns the ground fault option on or off
Maximum Current Unbalance	6	10%	5% to 40%	T	Sets the value for current unbalance above which the compressor will be shut down
Starter Ramp Time	5	15 sec.	0 to 30 seconds	T	Sets the time the starter ramps up the motor current
Maximum Starter Current	4	600%	100% to 800% of FLA (SP1)	T	Sets the maximum current when the compressor starts
Initial Starter Current	3	100%	50% to 400% of FLA (SP1)	T	Sets the initial current when the compressor starts
Rated load Amps	2	1 A	Factory set at design conditions	T	Value that gives the 100% RLA value and used for motor protection
Full Load Amps	1	1 A	Factory set to motor max current rating	T	Value used to compute SP3 and SP4

The setpoints shown above are for solid state starters. Other types of starters will have slightly different setpoints. Units without the starter display option will have their setpoints set in the starter itself.

TIMERS Setpoint

Figure 14, TIMERS Setpoint Screen

Table 13, TIMER Setpoints

Description	No.	Default	Range	Pass-word	Comments
Postlube Timer	8	30 sec	10 to 240 sec	T	Time for postlube before compressor can stop
Unload Timer	7	30 sec	10 to 240 sec	T	Time compressor will unload before going to postlube
Full Load Timer	6	300 sec	0 to 999 sec	T	Time compressor must load for full open vanes
Interlock	5				WMC only
Prelube Timer	4	30 sec	10 to 240 sec	T	Time compressor must prelube before starting
Stop-Start	3	3 min	3 to 20 min	M	Time from when compressor stops to when it can restart
Start-Start	2	40 min	15 to 60 min	M	Time from when compressor starts to when it can start again
Evap Recirculate	1	30 sec	15 sec to 5 min	M	Time that evaporator pump must run before compressor start

ALARMS Setpoint

Figure 15, ALARMS Setpoint Screen

Unit Status Chiller A
COOL AUTO-Remote Switch

Compressor Status
#1 RUN Hold
#2 OFF Awaiting Load

Surge Temperature Limit
At start, Surge Temp(ST) is compared to this SP. (ST=Sctn Temp-Evap LWT) if Less: Alarm occurs when ST>2X this SP. if Greater: Slope alarm is active until ST<this SP. Then alarm at 2X this SP. 2 to 25 °H, 1.1 to 13.9 jae

SETPOINTS °F - PSI

Parameter	Value	Alarm No.	Category
Low Oil Net Pressure	34.0	15	STARTER
Low Oil Delta Temperature	34.0	14	TIMERS
High Oil Feed Temperature	10	13	ALARMS
Condenser Freeze Protect	25	12	ALARMS
Evaporator Freeze Protect	50	11	VALVE
Motor Current Threshold	40	10	VALVE
Surge Slope Limit	30	9	TOWER
Surge Temperature Limit	140	8	TOWER
High Discharge Temp-Stop	190	7	MOTOR
High Discharge Temp-Load	170	6	MOTOR
High Condenser Pressure	140	5	MODES
Low Evap Pressure-Stop	29	4	MODES
Low Evap Pressure-Unload	31	3	WATER
Low Evap Pressure-Inhibit	33	2	WATER

ALARMS

Buttons: 7, 8, 9, CANCEL, 4, 5, 6, UP, 1, 2, 3, DOWN, 0, ., +/-, ENTER, HISTORY, VIEW, SET, CHANGE

Table 14, ALARM Setpoints

Description	No.	Default	Range	Pass-word	Comments
Low Net Oil Pressure	14	50 psi	50 to 90 psi	T	Min net pressure (feed minus sump)
Low Oil Delta Temperature	13	40 °F	20 to 80 °F	T	Min Delta-T (sat evap minus oil temp)
High Oil Feed Temperature	12	140 °F	120 to 240 °F	T	Max oil temperature
Condenser Freeze	11	34.0 °F	-9.0 to 45.0 °F	T	Minimum cond. sat. temp. to start pump
Evaporator Freeze	10	34.0 °F	-9.0 to 45.0 °F	T	Minimum evap. sat. temp. to start pump
Motor Current Threshold	9	10%	3% to 99%	T	Min %RLA to consider motor off
Surge Slope Limit	8	20	1 – 99 deg F/min.	T	Surge slope temp that triggers alarm
Surge Temperature Limit	7	6	2 – 25 deg F	T	See screen above
High Discharge Temp-Shutdown	6	190 °F	120 to 240 °F	T	Max discharge gas temp, stop compressor
High Discharge Temp-Load	5	170 °F	120 to 240 °F	T	Max discharge gas temp – load comp
High Condenser Pressure	4	140 psi	120 to 240 psi	T	Max discharge pressure, stop compressor
Low Evap Pressure, Stop	3	29 psi	10 to 45 psi	T	Min evap pressure – stop compressor
Low Evap Pressure-Unload	2	31 psi	20 to 45 psi	T	Min evap pressure – unload compressor
Low Evap Pressure-Inhibit	1	33 psi	20 to 45 psi	T	Min evap pressure – inhibit loading

Cooling Tower Bypass VALVE Settings

Figure 16, Tower Bypass VALVE Setpoint Screen

The screenshot displays the 'SETPOINTS OF - PSI VALVE' screen. On the left, there are status indicators for 'Unit Status' (AUTO), 'Compressor Status' (#1 RUN, #2 OFF), and 'Tower Valve Type' (NC: Valve is normally closed to tower, NO: Valve is normally open to tower). Below these are numeric keypad buttons (0-9, ., +/-, ENTER, CANCEL, UP, DOWN) and function buttons (HISTORY, VIEW, SET, CHANGE). The main area is a table of setpoints:

Parameter	Current Value	Setpoint No.	Category
Valve Control Slope Gain	25	15	TIMERS
Valve Control Error Gain	25	14	TIMERS
Valve Control Range (Max)	90	13	ALARMS
Valve Control Range (Min)	10	12	ALARMS
Temp - Max Start Position	90	11	VALVE
Maximum Start Position	100	10	VALVE
Temp - Min Start Position	60	9	TOWER
Minimum Start Position	0	8	TOWER
Stage Down @	20	7	MOTOR
Stage Up @	80	6	MOTOR
Valve Deadband (Lift)	4.0	5	MODES
Valve Deadband (Temp)	2.0	4	MODES
Valve Target (Lift)	30	3	WATER
Valve Target (Temp)	65	2	WATER
Tower Valve Type	NC to Tw	1	WATER

Table 15, Tower Bypass VALVE Setpoints (See page 29 for complete explanation.)

Description	No.	Default	Range	Pass-word	Comments
Slope Gain	15	25	10 to 99	M	Control gain for temperature (or lift) slope
Error Gain	14	25	10 to 99	M	Control gain for temperature (or lift) error
Valve Control Range(Max)	13	100%	0 to 100%	M	Maximum valve position, overrides all other settings
Valve Control Range (Min)	12	10%	0 to 100%	M	Minimum valve position, overrides all other settings
Temp - Maximum Position	11	90 °F	0 to 100 °F	M	Condenser EWT at which valve should be open to tower
Maximum Start Position	10	100%	0 to 100%	M	Initial valve position when condenser EWT is at or above Setpoint # 9
Temp - Minimum Position	9	60 °F	0 to 100 °F	M	Condenser EWT at which initial valve position is set to Setpoint # 6
Minimum Start Position	8	10%	0 to 100%	M	Initial position of valve when condenser EWT is at or below Setpoint # 7
Stage Down @	7	20%	0 to 100%	M	Valve position below which the fans can stage down (Tower Setpoint #2 = Valve Stage Down VFD speed below which the next fan speed can turn off (Tower Setpoint # 2 = valve/VFD ????)
Stage Up @	6	80%	0 to 100%	M	Valve position above which the fans can stage up (Tower Setpoint #2 = Valve Stage Down VFD speed above which the next fan speed can turn on (Tower Setpoint # 2 = valve/VFD ????)
Valve Deadband (Lift)	5	4.0 psi	1.0 to 20.0 psi	M	Control deadband, Tower Setpoint #1=Lift
Valve Deadband (Temp)	4	2.0 °F	1.0 to 10.0 °F	M	Control deadband, Tower Setpoint #1=Temp
Valve Target (Lift)	3	30 psi	10 to 130 psi	M	Target for lift pressure (Tower Setpoint #1= Lift), Works with Setpoint # 5
Valve Setpoint (Temp)	2	65 °F	40 to 120 °F	M	Target for condenser EWT (Tower Setpoint #1= Temp), Works with Setpoint # 4
Valve Type	1	NC (To Tower)	NC, NO	M	Normally closed or normal open to tower

Cooling TOWER Fan Settings

Figure 17, Cooling TOWER Fan Setpoint Screen (See page 29 for complete explanation.)

Unit Status	Compressor Status	Cooling Tower Control	SETPOINTS °F - PSI	TOWER
AUTO	#1 RUN #2 OFF	NONE: No tower control. TEMP: Fan & bypass valve control is based on entering condenser temperature LIFT: Control is based on lift pressure.	Stage #4 ON (Lift)	65
			Stage #3 ON (Lift)	55
			Stage #2 ON (Lift)	45
			Stage #1 ON (Lift)	35
			Stage #4 ON (Temp)	85
			Stage #3 ON (Temp)	80
			Stage #2 ON (Temp)	75
			Stage #1 ON (Temp)	70
			Stage Differential (Lift)	6.0
			Stage Differential (Temp)	3.0
			Fan Stage Down Time	5
			Fan Stage Up Time	2
			Cooling Tower Stages	4
			Twr Bypass Valve/Fan VFD	Valve SP
			Cooling Tower Control	Temp

Table 16, Tower Fan Settings

Description	No.	Default	Range	Pass-word	Comments
Stage #4 On (Lift)	15	65 psi	10 to 130 psi	M	Lift pressure for fan stage #4 on
Stage #3 On (Lift)	14	55 psi	10 to 130 psi	M	Lift pressure for fan stage #3 on
Stage #2 On (Lift)	13	45 psi	10 to 130 psi	M	Lift pressure for fan stage #2 on
Stage #1 On (Lift)	12	35 psi	10 to 130 psi	M	Lift pressure for fan stage #1 on
Stage #4 On (Temp)	11	85 °F	40 to 120 °F	M	Temperature for fan stage #4 on
Stage #3 On (Temp)	10	80 °F	40 to 120 °F	M	Temperature for fan stage #3 on
Stage #2 On (Temp)	9	75 °F	40 to 120 °F	M	Temperature for fan stage #2 on
Stage #1 On (Temp)	8	70 °F	40 to 120 °F	M	Temperature for fan stage #1 on
Stage Differential (Lift)	7	6.0 psi	1.0 to 20.0 psi	M	Fan staging deadband with Setpoint # 1=Lift
Stage Differential (Temp)	6	3.0 °F	1.0 to 10.0 °F	M	Fan staging deadband with Setpoint #1=Temp
Stage Down Time	5	5 min	1 to 60 min	M	Time delay between stage up/down event and next stage down
Stage Up Time	4	2 min	1 to 60 min	M	Time delay between stage up/down event and next stage up
Tower Stages	3	2	1 to 4	M	Number of fan stages used
Valve/VFD Control	2	None	None, Valve Setpoint, Valve Stage, VFD Stage, Valve SP/VFD Stage	M	None: No tower valve or VFD Valve Setpoint: Valve controls to VALVE SP3(4) & 5(6) Valve Stage: Valve control setpoint changes to fan stage setpoint VFD Stage: 1 st fan is VFD controlled, no valve Valve Setpoint/VFD Stage: Both valve and VFD
Tower Control	1	None	None, Temperature, Lift	M	None: No tower fan control Temperature: Fan and valve controlled by EWT Lift: Fan and valve controlled by lift pressure

Explanation of Tower Control Settings

MicroTech II control can control cooling tower fan stages, a tower bypass valve, and/or a tower fan VFD if the chiller has a dedicated cooling tower.

The Tower Bypass Valve position will always control the Tower Fan Staging if Valve Setpoint, Stage Setpoint is selected. Fan staging is determined by Min & Max Tower Valve Position.

There are five possible tower control strategies as noted below and explained in detail later in this section. They are selected from SETPOINT TOWER SP2.

1. NONE, Tower fan staging only. In this mode the tower fan staging (up to 4 stages) is controlled by either the condenser Entering Water Temperature (EWT) or LIFT pressure (difference between the condenser and evaporator pressures). Tower bypass or fan speed are not controlled.
2. VALVE SP, Tower staging with low-limit controlled bypass valve. In this mode the tower fans are controlled as in #1 plus a tower bypass valve is controlled to provide a minimum condenser EWT. There is no interconnection between the fan control and the valve control.
3. VALVE STAGE, Tower staging with stage controlled bypass valve. In this mode the bypass valve controls between fan stages to smooth the control and reduce fan cycling
4. VFD STAGE. In this mode a VFD controls the first fan. Up to 3 more fans are staged on and off and there is no bypass valve.
5. VALVE/VFD, Tower fan control with VFD plus bypass valve control.

Tower Fan Staging Only (NONE)

The following settings are used for the Tower Fan Staging Only mode, (SP= setpoint)

- 1) TOWER SETPOINT Screen
 - i) SP1. Select TEMP if control is based on condenser EWT or LIFT if based on compressor lift expressed in psi.
 - ii) SP2. Select NONE for no bypass valve or fan VFD control.
 - iii) SP3. Select one to four fan outputs depending on the number of fan stages to be used. More than one fan can be used per stage through the use of relays.
 - iv) SP4. Select STAGE UP TIME from 1 to 60 minutes. The default value of 2 minutes is probably a good starting point. The value may need to be adjusted later depending on actual system operation.
 - v) SP5. Select STAGE DOWN TIME from 1 to 60 minutes. The default value of 5 minutes is probably a good starting point. The value may need to be adjusted later depending on actual system operation.
- 2) If TEMP is selected in SP1, use
 - i) SP6. Select STAGE DIFFERENTIAL in degrees F, start with default of 3 degrees F.
 - ii) SP8-11. Set the STAGE ON temperatures consistent with the temperature range over which the condenser EWT is desired to operate. The default values of 70°F, 75°F, 80°F and 85°F are a good place to start in climates with moderate wet bulb temperatures. The number of STAGE ON setpoints used must be the same as SP3.
- 3) If LIFT is selected in SP1, use
 - i) SP7. Select STAGE DIFFERENTIAL in PSI. Start with default of 6 PSI.
 - ii) SP12-15. Start with default setpoints. The number of STAGE ON setpoints used must be the same as SP3.

See Figure 2, Field Wiring Diagram on page 11 for fan staging field wiring connection points.

Tower Fan Staging With Bypass Valve Controlling Minimum EWT (VALVE SP)

1) TOWER SETPOINT Screen

- a) SP1. Select TEMP if control is based on condenser EWT or LIFT if based on compressor lift expressed in psi.
- b) SP2. Select Valve SP for control of bypass valve based on temperature or lift.
- c) SP3. Select one to four fan outputs depending on the number of fan stages to be used. More than one fan can be used per stage through the use of relays.
- d) SP4. Select STAGE UP TIME from 1 to 60 minutes. The default value of 2 minutes is probably a good starting point. The value may need to be adjusted later depending on actual system operation.
- e) SP5. Select STAGE DOWN TIME from 1 to 60 minutes. The default value of 5 minutes is probably a good starting point. The value may need to be adjusted later depending on actual system operation.
- f) If TEMP is selected in SP1, use
 - i) SP6. Select STAGE DIFFERENTIAL in degrees F, start with default of 3 degrees F.
 - ii) SP8-11. Set the STAGE ON temperatures consistent with the temperature range over which the condenser EWT is desired to operate. The default values of 70°F, 75°F, 80°F and 85°F are a good place to start in climates with moderate wet bulb temperatures. The number of STAGE ON setpoints used must be the same as SP3.
- g) If LIFT is selected in SP1, use
 - i) SP7. Select STAGE DIFFERENTIAL in PSI. Start with default of 6 PSI.
 - ii) SP12-15. Start with default setpoints. The number of STAGE ON setpoints used must be the same as SP3.

2) VALVE SETPOINT Screen

- a) SP1, Select NC or NO depending if valve is closed to tower with no control power or open to tower with no control power.
- b) If TEMP was selected for fan control above, use
 - i) SP2, Set the VALVE TARGET (setpoint), usually 5 degrees below the minimum fan stage setpoint established in TOWER SP11. This keeps full flow through the tower until the last fan is staged off.
 - ii) SP4, Set VALVE DEADBAND, the default of 2 degrees F is a good place to start.
 - iii) SP8, Set MINIMUM VALVE POSITION when EWT is at or below SP9. Default is 0%.
 - iv) SP9, Set the EWT at which the valve position will be at (SP8). Default is 60°F.
 - v) SP8, Set MINIMUM VALVE POSITION when EWT is at or below SP9. Default is 0%.
 - vi) SP9, Set the EWT at which the valve position is set to allow the fans to stage up (SP8). Default is 60°F.
 - vii) SP10, Set the initial valve position when EWT is at or above SP11. Default is 100%.
SP11, Set the EWT at which initial valve position is set to SP8. Default is 90°F.
 - viii) SP12, Set the minimum position to which the valve can go. Default is 10%.
 - ix) SP13, Set the maximum position to which the valve can go. Default is 100%.
 - x) SP14, Set the control gain for error. Default is 25.
 - xi) SP15, Set the control gain for slope. Default is 25.

NOTE: Setpoints 14 and 15 are site specific dealing with system fluid mass, component size and other factors affecting the reaction of the system to control inputs. These setpoints should be set by personnel experienced with setting up this type of control.

- c) If LIFT was selected for fan control, use
- i) SP3, Set the VALVE TARGET (setpoint), usually 30 psi below the minimum fan stage setpoint established in TOWER SP12. This keeps full flow through the tower until the last fan is staged off.
 - ii) SP5, Set VALVE DEADBAND, the default of 6 psi is a good place to start.
 - iii) SP8, Set MINIMUM VALVE POSITION when EWT is at or below SP9. Default is 0%.
 - iv) SP9, Set the EWT at which the valve position will be at (SP8). Default is 60°F.
 - v) SP12, Set the minimum position to which the valve can go. Default is 10%.
 - vi) SP13, Set the maximum position to which the valve can go. Default is 100%.
 - vii) SP14, Set the control gain for error. Default is 25.
 - viii) SP15, Set the control gain for slope. Default is 25.

NOTE: Setpoints 14 and 15 are site specific dealing with system fluid mass, component size and other factors affecting the reaction of the system to control inputs. These setpoints should be set by personnel experienced with setting up this type of control.

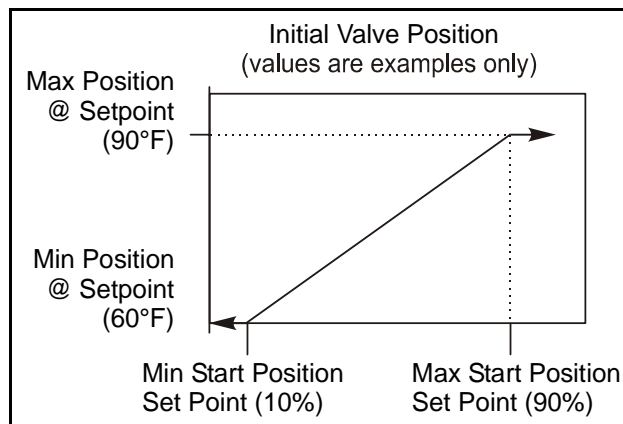

See Figure 2 on page 11 for fan staging and bypass valve field wiring connection points.

Tower Staging with Bypass Valve Controlled by Fan Stage (VALVE STAGE)

This mode is similar to #2 above except that the bypass valve setpoint changes to be set at the same point of whatever fan stage is active rather than just maintaining a single minimum condenser EWT. In this mode the valve controls between fan stages and tries to maintain the fan stage setting in effect. When it is max open or max closed (staging up or down) and the temperature (or lift) moves to the next fan stage, the valve will go the opposite max setting. This mode reduces fan cycling.

This mode is programmed the same as Mode #2 above except that in SETPOINT, TOWER, SP2, VALVE STAGE is selected instead of VALVE SP.

Fan VFD, No Bypass Valve (VFD STAGE)

The fan VFD mode assumes the tower is driven by one large fan. Set up is as above except in SETPOINT, TOWER, SP2, VALVE/VFD is selected.

MOTOR Setpoint Screen

Figure 18, MOTOR Setpoint Screen

The screenshot displays the 'SETPOINTS OF - PSI' screen for 'Chiller A'. It features a central list of 15 setpoints with their current values and a numeric keypad on the left. On the right, there are function buttons for 'STARTER', 'TIMERS', 'ALARMS', 'VALVE', 'TOWER', 'MOTOR', 'MODES', and 'WATER'. A 'CHANGE' button is at the bottom right.

Setpoint Description	Current Value	Function Button
Lift @ 100% VFD Speed	15	STARTER
VFD Speed @ Zero Lift	1000	TIMERS
VFD Minimum Speed	40	ALARMS
Compressor VFD	40	VALVE
Oil No Start Differential	50	TOWER
Nominal Capacity	70	MOTOR
Maximum LWT Rate	NO	MODES
Minimum LWT Rate	0.5	WATER
Soft Load Ramp Time	0.1	
Initial Soft Load Limit	5	
Soft Load Enable	40	
Nameplate RLA	OFF	
Maximum Amps	100	
Minimum Amps	40	
Demand Limit Enable	OFF	

Unit Status: COOL AUTO-Remote Switch
Compressor Status: #1 RUN Hold, #2 OFF Awaiting Load
Demand Limit Enable: ON: Limits %RLA to a value set by the Demand Limit analog input. where: 4mA = 0 %RLA, 20mA = 100 %RLA. OFF: The Demand Limit input is ignored.

Keypad: 0-9, ., +/-, ENTER, CANCEL, UP, DOWN.

Buttons: HISTORY, VIEW, SET, CHANGE.

Table 17, MOTOR Setpoint Settings

Description	No.	Default	Range	Pass-word	Comments
Lift @ 100% Speed	15	40 °F	30 to 60 °F	T	Temp lift at 100 % speed (cond sat – evap sat temp)
Speed @ 0 Lift	14	50%	0 to 100%	T	Lift @ min speed as a % of 100 % lift
Minimum Speed	13	70%	60 to 100%	T	Min VFD speed, has priority over SPs 11 & 12
VFD	12	No	No, Yes	T	VFD on unit or not
Oil No Start Diff (above Evap Temp)	11	40 °F	30 to 60 °F	T	Minimum Delta-T between oil sump temperature and saturated evaporator temperature
Nominal Capacity	10		0 to 9999 Tons		Determines when to shut off a compressor
Maximum Rate	9	0.5 °F/min	0.1 to 5.0 °F/min	M	Inhibits loading if LWT change exceed the setpoint value.
Minimum Rate	8	0.1 °F/min	0.0 to 5.0 °F/min	M	Additional compressor can start if LWT change is below setpoint.
Soft Load Ramp	7	5 min	1 to 60 min	M	Time period to go from initial load point (% RLA) set in SP 5 to 100% RLA
Initial Soft Load Amp Limit	6	40%	20 to 100%	M	Initial amps as % of RLA
Soft Load Enable	5	OFF	OFF, ON	M	Soft load on or off
Nameplate RLA	4				Not used on WSC/WDC models
Maximum Amps	3	100%	40 to 100%	T	% RLA above which loading is inhibited (Load Limit)
Minimum Amps	2	40%	20 to 80%	T	% RLA below which unloading is inhibited
Demand Limit Enable	1	OFF	OFF, ON	O	ON sets %RLA at 0% for 4 mA external signal and at 100% RLA for 20 mA signal

MODES Setpoints

Figure 19, MODES Setpoint Screen

Parameter	Value	Mode No.	Mode Name
Compr #2 Stage Sequence #	1	15	STARTER
Compr #2 Staging Mode	Normal	14	TIMERS
Compr #1 Stage Sequence #	1	13	ALARMS
Compr #1 Staging Mode	Normal	12	VALVE
Maximum Compressors ON	2	11	TOWER
BAS Network Protocol	MODBUS	10	MOTOR
Hot Gas Control Point	OFF	9	MODES
Hot Gas Mode	Normal	8	WATER
Condenser Pump	#2 Only	7	
Evaporator Pump	#1 Only	6	
Available Modes	Cool	5	
Control Source	Switches	4	
Unit Mode	Cool	3	
Unit Enable	ON	2	

Table 18, MODE Setpoint Settings

Description	No.	Default	Range	Pass-word	Comments
Comp # 2 Stage Sequence	14	1	1,2, ... (# of Compressors)	M	Sets sequence number for # 2 compressor, if 1 it is always first to start, if 2 is always second (Note 1)
Comp # 2 Mode	13	Normal	Normal, Efficiency, Pump, Standby	M	Normal uses standard sequencing Efficiency starts one compressor on each dual unit Pump starts all compressors on one chiller first Standby uses this compressor only if another fails.
Comp #1 Stage Sequence	12	1	1,2, ... (# of Compressors)	M	Sets sequence number for # 1 compressor, if 1 it is always first to start, if 2 is always second (Note 1)
Comp #1 Mode	11	Normal	Normal, Efficiency, Pump, Standby	M	Ditto No. 12.
Max. Comp. ON	10	1	1-16	M	Total number of compressors minus standby
BAS Protocol	9	Modbus	None, Local, Remote, BACnet, LonWorks, MODBUS,	M	Sets BAS Standard Protocol to be used or LOCAL if none.
Hot Gas Control Point	8	30%	20 to 70%	T	LWT or % RLA below which HGBP solenoid is on
Hot Gas Bypass Mode	7	Normal	Off, Water LWT, %RLA	T	Sets mode for hot gas operaton
Cond Pump	6	Pump #1 Only	Pump #1 Only, Pump #2 Only, Auto Lead, #1 Primary, #2 Primary	M	Pump #1 Only, Pump #2 Only, use only these pumps AUTO, balance hours between #1 and #2 #1 Primary, #2 Primary, if primary fails, use other
Evap Pump	5	Pump #1 Only	Pump #1 Only, Pump #2 Only, Auto Lead, #1 Primary, #2 Primary	M	Pump #1 Only, Pump #2 Only, use only these pumps AUTO, balance hours between #1 and #2 #1 Primary, #2 Primary, if primary fails, use other
Available Modes	4	COOL	COOL, COOL/ICE, ICE, COOL/HEAT, HEAT	T	Sets modes that can be selected in SP 2
Control Source	3	LOCAL	LOCAL, BAS, SWITCH	O	Sets control source
Unit Mode	2	COOL	COOL, ICE, HEAT, TEST		Selects from MODES in SP4
Unit Enable	1	OFF	OFF, ON	O	OFF, everything is off. ON, Evap pump on, comp, cond pump and tower on as required to meet LWT

WATER Setpoints

Figure 20, WATER Setpoint Screen

Unit Status Chiller A
COOL AUTO-Remote Switch

Compressor Status
#1 RUN Hold
#2 OFF Awaiting Load

Leaving Water Temp - Cool
Sets control target for evaporator leaving water temperature in COOL mode.
35 to 80 Deg F
2 to 26 Deg C

SETPOINTS		WATER	
°F - PSI			
Templifier Source Reset	80	15	STARTER
Templifier Source No Start	70	14	TIMERS
Maximum Reset Delta T	10.0	13	
Start Reset Delta T	0.0	12	ALARMS
LWT Reset Type	None	11	
Stage Delta T	1.0	10	VALVE
Startup Delta T	3.0	9	
Shutdown Delta T	3.0	8	TOWER
Leaving Water Temp - Heat	135.0	7	
Leaving Water Temp - Ice	25.0	6	MOTOR
Leaving Water Temp - Cool	44.0	5	
		4	MODES
		3	
		2	WATER
		1	

7 8 9 CANCEL
4 5 6 UP
1 2 3 DOWN
0 . +/- ENTER

HISTORY VIEW SET CHANGE

Table 19, WATER Setpoint Settings

Description	NO.	Default	Range	Pass word	Comments
Templifier Source Water Reset (Delta-T)	11	55°F	50 to 100 °F	T	Resets the condenser leaving temperature downward if source leaving drops under the delta-T. Setting is a function of comp selection.
Templifier Source No Start	10	70°F	50 to 100°F	T	Entering source water temperature below which the unit cannot start.
Max Reset Delta T	9	0.0°F	0.0 to 20.0 °F	M	Set the maximum reset that can occur, in degrees F if LWT reset is selected or max reset at 20 mA input if 4-20 mA is selected in SP7
Start Reset Delta T	8	10. 0°F	0.0 to 20.0 °F	M	Sets the evap delta-T above which Return reset begins.
LWT Reset Type	7	NONE	NONE, RETURN, 4-20mA	M	Select reset type, NONE for none, RETURN for resetting chilled water based on the entering water, or 4-20 mA for external analog signal
Stage Delta T	6	1	0.5 to 5°F	M	Sets the temperature the leaving water must be below setpoint for next compressor to start.
Startup Delta T	5	3.0°F	0.0 to 10.0 °F	M	Degrees above setpoint for compressor to start.
Shutdown Delta T	4	3.0°F	0.0 to 3.0 °F	M	Degrees below setpoint for compressor to stop.
Heat LWT	1	135. 0°F	100.0 to 150.0 °F	M	Condenser LWT setpoint in HEAT (Templifier) mode
Ice LWT	2	25. 0°F	15.0 to 35.0 °F	M	Evaporator LWT setpoint in the ICE mode
Cool LWT	3	44. 0°F	35.0 to 80.0 °F	M	Evaporator LWT setpoint in COOL mode

SERVICE Screen

Figure 21, Service Screen

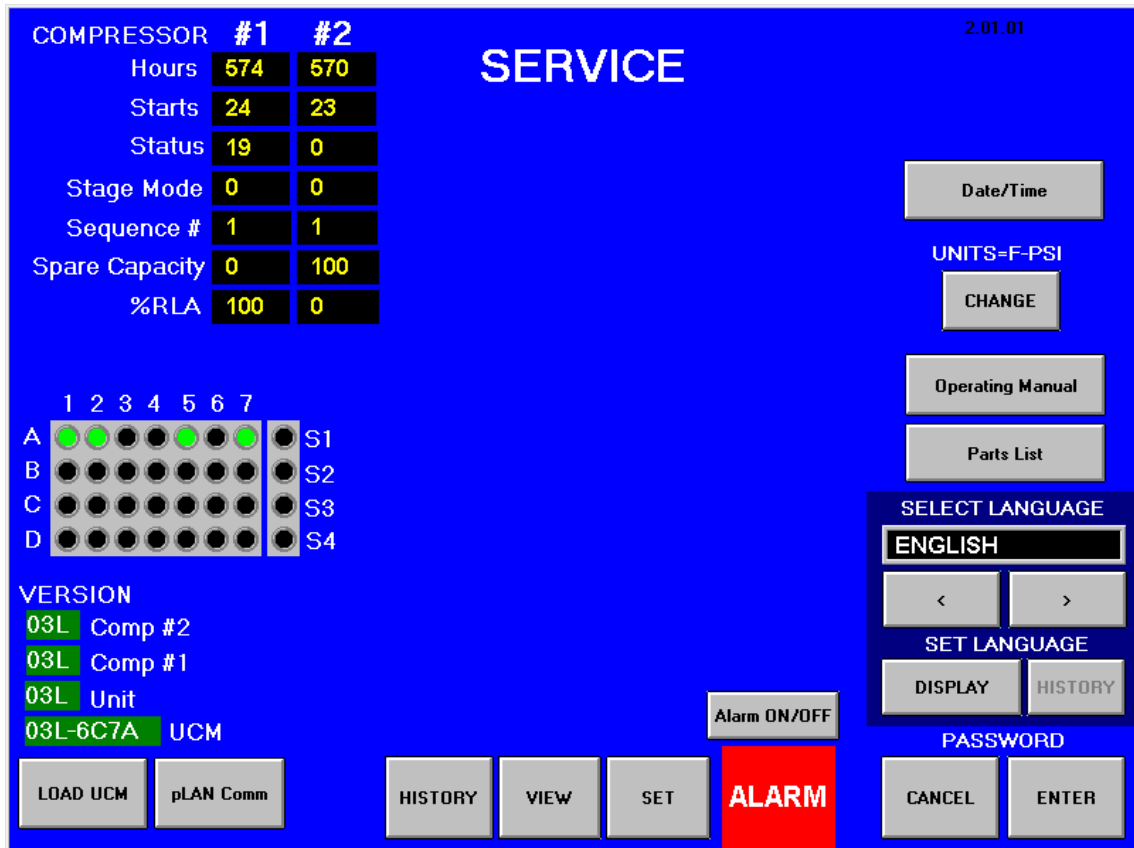

Pressing SET from any SET screen accesses the SERVICE screen. In other words, it is the second "SET" screen. While containing information and activity buttons for the service technician, it also has valuable information for the operator.

The upper left corner contains compressor information as shown above. The screen illustrated is for a dual compressor unit, a single, of course, would show data for only one compressor. "Spare Capacity" is used to set the compressor stopping increment for dual compressors.

The light matrix below it displays what nodes are active for chillers A, B, C, and D on the pLAN.

The software version numbers shown in the lower left corner are the controllers' software identification. These numbers may be required by McQuay to answer questions about unit operation or to assist in possible future upgrades of software. The OITS software number is shown in the upper-right corner.

The Operating Manual button will access the operating and maintenance manual for the unit. The unit will also have a Parts Manual button. Some early versions may not have a parts list loaded. A McQuay service technician can upload it. Pressing these buttons will display the manual on the screen where it can be manipulated as an Adobe Acrobat file®.

SELECT LANGUAGE allows toggling between the available languages. The language can be set separately for display or history, which is used for alarm and trend files.

The PASSWORD button is used to access the Keyboard screen to enter a password.

The Alarms ON/OFF button is normally used only on demonstration software and will probably not appear on the unit's screen. If so, they should be ignored.

The LOAD UCM and pLAN Comm buttons are for use only by authorized service technicians.

Date/Time in the upper-right corner is pressed to set the correct date and time, if needed.

HISTORY Screens

Figure 22, History Trend Graph

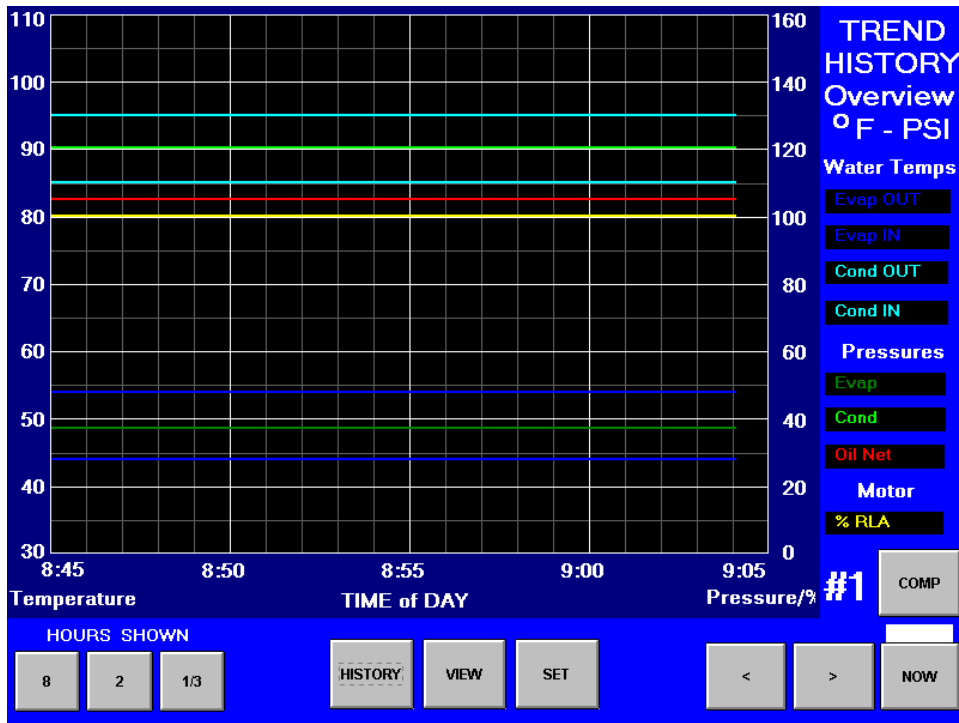

The Trend History Overview allows the user to view the various parameters listed on the right side of the screen. The temperature scale in °F (°C) is on the left. Pressure in psi (kPa) and % RLA are represented by the right-hand scale. The screen can display history for 8 hour, 2 hour or 20-minute periods by pressing 8, 2, or 1/3 respectively. Some software versions have a 24 hour instead of an 8 hour period.

Pressing NOW for any time period will start the display for the current time beginning on the right of the screen with history flowing to the left.

The arrow buttons scroll the time period forward or backward. Obviously if NOW is selected, the forward button > will not go into the future.

Figure 23, Alarm History/USB Download

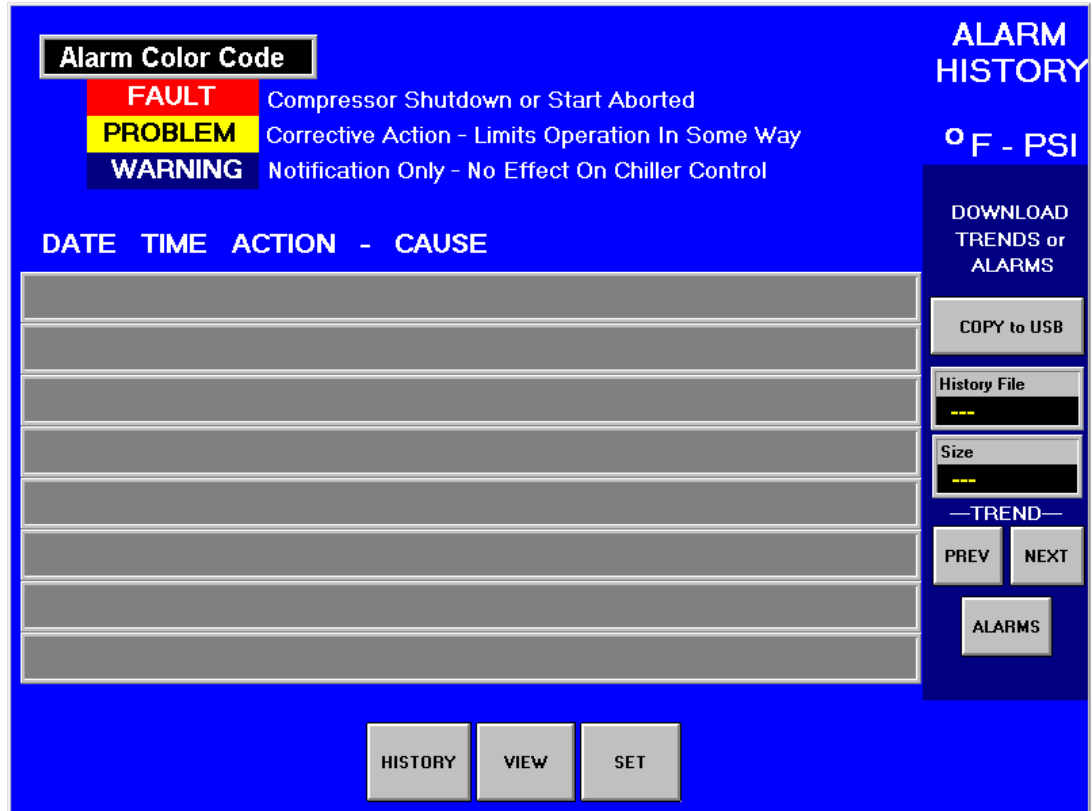

The Alarm History lists the alarms with the most current on top with date stamp, action taken and the cause of the alarm. The alarms are color-coded as shown on the top of the screen.

Download from the USB

This screen is also used to download the Trend History (Figure 22) selected by date *or* the Alarm History shown above. To download, connect a USB portable storage device to the USB port located in the unit control panel adjacent to the OITS, and:

- For Alarms, press the ALARMS button on the screen, then press the COPY to USB button.
- For Trend History, select the desired History File by date using the PREV or NEXT buttons, then press the COPY to USB button.

ACTIVE ALARM Screen

Figure 24, Active Alarms

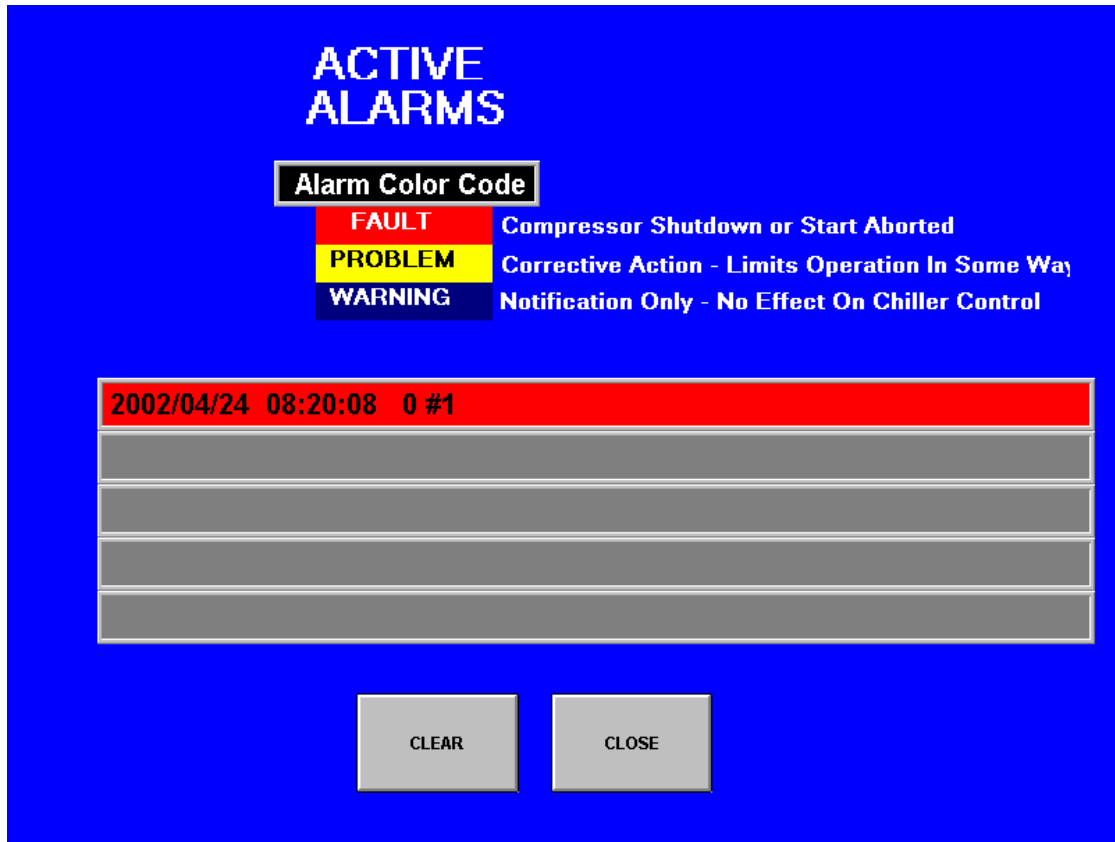

The Active Alarm screen is accessible when an active alarm exists on the unit by pressing the red alarm signal on any screen. If no alarm is active, it can be accessed from the SERVICE screen by pressing the blue square where the red alarm signal would be. This allows repeating the alarm clear command if desired.

Alarms are arranged in order of occurrence, with the most recent on top. Once the abnormal condition is corrected, pressing the "CLEAR" key will clear the alarm.

The current active alarms (there may be more than one) are displayed. Note that the alarms are color-coded red for FAULT (equipment protection control) that causes a rapid compressor shutdown, yellow for PROBLEM (limit alarm) that will inhibit loading, or load or unload the compressor, and blue for WARNING which is information only and takes no action.

The date/time and cause of the alarm are displayed.

After eliminating the cause of the alarm, clear the alarm by pressing the CLEAR button. This will clear the alarm from the register and allow the unit to restart after going through the start sequence. The alarm notice will be deleted from the screen.

However, if the cause of the alarm is not remedied, the alarm is still active and the alarm message will remain on screen. The unit will not begin its starting sequence.

Always remedy the cause of an alarm before attempted to clear it.

Alarms fall into three distinct categories: Faults, Problems, and Warnings as detailed in the following section.

Fault Alarms

The following table identifies each fault alarm, its display, gives the condition that causes the alarm to occur, and states the action taken because of the alarm. All fault alarms require a manual reset.

Table 20, Fault Alarm Description

Description	Display	Occurs When:	Action Taken
Low Evaporator Pressure	<u>Evap Pressure Low</u>	Evaporator Press < Low Evap Pressure SP	Rapid Stop
High Condenser Pressure	<u>Condenser Press High</u>	Cond Press > High Condenser Pressure SP	Rapid Stop
Vanes Open No Start	<u>Vanes Open</u>	Compressor state = PRELUBE for 30 sec after Prelube timer expires	Rapid Stop
Low Oil Delta Pressure	<u>Oil Delta Pressure Low</u>	(Comp State=PRELUBE, RUN, UNLOAD, or POSTLUBE) & Net Oil Press < Low Net Oil Press SP	Rapid Stop
Low Oil Feed Temperature	<u>Oil Feed Temp Low</u>	(Comp State=RUN or UNLOAD) & Oil Feed temp < (Evap Saturated Refr Temp + Low Oil Delta Temperature SP) for > 1 min	Rapid Stop
High Oil Feed Temperature	<u>Oil Feed Temp High</u>	Temp > High Oil Feed Temperature SP	Rapid Stop
Low Motor Current	<u>Motor Current Low</u>	I < Motor Current Threshold with Compressor ON for 30 sec	Rapid Stop
High Discharge Temperature	<u>Disch Temp High</u>	Temp > High Discharge Temperature SP	Rapid Stop
Mechanical High Pressure	<u>Mechanical High Press</u>	Digital Input = High Pressure	Rapid Stop
High Motor Temperature	<u>High Motor Temp</u>	Digital Input = High Temperature	Rapid Stop
Surge Temp High	<u>Surge Temperature</u>	Surge Temp > Surge Temp SP	Rapid Stop
Surge Temp Slope High	Note 1	Surge Temp Slope > Surge High Slope SP	Rapid Stop
Compressor Surge Eminent	<u>Surge Switch</u> Note 2	Delta-P Switch Senses Reverse Pressure Across the Discharge Check Valve	Rapid Stop
No Starter Transition	<u>No Starter Transition</u>	Starter Transition Digital Input = No Transition AND Compressor ON for > 15 seconds	Rapid Stop
No Compressor Stop	<u>Current High with Comp Off</u>	%RLA > Motor Current Threshold SP with Compressor OFF for 30 sec	Annunciation
Starter Fault	<u>Starter Fault</u>	Starter Fault Digital Input = Fault AND Compressor State = START, PRELUBE, RUN, or UNLOAD	Rapid Stop
Low Oil Pressure Start	<u>Oil Pressure Low-Start</u>	Compressor State = START for 30 sec	Rapid Stop
No Evaporator Water Flow	<u>Evaporator Water Flow Loss</u>	Chilled Water Flow Switch Open	Rapid Stop
No Condenser Water Flow	<u>Condenser Water Flow Loss</u>	Condenser Water Flow Switch Open	Rapid Stop
Leaving Evaporator Water Temperature Sensor Fault	<u>Evap LWT Sensor Out of Range</u>	Sensor shorted or open	Rapid Stop
Evaporator Pressure Sensor Fault	<u>Evap Pressure Sensor Out of Range</u>	Sensor shorted or open	Rapid Stop
Condenser Pressure Sensor Fault	<u>Cond Pressure Sensor Out of Range</u>	Sensor shorted or open	Rapid Stop
Suction Temperature Sensor Fault	<u>Suction Pressure Sensor Out of Range</u>	Sensor shorted or open	Rapid Stop
Discharge Temperature Sensor Fault	<u>Discharge Temp Sensor Out of Range</u>	Sensor shorted or open	Rapid Stop
Oil Feed Temperature Sensor Fault	<u>Oil Feed Temp Sensor Out of Range</u>	Sensor shorted or open	Rapid Stop
Oil Sump Temperature Sensor Fault	<u>Oil Sump Temp Sensor Out of Range</u>	Sensor shorted or open	Rapid Stop
Oil Feed Pressure Sensor Fault	<u>Oil Feed Pressure Sensor Out of Range</u>	Sensor shorted or open	Rapid Stop
Oil Sump Pressure Sensor Fault	<u>Oil Sump Pressure Sensor Out of Range</u>	Sensor shorted or open	Rapid Stop

NOTES:

1. Surge Temperature is defined as the suction temperature minus the leaving chilled water temperature.
2. Delta-P switch used only on chillers manufactured in Europe.
3. Starter alarm faults will be sent from the starter and will also appear here. They are discussed elsewhere in this manual.

Problem Alarms

The following alarms do not cause compressor shutdown but limit operation of the chiller in some way as described in the Action Taken column. A limit alarm will trigger the red alarm screen and the digital output for the optional remote alarm.

Table 21, Problem Alarm Description

Description	Display	Occurs When:	Action Taken	Reset
Low Evaporator Pressure – Inhibit Loading	<u>Lo Evap Press-NoLoad</u>	Pressure < Low Evap Pressure–Inhibit setpoint	Inhibit loading	Evap Press rises above (SP + 3psi)
Low Evaporator Pressure – Unload	<u>Low Evap Press-Unload</u>	Pressure < Low Evap Pressure–Unload setpoint	Unload	Evap Press rises above (SP + 3psi)
Evaporator Freeze Protect	<u>Evap Pres Lo-Freeze</u>	Evap Sat Refr Temp < Evaporator Freeze SP	Start evaporator pump	Temp > (Evaporator Freeze SP + 2°F)
Condenser Freeze Protect	<u>Cond Pres Lo-Freeze</u>	Cond Sat Refr Temp < Condenser Freeze SP	Start condenser pump	Temp > (Condenser Freeze SP + 2°F)
High Discharge Temperature	<u>High Discharge T-Load</u>	Temperature > High Discharge Temperature-Load SP AND Suction superheat < 15°F	Load	Temp < (High Dsch Temp Load SP – 3°F) OR Superheat > 18°F

Warning Alarms

A warning is announced whenever an abnormal condition exists which does not affect chiller operation.

Table 22, Warning Alarm Description

WARNING	DISPLAY	CONDITION
Liquid Line Refrigerant Temperature Sensor Fail Warning	Liq Line T Sen Warn	Sensor is shorted or open
Entering Evaporator Water Temperature Sensor Fail Warning	Ent Evap T Sen Warn	Sensor is shorted or open
Leaving Condenser Water Temperature Sensor Fail Warning	Lvg Cond T Sen	Sensor is shorted or open
Entering Condenser Water Temperature Sensor Fail Warning	Ent Cond T Sen	Sensor is shorted or open

Figure 25, Keyboard

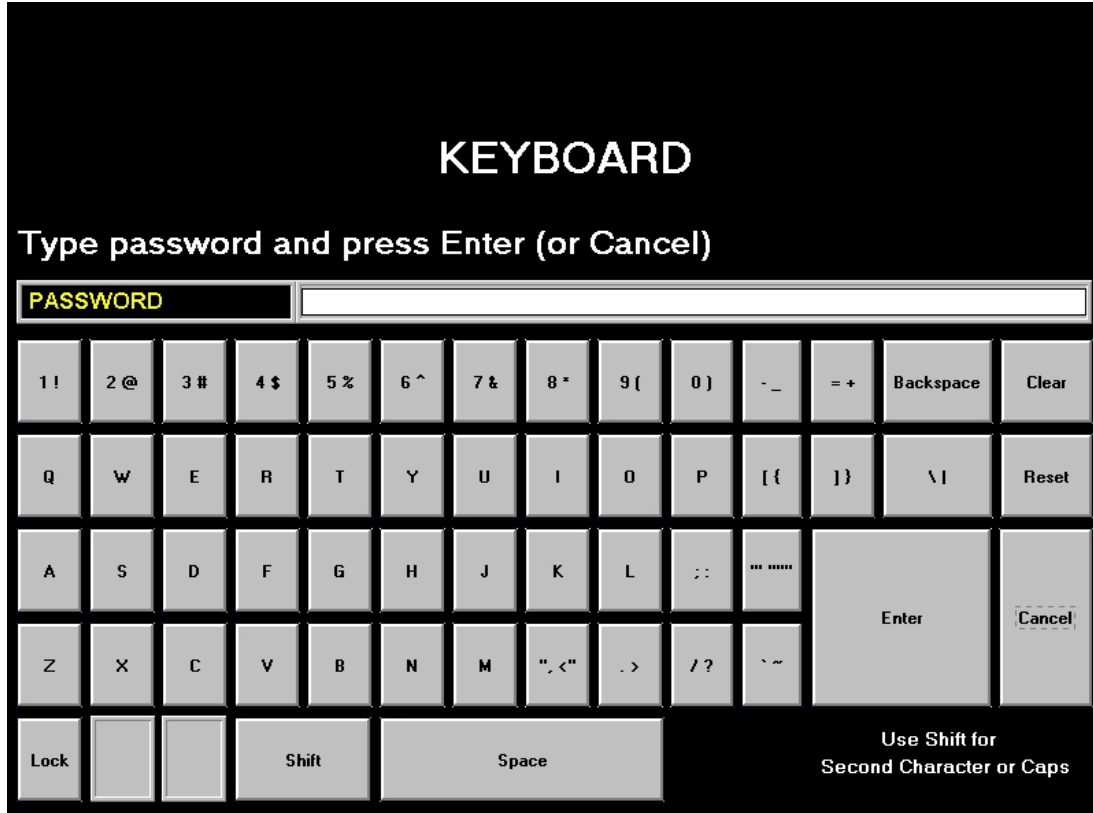

The keyboard is for entering the password when attempting to enter or change a setpoint. This screen is accessed from the SERVICE screen by pressing the PASSWORD button. It is automatically accessed when making a change to a setpoint on any SET screen.

Unit Controller

A general description of the unit controller with its inputs and outputs is on page 7. This section will describe the operation of the unit controller, define the screen hierarchy and how to navigate through it and also give a description of the screens.

4x20 Display & Keypad

Layout

The 4-line by 20-character/line liquid crystal display and 6-key keypad are shown below.

Figure 26, Display (in MENU mode) and Keypad Layout

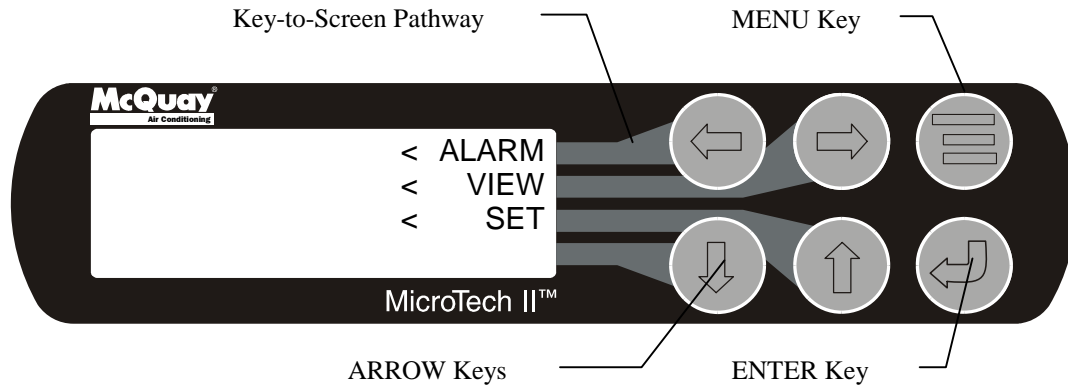

Note that each ARROW key has a pathway to a line in the display. Pressing an ARROW key will activate the associated line when in the MENU mode.

Getting Started

There are two basic procedures to learn in order to utilize the MicroTech II controller:

1. Navigating through the menu matrix to reach a desired menu screen and knowing where a particular screen is located.
2. Knowing what is contained in a menu screen and how to read that information or how to change a setpoint contained in the menu screen.

Navigating

The menus are arranged in a matrix of screens across a top horizontal row. Some of these top-level screens have sub-screens located under them. The general content of each screen and its location in the matrix begins in Figure 28 on page 44. A detailed description of each menu screen begins on page 46.

There are two ways to navigate through the menu matrix to reach a desired menu screen.

- 1) One is to scroll through the matrix from one screen to another using the four ARROW keys.
- 2) Another way is to use shortcuts to work through the matrix hierarchy. From any menu screen,
 - a) Pressing the MENU key will take you to the top level of the hierarchy. The display will show ALARM, VIEW, and SET. One of these groups of screens can then be selected by pressing the key connected to it via the pathway.

- b) Depending on the top-level selected, a second level of screens will appear. For example, selecting ALARM will go the next level of menus under ALARM (ALARM LOG or ACTIVE ALARM). Selecting VIEW will go the next level of menus (VIEW COMPRESSOR STATUS, VIEW UNIT STATUS, VIEW EVAPORATOR, or VIEW CONDENSER). Selecting SET will go to a series of menus for looking at and changing setpoints.
- c) After selecting this second level, the desired screen can be acquired using the arrow keys. A typical final screen is shown below.

Pressing the MENU key from any menu screen will automatically return you to the MENU mode.

Figure 27, Typical Menu Display and Keypad Layout

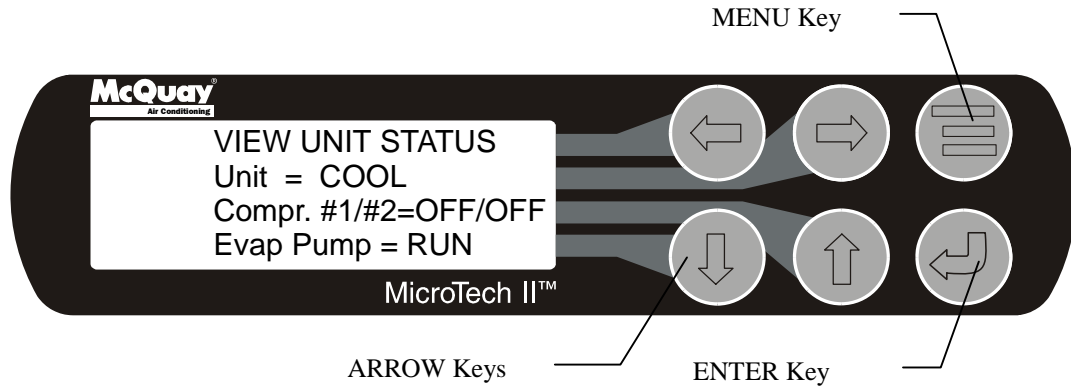

Screen Content

Figure 28, View Screens

VIEW UNIT STATUS (1) Unit = COOL Compressor 1=X Ev/Cn Pmps=/ Cond	VIEW UNIT WATER °F (1). In Out Delta Evap Cond	VIEW UNIT REFRG (1) psi F Sat Evap Sat Cond	VIEW UNIT TOWER(1) Stages ON= of EntCondTemp= Setpoint=	VIEW COMP #1 (1) State = % RLA = % Evap LWT = °F	VIEW COMP #2 (1) State = % RLA = % Evap LWT = °F	VIEW EVAPORATOR Suct SH = Approach =	VIEW CONDENSER Disch SH = Approach = Subcooling=
VIEW UNIT STATUS (2) Compressor 2=X Start-Start Tmr= Inhibit Oil Temp	VIEW UNIT WATER °F (2) In Out Delta HtRc Cond XX XX XX	VIEW UNIT REFRG (2) Suct Line = Liquid Line = Lift Press =	VIEW UNIT TOWER(2) Bypass Valve = VFD Speed =	VIEW COMP (2) Cond Press = Evap Press = Lift Press =	VIEW COMP #2 (2) Cond Press = Evap Press = Lift Press =		
	VIEW UNIT WATER (3) Water Flo Rates Evap = XXX Cond = XXX			VIEW COMP (3) Feed Press = Sump Press = Net Press =	VIEW COMP #2 (3) Vent Press = Feed Press = Net Press =		
				VIEW COMP (4) Sump Temp = Feed Temp = Lift Temp	VIEW COMP #2 (4) Sump Temp = Feed Temp = Lift Temp		
				VIEW COMP (5) Temp SH Suction °F °F Dischrg °F °F	VIEW COMP #2 (5) Temp SH Suction °F °F Dischrg °F °F		
				VIEW COMP (6) Psi °F Sat Evap Sat Cond	VIEW COMP #2 (6) Psi °F Sat Evap Sat Cond		
				VIEW COMP (7) Hours = Starts =	VIEW COMP #2 (7) Hours = Starts =		

Alarm Screens

ALARM LOG (1) Description Time Date	ACTIVE ALARM Time Date Fault Description....
ALARM LOG (2) Description Time Date	
ALARM LOG (N) Description Time Date	

Set Screens

SET UNIT SPs (1) Enable = Mode = Source =	SET COMP #1SPs (1) Demand Limit= Minimum Amps = % Maximum Amps= %	SET COMP#2 SPs (1) Demand Limit= Minimum Amps= % Maximum Amps= %	SET ALARM SPs (1) LowEv PrHold = Low Ev Pr Unld = Low Ev Pr Stop =	SET TOWER SPs (1) TowerControl-Temp = TowerStages = StageUp/Dn = xxx/xxx
SET UNIT SPs (2) Available Modes Select w/Unit Off	SET COMP SPs (2) StageMode = StageSequence# = Max Compr ON =	SET COMP#2 SPs (2) StageMode = StageSequence# = Max Compr ON =	SET ALARM SPs (2) High Cond Pr = HiDiscT-Load = HiDiscT-Stop =	SET TOWER SPs (2) StageOn(Temp) °F #1 #2 #3 #4 xxx xxx xxx xxx
SET UNIT SPs (3) Cool LWT = Ice LWT = Heat LWT =	SET COMP SPs (3) StageDeltaT = Stop-Start = min Start-Start = min	SET COMP#2 SPs (3) StageDeltaT = Stop-Start = min Start-Start = min	SET ALARM SPs (3) High HiOilFeedTemp = LowOilDeltaT = LowNetOilPr =	SET TOWER SPs (3) StageDiff = StageUp = StageDown =
SET UNIT SPs (4) Leaving Water Temp. StartDelta = StopDelta =	SET COMP SPs (4) Full Load = sec	SET COMP#2 SPs (4) Full Load = sec	SET ALARM SPs (4) Surge Slp Str = XX°F Surge Temp Run=XX°F MtrCurrThrsld =	SET TOWER SPs (4) Valve/VFDControl = ValveSp/VFDStage ValveType =
SET UNIT SPs (5) Rest Type = Max Reset DT = Strt Reset DT =	SET COMP SPs (5) OilNoStrtDiff= Abs Capacity = T HotGasBypass = %	SET COMP#2 SPs (5) OilNoStrtDiff= Abs Capacity = T HotGasBypass = %	SET ALARM SPs (5) EvapFreeze = CondFreeze =	SET TOWER SPs (5) Valve SP = Valve DB =
SET UNIT SPs (6) Soft Load = BeginAmpLimit = SoftLoadRamp =	SET COMP SPs (6) Unload Timer = sec PreLubeTmrs= sec PostLub Tmrs= sec	SET COMP#2 SPs (6) Unload Timer = sec PreLubeTmrs= sec PostLub Tmrs= sec		SET TOWER SPs (6) Valve Start Position Min = xxx% @ xxx°F Max = xxx% @ xxx°F
SET UNIT SPs (7) Max/Min LWT Rates Max = /min Min = /min	SET COMP SPs (7) VaneMode = Vanes = %RLA= %	SET COMP#2 SPs (7) VaneMode = Vanes = %RLA= %		SET TOWER SPs (7) Valve Control Range Min = % Max = %
SET UNIT SPs (8) EvapRecTmr = min EvapPump = CondPump =	SET COMP SPs (8) VFD Mode = VFD = % %RLA = %	SET COMP#2 SPs (8) VFD Mode = VFD = % %RLA = %		SET TOWER SPs (8) PD Control Loop Error Gain = % Slope Gain = %
SET UNIT SPs (9) Templifier Src Water No start = 70°F Delta Reset=055°F	SET COMP SPs (9) Protocol = MODBUS Id #=001 Units=IP Baud Rate=19200	SET COMP SPs (9) Protocol = MODBUS Id #=001 Units=IP Baud Rate=19200		
SET UNIT SPs (10) VFD = Min Speed = % Spd/Lift = %/	SET COMP SPs (10) Refrig Sat Pressure Evap Offset = 00.0 psi Cond Offset = 00.0 psi	SET COMP SPs (10) Refrig Sat Pressure Evap Offset = 00.0 psi Cond Offset = 00.0 psi		
SET UNIT SPs (11) Max Water Flow Rates Evap WF = XXXXX GPM Cond WF = XXXXX GPM	SET COMP SPs (11) ELWT Offset = 0.0°F Oil Sump OS = 00.0 psi Oil Feed OS = 00.0 psi	SET COMP SPs (11) ELWT Offset = 0.0°F Oil Sump OS = 00.0 psi Oil Feed OS = 00.0 psi		
SET UNIT SPs (12) Standard Time 17/March/2005 12:20 THU				
SET UNIT SPs (13) Display Format Units = F/psi (IP) Lang = English				
SET UNIT SPs (14) Protocol = MODBUS Id #=001 Units=IP Baud Rate=19200				
SET UNIT SPs (15) Ex-Valve Gain = 100 Offset(Slope) = 271 Pr Ctrl Dout = 10°F				

Screen Descriptions

VIEW Screens

VIEW Screens are only for viewing the operation of the unit and compressors. No data is input into VIEW Screens. The controllers' screens are only in °F/psi. When the Display Units set point is set to °C/kPa, the units of measure on the OITS only will change.

View Unit Status (Single Compressor)

```
VIEW UNIT STATUS (1)
Unit=COOL
Compressor=LOAD
Ev/Cn Pmps=STRT/RUN
```

```
VIEW UNIT STATUS (2)
Compressor=LOAD
Start-Start Tmr Clr
Inhibit Oil Temp Low
```

Unit status can be OFF, COOL, ICE, HEAT, and ALARM as determined from the Unit State variable, the Unit Mode setpoint, the Unit Enable and the presence of a shutdown alarm. Compressor states can be OFF, START, PRELUBE, HOLD, LOAD, UNLOAD, POSTLUBE, and ALARM as determined from the Comp State variable and the Load and Unload outputs, and the presence of a compressor shutdown alarm. Evap and Cond Pump states can be OFF, STRT (start), & RUN.

View Unit Status (Dual Compressor)

```
VIEW UNIT STATUS (3)
Unit=COOL
Cmp1/2= LOAD /POSTLB
Ev/Cn Pmps=STRT/RUN
```

This screen is only viewable on dual compressor units. Unit states can be OFF, COOL, ICE, HEAT, and ALARM as determined from the Unit State variable, the Unit Mode setpoint, and the presence of a unit shutdown alarm. Compressor states can be OFF, START, PRELB, HOLD, LOAD, UNLOAD, POSTLB, and ALARM as determined from the Comp State variable, the Load and Unload outputs, and the presence of a compressor shutdown alarm. Evap and Cond Pump states can be OFF, STRT (start), & RUN.

View Unit Water

```
VIEW UNIT WATER °F(1)
   In   Out  Delta
Evap XX.X XX.X  XX.X
Cond XX.X XX.X  XX.X
```

```
VIEW UNIT WATER °F(2)
   In   Out  Delta
HtRc NA   NA
Cond XX.X XX.X  XX.X
```

HT RC will only show temperatures if the unit has a heat recovery bundle with sensors, otherwise it will show NA. Cond is the tower condenser, which will always be present.

```

VIEW UNIT WATER °F(3)
Water Flow Rates
Evap = XXXX GPM
Cond = XXXX GPM

```

View Unit Refrigerant

```

VIEW UNIT REFRG (1)
           psi    °F
Sat Evap XXX.X  XX.X
Sat Cond XXX.X  XX.X

```

```

VIEW UNIT REFRG (2)
Suct Line = XXX.X°F
Liquid Line= XXX.X°F
Lift Press =XXX.Xpsi

```

View Unit Tower

Tower Control = Temp/None	Tower Control = Lift
VIEW UNIT TOWER (1)	VIEW UNIT TOWER (1)
Stages ON = 2 of 4	Stages ON = 2 of 4
Setpoint = XXX °F	Setpoint = XXXX psi

The first Stages ON value is the number of fan stages ON. The second number is the Tower Stages set point, i.e. the number of stages set, selectable from 0 to 4 (0 if Tower Control = None). The bottom line is the setpoint, °F or psi will show on the screen depending on whether TEMP (°F) or LIFT (psi) is selected in the Cooling Tower Control setpoint.

```

VIEW UNIT TOWER (2)
Bypass Valve = XXX%
VFD Speed    = XXX%

```

The Bypass Valve value is “None” (in place of XXX%) if the Valve/VFD Control set point = None or VFD Stage. The VFD Speed value is “None” if the Valve/VFD Control set point = None, Valve Setpoint, or Valve Stage.

View Compressor

NOTE: In the following VIEW COMP screens, the #N field indicates which compressor (#1, and #2 for dual compressor units.) is being viewed.

```

VIEW COMP#N (1)
State = RUN
% RLA = XXX %
Evap LWT = °F

```

State settings can be OFF, START, PRELUBE, HOLD, LOAD, UNLOAD, SHUTDOWN, POSTLUBE, and ALARM as determined from the Comp State variable, the Load and Unload outputs, and the presence of a compressor shutdown alarm. #N is for compressor #1 or #2 on dual compressor units and does not appear on single compressor units.

```
VIEW COMP#N (2)
Cond Press =
Evap Press =
Lift Press =
```

```
VIEW COMP#N (3)
Feed Press =XXXX psi
Sump Press =XXXX psi
Net Press = XXX psi
```

```
VIEW COMP#N (4)
Sump Temp = XXX.X°F
Feed Temp = XXX.X°F
Lift Temp = XXX.X°F
```

Lift Temp is the difference in suction and discharge saturated temperatures.

```
VIEW COMP#N (5)
           Temp SH
Suction   xxx°F xx°F
Discharge xxx°F xx°F
```

```
VIEW COMP#N (6)
           Psi °F
Sat Evap=XXX.X XXX.X
Sat Cond=XXX.X XXX.X
```

```
VIEW COMP#N (7)
Hours = XXXX x 10
Starts =XXXX
```

View Evaporator

```
VIEW EVAPORATOR
Suct SH = XXX.X °F
Approach = XX.X °F
```

View Condenser

```
VIEW CONDENSER
Disch SH = XXX.X °F
Approach = XX.X °F
Subcooling= XX.X °F
```

View ALARM Screens

View Alarm Log

```
ALARM LOG (1)
Alarm Description
hh:mm:ss dd/mmm/yyyy
```

```
ALARM LOG (2-25)
Alarm Description
hh:mm:ss dd/mmm/yyyy
```

The ALARM LOG contains a description and time stamp on the last 25 alarms

Active Alarm Screen

Active Alarms

```
ALARM ACTIVE (1)
Alarm Description
hh:mm:ss dd/mmm/yyyy
<Press Edit to CLEAR
```

The alarm screen is viewable only when there is one or more uncleared alarms active. See page 98 for instructions on clearing alarms.

SET Screens

The PW (password) column indicates the password that must be active in order to change the set point. Codes are as follows:

O = Operator, password is 100 M = Manager, password is 2001 T = Technician (reserved)

The operator password is entered as 100 (three digits) on the OITS graphic keyboard. When entered on a microprocessor LCD screen, four digits are required, thus it is entered as 0100.

Editing Setpoints

In order to enter or change a setpoint, the appropriate screen must first be accessed. There are two ways to get to the desired menu screen:

1. Scrolling, The scroll method allows the user to move about the matrix (from one menu to another, one at a time) by using the four ARROW keys. The menu matrix begins in Figure 28 on page 44.
2. The MENU key can be used as a shortcut to specific groups of menus within the matrix.

Pressing the MENU key from any menu screen will automatically return you to the MENU mode.

Editing is accomplished by pressing the ENTER key until the desired field is selected. This field is indicated by a blinking cursor under it. The arrow keys will then operate as defined below.

Right Arrow Key = CANCEL Reset the current field to the value it had when editing began.

Left Arrow Key = DEFAULT Set value to original factory setting.

Up Key = INCREMENT Increase the value or select the next item in a list.

Down Key = DECREMENT Decrease the value or select the previous item in a list.

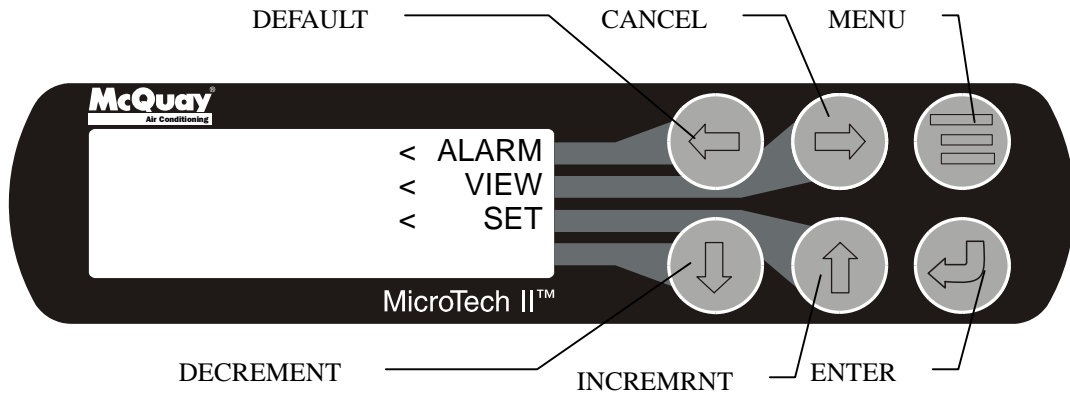

These four edit functions are indicated by one-character abbreviation on the right side of the display (this mode is entered by pressing the ENTER key).

Most menus containing set point values have several different setpoints shown on one menu. When in a setpoint menu, the ENTER key is used to proceed from the top line to the second line and on downward. The cursor will blink at the entry point for making a change. The ARROW keys (now in the edit mode) are used to change the set point as described above. When the change has been made, press the ENTER key to enter it. Nothing is changed until the ENTER key is pressed.

For example, to change the chilled water setpoint:

1. Press MENU key to go to the MENU mode.
2. Press SET (the UP Key) to go to the setpoint menus.
3. Press UNIT SPs (the Right key) to go to setpoints associated with unit operation.
4. Press the DOWN key to scroll down through the setpoint menus to the third menu screen which contains Cool LWT=XX.X°F.
5. Press the ENTER key to move the cursor down from the top line to the second line in order to make the change. If a password is not active, the control will automatically go to the Set PASSWORD screen
6. Use the ARROW keys (now in the edit mode as shown above) to change the setting.
7. When the desired value is achieved, press ENTER to enter it and also move the cursor down.

At this point, the following actions can be taken:

1. Change another setpoint in this menu by scrolling to it with the ENTER key.
2. Using the ENTER key, scroll to the first line in the menu. From there the ARROW keys can be used to scroll to different menus.

During edit mode, the display will show a two-character wide menu pane on the right as shown below. They stand for; Default, Cancel, (+) Increase, (-) Decrease

SET UNIT SPs (X)	<D
(data)	<C
(data)	<+
(data)	<-

Additional fields can be edited by pressing the ENTER key until the desired field is selected. When the last field is selected, pressing the ENTER key switches the display out of “edit” mode and returns the arrow keys to “scroll” mode.

Unit Controller Setpoints

Table 23, Unit Setpoints

Description	Default	Range	PW
Unit			
Unit Enable	OFF	OFF, ON	O
Unit Mode	COOL	COOL, ICE, HEAT, TEST	O T
Available Modes	COOL	COOL, COOL/ICE, ICE, COOL/HEAT, HEAT	T
Mode Source	Local	LOCAL, BAS, SWITCH	O
Display Units	°F/psi	°F/psi	O
Language	ENGLISH	ENGLISH, (TBD)	O
BAS Protocol	NONE	LOCAL, REMOTE, BACnet MSTP, BACnet ETHERNET, BACnet TCP/IP, MODBUS	M
Hot Gas Mode	OFF	OFF, %RLA, LWT	M
Hot Gas Control Point	30%	20 to 70%	M
Leaving Water			
Cool LWT	44.0°F	35.0 to 80.0 °F	O
Ice LWT	25.0°F	15.0 to 35.0 °F	O
Heat LWT	135.0°F	100.0 to 150.0 °F	O
Startup Delta T	3.0°F	0.0 to 10.0 °F	O
Shutdown Delta T	3.0°F	0.0 to 3.0 °F	O
LWT Reset Type	NONE	NONE, RETURN, 4-20mA	M
Max Reset Delta T	0.0°F	0.0 to 20.0 °F	M
Start Reset Delta T	10.0°F	0.0 to 20.0 °F	M
Electronic Expansion Valve			
Ex Valve Gain	100	50 to 400	M
Offset (Slpoe)	271	100 to 999	M
Prs Ctrl DOut	10°F	0 to 99.9°F	M
Templifier			
Source Water Reset	80 °F	50 to 100 °F	T
Timers			
Evap Recirculate	30 sec	0.2 to 5 min	M
Pumps			
Evap Pump	Pump #1 Only	Pump #1 Only, Pump #2 Only, Auto Lead, #1 Primary, #2 Primary	M
Cond Pump	Pump #1 Only	Pump #1 Only, Pump #2 Only, Auto Lead, #1 Primary, #2 Primary	M
Cooling Tower			
Tower Control	None	None, Temperature, Lift	M
Tower Stages	2	1 to 4	M
Stage Up Time	2 min	1 to 60 min	M
Stage Down Time	5 min	1 to 60 min	M
Stage Differential (Temp)	3.0 °F	1.0 to 10.0 °F	M
Stage Differential (Lift)	6.0 psi	1.0 to 20.0 psi	M
Stage #1 On (Temp)	70 °F	40 to 120 °F	M
Stage #2 On (Temp)	75 °F	40 to 120 °F	M
Stage #3 On (Temp)	80 °F	40 to 120 °F	M
Stage #4 On (Temp)	85 °F	40 to 120 °F	M
Stage #1 On (Lift)	35 psi	10 to 130 psi	M
Stage #2 On (Lift)	45 psi	10 to 130 psi	M
Stage #3 On (Lift)	55 psi	10 to 130 psi	M
Stage #4 On (Lift)	65 psi	10 to 130 psi	M
Cooling TowerValve / VFD			
Valve/VFD Control	None	None, Valve Setpoint, Valve Stage, VFD Stage, Valve SP/VFD Stage	M
Valve Setpoint (Temp)	65 °F	40 to 120 °F	M
Valve Setpoint (Lift)	30 psi	10 to 130 psi	M
Valve Deadband (Temp)	2.0 °F	1.0 to 10.0 °F	M
Valve Deadband (Lift)	4.0 psi	1.0 to 20.0 psi	M

Continued next page.

Description	Default	Range	PW
Stage Down @	20%	0 to 100%	M
Stage Up @	80%	0 to 100%	M
Valve Control Range (Min)	10%	0 to 100%	M
Valve Control Range(Max)	90%	0 to 100%	M
Valve Type	NC To Tower	NC, NO	M
Minimum Start Position	0%	0 to 100%	M
Minimum Position @	60 °F	0 to 100 °F	M
Maximum Start Position	100%	0 to 100%	M
Maximum Position @	90 °F	0 to 100 °F	M
Error Gain	25	10 to 99	M
Slope Gain	25	10 to 99	M

Set Unit Setpoints

```

SET UNIT SPs (1)
Unit Enable = OFF
Unit Mode   = COOL
Source     = Local

```

Unit Enable settings can be OFF and ON as determined from the Unit Enable set point. Unit Mode settings can be COOL, COOL w/Glycol, ICE, HEAT, or TEST as determined from the Unit Mode setpoint (TEST mode shall not be selectable from the 4x20 display/keypad although it may be displayed if already set).

Source settings can be LOCAL, SWITCHES, or NETWORK as determined from the Mode Source setpoint.

```

SET UNIT SPs (2)
Available Modes
    = COOL/HEAT
Select with unit off

```

Available Modes settings can be COOL, COOL/Glycol, COOL ICE w/Glycol., COOL/HEAT, HEAT or TEST, as determined from the Available Modes setpoint. This setpoint requires the unit to be turned off before changing.

```

SET UNIT SPs (3)
Cool LWT = XX.X°F
Ice  LWT = XX.X°F
Heat LWT = XXX.X°F

```

The Cool, Ice, and Heat setpoints are only displayed if the corresponding mode is available as specified by the Available Modes setpoint.

```

SET UNIT SPs (4)
Leaving Water Temp.
StartDelta= XX.X°F
StopDelta = X.X°F

```

StartDelta is the number of degrees above setpoint (below setpoint for Templifiers) for unit to start. StopDelta is the number of degrees below setpoint (above setpoint for Templifiers) for unit to stop.

```
SET UNIT SPs (5)
Reset Type =4-20mA
MaxResetDT =XX.X°F
StrtResetDT=XX.X°F
```

Reset Type settings can be NONE, RETURN (return chilled water), or 4-20 (external input) as determined by the LWT Reset Type setpoint.

```
SET UNIT SPs (6)
Soft Load = OFF
InitialSLamp=XXX%
SoftLoadRamp=Xxmin
```

Soft Load settings can be OFF or ON as determined from the Soft Load setpoint. InitialSLamp is the percent of full load amps that the unit starts to ramp up. SoftLoadRamp is number of minutes (1 to 60) to load from the initial percent amps to 100 percent amps.

```
SET UNIT SPs (7)
Max/Min LWT Rates
Max = X.X°F/min
Min = X.X°F/min
```

These setpoints determine the maximum and minimum allowable rate of chilled water temperature change. They may take precedence over loading rates based on the SoftLoad ramp.

```
SET UNIT SPs (8)
EvapRecTmr =X.Xmin
EvapPump = #1 ONLY
CondPump = #2 PRIM
```

Evap and Cond Pump settings can be #1 ONLY, #2 ONLY, #1 PRIM (Primary), #2 PRIM or AUTO as determined from the Evap Pump or Cond Pump setpoints.

```
SET UNIT SPs (9)
Templifier
SrcNoStart =XX°F
Delta Reset=XX°F
```

These settings only apply to Templifier units. SrcNoStart sets the entering source water temperature below which the unit is prevented from starting. Delta Reset sets the source water temperature below which the hot water temperature is reset down as the source water temperature drops.

```
SET UNIT SPs (10)
VFD = Yes
Min Speed = XXX%
Spd/Lift=XXX%/XX°F
```

VFD settings can be NO or YES as determined by the VFD set point.

```

SET UNIT SPs (11)
Max Wtr Flow Rates
Evap WF = XXXXX GPM
Cond WF = XXXXX GPM

```

These setting are used when field supplied and installed flow meters are present to calibrate them.

```

SET UNIT SPs (12)
CLOCK
dd/mmm/yyyy
hh:mm:ss

```

```

SET UNIT SPs (13)
Units = °F/psi
Lang = ENGLISH

```

```

SET UNIT SPs (14)
Protocol =
Ident Number +
Baud Rate =

```

```

SET UNIT SPs (15)
Ex Valve Gain = 100
Offset(Slope) = 271
Prs Ctrl Dout = 10°F

```

Screen 15 controls the electronic expansion valve (EXV) and is set as close as possible to known job operating conditions. **Ex Valve Gain** values less than the default of 100 pivot the curve slope to the right (downward). Values greater than the default of 100 pivot the slope upward, resulting in a greater valve opening for a given condenser delta-T, with the effect increasing as the delta-T increases. Very little effect is seen at low delta-Ts (low loads) See Figure 29.

Offset (Slope) values above 271 move the curve upward parallel, increasing the valve opening the same amount regardless of the condenser delta-T. Values less than 271 have the opposite effect.

Prs Ctrl Dout (pressure control dropout) setting (see Figure 30) determines the leaving chilled water temperature at which the EXV transitions from pressure control based on chilled water temperature to program control based on condenser delta-T (trimed by lift). This pressure control mode provides a controlled pulldown of the chilled water temperature on system startup.

Figure 29, EXV Control Parameters (Program Control Mode)

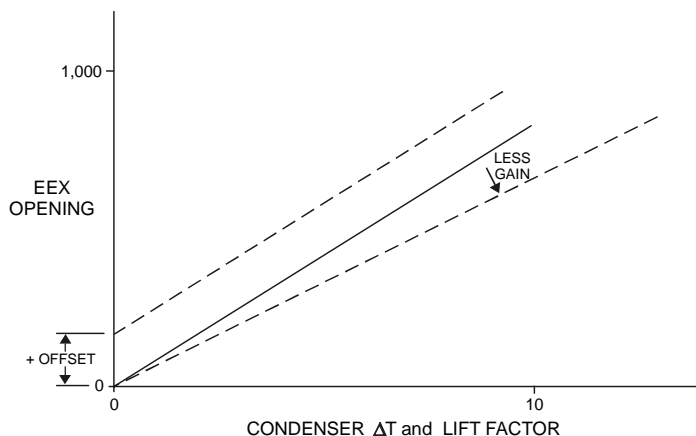
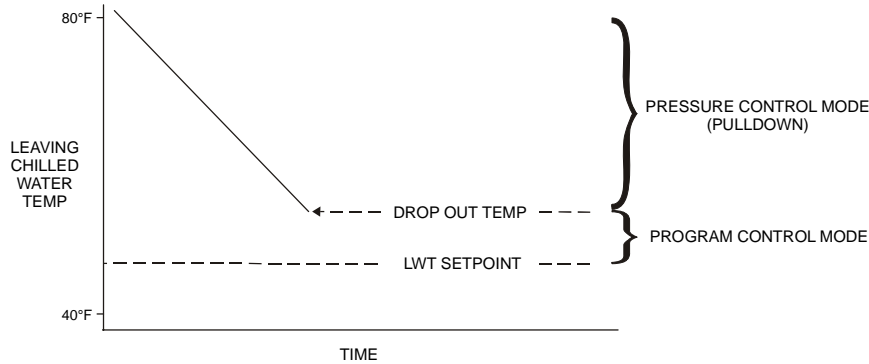

Figure 30, Pressure Control Dropout



Set Compressor Setpoints

```
SET COMP#N SPs (1)
Demand Limit = OFF
Minimum Amps =XXX%
Maximum Amps =XXX%
```

Demand Limit settings can be OFF or ON as determined from the Demand Limit setpoint.

```
SET COMP#N SPs (2)
StageMode = NORMAL
StageSequence# =XX
Max Compr s ON = XX
```

StageMode settings can be NORMAL, HI EFF, PUMP, and STANDBY as determined by the Stage Mode setpoint.

NORMAL has the auto-balance sequence that starts compressors with least starts and stops compressors with most hours, in sequence, providing all compressors have the same sequence number. If they have different sequence numbers, say 1, 2, 3, 4, they will always start in that sequence. That is, sequence number will take precedence over auto-balance sequencing.

HI EFF is used with multiple chillers and runs one compressor per chiller when ever possible.

PUMP starts all compressors on the same chiller first, starting with the chiller with the compressor with the least starts (or by sequence number if they are different).

STANDBY is used in multi-compressor systems and reserves a compressor to come on only if there is a failure of another compressor in the system and the standby compressor capacity is required to maintain chilled water temperature.

StageSequence is set for each compressor:

In NORMAL or STANDBY Mode, all compressors can have the same number or a number from 1 up to the total number of compressors. Sequence number has priority over other considerations. If four compressors in a system are given the sequence numbers 1 through 4, they will always start in that order. With the same number they will auto-sequence.

In HI EFF or PUMP, all compressors must have the same sequence number.

Max Compr s ON limits the number of compressors allowed to run in multi-compressor systems. It provides a "floating standby" compressor. All compressor controllers must have the same setting for this setpoint.

```

SET COMP#N SPs (3)
StageDeltaT= X.X°F
Stop-Start = xx min.
Start-Start =xx min.

```

```

SET COMP#N SPs (4)
Full Load = XXX sec

```

```

SET COMP#N SPs (5)
OilNoStrtDiff=XX°F
Abs Capacity=XXXXT
HotGasBypass = XX%

```

```

SET COMP#N SPs (6)
UnloadTimer=XXXsec
PrelubeTmr=xxxsec
PostlubeTmr=XXXsec

```

Before Entering Edit Mode	After Entering Edit Mode
SET COMP#N (7)	SET COMP#N (7)
VaneMode=AUTO	VaneMode=AUTO <AUTO
Vanes=UNKNOWN	Vanes=UNKNOWN <LOAD
%RLA = XXX%	%RLA = XXX% <UNLD

VaneMode settings can be AUTO or MAN (Manual) as determined from the Vane Mode setpoint. Vanes position is indicated as CLOSED or UNKNOWN as determined from the Vanes Closed switch digital input. When Edit mode is selected on this screen, the <AUTO/<LOAD/<UNLD prompts will appear. Holding the “LOAD” key will then continuously load the compressor and holding the “UNLD“ key will unload it. After releasing either key the compressor will “hold” and the Vane Mode setpoint will be set to Manual. Pressing the AUTO” key will set the Vane Mode back to Auto. After leaving edit mode the <AUTO/<LOAD/<UNLD prompts will be hidden.

The following VFD screen will only be shown if the VFD set point = YES.

Before Entering Edit Mode	After Entering Edit Mode
SET COMP#N (8)	SET COMP#N (8)
VFD Mode=AUTO	VFD Mode=AUTO <AUTO
VFD = XXX%	VFD = XXX% <LOAD
%RLA = XXX%	%RLA = XXX% <UNLD

VFD Mode settings can be AUTO or MAN (Manual) as determined from the VFD Mode setpoint. VFD speed is shown as 0 to 100%. When Edit mode is selected on this screen, the <AUTO/<LOAD/<UNLD prompts will appear. Holding the “LOAD” key will then continuously speed up the VFD and holding the “UNLD” key will slow it down. After releasing either key the VFD will stay at the current speed and the VFD Mode setpoint will be set to Manual. Pressing the “AUTO” key will set the VFD Mode back to Auto. After leaving edit mode the <AUTO/<LOAD/<UNLD prompts will be hidden.

Staging Parameters

Full Load Determination

Each compressor determines if it is at its maximum capacity (or maximum allowed capacity) and, if so, set its Full Load flag. The flag shall be set (full load) when one or more of the following conditions are met.

- The compressor is at its physical limit of capacity which means:

For VFD Set Point = NO: The load output has been pulsed ON for a cumulative time equal to or greater than the Full Load set point. Any unload pulse shall reset the cumulative time to zero.

For VFD Set Point = YES: Load pulsing has exceeded the Full Load set point (as described above) AND the VFD speed = 100%

OR

The Vanes Open digital input is On AND the VFD speed = 100%.

- The %RLA is above or equals the Maximum Amp limit set point.
- The %RLA is above or equals the Demand Limit analog input value
- The %RLA is above or equals the Network Limit value
- The evaporator pressure is below the Low Evap Pressure-Inhibit set point.

When none of the above conditions are met, the Full Load flag shall be cleared.

Absolute Capacity

Each compressor shall estimate its absolute capacity from the present value of %RLA and the Absolute Capacity set point from the equation:

$$\text{Absolute Capacity} = (\%RLA \text{ Factor}) * (\text{Absolute Capacity set point})$$

Where the %RLA Factor is interpolated from the following table.

%RLA	0	50	75	100	150
%RLA Factor	0	0.35	0.75	1.00	1.50

Multiple Compressor Staging

- This section defines which compressor is the next one to start or stop. The next section defines when the start, or stop, is to occur.

Functions

- Can start/stop compressors according to an operator defined sequence.
- Can start compressors based on # of starts (run hours if starts are equal) and stop on run hours.

- The above two modes can be combined so that there are two or more groups where all compressors in the first group are started (based on number of starts/hours) before any in the second group, etc. Conversely, all compressors in a group are stopped (based on run hours) before any in the preceding group, etc.
- An “efficiency priority” mode can be selected for two or more chillers where one compressor is started on each chiller in the group before a second is started on any of them.
- A “pump priority” mode can be selected for one or more chillers where all compressors on a given chiller are started before going to the next chiller in the group.
- One or more compressors can be defined as “standby” where it is never used unless one of the normal compressors is unavailable.

Set Alarm Setpoints

```
SET ALARM LMTS (1)
LowEvPrHold=XXXpsi
LowEvPrUnld=XXXpsi
LowEvPrStop=XXXpsi
```

```
SET ALARM LMTS (2)
HighCondPr=XXXXpsi
HiDschT-Load=XXX°F
HiDschT-Stop=XXX°F
```

```
SET ALARM LMTS (3)
HiOilFeedTmp=XXX°F
LowOilDeltaT =XX°F
LowNetOilPr=XXXpsi
```

```
SET ALARM LMTS (4)
HighSSH-Start=XX°F
HighSSH-Run =XX°F
MtrCurrThrshld=XX%
```

```
SET ALARM LMTS (5)
Evap Freeze=XX.X°F
Cond Freeze=XX.X°F
```

Set Tower Setpoints

NOTE: A complete description of the setup for cooling towers is found on page 29.

```
SET TOWER SPs (1)
TowerControl = None
Tower Stages = x
StageUP/DN=XXX/XXX%
```

TowerControl settings can be None, Temp, or Lift. Stages is the number of fans controlled, 1 to 4.

Tower Control = Temp/None	Tower Control = Lift
SET TOWER SPs (2)	SET TOWER SPs (2)
Stage ON (Temp) °F	Stage ON (Lift) psi
#1 #2 #3 #4	#1 #2 #3 #4
XXX XXX XXX XXX	XXX XXX XXX XXX

Tower Control=Temp/None	Tower Control=Lift(psi)
SET TOWER SPs (3)	SET TOWER SPs (3)
StageDiff = XX.X °F	StageDiff = XX.X psi
Stage Up = XX min	Stage Up = XX min
StageDown = XX min	StageDown = XX min

SET TOWER SPs (4)
Valve/VFD Control=
ValveSP/VFDStage
Valve Type = NC

Valve/VFD Control settings are None, Valve Setpoint, Valve Stage, VFD Stage, or ValveSP/VFDStage. Valve Type settings are NC (normally closed to tower) or NO (normally open).

Tower Control = Temp/None	Tower Control = Lift
SET TOWER SPs (5)	SET TOWER SPs (5)
Valve SP = XXX °F	Valve SP = XXX psi
Valve DB = XX.X °F	Valve DB = XXX.X psi

SET TOWER SPs (6)
ValveStartPosition
Min = XXX% @XXX °F
Max = XXX% @XXX °F

SET TOWER SPs (7)
Valve Control Range
Min = XXX%
Max = XXX%

SET TOWER SPs (8)
PD Control Loop
Error Gain = XX
Slope Gain = XX

Alarms

When an alarm occurs, the alarm type, limit value (if any), date, and time are stored in the active alarm buffer corresponding to that alarm (viewed on the Active Alarm screen) and also in the alarm history buffer (viewed on the Alarm History screen). The active alarm buffers hold a record of the last occurrence of each alarm and whether or not it has been cleared. The alarm can be cleared by pressing the Edit key. A separate buffer is available for each alarm (High Cond Pressure, Evaporator Freeze Protect, etc.). The alarm history buffer holds a chronological account of the last 50 alarms of any type.

Security

Entering on the Unit Controller

Two four-digit passwords provide OPERATOR and MANAGER levels of access to changeable parameters. Either password can be entered using the SET PASSWORD screen which can be accessed either through the SET OTHER menu or by simply pressing the ENTER key while on one of the SET screens. The password can then be entered by

1. Press the ENTER key.
2. Move to each number space to be changed with the right or left button.
3. Enter the correct value by scrolling with the UP and DOWN arrow keys. The password is right justified on the controller screen. The operator password would look like 00100, the manager password would be 02001.
4. Press ENTER again to enter the password

Once the correct password has been entered, the previously selected screen will reappear. Once a password has been entered, it will remain valid for 15 minutes after the last key-press. Parameters and screens that require the MANAGER password will not be displayed unless the MANAGER password is active.

Entering on the OITS

When a password is required, the touch screen will automatically go to the screen keyboard. Numbers are left justified and the operator password would be 100 (appearing as *** in the window). See page 22 for further information.

Compressor Controller

A general description of the unit controller with its inputs and outputs is on page 8. This section will briefly describe the operation of the controller, define the screen hierarchy and how to navigate through it and also give a description of the screens.

Relevant compressor information and setpoint changes are available on the OITS and on the unit controller. There is little need to consult the compressor controller(s).

4x20 Display & Keypad

Layout

The 4-line by 20-character/line liquid crystal display and 6-key keypad are shown below.

Figure 31, Display (in MENU mode) and Keypad Layout

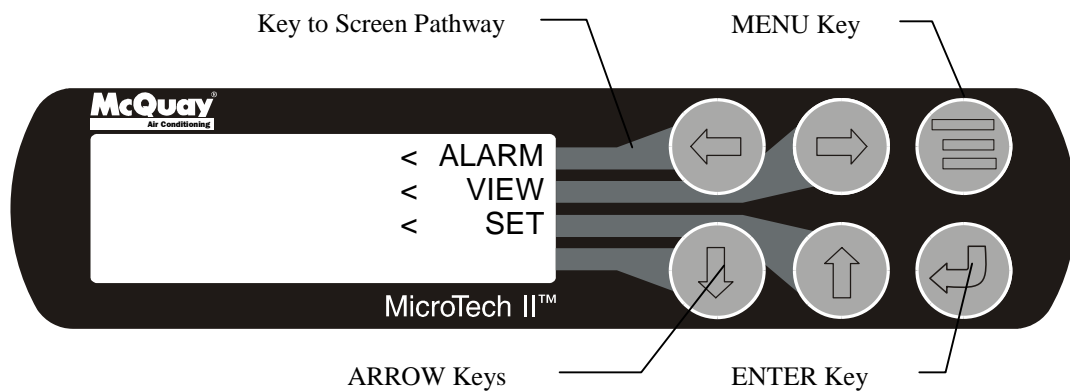

Note that each ARROW key has a pathway to a line in the display. Pressing an ARROW key will activate the associated line when in the MENU mode.

Getting Started

There are two basic procedures to learn in order to utilize the MicroTech II controller:

1. Navigating through the menu matrix to reach a desired menu screen and knowing where a particular screen is located.
2. Knowing what is contained in a menu screen and how to read that information or how to change a setpoint contained in the menu screen.

Navigating

The menus are arranged in a matrix of screens across a top horizontal row. Some of these top-level screens have sub-screens located under them.

There are two ways to navigate through the menu matrix to reach a desired menu screen.

One is to scroll through the matrix from one screen to another using the four ARROW keys.

The other way is to use shortcuts to work through the matrix hierarchy. From any menu screen, pressing the MENU key will take you to the top level of the hierarchy. The display will show ALARM, VIEW, and SET as shown in Figure 31. One of these groups of screens can then be selected by pressing the key connected to it via the pathway.

For example, selecting ALARM will go the next row of menus under ALARM (ALARM LOG or ACTIVE ALARM). Selecting VIEW will go the next level of screens under VIEW (VIEW UNIT STATUS or VIEW UNIT TEMP). Selecting SET will go to a series of screens for looking at and changing setpoints.

MENU Key

The MENU key is used to switch between the shortcut method (known as the MENU mode and as shown in Figure 31) and scrolling method (known as the SCROLL mode). The MENU mode is the shortcut to specific groups of menus used for checking ALARMS, for VIEWING information, or to SET setpoint values. The SCROLL mode allows the user to move about the matrix (from one menu to another, one at a time) by using the four ARROW keys.

Pressing the MENU key from any menu screen will automatically return you to the MENU mode.

Figure 32, Display in the Shortcut (SCROLL) Mode and Keypad Layout

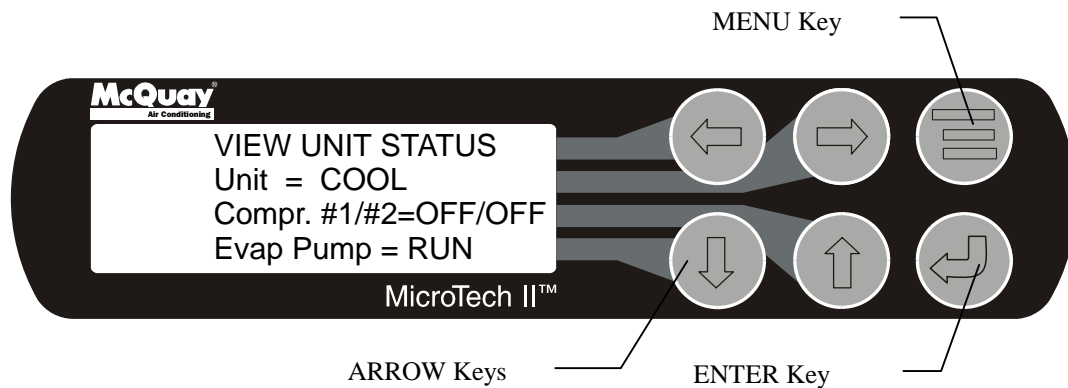

Menu Screens

Various menus are shown in the controller display. Each menu screen shows specific information; in some cases menus are used only to *view* the status of the unit, in some cases they are used for checking and clearing *alarms*, and in some case they are used to *set* setpoint values.

The menus are arranged in a matrix of screens across a top horizontal row. Most of these top-level screens have sub-screens located under them.

The ARROW keys on the controller are used to navigate through the menus. The keys are also used to change numerical setpoint values contained in certain menus.

Compressor Controller Setpoints

Set Compressor Setpoints

NOTE: In the following SET COMP screens, the #N field indicates which compressor (#1, #2, etc.) is being set and is not shown on single compressor units where screens are shown for compressor #1 only. Screen layout for compressor #2 for dual compressor units are identical to #1.

Table 24, Compressor Setpoints

Description	Default	Range	PW
Unit (Duplicates)			
Unit Enable	OFF	OFF, ON	O
Unit Mode	COOL	COOL, ICE, HEAT, TEST	O T
Cool LWT	44.0°F	35.0 to 80.0 °F	O
Ice LWT	25.0°F	15.0 to 35.0 °F	O
Heat LWT	135.0°F	100.0 to 150.0 °F	O
Startup Delta T	3.0°F	0.5 to 10.0 °F	O
Shutdown Delta T	3.0°F	0.0 to 3.0 °F	O
VFD			
Compressor VFD	No	No, Yes	T
VFD Minimum Speed	70%	70 to 100%	T
Speed @ 0 Lift	50%	0 to 100%	T
Lift @ 100% Speed	40 °F	30 to 60 °F	T
Motor Amps			
Demand Limit Enable	OFF	OFF, ON	O
Minimum Amps	40%	5 to 80%	T
Maximum Amps	100%	10 to 100%	T
Soft Load Enable	OFF	OFF, ON	M
Initial Soft Load Limit	40%	10 to 100%	M
Soft Load Ramp Time	5 min	1 to 60 min	M
Maximum LWT Rate	0.5 °F/min	0.1 to 5.0 °F/min	M
Minimum LWT Rate	0.1 °F/min	0.0 to 5.0 °F/min	M
Staging			
Comp Stage Mode	Normal	Normal, Efficiency, Pump, Standby	M
Comp Stage Sequence #	1	1,2, ... (# of Compressors)	M
Maximum Compressors ON	1	1-16	M
Stage Delta T	1.0	0.5-5.0	M
Full Load Timer	120 sec	0 to 999 sec	T
Nominal Capacity	Per Comp	0 to 9999	T
Timers			
Start-Start	40 min	15 to 60 min	M
Stop-Start	3 min	3 to 20 min	M
Oil			
Oil Feed Temperature	100 °F	90 to 190 °F	T
Oil No Start Diff (above Evap Temp)	40 °F	30 to 60 °F	T
Templifier			
Source No Start	70 °F	50 to 100 °F	T
Alarms			
Evaporator Freeze Protection	34.0 °F	-9.0 to 45.0 °F	T
Condenser Freeze Protection	34.0 °F	-9.0 to 45.0 °F	T
Low Evap Pressure-Stop	26 psi	10 to 45 psi	T
Low Evap Pressure-Inhibit	38 psi	20 to 45 psi	T
Low Evap Pressure-Unload	31 psi	20 to 45 psi	T
High Discharge Temperature-Stop	190 °F	120 to 240 °F	T
High Discharge Temperature-Load	170 °F	120 to 240 °F	T
High Condenser Pressure	140 psi	120 to 240 psi	T
Motor Current Threshold	10%	3 to 99%	T
High Oil Feed Temperature	140 °F	120 to 240 °F	T
Low Oil Delta Temperature	30 °F	20 to 80 °F	T
Low Net Oil Pressure	40 psi	30 to 60 psi	T
Surge Slope Limit	20 °F	1 to 99 Deg F/min	T
Surge Temp Limit	7 °F	2 to 25 °F	T
Service			
Vane Mode	AUTO	AUTO, MANUAL	T
VFD Mode	AUTO	AUTO, MANUAL	T
Hot Gas Bypass	30%	20 to 70%	T
Unload Timer	30 sec	10 to 240 sec	T
Postlube Timer	30 sec	10 to 240 sec	T

```
SET COMP#N SPs (1)
Demand Limit = OFF
Minimum Amps =XXX%
Maximum Amps =XXX%
```

Demand Limit settings can be OFF or ON as determined from the Demand Limit setpoint.

```
SET COMP#N SPs (2)
StageMode = NORMAL
StageSequence# =XX
Max Comprs ON = XX
```

StageMode settings can be NORMAL, HI EFF, PUMP, and STANDBY as determined by the Stage Mode setpoint. NORMAL is the auto balance sequence starting compressors with least starts and stopping with most hours, in sequence. HI EFF is used with multiple dual compressor chillers and runs one compressor per chiller when ever possible. PUMP starts all compressors on the same chiller first starting with the chiller with the compressor with the least starts. STANDBY is used in multi-compressor systems and reserves a compressor to come on only if there is a failure of another compressor in the system and the standby compressor capacity is required to maintain chilled water temperature.

StageSequence is set for each compressor:

In NORMAL or STANDBY Mode, all compressors can have the same number or a number from 1 up to the total number of compressors. Sequence number has priority over other considerations. If four compressors in a system are given the sequence numbers 1 through 4, they will always start in that order. With the same number they will auto-sequence.

In HI EFF or PUMP, all compressors must have the same sequence number.

Max Comprs ON limits the number of compressors allowed to run in multi-compressor systems. It provides a "floating standby" compressor. All compressor controllers must have the same setting for this setpoint.

```
SET COMP#N SPs (3)
StageDeltaT= X.X°F
Stop-Start = xx min.
Start-Start =xx min.
```

```
SET COMP#N SPs (4)
Full Load = XXX sec
```

```
SET COMP#N SPs (5)
OilNoStrtDiff=XX°F
Abs Capacity=XXXXT
HotGasBypass = XX%
```

SET COMP#N SPs (6) UnloadTimer=XXXsec PrelubeTmr=xxxsec PostlubeTmr=XXXsec

Before Entering Edit Mode	After Entering Edit Mode
SET COMP#N (7) VaneMode=AUTO Vanes=UNKNOWN %RLA = XXX%	SET COMP#N (7) VaneMode=AUTO <AUTO Vanes=UNKNOWN <LOAD %RLA = XXX% <UNLD

VaneMode settings can be AUTO or MAN (Manual) as determined from the Vane Mode setpoint. Vanes position is indicated as CLOSED or UNKNOWN as determined from the Vanes Closed switch digital input. When Edit mode is selected on this screen, the <AUTO/<LOAD/<UNLD prompts will appear. Holding the “LOAD” key will then continuously load the compressor and holding the “UNLD” key will unload it. After releasing either key the compressor will “hold” and the Vane Mode setpoint will be set to Manual. Pressing the “AUTO” key will set the Vane Mode back to Auto. After leaving edit mode the <AUTO/<LOAD/<UNLD prompts will be hidden.

The following VFD screen will only be shown if the VFD set point = YES.

Before Entering Edit Mode	After Entering Edit Mode
SET COMP#N (8) VFD Mode=AUTO VFD = XXX% %RLA = XXX%	SET COMP#N (8) VFD Mode=AUTO <AUTO VFD = XXX% <LOAD %RLA = XXX% <UNLD

VFD Mode settings can be AUTO or MAN (Manual) as determined from the VFD Mode setpoint. VFD speed is shown as 0 to 100%. When Edit mode is selected on this screen, the <AUTO/<LOAD/<UNLD prompts will appear. Holding the “LOAD” key will then continuously speed up the VFD and holding the “UNLD” key will slow it down. After releasing either key the VFD will stay at the current speed and the VFD Mode setpoint will be set to Manual. Pressing the “AUTO” key will set the VFD Mode back to Auto. After leaving edit mode the <AUTO/<LOAD/<UNLD prompts will be hidden.

Staging Parameters

Full Load Determination

Each compressor determines if it is at its maximum capacity (or maximum allowed capacity) and, if so, set its Full Load flag. The flag shall be set (full load) when one or more of the following conditions are met.

- The compressor is at its physical limit of capacity which means:

For VFD Set Point = NO: The load output has been pulsed ON for a cumulative time equal to or greater than the Full Load set point. Any unload pulse shall reset the cumulative time to zero. The cumulative time must be limited (to a value above the maximum allowed setting of the Full Load set point) so that no wrap occurs.

For VFD Set Point = YES: Load pulsing has exceeded the Full Load set point (as described above) AND the VFD speed = 100%

OR

The Vanes Open digital input is On AND the VFD speed = 100%.

- The %RLA is above or equals the Maximum Amp limit set point.
- The %RLA is above or equals the Demand Limit analog input value
- The %RLA is above or equals the Network Limit value
- The evaporator pressure is below the Low Evap Pressure-Inhibit set point.

When none of the above conditions are met, the Full Load flag shall be cleared.

Absolute Capacity

Each compressor shall estimate its absolute capacity from the present value of %RLA and the Absolute Capacity set point from the equation:

$$\text{Absolute Capacity} = (\% \text{RLA Factor}) * (\text{Absolute Capacity set point})$$

Where the %RLA Factor is interpolated from the following table.

%RLA	0	50	75	100	150
%RLA Factor	0	0.35	0.75	1.00	1.50

Multiple Compressor Staging

- This section defines which compressor is the next one to start or stop. The next section defines when the start, or stop, is to occur.

Functions

- Can start/stop compressors according to an operator defined sequence.
- Can start compressors based on # of starts (run hours if starts are equal) and stop on run hours.
- The above two modes can be combined so that there are two or more groups where all compressors in the first group are started (based on number of starts/hours) before any in the second group, etc. Conversely, all compressors in a group are stopped (based on run hours) before any in the preceding group, etc.
- An “efficiency priority” mode can be selected for two or more chillers where one compressor is started on each chiller in the group before a second is started on any of them.
- A “pump priority” mode can be selected for one or more chillers where all compressors on a given chiller are started before going to the next chiller in the group.
- One or more compressors can be defined as “standby” where it is never used unless one of the normal compressors is unavailable.

Optional Starter Screens

Figure 33, Optional Starter View Screen

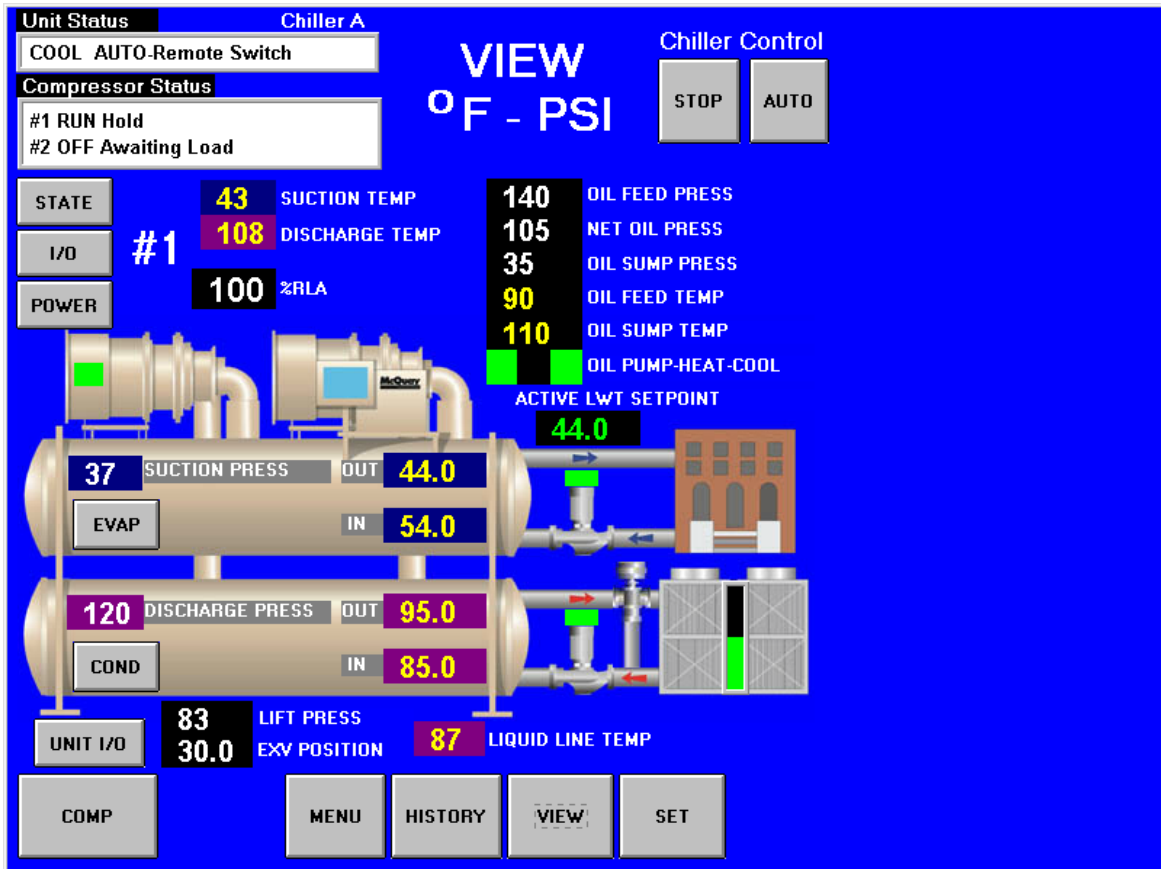

The ability to view the starter(s) electrical performance and to set starter setpoints on the operator interface screen is an optional extra available at the time of purchase. If the option is supplied on the unit, the “STARTER” button will be visible on the upper left side of the VIEW screen as shown above. Pressing the button will open the screen shown to the right.

Figure 34, Expanded Starter View Screen

The screen shown to the right will be superimposed on the right side of the VIEW screen shown in Figure 34 when the optional “Full Meter Display” is included with the unit.

If the “Full Meter Display” package is not ordered, only the Percent Unit RLA amps will appear on the Home screen. This screen will remain visible until another display button; such as STATE, I/O, etc, is selected.

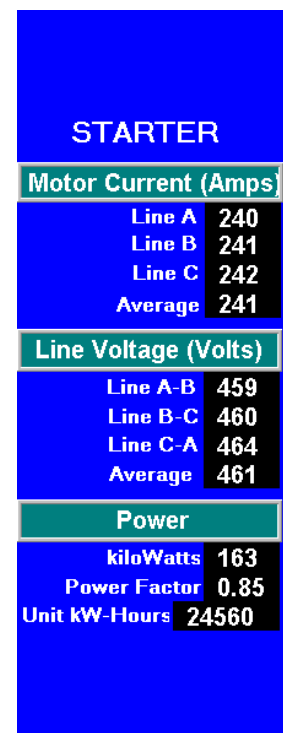

Low Voltage Starters, 200 – 600 Volts

This section contains information on low voltage, Wye-Delta and solid-state starters as manufactured by Benshaw Inc. for McQuay centrifugal Chillers. They are known collectively as “D3” starters. These low voltage starters have similar hardware and software (designated D3) and are grouped together in this manual. Model numbers are as follows:

D3WD11 to D3WD2K	Wye-Delta, Free Standing
D3WT11 to D3WT65	Wye-Delta, Factory (Terminal) Mounted
RVSS14 to RVSS4K	Solid State, Free Standing
RVST14 to RVST82	Solid State, Factory (Terminal) Mounted

General

These starters are completely automatic and require no operator intervention (other than clearing and resetting faults) to perform their function of providing a controlled connection of the compressor motor to the power supply.

The Wye-Delta and solid-state starters have many similar software characteristics and are discussed together in this section. However, some parameters and data are different. Where this occurs, separate tables and figures are provided.

Certain electrical operating data in the starter is transmitted to the chiller and can be viewed on the operator touch screen if the “Full Metering Option” has been ordered. See page 67.

Figure 35, Wye-Delta Starter

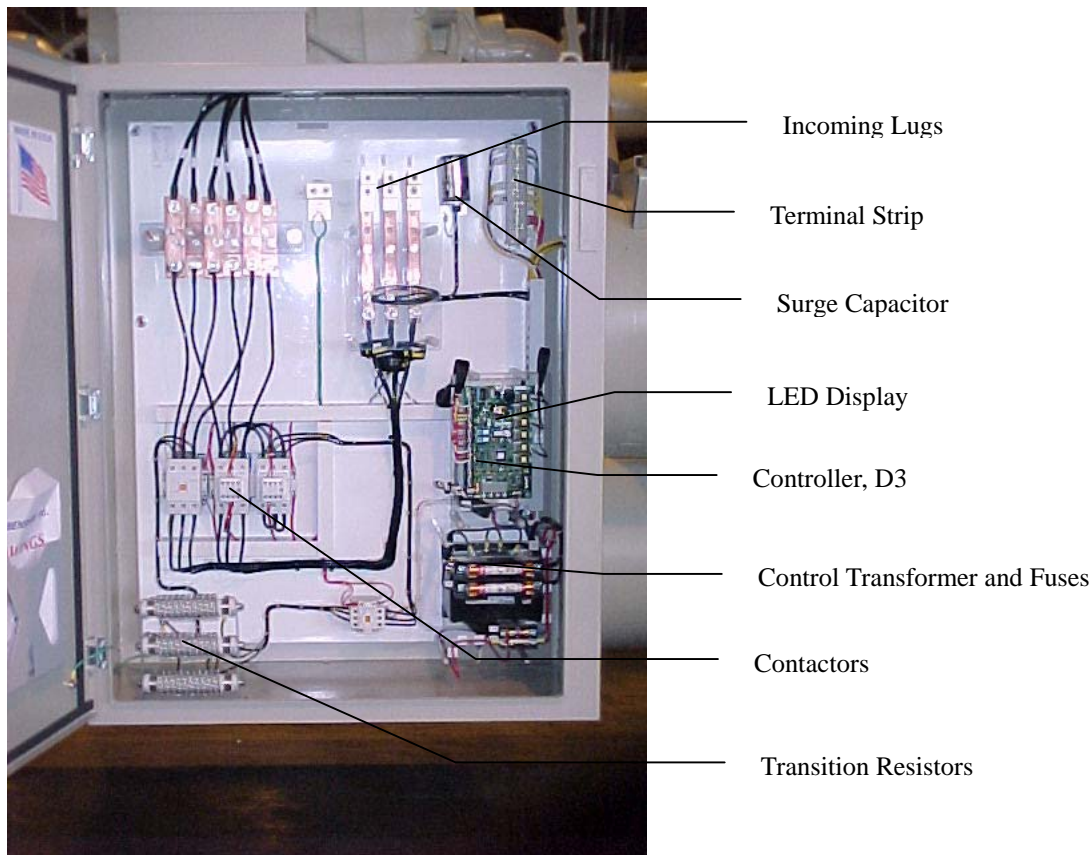
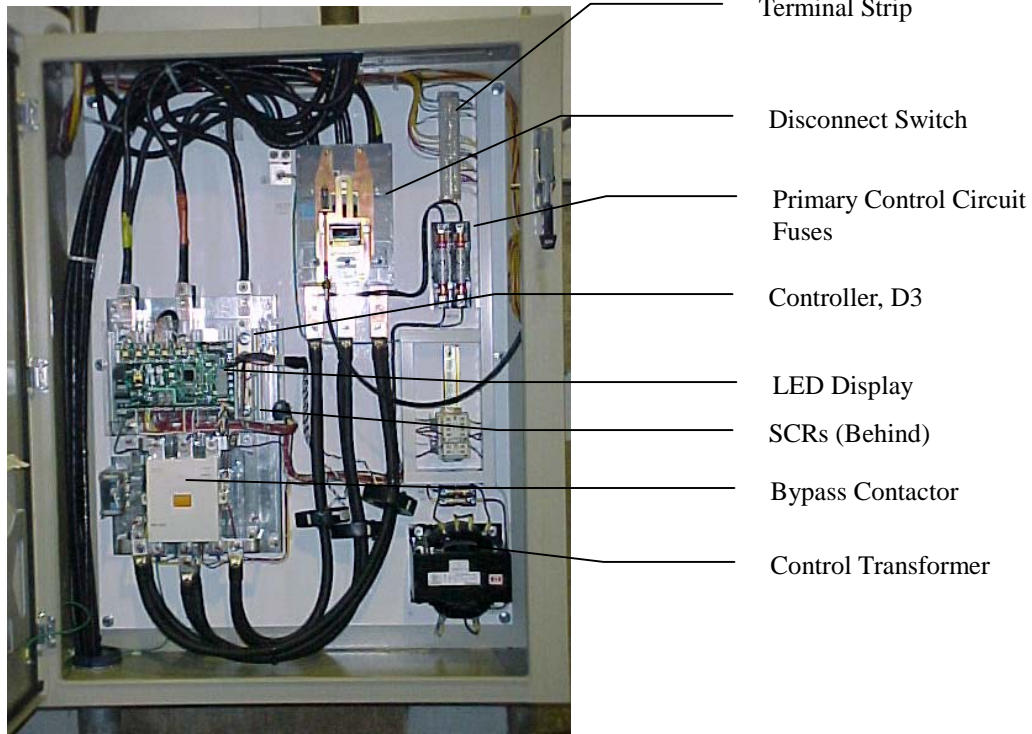

Figure 36, Solid State Starter, Wall Mounted



LED Display

There is an LED display and keypad within the starter enclosure as shown in Figure 35 and 39. It is used to set parameters (setpoints) and to view the operation of the motor/starter. Optionally, the following information can be passed on to the chiller operator interface touch screen:

- Standard-percent rated load amps on a bar chart and “Starter Fault” shown in the fault log when a fault occurs in the starter. The type of fault is not defined.
- Optional-above plus electrical operating data as shown on page 19.

Figure 37, Starter-mounted LED

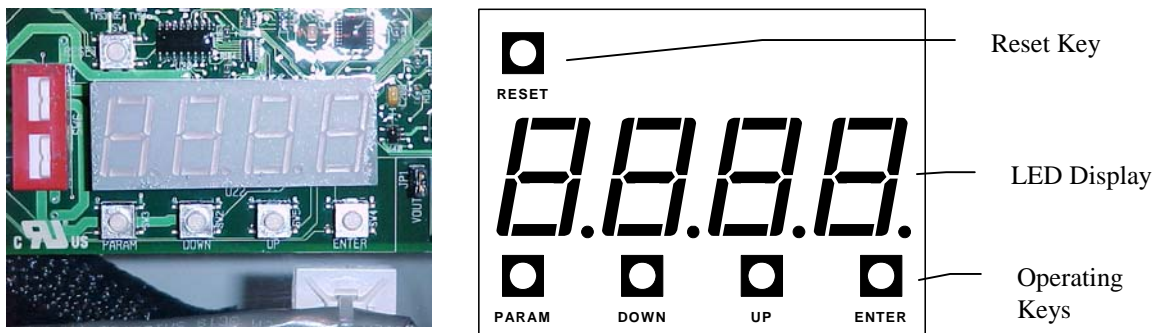

The LED display and keypad is used to:

1. Perform operations
2. View and set parameters (setpoints)
3. View operating messages
4. View faults and alarms

Operation

LED Display

- View parameters, messages and faults.
- Shows software revision on power up.

Programming

- Press **PARAM** to enter the menu and then **UP** or **DOWN** to reach the desired parameter.
- Press **ENTER** to show the present value of the parameter.
- Press **UP** or **DOWN** to change the parameter value.
- Press **ENTER** to store the new value or **PARAM** to abandon the change.

Quick Meters

- Press **DOWN** to display the motor thermal overload content.
- Press **UP** to display the incoming line phase order.
- Press **ENTER** to display the status meter.

View Parameters

Parameter view mode can be entered by:

1. At the default meter display, press the **PARAM** key to enter parameter mode. “P 1” will be displayed to indicate Parameter 1.
2. Use the **UP** and **DOWN** keys to scroll through the available parameters.
3. Pressing the **UP** key from “P 1” will advance to parameter “P 2”.
4. Pressing the **DOWN** key from “P 1” will wrap around to the highest parameter.
5. The value of the parameter can be viewed by pressing the **ENTER** key.
6. To view another parameter without changing/saving the parameter, press the **PARAM** key to return to the parameter number display.

To return to the default meter display either:

1. Press the **PARAM** key while in the parameter number display mode.
2. Wait 60 seconds and the display will return to the default meter display.

Set Parameters

The starter setpoint parameters are factory set and subsequently reviewed during commissioning by the McQuay startup technician. They should not be changed unless authorized by McQuay.

The programming procedure is explained above and the following table shows the range of values and defaults.



CAUTION

Improper setting of parameters can cause compressor damage or nuisance trips

Fault Log

- Press **PARAM**, Select P24 and press **ENTER**. The most recent fault will be displayed as “xFyy” where *x* will be 1 to indicate the most recent fault is being displayed and *yy* is the fault code.
- Press **DOWN** to view older faults. Up to 9 faults may be stored in the log.

Resetting a Fault

- First correct the cause of the fault. Then press **RESET** to reset from a fault.

Resetting Parameters

- Press and hold **PARAM** and **ENTER** on power up to reset parameters to default values.

Emergency Thermal Reset

- Press **RESET** and **DOWN** to perform an emergency thermal reset.

Table 25, Setpoints, Wye-Delta Starter

	Description	Values	Default
P1	Motor RLA	1 to 9999 Amps	1
P2	Motor Service Factor	1.00 to 1.99	1.08
P3	Motor Overload Class	OFF, 1 to 40	10
P4	Transition Time	1 to 30 seconds	10
P5	Default Meter Display	0 to 19	0
P6	Sequence Complete Delay Time	0.1 to 5.0 seconds	2.0
P7	Overcurrent Trip Level	OFF, 50 to 800 %RLA	OFF
P8	Overcurrent Trip Delay Time	0.1 to 90.0 seconds	2.0
P9	Rated RMS Voltage	208, 220, 230, 240, 380, 415, 440, 460, 480, 575 Volts	480
P10	Over Voltage Trip Level	OFF, 1 to 40 % rated Volts	10
P11	Under Voltage Trip Level	OFF, 1 to 40 % rated Volts	15
P12	Over/Under Voltage Delay Time	0.1 to 90.0 seconds	1.0
P13	Current Imbalance Trip Level	5 to 40 %	20
P14	Auto Fault Reset Time	OFF, 1 to 120 seconds	60
P15	CT Ratio	72, 96, 144, 288, 864, 2640, 2880, 5760, 8000	2640
P16	Control Source	TEr: = Terminal, NET: = Network	TEr
P17	Modbus Address	1 to 247	2
P18	Modbus Baud Rate	1.2, 2.4, 4.8, 9.6, 19.2 Kbps	19.2
P19	Modbus Timeout	OFF, 1 to 120 seconds	3
P20	Analog Output Function	0 to 11	1
P21	Analog Output Span	1 to 125 %	100
P22	Analog Output Offset	0 to 99 %	0
P23	Passcode (See Note)	0 to 9999	Disabled
P24	Fault Log	xFyy	–

Table 26, Setpoints, Solid State Starter

	Description	Values	Default
P1	Motor FLA	1 to 9999 Amps	10
P2	Motor RLA	1 to 9999 Amps	10
P3	Motor Service Factor	1.00 to 1.99	1.08
P4	Motor Overload Class	OFF, 1 to 40	10
P5	Initial Motor Current	50 to 400 %FLA	100
P6	Maximum Motor Current	100 to 800 %FLA	600
P7	Ramp Time	0 to 300 seconds	15
P8	UTS Time (Up To Speed)	1 to 900 seconds	30
P9	Stop Mode	CoS: Coast dcL: Voltage Decel	CoS
P10	Decel Begin Level	100 to 0 % Volts	40
P11	Decel End Level	50 to 0 % Volts	20
P12	Decel Time	1 to 180 seconds	15
P13	Default Meter Display	0 to 19	0
P14	Overcurrent Trip Level	OFF, 50 to 800 %RLA	OFF
P15	Overcurrent Trip Delay Time	0.1 to 90.0 seconds	2.0
P16	Rated RMS Voltage	208, 220, 230, 240, 380, 415, 440, 460, 480, 575 Volts	480
P17	Over Voltage Trip Level	OFF, 1 to 40 % rated Volts	10
P18	Under Voltage Trip Level	OFF, 1 to 40 % rated Volts	15
P19	Over/Under Voltage Delay Time	0.1 to 90.0 seconds	1.0

Continued next page.

	Description	Values	Default
P20	Current Imbalance Trip Level	5 to 40 %	35
P21	Controlled Fault Stop	OFF, On	OFF
P22	Auto Fault Reset Time	OFF, 1 to 120 seconds	60
P23	CT Ratio	72, 96, 144, 288, 864, 2640, 2880, 5760, 8000	2640
P24	Control Source	Ter: Terminal Net: Network	tEr
P25	Modbus Address	1 to 247	2
P26	Modbus Baud Rate	1.2, 2.4, 4.8, 9.6, 19.2 Kbps	19.2
P27	Modbus Timeout	OFF, 1 to 120 seconds	3
P28	Analog Output Function	0 to 11	1
P29	Analog Output Span	1 to 125 %	100
P30	Analog Output Offset	0 to 99 %	0
P31	Passcode (See Note)	0 to 9999	Disabled
P32	Fault Log	xFyy	–

NOTE: Passcode is a numerical password that can be entered in the field. The factory default is to disable the password requirement. It is recommended that a Passcode not be entered.

Messages

Setpoint P5 for Wye-Delta or P13 for solid state can be set to establish what message is shown on the LED. Selecting meter display “0” (which is the default) will display the active status message as shown in Table 27 or Table 28, except if there is a fault (requiring a message) or some other information has been requested.

Alternatively, parameter P5 or P13 can be set to select a message (1 to 19 as shown in Table 29).

Table 27, Status Messages, Wye-Delta Starter

<i>noL</i>	No Line	<i>L CP</i>	Control Power Lockout – A start is not allowed because the control power is too low.
<i>rdY</i>	Ready	<i>oxxx</i>	xxx = overload content. Press DOWN to toggle.
<i>Strt</i>	Running in wye mode.	<i>F xx</i>	xx = Alarm code. If the condition persists, a fault will occur.
<i>uLS</i>	Running in delta mode.	<i>F xx</i>	xx = Fault code. Press RESET to clear.
<i>F OL</i>	Overload Alarm – The motor overload level is between 90% and 100%.	<i>IOC</i>	Instantaneous Overcurrent – Press RESET to clear.
<i>F FL</i>	Overload Fault – The motor overload level has reached 100%.	<i>dFLE</i>	Default – Flashes when parameter defaults are loaded.
<i>L OL</i>	Overload Lockout – A start is not allowed until the motor overload level cools below 100%.		

Table 28, Status Messages, Solid State Starter

<i>noL</i>	No Line	<i>L CP</i>	Control Power Lockout – A start is not allowed because the control power is too low.
<i>rdY</i>	Ready	<i>oxxx</i>	xxx = overload content. Press DOWN to toggle.
<i>Acc</i>	Accelerating	<i>F xx</i>	xx = Alarm code. If the condition persists, a fault will occur.
<i>uLS</i>	Up to Speed	<i>F xx</i>	xx = Fault code. Press RESET to clear.
<i>rUn</i>	Run – Done with ramp but not yet Up to Speed.	<i>IOC</i>	Instantaneous Overcurrent – Press RESET to clear.
<i>dcL</i>	Decelerating	<i>dFLE</i>	Default – Flashes when parameter defaults are loaded.
<i>F OL</i>	Overload Alarm – The motor overload level is between 90% and 100%.		
<i>F FL</i>	Overload Fault – The motor overload level has reached 100%.		
<i>L OL</i>	Overload Lockout – A start is not allowed until the motor overload level cools below 100%.		

Table 29, Default Meter Display

0: Status Message	7: Ave L-L Voltage RMS	14: KVA
1: Ave RMS Current	8: L1-L2 Voltage RMS	15: KWh
2: L1 RMS Current	9: L2-L3 Voltage RMS	16: MWh
3: L2 RMS Current	10: L3-L1 Voltage RMS	17: Phase Rotation
4: L3 RMS Current	11: Overload %	18: Line Frequency
5: Current Imbalance %	12: Power Factor	19: Analog Input
6: Ground Fault Current	13: KW	

Miscellaneous Messages

Display Output for the Standard Keypad

The display will output different information depending on the operation of the starter.

Power Up

The software version will be displayed as a series of blinking digits once power has been applied to the D3 control. If the parameters were being reset on power up, “dFLt” will be flashed on the display for three seconds, then the software version will be displayed.

Stopped

When the starter is not in the run mode, the display will show the status condition of the starter, such as “rdY” (ready), “L OL” (Overload Lockout), “noL” (No Line).

Alarm Condition

When an alarm condition exists, the display alternates between displaying the selected meter and the alarm code. The alarm code is displayed as “A XX”, where XX is the alarm code.

- When a thermal overload alarm condition exists, “A OL” will be displayed.
- When a no line alarm condition exists, “noL” will be displayed.

When the starter is stopped, the selected meter is not displayed.

Lockout Condition

When a lockout condition exists, the display shows the lockout code. The lockout code is displayed as “L XX: where XX is the lockout code. Following are the defined lockout conditions and their codes:

- When a motor thermal overload lockout condition exists, “L OL” will be displayed.
- When a power stack thermal overload lockout condition exists, “L Ot” will be displayed.
- When a low control power lockout condition exists, “L CP” will be displayed.

When there are multiple lockout codes, each will be displayed at 2 second intervals.

Faulted Condition

When a fault condition exists, the display shows the fault code Fxx. The exceptions to this are as follows:

- When the fault is thermal overload trip, “F OL” will be displayed.
- When the fault is Instantaneous over current, IOC will be displayed.

Quick Meters

Although any meter may be viewed by changing the meter parameter, there are 3 “Quick Meters” that are always available with a single key press. When the starter is in the normal display mode, the display may be toggled between the information currently displayed and the following quick meters.

Status Meter

Toggle between the programmed meter display and the starter operational status display (rdY, run, utS, dcL, etc) by pressing the **ENTER** key.

Overload meter

Toggle between the programmed meter display and the overload content by pressing the **DOWN** key. The overload will be displayed as “oXXX” where XXX is the overload content. For example if the overload content is 76 percent, it will be displayed as “o 76”.

Phase Order Meter

Toggle between the programmed meter display and the phase order by pressing the **UP** key. The phase order will be displayed as “AbC” or “CbA”. The phase order must be AbC to operate.

Restoring Factory Parameter Settings

To restore ALL parameters to the factory default settings, press and hold the **PARAM** and **ENTER** pushbutton switch on power up. The display will blink “dFLt”. Parameters unique to the motor starter applications will need to be set again to appropriate values before motor operation

Faults and Alarms

Starter and/or power problems can result in a fault or an alarm that will usually shut down the compressor and record a “Starter Fault” in the touchscreen’s active fault menu. The starter LED can then be consulted to determine the specific problem based on the code shown in the following table.

Alarm Reset Type

Table 30, Fault/Alarm Codes, Wye-Delta Starter, Y = Yes, N = No

	Description	Auto Reset
00	No fault	-
02	Motor Thermal Overload Trip	N
10	Phase Rotation Error, not ABC	Y
12	Low Line Frequency	Y
13	High Line Frequency	Y
15	Input power not three phase	Y
21	Low Line L1-L2 Voltage	Y
22	Low Line L2-L3 Voltage	Y
23	Low Line L3-L1 Voltage	Y
24	High Line L1-L2 Voltage	Y
25	High Line L2-L3 Voltage	Y
26	High Line L3-L1 Voltage	Y
27	Phase Loss	Y
28	No Line Voltage	Y
30	I.O.C. (Instantaneous Overcurrent)	N
31	Overcurrent	N
37	Current Imbalance	Y
38	Ground Fault	N
39	No Current at Run	Y
40	Open Line or Motor Lead	N
41	Current While Stopped	N
48	2M Feedback Fault (on DIN#2, No Transition)	N
50	Control Power Low	Y
51	Current Sensor Offset Error	N
52	Burden Switch Error	N

	Description	Auto Reset
60	Thermistor Trip (on DIN#1, Input from Motor Thermistor)	N
71	Analog Input Trip (Not Used)	Y
82	Modbus Timeout (Communication Fault)	Y
94	CPU Error – Software Fault	N
95	CPU Error – Parameter Storage Fault	N
96	CPU Error – Illegal Instruction Trap	N
97	CPU Error – Software Watchdog Fault	N
98	CPU Error – Spurious Interrupt	N
99	CPU Error – Program Storage Fault	N

NOTE: If a fault occurs that has a Y in the “Auto Reset” column, and P14 (Auto Fault Reset Time) is set to some value other than OFF, then the fault will automatically be cleared after the time specified by P14.

Table 31, Faults/Alarms, Solid State Starter

	Description	Controlled Stop	Auto Reset
00	No fault	-	-
01	UTS (Up To Speed) Time Limit Expired	Y	Y
02	Motor Thermal Overload Trip	Y	N
10	Phase Rotation Error, not ABC	N	Y
12	Low Line Frequency	N	Y
13	High Line Frequency	N	Y
15	Input power not three phase	N	Y
21	Low Line L1-L2 Voltage	Y	Y
22	Low Line L2-L3 Voltage	Y	Y
23	Low Line L3-L1 Voltage	Y	Y
24	High Line L1-L2 Voltage	Y	Y
25	High Line L2-L3 Voltage	Y	Y
26	High Line L3-L1 Voltage	Y	Y
27	Phase Loss	N	Y
28	No Line Voltage	N	Y
30	I.O.C. (Instantaneous Overcurrent)	N	N
31	Overcurrent	Y	N
37	Current Imbalance	Y	Y
38	Ground Fault	Y	N
39	No Current at Run	N	Y
40	Shorted / Open SCR	N	N
41	Current While Stopped, Motor Failed To Stop	N	N
47	Stack Protection Fault (SCR at Operating Limit)	N	Y
48	Bypass Contactor Fault (on STOP input)	Y	N
50	Control Power Low	N	Y
51	Current Sensor Offset Error	-	N
52	Burden Switch Error	N	N
60	Thermistor Trip (on DIN#1, Motor Overheat Input)	N	N
61	Stack OT Switch Trip (on DIN#2)	N	N
71	Analog Input Trip (Not Used)	Y	Y
82	Modbus Timeout (Communication Fault)	Y	Y
95	CPU Error – Parameter Storage Fault	N	N
96	CPU Error – Illegal Instruction Trap	N	N
97	CPU Error – Software Watchdog Fault	N	N
98	CPU Error – Spurious Interrupt	N	N
99	CPU Error – Program Storage Fault	N	N

1. If a fault occurs that has a Y in the “Controlled Stop” column, and P21 (Controlled Fault Stop) is set to On, and P9 (Stop Mode) is set to dcL, then the starter will perform a voltage decel to stop. Otherwise it will coast to stop.
2. If a fault occurs that has a Y in the “Auto Reset” column, and P22 (Auto Fault Reset Time) is set to some value other than OFF, then the fault will automatically be cleared after the time specified by P22.
3. Manual reset is accomplished by pressing the reset button on the LED display. See Figure 37. A stack over temperature fault (number 61) requires pressing the reset button located on the stack first.

Alarm Definitions

The following is a list of all D3 alarm codes. The alarm codes correspond to associated fault codes. In general, an alarm indicates a condition that if continued, will result in the associated fault.

Table 32, Alarm Codes

Alarm Code	Description	Notes
A02	Motor Overload Alarm	This occurs when the motor thermal content reaches the 90%. The D3 will trip when it reaches 100%. The alarm will continue until the overload trip lockout is reset.
A10	Phase Rotation not ABC	This alarm exists while the D3 is stopped and line voltage is detected and phase sensitivity parameter is set to ABC. If a start is commanded, a Fault 10 will occur.
A11	Phase Rotation not CBA	This alarm exists while the D3 is stopped and line voltage is detected and phase sensitivity parameter is set to CBA. If a start is commanded, a Fault 11 will occur.
A12	Low Line Frequency	This alarm exists when the D3 has detected a line frequency below the user defined low line frequency level. The alarm will continue until either the line frequency changes to be in range or the fault delay timer has expired.
A13	High Line Frequency	This alarm exists when the D3 has detected a line frequency above the user defined high line frequency level. The alarm will continue until either the line frequency changes to a valid frequency or the fault delay timer has expired.
A14	Input power not single phase	This alarm exists while the D3 is stopped, set to single phase mode, and line voltage is detected. If a start is commanded, a Fault 14 will occur.
A15	Input power not three phase	This alarm exists while the D3 is stopped, set to a three-phase mode, and single-phase line voltage is detected. If a start is commanded, a Fault 15 will occur.
A21	Low Line L1-L2	This alarm exists while the D3 is stopped and low line voltage is detected. If a start is commanded, a Fault 21 may occur.
A22	Low Line L2-L3	This alarm exists while the D3 is stopped and low line voltage is detected. If a start is commanded, a Fault 22 may occur.
A23	Low Line L3-L1	This alarm exists while the D3 is stopped and low line voltage is detected. If a start is commanded, a Fault 23 may occur.
A24	High Line L1-L2	This alarm exists while the D3 is stopped and high line voltage is detected. If a start is commanded, a Fault 24 may occur.
A25	High Line L2-L3	This alarm exists while the D3 is stopped and high line voltage is detected. If a start is commanded, a Fault 25 may occur.
A26	High Line L3-L1	This alarm exists while the D3 is stopped and high line voltage is detected. If a start is commanded, a Fault 26 may occur.

Continued next page.

Alarm Code	Description	Notes
A27	Phase Loss	This alarm exists while the D3 is running and a phase loss condition is detected, but the delay for the fault has not yet expired. When the delay expires, a Fault 27 will occur.
A28	No Line	This alarm exists while the D3 needs to be synced or is trying to sync to the line and no line is detected.
A31	Overcurrent	This alarm exists while the D3 is running and the average current is above the defined threshold, but the delay for the fault has not yet expired. When the delay expires, a Fault 31 will occur.
A34	Undercurrent	This alarm exists while the D3 is running and the average current is below the defined threshold, but the delay for the fault has not yet expired. When the delay expires, a Fault 34 will occur.
A35	Reserved	
A36	Reserved	
A37	Current Imbalance	This alarm exists while the D3 is running and a current imbalance above the defined threshold is detected, but the delay for the fault has not yet expired. When the delay expires, a Fault 37 will occur.
A38	Ground Fault	This alarm exists while the D3 is running and a ground current above the defined threshold is detected, but the delay for the fault has not yet expired. When the delay expires, a Fault 38 will occur.
A47	Stack Overload Alarm	This occurs when the stack thermal rises above 105%.
A53	Reserved	
A71	Analog Input #1 Trip	This alarm will exist if analog input #1 exceeds the defined threshold, but the delay for the fault has not yet expired. When the delay expires, a Fault 71 will occur.

Analog Output Function (P28)

The starter board has a designated terminal connection that will transmit one datum from the following table via a 0-10VAC signal. The datum point is selected in parameter P28.

0: OFF (no output)	6: KW (0 – 100KW)
1: Ave Current (0 – 200% RLA)	7: KW (0 – 1MW)
2: Ave Current (0 – 800% RLA)	8: KW (0 – 10MW)
3: Ave Voltage (0 – 750VAC)	9: Analog Input
4: Thermal Overload%	10:Reserved
5: KW (0 - 10KW)	11: Calibrate (full 100% output)

Troubleshooting

Table 33, Motor does not start, no output to motor

Condition	Cause	Solution
Display Blank, CPU Heartbeat LED on D3 board not blinking.	Control voltage absent.	Check for proper control voltage input. Verify fuses and wiring.
	D3 control board problem.	Consult factory.
Fault Displayed.	Fault Occurred.	See fault code troubleshooting table for more details.
Start command given but nothing happens.	Start/Stop control input problems.	Verify that the start/stop wiring and start input voltage levels are correct.
	Control Source parameters (P4-5) not set correctly.	Verify that the parameters are set correctly.

Continued on Next page.

Condition	Cause	Solution
NOL or No Line is displayed and a start command is given, it will fault in F28.	No line voltage has been detected	Check input supply for inline contactor, open disconnects, open fuses, open circuit breakers, or disconnected wiring.
		See fault code troubleshooting table for more details.

Table 34, During starting, motor rotates but does not reach full speed

Condition	Cause	Solution
Fault Displayed.	Fault Occurred.	See fault code troubleshooting table for more details.
Display shows Accel or Run.	Motor loading too high and/or current not dropping below 175% FLA indicating that the motor has not come up to speed.	Reduce load on motor during starting.
	Abnormally low line voltage.	Fix cause of low line voltage.
Motor Hums before turning	Initial current too low	Increase initial current

Table 35, Motor stops unexpectedly while running

Condition	Cause	Solution
Fault Displayed.	Fault Occurred.	See fault code troubleshooting table for more details.
Display Blank, Heartbeat LED on D3 board not blinking.	Control voltage absent.	Check for proper control voltage input. Verify wiring and fuses.
	D3 control board problem.	Consult McQuayService.

Table 36, Metering incorrect

Condition	Cause	Solution
Motor Current or Voltage meters fluctuating with steady load.	Loose connections.	Shut off all power and check all connections.
	Load actually not steady.	Verify that the load is actually steady and that there are not mechanical issues.
	Other equipment on same power feed causing power fluctuations and/or distortion.	Fix cause of power fluctuations and/or distortion.

Table 37, Other Situations

Condition	Cause	Solution
Motor Rotates in Wrong Direction	Phasing incorrect	If input phasing correct, exchange any two output wires.
		If input phasing incorrect, exchange any two input wires.
Erratic Operation	Loose connections	Shut off all power and check all connections.

Continued on the next page.

Condition	Cause	Solution
Motor Overheats	Motor overloaded	Reduce motor load.
	Too many starts per hour	Increase chiller LWT setpoint deadband.
	High ambient temperature	Reduce ambient temperature or provide for better cooling.
	Acceleration time too long	Reduce starting load.
	Motor cooling obstructed/damaged	Remove cooling air obstructions. Check motor cooling fan.
Starter cooling fans do not operate (When Present)	Fan power supply lost	Verify fan power supply, check fuses.
	Fan wiring problem	Check fan wiring.
	Fan failure	Replace fan
Remote Keypad does not operate correctly.	Keypad cable not plugged in properly or cable damaged.	Verify that the remote keypad cable has not been damaged and that it is properly seated at both the keypad and the D3 Control board.
	Display interface board (when present) not firmly plugged in.	Verify that the display interface board (if present) is firmly attached to D3 control card.
	Remote display damaged.	Replace remote display.

Table 38, Fault Code Troubleshooting Table

The following is a list of possible faults that can be generated by the D3 starter control.

Fault Code	Description	Detailed Description of Fault / Possible Solutions
F01	UTS (Up To Speed) Time Limit Expired	Motor did not achieve full speed before the UTS timer (QST 09, P9) expired.
		Check motor for jammed or overloaded condition.
		Evaluate UTS timer setting and, if acceptable, increase UTS timer setting (QST 09, P9).
F02 (F OL)	Motor Thermal Overload Trip	The D3 motor thermal overload protection has tripped.
		Check motor for mechanical failure, jammed, or overloaded condition.
		Verify that there is not an input line power quality problem or excessive line distortion present.
F10	Phase Rotation Error, not ABC	Verify correct phase rotation of input power. Correct wiring if necessary.
F11	Phase Rotation Error, not CBA	Verify correct phase rotation of input power. Correct wiring if necessary.
F12	Low Line Frequency	Line frequency below 23 Hz was detected.
		Verify input line frequency.
		If operating on a generator, check generator speed governor for malfunctions.
		Check input supply for open fuses or open connections
		Line power quality problem / excessive line distortion.

Continued on the next page.

Fault Code	Description	Detailed Description of Fault / Possible Solutions
F13	High Line Frequency	Line frequency above 72 Hz was detected.
		Verify input line frequency.
		If operating on a generator, check generator speed governor for malfunctions.
		Line power quality problem / excessive line distortion.
F14	Input power not single phase	Verify that single-phase power is connected to the L1 and L2 inputs. Correct wiring if necessary.
F15	Input power not three phase	Single-phase power has been detected when the starter is expecting three-phase power.
		Verify that input power is three phase. Correct wiring if necessary.
F21	Low Line L1-L2	Low voltage below the Undervoltage Trip Level parameter setting (PFN 08, P31) was detected for longer than the Over/Under Voltage Trip delay time (PFN 09, P32).
F22	Low Line L2-L3	Verify that the actual input voltage level is correct.
F23	Low Line L3-L1	Verify that the Rated Voltage parameter (FUN 05, P66) is set correctly.
		Check input supply for open fuses or open connections.
		On medium voltage systems, verify wiring of the voltage measurement circuit.
F24	High Line L1-L2	High voltage above the Over voltage Trip Level parameter setting (PFN 07, P30) was detected for longer than the Over/Under Voltage Trip delay time (PFN 09, P32).
F25	High Line L2-L3	Verify that the actual input voltage level is correct.
F26	High Line L3-L1	Verify that the Rated Voltage parameter (FUN 05, P66) is set correctly.
		Line power quality problems/ excessive line distortions.
F27	Phase Loss	The D3 control has detected the loss of one or more input or output phases when the starter was running. Can also be caused by line power dropouts.
		Check input supply for open fuses.
		Check power supply wiring for open or intermittent connections.
		Check motor wiring for open or intermittent connections.
		On medium voltage systems, verify wiring of the voltage feedback measurement circuit.
F28	No Line	No input voltage was detected for longer than the Inline Configuration time delay parameter setting (I/O 15, P53) when a start command was given to the starter.
		Check input supply for open disconnects, open fuses, open circuit breakers, or disconnected wiring.
		On medium voltage systems, verify wiring of the voltage feedback measurement circuit.
F30	I.O.C. (Instantaneous Overcurrent Current)	During operation, the D3 controller detected a very high level of current in one or more phases.
		Check motor wiring for short circuits or ground faults.
		Check motor for short circuits or ground faults.
		Check if power factor or surge capacitors are installed on the motor side of the starter.

Fault Code	Description	Detailed Description of Fault / Possible Solutions
F31	Overcurrent	Motor current exceeded the Over Current Trip Level setting (PFN 01, P24) for longer than the Over Current Trip Delay Time setting (PFN 02, P25).
		Check motor for a jammed or an overload condition.
F34	Undercurrent	Motor current dropped under the Under Current Trip Level setting (PFN 03, P26) for longer than the Under Current Trip Delay time setting (PFN 04, P27).
		Check system for cause of under current condition.
F37	Current Imbalance	A current imbalance larger than the Current Imbalance Trip Level parameter setting (PFN 05, P28) was present for longer than ten (10) seconds.
		Check motor wiring for cause of imbalance. (Verify dual voltage and 6 lead motors for correct wiring configuration).
		Check for large input voltage imbalances that can result in large current imbalances.
F38	Ground Fault	Ground current above the Ground Fault Trip level setting (PFN 06, P29) has been detected for longer than 3 seconds.
		Check motor wiring for ground faults.
		Verify that the CTs are installed with all the White dots towards the input line.
F39	No Current at Run	Motor current went below 10% of FLA while the starter was running.
		Check if load is still connected to starter
F40	Shorted / Open SCR	A shorted or open SCR condition has been detected.
F41	Current at Stop	Motor current was detected while the starter was not running.
F47	Stack Protection Fault (stack thermal overload)	The D3 electronic power stack OL protection has detected an overload condition.
F48	Bypass /2M Contactor Fault	A digital input has been programmed as a Bypass/2M Contactor Feedback input and an incorrect bypass feedback has been detected for longer than the Bypass Confirm time parameter setting (I/O 16, P54).
		Verify that the bypass contactor(s) are actually not damaged or faulty.
F50	Control Power Low	Low control power (below 90V) has been detected while running, by the D3 controller.
		Verify that the control power input level is correct especially during starting when there may be significant line voltage drop.
		Check control power transformer tap setting (if available).
		Check control power transformer fuses (if present).
		Check wiring between control power source and starter.
F51	Current Sensor Offset Error	Indicates that the D3 control board self-diagnostics have detected a problem with one or more of the current sensor inputs.
		Consult factory if fault persists.
F52	Burden Switch Error	The burden switch settings were changed when starter was running. Only change burden switches when starter is not running.
F60	External Fault on DI#1 Input	DI#1 has been programmed as a fault type digital input and the input indicates a fault condition is present.
F61	External Fault on DI#2 Input	DI#2 has been programmed as a fault type digital input and input indicates a fault condition is present.

Fault Code	Description	Detailed Description of Fault / Possible Solutions
F62	External Fault on DI#3 input	DI#3 input has been programmed as a fault type digital input and input indicates a fault condition is present.
F71	Analog Input Level Fault Trip.	Based on the Analog Input parameter settings, the analog input level has either exceeded or dropped below the Analog Input Trip Level setting (I/O 08, P46) for longer than the Analog Input Trip Delay time (I/O 09, P47).
F81	SPI Communication Fault	Indicates that communication has been lost with a remote device such as a remote keypad. (This fault will normally occur if the remote keypad is disconnected while the D3 control board is powered up. Only connect and disconnect a remote keypad when the control power is off.)
		Verify that the remote keypad cable has not been damaged and that its connectors are firmly seated at both the keypad and the D3 Control board.
		Route keypad cables away from high power and/or high noise areas to reduce possible electrical noise pickup.
F82	Modbus Timeout Fault	Indicates that the starter has lost serial communications. Fault occurs when the starter has not received a valid serial communications within the Communication Timeout parameter (FUN 12, P59) defined time.
		Examine remote system for cause of communication loss.
F94	CPU Error – SW fault	Typically occurs when attempting to run a version of control software that is incompatible with the D3 control board hardware being used. Verify that the software is a correct version for the D3 control board being used. Consult factory for more details.
		Fault can also occur if the D3 control has detected an internal software problem. Consult McQuayService.
F95	CPU Error – Parameter EEPROM Checksum Fault	The non-volatile user parameter values have been found to be corrupted. Typically occurs when the D3 control is re-flashed with new software.
		If fault persists after performing a Factory Parameter reset, consult McQuayService.
F96	CPU Error	The D3 control has detected an internal CPU problem. Consult McQuayService.
F97	CPU Error – SW Watchdog Fault	The D3 control has detected an internal software problem. Consult McQuayService.
F98	CPU Error	The D3 control has detected an internal CPU problem. Consult McQuayService.
F99	CPU Error – Program EPROM Checksum Fault	The non-volatile program memory has been corrupted.

Preventive Maintenance

During Commissioning

- Torque all power connections during commissioning, including pre-wired equipment.
- Check all control wiring for loose connections.

After First Month of Operation

- Re-torque all power connections, including pre-wired equipment annually.
- Clean accumulated dust with clean compressed air.
- Inspect cooling fans every three months.
- Clean or replace air vent filters every three months.

Medium/High Voltage Starters, 2300V – 7.2KV

This section contains information on medium voltage, across-the-line and solid state starters as manufactured by Benshaw Inc. for McQuay centrifugal Chillers. Medium voltage starters have similar software (Micro II) and are grouped together in this manual. Model numbers are as follows:

MVSS36 to MVSS30	Solid State, 2300V, Free Standing
MVSS50 to MVSS21	Solid State, 3300V, Free Standing
MVSS40 to MVSS20	Solid State, 4160V, Free Standing
HVSS42 to HVSS05	Solid State, 5.1KV to 7.2KV, Free Standing
MVAT12 to MVAT36	Across-the-Line, 2300V, Free Standing
MVAT16 to MVAT25	Across-the-Line, 3300V, Free Standing
MVAT13 to MVAT26	Across-the-Line, 4160V, Free Standing
HVAT27	Across-the-Line, 6600V, Free Standing

Figure 38, LED Display/Keypad

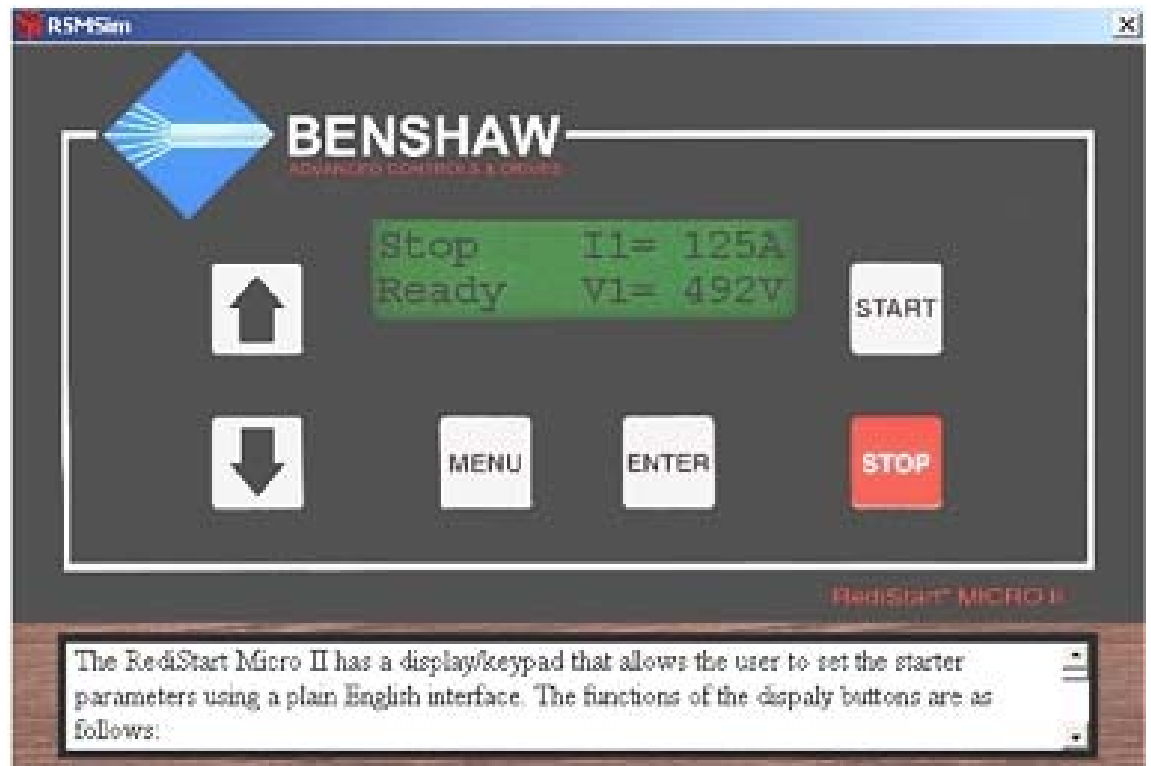

View Parameters

Follow these steps to access a specific parameter in the Micro II controller menu structure,.

- Press the Menu button to enter the menu system.
- Press the Up or Down buttons to get the desired menu on the display.
- Press the Enter button to go into the menu.
- Press the Up or Down button to get to the desired sub-menu, if necessary.
- Press the Enter button to go into the sub-menu, if necessary.
- Press the Up or Down arrow buttons until the parameter is displayed.

Set Parameters

The starter's setpoint parameters are factory-set and subsequently reviewed during commissioning by the McQuay startup technician. They should not be changed unless authorized by McQuay.

The programming procedure is explained below and the following table shows the range of values and defaults.

Menu Buttons

General:

The Micro II starter controller has a display/keypad (see Figure 38) that allows the user to set the starter parameters using a plain English interface. The functions of the display buttons are as follows.



Press to enter the menu system.
Press to abandon changes made to a parameter (before pressing the Enter key).
Press to exit a sub-menu.
Press to exit the menu system.



Press to enter a menu.
Press to enter a sub-menu.
Press to change the parameter displayed.
Press to store the new value entered.

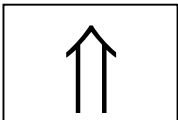

Select the menu to enter.
Select the sub-menu to enter.
Scroll between parameters when in a specific menu or sub-menu.
Increase a parameter value.
Press to view the meters when the main display is shown.

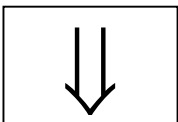

Select the menu to enter.
Select the sub-menu to enter.
Scroll between parameters when in a specific menu or sub-menu.
Decrease a parameter value.
Press to view the meters when the main display is shown.



Press to start the motor when the starter is connected for local display control.
Press to activate the BIST (Built-In Self test)
If 2-wire control is used or the Start button is disabled, this button is inoperative.



Press to stop the motor when the starter is connected for local display control.
If 2-wire control is used or the Stop button is disabled, this button is inoperative.

Menu Structure

The Micro II control has a 2 level menu structure. There are eight main menus that contain parameters related to the different functions of the starter and five of the main menus contain additional sub-menus that divide the parameters into functional groups. The following shows the structure of the menu structure.

Table 39, Main Menu

Quick Start	Motor Nameplate	Starter Setup	Motor Protection	Meters & Relays
		Starter Modes	Overload Class	Meters Setup
		Forward1 Profile	Line Current	Standard Relays
		Forward2 Profile	Line Voltage	Extended Relays
		Tachometer Setup	Line Frequency	
		Decel Setup	Ground Fault	
		Port Ctl Setup	Shorted Scr	
		True Torque Ramp	Over Curr. Trip	
			Under Curr. Trip	
			Start Lockouts	
			Starting Timers	
			Permissive Input	
			Misc.	
			Fault Classes	

Continued

Event Recorder	Control Config	Factory Setup	RTD Setup
	System Clock	Hardware Setup	Rtd Module Setup
	System Password	Bist Setup/Run	Rtd Setpnts 1-8
	Comm. Settings	Factory Control	RTD Setpnts 9-16
	Options List		
	Software Part#		

Changing a Parameter

To change a parameter, follow these steps;

- View the desired parameter by following the “Viewing a Parameter” instructions.
- Press the Enter button to switch to the change parameter screen.
- Press the Up or Down buttons to get the desired value on the screen.
- Press the Enter button to store the new value.

Example

The ramp time is set to 30 seconds and it is to be changed to 20 seconds.

The following steps must be taken to change the ramp time.

- Press the Menu button to enter the menu system.
- Press the Down button twice to get to the Starter Setup screen.
- Press the Enter button to access the Starter Setup menu.
- Press the Down button once to display the Forward1 Profile.
- Press the Enter button to access the Forward1 Profile sub-menu.
- Press the Down button twice to display the Ramp Time parameter.
- Press the Enter button to allow a change to the ramp time.
- Press the Down button repeatedly to change the Ramp Time to the desired value.
- Press the Enter button to store the value.
- Press the Menu button repeatedly to return to the main display.

Quick Start

Motor FLA

Parameter Description

The motor FLA parameter must be set to the full load amps of the motor connected to the starter for the starter to function correctly.

NOTE: The starter uses the entered motor FLA for every current based calculation. If the motor FLA is not entered correctly, the current ramp profile and many of the starter's advanced protection features will not function properly.

Parameter Values

The motor FLA parameter is adjustable from 1 to 1200 amps in 1-amp increments.

Parameter Default

The default value for the motor FLA is 1 amp.

Serv. Fact (Service Factor)

Description

The service factor parameter should be set to the service factor of the motor. The service factor is used for the overload calculations. The service factor is factory set, will be checked by the start-up technician and should not require further adjustment. If the service factor of the motor is not known, then the service factor should be set to 1.00.

Values

The service factor can be set from 1.00 to 1.99, in 0.01 increments.

NOTE: The NEC (National Electrical Code) does not allow the service factor to be set above 1.40. Check with other local electrical codes for their requirements.

Default

The default value for the service factor is 1.15.

Start Mode

Description

The Start Mode parameter allows for an optimal start of the motor based on the application. For a description of the possible Start Mode parameters, refer to page 31 in the Operations chapter.

Values

The Start Mode Parameter can be set to Curr, TT, or Tach.

Default

The default value for the Start Mode is Curr.

Stop Mode

Description

The Stop Mode parameter allows for the most suitable stop of the motor based on the application. For a description of the possible Stop Mode parameters, refer to page 31 in the Operations chapter of the starter manual.

Values

The Stop Mode can be set to Coas, VDCL, or TT.

Default

The default value for the Stop Mode is Coas.

Int. Curr. (initial current)

Description

The initial current parameter is set as a percentage of the motor FLA parameter setting. The initial current parameter sets the current that will initially reach the motor when a start is commanded.

If the motor does not rotate within a few seconds after a start command, the initial current should be increased. If the motor takes off too quickly after a start command, the initial current should be decreased.

The initial current must be set to a value that is lower than the maximum current parameter setting.

A typical setting for the initial current parameter is from 50% to 175%.

Values

The initial current is adjustable from 50% to 400% in 1% intervals.

Default

The default value for the initial current is 100%.

Max. Curr. (maximum current)

Description

The maximum current parameter is set as a percentage of the motor FLA parameter setting. The maximum current parameter performs two functions. It sets the current for the end of the ramp profile and sets the maximum current that is allowed to reach the motor while the motor is being started.

If the ramp time expires before the motor has reached full speed, the starter will hold the current at the maximum current level until the stall time expires, the motor reaches full speed, or the overload trips.

Typically, the maximum current is set to 600% unless the power system or load dictates the setting of a lower maximum current.

Values

The maximum current is adjustable from 100% to 600% in 1% intervals.

Default

The default value for the maximum current is 600%.

Ramp Time

Description

The ramp time sets the amount of time that it takes for the starter to linearly increase the current from the initial current level to the maximum current level. A typical ramp time setting is from 15 to 30 seconds.

Settings

The ramp time is adjustable from 0 to 120 seconds in 1 second intervals.

Default

The default value for the ramp time is 15 seconds.

Overload

Description

If there is more than one motor connected, the motor FLA should be set to the sum of the connected motor full load.

amps.Values

Class 1 to 40 in steps of 1.

Default

The default value for the overload parameter is 10.

Phase Order

Description

The line phasing parameter sets the phase sensitivity of the starter. This can be used to protect the motor from a possible change in the incoming phase sequence. If the incoming phase sequence does not match the set phase rotation, the starter will display *phs err* while stopped and will fault if a start is attempted.

Values

The line phasing can be set to:

- INS - will run with either phase sequence
- ABC - will only run with ABC phase sequence
- CBA - will only run with CBA phase sequence

Default

The default value for the phase sensitivity parameter is INS.

Troubleshooting

The following troubleshooting charts can be used to help solve some of the more common problems that occur.

Table 40, Motor will not start, no output to motor.

Display	Cause	Solution
Fault Displayed.	Shown on display.	See fault code table.
Watchdog LED on.	CPU card problem.	Consult McQuayService.
Display is blank.	Control voltage is absent. FU1 on power card. Ribbon Cables.	Check for proper control voltage. Replace FU1. Check ribbon cables.
Stopped	Control Devices Display buttons disabled.	Check control devices Enable display buttons.
No line	Missing at least one phase of main power	Check power system.

Table 41, Motor rotates but does not reach full speed.

Display	Cause	Solution
Fault displayed.	Shown on display	See fault code table.
Accel or Running	Mechanical problems. Abnormally low line voltage.	Check for load binding. Check motor. Fix line voltage problem

Table 42, Deceleration profile not operating correctly.

Display	Cause	Solution
Motor stops too quickly.	Time setting, or improper level setting.	Contact McQuayService
Time seems correct but motor surges at start of decel.	Decel level 1	Contact McQuayService
Time seems correct but motor stops before cycle complete.	Decel level 2. TruTorque DCL End Torque	Contact McQuayService
Time seems correct but water hammer occurs at end of cycle.	Decel level 2. TruTorque DCL End Torque	Contact McQuayService

Table 43, Motor stops while running.

Display	Cause	Solution
Fault displayed.	Shown on display.	See fault code table.
Display is blank.	Control voltage is absent. FU1 on power card	Check control wiring and voltage. Replace fuse.
Stopped	Control devices.	Check control system.

Table 44, Other situations.

Display	Cause	Solution
Power Metering not working.	CT installed wrong.	Fix CT installation. White dot to line side.
TruTorque Ramp not working.	CT installed wrong.	Fix CT installation. White dot to line side
Motor current or voltage fluctuates with steady load.	Motor Energy saver Power connection.	Verify motor is operating correctly. Set energy saver to off. Shut off power and check connections
Erratic operation.	Loose connections.	Shut off all power and check connections.
Accelerates too quickly.	Ramp time. Initial current. Maximum current setting. Kick Start. Improper FLA setting. Initial torque. Maximum torque.	Contact McQuayService
Accelerates too slowly	Ramp time. Initial current. Maximum current setting. Kick Start. Improper FLA setting. Initial torque. Maximum torque.	Contact McQuayService
Motor overheats.	Duty cycle. High ambient. Too long acceleration time. Wrong overload setting. Too long jog cycle.	Cool between starts. Provide better ventilation. Reduce motor load. Select correct overload setting. Jog operation reduces motor cooling and increases current. Shorten jog cycle.
Motor short circuit.	Wiring fault. Power factor correction capacitors (PFCC) on starter output.	Identify fault and correct. Move PFCC to line side of starter.
Fans do not operate	Wiring. Fuse. Fan failed.	Check wiring and correct. Replace fuse. Replace fan.
Display buttons don't work.	Display ribbon cable. Display faulty.	Check cable on back of display. Replace display.

Fault/Log Codes

The following is a list of the possible fault and log codes that can be generated depending on the type of starter.

The fault class lists the default setting for each fault; either critical or non-critical.

NonC = Non-critical Crit = Critical

Table 45, Fault/Log Codes

Fault/Log No.	Fault Class	Fault/Event Recorder Text	Description/Possible Solutions
1	NonC	Sequence Not CBA	Incoming phase sequence is actually ABC but starter is set to CBA
2	NonC	Sequence Not ABC	Incoming phase Sequence is actually CBA but starter is set to ABC
3	NonC	No Phase Order	No phase order detected.
4	NonC	High Freq. Trip	Line frequency went above the high freq. trip setting Line power quality problem. Low control power problem. Generator governor is malfunctioning
5	NonC	Low Freq. Trip	Line frequency went below the low freq. trip setting Line power quality problem. Low control power problem. Generator governor malfunctioning.
6	NonC	Jog Not Allowed	Jog input (JC13-4) was energized while the starter was running. Stop the starter by removing the run command before requesting a jog (JC13-4).
7	NonC	100% Not Allowed	The jog input (JC13-4) was de-energized while the starter was operating in the jog mode. Stop the starter by removing the run command before removing the jog command (JC13-4).
9	NonC	Dir Change Fault	The jog direction was changed while the starter was operating in the jog mode. Stop the starter by removing the run command before changing the state of the reversing input (JC13-6).
15	Crit	Phase Order Err	Phase order error.
16	Crit	Bad OP Code Err	Bad operating-code error
17	NonC	Over voltage L1	The voltage on line 1 went above the high/low voltage setting
18	NonC	Over voltage L2	The voltage on line 2 went above the high/low voltage setting
19	NonC	Over voltage L3	The voltage on line 3 went above the high/low voltage setting
20	NonC	Low line voltage#1	The voltage on line 1 went below the high/low voltage setting
21	NonC	Low line voltage#2	The voltage on line 2 went below the high/low voltage setting
22	NonC	Low line voltage#2	The voltage on line 3 went below the high/low voltage setting
23	NonC	Curr. Imbal. HL1	The current on line 1 went above the current imbalance setting
24	NonC	Curr. Imbal. HL2	The current on line 2 went above the current imbalance setting
25	NonC	Curr. Imbal. HL3	The current on line 3 went above the current imbalance setting
26	NonC	Curr. Imbal. LL1	The current on line 1 went below the current imbalance setting
27	NonC	Curr. Imbal. LL2	The current on line 2 went below the current imbalance setting
28	NonC	Curr. Imbal. LL3	The current on line 3 went below the current imbalance setting
29	Crit	Bad RAM Battery	Bad RAM battery. Replace IC16 or computer card to correct problem. To clear fault, hold the down arrow key and perform a computer reset. Continue holding the down arrow key until fault 30 appears on the display
30	Crit	Def Param Loaded	The factory defaults for the parameters have been loaded. Reset the computer to clear the fault. All parameters have to be re-programmed as necessary.
31	NonC	REV Not Allowed	Starter is not a reversing unit. Remove reverse command from reverse input (JC13-6).
46	NonC	BIST Canceled	The Built-in Self Test was canceled. The disconnect was closed. Line power was applied to the starter.
49	NonC	Tach Loss	There was no tachometer feedback signal detected when a start was commanded.

Continued on next page.

Fault/ Log No.	Fault Classes	Fault/Event Recorder Text	Description/Possible Solutions
50	Crit	Key Pad Failure	The door mounted keypad has failed. The Stop or Start button was held down while a computer reset was performed or while power was applied to the unit.
51	Crit	TT Overcurrent Limit	During TruTorque ramping, the motor current exceeded the TruTorque Overcurrent Trip level
52	Crit	Curr. At Stop	Current flow above the no current at run setting was detected while the starter was stopped. Examine starter for shorted SCRs.
53	NonC	No Curr. At Run	The motor current went below the no current at run setting while the starter was running. The load was disconnected while running. The motor is being driven by the load.
56	NonC	Phase Detection	
64	Dis	Bad RTD Detected	A bad RTD was detected (open or shorted lead).
65	NonC	RTD Alarm Limit	A RTD alarm set point was exceeded.
66	NonC	RTD Comm Loss	Communications with the RTD module was lost. Check RS-485 wiring between the RTD module and card. Check 24VDC RTD module power supply.
67	NonC	PWR DIP data Lost	PWR DIP data lost
68	NonC	Jog Timer Limit	The jog timer (see page) expired. Examine reason for extended jog operation.
69	NonC	Zero Speed Timer	The zero speed timer (see page 71) expired. • Check motor for jammed or overloaded condition
70	NonC	Low Control PWR	Control power is too low. Examine control power transformer input and output voltages. Check wiring between control power source and starter.
71	NonC	Ground Fault	A ground fault current above the ground fault setting was detected.
72	Crit	DIP SW set Wrong	CT burden DIP switch set incorrectly. Set switches correctly (see page 21).
73	NonC	Bypass Fault	The bypass contactor failed to stay energized. Check separate bypass for proper wiring. Check integral bypass (RSxB units) control card fuses.
74	NonC	UTS Timer Limit	The motor was not at full speed before the UTS time expired. Check motor for jammed or overloaded condition.
75	NonC	External Trip	Power was removed from the external trip input on the computer card (JC13-1). Trip input delay is set to short
76	Crit	Disconnect Open	A start was commanded while the disconnect was open.
77	NonC	In-line Fault	The in-line contactor did not close. Check wiring to coil of contactor. Check feedback wiring from auxiliary contactor to JC13-4 terminal. check in-line fault delay
78	NonC	Over Curr Trip	The current went above the over-current trip setting
79	NonC	Under Curr Trip	The current went below the under-current trip setting
80	NonC	High Field Curr.	The field current was above the maximum field current setting. • Examine parameter settings for improper adjustment. • Examine field for problem causing the high field current
81	NonC	Field Loss	There was no synchronous field current. Check wiring and motor for open field circuit.
82	NonC	Loss of SYNC	The motor came out of synchronization while it was operating. Examine the motor load for an overload. Increase the field current up to the maximum for the motor. Change from power factor control to current control mode for a varying load
83	NonC	High PF Trip	The motor power factor went above the high power factor trip setting.
84	NonC	Low PF Trip	The motor power factor went below the low power factor trip setting.
87	NonC	Incomplete Seq.	The motor was not synchronized before the sequence timer expired.
90	Crit	OL Lock	Used to set the operation of the overload.

Continued on next page.

Fault/Log No.	Fault Classes	Fault/Event Recorder Text	Description/Possible Solutions
91	Crit	Unauthorized RUN	The start/stop circuitry has failed. A fast start/stop sequence was performed. Check wire connected to terminal JC13-3.
92	Crit	Shorted SCR	A shorted SCR on line 1 was detected • Check all 3 SCRs for shorts
93	Crit	Shorted SCR	A shorted SCR on line 2 was detected. Check all 3 SCRs for shorts
94	Crit	Shorted SCR	A shorted SCR on line 3 was detected Check all 3 SCRs with ohmmeter for shorts.
95	Crit	Shorted SCR	Shorted SCRs on line 2 and 3 were detected Check all 3 SCRs with ohmmeter for shorts.
96	Crit	Shorted SCR	Shorted SCRs on line 1 and 3 were detected Check all 3 SCRs with ohmmeter for shorts.
97	Crit	Shorted SCR	Shorted SCRs on line 1 and 2 were detected Check all 3 SCRs with ohmmeter for shorts.
98	NonC	No Mains Power	A start was commanded while no line power was detected.
99	Crit	I. O. C.	A very high current was detected. Check the motor and wiring for short circuits.
101		Blank Log	Blank Log.
102		Log:Disconnect O	Log:Disconnect open.
103		Log:DIR Change	The direction of the starter was changed.
104		Start Commanded	A start command was given.
105		Stop Commanded	A stop command was given.
106		Stop Complete	The stop sequence is complete and the starter has removed power from the motor.
107		Log: System UTS	Log: System UTS (up to speed).
147		Log:BIST Entered	Log:BIST entered.
148		Log:BIST Passed	Log:BIST passed.
154		Log:Password CLR	Log:Password cleared.
155		Log:Events CLR	Log:Event log cleared.
156		Log:System Reset	Log:System Reset.
157		Log:Hardware PWR UP	Log:Hardware PWR UP.
158		Log:Emerg Reset	Log:Emergency reset.
159		Log:Time Changed	Log:Time changed.
160		PWR Ret BYP IN	Line power returned while the bypass contactor was in.
161		PWR Ret BYP OUT	Line power returned after the bypass contactor was dropped out.
162		PWR Loss Voltage	PORT mode was entered due to low line voltage.
163		PWR Loss Current	PORT mode was entered due to loss of current.
164		PORT BYP Open	Bypass contactor was dropped out while in PORT mode.
165		Log:System Reset	The unit was reset.
169		RTD Warn Limit	One of the RTD warning set points was exceeded.
185		Log:Loss of SYNC	Log:Loss of SYNC.
186		Log:If Ctrl Mode	Log:If Ctrl Mode.
188		Log:By-Pass Drop	The integral bypass contactors dropped out and were re-energized. Possible short term drop in line voltage.
189		Log:OL Warn	The thermal overload went above 90% thermal content.
190		Log:OL Lock	The thermal overload tripped. Check motor and load for cause of overload.

LED Diagnostics

There are several LEDs located on the Micro II circuit cards. These LEDs can be used to help troubleshoot problems with the starter. Refer to the circuit card layouts for LED locations.

Table 46, LED Diagnostics

CARD	LED #	NAME	INDICATION
Computer	LEDC1	Watch Dog/Power Fail/Reset	On when reset/CPU failure/control voltage failure.
	LEDC2	Control power	On if control voltage is present.
	NS	DeviceNet Network Status	See DeviceNet manual.
	MS	DeviceNet Module Status	See DeviceNet manual.
Local I/O Controller Card	DE	Data Enable	On when card is transmitting data.
	TXD	Transmit Data	On when card is transmitting data.
	RXD	Receive Data	On when card is receiving data.
	LED1	Operation	Flashes when card is operating.
	LED2	Communication	On when valid data is received over the master link.
Power	LEDP1 LEDP2 LEDP3	SCR Status	Indicates forward SCR condition;
			Stop - LEDs must be on or the SCR is shorted
			Start - LEDs will become dimmer as motor accelerates.
			Run - LEDs must be fully off or the SCR is open or misfiring.
Pulse Generator	L1 - L6	Condition of SCR's L1 and L2 - SCR's A and B L3 and L4 - SCR's C and D L5 and L6 - SCR's E and F	Indicates SCR condition; Stop - LEDs will be off when stopped. Start - LEDs will be bright when the in-line is energized. LED's will go progressively dimmer as motor accelerates. Run - LED's will be off when motor reaches full voltage.
	A - F	SCR gate voltage	These LEDs will be on, while ramping, to indicate that gate power is reaching the SCR's.

Preventive Maintenance

During Commissioning

- Torque all power connections during commissioning, including pre-wired equipment.
- Check all control wiring for loose connections.
- If fans are installed, check for proper operation.

One Month After Commissioning

- Re-torque all power connections, including pre-wired equipment.
- If fans are installed, check for proper operation.

After First Month of Operation

- Re-torque all power connections, including pre-wired equipment annually.
- Clean accumulated dust with clean compressed air.
- Inspect cooling fans, if present, every three months.
- Clean or replace air vent filters every three months.

Sequence of Operation

Thermal Expansion Valve, Models 079 - 126

The following sequence of events describes a typical WDC start and subsequent compressor staging process (on multi-compressor applications). No attempt is made in this section to describe all the contingency features of the code. The purpose of this section is to provide the operator with some insight into how the centrifugal chiller distributed control process works to start and stage compressors.

The code is laid out to ultimately control four chillers with four compressors on each chiller. The polling routine described below searches for all possible compressors (16 total), even though there may be only one compressor involved. The code works the same for a stand alone WSC model, which is a simple one-compressor case, or a dual compressor, WDC, setup. The Max Comp On setpoint is used to limit the number of compressors that can run at one time (not the number being polled).

Chiller Starting

1. When the Unit state is switched to Auto, the compressors on a dual, or multi-compressor setup, poll each other (1 to 2 minutes) to determine which will be NEXT_ON. The outcome of the NEXT_ON search is determined by the Staging Sequence selected by the operator. Only one compressor at a time can be selected to be NEXT_ON, and only compressors without active alarms. The NEXT_ON status is indicated by lighting the right arrow button on that compressor's controller keypad. If the NEXT_ON compressor has Start-to-Start or Stop-to-Start timers running, the chiller will wait for them to clear. On WCC chiller, the #2 compressor (leaving chilled water side) is always the first on.
2. When the Unit controller receives the NEXT_ON flag from one of it's compressors, it will start it's Evap Pump (Evap Start State) and wait for the Recirculation time, at a minimum, then it will wait "till the end of time" for the flow switch to close. When flow is confirmed, the Evap State will switch to Run.
3. Approximately one min after NEXT_ON is set in the compressor, the compressor will look at the Evap LWT to determine if Start-Delta-T has been exceeded. If so the Stage-Up-Now flag is set, and if Evap State equals Run, the compressor start sequence will begin [Comp Start (oil pump) state].
4. When the required net oil pressure is achieved, the compressor will transition to PreLube state and when the Vanes_Closed switch is made (compressor cleared to start) the Unit controller will start the Condenser Pump.

If the Vanes_Closed_switch is not made within the Prelube time plus 30 seconds, a Vanes-Open-No-Start alarm is declared.

If condenser flow is not established within a time period after the vanes closed signal, a Condenser Flow alarm is declared. The time period is equal to the Prelube time plus 30 seconds. **Note:** It is possible for the Prelube state to successfully run for twice the Prelube time plus 60 seconds, and not create an alarm.

5. In order to transition from Prelube to Compressor run state the following flags must be set: Unit_State_Auto, Evap_State_Run, Cond_State_Run, Vanes_Closed, and Prelube timer expired. Given this the lead compressor will start.

Compressor Staging

1. If the Normal (default) Staging Sequence on a WDC chiller is selected, and a compressor (the lead) has just started, the lag compressor's polling routine will declare it as the NEXT_ON compressor.
2. On WCC, counter flow chillers, the #2 compressor (leaving chilled water side), is the lead compressor, first on, last off. Should the # 2 compressor fail to start, the #1 compressor will start and handle the load to the extent of its capacity.
3. Once the lead compressor has satisfied the Soft Loading requirement, and judged to be at Full Load, the Lag compressor (on multiple compressor applications) will determine when to stage up as follows.
4. The Lag compressor will initiate a start sequence when the following events occur: a) Full Load flag received from lead compressor, b) Evap LWT slope is less than minimum pull down rate, c) Evap LWT exceeds the Stage-Delta-T setpoint.
5. The initial step in the Lag start sequence is to send a flag to the lead compressor causing it to continuously unload the vanes for the duration of two Postlube time periods. This reduces the head pressure that the lag compressor will have to overcome when it starts. Note that after the two Postlube periods, the lead compressor will load back up regardless of the lag compressor's run status.
6. The lag compressor will wait for a period of time equal to the Postlube minus the Prelube time before starting its oil pump. This coordinates the two compressors so that as the lead unloads to the vanes closed condition, the lag compressor is completing the Prelube state and both compressor are released to load up together. One minute after the lag compressor starts, Amp balancing takes affect to share the load.

Determining Full Load Status

Since the chiller's Full Load status doesn't correspond to %RLA, a direct comparison cannot be made. That is to say that the chiller can be running flat out (vanes fully open) at 90 %RLA. The %RLA number is greatly affected by the chiller's operating conditions (i.e. condenser water, evap Delta-T).

The following describes the six parameters used to set the Full Load indication for a compressor.

1. Vane position – Vane position is not measured directly. On Chillers with a VFD, a switch is used to detect "Vanes_Open". Chiller's without a VFD use a "Full Load" timer (Set Comp SPs (4). This timer sums the time that the load vanes solenoid is pulsed. Any unload pulses will reset the timer. When the continuous load pulse time exceeds the setpoint the Vanes_Open flag is set.
2. VFD Speed - A flag is set if the VFD is equal or above 100% speed.
3. Max_Amps - A flag is set if %RLA is equal to, or above Max_Amps.
4. Demand Limit - A Flag is set if %RLA is equal to, or above a % demand limit (either 4-20mA signal or network amp limit).
5. Max Capacity based on pressure - A Flag is set if Evap Saturated Pressure is equal to, or below the Evap Inhibit loading setpoint "LowEvPrHold" found under SET ALARM LMTs (1).
A low refrigerant charge can cause this flag to be set at lower than expected capacity, but it is still an indication that the chiller has reached maximum capacity.
6. Soft loading - If the operator has enabled the SoftLoad feature, the first compressor (on the pLAN network) to run will inhibit the following flags while the SET UNIT SPs (6) "SoftLoadRamp" timer is running; Vanes_Open, Max_Amps, Demand Limit, and Max Capacity.

The Compressor's Full Load Status indication is configured into two modes, with and without VFD.

1. With VFD - Full Load is indicated with Vanes_Open and VFD Speed ($\geq 100\%$).
2. Without VFD - Full Load is indicated when SoftLoad is not active, and any of the following logic or flags are set; Vanes_Open, Max-Amps, Demand Limit, or Max Capacity (pressure).

The unit's (chiller) Full Load indication sent out over the BAS interface (bit #0 of Integer 22) is set if the number of compressors (on this chiller) running at Full Load is equal to, or greater than the sum of compressors running and available to run (on this chiller). A compressor is considered available if both Start and Stop timers are clear, inhibit switches and flags are set to enable, No Alarms pending, and the compressor is on-line (pLAN); or the compressor is running and on-line.

Available compressors (bits 1-4 of Integer 22) are inhibited if Unit Mode Source is not set to Network (BAS), however the Unit Full Load indication will be valid regardless of the Source type.

Electronic Expansion Valve, Models 050 - 063

The following text describes the operation and sequence of events currently used to control the electronic expansion valve equipped units.

Chiller Starting

When the Unit state is switched to Auto, the compressors poll each other (1 - 2 min.) to determine which will be NEXT_ON. The outcome of the NEXT_ON search is determined by the default Staging Sequence or one selected by the operator. Only one compressor at a time can be selected to be NEXT_ON, and only compressors without active alarms. The NEXT_ON status is indicated by lighting the right arrow button on that compressor's controller. If the NEXT_ON compressor has Start-to-Start or Stop-to-Start timers running, the chiller will wait for them to clear (this would be an abnormal event).

1. When the Unit controller receives the NEXT_ON flag from one of its compressors, it will close Relay #7 for two seconds. This prompts the valve to close and re-calibrate its stop (closed) position. The re-calibration ("Pump Down") process normally takes 10 seconds (1 minute max.) to complete. After re-calibration is complete, the valve should remain closed. During this time the Evap Pump starts (Evap Start State) and waits until flow is confirmed before switching the Evap State to Run.
2. Approximately one minute after NEXT_ON is set in the compressor, the compressor will look at the Evap LWT to determine if Start-Delta-T has been exceeded. If so, the Stage-Up-Now flag is set, the valve opens fully, and if Evap State equals Run, the compressor start sequence will begin [Comp Start (oil pump) state].

When the required net oil pressure is achieved, the compressor will transition to PreLube state and when the Vanes_Closed switch is made (compressor cleared to start), the Unit controller will start the Condenser Pump.

- If the Vanes_Closed switch is not made within the Prelube time plus 30 seconds, a Vanes-Open-No-Start alarm is declared.
- If condenser flow is not established within a time period after the vanes closed signal, a Condenser Flow alarm is declared. The time period is equal to the Prelube time plus 30 seconds.

Note: It is possible for the Prelube state to successfully run for twice the Prelube time plus 60 seconds, and not create an alarm.

3. In order to transition from Prelube to Compressor Run state, the following flags must be set: Unit_State_Auto, Evap_State_Run, Cond_State_Run, Vanes_Closed, and Prelube timer expired. Given this, the lead compressor will start.

Chiller Pull-Down

1. Working under Evap Pressure control, the valve will slowly close during the Pull-Down process.
2. When the Evap leaving water temp has been pulled below the Drop Out (DO AA.A°F) set point, the valve will switch to Program control. Which uses an equation based on Condenser delta Temp and Lift temperature to position the valve.
3. An Error signal is derived from the suction superheat and liquid approach parameters, and used to make fine offset adjustments to the valve's position.

Evaporator Drain Function

If the chiller is off, and the evaporator entering water temp equals the condenser entering water temp, the expansion valve will open 30% to allow refrigerant to drain back into the condenser vessel.

Operating the Chiller Control System

Interface Panel On/Off

The Operator Interface Panel is turned on and off with a push-push switch located at the upper-left corner on the rear of the panel. ON is the outermost switch position and a white band will be visible on the switch stem. Off is innermost and no white is visible.

The screen is equipped with a screen saver that blackens the screen. Touching it anywhere reactivates the screen. If the screen is black, touch it first to be sure it is on before using the ON/OFF switch.

Start/Stop Unit

There are four ways to start/stop the chiller. Three are selected in SETPOINT\MODE\SP3, the fourth way is through panel-mounted switches:

Operator Interface Panel (LOCAL)

Home Screen 1 has AUTO and STOP buttons that are only active when the unit is in "LOCAL CONTROL". This prevents the unit from being accidentally started or stopped when it is under control from a remote switch or BAS. When these buttons are pressed, the unit will cycle through its normal starting or stopping sequence. On dual compressor units, both compressors will be stopped and normal dual compressor starting procedure will be in effect.

Remote SWITCH

Selecting SWITCH in SP3 will put the unit under the control of a remote switch that must be wired into the control panel (see Figure 2 on page 11).

BAS

BAS input is field-wired into a card that is factory-installed on the unit controller.

Control Panel Switches

The unit control panel, located adjacent to the Interface Panel has switches inside the panel for stopping the unit and compressors. When the UNIT switch is placed in the OFF position the chiller will shut down through the normal shutdown sequence whether one or two compressors.

The COMPRESSOR switch(s) (two on dual compressor units) will immediately shut down the compressor without going through the shutdown sequence when placed in the OFF position. It is equivalent to an emergency stop switch.

Change Setpoints

Set points are easily changed on the Operator Interface Touch Screen (OITS). A complete description of the procedure begins on page 22. Set points can also be changed in the unit controller but this is not recommended except in an emergency when the OITS is unavailable.

Alarms

A red ALARM light in the lower middle of any screen is illuminated if there is an alarm. If the optional remote alarm is wired in, it too will be energized.

There are three types of alarms:

- FAULT, equipment protection alarms that shut a unit or compressor off.
- Problem, limit alarms that limit compressor loading in response to an out-of-normal condition. If the condition that caused a limit alarm is corrected, the alarm light will be cleared automatically.
- Warning, notification only, no action taken by controller.

Any type will light the ALARM light. Procedures for dealing with alarms are shown below:

1. Press the alarm light button. This will go directly to the ACTIVE ALARMS screen.
2. The alarm description (with date stamp) will be shown.
3. Press the ACKNOWLEDGE button to recognize the alarm.
4. Correct the condition causing the alarm.
5. Press the CLEAR button to clear the alarm from the controller. If the fault condition is not fixed, the alarm will continue to be on and the unit will not be able to be restarted.

Control Component Failure

Chiller Operation without the Operator Interface Panel

The Interface Panel communicates with the unit and compressor controllers, displaying data and transmitting touch screen inputs to the controllers. It does no actual controlling and the chiller can operate without it. Should the Touch Screen become inoperable, no commands are necessary for continuing unit operation. The unit controller can be used to view operational data and to change setpoints if necessary.

Chiller Operation without the Unit Controller

The Touch Screen receives most of its operational data from the unit controller and if the unit controller is not operational considerable data will be absent from the screen. Tower control of fans and/or bypass valve will be disabled and tower operation will be interrupted and require manual intervention to continue operation.

