

Micro-Processor

Code 20

<u>Service Bulletin Number</u>	<u>Service Bulletin Title</u>
20-8901-B	MicroTech Remote Operation
20-8902-B	MicroTech Test Fixture
20-8903-B	MicroTech low Motor Current Nuisance Fault
20-9004-B	MicroTech Fault Relay Substitution
20-9005-B	Direct Connect Cable for MicroTech Panels
20-9006-B	MicroTech Control Panel Random Starter Faults
20-9007-B	MicroTech AC/DC Convertor Board
20-9208-B	Low Oil Pressure Nuisance Trips
20-9209-B	MicroTech LLB Version DUA08D
20-9210-B	Centrifugal MicroTech Output Board Fuses
20-9211-B	Centrifugal Voltage Regulator Retrofit
20-9312-B	MicroTech LLLB Panel Software Revision
20-9313-B	Centrifugal Chiller Display Failures
20-9414-B	Monitoring Multiple Units With A Single Modem
20-9115-B	Electronic Wiring Connectors for MicroTech Panels
20-9416-B	Lead-Lag Load Balance with MicroTech
20-9417-B	Rooftop MicroTech Space Sensor #2 - Erroneous Readings
20-9418-B	MicroTech Centrifugal Daughter Board
20-9519-B	Dry Running Centrifugal Starters 100- Series (old) MicroTech
20-9520-B	Series 200 Centrifugal MicroTech Panel
20-9521-B	CNS Standard- 201, "Network Architecture"
20-9522-B	Series 200 MicroTech
20-9623-B	200 Series MicroTech Starting Alarms/Faults
20-9624-B	PFS A Vintage with Remote Air Cooled Condenser
20-9625-B	AOX-4 Board Installation
20-9626-B	APROTEX (brand name) Modem
20-9627-B	Series 200 MicroTech PF units or Dual PE Units with Lead-Lag Configuration
20-9628-B	200 Centrifugal Software Version CFGxx03D and later
20-9629-B	EPL Timers
20-9730-B	MicroTech Low Motor Current Trips
20-9731-B	MicroTech Released Software
20-9732-B	MicroTech Released Software (Supersedes 20-9731-B)
20-9833-B	Software Download Procedure Change
20-9834-B	Updating PFS-C Units' Current Software
20-9835-B	MicroTech Released Software (Supersedes 20-98-32-B)

Micro-Processor

Code 20

<u>Service Bulletin Number</u>	<u>Service Bulletin Title</u>
20-9836-B	PFS-C Startup Procedure
20-9837-B	PFS-C FLU__ 02B.COD
20-9838-B	MicroTech Released Software (Supercedes 20-9835-B)
20-9939-B	Texas Instrument Low Pressure Transducers
20-9940-B	Chiller System Controller Issues
20-9441-B	Series 100 MircoTech Hours and Starts
20-9942-B	MircoTech Released Software (Supersedes 20-9838-B)
20-9943-B	Special Release of PFSC Software
20-9944-B	ALS 4 Compressor Software Modification Affecting SC4XX20P. Cod
20-9945-B	MicroTech Released Software (Supercedes 20-9942-B)
20-9946-B	MicroTech Released Software (Supercedes 20-9945-B)
20-0047-B	MicroTech Released Software (Supercedes 20-9946-B)
20-0048-B	Ribbon Cable Protection McQuay Software Passwords

McQuay Service Bulletin

Air Conditioning

SB Number 20-8901-B
Code 20

Date 11/3/89
Originator SL

Page 1 of 1
Supersedes _____

Microtech Remote Operation

We have received inquiries from customers who were not able to manually override the time schedule or clear faults remotely from their PC's. This capability is available in all versions of the Monitor program but its implementation is not always obvious. The following procedure should help clear up any customer concerns and a copy should be appended to the system screen description in the Monitor User's Manual.

1. Sign onto the system using the Monitor password listed on page 17 of the Monitor User's Manual.
2. From the main menu, select the "System" screen 1-4.
3. Press F-1 to change values. By pressing the "+" key, you can select one of the following functions:

Auto
Stop Unit
Start Unit
Clear Faults

4. With "Clear Fault" displayed on the prompt line, press <return>. The current panel fault will be cleared and the chiller should return to a "ready to start" condition.
5. By pressing the "+" key, the operator can manually start the chiller or select Auto which will place the chiller under control of the Microtech time schedule.
6. Press F-1 to resume monitoring the system. If no other mode was selected, the chiller control will revert to the Auto mode.

The MicroTech controller contains many safety systems which will shut down the chiller if a dangerous operating condition exists. Clearing a fault only resets the MicroTech safety systems, it will not fix the problem which caused the shutdown, therefore, it is extremely important to understand and correct the cause of the fault before restarting the chiller.

1411039.sl

McQuay Service Bulletin

Air Conditioning

SB Number <u>20-8902-B</u>	Date <u>11/3/89</u>	Page <u>1</u> of <u>2</u>
Code <u>20</u>	Originator <u>SL</u>	Supersedes _____

MicroTech Test Fixture

We periodically provide MicroTech software updates to our customers and service technicians in the form of pre-programmed cartridges. Since we don't always have a MicroTech panel available, we have assembled a test/programming fixture for use by our engineering and service staff. This has proven to be a very handy item and I am including a parts list and schematic for those interested in building a similar unit. The time and materials required for assembly is minimal and everything fits easily onto a 12 x 7 inch piece of plywood.

If locally purchased power transformers are substituted for the McQuay parts, they should be 24VAC center tapped and rated for 40VA. An in-line fuse holder containing a 2 amp fuse should be installed in series with the center tap of each transformer to protect the test fixture.

1411039a.sl

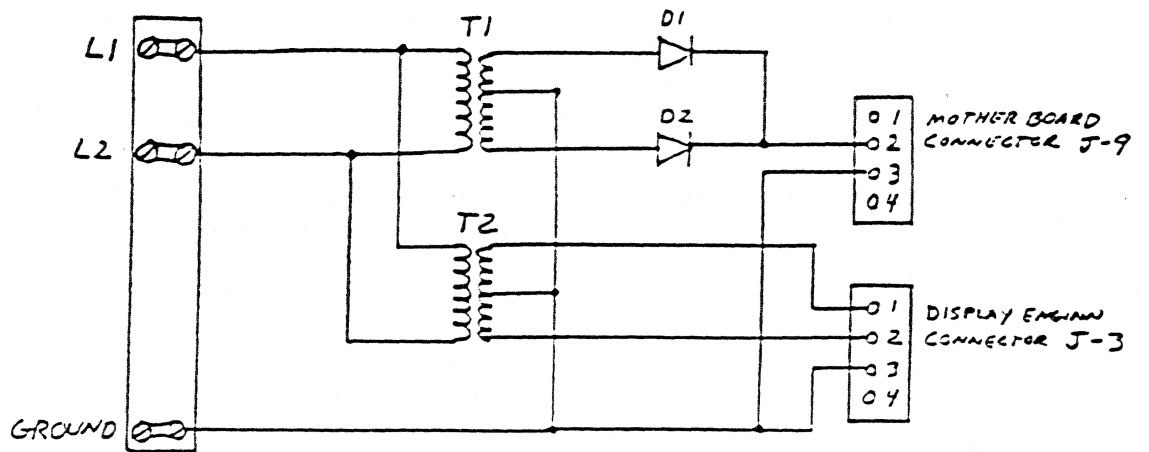

Ref	Part Number	Qty	Description
T1, T2	467361E-00	2	Transformer
D1, D2	350A034H04	2	1N4002 Diode
	707959AG01	1	Display Cable
	707959AG02	1	Control Cable
	707961AG01	1	Comm Cable
	492635B-01	1	Mother Board
	492634B-01	1	Power Cartridge

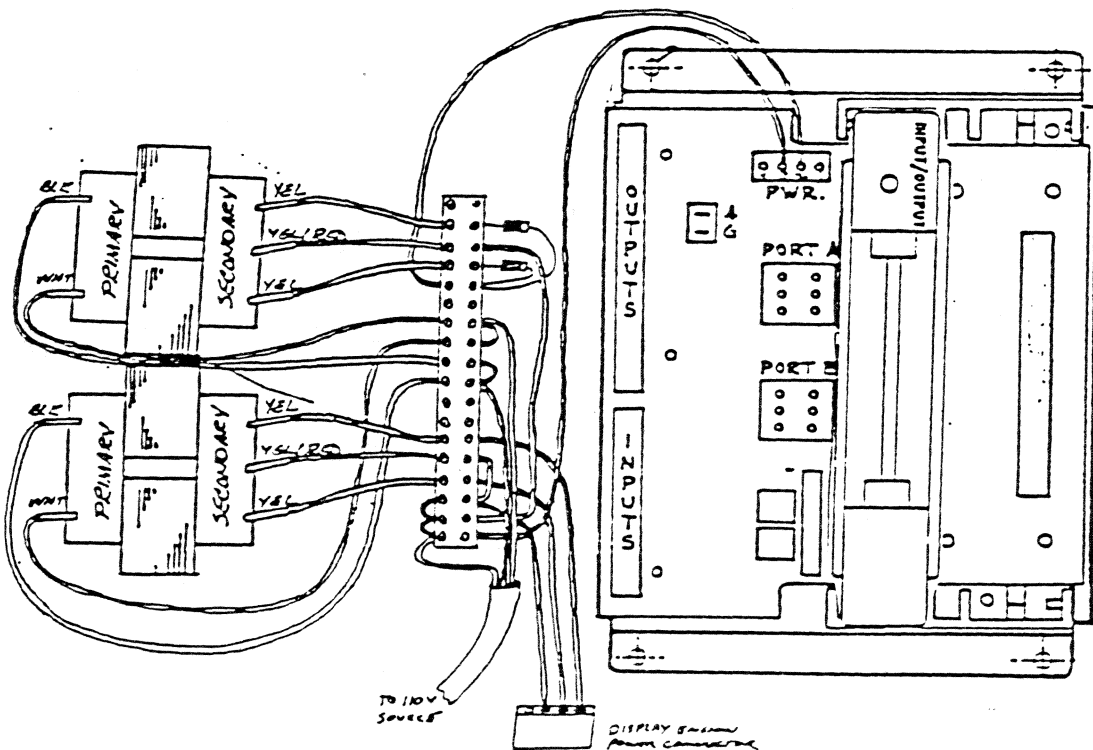

McQuay Service Bulletin

Air Conditioning

SB Number 20-8903-B
Code 20

Date 12/12/89
Originator SCL

Page 1 of 1
Supersedes _____

MicroTech Low Motor Current Nuisance Fault

We have received a few reports of MicroTech chillers tripping on a "Low Motor Current" fault while executing a normal shutdown on load recycle. This intermittent problem has been observed on machines running version 07 software and is not present with version 08 or greater. This intermittent problem is caused by the rapid decay of the motor current signal while the chiller is cycling down and can be eliminated by installing a 100 ufd, 10V electrolytic capacitor across terminals 1 & 2 of TS-2 on the AC/DC convertor board. Observe the polarity markings on the capacitor during installation and make sure the leads will not short to the cabinet or other components on the convertor board.

This fix may be implemented during a routine service call and does not require a special trip or software upgrade.

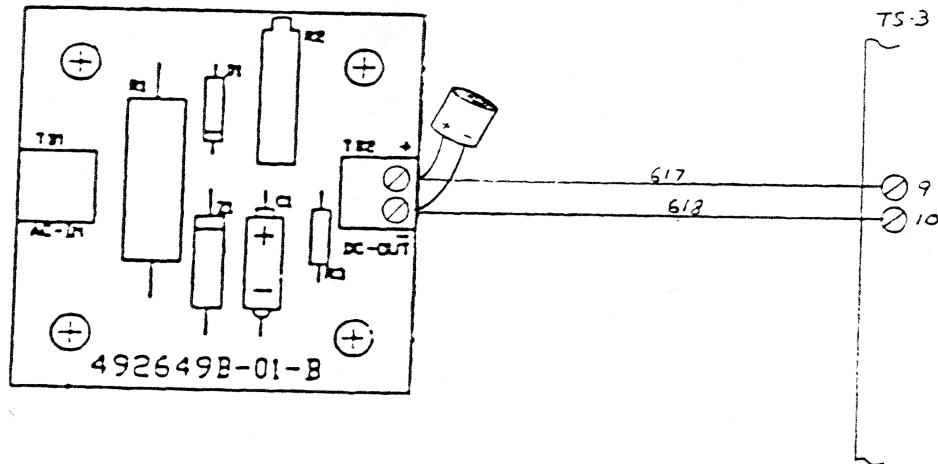

1412129.sl

McQuay Service Bulletin

Air Conditioning

SB Number 20-9004-B
Code 20

Date 1/12/90
Originator WGF

Page 1 of 1
Supersedes _____

MicroTech Fault Relay Substitution

The original Fault Relay used on Centrifugal MicroTech control panels was an instantaneous relay, part number 350A208H20, (Bubble number 201 in the MicroTech Parts Data dated March, 1988).

That fault relay has been replaced by a 3 second time delay relay, part number 350A729H09.

Whenever a Fault Relay fails requiring replacement, or when inexplicable nuisance tripping occurs and the display reads "Now = No Transition", we recommend that the instantaneous Fault Relay be replaced with the 3 second time delay relay identified above.

Original panels had only the one relay installed above the solid state terminal strip. That one relay is the "Fault Relay."

Later designed panels incorporated two (2) identical relays located above the solid state terminal strip.

The bottom one of these two is the Fault Relay. The upper one is the HP relay and it should continue to be the instantaneous relay originally used.

WGF:djn

McQuay Service Bulletin

Air Conditioning

SB Number 20-9005
Code 20

Date 4/17/90
Originator SL

Page 1 of 1
Supersedes _____

Direct Connect Cable For MicroTech Panels

This is the information you need to assemble a cable to connect your IBM compatible computer to a MicroTech control panel. The parts may be purchased locally from any electrical supply house. Use 8 to 10 feet of Beldon 8760 2-conductor cable with a foil shield and separate ground wire.

FEMALE
9 PIN
"D" SHELL
(COMPUTER)

6 PIN
AMP
CONNECTOR
(MOTHER BOARD)

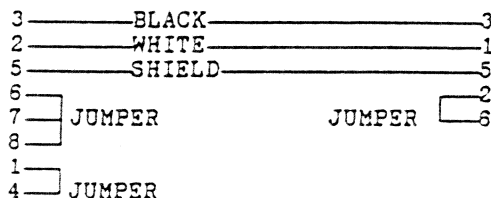

PARTS REQUIRED
9 PIN "D" CONNECTOR

(1) CONNECTOR	205203-1
(3) CONTACT	66504-9
(1) HOOD	205729-1
(2) RETAINER	205980-1

PARTS REQUIRED
6 PIN AMP CONNECTOR

(1) CONNECTOR	1-480270-0
(5) CONTACT	60617-4

FEMALE
25 PIN
"D" SHELL
(COMPUTER)

6 PIN
AMP
CONNECTOR
(MOTHER BOARD)

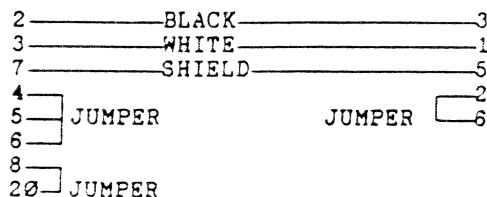

PARTS REQUIRED
25 PIN "D" CONNECTOR

(1) CONNECTOR	205207-1
(8) CONTACT	66504-9
(1) HOOD	205718-1
(2) RETAINER	205980-1

PARTS REQUIRED
6 PIN AMP CONNECTOR

(1) CONNECTOR	1-480270-0
(5) CONTACTS	60617-4

McQuay Service Bulletin

Air Conditioning

SB Number 20-9006-B
Code 20

Date 4/17/90
Originator SL

Page 1 of 1
Supersedes _____

MicroTech Control Panel Random Starter Faults

MicroTech control panels on McQuay centrifugal products use part # 350A208H20 in the high pressure cutout circuit. This relay is a Westinghouse part # MR2P24AC with a nominal coil voltage of 24VAC.

Typically, this relay will not drop out until the coil voltage drops to approximately 14.5 V however, some relays may be very sensitive to coil voltage fluctuations and will drop out at approximately 23 V. It has been observed that activating the SA/SB solenoid may cause the 24V supply to drop enough that the HP relay will drop out. This will cause the chiller to shutdown and display "STARTER FAULT" or "NO TRANSITION". The relay would then re-energize leaving no readily visible indication that it was the cause of the trip.

If you have experienced random, unexplained STARTER FAULT or NO TRANSITION problems on any of your MicroTech jobs, test and/or replace the HP relay.

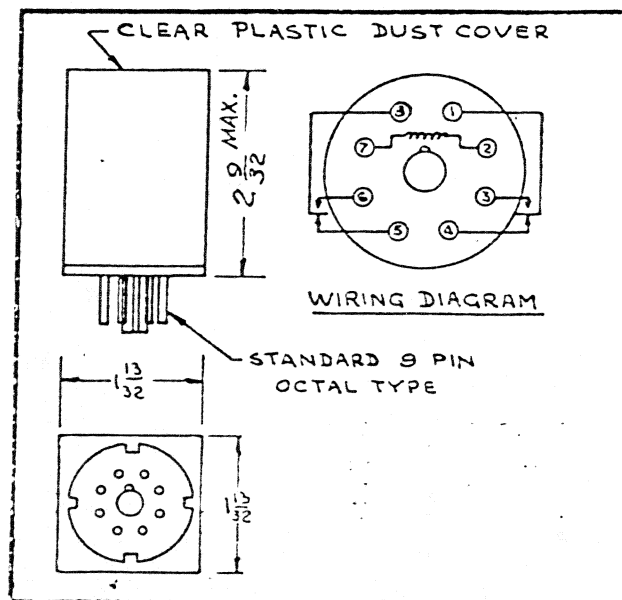

McQuay Service Bulletin

Air Conditioning

SB Number 20-9007-B
Code 20

Date 5/11/90
Originator SL

Page 1 of 1
Supersedes _____

MicroTech AC/DC Converter Board

The AC to DC converter board currently used in MicroTech chiller control panels is part number 492649B-01-B. A few control panels which contain this board may hang up during a routine shutdown and hold the oil pump on indefinitely while displaying the message "WAITING, HIGH AMPS". This condition will eventually cause oil pump failure.

A new, revised converter board is currently going into production in Staunton which includes several component changes to address this oil pump control problem. The new board is identified with part number 492649B-01-C.

If you experience this problem on one of your jobs, replace the existing converter board with the new style board. The new converter board must be re-calibrated for an output of 4VDC when the machine is running at 100% RLA.

Please note: You must specify REVISION-C when you place your parts order.

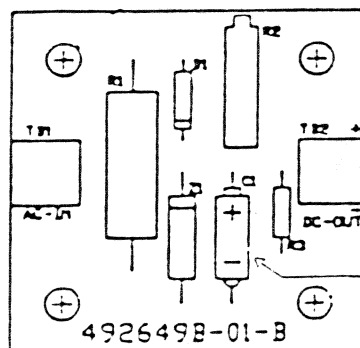

Revision C converter boards use a 330 ufd capacitor which replaces the 18 ufd capacitor found on the old revision B boards.

SB NUMBER 20-9208B

DATE 5/26/92

ORIGINATOR SL

CODE 20

SUPERSEDES _____

Low Oil Pressure Nuisance Trips

We have received reports of nuisance oil pressure trips on some recently shipped centrifugal chillers. The fault occurs primarily when an operating chiller is stopped by moving the front panel SW1 switch to the stop position. When the SW1 switch is opened, a transient voltage spike is developed on wires #503 & 504. In some cases, this voltage spike may cause a momentary drop in the 5VDC supply feeding the output board. This in turn will cause the oil pump contactor to drop out for 1 or 2 seconds which the MicroTech reads as a loss of oil pressure.

This wiring modification will be incorporated into new chillers during assembly at the Staunton VA facility. In the interim, all chillers shipped after December 1991 should be checked prior to initial startup to ensure this wiring change is in place.

This modification is mandatory on all chillers with daughter board serial numbers beginning with "AMI" regardless of ship date. The serial number is printed on a paper sticker affixed to the component side (front) of the circuit board.

The Fix:

Remove power from the panel by opening the circuit breaker.

Disconnect the red wires, #503 and #504, at the SW1 switch and pull them completely out of the spiralwrap wiring harness.

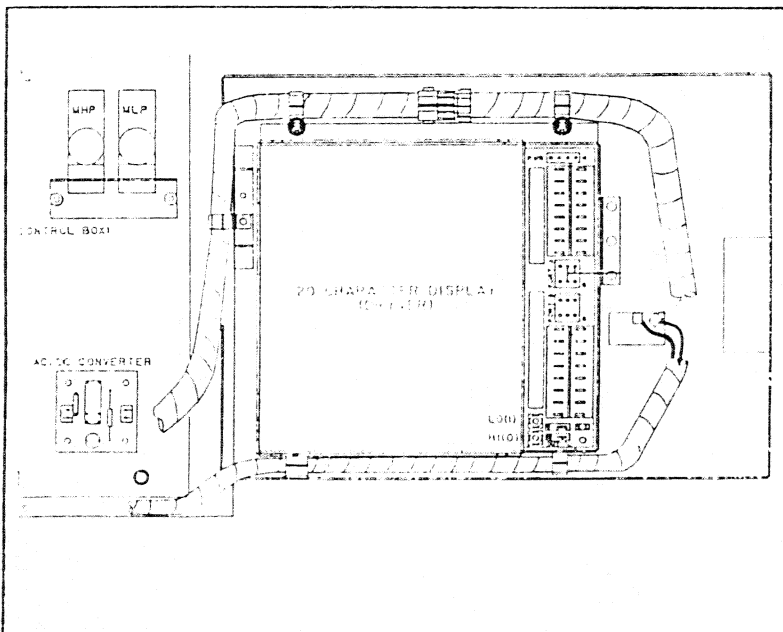

Correct Wire Routing.

Insert the wires into a new piece of spiralwrap and route the wires across the bottom of the display EnGinn and control cabinet. The new wiring harness should be secured along the bottom of the display EnGinn by using Ty-wraps attached to the EnGinn mounting screws.

Re-connect wires #503 & 504 to their original termination points on SW1.

Make sure the wires do not bind or become pinched when the panel door is closed.

Close the circuit breaker and test the control panel to ensure proper operation.

Data Fax

To: District Manager

From: Steve Lundquist

Company: McQuayService

Fax: (612)553-5422

Fax: _____

Page 1 of: 1

Date: June 15, 1992

RE: Wiring Harness

The spiral-wrap wiring harness material called out in service bulletin 20-9208 is available from Newark Electronics:

Mfgr	Part #	Material	List	Qty	Stock #
SPC Technology	HWN-04	1/4" nylon	\$31.85	100' roll	23N3650
Wieland	SP-1/4NN	1/4" nylon	\$31.85	100' roll	47F007

SnyderGeneral
Corporation

SB NUMBER 20-9209-B

DATE 7/24/92

ORIGINATOR SL

CODE 20

SUPERSEDES _____

Page 1 of 2

**MicroTech LLLB
Version DUA08D
Compressors won't load**

Some MicroTech LLLB panels will not allow compressor loading when both compressors are operating. This problem has been traced to an incorrect value stored at memory location \$8012 in the LLLB controller.

To verify the problem, connect your service computer to comm port A of the LLLB panel. Activate the McQuay Monitor program and establish network communication as a level 1 user.

Read the value at network address 00.00, memory location \$8012. The correct value for this location is 02. Controllers exhibiting the problem described above will have an incorrect value of 06.

If the value is correct:

No further correction to the LLLB panel is required.
See NOTE below.

If the value is incorrect:

Shut off both compressors by moving the MicroTech panel switches to the STOP position.

Write a new value of 02 to network address 00.00, memory location \$8012.

Read memory location \$8001. Subtract 4 from whatever value you find there and write that new value back to location \$8001.

Read memory location \$0204, the default value is 00.
Write a new value of 02 to this location.

Read memory locations \$8001-2. The values at both locations should match.

Restart the compressors by moving the MicroTech panel switches to the AUTO position and check the system for correct operation.

157242.SL

NOTE:

Fast vane speeds will cause a similar problem to the one described in this bulletin. In this case, the compressors will begin to load up but abruptly unload to minimum capacity after a minute or two. Setting the vane speed for not less than 1 minute from full open to full close should eliminate this condition.

SB NUMBER 20-9210-B

DATE 8/18/92

ORIGINATOR WGF

CODE 20

SUPERSEDES _____

Centrifugal MicroTech Output Board Fuses

Staunton Engineering has reported that our Solid State Output Board supplier has furnished some boards with one (1) amp fuses in some of the relay circuits.

These fuses should be rated at five (5) amps.

If, at or shortly following start-up, erratic operation is noted, test the fuse. A simple test procedure is described in paragraph 10 of the trouble analysis section of IM-403.

Correct fuses are SnyderGeneral Corporation part number 350A885H08, Littlefuse Company number 275-005 and 255005, or Bussman number 81F2110.

158172B.WGF

SB NUMBER 20-9211-B

DATE 10/1/92

ORIGINATOR SL

CODE 20

SUPERSEDES _____

We have received several reports of unexplained nuisance trips on centrifugal chillers installed after January of 1991. Some of the reported problems are:

- Incomplete start sequences. The chiller will shut down after the oil pump has run for 20 to 30 seconds.
- Moving the front panel SW1 switch causes all of the solid state relays to drop out for several seconds.
- Random, momentary shutoff of all solid state relays on the output board.
- Recurring oil pressure trips.

The cause of all of these problems has been traced to a change in the fabrication process employed by a couple of integrated circuit manufacturers that supply parts for McQuay daughter boards. This manufacturing change has resulted in centrifugal daughter boards with a high sensitivity to Electro-Magnetic Interference or EMI. If you encounter a centrifugal MicroTech panel that exhibits any of these symptoms, examine IC20 in the upper right area of the daughter board. Refer to Figure 1 for the exact location.

If the IC is a Motorola MC74HC4538N or National Semiconductor MM74HC4538N, additional troubleshooting will be required to isolate the problem. If the IC is a Motorola MC74HC4538AN or an RCA (Harris) CD74HC4538E, installing a McQuay 671147B-01 voltage regulator assembly should alleviate the problem.

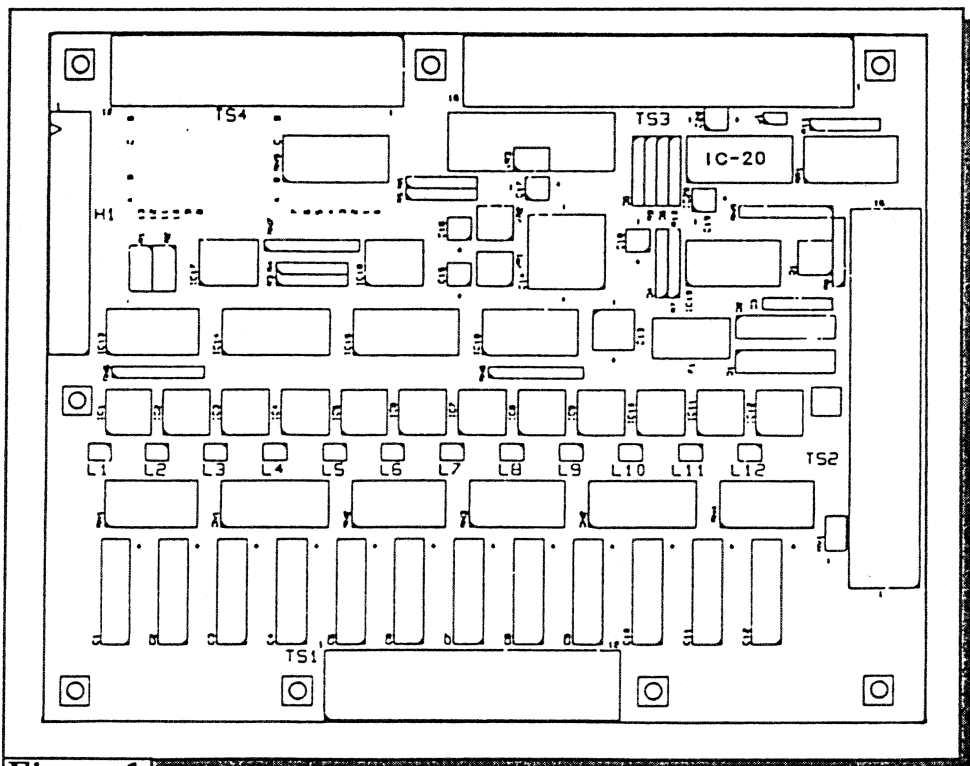

Figure 1.

INSTALLATION

Shut down the chiller and remove power from the MicroTech panel by opening the panel's circuit breaker.

Locate and disconnect wire #527 at terminal strip TS2-15 on the daughter board. Tie off and Insulate the wire so it will not come into contact with the cabinet or other electrical devices.

Locate and disconnect the other end of wire #527 at the + terminal on the output board. Tie off and Insulate the wire so it will not come into contact with the cabinet or other electrical devices.

Inspect the voltage regulator assembly for any breaks or tears in the shrink wrap cover. The circuit board should be completely insulated by the cover to prevent shorting out to the cabinet.

Refer to Figures 2 and 3 during the following procedure.

Attach the SHORT yellow lead of the voltage regulator assembly to the + terminal on the output board.

Attach the LONG yellow lead to the 17 VDC power supply at field wiring terminal 67.

Attach the LONG white lead to the DC supply ground reference at field wiring terminal 68.

Position the voltage regulator assembly so it will not become pinched in the panel door and dress the long yellow and white leads away from the door hinge.

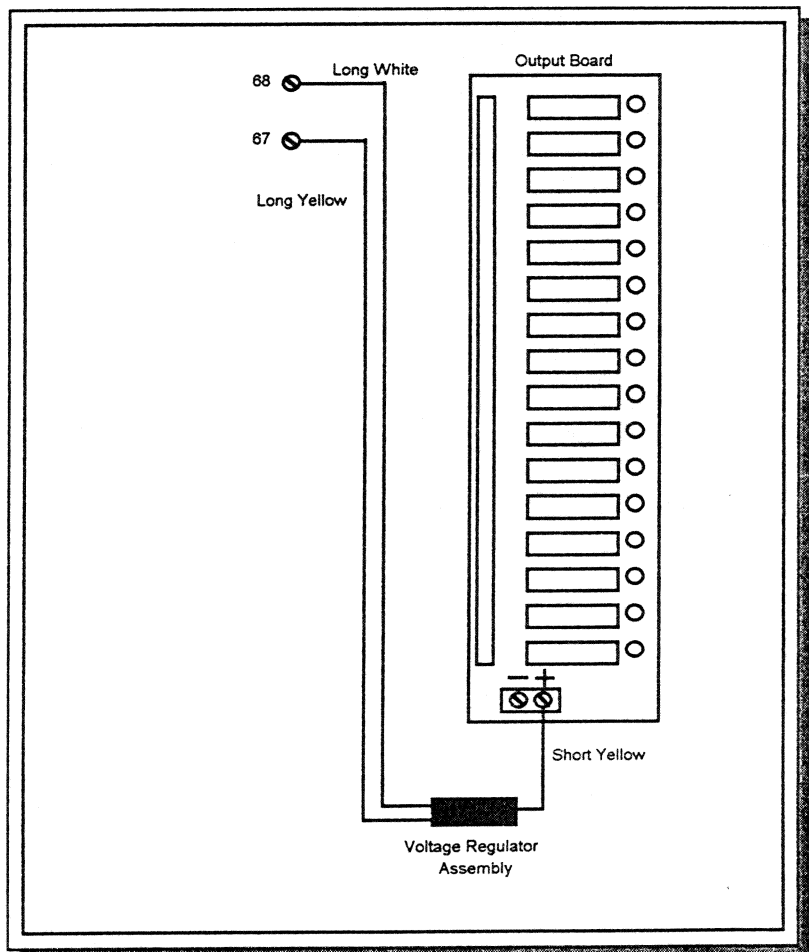

Figure 2.

TESTING

Apply power to the MicroTech panel by closing the circuit breaker. With a DC voltmeter, check for approximately 17 VDC across field wiring terminals 67 and 68. Check for 5VDC across the + and - terminals of the output board. Check the chiller carefully for proper operation.

It is normal for the voltage regulator assembly to generate some heat however, it should not become too warm to hold in your hand.

A schematic of the internal voltage regulator circuit is shown in Figure 3.

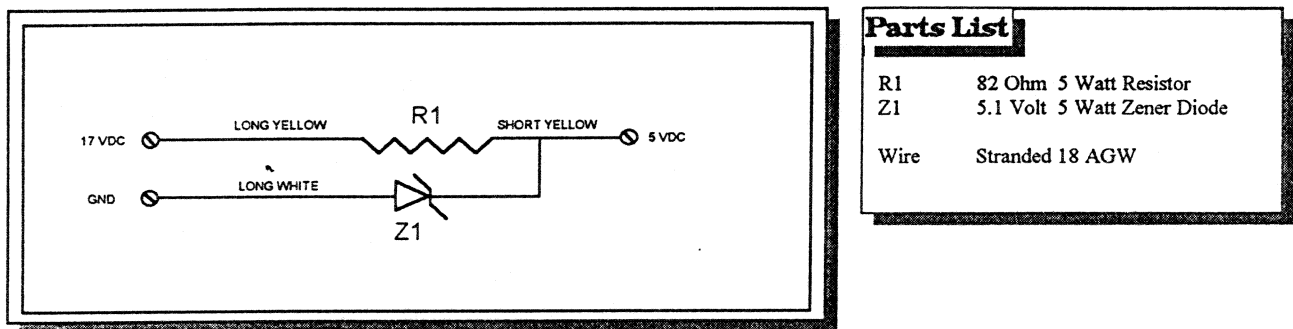

Figure 3

Parts List	
R1	82 Ohm 5 Watt Resistor
Z1	5.1 Volt 5 Watt Zener Diode
Wire	Stranded 18 AGW

SB NUMBER 20-9312

DATE 6/29/93

ORIGINATOR SL

CODE 20

SUPERSEDES _____

Page 1 of 4

REPLACEMENT FOR SERVICE BULLETIN 20-9312, DATED 2/4/93

MicroTech LLLB Panel Software Revision DUA09A

SnyderGeneral has issued a new software revision for centrifugal Lead / Lag - Load Balance panels which incorporates several new produce enhancements. These enhancements were developed in response to feedback from McQuayService technicians and are based on our experience with installed units in the field.

Revision DUA09A will be factory installed in all LLLB panels shipped after February 1, 1993. The new software may also be downloaded into existing panels if these new features would be of benefit to the customer. Check the Rep System Service Library or contact McQuayService, Minneapolis for a copy.

Please Note: DUA09A lead/lag load balance software is fully compatible with version 8 (or later) centrifugal chiller software. DUA09A software will only work in panels that utilize the MicroTech model 120 EnGinn. Older panels with the model 130 EnGinn (logic cartridge) will not operate properly with this revision.

1. Open Protocol Enhancement

Past Problem:

If the open protocol operating mode command transmitted by the temperature controls contractor was invalid (only values of 0 though 6 are valid) the LLLB panel would default to Chiller 1 Enabled, Chiller 2 Disabled (mode 6).

Solution:

The code was changed so that if the operating mode command is invalid, the LLLB panel operating mode becomes mode 2, Auto Lead and Lag.

2. Power Fail or Loss of Communications

Past Problem:

With previous software versions, if the LLLB panel loses communications to the lead chiller due to power failure, disconnected communication line, or any other reason, the lag chiller is disabled.

Solution:

The LLLB panel will now enable both chillers when communications is lost to one or both chillers. This will allow backup chiller operation if one of the unit's control panels has failed.

3. Lag Start Logic

Past Problem:

During the start sequence, the LLLB logic enables the lag chiller as soon as the lead chiller reaches 95% RLA for 5 minutes (default set points). The lag chiller then initiates a start procedure and the lead chiller is commanded to begin unloading. This has been a problem because the lag chiller may delay it's start due to Waiting For Load or Low Oil Temp. Meanwhile the lead chiller has fully unloaded and we are at risk of losing control of the cooling load. The solution to this problem differs depending upon the type of compressors being controlled: two PE's or one PF machine.

Solution for one PF chiller:

For dual compressor chillers, the lead compressor will only be unloaded when the lag compressor reaches the Oil Pump On mode. This means the lag compressor will run its oil pump for 60 seconds during which the lead compressor is unloading to reduce the lift pressure the lag compressor will have to start against. After the 60 second prelube time, the lag compressor proceeds to the Condenser Pump On mode for 15 seconds and then the MCR is energized.

Solution for two PE chillers:

For PE chillers, the lead chiller will not be unloaded until the lag chiller has fully started and has been in the Running OK mode for 120 seconds. This logic allows the lead chiller to maintain the cooling load while the lag chiller comes on line. The lag chiller will be allowed to partially load before the lead chiller begins load balancing which will result in better cooling load control.

The lag start logic requires that the LLLB panel know what type of system it is controlling. Currently the model 120 controller DIP Switches are set per I&M 425-2, page 7 which indicates that for analog input #8 the switches are all OFF. This is correct for software version DUA08D, however, the switch positions must be altered for version DUA09A and later. Refer to the attached drawing (page 4) for the correct switch settings.

4. Ice Storage Jobs

Past Problem:

McQuay's control strategy for ice storage jobs requires that the chillers run at 100% capacity (vanes wide open) while making ice. Load balancing is not desirable since it may cause a machine to unload in response to a capacity limit command which could generate compressor surge conditions.

Solution:

The LLLB panel now reads the chilled water setpoint out of the lead and lag chillers. If either setpoint is below 30°F, the load balancing logic is defeated. If both chilled water setpoints are greater than 30°F, normal load balancing is restored.

Since this logic will only work with chillers operating with special low temp chiller control software such as PC2L8A, some DIP switches must be set on the LLLB controller to identify the system as a low temp application. Currently, the model 120 controller DIP switches are set per I&M 425-2 page 7 which indicates that for analog input #7 the switches are all OFF. This is correct for software version DUA08D, however, the switch positions must be altered for version DUA09A and later. Refer to the attached drawing (page 4) for the correct switch settings.

Note:

This low temperature software logic is only appropriate for two separate PE single compressor units and **should not be used with dual compressor (PF) units**. Also, if the model 120 controller's DIP switches are set for one PF unit, the low temp logic will not be in effect.

LLLB Panel Switch Settings

Software Version DUA09A And Later

(Model 120 EnGinn Only)

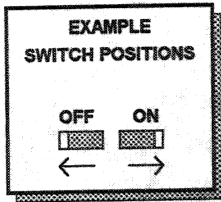
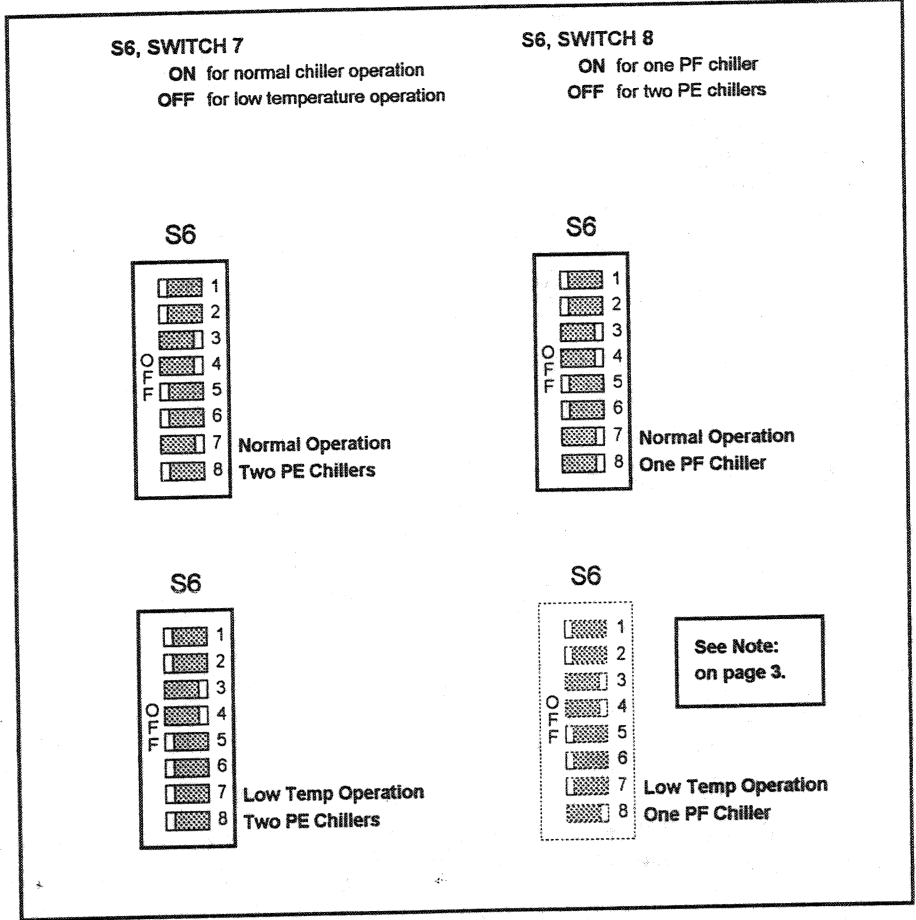
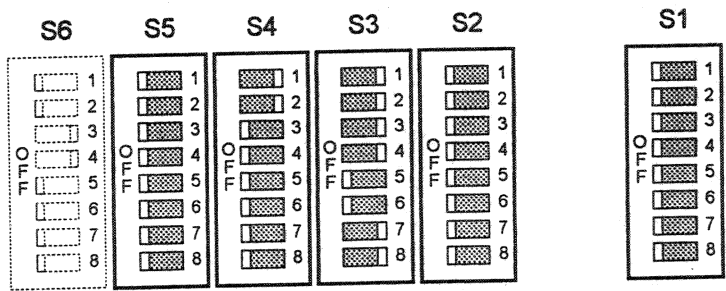

SB NUMBER 20-9313-SLDATE 2/5/93ORIGINATOR SLCODE 20

SUPERSEDES _____

Page 1 of 2

Centrifugal Chiller Display Failures
Preliminary Service Bulletin

A large number of centrifugal display EnGinns (model 180) assembled between August and October of 1992 were released to the field with incorrect display module mounting hardware installed. The resulting symptom is a loss of display although the chiller and keypad continue to operate properly. The display Enginns were supplied with the fluorescent display module mounted on metal standoffs secured with a Kepnut style (star) lockwasher and hexnut at each corner. The use of Kepnut lockwashers under the mounting nuts will cause traces on the circuit board to short to the metal mounting studs. Because the circuit board traces are coated with a thin layer of insulating material, the display failure may not occur until the chiller has been in operation for several weeks and panel vibration causes the lockwasher to work through the insulation.

All centrifugal display EnGinns currently in field parts inventory must be inspected for this problem and corrective action taken where necessary. Service calls on chillers with display problems should also include a check of the display mounting hardware. In either case, small diameter split lockwashers should be installed in place of the Kepnut washers at each corner of the circuit board to correct the problem. In most instances, the display module will not be damaged and does not need to be replaced.

This problem will not occur on display EnGinns utilizing plastic mounting studs.

15FE33.SCL

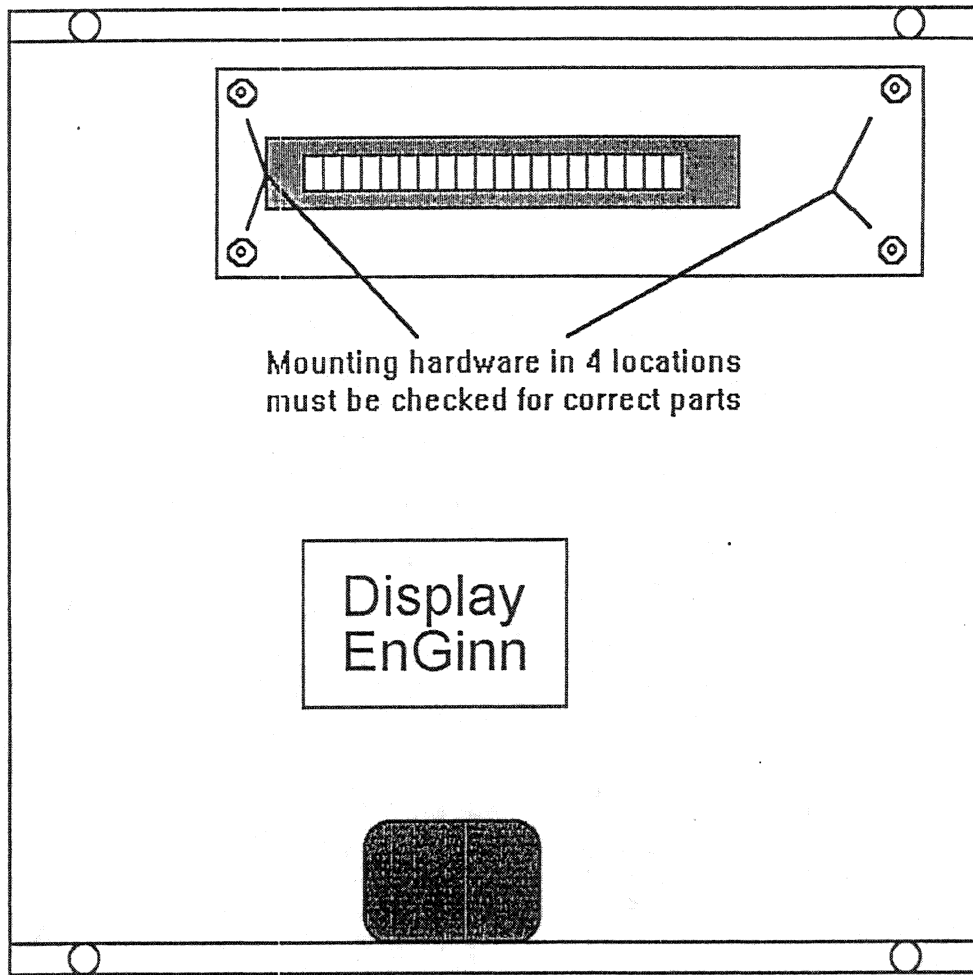

Mounting hardware in 4 locations
must be checked for correct parts

Display
EnGinn

Service Bulletin

SB Number: 20-9414-B
Originator: DOB
Supersedes:

Date: February 8, 1994
Code: 20

McQuayService
Page 1 of 2

Monitoring Multiple Units With A Single Modem

Occasionally it is necessary to be able to monitor multiple McQuay reciprocating or screw chillers with a single modem and phone line. In order to monitor multiple units with a single modem and phone line, one of the units needs to be re-configured to a level 1 controller or an RMS panel needs to be installed.

Following is a step by step procedure for changing a McQuay screw or reciprocating chiller control to a level 1 controller.

NOTE: This procedure assumes the technician is familiar with MicroTech monitor software and Hex based mathematical calculations.

1. Choose which unit will be the level 1 controller.
2. Set Hex switches of this unit to High = F, Low = F.
3. Cycle power to control using the control circuit breaker in the control panel.
4. Connect computer to port A of this unit and initialize communications with the level one password (for password information contact Minneapolis).
5. Go to Read/Write memory screen of monitor and change to box 00.FF.
6. Read memory locations 0A01-02 and record hex values (Check Sum). These two locations should contain the same number.

0A01 _____ 0A02 _____

7. Read memory location 0A05 and record hex value (# of Slaves). This value should be 00.

0A05 _____

8. Read memory location 0A11 and record hex value (Port Configuration). This value should be 29.

0A11 _____

9. Calculate new check sum

Note: the following calculations are all hex calculations. Hex numbers will be shown in **BOLD**.

NCS = new check sum

OCS = old check sum found in location 0A01 (This value may be different for every unit)

$NCS = OCS + (C1 - 0A11)$

If new value is a 3 digit number, drop the leading 1.

Typical calculation:

Note: The Hex number **EB** is being used for the old check sum in this calculation. This number will be different for each job.

$NCS = EB + (C1 - 29)$

$NCS = EB + (98)$

$NCS = 183$

New check sum = 83

10. Write C1 to memory location 0A11.
11. Write value equal to number of total units to be monitored minus one to memory location 0A05.
12. Write new calculated check sum to location 0A01.
13. Cut power to the control panel using the control circuit breaker in panel.
14. Set hex switches to Low=0, High=0
15. Connect communication wire between B ports of all units.
16. Set hex switches in second unit to Low=1, High=0. Third unit to Low=2, High=0 etc.
17. Connect modem to port A of any unit.
18. Re-energize controls of all units.
19. Connect computer to any open A port and re-establish communications with monitor.
20. Go to read/write memory and change to box 00.00
21. Read location 0A11. This value should be C1
22. Read locations 0A01 and 0A02. These two locations should both be the same as your new calculated check sum.
23. Check for proper communications with all units.
24. Go to remote phone line to test modem.
25. Configure monitor software.
26. Test monitor software.

Service Bulletin

SB Number: 20-9415-B
Originator: WGF/SL
Supersedes:

Date: April 26, 1994
Code: 20

McQuayService

Page 1 of 2

Electronic Wiring Connectors for MicroTech Panels

Electronic component wiring connections are noticeably different than connections used with conventional electric power or control wiring.

One device is now used for wire connections in most of our MicroTech panels. Wires are inserted into a receptacle called an "Insulation Displacement Connector" (IDC).

A special tool called a "Termination Tool" is used to press the wire into place.

Part numbers for the Termination Tool and of Insulation Displacement Connectors (IDC) follow along with a wire insertion procedure and illustration.

We recommend that service technicians have a tool and additional IDC's available.

McQuay Part#	AAF Part#	Vendor Part#	Description	List
671073A-14	----	AMP# 59804-1	Termination Tool	45.00
654999B-02	4EGA9159	AMP# 640433-2	Connector - PCB, 2 Circuit	.68
654999B-03	4EGA9160	AMP# 640433-3	Connector - PCB, 3 Circuit	1.00
654999B-04	4EGA9161	AMP# 640433-4	Connector - PCB, 4 Circuit	1.30
654999B-05	4EGA9162	AMP# 640433-5	Connector - PCB, 5 Circuit	1.60
654999B-06	4EGA9163	AMP# 640433-6	Connector - PCB, 6 Circuit	1.70
654999B-07	4EGA9164	AMP# 640433-7	Connector - PCB, 7 Circuit	2.00
654999B-08	4EGA9165	AMP# 640433-8	Connector - PCB, 8 Circuit	2.30
654999B-09	4EGA9166	AMP# 640433-9	Connector - PCB, 9 Circuit	2.60

Wire Insertion Procedure

1. Place the connector block on a flat surface or suitable support.
2. Position the insulated wire over the contact in the IDC connector. Make sure the end of the wire does not extend over the shoulder of the connector then set the wire onto the contact.
3. Place the termination tool on the wire over the contact so that the centerline of the tool matches the contact as shown in the illustration.
4. Hold the tool handle perpendicular to the contact and apply constant, direct pressure until the wire is terminated on the contact. Avoid excess pressure which can damage the contact.
5. Remove the tool and check that the wire is fully seated in the contact.

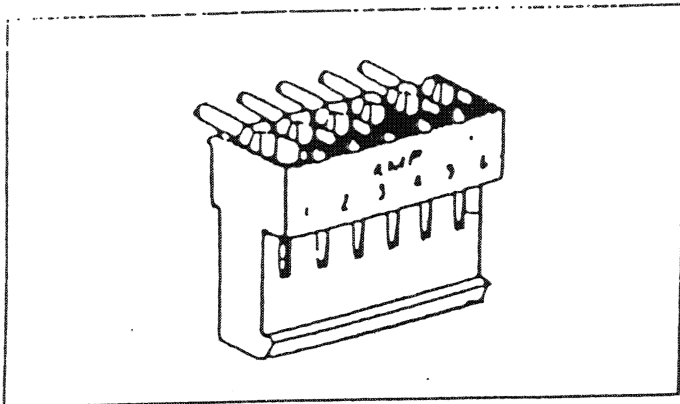

MTA-156 CLOSED-END RECEPTACLES-0.156" CENTERS, WITH LOCKING RAMP

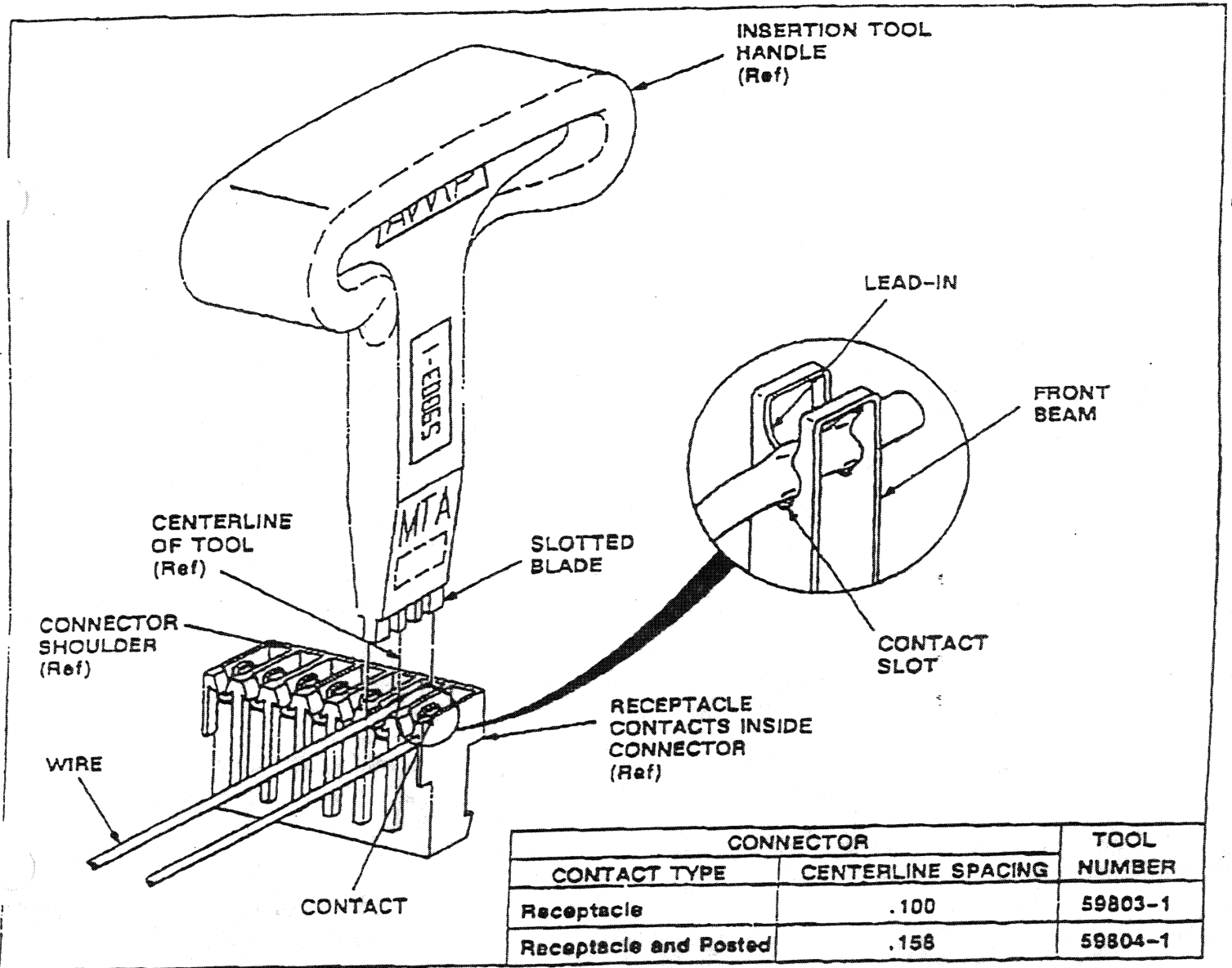

CONNECTOR		TOOL NUMBER
CONTACT TYPE	CENTERLINE SPACING	
Receptacle	.100	59803-1
Receptacle and Posted	.156	59804-1

McQuay

AAF

Wesper

yBlower

JennFan

Service Bulletin

SB Number: 20-9416-B

Originator: WGF

Supersedes:

Date: April 25, 1994

Code: 20

McQuayService

Lead-Lag Load Balance with MicroTech

Many of our field service technicians and sales engineers are combining refrigerant retrofit sales with electric control panel replacements, upgrading equipment to MicroTech control.

Where two (2) or more machines are load balanced using the original resistance type system, the quotation for MicroTech must include LLLB, or CPC panels if load balance will continue to be used.

The resistance type load balance cannot be used with MicroTech.

McQuay

AAF

...sper

...ryBlower

JennFan

Service Bulletin

SB Number: 20-9417-B
Originator: GWD
Supersedes:

Date: May 31, 1994
Code: 20

McQuayService

ROOFTOP MICROTECH SPACE SENSOR #2 - ERRONEOUS READINGS

Recently there have been some reports of erroneous temperature readings from rooftop space sensor P/N #665404B-02.

In September of 1993, Barber-Colman implemented a change which phased a new circuit board into the -02 space sensor. The board was the same one used in the 665404B-04 sensor. They failed to omit the R4 resistor from the board.

This introduces 6K ohms resistance between terminal 2 and 4 of the sensor. The added resistance is in parallel with the space sensor. This has the effect of adding about 15°F to the sensor reading.

To field fix a sensor, remove the sensor cover to expose the internal circuit board and clip the R4 resistor off the board.

The sensors with the problem are easy to identify from the labeling. On the box and on the back label of the sensor is a number TS-90410-702-0-1. The -1 is the added nomenclature that indicates the sensor has the revision which includes the incorrect board.

Sensors with date code of 94-10 (YY-WK) and later have been corrected.

SnyderGeneral
Corporation

Service Bulletin

SB Number: 20-9418-B
Originator: SCL
Supersedes:

Date: October 24, 1994
Code: 20

MicroTech Centrifugal Daughter Board

(478123C-01D)

The watchdog timer circuits have been omitted on all centrifugal daughter boards manufactured after May 5, 1994. The deleted components are IC19, IC20, and RR1 along with several resistors and capacitors formerly located in the upper right hand corner of the daughter board.

The timer circuits have been discontinued because some of the integrated circuits used for this portion of the board are no longer available from the vendor.

The watchdog timer circuit is a redundant safety which turns off all of the controller's outputs if the control software becomes corrupted. This safety feature is already built into the model 130 logic cartridge so there is no risk of damage to the chiller caused by the removal of the watchdog timer circuit.

There are no modifications necessary when replacing the daughter board. The new style board, identified by the part number 478123C-01E, is a direct replacement for the old style board.

The external 5 volt regulator described in Service Bulletin 20-9211-B is not needed with the new style daughter board.

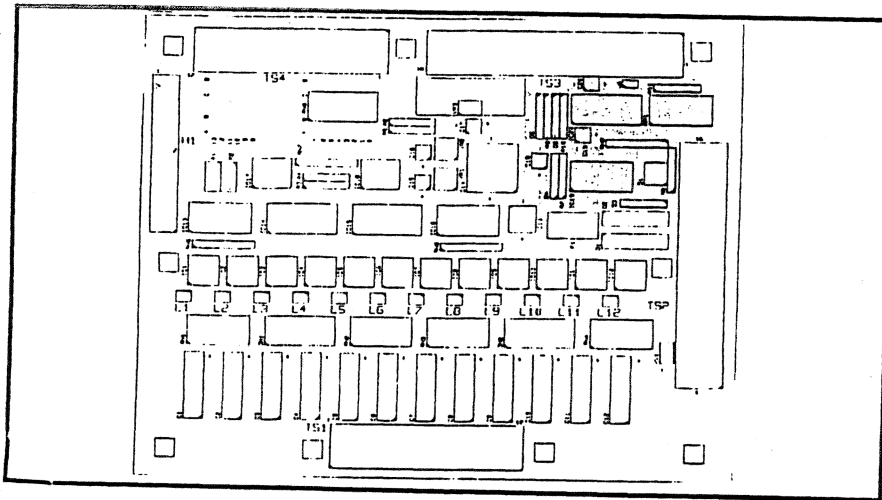

Service Bulletin

SB Number: 20-9519-B
Originator: SCL
Supersedes:

Date: February 23, 1995
Code: 20

Dry Running Centrifugal Starters 100-Series (old) MicroTech

During the initial startup of new centrifugal chillers it is desirable to "dry run" the starter and control panel with the motor leads disconnected. Since the compressor motor does not draw any current during this test, it is necessary to impress a false amperage signal on the motor current input of the MicroTech control panel.

In the past, this false amperage signal has been generated by simply disconnecting the wire attached to the positive side of the signal converter board's DC output terminals. Electrical components mounted on the daughter board would then provide a positive bias which the logic cartridge interprets as approximately 40% to 50% RLA.

This technique no longer works due to component changes on the latest version of centrifugal daughter boards. With the new daughter boards, an externally supplied bias voltage is required to generate a false amperage signal. The proper technique to dry run a starter with an old style MicroTech panel is as follows.

- Disconnect and tape off the motor leads at the starter or motor terminals.
- Disconnect both wires at the signal converter board's DC output terminals. (note polarity)
- Temporarily connect a 1.5V battery across the two wires.
- Perform the dry run test.
- Remove the 1.5V battery and reconnect the wires to the signal converter board's DC output terminals. (note polarity)
- Reconnect the motor leads in the correct phase order to ensure correct rotation.

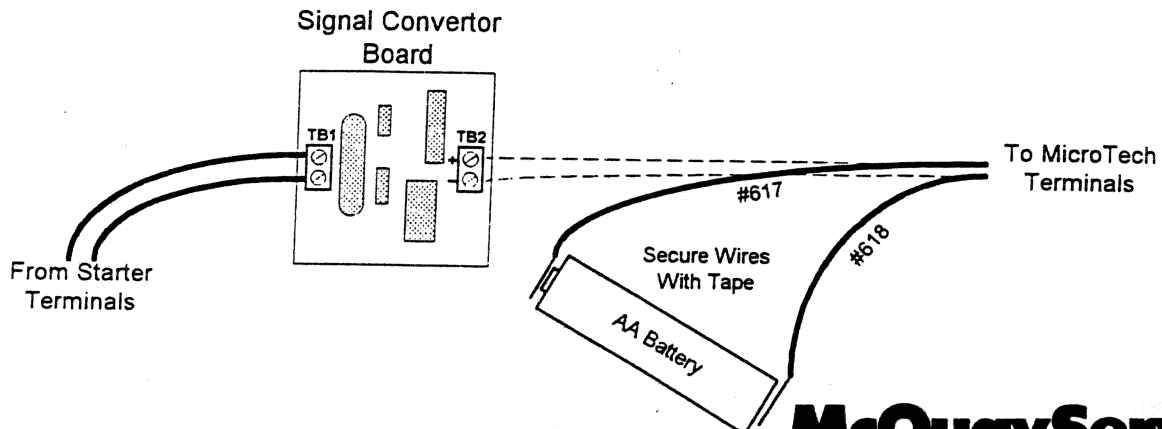

McQuay

AAF

per

BarryBlower

JennFan

Service Bulletin

SB Number: 20-9520-B

Originator: SL

Supersedes:

Date: April 18, 1995

Code: 20

McQuayService

Series 200 Centrifugal MicroTech Panel

A minor problem has been discovered in early versions of the control software used in Series 200 centrifugal MicroTech panels. We have found that some of the solid state relay outputs do not respond properly to manual commands issued while the controller is in the Service Test mode (menu 25).

While there is no risk of equipment damage, the following software versions should be updated to prevent possible misinterpretation of Service Test results.

- 50732010 134a, English Units
- 50734010 R12, English Units
- 50733010 134a, SI Units
- 50735010 R12, SI Units

The software identification (ident) may be viewed on the chiller's keypad/display under menu 26, Unit Setup. If an update is required, the most current software version can be downloaded from the McQuayService Library in Minneapolis. 1-800-553-0445.

SnyderGeneral
Corporation

McQuay
AAF
Wesper
QuayService
JennFan
BarryBlower

Service Bulletin

SB Number: 20-9521-B
Originator: JW
Supersedes:

Date: June 8, 1995
Code: 20

CNS Standard - 201, "Network Architecture"

This standard supersedes Service Bulletin 20-9414-B, dated February 8, 1994, "Monitoring Multiple Units with a Single Modem."

The following standard describes the detail for all network architecture. Both sales representatives and McQuay Service representatives should follow this standard when discussing MicroTech unit controller configuration for communications purposes with customers and representatives, either verbally or in writing.

A basic understanding of network architecture is needed to understand this standard:

The network architecture has three levels. Communications occur between level-one and level-two controllers, or level-two and level-three controllers. There is no direct link between a level-one and a level-three controller. **Master** and **Slave** are designations for network connections. The level-one controller is always a **Master**. There can only be one **Master** in a level-one to level-two, or a level-two to level-three wiring trunk. The **Master** initiates communications requests to its connected **Slaves** and processes responses to allow all controllers in the network to communicate with each other. Therefore, it only requires a single entry point into the network to communicate with each controller. Since each controller has two communications ports, any ports not used for network communications can be designated as **TTY**. **TTY** is a port designation that allows communications through a PC, either by direct connection or through a modem using Monitor software, or for connection by an Open Protocol partner.

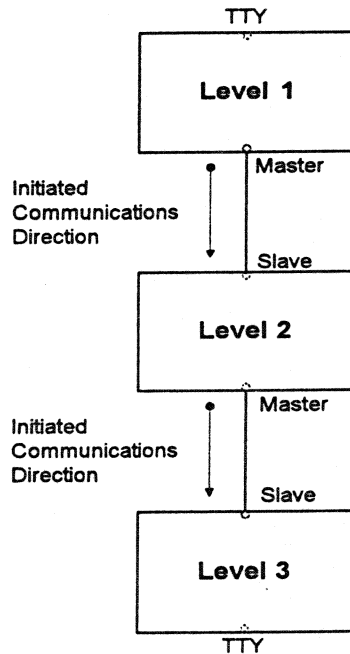

The goals of a network architecture standard are as follows:

1. To provide a common and unchanging architecture for interconnecting MicroTech controllers for communications purposes.
2. To avoid using a unit controller for handling network control and communications functions.
3. To clear congestion of the Level-One/Level-Two communications bus as much as possible, for communication with our BAS partner's gateways.

To accomplish these goals the following is the acceptable configuration for all unit controllers:

Unit Controller	Level	Port A	Port B
Single Centrifugal w/o LLLB (200 series)	L2	TTY	Slave
Single/Dual Centrifugal (200 series master)	L2	Master	Slave
Single/Dual Centrifugal (200 series slave)	L3	TTY	Slave
Centrifugal Chiller Power/Logic (100 series)	L3	TTY	Slave
Centrifugal Chiller Display (100 series)	L2	Master	Slave
Reciprocating Chiller	L2	TTY	Slave
Screw Chiller	L2	TTY	Slave
Rooftop	L2	TTY	Slave
Air Handler	L2	TTY	Slave
Self-contained AC	L2	TTY	Slave
Unit Ventilator (Stand Alone/Open Protocol)	L2	TTY	Slave
Unit Ventilator (MicroTech Network)	L3	TTY	Slave
WSHP (Stand Alone/Open Protocol)	L2	TTY	Slave
WSHP (MicroTech Network)	L3	TTY	Slave

A level-two unit controller should not be converted to a level-one controller to allow the networking of multiple level-two unit controllers for the purpose of communication. All network functions are lost if the converted unit is down for servicing and/or maintenance. In all cases, **networking multiple level-two unit controllers, requires a dedicated level-one network control panel** such as a RMC, RMS, CSC, etc., or an Open Protocol Master (OPM) panel. The OPM is factory configured at Level-One (Port A = TTY, Port B = Master).

A **dual centrifugal chiller is considered to be two unit controllers** for the purposes of the network architecture standard.

Currently the only standard architecture structure supporting multiple unit controllers that would provide an open TTY port is the dual chiller configuration or a two single chiller w/LLLB function configuration. In each of these cases, **where a single TTY connection is required**, it is acceptable to use the open TTY port from the level-three controller as an Open Protocol connection point, a direct connection, or a modem connection. In the case where two TTY ports are required, one for Open Protocol, one a direct or modem connection, an OPM panel or other level-one network control panel is required as explained above.

Service Bulletin

SB Number: 20-9522-B
Originator: DLH
Supersedes:

Date: August 30, 1995
Code: 20

Series 200 MicroTech PF Units or Dual PE Units With Lead Lag Configuration

Some information was inadvertently left out of IM 616 (200 Series MicroTech Control Panel) concerning network connections and menu settings. The following procedure provides the necessary information to network two series 200 MicroTech controls in the lead/lag configuration.

1. Select which MicroTech will be configured as the master and perform steps 2 through 7.
2. Remove plug in port A and disconnect from terminal strip.
3. Remove plug in port B and plug into port A.
4. Set Hex address hi=0, low=1.
5. Menu 11 [Control Mode]
 - a. Select (Auto:Network)
6. Menu 26 [Unit Setup]
 - a. Screen 1 Line 1 (Configure=L2-Mastr-Slv)
 - b. Screen 2 Line 1 (Master/Slave=Master)
7. Menu 23 [Lead Lag Setup]
 - a. Screen 1 Line 1 (Slave Address=01)
 - b. Screen 1 Line 1 Item 2 (Start-up=Unload)
8. Go to Slave MicroTech and perform steps 9 through 12.
9. Set Hex address hi=0, low=1.
10. Menu 11 [Control Mode]
 - a. Select (Auto:Network)
11. Menu 26 [Unit Setup]
 - a. Screen 1 Line 1 (Config=L3-TTY-Slave)
 - b. Screen 2 Line 1 (Master/Slave=Slave)
12. Menu 23 "Not available on slave MicroTech"
13. All other settings must be the same as Master and Slave MicroTech.

McQuay
AAF
Wesper
McQuayService
JennFan
BarryBlower

Service Bulletin

SB Number: 20-9623-B
Originator: David Hale
Supersedes:

Date: March 21, 1996
Code: 20

200 Series MicroTech Starting Alarms/Faults

Centrifugal units located in a heated or poorly ventilated mechanical room may experience starting alarms/faults that read:

- High Suction Superheat
- High Discharge Superheat at Min RLA
- High Discharge Superheat at Max RLA
- Surge-High Suction Superheat - Starting
- Surge-High Suction Superheat - Running

All the above could be caused from overheating caused by the gear case heater. The suction sensor is reading the suction line temperature during stopped conditions, thus providing input to the MicroTech. The MicroTech interprets this as an alarm condition at start-up and can shut the compressor down if the suction line temperature remains high. Resetting timing functions or increasing the values in menu 22 will not eliminate these alarms/faults.

This condition can be eliminated by installing a thermostat (Johnson Controls A19ABC-4 or equivalent) to control the gear case heater. The A19 thermostat can be mounted on the exterior of our control panel and the bulb fastened to the compressor gear case with epoxy. (See Wiring Diagram #0718533D on the control panel door.) The heater should be wired to the A19 Terminals R & B (NC normally closed contacts), and set to open at 85°F. Wire from MicroTech terminal 31 to the Johnson Controls A19 Terminal R, and from the Johnson Controls A19 terminal B to the gear case heater.

Service Bulletin

SB Number: 20-9624-B
Originator: David Hale
Supersedes:

Date: August 26, 1996
Code: 20

Page 1 of 6

PFS A vintage with remote air cooled condenser.

There have been several special PFS units constructed that have remote air cooled condensers instead of water cooled condensers. The compressor heaters on the remote air cooled condensers were wired in two different configurations. One was to have the MicroTech control the compressor heaters. The other was to wire the heaters through the auxiliary contacts of the compressor contactor. Problems occurred from both configurations.

The software (SC22U19D.COD) was modified to control the heaters according to measured suction line temperature vs. saturated evaporator temperature (superheat). The heaters will be energized when the compressor is in the off state and the superheat calculated is below 3°F (see attachments for specific operation).

The modified software requires a wiring change and the addition of solid state relays per the attached drawings. Menu 24, Misc Setup, has an additional screen (#3) which allows the selection of the type of condenser. The default value is local and should be set to remote. The unit type still has to be set to the ALS selection to allow control of the condenser fans. The settings will indicate and ALS unit with remote condenser. These settings will allow the unit to control the condenser fans and to control the compressor heaters to regulate the suction superheat during the compressor off cycle.

This software does not compensate for the wait flooded condition and can be install in all units without compliant gates. The wait flooded condition arising from a low suction superheat should be eliminated through control of the compressor heaters.

Contact McQuay Technical Support for software.

1. Description of Software

This software is used to control the Frame 2, Screw compressor (two compressors). The controller is a Model (280-50) manufactured by (EnergyLine). The controller part number is (0654873B-50-A).

2. Description of Modification (Version U19D)

Changed the Refrig=field, on menu 24 of the keypad, to accommodate all the refrigerant types. It was set up with only R22 and R134a labels. This was not working correctly, so the other three labels were added in their proper places. (R12, R114, and R500). Added a set-point to identify if the unit is remote air cooled. Also, for remote cooled units, two digital outputs were added at output 22 and 23. These outputs are called RemoteCompHeater1Out and RemoteCompHeater2Out. The heater operates only when the compressor is off. When the compressor is shut down, the heater is turned on and a timer is set to zero. This timer then counts up to 15 (1 count per minute). This means that the heater will stay on for 15 minutes, after the compressor turns off, no matter what. After the initial 15 minutes has passed, the controller begins to look at the superheat. The timer continues to count up 1 count per minute. If the superheat exceeds 8°F, at any time, the heater is turned off. Also if the superheat exceeds 3°F and the timer value is greater than 120, the heater turns off. As long as the compressor is turned off, the heater will remain on if the superheat stays below 3°F. There is no limit to the length of time it will remain on if the superheat stays below this limit and the compressor remains in the off state. If the heater is in the off state and the superheat falls below 3°F, the heater is turned on and the timer is given the value 105 (minutes). The timer continues to count up 1 count per minute. If the superheat exceeds 8°F, at any time, the heater is turned off. Also, if the superheat exceeds 3°F and the timer value is greater than 120, the heater turns off.

- If replacing sc22u19a.cod or sc23u19a.cod, you can save the following:

Passwords	Network	Setpoints	Control	Tables	All
X	X		X		

- If replacing sc22u19b.cod or sc23u19b.cod, you can save the following:

Passwords	Network	Setpoints	Control	Tables	All
X	X		X		

If replacing sc22u19c.cod or sc23u19c.cod, you can save the following:

Passwords	Network	Setpoints	Control	Tables	All
X	X		X		

- The software will work with older versions of Monitor, but the new setpoint will not fill in.
- This software does require high memory.

MODELS: PFS 140A-200A W/REMOTE CONDENSER
8 STAGE OUTPUT SCHEMATIC Software SC22419D.COD
SEE LEGEND 719833C-01

120VAC/60/1 FROM UNIT CTRL. SCHEM.

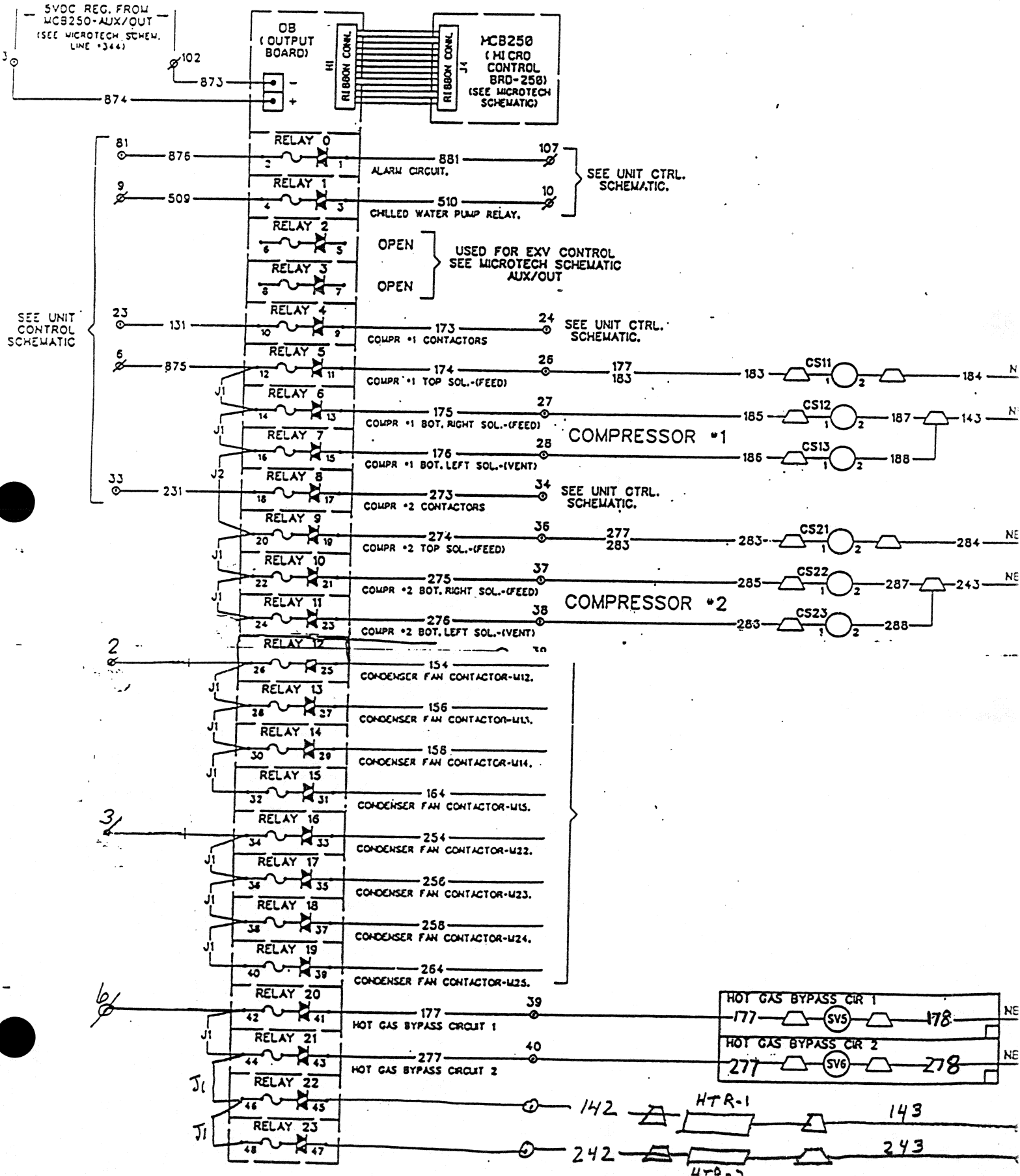

MODELS: PFS 140A-200A
8 STAGE OUTPUT SCHEMATIC
SEE LEGEND 719833C-01

120VAC/60/1 FROM UNIT CTRL. SCHEM.

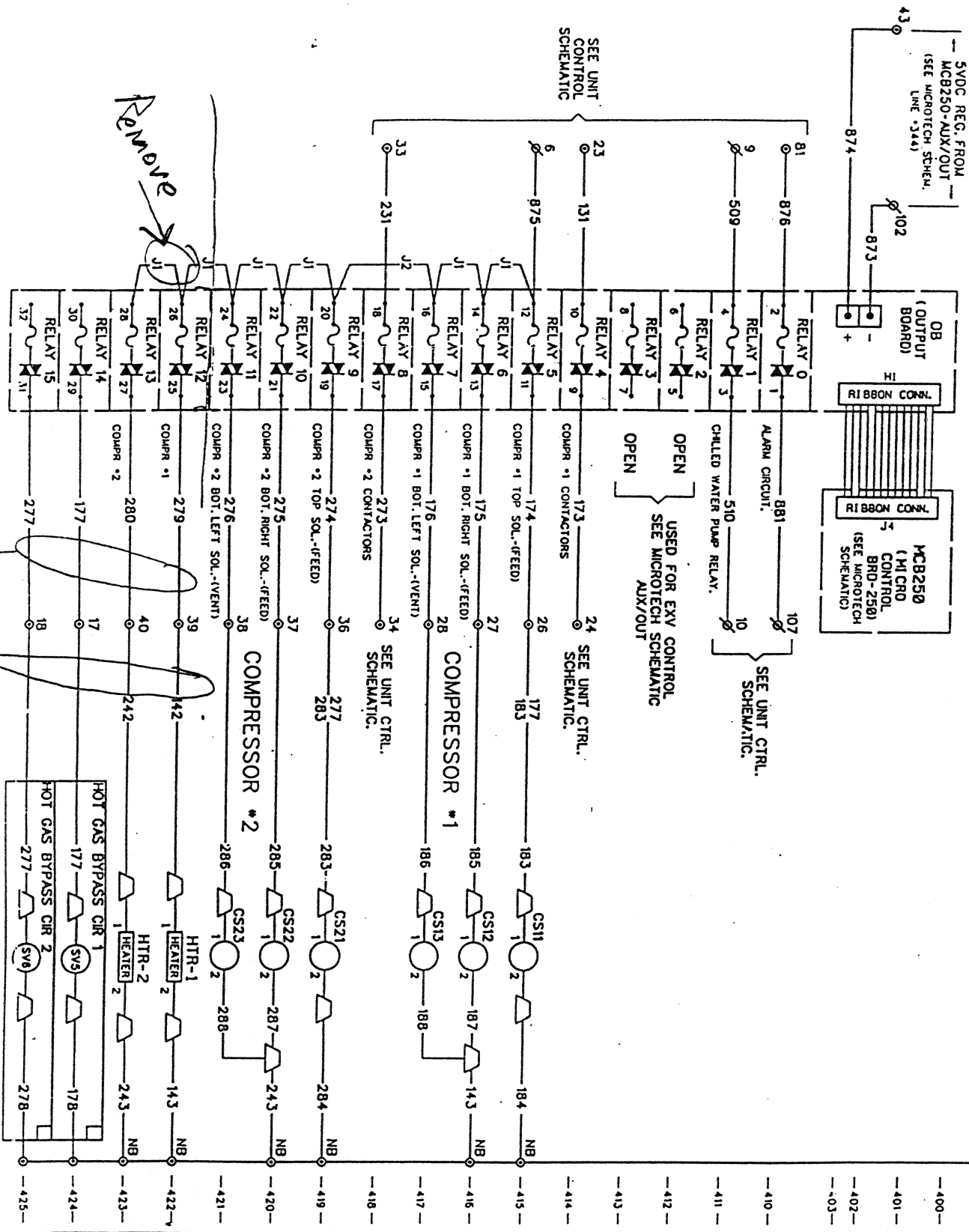

LINE NO.	CONT. NO.	TERMINAL BLOCK & LEAD NUMBERS
400		17 177,178
401		18 277,278
402		19
403		20
404		21
405		22
406		23 131
407		24 173
408		25
409		26 174,183,177
410		27 175,185
411		28 176,186
412		29
413		30
414		31
415		32
416		33 231
417		34 273
418		35
419		36 274,283,277
420		37 275,285
421		38 276,286
422		39 142,279
423		40 242,280

SEE UNIT CTRL. SCHEM. FOR COMPLETE TERMINAL NO. LIST FOR (182)

TB2

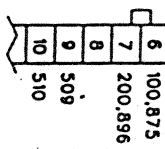

TB3

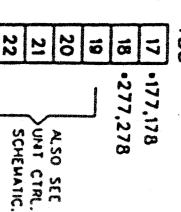

TB4

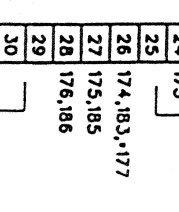

TB5

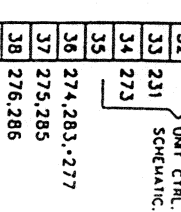

TB6

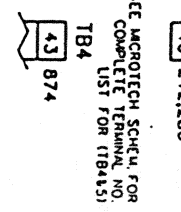

TB7

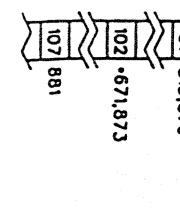

NB - (BOTTOM ROW)

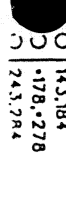

SEE MICROTECH SCHEM. FOR COMPLETE TERMINAL NO. LIST FOR (184/15)

REMOVE

REMOVE

SEE UNIT CONTROL SCHEMATIC

USED FOR EXV CONTROL SEE MICROTECH SCHEMATIC

SEE UNIT CTRL. SCHEMATIC.

5VDC REG. FROM MCB250-AUX/OUT (SEE MICROTECH SCHEM. LINE #344)

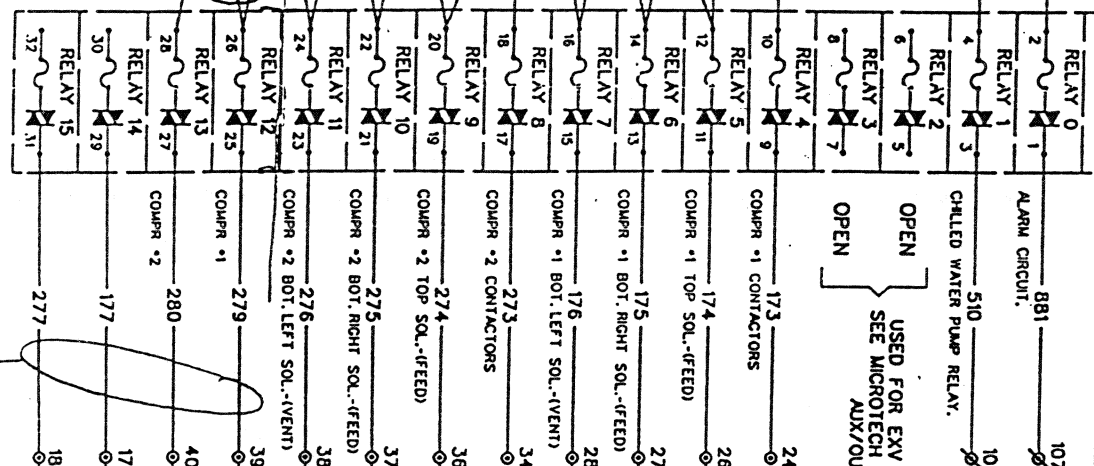
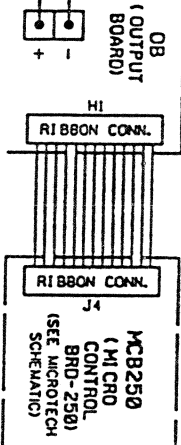

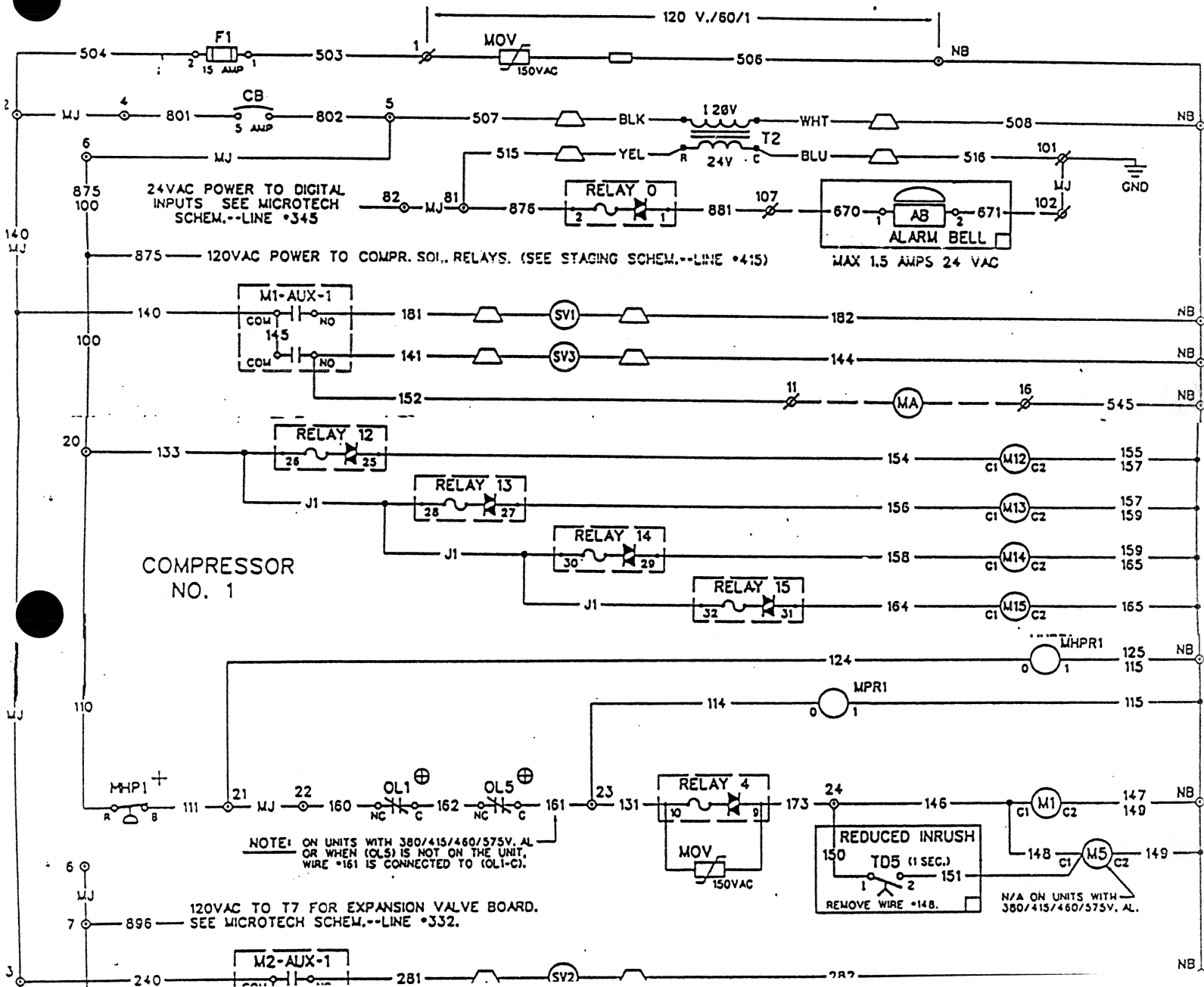

McQuay
AAF
Wesper
McQuayService
JennFan
BarryBlower

Service Bulletin

SB Number: 20-9625-B
Originator: DLH
Supersedes:

Date: August 26, 1996
Code: 20

Page 1 of 9

AOX-4 Board Installation

The optional AOX-4 board does not have adequate installation instructions when ordered from McQuayService parts. The operational parameters are covered in OM 125 (200 Series MicroTech Control Panel) menus 19 and 20.

The replacement parts list number 057107900 (Series 200 MicroTech Control System for Centrifugal Chillers) page 8 lists the components needed. They are as follows:

1 each	AOX control board	066794840
1 each	Circuit board mount	557272A-03
1 each	Ribbon cable	654997B-01
2 each	Screw	389908A-03

There is adequate space in the control cabinet directly above the MicroTech Controller for installation. The ribbon cable connects to the MicroTech controller at the top and is the only connector available. The ribbon cable connects to the J1 pin on the AOX-4 board. The J7 connector on the AOX-4 board will accept the ribbon connector, however, the AOX-4 board will not communicate if installed in this connector. The power wiring is connected to terminals 97 (ground) and 98 (12-18 Vdc.) Conform to polarity markings on the AOX-4 board.

There are four (4) analog outputs on the AOX-4 board. The first output is zero (0) and is located next to J7 connector. Directly above the output connector is the shorting pins that allows the type of analog output to be selected. The options are 0-5 Vdc, 0-10 Vdc, 0-5 mA, and 0-20 mA. See the attached for pin orientations.

When the mA signal is used, the wiring connection must be the floating ground type. Do not ground our signal to the user common. The Vdc signal are common grounded to the user common. (See attached sheets).

ENERGYLINE PRODUCT SPECIFICATIONS

ANALOG OUTPUT EXPANSION (AOX) BOARD

DESCRIPTION

The Analog Output Expansion Board converts TTL output control signals from Model 280 EnGinn™ controller units to two different current and voltage ranges suitable for input to various actuators. The ranges of current, 0-5 mA and 0-20 mA, and voltage, 0-5V DC and 0-10V DC, are user selectable. Two versions of the Analog Output Expansion board are available: AOX-4 and AOX-2. (see attached figures) The AOX-4 offers 4 channels of output per board and may be daisy chained with two other Analog Output Expansion boards and a Model 280 EnGinn™ Controller resulting in a maximum of twelve analog outputs. The AOX-2 interfaces only with the Model 280 EnGinn™ Controller, offers two channels of analog output, and cannot be daisy chained. The AOX-4 can also be daisy chained with a Digital Input Output Expansion board, a Model 280 EnGinn™ Controller, and two other AOX boards. For more information contact Tom Webster, Director, Industrial Products Group, EnergyLine Systems, Inc., 2065 Kittredge Street, Suite A, Berkeley, CA 94704.

POWER REQUIREMENTS

10-20 VDC unregulated or 16-24 VAC.

(If any analog outputs are set to 0-10 V, increase unregulated dc power input to 10.5 volts minimum)

ANALOG OUTPUTS

User Selectable Ranges

Voltage	Current
0-5 VDC	0-5mA
0-10 VDC	0-20mA

Allowable Input Impedances for driven devices

Output Ranges	0-10.5 V power input	20 V power input
0-10 VDC	700 Ohms minimum	700 Ohms minimum
0-5 VDC	350 Ohms minimum	350 Ohms minimum
0-5 mA	1000 Ohms maximum	3000 Ohms maximum
0-20 mA	250 Ohms maximum	750 Ohms maximum

1

 Industrial Products Group
2065 Kittredge Street, Suite A
Berkeley, CA 94704
Tel (510)644-8182 Fax (510)644-2058

© Copyright 1991-1993 EnergyLine Systems
All Rights Reserved.

1.3 ANALOG OUTPUTS - SETUP AND WIRING

The AOX board (AOX-4 and AOX-2) can output the current and voltage signals given in Table 1-1. To select an analog output range on either board version, the user simply shorts the appropriate header pins with a jumper. Figure 1-4 shows the jumpered configurations that represent all possible outputs of the board. All analog output channels are independent of one another. For example, it is possible to select the 0-5 V range as one output, 0-10 V as the next output, 0-5 mA as another output, and 0-20 mA as the final output on a single board. On a power reset, the analog outputs are set to 0 volts or 0 milliamps depending upon the output signal setting.

Voltage	Current
0-5 VDC	0-5mA
0-10 VDC	0-20mA

Table 1-1 User Selectable Ranges

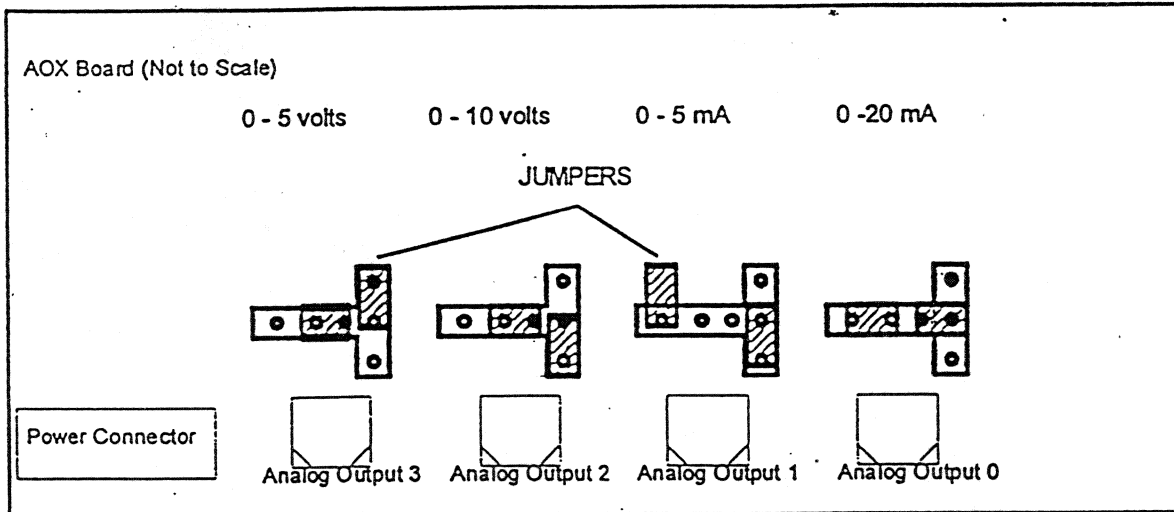

Fig. 1-4 Jumper Placement for Analog Output Generation

SECTION 1 - SYSTEM DESCRIPTION

PAG-AOX

An important consideration in using the analog outputs is to insure that the input impedances of the devices to be connected to the analog outputs are within the ranges given below in Table 1-2. The input impedances of the driven devices are dependent upon the power input to the AOX board and are given for two DC voltage inputs to the board in Table 1-2. If the power input to the AOX board is between 10.5 V and 20 V, the maximum impedances of the driven devices for either 0-5 mA or 0-20 mA ranges are found by linear interpolation.

Analog output ranges	10.5 V power input	20 V power input
0-10 VDC	700 Ohms minimum	700 Ohms minimum
0-5 VDC	350 Ohms minimum	350 Ohms minimum
0-5 mA	1000 Ohms maximum	3000 Ohms maximum
0-20 mA	250 Ohms maximum	750 Ohms maximum

Table 1-2 Allowable Input Impedances

WARNING:

Never output a current to an actuator which has a grounded current return line. A current signal can only be sent to an actuator that has floating input and return current lines. If an actuator has its current lines grounded, a voltage signal should be used instead. See Figures 1-5, 1-6, and 1-7. The voltage level can be determined by multiplying the desired input current and the internal resistance of the actuator. For example, using Ohm's Law and knowing that the actuator requires 20 mA and that the internal resistance of the actuator is 500 ohms, the input voltage should be: $.020 \text{ amps} \times 500 \text{ ohms} = 10 \text{ volts}$.

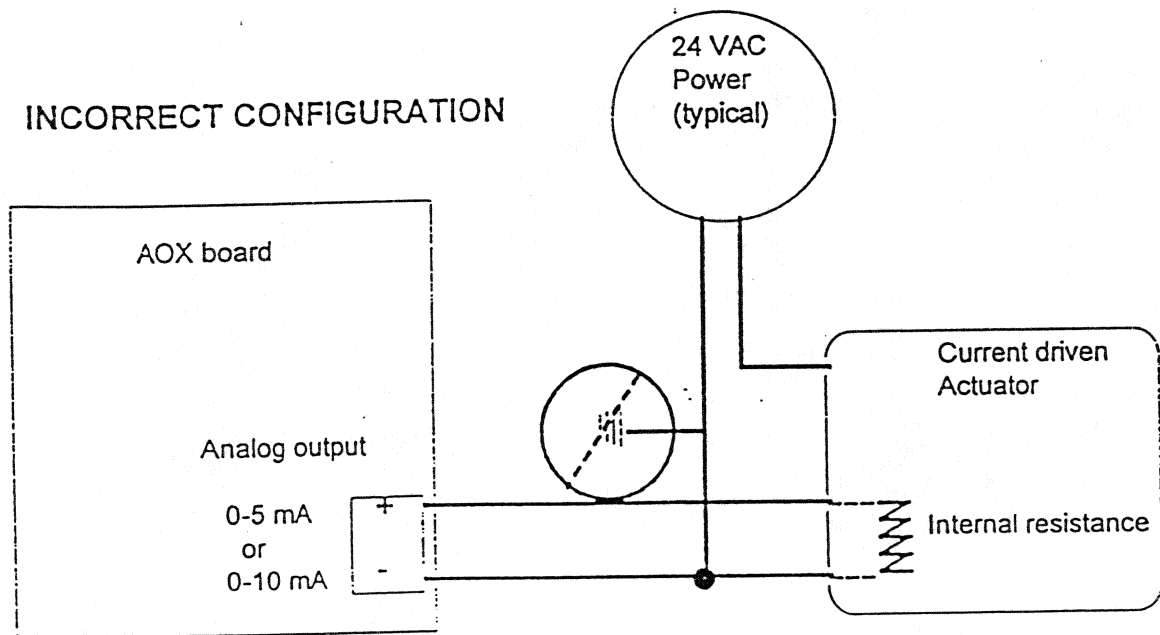

Fig. 1-5 Incorrect Configuration for Current Mode (current return line is grounded)

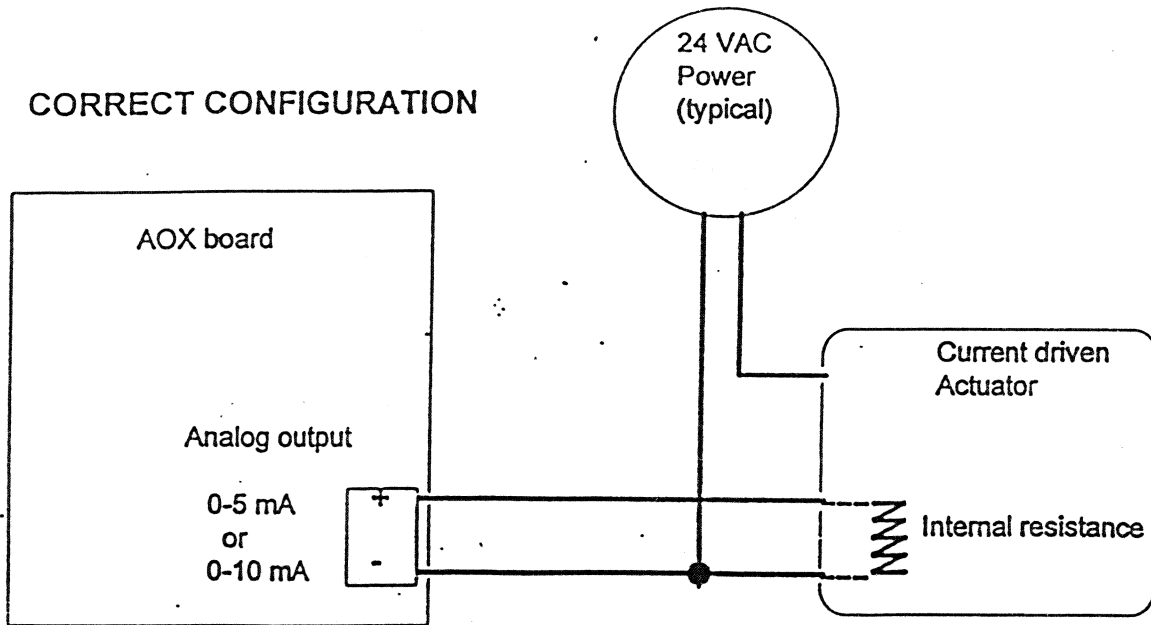

Fig. 1-6 Correct Configuration for Current Mode (neither current line grounded)

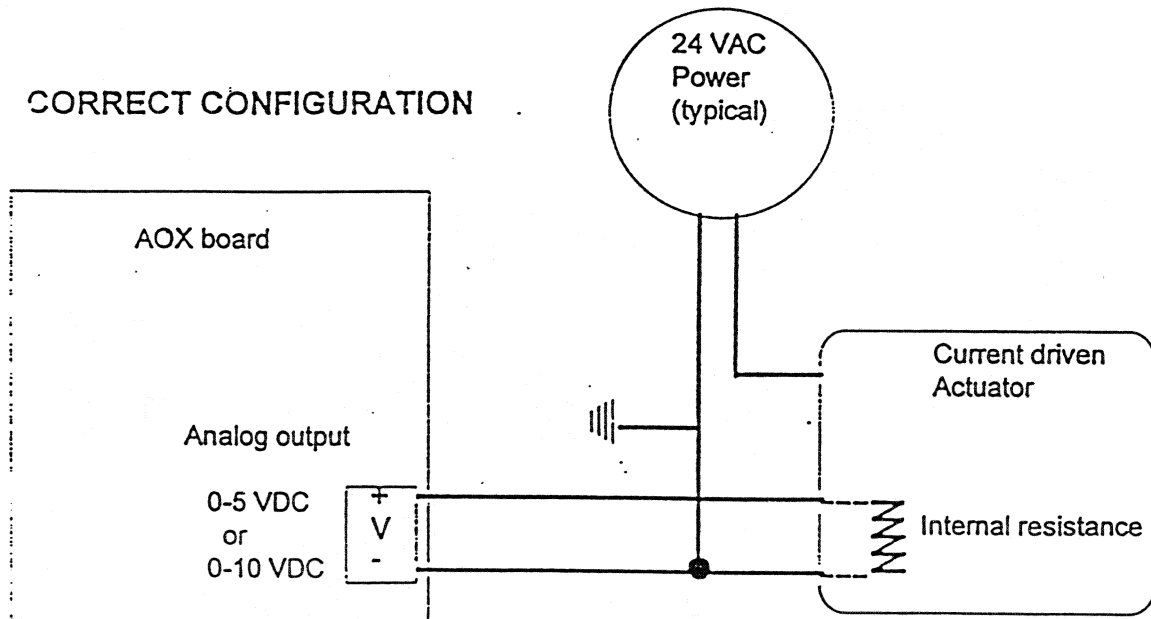

Fig. 1-7 Correct Configuration for Voltage Mode (return line grounded)

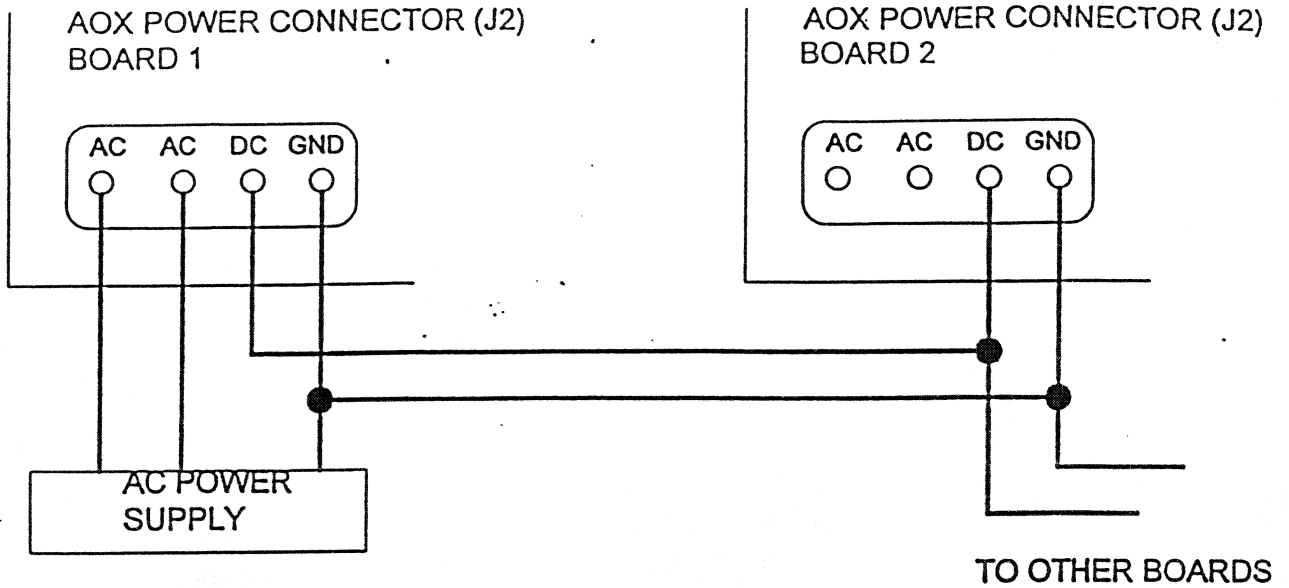

Fig. 2-2 Power Connections with Daisy Chaining

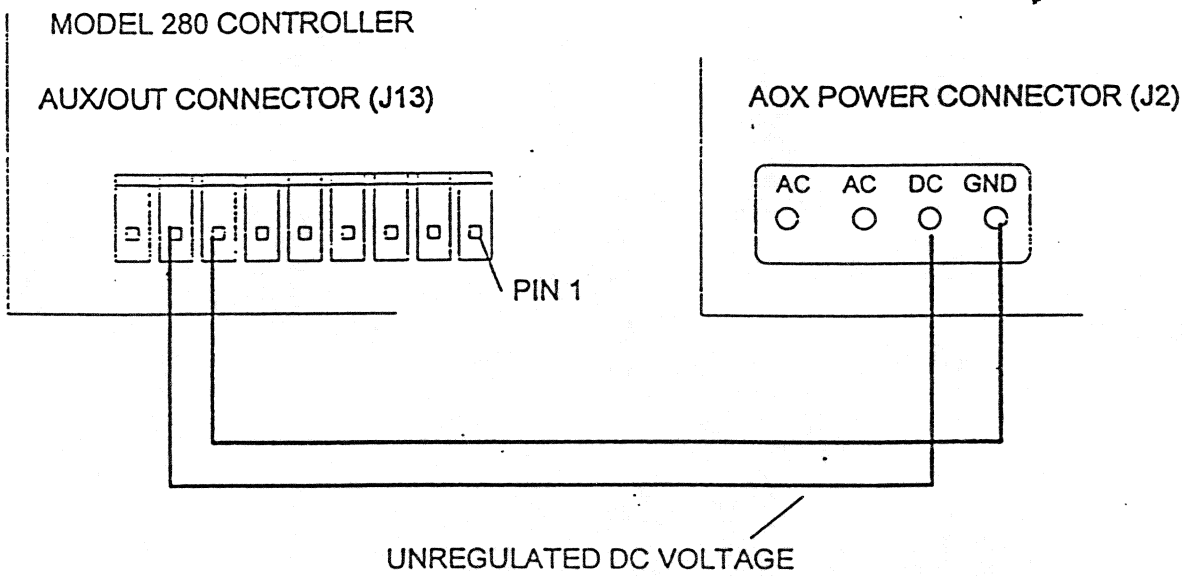

Fig. 2-3 Power Delivery from Model 280 Controller

SECTION 2 - OPERATION

2.1 POWER REQUIREMENTS

The AOX board may be powered by either unregulated 10-20 VDC or 16-24 VAC. If any of the analog outputs are set to 0-10 V, the power input to the AOX board should be at least 10.5 V. The required connections for a board powered by an AC or DC power supply unit are shown in Figure 2-1 below. For daisy chaining, the ground and DC pins of all the power connectors can be tied together as shown in Figure 2-2 or each board may be powered separately by either AC power or DC power as shown in Figure 2-1. Power to the board can also be brought from the Model 280 EnGinn controller as shown in Figure 2-3. Note: the boards may share a DC power supply but not an A.C. supply.

Power to the AOX board should be cut when changing signal settings (with the jumpers) or plugging and unplugging cables. Also, power should be applied and removed at the same time it is being applied or removed to the Model 280 EnGinn controller. One green and one red diagnostic LED are present on each board to indicate the state of power on the board. The green LED is lit when power delivery to the board is normal. The red LED is lit when power delivery is normal but a current overload is present somewhere on the board.

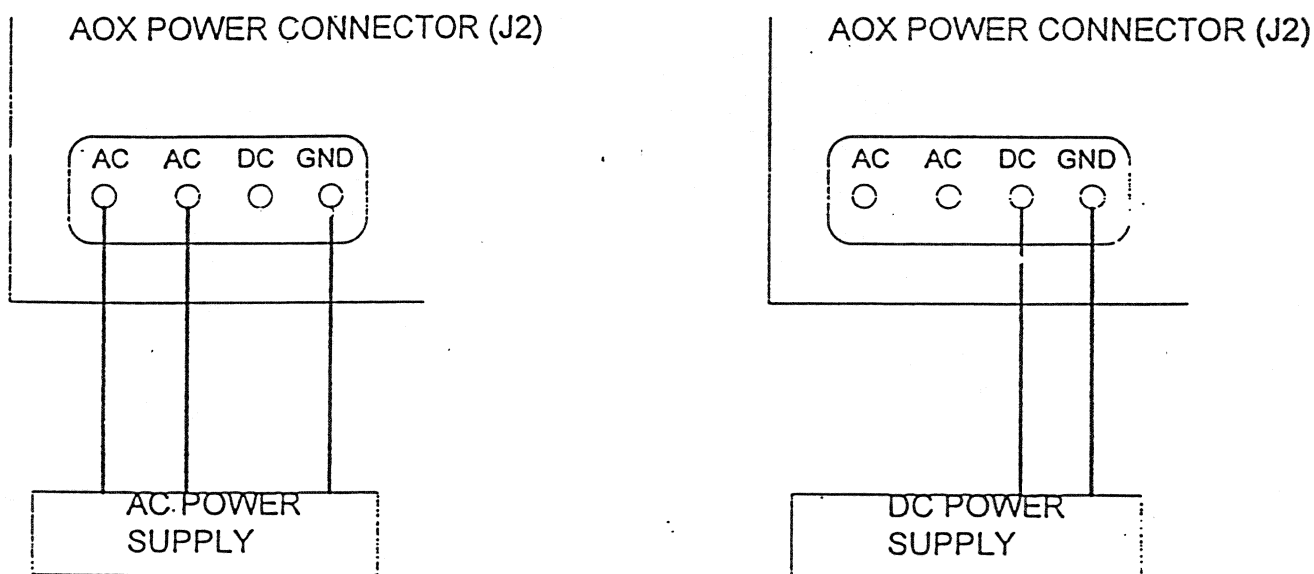
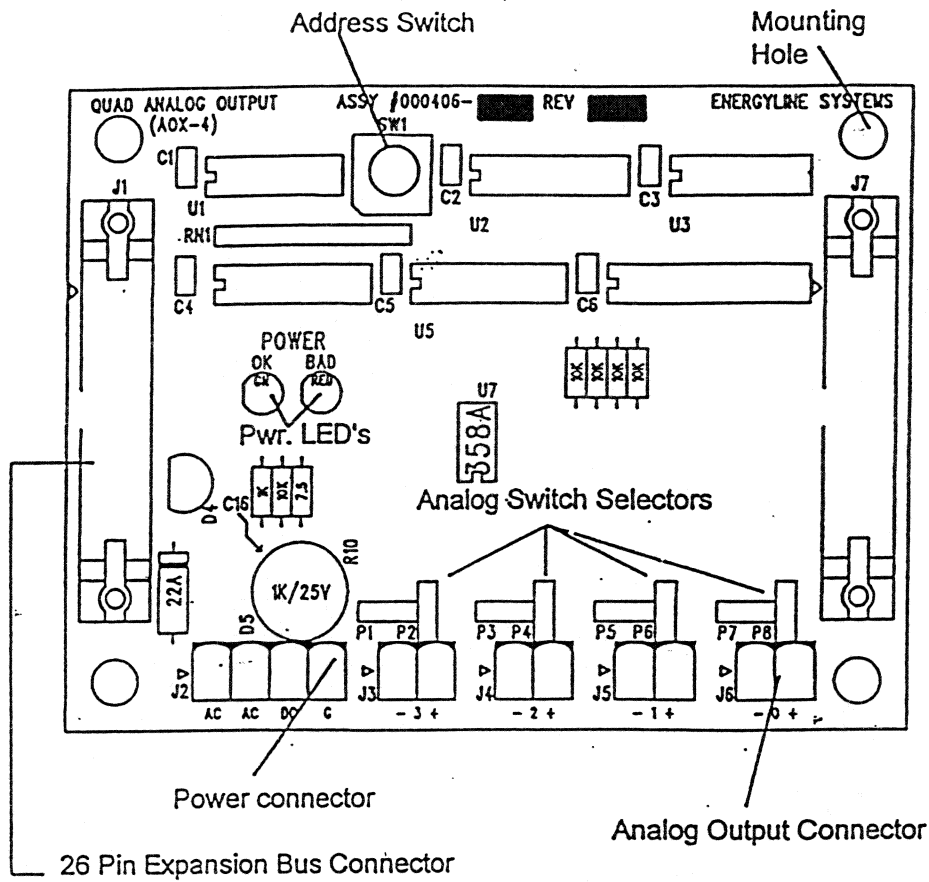

Fig. 2-1 Power Connections with No Daisy Chaining



AOX-4 BOARD

Output 0 - Cooling Tower By Pass valve

- 1 - motor Amps
0-5 VDC
- 0-10 VDC
- 4-20 ma DC

Simulate output from AOX-4 board.

Set correct checksum (0A01) to a value different from (0A02) and reset controller by cycling power.

Check HEX switch on AOX-4 board. This setting should be ZERO (0). If you change the HEX switch, you must cycle power to the controller.

Write to memory location (0B00) a value between 0 - 255. The output will be proportional. ZERO (0) will equal ZERO (0) if the valve type was selected as NC in menu 20. 255 will equal full output depending on the type of output selected by the AOX-4 board analog switch selectors.

If the AOX-4 board performs properly, check the selections in menu 19 and 20. I have attached a sample of each menu with the settings that should get you operating. You will have to make some changes to match your systems requirements.

Reset the correct check sum to (0A01) and recycle the power to the controller.

Service Bulletin

SB Number: 20-9626-B
Originator: DH
Supersedes:

Date: October 3, 1996
Code: 20

Page 1 of 2

APROTEK (brand name) Modem

This is the modem that is currently being provided as an option on all units with MicroTech controls. The complete assembly consists of the following:

1. Modem part # 0594769-01
2. Modem Interface part #0733727-02
3. Modem Connector part # 0594767-01
4. Mounting Brackets part # 0730147-01 and 0730435-05

Items 1-3 are required for a complete operating modem, mounting brackets are optional.

Connection Table

Unit Type	Terminal No.	Description
ALS	57	12 - 18 vdc unregulated power supply
ALR	146	12 - 18 vdc unregulated power supply
WHR	146	12 - 18 vdc unregulated power supply
PFS-A	57	12 - 18 vdc unregulated power supply
PFS-B	91	12 - 18 vdc unregulated power supply
200 CENT	98	12 - 18 vdc unregulated power supply
100 CENT	67	12 - 18 vdc unregulated power supply

The red wire is connected to the terminal indicated above. The white wire is NOT ground. Ground is provided through the number 5 terminal on the amp adapter that plugs into port A of the stand alone unit or port A of the Slave unit. Cut off or wire tie the white wire.

SB #20-9626-B
October 3, 1996
Page 2

The code string is down loaded at the factory. If this string becomes corrupted, it can be reloaded with any standard communications package. Microsoft Windows has a terminal package that can be used. The control string is as follows:

AT&F0S0=1B0E0Q1&D0&K0&W0

The following table describes the AT commands used in the initialization string.
0=ZERO

&F0	Restore factory settings
S0=1	Enables Auto Answer
B0	CCITT Standard
E0	Disable Char Echo
Q1	No Results Codes
&D0	Ignore DTR
&K0	Disable Flow Control
&W0	WriteCurrent Settings to NVRAM Template 0

Service Bulletin

SB Number: 20-9627-B
Originator: DH
Supersedes:

Date: December 6, 1996
Code: 20

Page 1 of 2

Series 200 MicroTech PF Units or Dual PE Units with Lead Lag Configuration

The following procedure provides the necessary information to network two series 200 MicroTech controls in the lead/lag configuration.

1. Select which Microtech will be configured as the master and perform steps 2 through 7.
2. The RS-485 plug must be in port A. This is the plug with wires in plug numbers 5,3,4.
3. Set Hex address hi=0, lo=1.
4. Menu 26 [Unit Setup]
 - a. Screen 1 Line 2 [Config=L2-Master-Slave]
 - b. Screen 2 Line 1 [Master/Slave=Master]
5. Menu 23 [Lead Lag Setup]
 - a. Screen 1 Line 1 [Slave Address=01.01]
 - b. Screen 1 Line 2 [Start Up=Unload] You have to select unload if the network is for a PFH Chiller.
6. Menu 11 [Control Mode]
 - a. Auto:Local
7. Menu 12 [Leaving Evap Setpoints]
 - a. SptSource=Local
8. Go to Slave MicroTech and perform steps 9 through 12.
9. Set Hex address hi=0, lo=1.
10. Menu 26 [Unit Setup]
 - a. Screen 1 Line 2 [Config=L3-TTY-Slave]
 - b. Screen 2 Line 1 [Master/Slave=Slave]
11. Menu 11 [Control Mode]
 - a. Auto:Network

Series 200 MicroTech PF Units or Dual PE Units with Lead Lag Configuration

12. Menu 12 [Leaving Evap Setpoints]
 - a. SptSource=Network
13. Power down both Master and Slave MicroTechs for all settings to be saved. This is only necessary because of the level configuration changes.
14. Go to Menu 9 [Network Status] and check Screen 1 line 3 comm status should be OK.
15. All other settings must be the same on the Master and Slave MicroTechs. If the network communications should fail, each MicroTech panel will default to it's own setpoints.

Service Bulletin

SB Number: 20-9628-B
Originator: DLH
Supersedes:

Date: December 10, 1996
Code: 20

200 Centrifugal Software Version CFGxx03D and later

There were several changes to the referenced software in June of 1996. These changes are present in all software versions since this release. To use the modifications requires writing to specific memory locations. Please check the memory locations for proper default values before writing new values. This will eliminate errors.

1. This version eliminated the clearing of timers from the key pad. To accomplish clearing timers, the service password must be entered.
2. An accessible timer to increase the time the condenser pump can run before flow is confirmed was added. This is the CondMaxWaterPmpStartTime and is memory location 08A0. Default time is 15 seconds. This is an EPL timer and will have a default value of HEX 4F or decimal 79. Consult Service Bulletin on EPL timers in section 20.
3. An accessible timer to increase the time the evaporator pump can run before flow is confirmed was added. This is the EvapMaxWaterPmpStartTime and is memory location 089F. Default time is 15 seconds. This is an EPL timer and will have a default value of HEX 4F or decimal 79. Consult Service Bulletin on EPL timers in section 20.
4. Low discharge superheat alarm on chillers with liquid injection filled the alarm buffers and created nuisance alarms. An alarm point was installed that allows defeating this alarm. The point is DisSpHtAlm and memory location 08A3. The default value is 01 for on. Set to 00 for off.
5. There is an alarm named "EvaporatorFreezeProtect" and it is classified as a problem. If the evaporator temperature goes below the freeze protect setpoint, the evaporator pump is turned on. If the evaporator temperature goes above setpoint plus startup differential, the pump is turned off. This could cause the evaporator pump to operate under specific conditions. Lock out the evaporator pump if performing service.

The above changes will be in all later releases.

Service Bulletin

SB Number: 20-9629-B
Originator: DLH
Supersedes:

Date: December 10, 1996
Code: 20

Page 1 of 2

EPL Timers

EPL Timers are part of the programming language used in all MicroTech programs. All timers are not the EPL type and if in doubt, please call Technical Support to confirm type of timer. The information that will be presented will apply to all MicroTech products.

To convert binary values in 'EPL' Timers to units of time in seconds, minutes or hours. Read the memory location in HEX value and convert to decimal value or read in decimal value and use the following to convert to time.

1. If decimal number is less than 64, multiply it by 0.1 to convert to seconds.
2. If decimal number is greater than 64 but less than 128, subtract 64 and the value will be in seconds.
3. If decimal number is greater than 128 but less than 192, subtract 128 and the value will be in minutes.
4. If the decimal value is greater than 192, subtract 192 and the value will be in hours.

Examples:

Decimal value = 58; $58 \times 0.1 = 5.8$ seconds
Decimal value = 96; $96 - 64 = 32$ seconds
Decimal value = 138; $138 - 128 = 10$ minutes
Decimal value = 244; $244 - 192 = 52$ hours

A simple chart for converting HEX to decimal and decimal to HEX is provided for your convenience.

Converting HEX values to decimal values.

HEX			DECIMAL			HEX		DECIMAL	
VALUE			VALUE			VALUE		VALUE	
00	-	0F	00	-	15	00	00		
10	-	1F	16	-	31	01	01		
20	-	2F	32	-	47	02	02		
30	-	3F	48	-	63	03	03		
40	-	4F	64	-	79	04	04		
50	-	5F	80	-	95	05	05		
60	-	6F	96	-	111	06	06		
70	-	7F	112	-	127	07	07		
80	-	8F	128	-	143	08	08		
90	-	9F	144	-	159	09	09		
A0	-	AF	160	-	175	A	10		
B0	-	BF	176	-	191	B	11		
C0	-	CF	192	-	207	C	12		
D0	-	DF	208	-	223	D	13		
E0	-	EF	224	-	239	E	14		
F0	-	FF	240	-	255	F	15		

Service Bulletin

SB Number: SB 20 9730

Originator: WGF

Supersedes: None

Date: 3.24.1997

Code:

MicroTech Low Motor Current Trips

With the introduction of the 200 Series MicroTech control for Centrifugal Chillers in 1994, a nuisance trip condition surfaced. Following shutdown, the display might read "Low Motor Current".

The statement should be interpreted to mean that the chiller did not shut down on chilled water temperature, a panel switch, or on a manually reset protective control. It did shut down because a contact in the MCR (Motor Control Relay) coil circuit opened.

If the offending contact reclosed, the micro processor would be unable to identify the specific fault. It would simply display "Low Motor Current" as the result of the shutdown, not the cause.

Contacts in the MCR coil circuit include the oil pressure protector, the refrigerant high pressure protector, MCR contacts, a starter auxiliary contact, starter overloads, and miscellaneous other safeties such as under and over voltage protectors and phase failure devices.

In some instances, the culprit has been found to be the High Refrigerant Pressure Protector opening at an abnormally low pressure and resetting after having interrupted the circuit.

Whenever this condition occurs, the technician might be wise to use a "Tattle Tale" type device to pinpoint the source of the fault.

McQuayService™
Air Conditioning

Service Bulletin

SB Number: 20-9731-B
 Originator: PCM
 Supersedes:

Date: 11/3/97
 Code:20

MicroTech Released Software

The following is a list of the latest released software. Please install the latest software when visiting a job site. **DO NOT** make a special trip just to change the software.

Released Software	Text	Refrigerant	Type of Unit
cfg1e04g.cod	English	R-12	Centrifugal (200 Series)
cfg1s04g.cod	Metric	R-12	Centrifugal (200 Series)
cfg3e04g.cod	English	R-134a	Centrifugal (200 Series)
cfg3s04g.cod	Metric	R-134a	Centrifugal (200 Series)
cfg5e04g.cod	English	R-500	Centrifugal (200 Series)
cfg5s04g.cod	Metric	R-500	Centrifugal (200 Series)
pes2e03a.cod	English	R-22	PFS-B Flooded
pes2s03a.cod	Metric	R-22	PFS-B Flooded
pes3e03a.cod	English	R-134a	PFS-B Flooded
pes3s03a.cod	Metric	R-134a	PFS-B Flooded
pes4e03a.cod	English	R-410a	PFS-B Flooded
pes4s03a.cod	Metric	R-410a	PFS-B Flooded
flu2e01c.cod	English	R-22	PFS-C Flooded
flu2s01c.cod	Metric	R-22	PFS-C Flooded
flu3e01c.cod	English	R-134a	PFS-C Flooded
flu3s01c.cod	Metric	R-134a	PFS-C Flooded
flu4e01c.cod	English	R-410a	PFS-C Flooded
flu4s01c.cod	Metric	R-410a	PFS-C Flooded
rcp2e02f.cod	English	R-22	Reciprocating-WHR/ALR
rcp2s02f.cod	Metric	R-22	Reciprocating-WHR/ALR
rcp3e02f.cod	English	R-134a	Reciprocating-WHR/ALR
rcp3s02f.cod	Metric	R-134a	Reciprocating-WHR/ALR
sc12u01b.cod	English/Metric	R-22	ALS 1 Compr
sc13u01b.cod	English/Metric	R-134a	ALS 1 Compr
sc22u20k.cod	English/Metric	R-22	ALS 2 Compr
sc23u20k.cod	English/Metric	R-134a	ALS 2 Compr
sc32u20m.cod	English/Metric	R-22	ALS 3 Compr
sc33u20m.cod	English/Metric	R-134a	ALS 3 Compr
sc42e20m.cod	English	R-22	ALS 4 Compr
sc42s20m.cod	Metric	R-22	ALS 4 Compr
sc43e20m.cod	English	R-134a	ALS 4 Compr
sc43s20m.cod	Metric	R-134a	ALS 4 Compr

McQuayService
 Air Conditioning

Service Bulletin

SB Number: 20-9832-B

Originator: PCL

Supersedes: 20-9731-B

Date: 1/9/98

Code:20

MicroTech Released Software

The following is a list of the latest released software. Please install the latest software when visiting a job site. **DO NOT** make a special trip just to change the software.

Released Software	Text	Refrigerant	Type of Unit
cfg1e04g.cod	English	R-12	Centrifugal (200 Series)
cfg1s04g.cod	Metric	R-12	Centrifugal (200 Series)
cfg3e04g.cod	English	R-134a	Centrifugal (200 Series)
cfg3s04g.cod	Metric	R-134a	Centrifugal (200 Series)
cfg5e04g.cod	English	R-500	Centrifugal (200 Series)
cfg5s04g.cod	Metric	R-500	Centrifugal (200 Series)
pes2e03a.cod	English	R-22	PFS-B Flooded
pes2s03a.cod	Metric	R-22	PFS-B Flooded
pes3e03a.cod	English	R-134a	PFS-B Flooded
pes3s03a.cod	Metric	R-134a	PFS-B Flooded
pes4e03a.cod	English	R-410a	PFS-B Flooded
pes4s03a.cod	Metric	R-410a	PFS-B Flooded
flu2e01b.cod	English	R-22	PFS-C Flooded
flu2s01b.cod	Metric	R-22	PFS-C Flooded
flu3e01b.cod	English	R-134a	PFS-C Flooded
flu3s01b.cod	Metric	R-134a	PFS-C Flooded
flu4e01b.cod	English	R-410a	PFS-C Flooded
flu4s01b.cod	Metric	R-410a	PFS-C Flooded
rcp2e02f.cod	English	R-22	Reciprocating-WHR/ALR
rcp2s02f.cod	Metric	R-22	Reciprocating-WHR/ALR
rcp3e02f.cod	English	R-134a	Reciprocating-WHR/ALR
rcp3s02f.cod	Metric	R-134a	Reciprocating-WHR/ALR
sc12u01b.cod	English/Metric	R-22	ALS 1 Compr
sc13u01b.cod	English/Metric	R-134a	ALS 1 Compr
sc22u20l.cod	English/Metric	R-22	ALS 2 Compr
sc23u20l.cod	English/Metric	R-134a	ALS 2 Compr
sc32u20m.cod	English/Metric	R-22	ALS 3 Compr
sc33u20m.cod	English/Metric	R-134a	ALS 3 Compr
sc42e20m.cod	English	R-22	ALS 4 Compr
sc42s20m.cod	Metric	R-22	ALS 4 Compr
sc43e20m.cod	English	R-134a	ALS 4 Compr
sc43s20m.cod	Metric	R-134a	ALS 4 Compr

McQuayService
Air Conditioning

Service Bulletin

SB Number: 20-9833-B

Originator: MDD

Supersedes:

Date: 4/27/98

Code: 20

SOFTWARE DOWNLOAD PROCEDURE CHANGE

In the past it was common practice to save passwords and port configurations when downloading new software in to a chiller. We have since learned that saving port configurations can corrupt the code under certain circumstances. This shows up when strange or unexplainable things occur in the program.

When doing a download to a MicroTech controller, **DO NOT save port configurations!** Save **only the passwords** and let the new code set the default port configurations.

If it is desired to save the hours and starts, select the specific address block in the download/save/restore window in the save options section and just type in the memory address that you want to save. If multiple addresses need to be saved, just separate them with a comma.

Service Bulletin

SB Number: 20-9834-B
Originator: PCL
Supersedes:

Date: 6/12/01
Code: 20

Updating PFS-C Units' Current Software

A new version of software for PFS -C Vintage chillers is now available. This is software FLU_E02B.cod for English units and FLU_S02B.cod for Metric or SI units. This code has sent to all field offices and must be installed as soon as possible into all existing and new : up units, regardless of the refrigerant.

The following is a list of the new codes:
FLU2E02B.cod – R22, English units
FLU2S02B.cod – R22, Metric/SI units
FLU3E02B.cod – R134a, English units
FLU3S02B.cod – R134a, Metric/SI units
FLU4E02B.cod – R410A, English units
FLU4S02B.cod – R410A, Metric/SI units

The following is an explanation of the code file nomenclature:

FLU – PFS-C **FL**looded **U**nit

2,3,4 – Refrigerant (2 - R22, 3 - R-134a, or 4 - R410A)

E/S – Units (E – English, S – Metric/SI)

02 – Version

B – Revision

.cod – Code File (meaning do not try to open file, it is not a readable file – **FOR
DOWNLOADING ONLY**)

This code addresses the following:

1. Lag compressor flashing off and then back on when both compressors were running and the manual setpoint was set to Manual Off.
2. Addition of Lag Compressor Standby capability to the unit.
3. Put limits in for future use with BACDrop.
4. Deleted invisible character on label 18 in Metric version of software, which was causing display problem.
5. Corrected incorrect letters showing on label 18 of English version of software,
6. Corrected the factor which were used for WaterPresRatio and RefrgPresRatio on Menu Refrig Temps/Press (Metric Units)
7. Deleted unused item Spt Source and Cond WT on Menu 8 – Lvg Evap Spts, these were not used.
8. Corrected softload being activated every time the circuit starts, when it should only be activated when the first circuit starts.

SB-20-9834-B

2 of 2

9. Remote start/stop switch will now shut down the unit when only one compressor is running.
10. OffAmbientLock will not happen in the CoolStaging and ShutPumpdown modes. Changed the OAT sensor conversion to match the AmbLockoutTSpt
11. Corrected the problem of the unit always starting compressor #2 by having the unit always start the compressor with the fewest number of starts and the unit increasing the cooling capacity by running the compressor with the fewest run hours.
12. Enable the unit to shut down when the unit alarms on LoEvapPressSdOn.
13. HiMotorCurrentOn alarm is enabled.
14. Corrected the problem of one compressor is in OffPumpdownSW status and the other compressor is in running mode, and the compressor which is in the OffPumpdownSW status comes out of that status, then the unit will go to stage 8 (both compressors running at full capacity).

Note: The only known uncorrected issue at the time of the release of this version of this software is the condenser pump continuing to run after unit has shutdown.

Service Bulletin

SB Number: 20-9835-B
Originator: PCL
Supersedes: 20-9832-B

Date: 6/8/98
Code: 20

Page 1 of 4

MicroTech Released Software

The following is a list of the latest released software. Please install the latest software when visiting a jobsite. **DO NOT** make a special trip just to change the software, with the exception of the previous service bulletin 20-9834-B.

Software	Text	Refrigerant	Type of Unit	Notes
Centrifugal Units - 100 Series				
<u>Standalone Unit or w/ Open Protocol Only</u>				
pc208g.cod	refer to display cartridge software id	R-12	Centrifugal (100 Series)	Logic Cartridge (slave)
pc408h.cod	refer to display cartridge software id	R-134a	Centrifugal (100 Series)	Logic Cartridge (slave)
pdm08h.cod	Metric	refer to logic cartridge software id	Centrifugal (100 Series)	Display Cartridge
pdr08h.cod	English	refer to logic cartridge software id	Centrifugal (100 Series)	Display Cartridge
dua08e.cod	refer to display cartridge software id	refer to logic cartridge software id	Centrifugal (100 Series)	Lead Lag Load Balance Panel (LLLB)
<u>For Units Used w/ CSC or OPM Panels Only</u>				
pc209b.cod	refer to display cartridge software id	R-12	Centrifugal (100 Series)	Logic Cartridge (slave)
pc409b.cod	refer to display cartridge software id	R-134a	Centrifugal (100 Series)	Logic Cartridge (slave)
pdm09b.cod	Metric	refer to logic cartridge software id	Centrifugal (100 Series)	Display Cartridge
pdr09b.cod	English	refer to logic cartridge software id	Centrifugal (100 Series)	Display Cartridge
dua09b.cod	refer to display cartridge software id	refer to logic cartridge software id	Centrifugal (100 Series)	Lead Lag Load Balance Panel (LLLB)

Centrifugal Units - 200 Series				
cfg1e04h.cod	English	R-12	Centrifugal (200 Series)	
cfg1s04h.cod	Metric	R-12	Centrifugal (200 Series)	
cfg3e04h.cod	English	R-134a	Centrifugal (200 Series)	
cfg3s04h.cod	Metric	R-134a	Centrifugal (200 Series)	
cfg5e04h.cod	English	R-500	Centrifugal (200 Series)	
cfg5s04h.cod	Metric	R-500	Centrifugal (200 Series)	
PFS-B Screw Units				
pes2e03a.cod	English	R-22	PFS-B Flooded	2 control boxes
pes2s03a.cod	Metric	R-22	PFS-B Flooded	2 control boxes
pes3e03a.cod	English	R-134a	PFS-B Flooded	2 control boxes
pes3s03a.cod	Metric	R-134a	PFS-B Flooded	2 control boxes
pes4e03a.cod	English	R-410a	PFS-B Flooded	2 control boxes
pes4s03a.cod	Metric	R-410a	PFS-B Flooded	2 control boxes

PFS-C Screw Units				
flu2e02b.cod	English	R-22	PFS-C Flooded	1 control box
flu2s02b.cod	Metric	R-22	PFS-C Flooded	1 control box
flu3e02b.cod	English	R-134a	PFS-C Flooded	1 control box
flu3s02b.cod	Metric	R-134a	PFS-C Flooded	1 control box
flu4e02b.cod	English	R-410a	PFS-C Flooded	1 control box
flu4s02b.cod	Metric	R-410a	PFS-C Flooded	1 control box

ALR/WHR Reciprocating Units				
rcp2e02g.cod	English	R-22	Reciprocating-WHR/ALR	
rcp2s02g.cod	Metric	R-22	Reciprocating-WHR/ALR	
rcp3e02g.cod	English	R-134a	Reciprocating-WHR/ALR	
rcp3s02g.cod	Metric	R-134a	Reciprocating-WHR/ALR	

ALS Screw Units - 1 Compressor				
sc12u01l.cod	English/Metric	R-22	ALS 1 Compr	
sc13u01l.cod	English/Metric	R-134a	ALS 1 Compr	

ALS/PFS-A Screw Units - 2 Compressor				
sc22u20m.cod	English/Metric	R-22	PFS-A/ALS 2 Compr	
sc23u20m.cod	English/Metric	R-134a	PFS-A/ALS 2 Compr	

ALS Screw Units - 3 Compressor				
sc32u20m.cod	English/Metric	R-22	ALS 3 Compr	
sc33u20m.cod	English/Metric	R-134a	ALS 3 Compr	

ALS Screw Units - 4 Compressor				
sc42e20m.cod	English	R-22	ALS 4 Compr	
sc42s20m.cod	Metric	R-22	ALS 4 Compr	
sc43e20m.cod	English	R-134a	ALS 4 Compr	
sc43s20m.cod	Metric	R-134a	ALS 4 Compr	

Global Scroll Units

gz_2e01a.cod	English	R-22	Global Scroll
gz_2s01a.cod	Metric	R-22	Global Scroll

Global Reciprocating Units

rcp2e02g.cod	English	R-22	Global Recip
rcp2s02g.cod	Metric	R-22	Global Recip
rcp3e02g.cod	English	R-134a	Global Recip
rcp3e02g.cod	Metric	R-134a	Global Recip

Service Bulletin

SB Number: 20-9836-B

Originator: JND

Supersedes:

Date: 6/15/98

Code: 20

PFS-C StartUp Procedure

In addition to the normal startup procedure, which can be found on McQuay Online, the following is required:

1. Install the latest software. Contact Paula Lee of John Drumheller in Technical Support to obtain the latest software. (02) Refer SB-20-9834—B for details on the software.
2. If an Energy Management System (EMS) is installed – After the unit settles out make sure the minimum temperature difference between the leaving evaporator water temperature and the entering condenser water is 23°F. The intent of this is to avoid operating the unit with high evaporator water and low condenser water for extended periods of time.
3. The condenser pump should be cycled off when both compressors are off.
4. Set the timer for the starter contactors to the minimum value. This timer determines the time delay between the first contactor and the second contactor.

Note: If any other problems are found at startup, please contact John Drumheller or Tom Watson immediately.

Service Bulletin

SB Number: 20-9837-B
Originator: MDD
Supersedes:

Date: 6/22/ 98
Code: 20

PFSC FLU__O2B.COD

The latest PFSC code, FLUxx02B has a minor intermittent "glitch" in it. When the lag compressor turns off by the remote signal or is shut down using the manual pumpdown mode from the MicroTech key pad and in one instance it was discovered when the chilled water setpoint was turned up from 45 to 55 degrees. The compressor will stop, stay off for approximately 1 second, start up again for approximately 1 second then shut off and stay off. This is not detrimental to the unit as the compressor makes a full start as opposed to a "chatter" but we are trying to identify the source of the problem as it does not happen on all units all of the time.

If anyone experiences this phenomenon, Please contact the technical support people in Staunton so we can document the job and inquire in to the application.

John Drumheller	540-248-9575	e-mail	john.drumheller@mcquay.com
Paula Lee	540-248-9576	e-mail	paul.lee@mcquay.com
Don Derfler	540-248-9496	e-mail	don.derfler@mcquay.com

Service Bulletin

SB Number: 20-9838-B

Originator: PCL

Supersedes: 20-9835-B

Date: 7/2/98

Code: 20

Page 1 of 4

MicroTech Released Software

The following is a list of the latest released software. Please install the latest software when visiting a jobsite. **DO NOT** make a special trip just to change the software, with the exception of the previous service bulletin 20-9834-B.

Software	Text	Refrigerant	Type of Unit	Notes
Centrifugal Units - 100 Series				
<u>Standalone Unit or w/ Open Protocol Only</u>				
pc208g.cod	refer to display cartridge software id	R-12	Centrifugal (100 Series)	Logic Cartridge (slave)
pc408h.cod	refer to display cartridge software id	R-134a	Centrifugal (100 Series)	Logic Cartridge (slave)
pdm08h.cod	Metric	refer to logic cartridge software id	Centrifugal (100 Series)	Display Cartridge
pdr08h.cod	English	refer to logic cartridge software id	Centrifugal (100 Series)	Display Cartridge
dua08e.cod	refer to display cartridge software id	refer to logic cartridge software id	Centrifugal (100 Series)	Lead Lag Load Balance Panel (LLLB)
<u>For Units Used w/ CSC or OPM Panels Only</u>				
pc209b.cod	refer to display cartridge software id	R-12	Centrifugal (100 Series)	Logic Cartridge (slave)
pc409b.cod	refer to display cartridge software id	R-134a	Centrifugal (100 Series)	Logic Cartridge (slave)
pdm09b.cod	Metric	refer to logic cartridge software id	Centrifugal (100 Series)	Display Cartridge
pdr09b.cod	English	refer to logic cartridge software id	Centrifugal (100 Series)	Display Cartridge
dua09b.cod	refer to display cartridge software id	refer to logic cartridge software id	Centrifugal (100 Series)	Lead Lag Load Balance Panel (LLLB)

Centrifugal Units - 200 Series			
cfg1e04h.cod	English	R-12	Centrifugal (200 Series)
cfg1s04h.cod	Metric	R-12	Centrifugal (200 Series)
cfg3e04h.cod	English	R-134a	Centrifugal (200 Series)
cfg3s04h.cod	Metric	R-134a	Centrifugal (200 Series)
cfg5e04h.cod	English	R-500	Centrifugal (200 Series)
cfg5s04h.cod	Metric	R-500	Centrifugal (200 Series)

PFS-B Screw Units				
pes2e03a.cod	English	R-22	PFS-B Flooded	2 control boxes
pes2s03a.cod	Metric	R-22	PFS-B Flooded	2 control boxes
pes3e03a.cod	English	R-134a	PFS-B Flooded	2 control boxes
pes3s03a.cod	Metric	R-134a	PFS-B Flooded	2 control boxes
pes4e03a.cod	English	R-410a	PFS-B Flooded	2 control boxes
pes4s03a.cod	Metric	R-410a	PFS-B Flooded	2 control boxes

PFS-C Screw Units				
flu2e02b.cod	English	R-22	PFS-C Flooded	1 control box
flu2s02b.cod	Metric	R-22	PFS-C Flooded	1 control box
flu3e02b.cod	English	R-134a	PFS-C Flooded	1 control box
flu3s02b.cod	Metric	R-134a	PFS-C Flooded	1 control box
flu4e02b.cod	English	R-410a	PFS-C Flooded	1 control box
flu4s02b.cod	Metric	R-410a	PFS-C Flooded	1 control box

ALR/WHR Reciprocating Units			
rcp2e02g.cod	English	R-22	Reciprocating-WHR/ALR
rcp2s02g.cod	Metric	R-22	Reciprocating-WHR/ALR
rcp3e02g.cod	English	R-134a	Reciprocating-WHR/ALR
rcp3s02g.cod	Metric	R-134a	Reciprocating-WHR/ALR

ALS Screw Units - 1 Compressor			
sc12u01b.cod	English/Metric	R-22	ALS 1 Compr
sc13u01b.cod	English/Metric	R-134a	ALS 1 Compr

ALS/PFS-A Screw Units - 2 Compressor			
sc22u20m.cod	English/Metric	R-22	PFS-A/ALS 2 Compr
sc23u20m.cod	English/Metric	R-134a	PFS-A/ALS 2 Compr

ALS Screw Units - 3 Compressor			
sc32u20m.cod	English/Metric	R-22	ALS 3 Compr
sc33u20m.cod	English/Metric	R-134a	ALS 3 Compr

ALS Screw Units - 4 Compressor			
sc42e20m.cod	English	R-22	ALS 4 Compr
sc42s20m.cod	Metric	R-22	ALS 4 Compr
sc43e20m.cod	English	R-134a	ALS 4 Compr
sc43s20m.cod	Metric	R-134a	ALS 4 Compr

Global Scroll Units			
gz_2e01a.cod	English	R-22	Global Scroll
gz_2s01a.cod	Metric	R-22	Global Scroll

Global Reciprocating Units			
rcp2e02g.cod	English	R-22	Global Recip
rcp2s02g.cod	Metric	R-22	Global Recip
rcp3e02g.cod	English	R-134a	Global Recip
rcp3e02g.cod	Metric	R-134a	Global Recip

Service Bulletin

*SBN*Number: 18-9955B/20-9939-B/37-9940B/44-9919B

Date: 01/12/99

Originator: JLR

Supersedes:

Code: 18/20 /37/44

TEXAS INSTRUMENT LOW PRESSURE TRANSDUCERS

Due to upgrades in component reliability please verify that current production components are incorporated when inspecting and servicing systems using these parts:

	Old Transducers	New Transducers
Low Pressure (Blue dot)	065816801	350105301
High Pressure (Red Dot)	065816802	350105401

Replace **all** low pressure transducers with the new part number. Replace **any failed** high transducers with the new part number. **DO NOT continue to use the old part numbers as replacements.**

Transducer body is now **brass** and ph balanced sealant is used. This TI transducer is used in all ALS/PFS units with MicroTech controllers, Global units with UNT Metasys controllers, and Centrifugal units with MicroTech 200-series controllers.

The boot should be trimmed back to expose the brass body and a wire tie used to hold the boot on the transducer.

All removed parts should be returned for vendor credit.

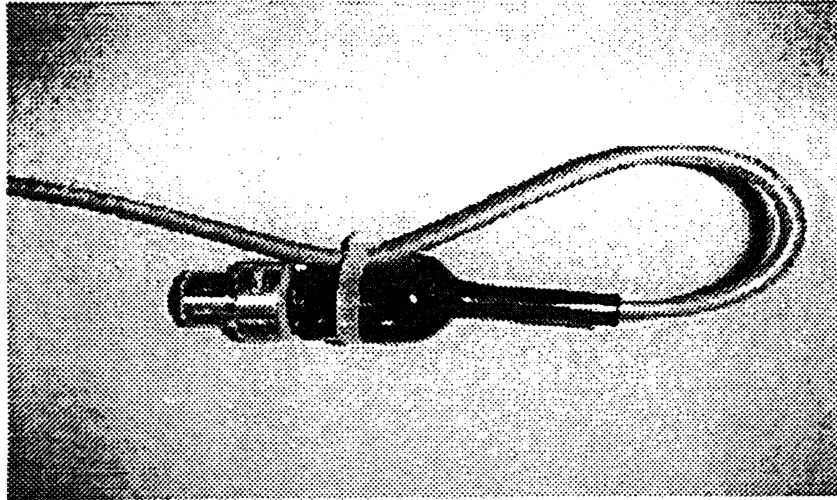

Service Bulletin

SB Number:49-9905-B/20-9940-B

Originator: PDH

Supersedes:

Code:49/20

Date:02/20/99

Chiller System Controller Issues

The current versions of CSC code (CSC1E01F and CSC1S01F) do not work properly with the PFS-C or WHS chillers. Do not attempt to start a CSC network containing these screw chillers using this version of CSC code.

If you have already tried to start this type of system, you have noticed that the staging is very erratic and several chiller values are improperly reported to the CSC.

The new version of the CSC code eliminates the chiller type "Screw" and adds the chiller types "ALS" and "WHS". **Note:** This version has also been tested and shown to be **Y2k compliant**.

The new versions of the code, CSC1E01G and CSC1S01G, are now available. The software code can be found on Microsoft Exchange under Public Folders – McQuayService – Codes/Monitors. All service managers and supervisors should have access to this folder.

Service Bulletin

SB Number:20-9941-B

Originator: PDH

Supersedes:

Date:02/22/99

Code:20

Series 100 MicroTech Hours and Starts

The operating hours and starts for the series 100 chillers are as follows:

Description	Ram	EEPROM
Operating Hours (High Byte)	0430	083D
Operating Hours (Low Byte)	0431	083E
Starts (High Byte)	0432	083F
Starts (Low Byte)	0433	0840

If you have just downloaded code and are trying to restore the hours and starts, follow this procedure:

1. Write the proper values to the EEPROM locations listed above.
2. Reset power to the controller.
3. Read both the RAM and EEPROM locations and make sure that they are both read properly.

This process is necessary because the application code writes the values from the EEPROM locations into the RAM locations once on power up and from the RAM locations into the EEPROM locations once every 24 hours.

Service Bulletin

SB Number: 20-9942-B

Originator: PCL

Supersedes: 20-9838-B

Date: 3/5/99

Code: 20

Page 1 of 4

MicroTech Released Software

The following is a list of the latest released software. Please install the latest software when visiting a jobsite. **DO NOT** make a special trip just to change the software, with the exception of the previous service bulletin 20-9835-B. **ALL OF THE SOFTWARE LISTED BELOW IS Y2K COMPLIANT!**

Software	Text	Refrigerant	Type of Unit	Notes
Centrifugal Units - 100 Series				
<u>Standalone Unit or w/ Open Protocol Only</u>				
pc208g.cod	refer to display cartridge software id	R-12	Centrifugal (100 Series)	Logic Cartridge (slave)
pc408h.cod	refer to display cartridge software id	R-134a	Centrifugal (100 Series)	Logic Cartridge (slave)
pdm08h.cod	Metric	refer to logic cartridge software id	Centrifugal (100 Series)	Display Cartridge
pdr08h.cod	English	refer to logic cartridge software id	Centrifugal (100 Series)	Display Cartridge
dua08e.cod	refer to display cartridge software id	refer to logic cartridge software id	Centrifugal (100 Series)	Lead Lag Load Balance Panel (LLL B)
<u>For Units Used w/ CSC or OPM Panels Only</u>				
pc209b.cod	refer to display cartridge software id	R-12	Centrifugal (100 Series)	Logic Cartridge (slave)
pc409b.cod	refer to display cartridge software id	R-134a	Centrifugal (100 Series)	Logic Cartridge (slave)
pdm09b.cod	Metric	refer to logic cartridge software id	Centrifugal (100 Series)	Display Cartridge
pdr09b.cod	English	refer to logic cartridge software id	Centrifugal (100 Series)	Display Cartridge
dua09b.cod	refer to display cartridge software id	refer to logic cartridge software id	Centrifugal (100 Series)	Lead Lag Load Balance Panel (LLL B)
Centrifugal Units - 200 Series				
cfg1e04i.cod	English	R-12	Centrifugal (200 Series)	
cfg1s04i.cod	Metric	R-12	Centrifugal (200 Series)	
cfg3e04i.cod	English	R-134a	Centrifugal (200 Series)	
cfg3s04i.cod	Metric	R-134a	Centrifugal (200 Series)	
cfg5e04i.cod	English	R-500	Centrifugal (200 Series)	
cfg5s04i.cod	Metric	R-500	Centrifugal (200 Series)	

PFS-B Screw Units				
pes2e03h.cod	English	R-22	PFS-B Flooded	2 control boxes
pes2s03h.cod	Metric	R-22	PFS-B Flooded	2 control boxes
pes3e03h.cod	English	R-134a	PFS-B Flooded	2 control boxes
pes3s03h.cod	Metric	R-134a	PFS-B Flooded	2 control boxes
pes4e03h.cod	English	R-410a	PFS-B Flooded	2 control boxes
pes4s03h.cod	Metric	R-410a	PFS-B Flooded	2 control boxes

PFS-C Screw Units				
flu2e02c.cod	English	R-22	PFS-C Flooded	1 control box
flu2s02c.cod	Metric	R-22	PFS-C Flooded	1 control box
flu3e02c.cod	English	R-134a	PFS-C Flooded	1 control box
flu3s02c.cod	Metric	R-134a	PFS-C Flooded	1 control box
flu4e02c.cod	English	R-410a	PFS-C Flooded	1 control box
flu4s02c.cod	Metric	R-410a	PFS-C Flooded	1 control box

ALR/WHR Reciprocating Units				
rcp2e02g.cod	English	R-22	Reciprocating-WHR/ALR	
rcp2s02g.cod	Metric	R-22	Reciprocating-WHR/ALR	
rcp3e02g.cod	English	R-134a	Reciprocating-WHR/ALR	
rcp3s02g.cod	Metric	R-134a	Reciprocating-WHR/ALR	

ALS Screw Units - 1 Compressor				
sc12u01b.cod	English/Metric	R-22	ALS 1 Compr	
sc13u01b.cod	English/Metric	R-134a	ALS 1 Compr	

ALS/PFS-A Screw Units - 2 Compressor				
sc22u20n.cod	English/Metric	R-22	PFS-A/ALS 2 Compr	
sc23u20n.cod	English/Metric	R-134a	PFS-A/ALS 2 Compr	

ALS Screw Units - 3 Compressor				
sc32u20m.cod	English/Metric	R-22	ALS 3 Compr	
sc33u20m.cod	English/Metric	R-134a	ALS 3 Compr	

ALS Screw Units - 4 Compressor				
sc42e20m.cod	English	R-22	ALS 4 Compr	
sc42s20m.cod	Metric	R-22	ALS 4 Compr	
sc43e20m.cod	English	R-134a	ALS 4 Compr	
sc43s20m.cod	Metric	R-134a	ALS 4 Compr	

Global Scroll Units			
gz_2e01a.cod	English	R-22	Global Scroll
gz_2s01a.cod	Metric	R-22	Global Scroll

Global Reciprocating Units			
rcp2e02g.cod	English	R-22	Global Recip
rcp2s02g.cod	Metric	R-22	Global Recip
rcp3e02g.cod	English	R-134a	Global Recip
rcp3e02g.cod	Metric	R-134a	Global Recip

Service Bulletin

SB Number:20-9943B
Originator: JCK/PCL
Supersedes:

Date:03/15/99
Code:20

Special Release of PFSC Software

Listed below are enhancements made to the 02-version of software. The items listed below apply to the following version of software:

FLU2E02C.cod – R22/English units
FLU3E02C.cod – R134a/English units
FLU4E02C.cod – R410a/English units

Note: Metric units are not available on this special release.

- The condenser pump will now shut down when the compressors shut down.
- Lead compressor pump down switch problem fixed. Previously would shut down both compressors.
- Enabled EXV control to continue to stroke the valve even if it is against the maximum or minimum limit.
- Enhanced the condenser pump control while in freeze mode.
- Corrected a problem with low load condition shutting the EXV causing an alarm on low evaporator pressure.
- Addition of stop-start timer when powering up unit.
- EXV will no longer open when unit is in High Condenser Pressure Unload.
- Enhancement of current alarm transferring data to the alarm buffer after current alarm has been cleared.
- The unit no longer unloads to 25/25.
- Enhanced operation of EXV operation during Low Evaporator Pressure Unload.
- Start to start timer activated when compressor starts.
- Delayed the low evaporator freeze protect the same as in pressure control mode.

This software is available to you through your Regional Project Managers, as well as, MicroSoft Exchange.

Service Bulletin

SB Number: 20-9945-B

Originator: PCL

Supersedes: 20-9942-B

Date: 7/1/99

Code: 20

Page 1 of 4

MicroTech Released Software

The following is a list of the latest released software. Please install the latest software when visiting a job site. **DO NOT** make a special trip just to change the software, with the exception of the previous service bulletin 20-9942-B. **ALL OF THE SOFTWARE LISTED BELOW IS Y2K COMPLIANT!**

Software	Text	Refrigerant	Type of Unit	Notes
Centrifugal Units - 100 Series				
<u>Standalone Unit or w/ Open Protocol Only</u>				
pc208g.cod	refer to display cartridge software id	R-12	Centrifugal (100 Series)	Logic Cartridge (slave)
pc408h.cod	refer to display cartridge software id	R-134a	Centrifugal (100 Series)	Logic Cartridge (slave)
pdm08h.cod	Metric	refer to logic cartridge software id	Centrifugal (100 Series)	Display Cartridge
pdr08h.cod	English	refer to logic cartridge software id	Centrifugal (100 Series)	Display Cartridge
dua08e.cod	refer to display cartridge software id	refer to logic cartridge software id	Centrifugal (100 Series)	Lead Lag Load Balance Panel (LLLB)
<u>For Units Used w/ CSC or OPM Panels Only</u>				
pc209b.cod	refer to display cartridge software id	R-12	Centrifugal (100 Series)	Logic Cartridge (slave)
pc409b.cod	refer to display cartridge software id	R-134a	Centrifugal (100 Series)	Logic Cartridge (slave)
pdm09b.cod	Metric	refer to logic cartridge software id	Centrifugal (100 Series)	Display Cartridge
pdr09b.cod	English	refer to logic cartridge software id	Centrifugal (100 Series)	Display Cartridge
dua09b.cod	refer to display cartridge software id	refer to logic cartridge software id	Centrifugal (100 Series)	Lead Lag Load Balance Panel (LLLB)
CSC PANEL CAN NOT BE USED WITH A LLLB PANEL!!				

Centrifugal Units - 200 Series				
cfg1e04i.cod	English	R-12	Centrifugal (200 Series)	
cfg1s04i.cod	Metric	R-12	Centrifugal (200 Series)	
cfg3e04i.cod	English	R-134a	Centrifugal (200 Series)	
cfg3s04i.cod	Metric	R-134a	Centrifugal (200 Series)	
cfg5e04i.cod	English	R-500	Centrifugal (200 Series)	
cfg5s04i.cod	Metric	R-500	Centrifugal (200 Series)	

PFS-B Screw Units				
pes2e03h.cod	English	R-22	PFS-B Flooded	2 control boxes
pes2s03h.cod	Metric	R-22	PFS-B Flooded	2 control boxes
pes3e03h.cod	English	R-134a	PFS-B Flooded	2 control boxes
pes3s03h.cod	Metric	R-134a	PFS-B Flooded	2 control boxes
pes4e03h.cod	English	R-410a	PFS-B Flooded	2 control boxes
pes4s03h.cod	Metric	R-410a	PFS-B Flooded	2 control boxes

PFS-C Screw Units				
flu2e02d.cod	English	R-22	PFS-C Flooded	1 control box
flu2s02d.cod	Metric	R-22	PFS-C Flooded	1 control box
flu3e02d.cod	English	R-134a	PFS-C Flooded	1 control box
flu3s02d.cod	Metric	R-134a	PFS-C Flooded	1 control box
flu4e02d.cod	English	R-410a	PFS-C Flooded	1 control box
flu4s02d.cod	Metric	R-410a	PFS-C Flooded	1 control box

ALR/WHR Reciprocating Units				
rcp2e02g.cod	English	R-22	Reciprocating-WHR/ALR	
rcp2s02g.cod	Metric	R-22	Reciprocating-WHR/ALR	
rcp3e02g.cod	English	R-134a	Reciprocating-WHR/ALR	
rcp3s02g.cod	Metric	R-134a	Reciprocating-WHR/ALR	

ALS Screw Units - 1 Compressor				
sc12u01n.cod	English/Metric	R-22	ALS 1 Compr	
sc13u01n.cod	English/Metric	R-134a	ALS 1 Compr	

ALS/PFS-A Screw Units - 2 Compressor				
sc22u20n.cod	English/Metric	R-22	PFS-A/ALS 2 Compr	
sc23u20n.cod	English/Metric	R-134a	PFS-A/ALS 2 Compr	

ALS Screw Units - 3 Compressor				
sc32u20n.cod	English/Metric	R-22	ALS 3 Compr	
sc33u20n.cod	English/Metric	R-134a	ALS 3 Compr	

ALS Screw Units - 4 Compressor				
sc42e20p.cod	English	R-22	ALS 4 Compr	Rel. 06/30/99
sc42s20p.cod	Metric	R-22	ALS 4 Compr	Rel. 06/30/99
sc43e20p.cod	English	R-134a	ALS 4 Compr	Rel. 06/30/99
sc43s20p.cod	Metric	R-134a	ALS 4 Compr	Rel. 06/30/99

Global Scroll Units				
gz_2e01a.cod	English	R-22	Global Scroll	
gz_2s01a.cod	Metric	R-22	Global Scroll	

Global Reciprocating Units				
rcp2e02g.cod	English	R-22	Global Recip	
rcp2s02g.cod	Metric	R-22	Global Recip	
rcp3e02g.cod	English	R-134a	Global Recip	
rcp3s02g.cod	Metric	R-134a	Global Recip	

Service Bulletin

SB Number: 20-0047-B
Originator: BDW
Supersedes: 20-9946-B

Date: 03/27/00
Code: 20

Microtech Released Software

The following list contains the current chiller software codes. When visiting a job site, please ensure the latest software code is installed. Do not make a special trip to install the software unless authorized by the Technical Response Center.

Centrifugal 100 Series Stand-Alone or Open Protocol

Code File	Version	Refrigerant	Description
PC208G.cod	N / A	R-12	Logic Cartridge (Slave)
PC408H.cod	N / A	R-134a	Logic Cartridge (Slave)
PDM08H.cod	Metric	N / A	Display Cartridge
PDR08H.cod	English	N / A	Display Cartridge
DUA08E.cod	N / A	N / A	Lead Lag Load Balance Panel (LLLB)

CSC or OPM Panels

PC209B.cod	N / A	R-12	Logic Cartridge (Slave)
PC409B.cod	N / A	R-134a	Logic Cartridge (Slave)
PDM09B.cod	Metric	N / A	Display Cartridge
PDR09B.cod	English	N / A	Display Cartridge
DUA09B.cod	N / A	N / A	Lead Lag Load Balance Panel (LLLB)

Centrifugal 200 Series

Code File	Version	Refrigerant
CFG1E04I.cod	English	R-12
CFG1S04I.cod	Metric	R-12
CFG1C04I.cod	Chinese	R-12
CFG1D04I.cod	Japanese	R-12
CFG3E04I.cod	English	R-134a
CFG3S04I.cod	Metric	R-134a
CFG3C04I.cod	Chinese	R-134a
CFG3D04I.cod	Japanese	R-134a
CFG5E04I.cod	English	R-500
CFG5S04I.cod	Metric	R-500
CFG5C04I.cod	Chinese	R-500
CFG5D04I.cod	Japanese	R-500

PFS-B Screw

Code File	Version	Refrigerant	Description
PES2E03H.cod	English	R-22	2 control boxes / Flooded Evaporator
PES2S03H.cod	Metric	R-22	2 control boxes / Flooded Evaporator
PES3E03H.cod	English	R-134a	2 control boxes / Flooded Evaporator
PES3S03H.cod	Metric	R-134a	2 control boxes / Flooded Evaporator
PES4E03H.cod	English	R-410a	2 control boxes / Flooded Evaporator
PES4S03H.cod	Metric	R-410a	2 control boxes / Flooded Evaporator

PFS-C / WHS Screw

Code File	Version	Refrigerant	Description
FLU2E02D.cod	English	R-22	1 control box / Flooded Evaporator
FLU2S02D.cod	Metric	R-22	1 control box / Flooded Evaporator
FLU3E02D.cod	English	R-134a	1 control box / Flooded Evaporator
FLU3S02D.cod	Metric	R-134a	1 control box / Flooded Evaporator
FLU4E02D.cod	English	R-410a	1 control box / Flooded Evaporator
FLU4S02D.cod	Metric	R-410a	1 control box / Flooded Evaporator

ALS 1 Compressor Screw

Code File	Version	Refrigerant
SC12U20N.cod	E & M	R-22
SC13U20N.cod	E & M	R-134a
SC16U20N.cod	E & M	R-407c

ALS 2 Compressor & PFS-A Screw

Code File	Version	Refrigerant
SC22U20N.cod	E & M	R-22
SC23U20N.cod	E & M	R-134a
SC26U20N.cod	E & M	R-407c

ALS 3 Compressor Screw

Code File	Version	Refrigerant
SC32U20Q.cod	E & M	R-22
SC33U20Q.cod	E & M	R-134a
SC36U20Q.cod	E & M	R-407c

ALS 4 Compressor Screw

Code File	Version	Refrigerant
SC42E20Q.cod	English	R-22
SC42S20Q.cod	Metric	R-22
SC43E20Q.cod	English	R-134a
SC43S20Q.cod	Metric	R-134a
SC46E20Q.cod	English	R-407c
SC46S20Q.cod	Metric	R-407c

AGZ Scroll

Code File	Version	Refrigerant
GZ 2E01A.cod	English	R-22
GZ 2S01A.cod	Metric	R-22

AGR Reciprocating

Code File	Version	Refrigerant
RCP2E02G.cod	English	R-22
RCP2S02G.cod	Metric	R-22
RCP3E02G.cod	English	R-134a
RCP3S02G.cod	Metric	R-134a

ALR&WHR Reciprocating

Code File	Version	Refrigerant
RCP2E02G.cod	English	R-22
RCP2S02G.cod	Metric	R-22
RCP3E02G.cod	English	R-134a
RCP3S02G.cod	Metric	R-134a

Service Bulletin

SB Number: 20-0048-B
Originator: BDW
Supersedes: None

Date: 12/06/00
Code: 20

Ribbon Cable Protection

When changing a control board or ribbon cable, it is recommended to place a strip of self adhesive insulating tape between the ribbon cable and the back side of the control board. Place the self adhesive tape on any ribbon cable that could come into contact with the board's sharp pins. This protective tape will ensure that the pins on the control board do not damage the ribbon cable.

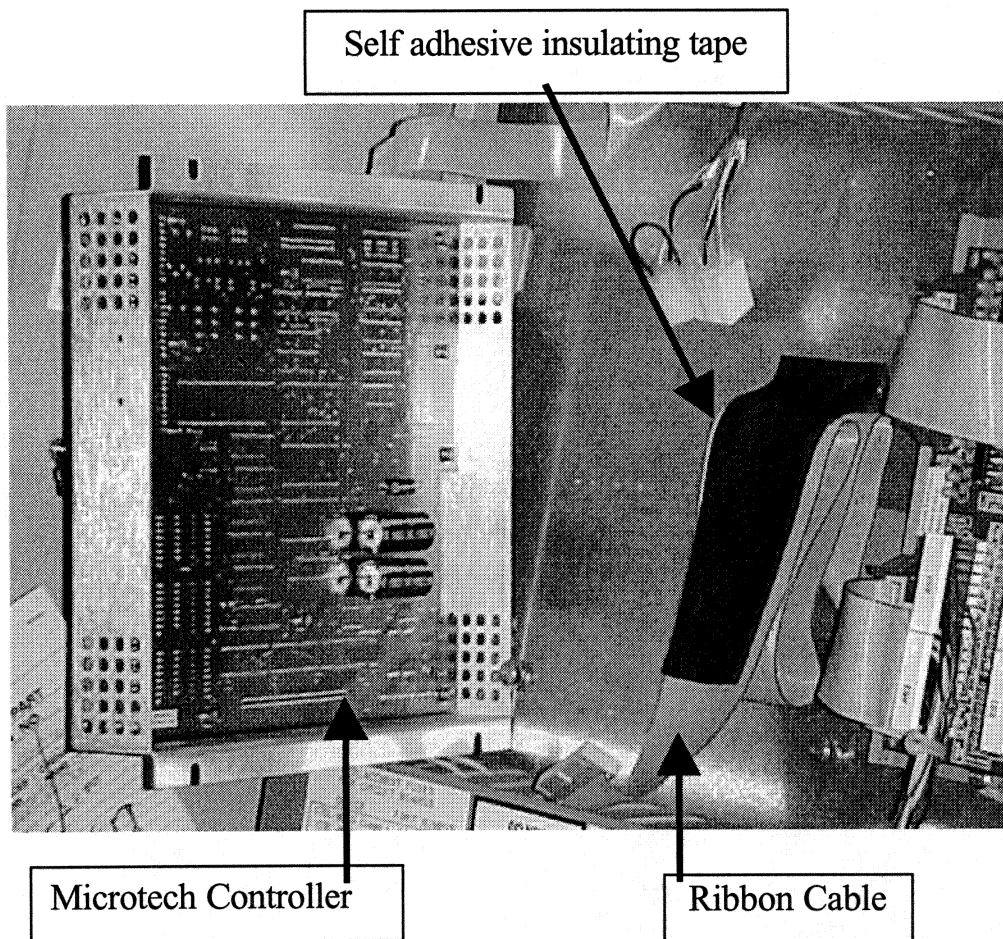



AUSTIN • CARROLLTON • DALLAS • FT. WORTH • SAN ANTONIO

McQuay Software Passwords

Monitor Programs (older)

80018002 Level 2

ffffff Level 4

86672775 Level 1

85760430 Level 3

OPM Password

**User - McQuay
Password - SGC**

WMonitor

**User - User1
Password - User1**

or

**User - User1
Password - MI**

BacNet

Password - BACdrop!