

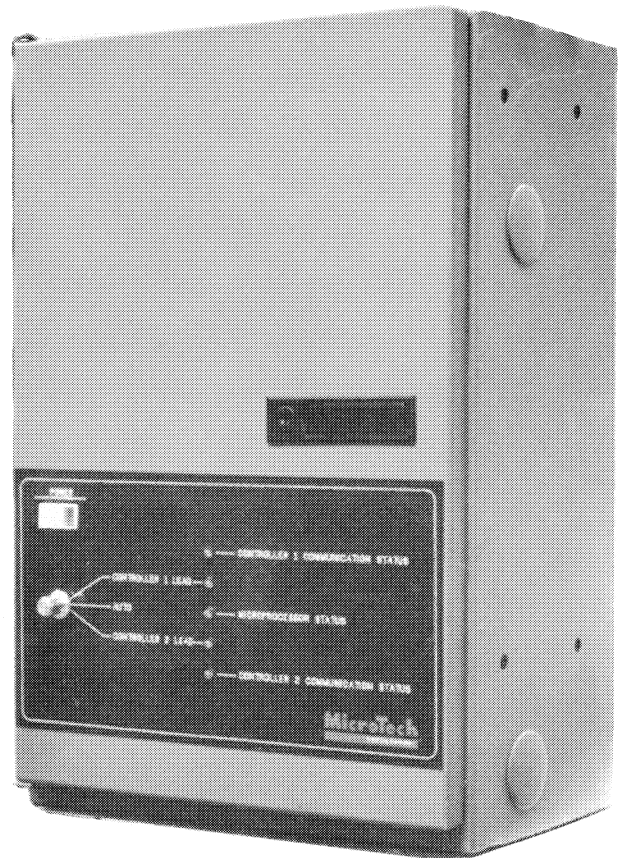

# Installation and Maintenance Data

Bulletin No. IM 425-2  
December 1990  
Form No. 553462Y

## MicroTech™ Lead-Lag/Load Balance (LLLB) System Controller

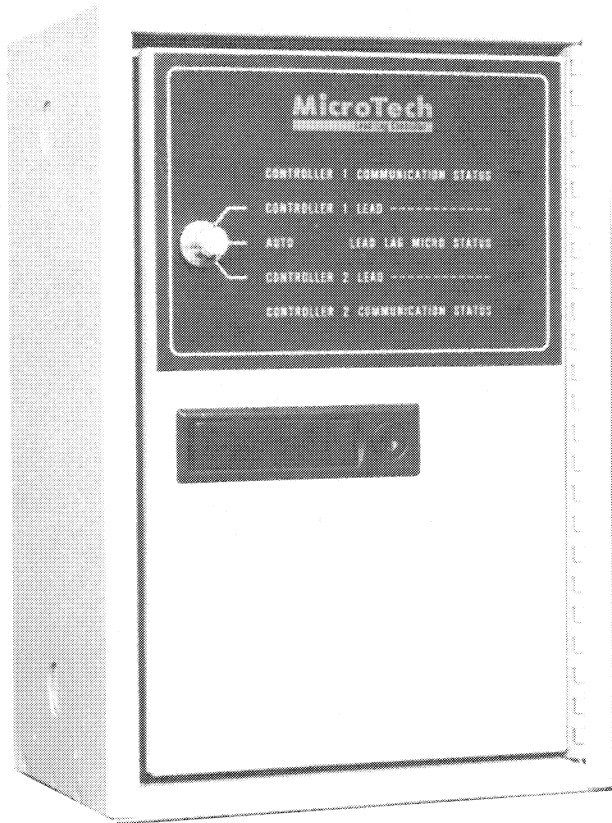

# CONTENTS

<p>Software Version Code Information . . . . . 2</p> <p>General Description</p> <p style="padding-left: 20px;">Dual (PFH) and Two Unit (2×PEH) Applications . . . 3</p> <p style="padding-left: 20px;">System Configuration . . . . . 3</p> <p style="padding-left: 20px;">Panel Configuration . . . . . 4</p> <p>Wiring</p> <p style="padding-left: 20px;">Typical Lead-Lag Wiring . . . . . 5</p> <p style="padding-left: 20px;">Field Connections and EMC Interface . . . . . 5</p> <p>LLLB Panel Programming</p> <p style="padding-left: 20px;">Chilled Water Setpoint . . . . . 6</p> <p style="padding-left: 20px;">Clock Schedule . . . . . 6</p> <p style="padding-left: 20px;">Remote Reset . . . . . 6</p> <p style="padding-left: 20px;">Remote Start/Stop . . . . . 6</p> <p style="padding-left: 20px;">Set-up Options . . . . . 6</p>	<p>Max Amp Limit . . . . . 6</p> <p>Soft Load . . . . . 6</p> <p>Hexadecimal Switch Settings . . . . . 6—7</p> <p>Initial Start-up Checks . . . . . 7</p> <p>Operation of LLLB Panel</p> <p style="padding-left: 20px;">Lead-Lag . . . . . 7</p> <p style="padding-left: 20px;">Lag Start-Stop . . . . . 7</p> <p style="padding-left: 20px;">Automatic Start-up . . . . . 7</p> <p style="padding-left: 20px;">Load Balance . . . . . 7</p> <p style="padding-left: 20px;">LLLB Panel LED Table . . . . . 8</p> <p>Service</p> <p style="padding-left: 20px;">Test Procedures . . . . . 8</p> <p style="padding-left: 20px;">LLLB Panel Voltage Readings . . . . . 8</p> <p style="padding-left: 20px;">LLLB Internal Wiring . . . . . 9—12</p>
---	--

**NOTE: Installation and maintenance are to be performed only by qualified personnel who are familiar with local codes and regulations, and are experienced with this type of equipment. CAUTION: Sharp edges are a potential injury hazard. Avoid contact with them.**

## SOFTWARE VERSION NUMBER CODE INFORMATION

McQuay Engineering periodically makes improvements to MicroTech software. Each improvement is identified by a version number and revision letter, with each new revision incorporating all previous improvements. These software changes usually provide for smoother internal operation or increased customer convenience, and occasionally correct a problem in machine operation.

On any two chillers, on the same installation using separate

lead-lag/load balance control, or on any dual compressor chiller, the software version in the Display EnGinn and logic cartridge of both MicroTech panels and in the lead-lag/load balance controller must be same number.

In addition, whenever inquiries are made, or programmable components replaced, the version number must be furnished to McQuay. Version number codes for the three basic components are shown below.

**DISPLAY ENGINN CODE:**

(Found on the label attached to the upper right-hand side of the display EnGinn, MicroTech panel.)

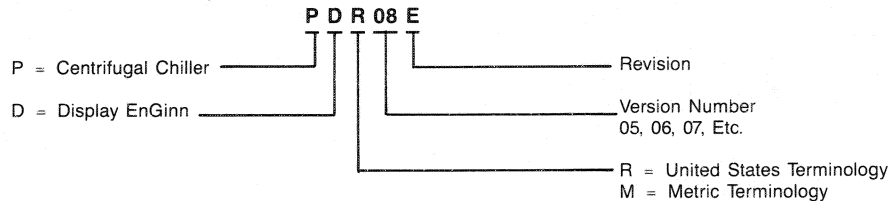

**LOGIC CARTRIDGE CODE:  
(CONTROL ENGINN)**

(Found on the label attached to the upper spine on the logic cartridge, MicroTech panel.)

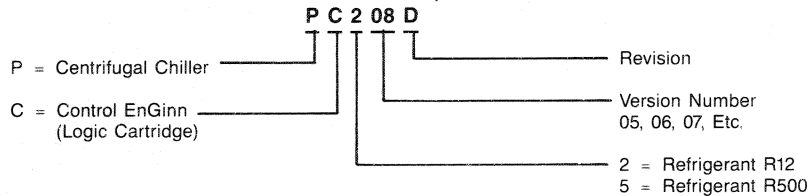

**LEAD-LAG/LOAD  
BALANCE CONTROL  
CODE:**

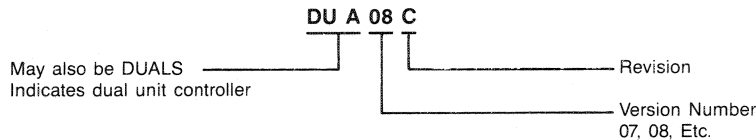

**NOTE:** The location of the LLLB control code depends on the type of control EnGinn. On the 120 EnGinn, it is located on the upper right-hand corner of the control EnGinn. On the 130 EnGinn, it is found on the upper spine of the logic cartridge.

The word "EnGinn", or "ENGINN", used in this publication is a copyrighted trademark of EnergyLine Systems L.P. and is used with permission. MicroTech is a copyrighted trademark of SnyderGeneral Corporation, Minneapolis, MN.  
© 1990 SnyderGeneral Corporation. All rights reserved throughout the world.

# GENERAL DESCRIPTION

## DUAL (PFH) AND TWO UNIT (2 × PEH) APPLICATIONS

### LEAD-LAG/LOAD BALANCE (LLL)B

The lead-lag/load balance (LLL)B control is a special purpose computer. It is designed to interact with two separate MicroTech unit panels for maximum control efficiency. Through a simple twisted pair wiring connection between the wall, or unit mounted, controller, and two MicroTech unit panels, the computer designates the lead chiller, directs the lag machine to start and stop in response to pre-determined operating conditions, and causes the machines to operate at approximately equal percent of RLA when both units are operating.

Since the LLLB controller has no display or keypad, the primary start/stop protective control function remains with each individual MicroTech unit panel. For this reason, each MicroTech unit panel must be programmed entirely; and at equal values of temperature, reset and clock scheduling. The single difference between the two MicroTech unit control panels should be the hex switch settings of the display EnGinn (see LLLB programming information on page 6).

**Figure 1. MicroTech/LLL System Configuration**

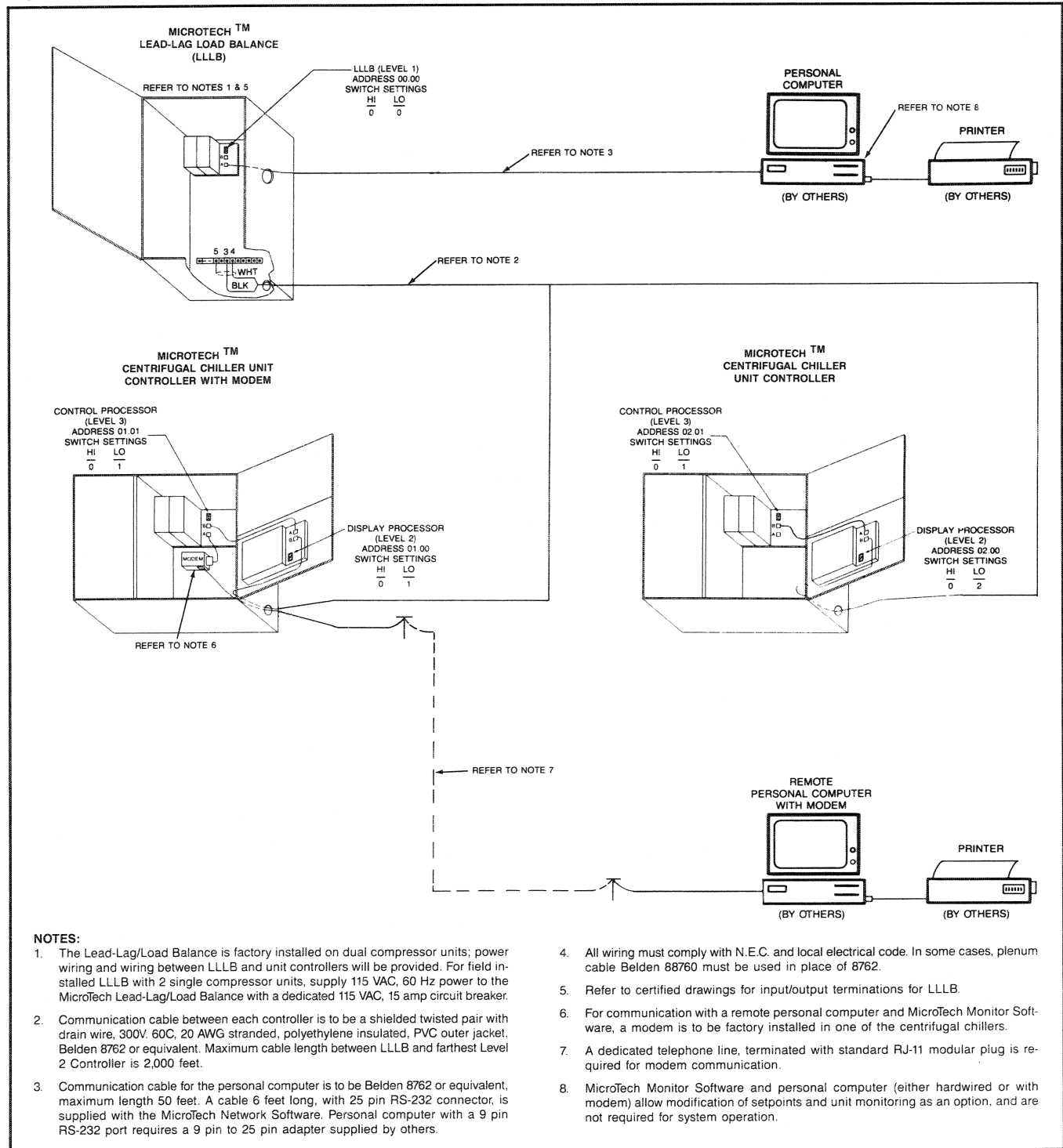

## PANEL CONFIGURATIONS

The LLLB controller panel front contains the following items:

- **LEAD-LAG/AUTO SWITCH:** The three position rotary switch is designed to be in one of two modes at all times—AUTO lead-lag or manual position of lead. With the switch positioned to AUTO, the LLLB controller will determine the correct unit to be Lead based on the total elapsed time on each MicroTech unit controller. In the manual position with controller 1 lead or controller 2 lead, the given unit will always cycle first and balance remaining cooling capacity with the other controller.
- **COMMUNICATION STATUS LIGHT:** Controller 1 and 2 each have dedicated LED lights that indicate that the twisted pair communication between each unit controller and the LLLB are in proper working condition.
- **MICROPROCESSOR STATUS LIGHT:** Blinking light that indicates the internal components (memory, communication logic, etc.) and the control program are in proper working condition.
- **CONTROLLER LEAD LIGHT:** Indicates which unit/com-

pressor is in lead.

- **POWER SWITCH:** This controls the power being fed to the LLLB panel and when "off" will disable all lead-lag/load balancing controls so each unit/compressor will operate and cycle independently.  
**NOTE:** The power switch on the front cover of some LLLB panels is omitted. The function is provided by an internal 3 amp circuit breaker switch.

The LLLB controller panel contains the following internal components:

- Microprocessor Control EnGinn: Parts on the Model 130 consist of a durable aluminum encased logic and power cartridges securely clamped to the controlling mother board.
- Terminal block for all field wiring connections.
- 115 volt to 24 volt control power transformer.
- 115 volt, 3 amp manual reset circuit breaker.

Figure 2. Panel Configurations

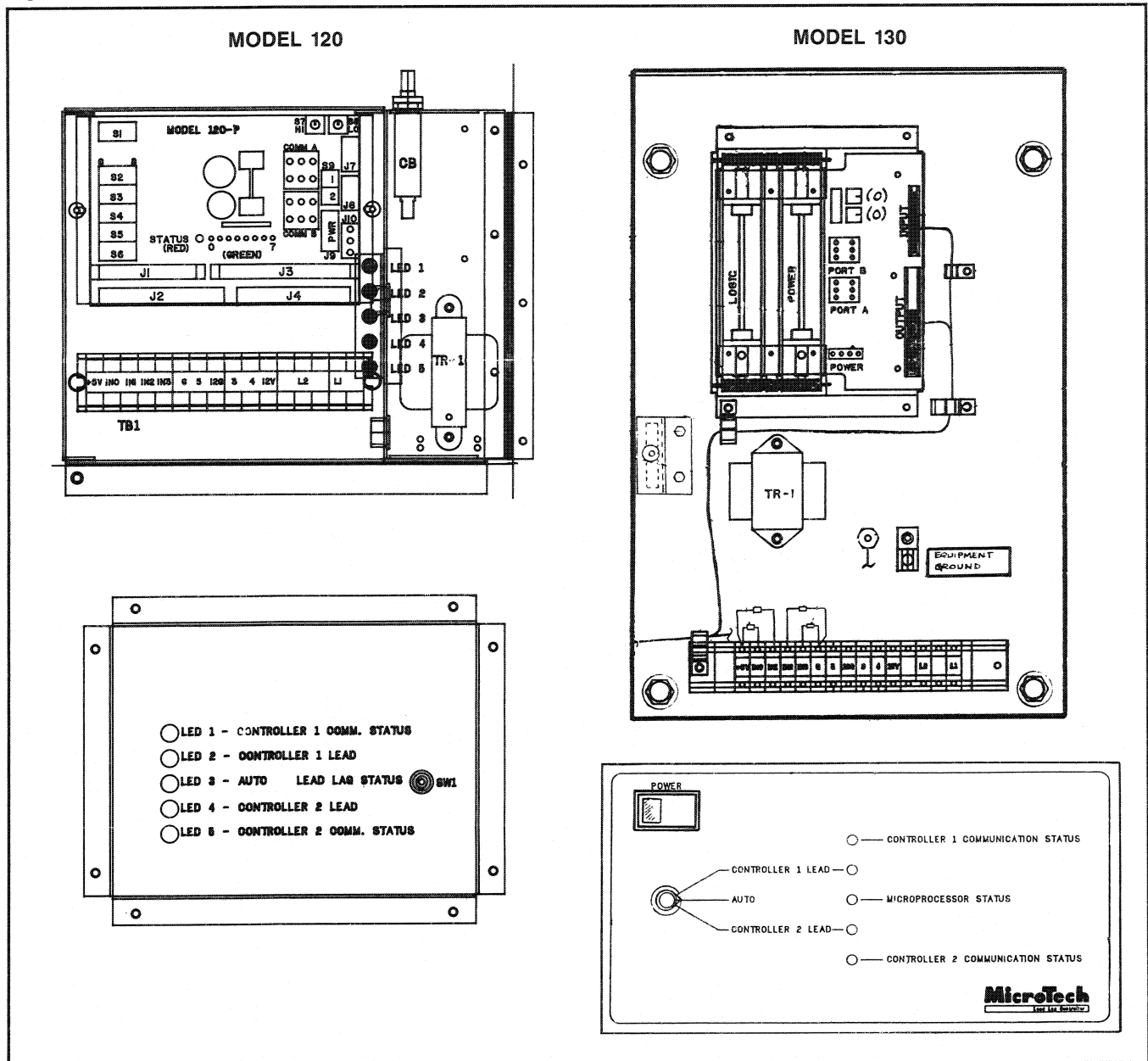

## WIRING

The contractor will mount the LLLB control panel within sight of the chillers in a reasonably accessible location. A source of 115 volt AC control power must be connected to terminals L1 and L2 inside the LLLB box. Wiring must be sized to carry not less than 5 amps. Shielded twisted pair wiring of 22 AWG minimum should be connected between the remote controller

and communications port B of the display EnGinn on each MicroTech panel.

See appropriate field connection wiring diagram for specific details.

On dual compressor PFH units, the panel will be factory mounted and the wiring complete.

**Figure 3. Typical Lead-Lag Wiring Diagram.**

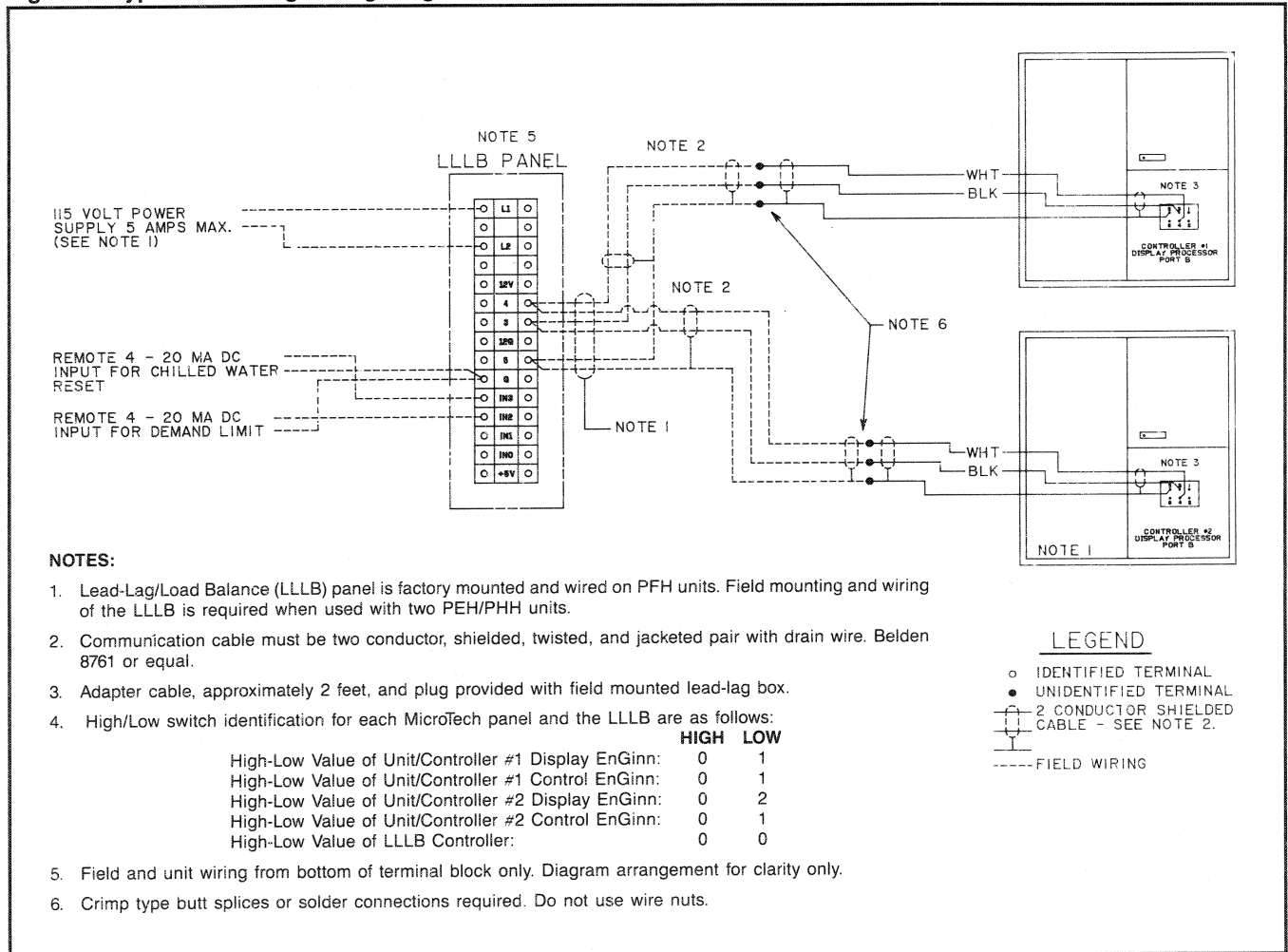

### FIELD CONNECTION AND EMC INTERFACE (REMOTE RESET CONTROL)

The LLLB controller has the capability to reset the leaving chilled water and demand limit both units/compressors by inputting a single value for each function into the LLLB controller. When the reset function(s) are to be used, the type of reset must be programmed into each individual unit/compressor controller using the "Set-up Options" key under the "Reset Options" function.

The following "Reset Options" are available with the LLLB controller:

- NONE: No reset methods or demand limiting functions are enabled.
- AMP: Remote input signal (4-20mA DC) to LLLB is to demand limit both units/compressors.
- ChW: Remote input signal (4-20mA DC) to the LLLB is

used to reset the leaving evaporator setpoint on both units/compressors.

- ENT: Reset of chilled water (return water control) shall be enabled, no EMS/BAS signal required.
- AMPENT: Remote input signal (4-20mA DC) to the LLLB is to demand limit the chiller and the reset from return water (return water control) will be enabled.
- AMPChW: Remote input signals (4-20mA DC) into the LLLB are to demand limit the chiller and reset leaving chilled water on both units.

**NOTE:** In the event remote reset of chilled water and/or electrical demand will be provided, the customer furnished 4 to 20mA signal and wiring must be connected to the LLLB box, and not to the individual MicroTech unit panels.

## LLLB PANEL PROGRAMMING

Certain values must be identically programmed into each individual unit/compressor controller to allow the LLLB controller to function properly. The following is the list of values that must be entered into each unit/compressor controller:

1. **Leaving Chilled Water Setpoint** — Must be set for the same value in each unit.
2. **Clock Schedule** — Must be set identically. If no clock schedule is desired, the clock in each unit must be turned "ON" by setting "S1 First Day=SUN" in both units.
3. **Remote Reset (Demand Limit/Chilled Water Reset)** — Must be entered into both unit/compressor controllers if this feature is to be activated.
4. **Remote Start/Stop** — Must have a set of dry contacts or a jumper installed between terminals 9 and 64 on each unit/compressor controller. In addition each controller must be programmed for "REMOTE" start/stop.
5. **Set-Up Options** — Must be programmed identically in both units. The exact value will vary according to actual job conditions. The variables associated with the LLLB controller are:
  - **ENABLE/RLA** — This is the percentage of Rated Load Amps (RLA) the lead chiller/compressor must be at or above before the lag chiller/compressor is brought on-line. The factory setting is 95% and is adjustable from 80 to 100%.
  - **DISABLE/RLA** — This is the percentage of Rated Load Amps (RLA) both chillers/compressors must be at or below before the lag chiller/compressor is cycled off (lag chiller is the unit/compressor with the highest elapsed hours of operation when the selector switch is in the "Auto" position). The factory setting is 45% and is adjustable from 35 to 60%.
  - **TIME DELAY** — This is the elapsed time the unit(s) % RLA must be at or above the ENABLE % RLA or at or below DISABLE % RLA setpoints before a unit is started or stopped, respectively. The factory setting is 5 minutes and is adjustable from 1 to 10 minutes. The lead unit/compressor, for example, must be at or above 95% RLA for 5 minutes before the lag unit/compressor is started.
6. **Max Amp Limit** — Must be set for 100% in each unit/compressor controller. If the "Max Amp Limit" is set for something other than 100% in either unit/compressor controller neither unit/compressor will load beyond that setting when both are running.
7. **Soft Load** — Will be ignored by version "08" software revisions A, B and C if it is entered into either or both

unit/compressor controllers. On installations using version "07" software it is not recommended that the "Soft Load" feature be activated.

8. **Hexadecimal Switch Settings** — Must be set in accordance with the values listed in Table 1 to correctly address each component and permit network communication.

These switches are approximately 1/2" square, with an arrow shaped screwdriver slot in the center face. Around the perimeter of the adjusting screw, the face of the square block contains the numbers 0 through 9 and the letters A through F. The switches as shown in Figure 4 are located in the following locations:

- Unit/Compressor Controller has two (2) sets of switches, one on the Control EnGinn and one on the Display EnGinn. The Control EnGinn switches are located on the upper right-hand corner portion of the mother board. The Display EnGinn switches are found on the back side of the 20 character display in the lower right-hand corner.
- LLLB controller has one set of switches located on the upper right-hand corner of the Model 120 EnGinn or on the upper right portion of the LLLB panel mother board for the Model 130 EnGinn.

Next to or above each switch, on the mounting panel, lettering will identify the switches as "HI" or "LO". Do not assume the "HI" or "LO" from their physical position.

**NOTE:** For detailed explanation of how to input the values listed above, refer to the MicroTech Unit Controller Installation and Operation Data Bulletin No. 403.

9. **DIP Switch Settings** — On the Model 120 EnGinn must be set as shown in Figure 4. These switches are approximately 1/4" by 1" with 8 numbered switches across the face. On the left side there is an arrow indicating the "on" position. The Model 120 EnGinn has six sets of DIP switches located on the left-hand side of the EnGinn.
10. **Communications Port Switches** — On the Model 120 EnGinn must also be set as shown in Figure 4.

**IMPORTANT!** Switches may or may not be factory set. In any case, verify that all switches are correctly positioned. If it is necessary to change any switch settings, the panel must be powered down, then re-energized, to input the new settings into microprocessor memory. This can be most readily accomplished by tripping, then resetting, the 3 amp circuit breaker; or tripping the power switch "off" depending on the style of the unit.

**Table 1. Hexadecimal Switch Settings**

HEXADECIMAL SWITCH	SINGLE UNIT INSTALLATION CONTROL AND DISPLAY ENGINN	TWO UNIT INSTALLATION OR DUAL COMPRESSOR UNIT WITH LEAD-LAG/LOAD BALANCE				LEAD-LAG PANEL
		#1 COMPRESSOR OR UNIT		#2 COMPRESSOR OR UNIT		
		CONTROL ENGINN	DISPLAY ENGINN	CONTROL ENGINN	DISPLAY ENGINN	
"LO" SWITCH	1	1	1	1	2	0
"HI" SWITCH	0	0	0	0	0	0

\*Arbitrarily select one of the units to be "Number 2".

Figure 4. Lead-Lag/Load Balance Switch Settings (Model 120)

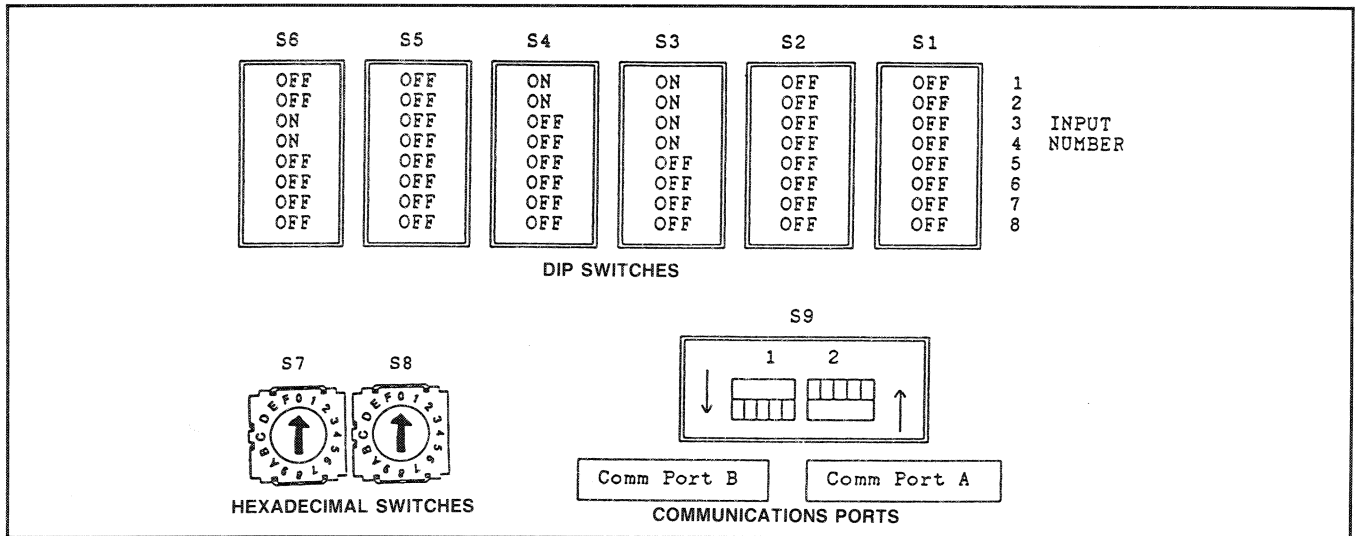

## INITIAL START-UP CHECKS FOR TWO UNIT INSTALLATIONS OR DUAL COMPRESSOR UNITS

The procedures listed in this bulletin are not intended to be a substitute for the procedures published in MicroTech Unit Controller Bulletin, IM No. 403. Prior to power being applied to the unit(s) compressors all checks listed in IM No. 403 must be completed on each individual unit/compressor controller before operation of the LLLB controller is attempted.

The following items should be checked per LLLB programming instructions before applying power to the LLLB panel:

- Leaving Chilled Water Setpoint
- Clock Scheduled
- Remote Reset (Demand Limit/Chilled Water Reset)
- Remote Start/Stop
- Set-Up Options
- Max Amp Limit
- Soft Load
- Hexadecimal Switch Settings
- DIP Switch Settings (Model 120)

Once all of the programming has been verified apply power to the LLLB panel and verify correct operation per the "Operation" instructions.

## OPERATION OF THE LEAD-LAG/LOAD BALANCE PANEL

**LEAD-LAG** — A three-position switch on the front cover panel is marked:

- Controller (Number) 1 Lead
- Auto Lead, (and)
- Controller (Number) 2 Lead

If the switch is positioned to either controller 1 or controller 2, that unit will be the lead unit and the other the lag.

If the switch is positioned for Auto Lead, the computer will read the operating hours of the two machines and select the one with the least operating hours to be the lead. A change from one lead to the other will only occur when both units are off, or both are operating. In this manner the units are protected against a sudden switch in the lead unit selection as the hours of the operating machine overtake the operating hours of the other (off) machine.

**LAG START-STOP** — The lead machine increases its capability to satisfy an increasing cooling load. When this compressor's maximum capacity is approached, at a pre-set value input under the "Set-up Options" key, the signal is communicated to the lag machine to start and run. The operating signal is "Enable Lag" and it is set based on the percentage of the Lead units operating amps. The Enable Lag cannot be set for less than 80%, nor more than 100%. A normal recommended setpoint is 95%. Further, the lag machine will not

start immediately when the % amps reaches the setpoint. A "Delay Timer" setpoint requires that the % amps consumed equal or exceed the setpoint % amps for the period of time programmed. In this manner, unnecessary cycling is avoided.

A third setpoint, "Disable Lag = XX%" also requires setting. This too is a % of the lead compressor's operating amps. The value may be set anywhere between 35% to 60%. A recommended value is 40%. Here too, the "Delay Timer" setpoint will require that the lead compressors operating amps be equal or less than the setpoint value for the programmed "Delay" time.

Because either compressor can be the "Lead" unit, the three values must be set the same in each MicroTech chiller panel.

### AUTOMATIC START UP

If the lead compressor has shutdown and is inoperative because of a fault, the LLLB controller will automatically start the other machine. No operator changeover is required.

### LOAD BALANCE

When both units, or compressors, are operating, the controller unloads, the compressor drawing the greatest % of amps until the % of amps drawn by both are within 5% of each other.

At any given load, as the one compressor is unloaded, the second is loaded to achieve the balance and satisfy the setpoint water temperature.

**Table 2. LLLB/Unit Controller LED's**

LED DESIGNATION	LED LOCATION	STATUS INDICATION
#1 COMMUN STATUS	LLLb PANEL FRONT	On solid if communication to unit controller #1 is in proper working condition. Something other than a solid LED indicates a communication problem to that unit.
#2 COMMUN STATUS	LLLb PANEL FRONT	On solid if communication to unit controller #2 is in proper working condition. Something other than a solid LED indicates a communication problem to that unit.
#1 & #2 CONTROLLER LEAD	LLLb PANEL FRONT	Will be lit to indicate which unit/compressor is in the lead position with the selector switch in the "AUTO" position. Will also be lit to show which unit is "MANUALLY" in the lead position via the selector switch.
MICROPROCESSOR STATUS	LLLb PANEL FRONT AND EACH INDIVIDUAL UNIT CONTROLLER PANEL FRONT	Blinking if internal control program is functioning properly. Something other than a blinking LED indicates an internal control program failure.
POWER CARTRIDGE (MODEL 130 ENGINN, LLLB)	ON THE POWER CARTRIDGE PLUGGED INTO THE MOTHER BOARD OF BOTH THE LLLb PANEL AND EACH UNIT/COMPRESSOR CONTROLLER.	Blinking in the same manner as the microprocessor status LED. It will also indicate a correctly functioning internal control program.
DISPLAY ENGINN	ON THE BACKSIDE OF THE 20 CHARACTER DISPLAY ENGINN	Blinking in the same manner as the microprocessor status LED. It also indicates that the internal control program is functioning correctly.

## SERVICE

The trouble analysis procedures listed in this section pertain primarily to the LLLB controller. For a detailed trouble analysis of individual unit/compressor controllers refer to the "Service" section of IM #403.

**NOTE:** Some differences in service and trouble analysis procedure exist between the Model 120 and Model 130 LLLB control EnGinns. When a particular procedure or operation check applies to a specific model, the model number will be shown in parentheses.

**CAUTION!** The McQuay MicroTech control panel contains components which may be damaged if subjected to static discharge. To prevent such damage during service involving board replacement, McQuay recommends dissipating any static electrical charge by touching the bare metal inside the panel before performing any service work.

If the failure is in fact in the LLLB controller each individual unit/compressor will continue to operate as a independent unit; only the lead-lag/load balance feature will fail to function.

Prior to analyzing any problem on a LLLB controller, first verify that all LLLB program variables are set according to the instructions on page 6. If all variables are not correctly set, correct them and restart the controller. With the LLLB controller powered up, re-check operation to see if the problem still exists.

All of the following assumes that the power is applied to the LLLB controller and the associated unit/compressor controllers.

Where the following procedures describe the removal and/or replacement of any wires, connectors or components always shut off power to the panel before making the disconnect or replacement. Also, before engaging in any trouble-shooting procedures, any external connections to terminals IN2 and IN3 on the field wiring strip should be disconnected. This will prevent any external interference to the proper operation of the unit.

- If the "Microprocessor Status" LED is out:
  - Check the power supply: 12 VAC for Model 130, 9 VAC for Model 120.
  - (Model 130) Check for 5 VDC leaving the mother board (terminal +5V on terminal strip or line 917). If voltage is less than 5 VDC, the problem is in the mother board or the power cartridge. Substitute a new power cartridge for testing before replacing mother board. If voltages check out correctly, then replace the logic cartridge.
  - (Model 120) Check 5 VDC leaving controller (line 917, or pin 12 on controller output terminal). If voltage is less than 5 VDC, replace controller.
- If the "Communications Status" LED is out:
  - Check for unit/compressor control failure.

- Check the hex switch settings.
  - Check the program version numbers on the following components: LLLB logic cartridge, unit controller logic cartridge, unit controller Display EnGinn. All of the version numbers must be the same NUMBER; if not, replace the software with the correct version.
  - Check the twisted pair communications wires for correct pin connection, proper port termination and open/shorted leads. Also be sure that the twisted pair is not run in the same conduit as voltage carrying wire.
- If the "Controller 1—2 Lead" LED is not lit:
    - Check for voltage at SW2 per Table 3; if the readings do not agree replace SW2.
 

**NOTE:** If the SW2 selector switch is moved when only one unit/compressor is in operation, the controller will not switch the lead unit/compressor until both units are "ON" or "OFF."

**Table 3. Voltage Readings For Proper LLLB Operation**

READING LOCATION		VOLTAGE		COMMENTS
STRIP NO.	TERM. NO.	MODEL 120	MODEL 130	
FIELD WIRING	IN0	5VDC	5VDC	SW2 Auto Position
	IN1	5VDC	5VDC	
	IN0	0VDC	0VDC	SW2 #1 Lead Position
	IN1	5VDC	5VDC	
	IN0	5VDC	5VDC	SW2 #2 Lead Position
	IN1	0VDC	0VDC	
	12V		12VAC	TR-1 OK
	Line 912	9VAC		
	Line 919	9VAC		TR-1 OK
J4	1	5VDC	5VDC	#1 Lead Light OFF
	Line 900	<1VDC	<1VDC	#1 Lead Light ON
	2	5VDC	5VDC	#2 Lead Light OFF
	Line 901	<1VDC	<1VDC	#2 Lead Light ON
	3	<1VDC	<1VDC	#1 Communication Status OK
	Line 902	<1VDC	<1VDC	
	4	<1VDC	<1VDC	#2 Communication Status OK
Line 903	<1VDC	<1VDC		
	5	0-5 VDC Pulse	0-5 VDC Pulse	Microprocessor Status OK
	Line 904			
	12	5VDC	5VDC	Output Voltage From Controller OK
	Line 917			
J2	1	5VDC		0 Volts if SW2 is set at Controller #2 Lead
	2	5VDC		0 Volts if SW2 is set at Controller #1 Lead

**NOTE:** All voltage readings are taken with respect to equipment ground.

Figure 5. LLLB Internal Wiring — Model 120

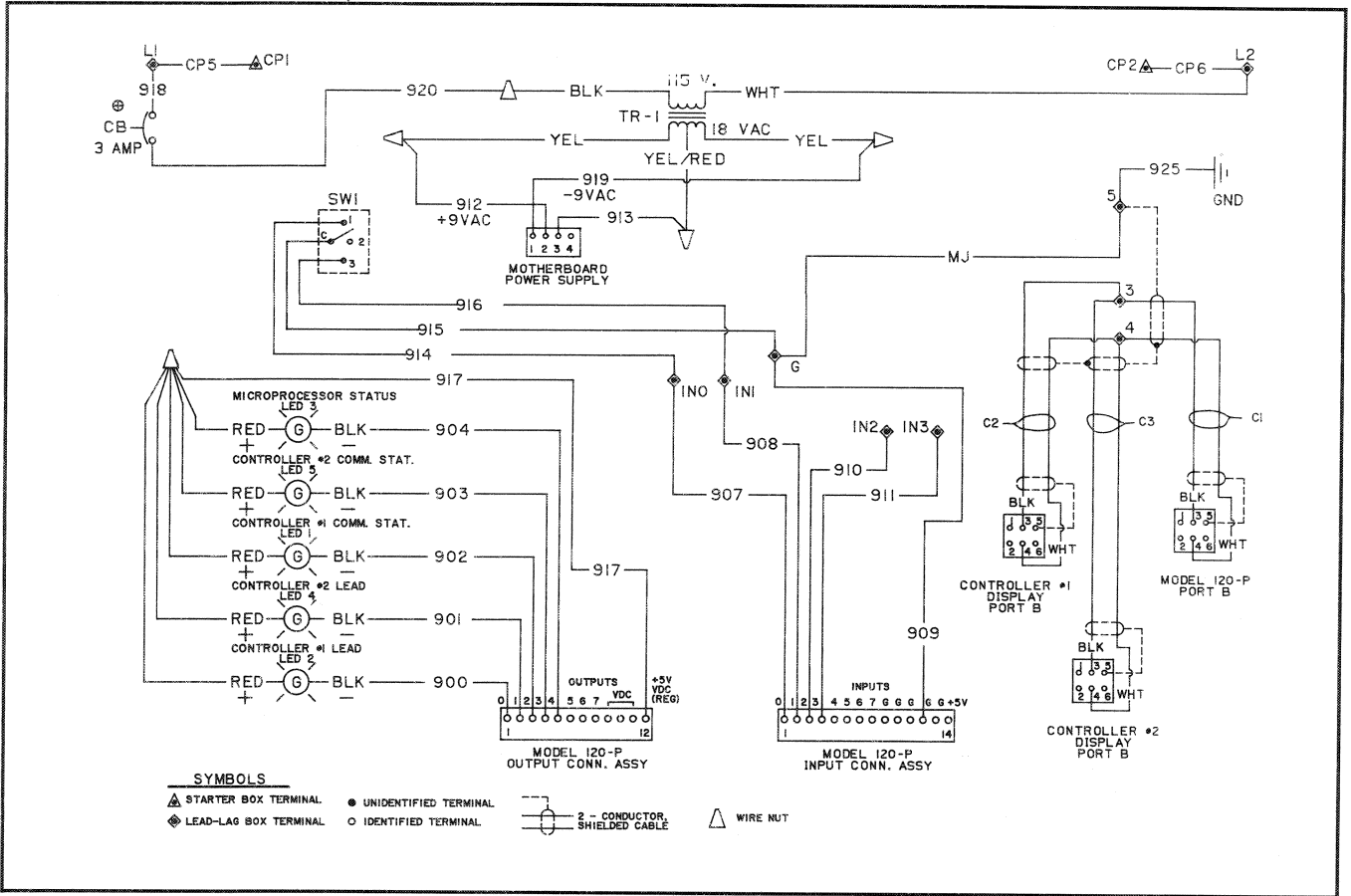

Figure 6. LLLB Internal Wiring — Model 130

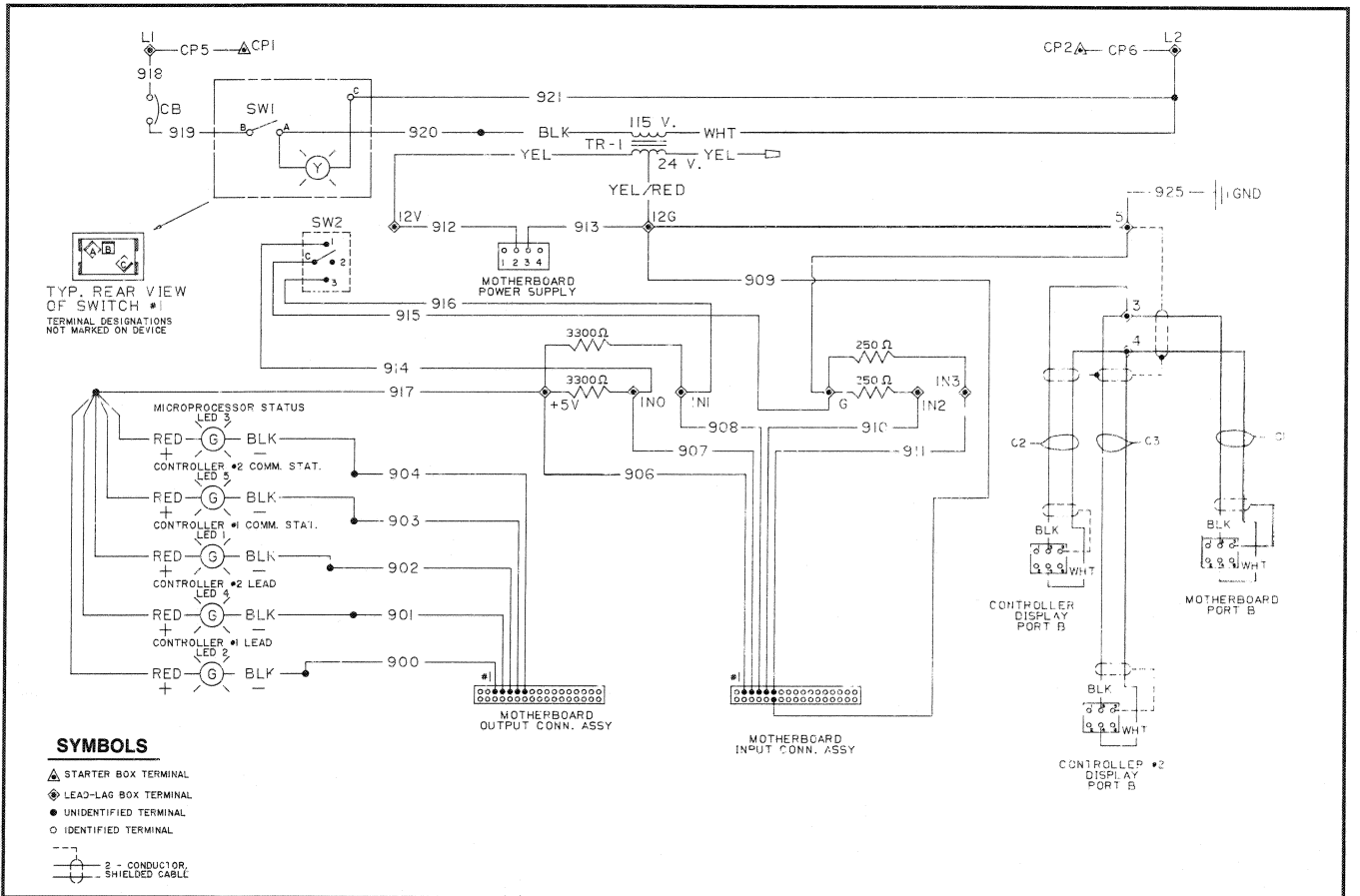
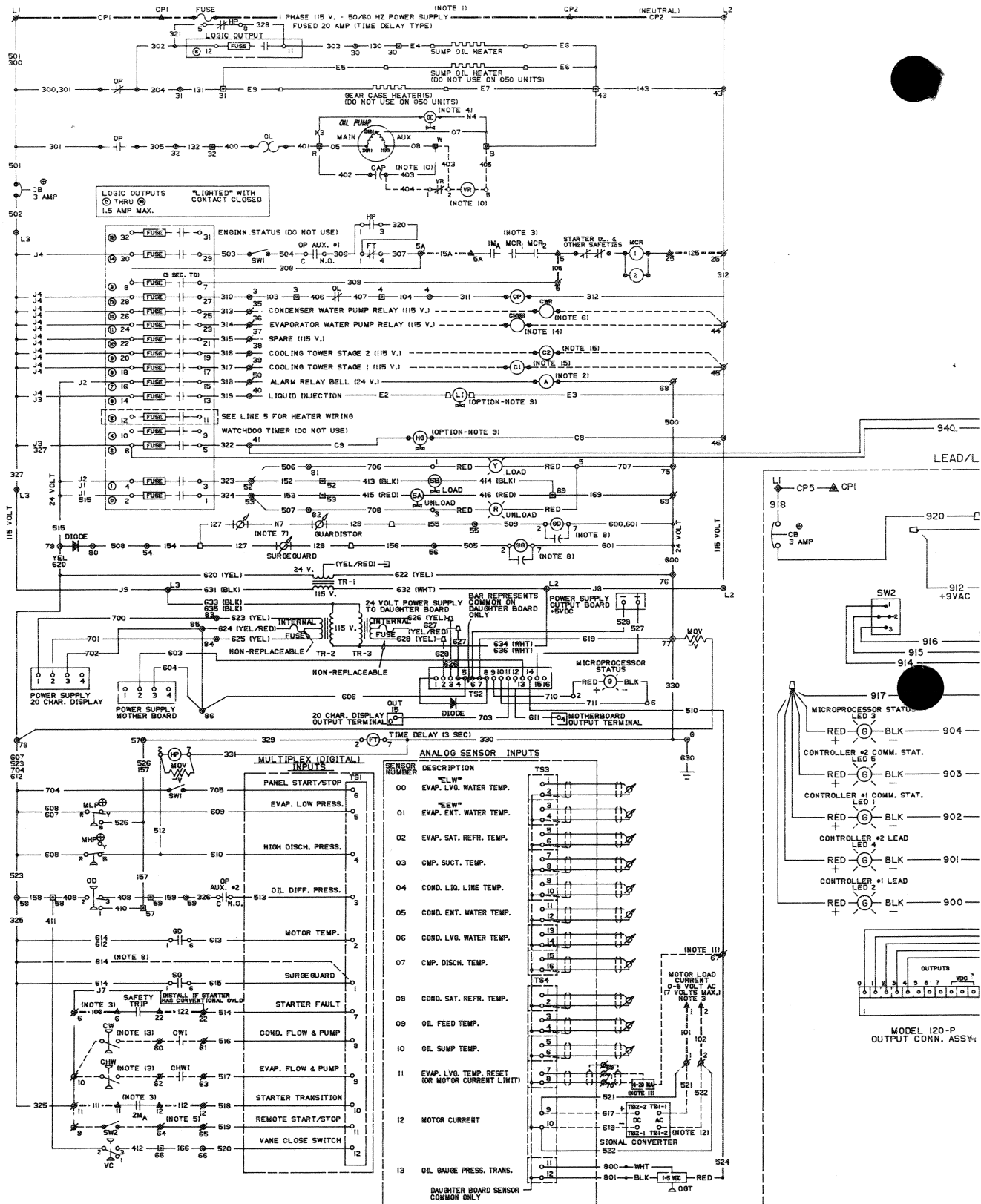

Figure 7.

CONTROLLER I UNIT

LINE CONTACT NO. LOC.

1  
2  
3  
4  
5  
6  
7  
8  
9  
10  
11  
12  
13  
14  
15  
16  
17  
18  
19  
20  
21  
22  
23  
24  
25  
26  
27  
28  
29  
30  
31  
32  
33  
34  
35  
36  
37  
38  
39  
40  
41  
42  
43  
44  
45  
46  
47  
48  
49  
50  
51  
52  
53  
54  
55  
56  
57  
58  
59  
60  
61  
62  
63  
64  
65  
66  
67  
68  
69  
70  
71  
72  
73  
74  
75  
76  
77  
78  
79  
80  
81  
82  
83  
84  
85  
86  
87  
88  
89  
90  
91  
92  
93  
94  
95  
96  
97  
98  
99  
100  
101  
102  
103  
104  
105  
106  
107  
108  
109  
110  
111  
112  
113  
114  
115  
116  
117  
118  
119  
120  
121  
122  
123  
124  
125  
126  
127  
128  
129  
130  
131  
132  
133  
134  
135  
136  
137  
138  
139  
140  
141  
142  
143  
144  
145  
146  
147  
148  
149  
150  
151  
152  
153  
154  
155  
156  
157  
158  
159  
160  
161  
162



SEE DRAWING 70610S001 FOR NOTES & LEGEND  
SEE DRAWING 70810S001 FOR FIELD CONNECTION  
DWG. NO. 706574FR01 REV. 00

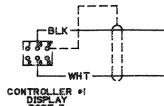

NOTE: Typical unit schematic, Model 120 shown.  
Refer to actual unit schematic for details.

CONTROLLER 2 UNIT

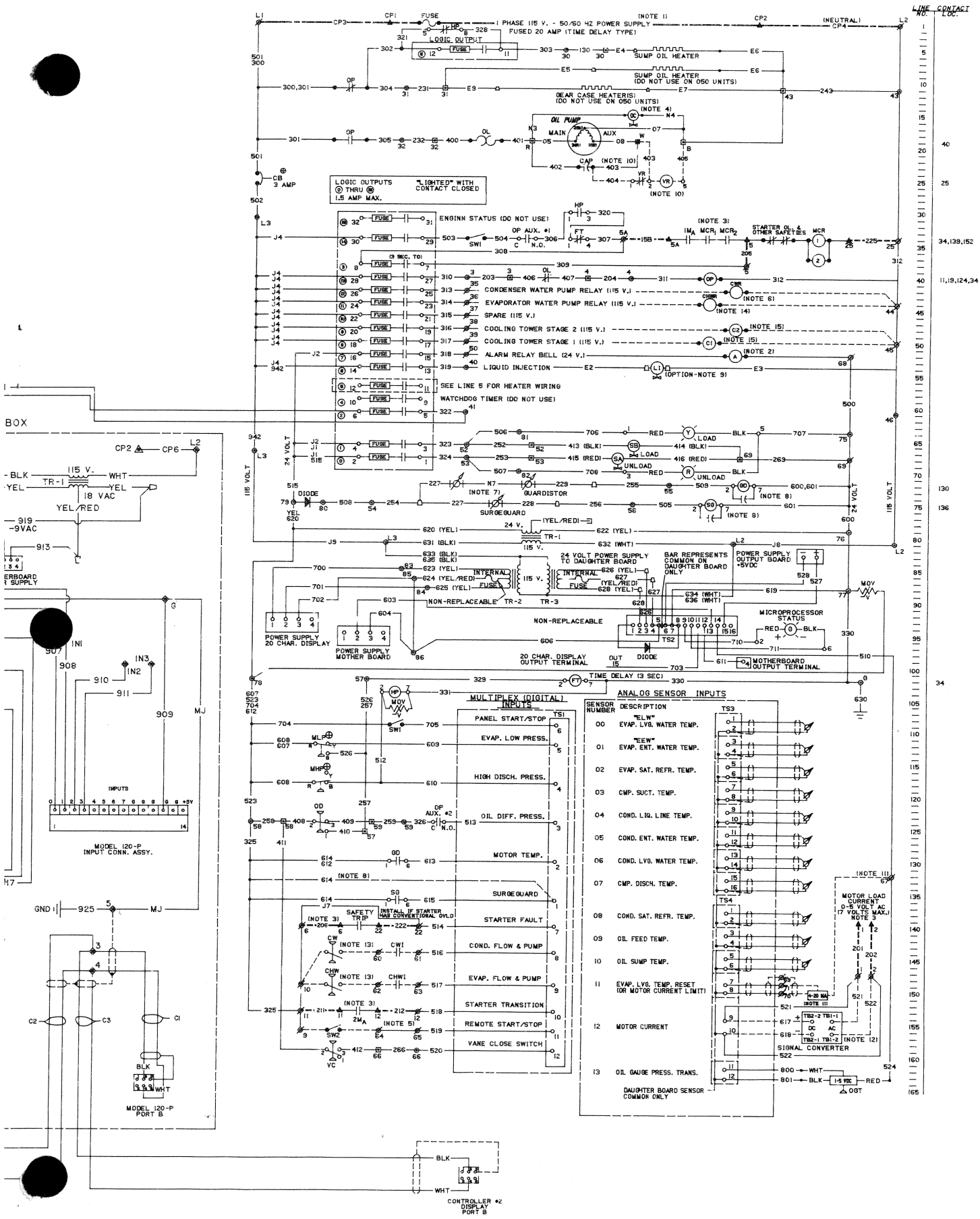

LINE CONTACT NO. LOC.

1  
5  
10  
15  
20  
25  
30  
35  
40  
45  
50  
55  
60  
65  
70  
75  
80  
85  
90  
95  
100  
105  
110  
115  
120  
125  
130  
135  
140  
145  
150  
155  
160  
165















**Figure 8. Legend—Symbols and Wiring Schematic Notes (Dwg. No. 706105C-01)**

**LEGEND**

A	ALARM, RELAY COIL
CAP	CAPACITOR
CB	CIRCUIT BREAKER
CHW	EVAPORATOR FLOW SWITCH
CHWI	EVAPORATOR WATER INTERLOCKS
CHWR	EVAPORATOR WATER RELAY
CW	CONDENSER FLOW SWITCH
CWI	CONDENSER WATER INTERLOCKS
CWR	COND. PUMP CYCLING RELAY
C1	COOLING TOWER FAN RELAY (STAGE 1)
C2	COOLING TOWER FAN RELAY (STAGE 1)
G	LIGHT (GREEN), MICRO STATUS
FT	FAULT RELAY
GD	GUARDISTOR RELAY
HG	HOT GAS SOLENOID
LI	LIQUID INJECTION SOLENOID
MHP	MECHANICAL HIGH PRESSURE SWITCH
MLP	MECHANICAL LOW PRESSURE SWITCH
M <sub>A</sub>	CONTACTOR AUXILLARY
MCR	MTR. CONTR. RELAY (STARTER)
OC	OIL COOLER SOLENOID
OD	OIL PRESS. DIFFERENTIAL SW.
OL	OVERLOAD
OP	OIL PUMP CONTACTOR
OGT	OIL GAUGE PRESSURE TRANSDUCER
PT	PNEUMATIC PRESSURE TRANSDUCER
R	LIGHT (RED), UNLOAD
SA,SB	VANE CONTROL SOLENOIDS
SG	SURGE GUARD RELAY
SW1	PANEL START/STOP SWITCH
SW2	REMOTE START/STOP SWITCH

TR-1. TR-2. TR.3	TRANSFORMER (24 VAC CT)
TS1. TS2. TS3. TS4.	DAUGHTERBOARD CONN.
TO	TIMED OPEN CONTACTS
VC	VANE CLOSE SWITCH
VR	VOLTAGE RELAY
Y	LIGHT (YELLOW), LOAD

**TERMINAL SYMBOLS**

	CONTROL BOX TERM. FACTORY WIRING
	CONTROL BOX FIELD CONN. TERM.
	LUBE BOX TERMINAL
	STARTER TERMINAL
	LEAD/LAG TERMINAL
	UNIDENTIFIED TERMINALS
	IDENTIFIED TERMINALS
	AUTOMATIC RESET
	MANUAL RESET
	THERMISTOR
	FACTORY WIRING
	FIELD WIRING
	STARTER WIRING
	OPTIONAL WIRING
	CABLE—TWISTED, SHIELDED AND JACKETED PAIR

**NOTES**

- A separate 115 V ± 10% 60 HZ, 115 V +5% -10% 50 HZ single phase power supply is required. Fuse size requirement is 20 amp fusetrone on L1 only. L2 is a grounded neutral.
- A customer furnished 24 volt alarm relay coil may be connected between terminals 50 and 68 of the control panel. The alarm coil will de-energize when safety shut down occurs. Maximum rating of the alarm relay coil is 25 VA.
- The compressor motor starters may be free standing or factory mounted. If factory mounted, all the control wiring between the starter and the control panel is factory wired.
- Oil cooler solenoid is a factory installed option on some models. If field supplied it must be wired to terminals B and R located in the lube control box.
- Remote ON/OFF control of units for multiple unit applications can be accomplished by installing a set of dry contacts between terminals 9 and 64. If an additional point or ON/OFF control is required, remove jumper J6 from terminal 64 and 85 and install the additional set of dry contacts.
- Condenser water pump must cycle with the compressor by connecting a 115V relay coil (CWR) with a maximum rating of 25 VA between terminals 35 and 44.
- Three or four thermistors may be used depending on motor size and type.
- Surgeguard relay is not used on units employing a CE050 compressor. On these units lead 614 is routed directly from guardistor relay terminal 1 to TS1-1.
- Liquid injection solenoid (L1) and hot gas solenoid (HG) are found only on units supplied with these options.
- Voltage relay (VR) is used on units employing a CE050 compressor. On the remaining units VR leads 404 and 405 are deleted and lead 403 is routed from terminal W to the capacitor.
- A customer supplied 4-20 MA signal can be supplied for chilled water temperature reset or motor current limit reset. If the customer supplied signal requires a power supply, then a 17 VDC unregulated power supply is available at terminal 67.
- A signal converter is supplied on units where the starter is not furnished with a 0—5 VDC or 4—20 MA DC load signal. If signal is available then signal converter leads 617 and 618 are deleted and lead 521 is routed from terminal 1 to TS4—9 and lead 522 is routed from terminal 2 to TS4—10.
- Water flow protection for both the evaporator and condenser must be provided. This protection shall consist of a flow switch or differential pressure switch wired between terminals 10 and 62 for the evaporator, and 10 and 60 for the condenser. In addition each pump starter shall have a set of auxiliary contacts wired to the following terminals (Evap.—Terminals 62 and 63; Condenser—Terminals 80 and 81).
- A customer furnished 115 V evaporator water pump relay (CHWR) may be connected between terminals 36 and 44. This relay will energize anytime the control requires the evaporator water pump to be energized. The maximum rating of this coil is 25 VA.
- Condenser water temperature control can be obtained by connecting two customer furnished relays between terminals 39 and 45 for the first stage and 38 and 45 for the second stage. The maximum rating of these coils is 25 VA.