

200-Series MicroTech Control Panel

For Centrifugal Chillers

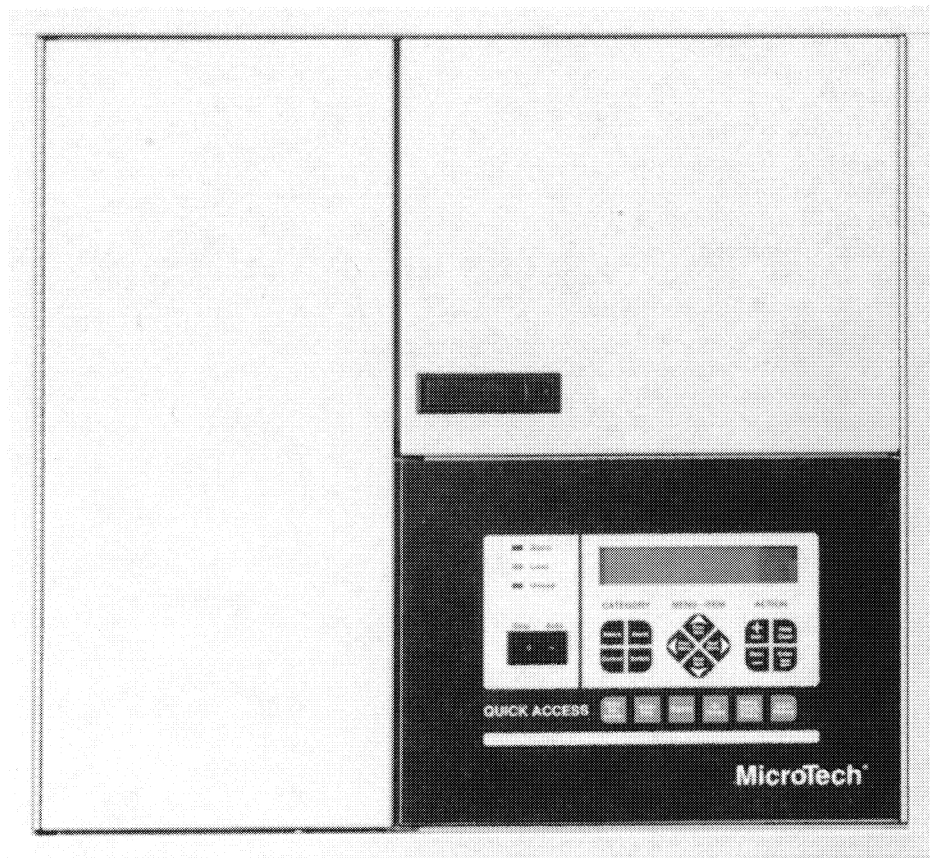

Introduction

This manual provides installation, setup and troubleshooting information for the **200 Series MicroTech** control panel for McQuay centrifugal chillers. Refer to IM 306 for Chiller installation and water piping details.

Related McQuay Documents

OM-125	Operations Manual, MicroTech for Centrifugal
IM-561	Installation Manual, IQ1000 II Motor Protection
IM-306	Installation Manual, Centrifugal Chillers
IM-618	Installation Manual, CSC Panel

All operational descriptions contained in this manual are based on MicroTech control software version PEH4E080. Chiller operating characteristics and menu selections may vary with other versions of control software. Contact McQuayService for software update information.

Installation Precautions

⚠ WARNING

Electric shock hazard. Can cause personal injury or equipment damage.

This equipment must be properly grounded. Connections to and service of the MicroTech control panel must be performed only by personnel that are knowledgeable in the operation of the equipment being controlled.

⚠ CAUTION

Static sensitive components. A static discharge while handling electronic circuit boards can cause damage to the components.

Discharge any static electrical charge by touching the bare metal inside the control panel before performing any service work. Never unplug any cables, circuit board terminal blocks, or power plugs while power is applied to the panel.

NOTICE

This equipment generates, uses and can radiate radio frequency energy and, if not installed and used in accordance with this instruction manual, may cause interference to radio communications. It has been tested and found to comply with the limits for a Class A digital device, pursuant to part 15 of the FCC rules.

These limits are designed to provide reasonable protection against harmful interference when the equipment is operated in a commercial environment.

Operation of this equipment in a residential area is likely to cause harmful interference in which case the user will be required to correct the interference at his own expense.

McQuay International Corporation disclaims any liability resulting from any interference or for the correction thereof.

Introduction	4
Installation Precautions.....	4
Temperature and Humidity Considerations	5
General Description	5
Features of the Control Panel	5
Control Panel Layout	7
Major Component Locations	7
Factory Wiring Terminals	8
Field Wiring Terminals.....	8
Component Description	9
Microprocessor Control Board (MCB1)	9
Digital Output Board	10
Analog / Digital Input Board (ADI).....	10
Analog Output Board (AOX)	11
Signal Converter Board	11
Guardistor Board	12
Power Transformers	12
Keypad / Display	12
Controller Input Signals	14
Analog Inputs	14
Digital Inputs	15
Controller Output Signals	16
Digital Outputs	16
Analog Outputs	17
Installation	18
Sensor Mounting Locations	18
Sensor Wiring.....	19
Starter Interface Wiring.....	20
Pump Control Wiring	20
Tower Control Wiring.....	22
Tower Bypass Valve.....	23
BMS Interface Wiring	23
Remote Start / Stop	22
Chiller Capacity	24
Remote Chilled Water Reset.....	24
Remote Current Limit.....	24
Audible Alarm Wiring.....	25
Network Wiring.....	26
Modem Kit.....	26
Keypad / Display Operation	27
General Description	27
Category Group.....	27
Status Key	27
Control Key.....	27
Alarm Key.....	27
Switch Key.....	26
Menu - Item Group	28
Previous Menu.....	28
Next Menu	28
Previous Item.....	28
Next Item.....	28
Action Group	29
Increment (+)	29
Decrement (-)	29
Enter (=)	29
Help / Clear.....	29
Keypad Password.....	29
Quick Access Group	30
Display Format.....	30

Pre-Start Checkout	30
Hexadecimal Switches.....	30
Powering the Control Panel	31
Software Identification.....	32
Unit Startup	33
Dry Running the Control Panel	33
Starting The Compressor	33
State diagrams	34
Safety Systems	39
Warnings.....	40
Problems	40
Faults	43
Network Operation	45
Network Configuration.....	45
Lead/Lag Load Balance Functions	45
Network Chilled Water Setpoint	45
Network Demand Limit	45
Loss of Communications	45
Unit Schematics	46

Temperature and Humidity Considerations

The MicroTech controller is designed to operate within an ambient temperature range of -40 to +149°F with a maximum relative humidity of 95% (non-condensing).

General Description

The MicroTech control panel contains a model 280 microprocessor based controller which provides all monitoring and control functions required for the safe, efficient operation of the chiller. The operator can monitor all operating conditions by using the panel's built in 4-line by 40-character keypad / display or by using an IBM compatible computer running McQuay Monitor software. In addition to providing all normal operating controls, the MicroTech controller monitors all safety devices on the unit and will take corrective action if the chiller is operating outside of its normal design conditions. If a fault condition develops, the controller will shut the system down and activate an alarm output. Important operating conditions at the time an alarm condition occurs are retained in the controller's memory to aid in troubleshooting and fault analysis.

The system is protected by a simple password scheme which only allows access by authorized personnel. A valid password must be entered into the panel keypad by the operator before any setpoints may be altered.

Features of the Control Panel

- Precise control of leaving chilled water within a $\pm 0.2^\circ\text{F}$ control band.
- Precise readout of all temperature and pressure readings:
 - entering and leaving chilled water temperature
 - entering and leaving condenser water temperature
 - saturated evaporator refrigerant temperature and pressure
 - saturated condenser temperature and pressure
 - outside air temperature
 - suction line, liquid line and discharge line temperatures
 - calculated superheat and subcooling oil sump temperature
 - oil feed temperature and pressure optional evaporator and condenser heat recovery temperature
- Automatic control of primary and secondary evaporator and condenser pumps.
- Control of up to 4 stages of cooling tower fans plus modulating bypass valve.
- Panel mounted 12 key keypad plus 6 Quick Access function keys. The operator can log chiller operating conditions from a single keypad/display instead of reading gauges, thermometers, pots, etc. The display is a backlit, 4 line by 40 character LCD type for easy viewing in all lighting conditions.
- New Auto-logging feature will automatically log chiller functions at the time of peak load or at a preset time. The controller will store and display up to six weeks of accumulated data.

- Security protection against unauthorized changing of setpoints and other control parameters.
- Complete warning and fault diagnostics to inform operators of warning and fault conditions in plain language. All warnings, problems and faults are time and date stamped so there is no guessing of when the fault condition occurred. In addition, the operating conditions that existed just prior to shutdown can be recalled to aid in isolating the cause of the problem.
- Eight previous faults and related operating conditions are available from the display.
- Soft Loading feature reduces electrical consumption and peak demand charges during loop pulldown.
- Adjustable load pull-down rate reduces undershoot during loop pulldown.
- Easy integration into building automation systems via separate 4-20mA dc signals for chilled water reset and demand limiting.
- Internal time-clock for on/off scheduling. The time clock accommodates a 7 day schedule plus holiday, 1 start and stop per day, and 14 holidays with programmable duration.
- Communications capabilities for remote monitoring, changing of setpoints, trend logging, remote reset, alarm and event detection, via IBM-PC running McQuay MicroTech (tm) software.
- Manual control mode allows the service technician to command the unit to different operating states. Useful for system checkout.
- Communication capability with most major building automation systems via McQuay Open Protocol strategy.
- Service Test mode for troubleshooting controller hardware.
- Display available in either U.S. Customary or SI units.
- Keypad programmable alarm contacts for normally open, or normally closed, and optional pulse output on problem and warning conditions.
- Pressure transducers for direct reading of system pressures.
- Preemptive control of low evaporator pressure conditions to take corrective action prior to a fault trip.
- Preemptive control of high discharge temperature.
- Modulating oil cooler valve control.
- Minimum vane position setpoint.

Control Panel Layout

Major Component Locations

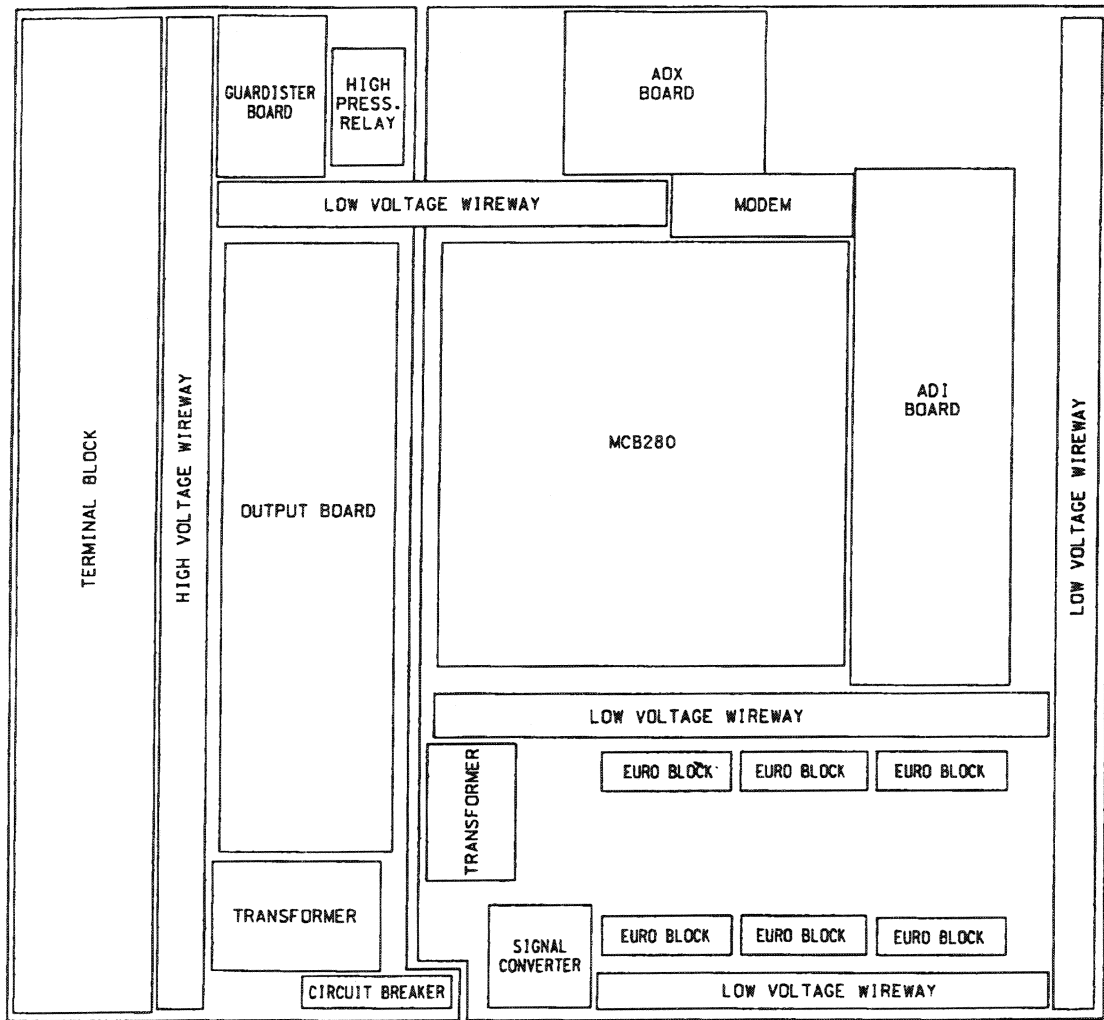

Factory Wiring Terminals

Factory wiring is terminated on a I.E.C. style terminal strip using spring loaded wire retainers. Wires may be moved by inserting a narrow screwdriver into the rectangular hole and applying lateral pressure to open the spring clamp. With the clamp held open, a wire may be inserted into the round hole adjacent the screwdriver. The spring loaded clamp will close around the wire when the screwdriver is removed.

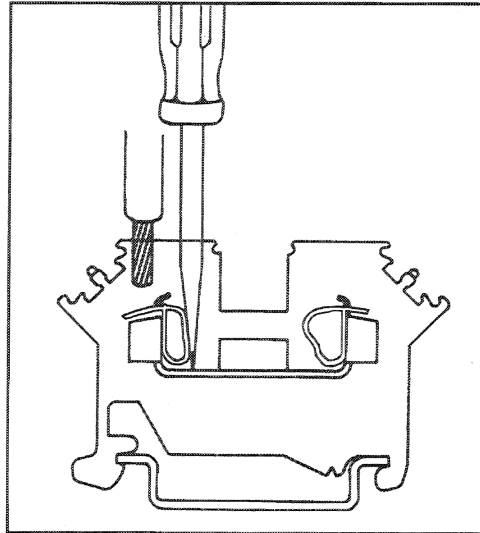

Field Wiring Terminals

All field wired sensors and reset signals are terminated on labeled, dual-screw barrier strips mounted in the bottom of the low voltage side of the cabinet. These terminal strips will accept wire sizes up to 18AWG.

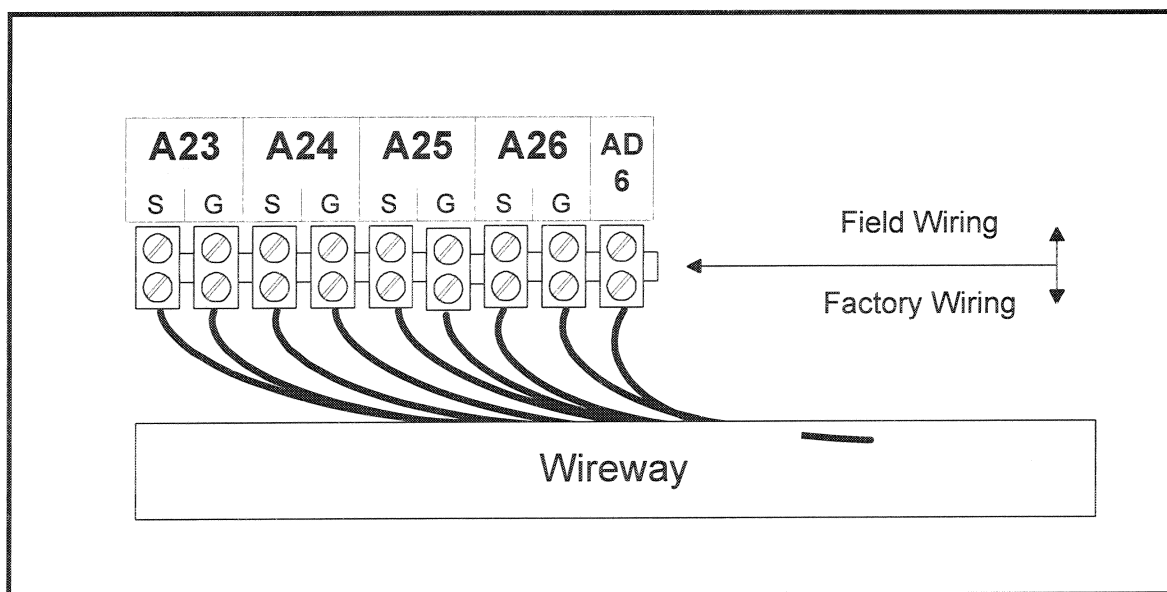

Component Description

Microprocessor Control Board (MCB1)

The Model 280 Microprocessor Control Board contains the electronic hardware and software required to monitor and control the unit. It receives input from the ADI Board and sends commands to the Output Board to maintain the unit's optimum operating mode for the current conditions. Status lights are mounted on the control board to indicate the operating condition of the microprocessor.

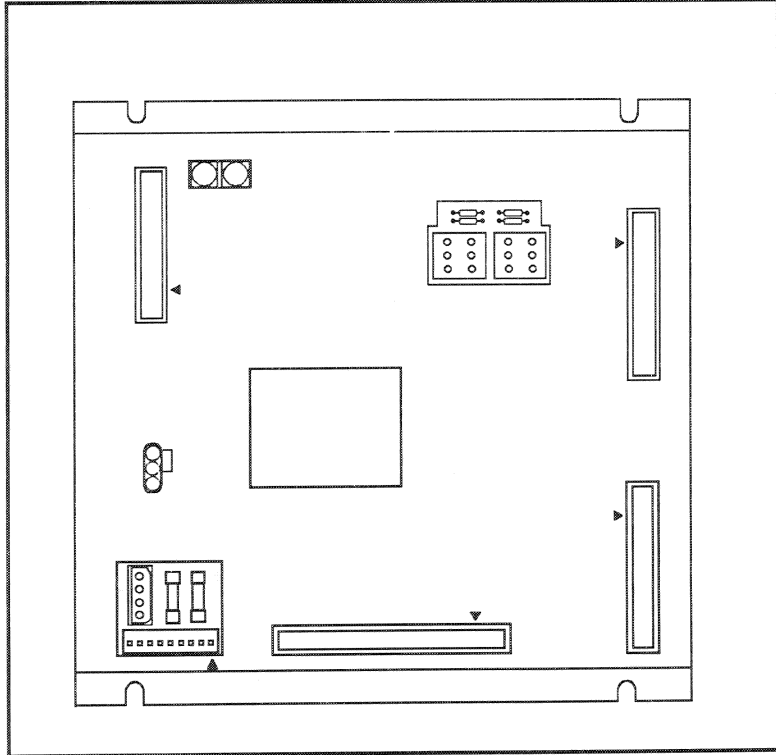

Digital Output Board

The Output Board contains up to 24 solid state relays which are used to control the compressor, cooling tower fans, solenoid valves and alarm annunciation. It receives control signals from the Microprocessor Control Board through a 50 conductor ribbon cable.

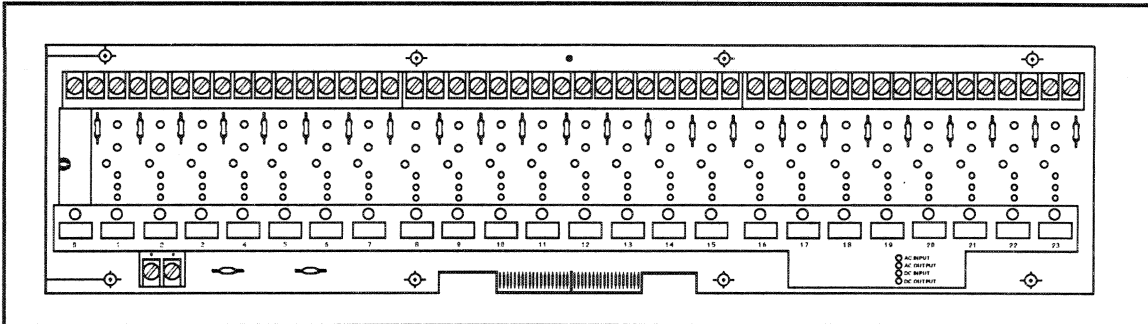

Analog / Digital Input Board (ADI)

The ADI Board provides low voltage power for the temperature and pressure sensors. It also provides optical isolation between the Microprocessor Control Board and all 24V switch inputs. LED's are furnished on the board to give a visual indication of the status of all digital inputs. All analog and digital signals from sensors, transducers and switches are received by the ADI Board and then sent to the Microprocessor Control Board for interpretation.

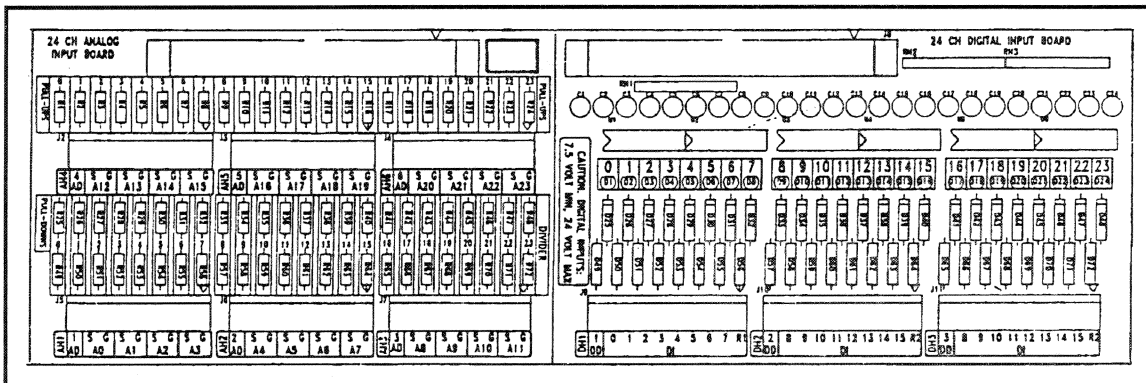

Analog Output Board (AOX)

The AOX board converts control instructions from the Microprocessor Control Board's expansion bus into an analog control signal suitable for driving a cooling tower bypass valve. Each AOX board is factory set via jumper to provide an output signal range of 0 - 10 VDC. An additional output on the AOX board provides an analog signal that is proportional to compressor motor current.

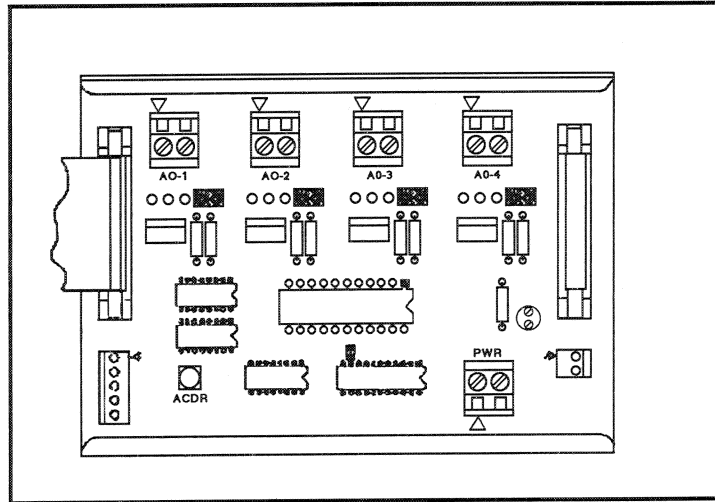

Signal Converter Board

The AC current signal generated by the starter is converted by (0 VDC=0% Amps/4 VDC=100% Amps) the signal converter board into a 0-5 VDC signal that is directly proportional to the chillers amp draw. The amp draw signal is sent to the ADI board for conditioning and then to the M280 controller.

The signal converter board is not used when a McQuay IQ1000 motor protection device is installed in the starter.

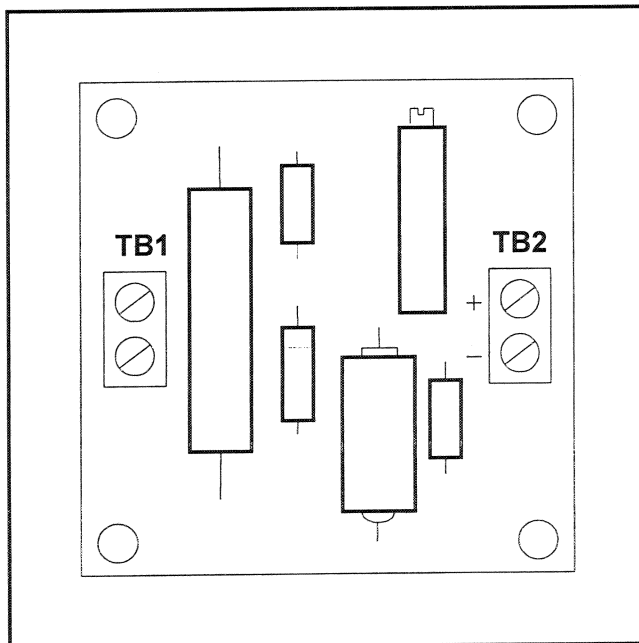

Guardistor Board

The Guardistor board monitors the motor winding temperature via the embedded Guardistor sensors. If the motor temperature rises to an unsafe level, the board will signal the M280 controller and the chiller will be shut down.

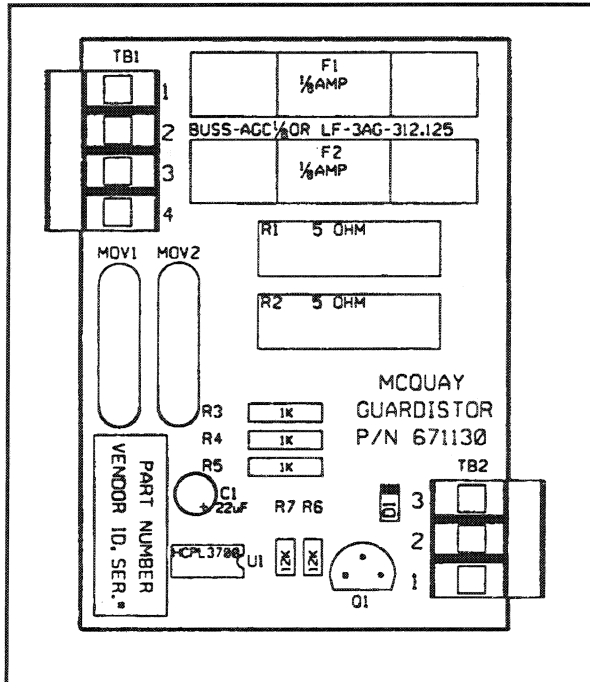

Power Transformers

Transformers T2 and T3 provide operating power to the MicroTech controller and its associated components. T2 is a conventional ferrite core transformer that converts 120VAC from the control transformer into 24VAC. T3 is a high efficiency toroidal design that converts 24VAC from T2 into a center-tapped 18VAC.

Keypad / Display

The Keypad/Display is the primary operator interface to the unit. All operating conditions, system alarms and setpoints can be monitored from this display and all adjustable setpoints can be modified from this keyboard if the operator has entered a valid operator password.

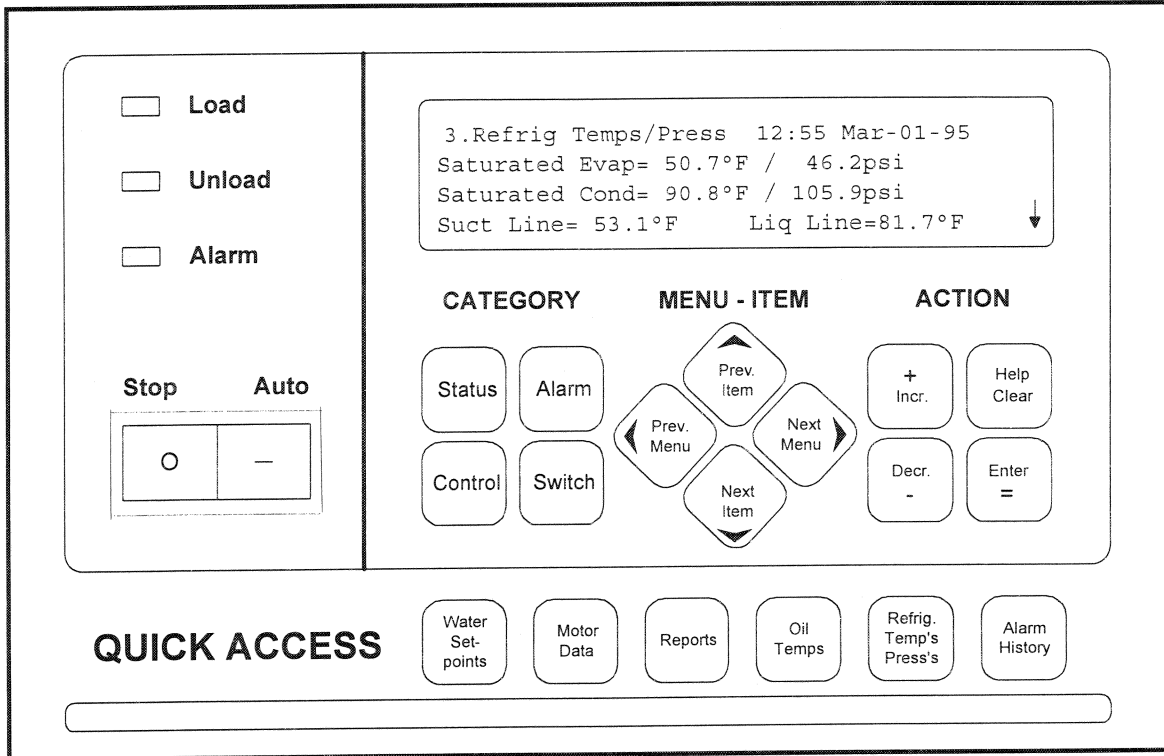

Controller Input Signals

Analog Inputs

Analog inputs arriving at the ADI board are comprised of temperature, pressure, and flow signals. In addition, the chiller control panel may receive chilled water reset and demand limit signals in the range of 4-20 mA. Temperature and pressure readings have a resolution of 0.1°F and 0.1psi respectively. Flow readings and remote reset signals are resolved to ±1%.

No.	Description	Range
0	Leaving Evaporator Water Temp	Standard Temp -40 ^o -263 ^o F
1	Entering Evaporator Water Temp	Standard Temp -40 ^o -263 ^o F
2	Compressor Suction Temp	Standard Temp -40 ^o -263 ^o F
3	4-20mA ChW Reset Signal	4-20 ma=0-100% Reset
4	Demand Limit Reset Signal	4-20 mA=0-100% Reset
5	Refrigerant Leak Sensor	4-20 mA=0-100PPM
6	Evap Water Flow (Gpm)	4-20 mA=0 - HiPressSpt
7	Cond Water Flow (Gpm)	4-20 mA =0 - HiPressSpt
8	Liquid Line Refrigerant Temp	Standard Temp -40 ^o -263 ^o F
9	Entering Condenser Water Temp	Standard Temp -40 ^o -263 ^o F
10	Leaving Condenser Water Temp	Standard Temp -40 ^o -263 ^o F
11	Motor Current	0-5V=0-125%RLA
12	Compressor Discharge Temp	Standard Temp -40 ^o -263 ^o F
13	Oil Feed Temp	Standard Temp -40 ^o -263 ^o F
14	Oil Sump Temp	Standard Temp -40 ^o -263 ^o F
15	Oil Vent Pressure	Standard Pressure 0-480psig
16	Evaporator Refrigerant Pressure	Standard Press 0-165psig
17	Condenser Refrigerant Pressure	Standard Press 0-480psig
18	Oil Feed Gauge Pressure	Standard Press 0-480psig
19	Transducer Power Voltage Ratio	Used for calibration
20	Outdoor Air Temp	Standard Temp -40 ^o -263 ^o F
21	Ent Heat Recovery Temp	Standard Temp -40 ^o -263 ^o F
22	Lvg Heat Recovery Temp	Standard Temp -40 ^o -263 ^o F
23	(Spare)	

Digital Inputs

Digital inputs indicate the status of external two-position devices such as a flow switch or remote time clock. The ADI board senses the presence or absence of 24VAC and provides a corresponding indication to the microprocessor control board.

No.	Description	Lo Voltage	Hi Voltage
0	Front Panel "Stop/Auto" Switch	Stop	Auto
1	Compressor High Pressure Switch	Alarm	Normal
2	Motor High Temperature (Guardistor)	Alarm	Normal
3	Vanes Closed	Closed	Open
4	Starter Transition	----	Delta
5	Starter Fault	Alarm	Normal
6	Evaporator Water Flow Switch	No Flow	Flow
7	Condenser Water Flow Switch	No Flow	Flow
8	Remote Start / Stop	Stop	Enabled
9-23	Open		

Controller Output Signals

Digital Outputs

Solid state digital relays are used to switch most of the external devices controlled by the MicroTech panel. These devices may be pumps or solenoids that are either on or off.

No.	Description	Off	On
0	Alarm LED and Contact	(Programmable)	(Programmable)
1	Unload Solenoid and Front Panel LED	----	Unload
2	Load Solenoid and Front Panel LED	----	Load
3	Motor Control Relay	Off	On
4	Motor Control Relay Latch	Unlatched	Latched
5	Oil Pump	Off	On
6	Oil Sump Heater	Off	On
7	Oil Cooler Close	Off	On
8	Oil Cooler Open	Off	On
9	* Hot Gas Bypass Solenoid	Closed	Open
10	* Liquid Injection	Off	On
11	Cooling Tower #1	Off	On
12	Cooling Tower #2	Off	On
13	Cooling Tower #3	Off	On
14	Cooling Tower #4	Off	On
15	Evaporator Water Pump #1	Off	On
16	Evaporator Water Pump #2	Off	On
17	Condenser Water Pump #1	Off	On
18	Condenser Water Pump #2	Off	On
19	Spare		
20	Spare		
21	Spare		
22	Spare		
23	Spare		

Analog Outputs (Optional)

The analog outputs available at the AOX board provide a variable voltage used to control field mounted devices. The range of the output signal is jumper selectable. 0 - 10 VDC (default); 0 - 5 VDC; 4- 20 mA.

No.	Description	Conversion
0	Cooling Tower Bypass Valve	0-10VDC : 0-100% Open
1	Proportional Motor Current Output	0-10VDC : 0-100% RLA
2	Future Use	
3	Future Use	

Sensor Wiring

All standard temperature sensors and pressure transducers are factory installed and wired. Optional sensors are supplied with an attached shielded cable that must be terminated at ADI board connector AH6 in accordance with the control schematic mounted inside the control panel door.

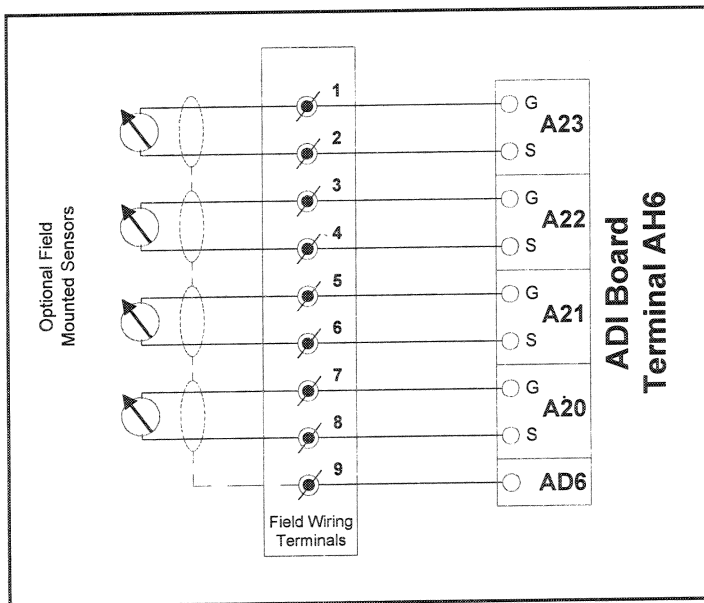

Installation

Sensor Mounting Locations

Sensor No.	Description
S00	Evaporator Leaving Water Temperature
S01	Evaporator Entering Water Temperature
S02	Compressor Suction Temperature
S03	External Chilled Water Reset (By Others)
S04	External Motor Current Reset (By Others)
S05	Refrigerant Leak Monitor Signal (By Others)
S06	Evaporator Water Flow Transmitter Signal (By Others)
S07	Condenser Water Flow Transmitter Signal (By Others)
S08	Condenser Liquid Line Temperature
S09	Condenser Entering Water Temperature
S10	Condenser Leaving Water Temperature
S11	Percent Unit Amps
S12	Compressor Discharge Temperature
S13	Oil Feed Temperature
S14	Oil Sump Temperature
S15	Oil Vent Pressure
S16	Evaporator Refrigerant Pressure
S17	Condenser Refrigerant Pressure
S18	Oil Feed Gauge Pressure
S19	Transducer Power Voltage Ratio
S20	Outdoor Air Temperature
S21	Heat Recovery Entering Water Temperature
S22	Heat Recovery Leaving Water Temperature
S23	Spare

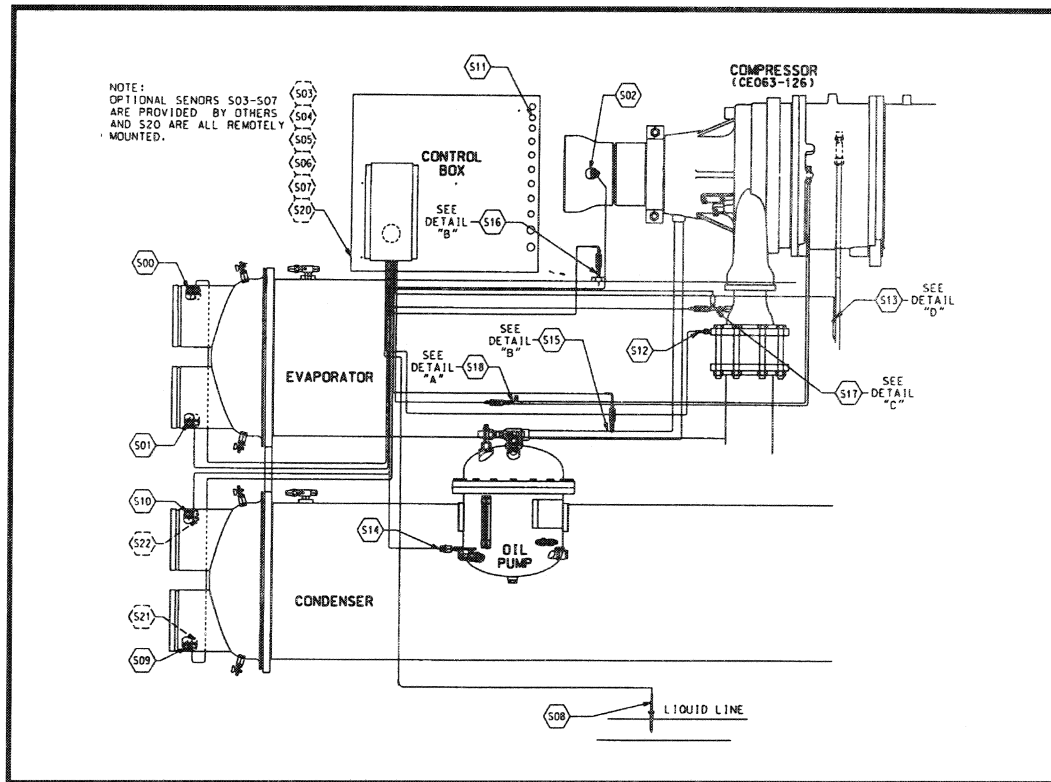

Starter Interface Wiring

McQuay centrifugal chillers are primarily designed for use with Star-Delta and auto-transformer starters requiring a transition between starting stages. Termination points are provided in the control panel for all control and status signals associated with conventional starters.

The MicroTech control panel can be interfaced to starters utilizing conventional thermal or magnetic overloads as well as solid state overloads such as the McQuay IQ-1000. For solid state protective devices, the normally closed overload contacts are wired in series with the MCR coils and an additional set of trip contacts are wired between terminals 6 and 22 of the MicroTech panel.

For conventional overloads, the normally closed overload contacts are wired in series with the MCR coils however, since there is no additional set of trip contacts, a jumper must be installed between terminals 6 and 22 of the MicroTech panel.

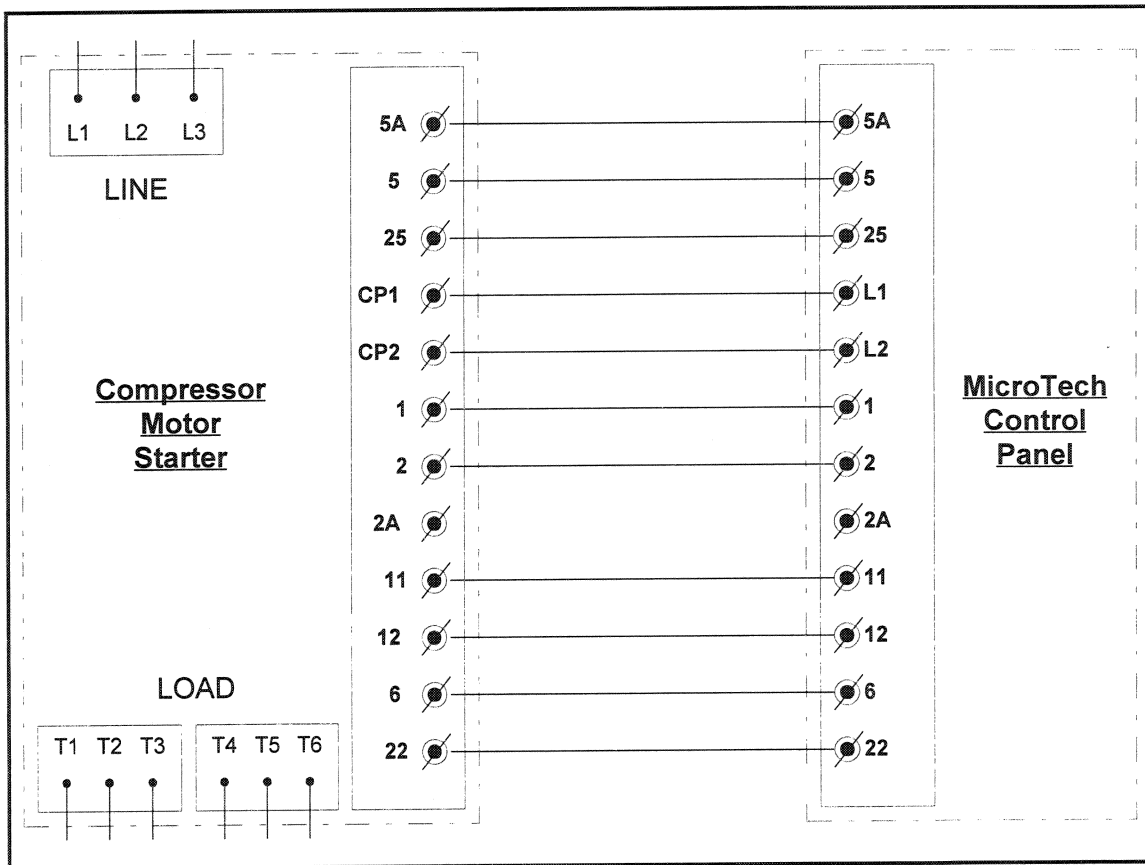

Pump Control Wiring

The MicroTech panel will control two evaporator and two condenser pumps in a primary / secondary configuration. The controller provides a 120VAC run signal at terminals 36 and 37 to control the primary and secondary evaporator pumps respectively. This signal is suitable for operating a standard control relay with a coil current rating of 2.5 amps or less. The neutral connection point for the control relay is terminal 44 or 45. Connections for the mandatory evaporator flow switch and pump contactor interlock are made across terminals 10, 62 and 63.

Sequencing of these outputs may be automatic or manual based on the pump control setpoints programmed in the controller.

The primary and secondary condenser pump control signals are available on terminals 35 and 34 respectively. These signals are suitable for operating a standard control relay with a coil current rating of 2.5 amps or less. The neutral connection point for the control relay is terminal 44 or 45. Connections for the mandatory condenser flow switch and pump interlock are made across terminals 10, 60 and 61. Sequencing of these outputs may be automatic or manual based on the pump control setpoints programmed in the controller.

Output Designation	Terminal #
Evaporator Pump #1	36
Evaporator Pump #2	37
Condenser Pump #1	35
Condenser Pump #2	34

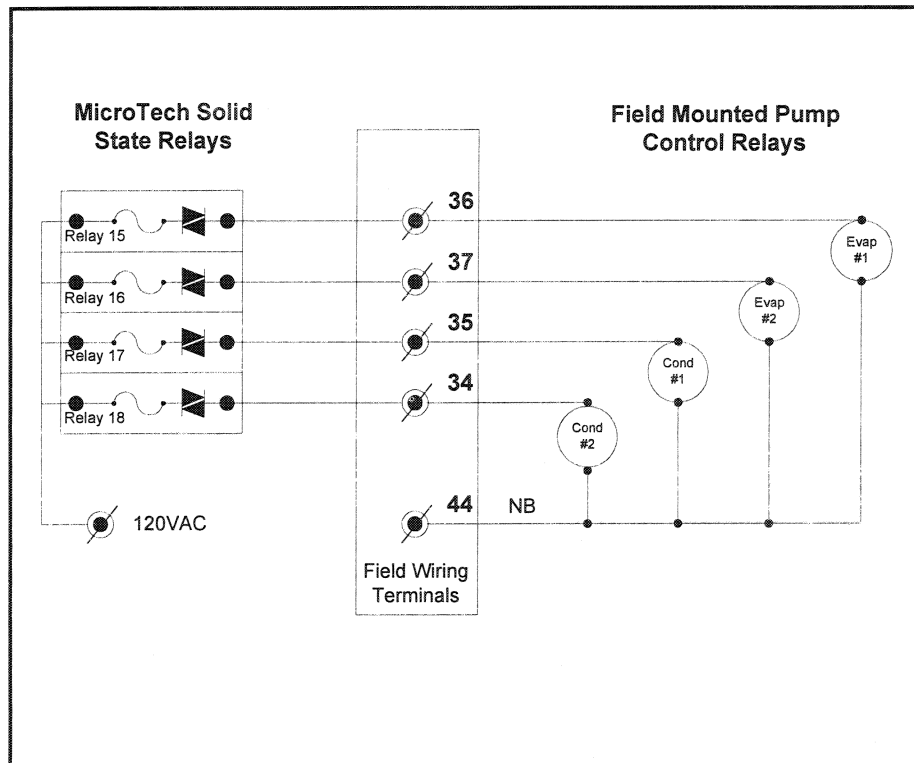

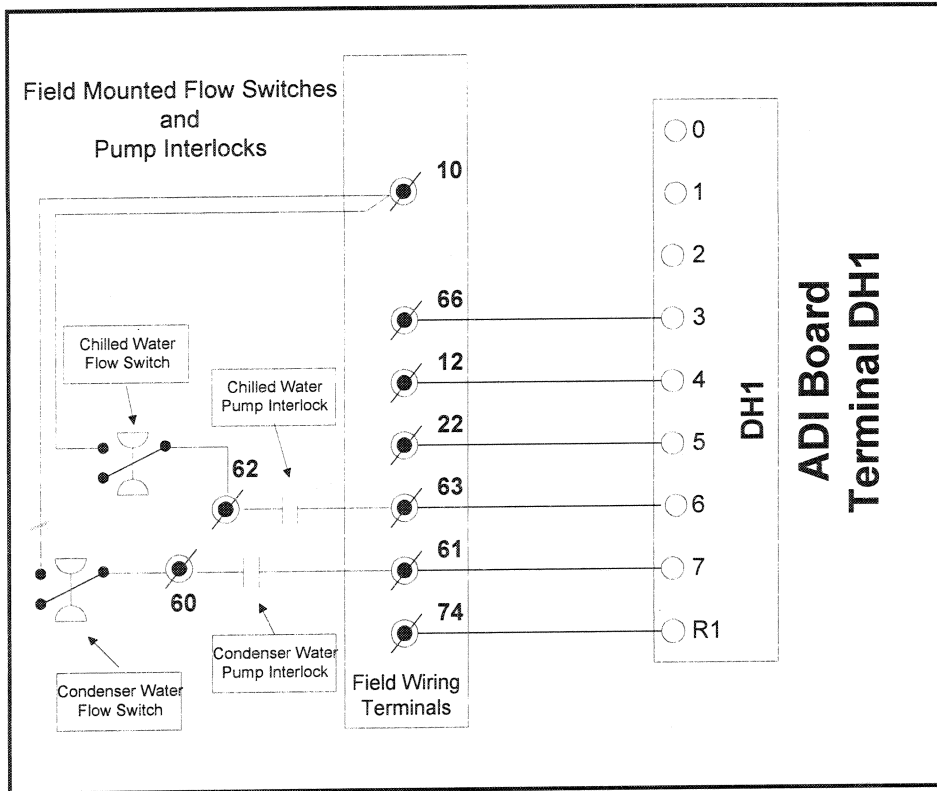

Tower Control Wiring

Four stages of cooling tower fan control are available in the MicroTech panel which are sequenced to maintain the entering condenser water temperature setpoint. Programmable setpoints determine the maximum number of fan stages available and the conditions under which they will be activated.

The tower fan signals are suitable for operating a standard control relay with a coil current rating of 2.5 amps or less. Terminal 44 or 45 may be used as the neutral connection point for the control relays.

Output Designation	Terminal #
Cooling Tower #1	39
Cooling Tower #2	38
Cooling Tower #3	40
Cooling Tower #4	41

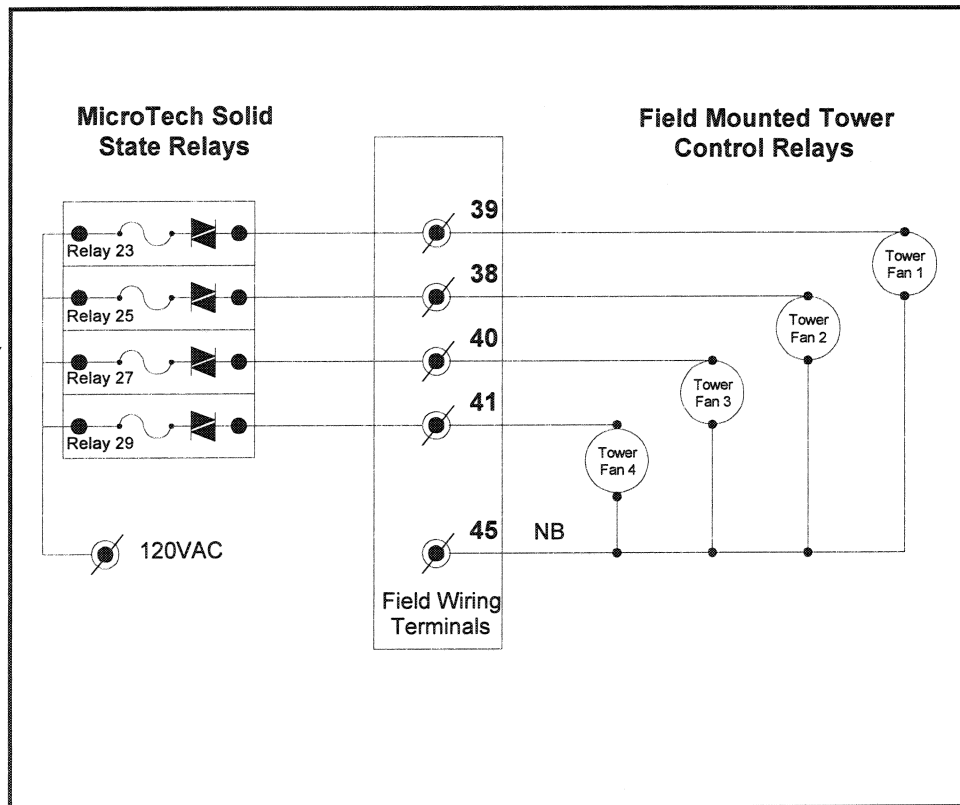

Tower Bypass Valve

An analog control signal is provided on the AOX board to modulate a 3-way cooling tower bypass valve. The control signal is based on the entering condenser water temperature and is in the range of 0 to 10 VDC, suitable for driving most Modutrol style actuators that require a 2-10 volt control. For pneumatic valves, a suitable E-P device may be used to interface the electric control signal to the pneumatic valve actuator.

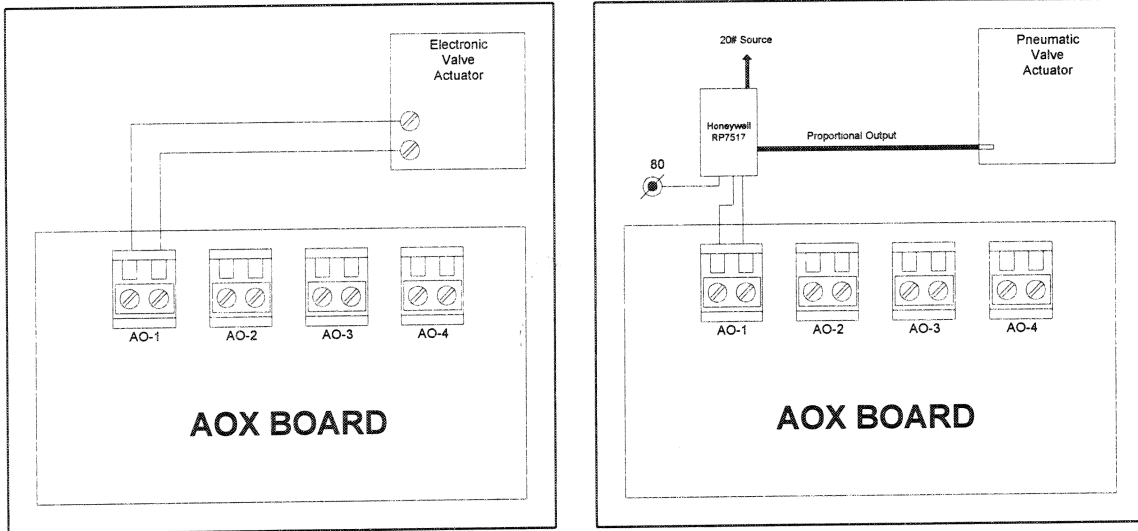

BMS Interface Wiring

Remote Start / Stop

Access for remote start / stop control of the chiller is provided at terminals 9 and 64. A dry contact closure across this 24V circuit will enable chiller operation. When the contact is open, the chiller start sequence will be inhibited or the chiller will stop if it is already running. **A jumper must be installed across terminals 9 and 64 if the remote start / stop feature is not used.**

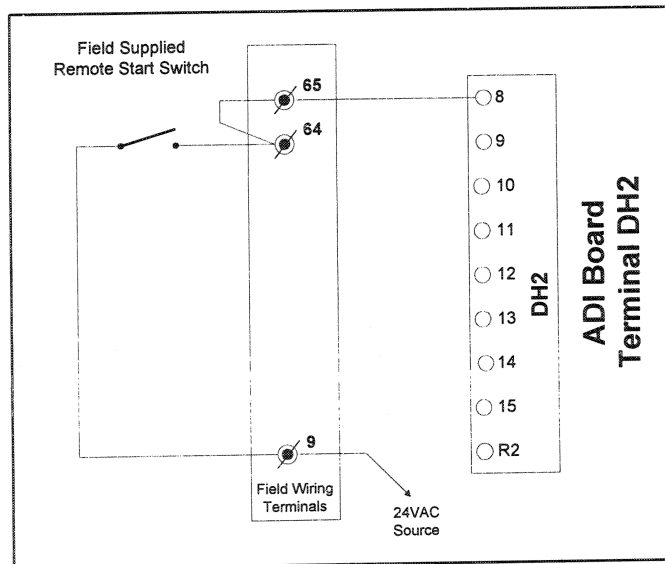

Chiller Capacity

If the optional AOX board is installed in the control panel, a signal proportional to the compressor's motor amperage is available at output AO-2. The signal is in the range of 0 to 10 VDC with 10 volts equal to 100% RLA. A jumper may be set on the AOX board to provide a proportional 4-20mA output if desired.

Remote Chilled Water Reset

When the chilled water setpoint source is set to "local" and the reset type is set to "remote", the leaving water temperature can be reset based on a customer supplied, external 4-20mA signal. The reset input connection at terminals AH1,1&2 is terminated with a 249 ohm resistor therefore the input signal must be in the range of 1-5 VDC. (1VDC = 4mA / 5VDC = 20mA)

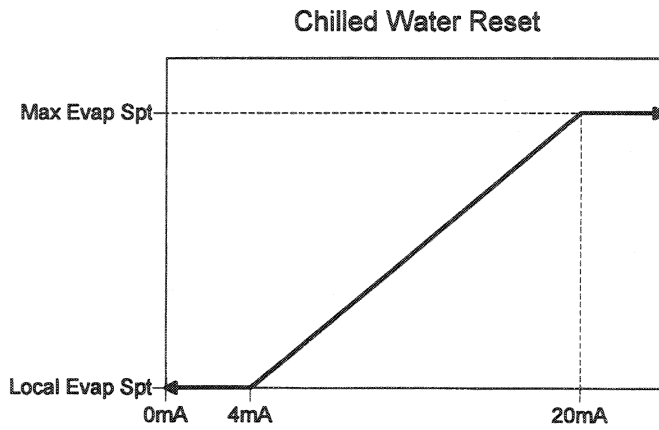

Remote Current Limit

The compressor can be demand limited based on a remote 4-20mA signal according to the following graph. The default differential setpoint is 40%. If the amp draw rises to the Max Amp setpoint, the chiller will inhibit loading. If the amp draw rises to 5% or more above the Max Amp setpoint, the chiller will begin unloading.

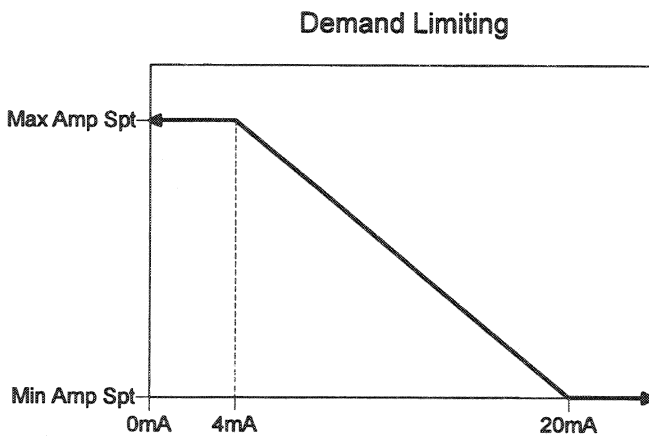

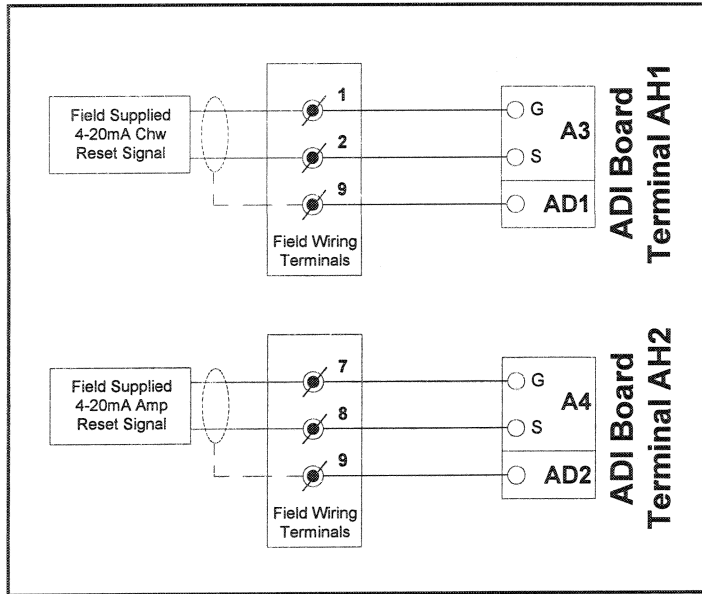

Audible Alarm Wiring

A customer furnished 24 volt alarm relay coil may be connected between terminals 50 and 68 of the control panel. The maximum rating for the alarm coil is 25VA. Operation of the alarm output is determined by operator programmable setpoints.

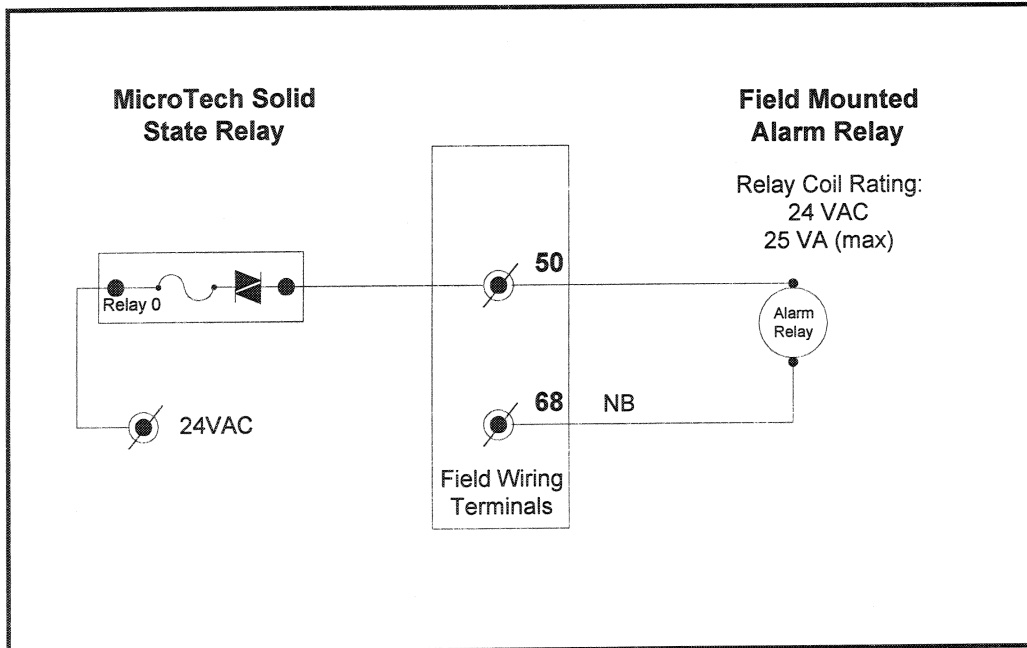

Network Wiring

For network communications between multiple MicroTech controllers, a twisted pair, shielded cable must be connected between all control panels in the network. Field wiring terminals 84, 85 and 86 are reserved for communications cable termination.

The network communications cable must meet the following minimum requirements:

Twisted, shielded pair with drain wire, 300 V, 60°C, 20 AWG, polyethylene insulated with a PVC outer jacket.
Some local codes or applications may require the use of plenum rated cable.

MicroTech network wiring must be installed in it's own conduit away from any high voltage wires with a maximum total cable length of 5000 feet.

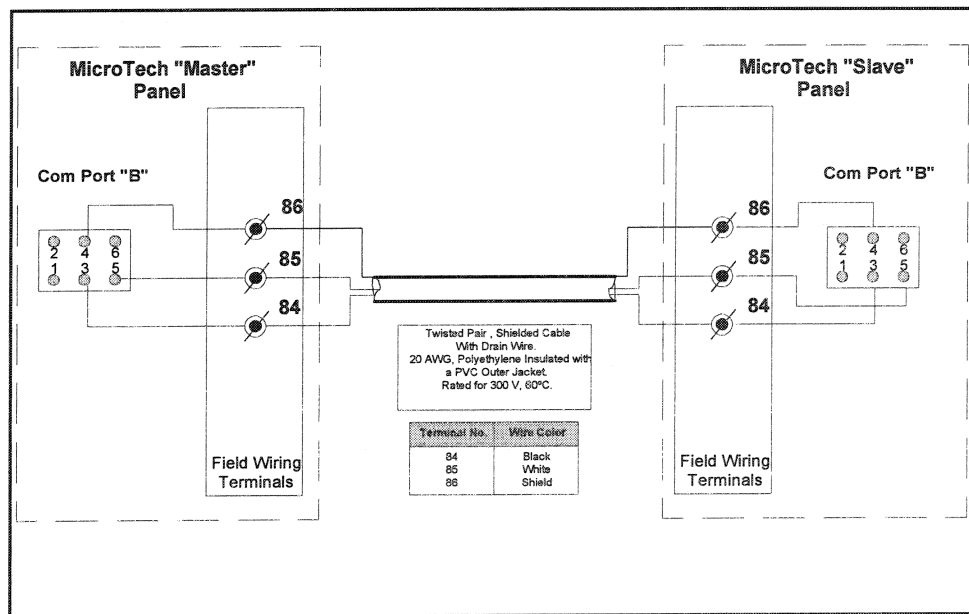

Modem Kit

An optional telephone modem may be installed to provide dial up capability into the MicroTech control panel. Modem installation requires the 072140601 modem kit that may be factory installed as part of the original chiller order or field installed as a separate order through McQuayService. Installation instructions are provided in a separate IM that is shipped with the kit.

Keypad / Display Operation

General Description

The MicroTech keypad consists of eighteen pressure sensitive membrane switches used to step through, access, and manipulate the information in the MicroTech controller. The selected information is presented on a four line by forty character backlit LCD display.

The information stored in the MicroTech controller can be accessed through the keypad by following the tree-like structure of menus and menu items. The keypad keys are divided into four groups with four or more keys in each to facilitate navigation through the available menus and items.

Category Group

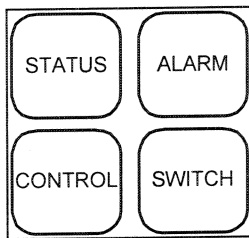

The keys in this group provide quick access to strategic menus throughout the menu tree-structure. This reduces the need to step through all the menus, one by one, in order to reach the desired information.

Status Key

Menus and menu items in this category provide information on the MicroTech operating conditions and the chiller operating conditions. The entries under each menu item in this category provide information only and are not changeable through the MicroTech keypad.

Pressing the "STATUS" key at any time shifts the display to Menu #1 (Unit Status) which is the first menu of the STATUS category.

Control Key

Menus and menu items in this category provide for the adjustment of all the unit control parameters. These include capacity control, pump control and cooling tower control parameters as well as time schedules and alarm limits. The entries under these menu items are changeable through the MicroTech keypad.

Pressing the "CONTROL" key at any time shifts the display to Menu #11 (Control Mode) which is the first menu of the CONTROL category.

Alarm Key

Menus and menu items in this category provide information regarding current and previous fault conditions along with the operating temperatures and pressures at the time the fault occurred.

Pressing the "ALARM" key at any time shifts the display to Menu #27 (Current Alarm) which is the first menu of the ALARM category.

Switch Key

Pressing the "SWITCH" key at any time toggles the display between the current menu (status/control) item and the related menu (control/status) item somewhere else in the tree-structure. For example, if this key is pressed while the current menu item is menu item 2B (Leaving Evaporator =), the display shifts to menu item 12B (Local Evaporator Setpoint =). This provides for easy review of actual versus setpoint values.

Menu - Item Group

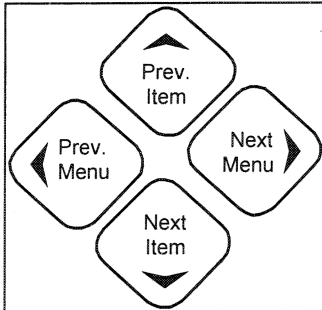

The keys in this group are for navigating through the various menus and items presented on the controller's display.

Previous Menu

Pressing "PREV.MENU" shifts the display to the previous menu. Note: When Menu #1 is currently in the display (the first menu in the menu tree-structure), pressing "PREV.MENU" causes an "end of menus" message to appear in the display. Pressing "PREV.MENU" again causes the display to wrap around to the last menu in the menu tree structure.

Next Menu

Pressing "NEXT MENU" shifts the display to the next menu. Note: When Menu #29 is currently in the display (the last menu in the menu tree-structure), pressing "NEXT MENU" causes an "end of menus" message to appear in the display. Pressing "NEXT MENU" again causes the display to wrap around to the first menu in the menu tree structure.

Previous Item

Pressing "PREV.ITEM" shifts the display to the previous group of items within a menu. Note: When the first item in a menu is currently in the display, pressing "PREV.ITEM" causes an "end of items" message to appear in the display. Pressing "PREV.ITEM" again causes the display to wrap around to the last group of items in the menu.

Next Item

Pressing "NEXT ITEM" shifts the display to the next group of items in a menu. Note: When the last item in a menu is currently in the display, pressing "NEXT ITEM" causes an "end of items" message to appear in the display. Pressing "NEXT ITEM" again causes the display to wrap around to the first group of items in the menu.

Action Group

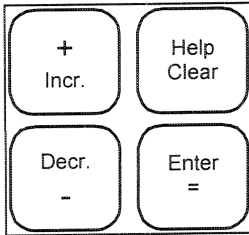

The keys in this group are for making changes to unit control parameters or for clearing fault conditions.

Note: Before a change to a parameter can be made or before a fault can be cleared, the display prompts the user with an "Enter Password" message. At this point, the password must be entered before the user can continue with the action.

Increment (+)

When changing the value of a menu item entry, pressing "INCR. +" shifts the selected menu item to the next higher value or next available selection.

Decrement (-)

When changing the value of a menu item entry, pressing "DECR. -" shifts the selected menu item to the next lower value or previous available selection.

Enter (=)

Once a change has been made to a desired value, pressing "ENTER =" locks in the new value.

Help / Clear

Pressing "ALARMS" followed by "CLEAR" clears the current fault. Also, when a change is made to a menu item, pressing "CLEAR" returns the display to the original value as long as "ENTER" has not yet been pressed.

Note: The cause of a fault should always be determined and corrected before resetting the fault through the keypad.

Keypad Password

When changing any menu item entry, the user is prompted to enter a valid password. The change will not be allowed until the correct password is entered. The password for centrifugal units is always four successive presses of the "Enter" key.

Once this has been done, the user can make changes to menu item entries. After entering the correct password, the controller will allow a 5 minute time period during which the operator may make any necessary setpoint adjustments. Any keypad activity will reset the timer for the full 5 minutes so the password only needs to be entered once per session. After 5 minutes of inactivity, the password access time will expire providing protection against unauthorized users.

Quick Access Group

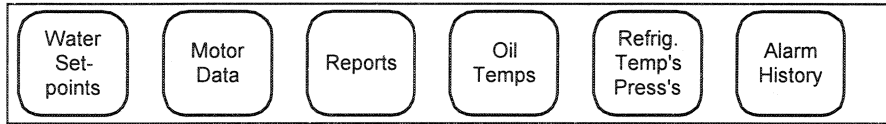

The Quick Access keys provide a fast shortcut directly into the most frequently used MicroTech menus. For example, pressing the Water Setpoints key moves you directly to menu #12 without having to step through intermediate menus via the Previous and Next keys.

Display Format

The information stored in the MicroTech controller tree structure can be viewed directly on the control panel's 4 line by 40 character display. The currently selected MENU is shown on the top line along with the current date and time. Up to six menu items may be shown on the lower three lines of the display.

Either U.S. Customary or SI engineering units may be displayed by installing the appropriate controller software.

U.S. Customary Units:

Temperature = ° F (Fahrenheit)
Pressure = Psi (Pound per sq. inch)
 Psig
 Psid

SI Units:

Temperature = ° C (Celsius)
Pressure = kPa (Kilo Pascals)
 kPag
 kPda

Pre-Start Checkout

Hexadecimal Switches

For proper chiller operation, each MicroTech controller must have a unique network address. The controller's hex switch settings define it's location in a network as well as it's unit type. For a stand-alone chiller, the Hi and Lo switches should be set to 0 and 1 respectively. This is also the correct setting for the "master" chiller in a Lead/Lag configuration. The Hi and Lo hex switch settings for the "slave" chiller in a Lead/Lag configuration are 0 and 2 respectively.

After changing a hex switch setting, the controller's power must be cycled by opening, and then closing, the panel circuit breaker.

Note: The chiller should be in an "Off" mode before resetting the hex switch positions.

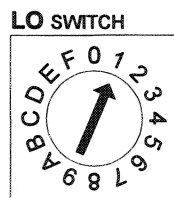
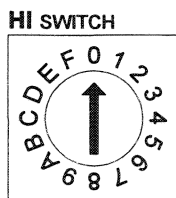

Powering the Control Panel

There are three status LEDs located on the modem 280 controller which will indicate the microprocessor's operating condition. When power is first applied to the control panel, the red **reset** LED will illuminate for approximately 3 seconds. During this time, the microprocessor is checking the control software and performing internal hardware tests. When these tests are complete the **reset** LED will turn off and the green **running** LED will illuminate indicating the controller's circuitry and software are operating correctly.

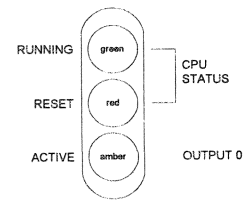

The amber **output 0 active** LED is associated with the external alarm output. This LED may or may not be illuminated at this time based on the setpoints under menu 23.

If the **reset** LED stays on or the **running** LED fails to illuminate, disconnect the controller power by opening circuit breaker CB-1 and re-check the field wiring. Observe the controller's LEDs while re-connecting power by closing CB-1. If the green **running** LED still does not turn on, a hardware failure exists or the control software is corrupted. Downloading new control software or replacing the 280 controller should correct the problem.

ADI board LEDs 1, 2, 4, 5 and 8 should be illuminated at this time and the unit status should be "Off Manual Setpoint".

With the controller powered up and the green **running** LED illuminated, the backlite panel on the display module will be illuminated and the unit status menu will be visible. If the display text looks faded or appears as "blocks" the contrast control needs to be adjusted. Watch the display and adjusting the contrast control with a small flat-blade screwdriver until the best setting is determined.

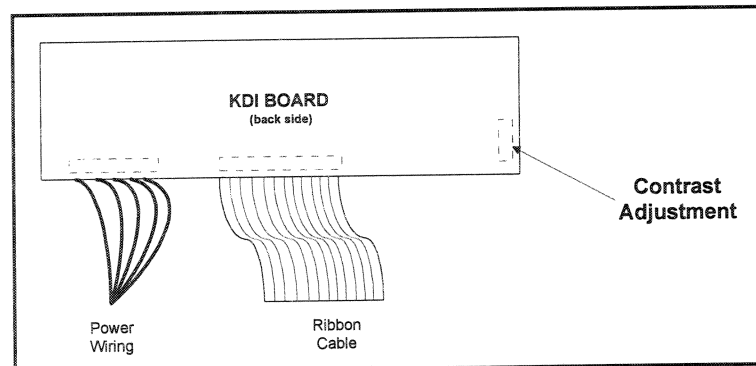

The MicroTech controller contains factory installed default setpoints which will be appropriate for most common installations. Step through all of the unit's setpoints by using the keypad / display and adjust them as required to meet the specific job requirements. Any faults appearing on the display should be cleared at this time by pressing the **clear** key.

Software Identification

The control software name will identify the unit type, refrigerant type and displayed engineering units. In addition, the software version and revision number are listed.

The software program codes (IDENT) will be as follows:

Section	Options
PEH	PEH - Standard Unit TEH - Templifier/Chiller PLH - Condenserless Chiller SEH - Evaporatorless Unit
4	2 - R12 Refrigerant 4 - R134a Refrigerant
E	E - U.S. Customary M - SI
01	01 - FF: Version number
0	0, A - Z: Revision number

Example:

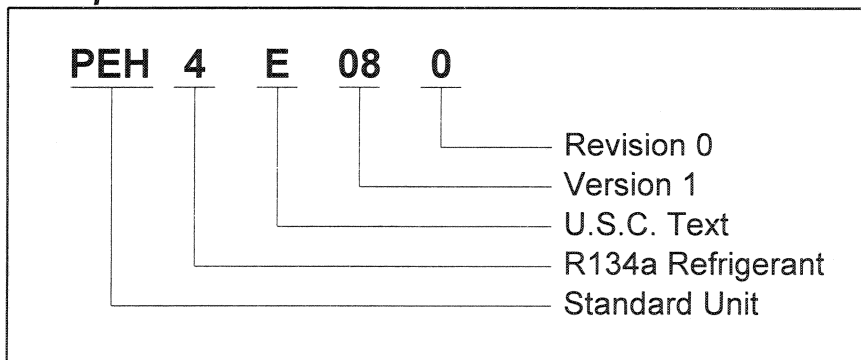

Unit Startup

Dry Running the Control Panel

On initial startup of a new chiller, it is recommended that the installing technician “dry run” the starter and control panel to check the operation of all operating and protective controls. This is accomplished by disconnecting the motor power wires at the starter. The MicroTech panel checks for the presence of current flow to the motor during the start sequence. The absence of motor amperage will initiate a shutdown sequence before the controls can be checked. To simulate the presence of motor current, disconnect the positive signal wire at terminal AH3-1 on the ADI board. This action will impress a false amperage reading on the input to the ADI board and allow the start sequence to commence.

If an IQ1000 motor protection device is present in the starter, the positive signal wire at terminal AH3-1 must be disconnected and the FLA setpoint in the IQ1000 must be set to the lowest possible value. Refer to IM561, *IQ1000 Motor Protection System*, for additional information.

Once the dry run test is completed, reconnect the positive signal wire at ADI board terminal AH3-1, reconnect the motor power wires to the correctly phased terminals at the starter and restore any IQ1000 setpoints that were changed.

Starting The Compressor

Prior to starting the compressor, all procedural steps normally associated with starting a newly installed machine must be completed. It is vital that the technician confirm proper rotational direction of the compressor motor by means of a phase sequence test device or by momentarily “bumping” the motor.

Note:

- ***The main disconnect must be opened whenever any wiring changes are made.***
- ***The compressor motor may be “bumped” only after all other start-up steps are completed.***

A momentary contact, hand held push-button switch may be wired between terminal #25 in the MicroTech control panel and terminal #25 in the starter in place of the normal wiring. The push-button should be suitable for 115VAC operation and rated for 50VA with leads of sufficient length that the technician can observe motor rotation at the motor end cover sight glass while operating the switch. The switch should open when released so that the technician can interrupt motor power instantly as the motor begins to turn.

With the push-button switch held in the closed position, a chiller start sequence can be initiated. The control panel will start the water pumps and oil pump as part of the normal startup sequence and then activate the MCR output. The direction of motor rotation can be determined within a few electrical cycles after the MCR relay contacts close. The technician should immediately release the “bump” switch, opening the MCR relay circuit which will stop the compressor motor.

Once correct motor rotation has been confirmed, the “bump” switch may be disconnected and the normal wiring may be restored.

State diagrams

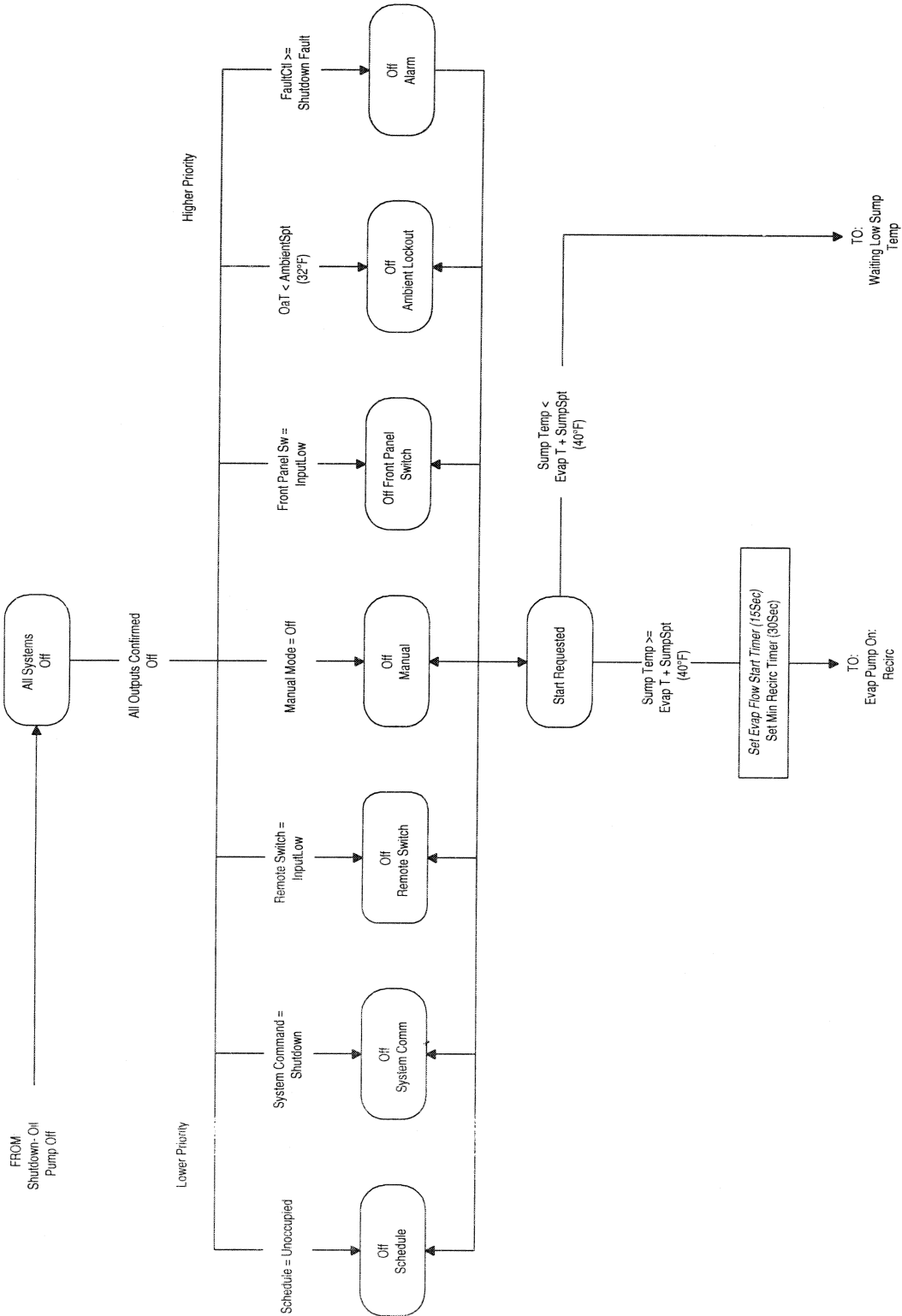

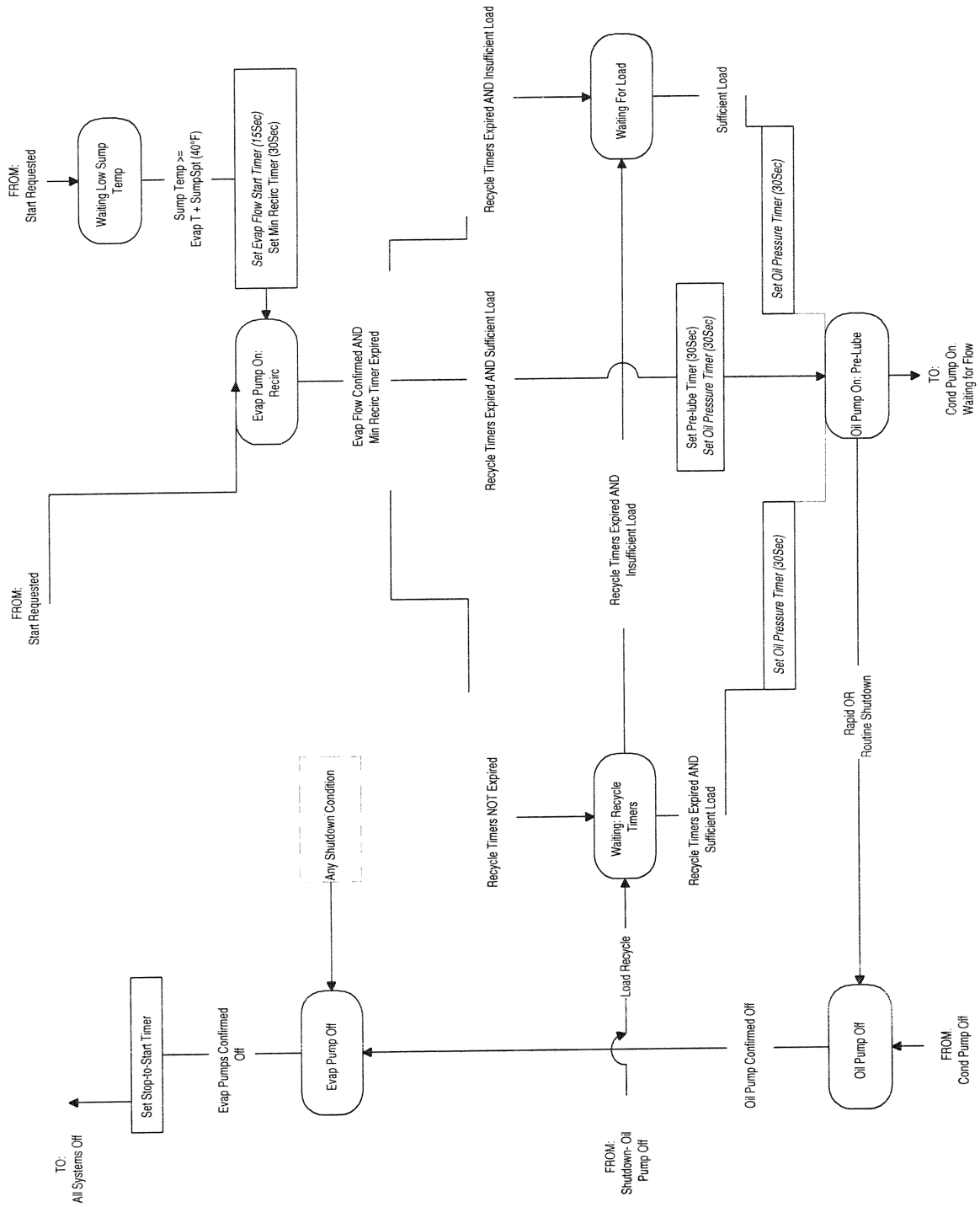

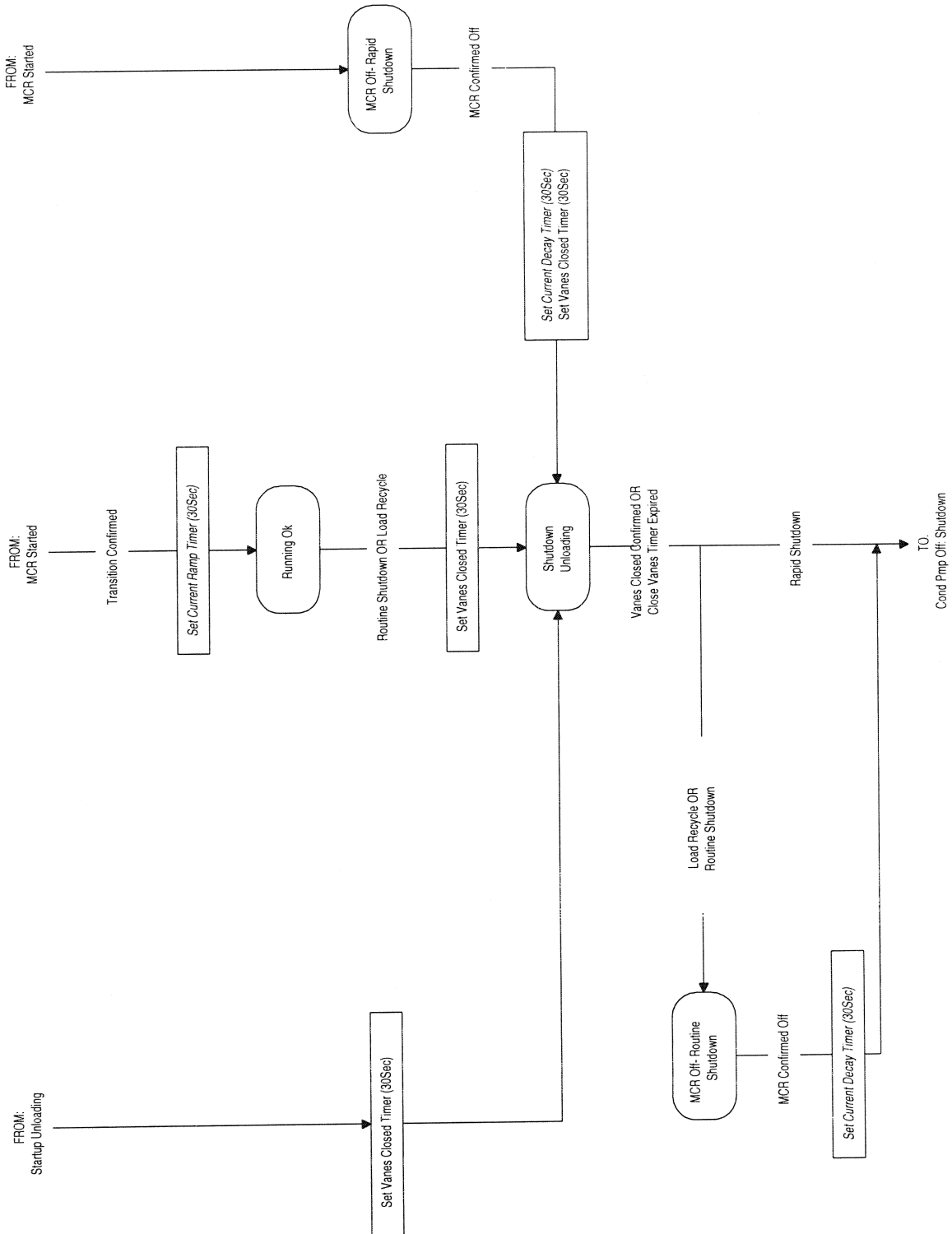

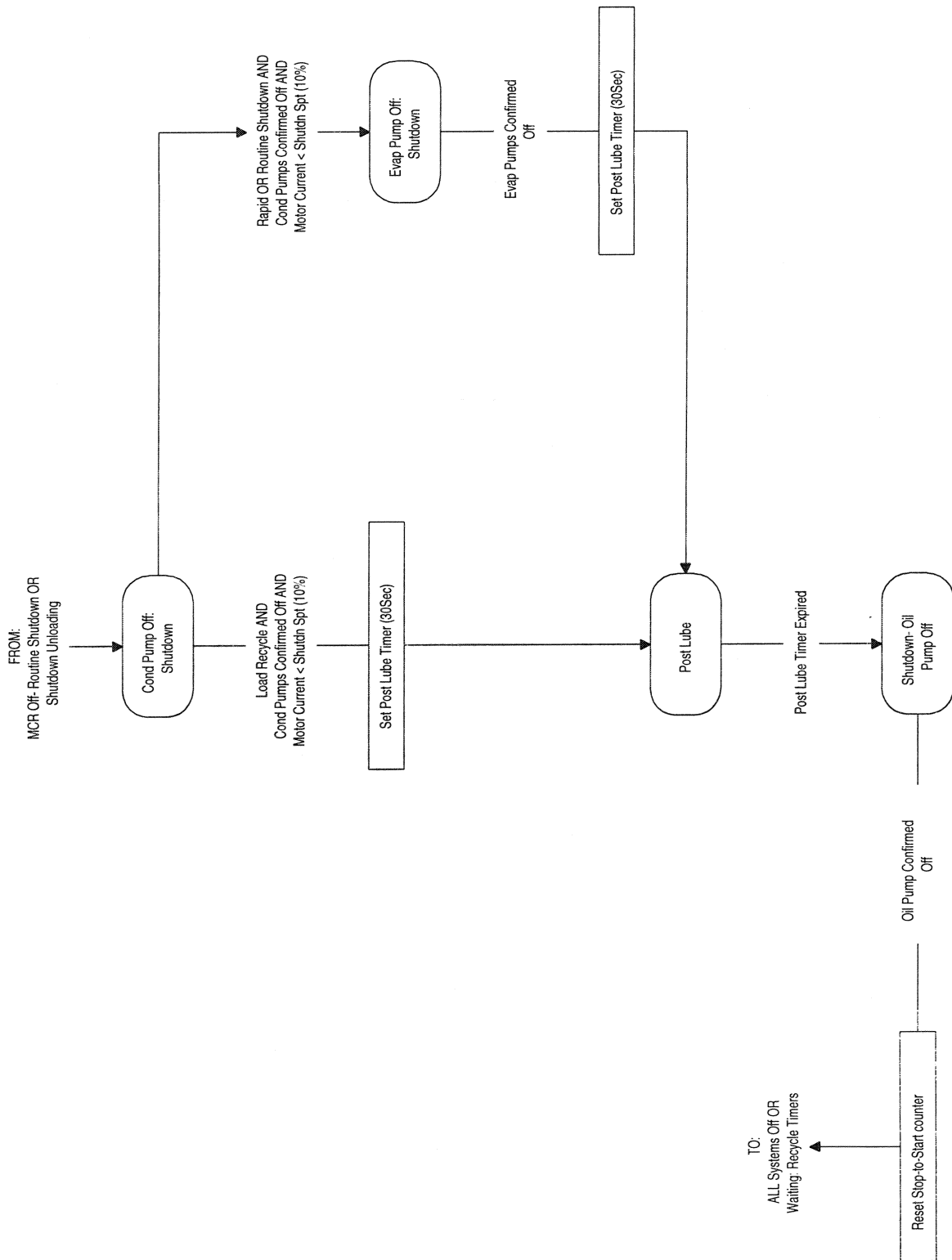

Safety Systems

Any condition that requires corrective action by the controller that overrides normal chiller operation or any condition that initiates an emergency chiller shutdown can be considered to be an alarm. Alarms are arranged in increasing priority with higher priority alarms replacing any lower priority alarms that may exist. Once the abnormal condition is corrected, the alarm may be cleared by pressing the *Clear* key.

Alarms fall into three distinct categories: *Warnings*, *Problems* and *Faults*.

Warnings

A warning is annunciated whenever an abnormal condition exists which does not affect chiller operation.

Warning	Condition	Display
Liquid Line Refrigerant Temperature Sensor Fail Warning	Sensor is shorted or open	Liq Line T Sen Warn
Entering Evaporator Water Temperature Sensor Fail Warning	Sensor is shorted or open	Ent Evap T Sen Warn
Leaving Condenser Water Temperature Sensor Fail Warning	Sensor is shorted or open	Lvg Cond T Sen Warn
Low Discharge Superheat	Discharge Superheat temperature is lower than acceptable range for more than 3 Minutes (Adjustable)	Low Disch Superheat
High Discharge Superheat	Discharge Superheat temperature is higher than acceptable range for more than 3 Minutes (Adjustable)	Hi Disch Superheat

Problems

A problem condition exists whenever the MicroTech controller must override normal chiller operation in order to keep the unit on line.

Problem	Condition	Display	Action	Clear
Entering Evaporator Water Temperature Sensor Fail Problem	Sensor is shorted or open AND Leaving Water reset is based on Entering Water Temperature	Ent Evap T Sen Prob	Leaving Water reset will change to No Reset	Manual. Reset will revert back to Entering Water on clearing
Outside Air Temperature Sensor Fail Problem	Sensor is shorted or open AND Leaving Water reset is based on Outside Air Temperature	Outside T Sen Prob	Leaving Water reset will change to No Reset	Manual. Reset will revert back to OAT on clearing
Low Evaporator Pressure-Inhibit Loading	Evaporator Pressure is less than low limit (38 PSIG)	Lo Evap Pres-NoLoad	Inhibit loading	Automatically when Evaporator Pressure rises above setpoint plus differential
Low Evaporator Pressure-Unload	Evaporator Pressure is less than low limit (31 PSIG)	Lo Evap Press-Unload	Unload to minimum position	Automatically when Evaporator Pressure rises above setpoint plus differential
High Discharge Temperature-Load	Discharge temperature > high limit (120° F) AND Suction Superheat < Low Limit (15° F)	High Discharge T-Load	Load compressor	Automatically when: Discharge Temperature < High Limit - Diff (3°F) OR Suction Superheat > Low Limit + Diff (3°F)
Condenser Freeze Protect	Condenser Refrigerant Temperature < Condenser Freeze Protect Setpoint (34°F)	Cond Pres Lo-Freeze	Start the Condenser pump	Condenser Refrigerant Temperature > Condenser Freeze Protect Setpoint + Differential (2°F)
Evaporator	Evaporator	Evap Pres Lo-	Start the	Evaporator

Freeze Protect	Refrigerant Temperature < Evaporator Freeze Protect Setpoint (34°F)	Freeze	Evaporator pump	Refrigerant Temperature > Evaporator Freeze Protect Setpoint + Differential (2°F)
Evaporator Pump 1 Fail	Unit Status > EvapPmpOn_Recirc AND UnitStatus < EvapPumpsOff AND Evaporator Water Flow switch digital input in No Flow position for more than 3 seconds(adjustable) AND Evaporator pump 2 is present AND Evaporator pump 2 has not yet failed.	Evap Pump #1 Fail	Unit will try to start evaporator pump 2	Manual
Evaporator Pump 2 Fail	Unit Status > EvapPmpOn_Recirc AND UnitStatus < EvapPumpsOff AND Evaporator Water Flow switch digital input in No Flow position for more than 3 seconds(adjustable) AND Evaporator pump 1 is present AND Evaporator pump 1 has not yet failed.	Evap Pump #2 Fail	Unit will try to start evaporator pump 1.	Manual
Condenser Pump 1 Fail	Unit Status > CondPmpOn_WaitingForFlow AND	Cond Pump #1 Fail	Unit will try to start condenser pump 2	Manual

	UnitStatus < CondPumpOff AND Condenser Water Flow switch digital input in No Flow position for more than 3 seconds(adjust able) AND Condenser pump 2 is present AND Condenser pump 2 has not yet failed.			
Condenser Pump 2 Fail	Unit Status > CondPmpOn_ WaitingForFlow AND UnitStatus < CondPumpsOff AND Condenser Water Flow switch digital input in No Flow position for more than 3 seconds(adjust able) AND Condenser pump 1 is present AND Condenser pump 1 has not yet failed.	Cond Pump #2 Fail	Unit will try to start condenser pump 1	Manual

Faults

The chiller will be shut down by the MicroTech control panel in response to any of the following fault conditions. These faults must be cleared manually to restart the unit.

Fault	Condition	Display
Low Evaporator Pressure	Evaporator Pressure is less than low limit (26 PSIG)	Lo Evap Pressure-SD
Low Oil Delta Pressure	Oil Pump output has been energized for more than 30 seconds and Oil Feed Pressure is less than the Evaporator Refrigerant Pressure by more than the alarm setpoint (30PSI)	Low Oil Delta Press
Low Oil Feed Temperature	Oil Feed temperature is less than Evaporator Refrigerant Temperature plus Low Oil Delta Spt (30°F) for greater than 1 minute (adjustable)	Low Oil Feed Temp
High Oil Feed Temperature	Oil Feed temperature is greater than high limit (140°F) for greater than 1 minute (adjustable)	High Oil Feed Temp
Low Motor Current	MCR has been energized for more than 30 seconds AND Motor Current is less than low limit (10%)	Low Motor Current
High Motor Current	MCR has been de-energized for more than 30 seconds AND Motor Current is greater than shutdown limit (10%)	High Motor Current
High Discharge Line Temperature	Discharge Temperature is > Setpoint (190°F)	Hi Disch Line Temp
High Condenser Pressure	Condenser Pressure is greater than high limit (140 PSI) OR High Cond Pressure digital input in Alarm position	Hi Condenser Press
Mechanical High Pressure Switch	High Pressure digital input in Alarm position	Mech Hi Pres Switch
High Motor Temperature	Motor High Temperature digital input in Alarm position	High Motor Temp
High Suction Superheat	Suction Superheat temperature > Setpoint (50°F)	Hi Suction Superht
No Starter Transition	MCR has been turned on	NoStarterTransition

	more than 15 seconds AND Starter Transition digital input is not in Delta position	
No Evaporator Water Flow Fault	Unit Status > EvapPmpOn_Recirc AND Unit Status < EvapPmpsOff_Shutdn AND Evaporator Water Flow switch digital input in No Flow position for more than 3 seconds (adjustable)	No Evap Water Flow
No Condenser Water Flow Fault	Unit Status > CondPmpOn_WaitingForFlow AND Unit Status < CondPmpsOff_Shutdn AND Condenser Water Flow switch digital input in No Flow position for more than 3 seconds (adjustable)	No Cond Water Flow
Starter Fault	MCR Output energized AND Starter Fault digital input in Alarm position	Starter Fault
No 5Vdc at sensor #19	Analog sensor #19 value is < 213 or > 252 counts	No 5Vdc at Sen #19
Leaving Evaporator Water Temperature Sensor Fail	Sensor is shorted or open	Lvg Evap T Sen Fail
Evaporator Pressure Sensor Fail	Sensor is shorted or open	Evap Press Sen Fail
Entering Condenser Water Temperature Sensor Fail	Sensor is shorted or open	Ent Cond T Sen Fail
Suction Temperature Sensor Fail Warning	Sensor is shorted or open	Suction T Sen Fail
Discharge Temperature Sensor Fail	Sensor is shorted or open	Discharg T Sen Fail
Condenser Pressure Sensor Fail	Sensor is shorted or open	Cond Press Sen Fail
Oil Feed Temperature Sensor Fail	Sensor is shorted or open	Oil Feed T Sen Fail
Oil Sump Temperature Sensor Fail	Sensor is shorted or open	Oil Sump T Sen Fail

Network Operation

Network Configuration

Two centrifugal MicroTech controllers may be networked together to provide automatic selection of lead and lag compressors as well as load balancing when both compressors are operating. In this configuration, one unit will be designated as the “master” and the other unit will be designated as the “slave”. The master unit will control all network functions and communications. In the event that communications between the two MicroTech panels is lost, both controllers will revert back to “local” control.

Lead/Lag Load Balance Functions

A customer supplied contact closure or the master unit’s time schedule will be used to determine the enable / disable status for both compressors. When chiller operation is enabled, the lead compressor will start and adjust it’s capacity to satisfy the cooling load. If the lead compressor runs at a capacity greater than the *Enable Lag* setpoint for a time greater than the *Lag Start Delay* setpoint, and the leaving evaporator water temperature is greater than the *Start Up Delta Temperature* setpoint, the lag compressor will be started. With both compressors operating, the master control panel will balance the cooling load between the two compressors to within 5%RLA. If the *Max Chillers* setpoint is set to 1, the lag compressor is considered to be a backup and will only be started if the lead compressor is off due to a fault. See OM125 (585515Y) for a detailed operational description.

Network Chilled Water Setpoint

When two MicroTech control panels are used in a master / slave configuration, the slave controller will modulate to maintain the chilled water temperature at the “network” setpoint which is transmitted over the network by the master controller.

Network Demand Limit

A remote 4-20mA demand limit signal should be wired to the master controller only. The master panel will transmit the reset signal over the network to the slave controller.

Loss of Communications

The master control panel will transmit a number of control parameters to the slave control panel that determine whether or not the slave compressor should be running and what it’s capacity should be. The slave controller will revert to “local” operation if network communications is lost. Care must be taken to ensure that all local setpoints and time schedules are appropriate for each particular installation.

Unit Schematics

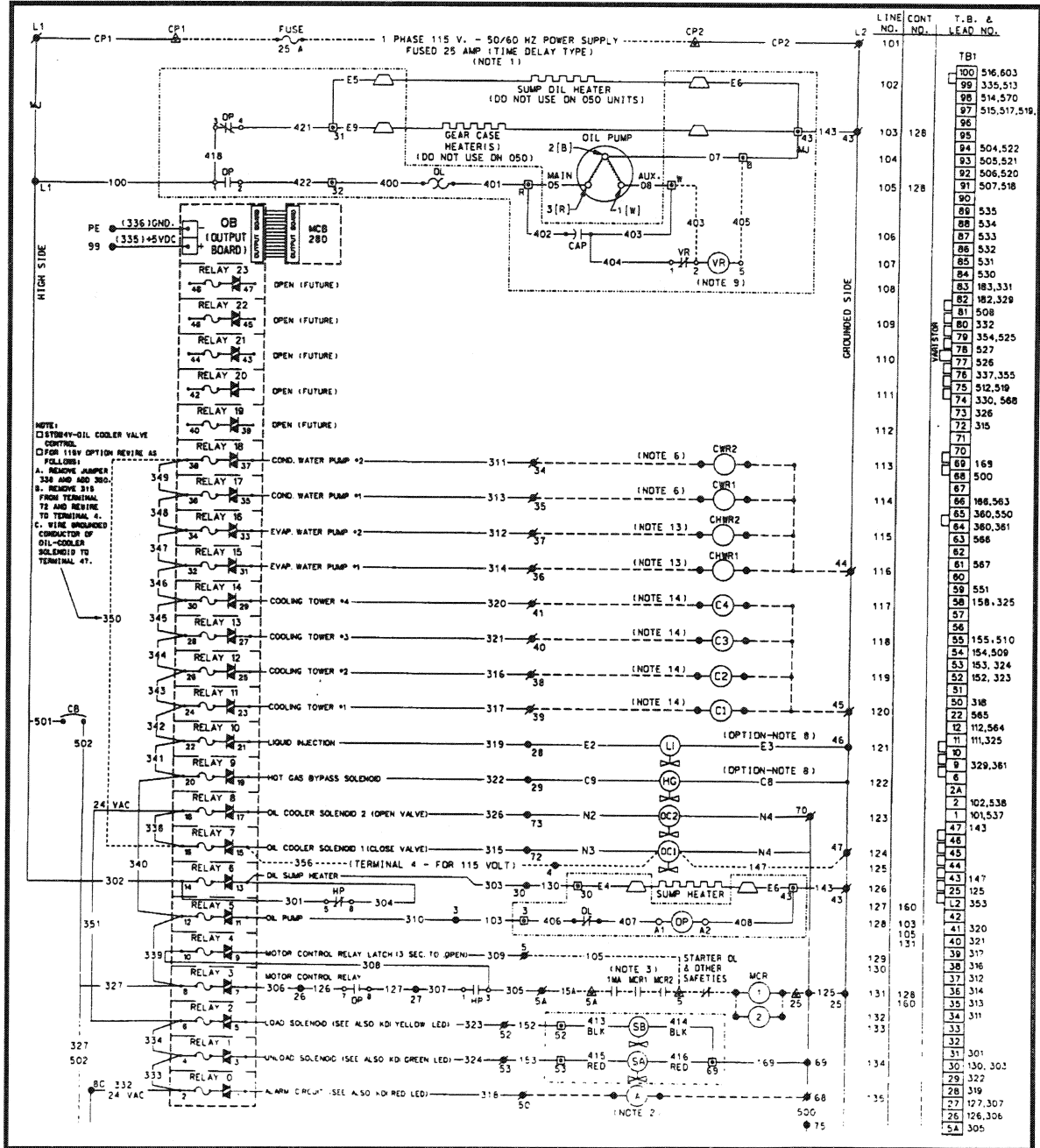



13600 Industrial Park Blvd., P.O. Box 1551, Minneapolis, MN 55440 USA (612) 553-5330

 Printed on recycled paper containing at least 10% post-consumer recycled material.