



SUBJECT: IQ-1000 II Default Settings and Calibration	NUMBER: C9632 DATE: 9-16-96 SUPERSEDES:
MODELS AFFECTED: All 19XR/XRT Chillers, 19XL & 23XL Chillers Shipped After 10-28-96 with Unit Mounted Starters	DATE: PAGE: 1 OF: 13
Installation, repair and service and equipment referenced in this Service Bulletin should be undertaken only by qualified persons. Carrier Corporation: (1) makes no representations or warranties, expressed or implied, concerning the accuracy, completeness or right to use the information contained herein. (2) Disclaims all liability for injuries, damages, infringements and other losses which may arise on account of, or which may result from, the use or application of any information, method or apparatus disclosed herein.	

PURPOSE:

To provide information about the calibration and default settings for the IQ-1000 II Motor Protection System.

BACKGROUND:

Cutler-Hammer unit-mounted starters on 19XR/XRT machines are equipped with the IQ-1000 II Motor Protection System. Some field purchased starters may also be equipped with the IQ-1000 II, which provides all current-based safeties. Specifically, it provides phase unbalance protection, motor overload protection, and phase-to-ground fault protection. It also provides a 4-20 mA signal which is used to input motor amps to the PIC.

DEFAULT SETTINGS AND PROGRAMMING FOR THE IQ-1000 II:

DEFAULTS:

Default settings are programmed into the IQ-1000 II at the factory and the complete Set Point Record Sheet is included in this bulletin. The settings will not vary between machines, with the exception of RATED LOAD AMPS (RLA), LINE FREQUENCY, and LOCKED ROTOR CURRENT IN % FLA. All the default settings are printed on the door of the starter and programming is described in the IQ-1000 II Manual in Section 8, "PROGRAMMING THE IQ-1000 II AND SET POINT DESCRIPTION".

GENERAL:

This bulletin includes a summary of the IQ1000 II operating instructions and a description of its interface with the chiller controls. More complete information can be found in the IQ-1000 II Motor Protection System User's Manual.

**Carrier**

A United Technologies Company

REPLACEMENT COMPONENTS DIVISION

SERVICE BULLETIN**SUBJECT:** IQ-1000 II Default Settings and Calibration**NUMBER:** C9632**DATE:** 9-16-96**SUPERSEDES:****MODELS AFFECTED:** All 19XR/XRT Chillers, 19XL & 23XL Chillers Shipped After 10-28-96 with Unit Mounted Starters**DATE:****PAGE:** 2 **OF:** 13

The connections to the PIC circuitry are on the back of the IQ-1000 II and can be accessed by opening the starter enclosure door. Terminals 12 and 13 are used as the main trip terminals and terminals 15 and 16 are used as ground fault current trip contacts. Both sets of terminals are connected in series in the PIC 1CR circuit.

Terminals 15 and 16 will be jumpered if the ground fault protection option of the IQ-1000 II is not used.

The alarm contacts are not used with the 19XR/XRT.

Also on the back of the panel is a keyswitch. Its positions are labeled "Program" & "Protection". Program allows setpoints to be entered. Protection mode is the normal operating mode and the only mode in which the motor should be operated.

If the keyswitch is in the "Program" mode, the front panel pushbutton labels colored blue apply. If the keyswitch is in the "Protection" position, the white pushbutton labels apply.

The "Help" pushbutton gives a complete description of the selected item in a scrolling fashion.

PROGRAMMING:

Step 1. The motor should be stopped during any programming changes.

Step 2. Turn the keyswitch to the "Program" mode.

Step 3. Use the "Step" pushbutton to advance the display to the point you want to change. "Reset" will return you to the first point.

Step 4. Use the "Increase" and "Decrease" pushbuttons to change the setpoint to the desired value. Certain setpoints are mode descriptions rather than numerical values. The increase and decrease buttons will step through these modes.

Step 5. Return the keyswitch to the "Protection" position.



Carrier

A United Technologies Company

REPLACEMENT COMPONENTS DIVISION

SERVICE BULLETIN

SUBJECT: IQ-1000 II Default Settings and Calibration	NUMBER: C9632 DATE: 9-16-96 SUPERSEDES:
MODELS AFFECTED: All 19XR/XRT Chillers, 19XL & 23XL Chillers Shipped After 10-28-96 with Unit Mounted Starters	DATE: PAGE: 3 OF: 13

VIEWING METERED VALUES IN THE PROTECTION MODE:

To view metered values use the "Step Up" and Step Down" buttons.

The "Reset" button will clear trip conditions (if any) or, if no trip condition exists, RESET will return the display to the "Motor Status" point. There are 32 operating values in addition to Status of Motor.

The first 8 metered values in order as you would see them using the "Step down" button are:

- STATUS OF MOTOR
- PHASE A CURRENT IN AMPS
- PHASE B CURRENT IN AMPS
- PHASE C CURRENT IN AMPS
- GROUND FAULT CURRENT IN AMPS
- PERCENT FULL LOAD CURRENT PHASE A
- PERCENT FULL LOAD CURRENT PHASE B
- PERCENT FULL LOAD CURRENT PHASE C

VIEWING SETPOINTS WHILE IN PROTECTION MODE:

The button that is used to step from point to point when in programming mode is also used to step through the setpoints when in protection mode. In this case the setpoints can only be viewed. They cannot be changed.

To view setpoints simply press the "Setpoints" button repeatedly until the desired setpoint is reached.

To return to viewing metered points, press the "Step Up" or "Step Down" button until the desired point is in view.

Note that when setpoints are being viewed while in the protection mode, the Program LED blinks continuously. This is to alert you that you are viewing a setpoint and not a metered value.



Carrier

A United Technologies Company

REPLACEMENT COMPONENTS DIVISION

SERVICE BULLETIN

SUBJECT: IQ-1000 II Default Settings and Calibration	NUMBER: C9632 DATE: 9-16-96 SUPERSEDES:
MODELS AFFECTED: All 19XR/XRT Chillers, 19XL & 23XL Chillers Shipped After 10-28-96 with Unit Mounted Starters	DATE: PAGE: 4 OF: 13

CALIBRATION OF THE PIC CONTROL:

The Motor Current Setting on the chiller LID panel is calibrated at two points: both with the machine not running and with the machine running at 70-100% RLA This calibration is performed because the IQ-1000 II creates a 4-20 mA signal which must be converted (by RES1 25 Ohm Resistor) to 0.1-0.5 Volts to the SMM. (lower left section of Figure A)

The calibration procedure is performed on the PIC Control as follows:

Zero Point (performed with machine not running but power supplied to IQ-1000 II and PIC Control):

Step 1. Make sure that the compressor motor rated load amps in the Service1 table has been configured.

Step 2. Enter the Status1 table, highlight the amps value, and press SELECT. Press INCREASE or DECREASE to bring the amps value on the LID to 0. Press ENTER when completed.

Range Point (performed with machine running):

NOTE: With a free-standing starter that has current transformers, this calibration can be performed as shown in the Start-up, Operation, and Maintenance Instructions for the chiller.

Step 1. Start the compressor and establish a steady motor current value between 70% and 100% RLA, as read on the IQ-1000 II, by manually overriding the guide vane target value on the LID and setting the chilled water setpoint to a low value. Do not exceed 105% of the nameplate RLA.

Step 2. When a steady motor current value in the desired range is met, compare the compressor motor amps value on the Status1 table to the amps reading on the IQ-1000 II (take the average of the 3 legs). Adjust the amps value on the LID to the value seen if there is a difference. Highlight the amps value and then press SELECT. Press INCREASE or DECREASE to bring the value to that indicated on the ammeter. Press ENTER when equal.



Carrier

A United Technologies Company

REPLACEMENT COMPONENTS DIVISION

SERVICE BULLETIN

SUBJECT: IQ-1000 II Default Settings and Calibration	NUMBER: C9632 DATE: 9-16-96 SUPERSEDES:
MODELS AFFECTED: All 19XR/XRT Chillers, 19XL & 23XL Chillers Shipped After 10-28-96 with Unit Mounted Starters	DATE: PAGE: 5 OF: 13

Step 3. Make sure the target guide vane position is released into AUTOMATIC mode, and the chilled water setpoint is returned to the desired value.

SUMMARY OF IQ-1000 II DEFAULT SETTINGS

<u>ITEM</u>	<u>PROGRAM MENU DISPLAY(TOGGLES)</u>	<u>SELECTED VALUE</u>
0	SVER XX	N/A
1	1/3 PHASE	3
2	RTD IN C/F	0
3	WD T XXX	0
4	MB T XXX	0
5	LB T XXX	0
6	AX T XXX	0
7	WD A XXX	0
8	MB A XXX	0
9	LB A XXX	0
10	AX A XXX	0
11	GF XX	5
12	GFS D XX	5
13	GFR D XX	2
14	IOC ON/IOC OFF	ON
15	IOC XXXX	1000%
16	IOCSD XX	2
17	LRC XXXX	*MOTOR DATA
18	LRT XX	3
19	UTC XXX	108%
20	I2TA XXX	75%
21	MAN RST/AUTO RST	MAN RST
22	JM A XXXX	115%
23	JM T XXXX	150%
24	JAMS XX	10
25	JAMR XXX	1
26	UL A XX	0
27	UL T XX	0
28	ULSD XXX	1
29	ULRD XX	1



Carrier

A United Technologies Company

REPLACEMENT COMPONENTS DIVISION

SERVICE BULLETIN

SUBJECT: IQ-1000 II Default Settings and Calibration

NUMBER: C9632

DATE: 9-16-96

SUPERSEDES:

DATE:

PAGE: 6 **OF:** 13

MODELS AFFECTED: All 19XR/XRT Chillers, 19XL & 23XL Chillers Shipped After 10-28-96 with Unit Mounted Starters

<u>ITEM</u>	<u>PROGRAM MENU DISPLAY(TOGGLES)</u>	<u>SELECTED VALUE</u>
30	PU A XX	10%
31	PURD XXX	60
32	I2T TRIP/2 SEC	2 SEC
33	ST/T XX	1
34	T/ST X	0
35	OP COUNT/RST OCNT	OP COUNT
36	RUN TIME/RST RT	RUN TIME
37	TRNC XXX	50%
38	TRNT XXX	10
39	TRN TOUT/TRP TOUT	TRN TOUT
40	INSQ XX	2
41	ABKS XXX	0
42	FLA XXXX	*MOTOR DATA
43	FREQ 50/FREQ 60	*MOTOR DATA
44	MODE 1/MODE 2	MODE 2
45	NON REV/REV	NON REV
46	REM TRIP/REM RST/DIF TRIP/ MTR STOP	REM TRIP
47	MAX 100/MAX 125/MAX%12T/ MAXWRD	MAX 125%
48	AUX ALL/IOC/I2T/GFLT/JAM/ UL/MBT/LBT/WT/REV	GFLT
49	TRIP CNT/TRIP RST	TRIP CNT
50	MX R-EBL/MX RESET/MX R-DBL	MX R-DBL
51	STOP PGM/RUN PGM	STOP PGM
52	X/5 XXXX CT RATIO	CT RATIO

NOTE:* Data must be obtained from motor information. This data is specific for each machine.

Figure 1

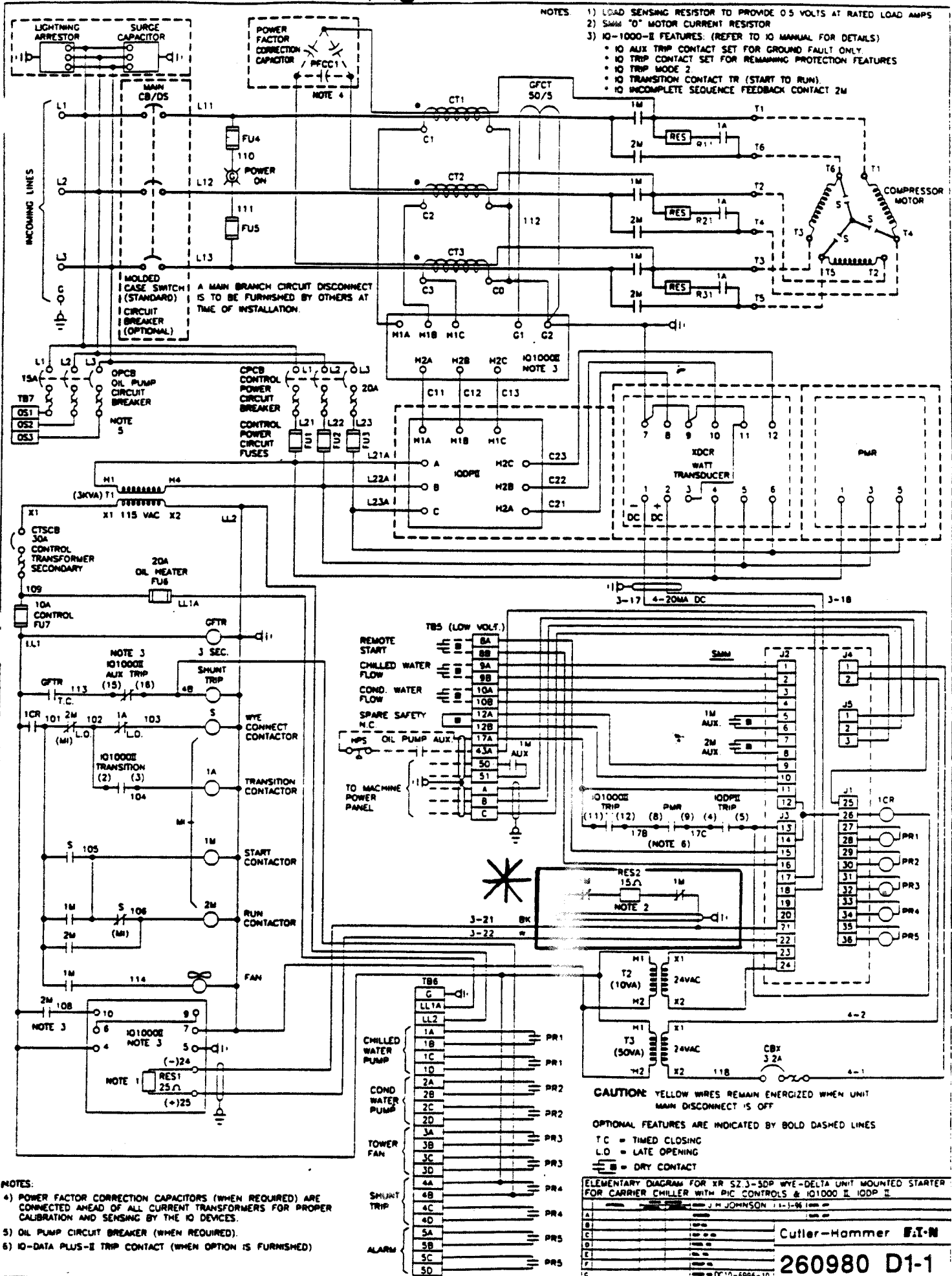

- NOTES:
- 1) LOAD SENSING RESISTOR TO PROVIDE 0.5 VOLTS AT RATED LOAD AMPS
 - 2) Select "D" MOTOR CURRENT RESISTOR
 - 3) IO-1000-E FEATURES: (REFER TO IO MANUAL FOR DETAILS)
 - IO AUX TRIP CONTACT SET FOR GROUND FAULT ONLY
 - IO TRIP CONTACT SET FOR REMAINING PROTECTION FEATURES
 - IO TRIP MODE 2
 - IO TRANSITION CONTACT TR (START TO RUN)
 - IO INCOMPLETE SEQUENCE FEEDBACK CONTACT 2M

- NOTES:
- 4) POWER FACTOR CORRECTION CAPACITORS (WHEN REQUIRED) ARE CONNECTED AHEAD OF ALL CURRENT TRANSFORMERS FOR PROPER CALIBRATION AND SENSING BY THE IO DEVICES.
 - 5) OIL PUMP CIRCUIT BREAKER (WHEN REQUIRED).
 - 6) IO-DATA PLUS-E TRIP CONTACT (WHEN OPTION IS FURNISHED)

CAUTION: YELLOW WIRES REMAIN ENERGIZED WHEN UNIT MAIN DISCONNECT IS OFF

OPTIONAL FEATURES ARE INDICATED BY BOLD DASHED LINES
 TC = TIMED CLOSING
 L.O. = LATE OPENING
 = DRY CONTACT

ELEMENTARY DIAGRAM FOR XR 52.3-SDP WYE-DELTA UNIT MOUNTED STARTER FOR CARRIER CHILLER WITH PIC CONTROLS & IO1000 E IODP II

A	100V	100V
B	100V	100V
C	100V	100V
D	100V	100V
E	100V	100V
F	100V	100V

Cutler-Hammer **F.I.N.**
260980 D1-1
© 1985-1986

IO 1000 ■ OVERLOAD CONNECTION

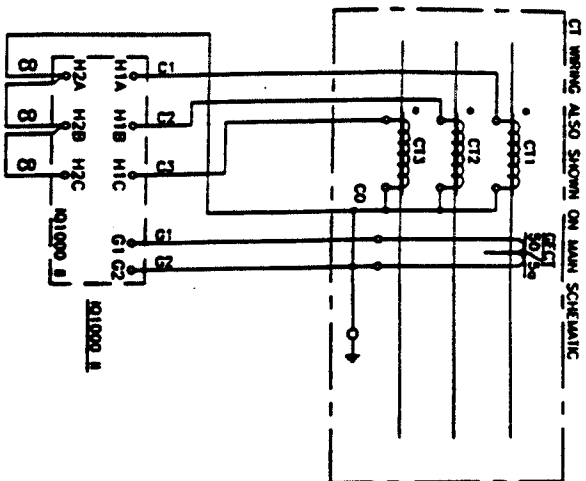

IO 1000 ■ OVERLOAD w/ METERING OPTION

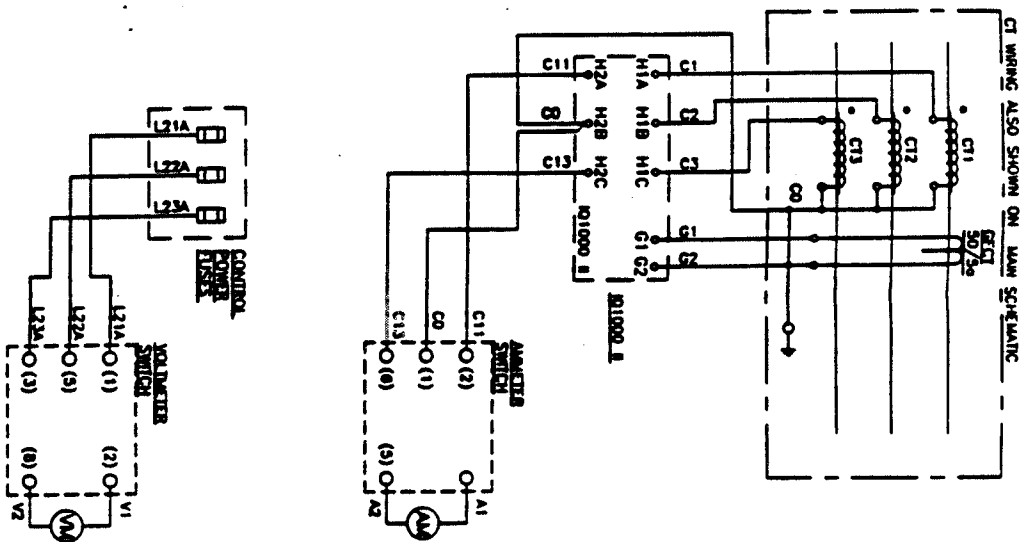

IO 1000 ■ OL w/ IO DATA PLUS ■

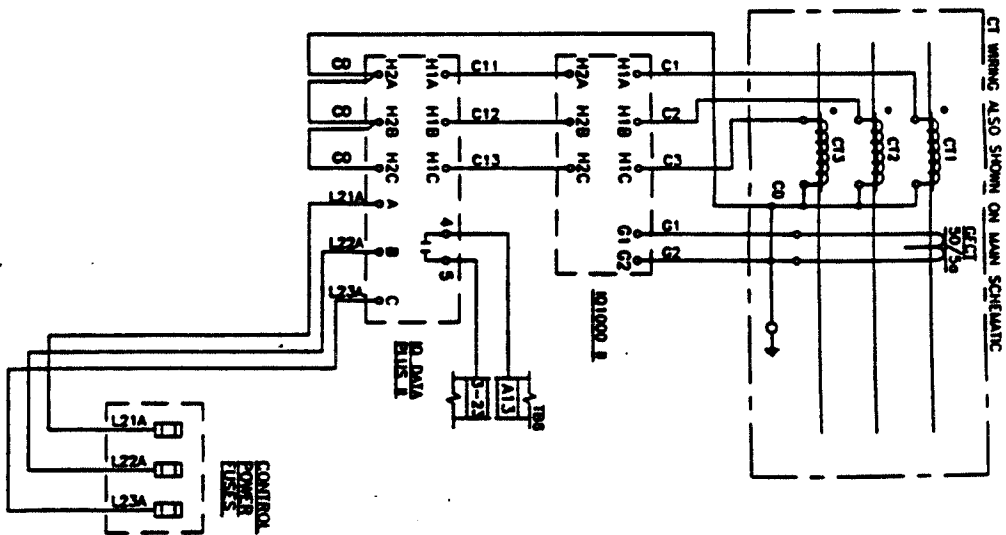

OVERLOAD CONNECTION WITH OPTIONS (CONTINUED)

REV	DATE	BY	CHKD	DESCRIPTION
1				
2				
3				
4				
5				
6				
7				
8				
9				
10				

Page 3 of 3
Culler-Hammer EAT-18
261017 D1-2

IQ-1000 II

CARRIER IQ-1000-II SET POINTS.

TD 17297B

Table 8.B
SET POINT RECORD SHEET

Program Date _____ Control Schematic _____
 Unit ID/Starter Type _____ W. Order# _____
 Motor HP _____ Mfr. _____ Serial _____ Volts _____
 FLA _____ LRA _____ Stall Time _____ Accel Time _____
 SF _____ RTD Type _____ Other _____

Item No.	Program Menu Display ^{1,2}	Selected Value	Set Point Ranges Selection	Set Point Disable Value
0	S VER XX SOFTWARE VERSION NUMBER ³	N/A	N/A	
1	X PHASE SINGLE PHASE TEST MODE OR THREE PHASE PROTECTION MODE	3	Toggles between 1 PHASE and 3 PHASE	
2	RTD IN X RTD TEMP IN DEGREES F OR DEGREES C	0	Toggles between RTD IN F and RTD IN C	
3	WD T XXX WINDING TEMP TRIP IN DEGREES	0	0-199°C / 32-390°F (1° incre.)	
4	MB T XXX MOTOR BEARING TRIP IN DEGREES	0	0-199°C / 32-390°F (1° incre.)	
5	LB T XXX LOAD BEARING TRIP IN DEGREES	0	0-199°C / 32-390°F (1° incre.)	
6	AX T XXX AUXILIARY TRIP IN DEGREES	0	0-199°C / 32-390°F (1° incre.)	
7	WD A XXX WINDING TEMP ALARM IN DEGREES	0	0-199°C / 32-390°F (1° incre.)	
8	MB A XXX MOTOR BEARING ALARM IN DEGREES	0	0-199°C / 32-390°F (1° incre.)	
9	LB A XXX LOAD BEARING ALARM IN DEGREES	0	0-199°C / 32-390°F (1° incre.)	
10	AX A XXX AUXILIARY ALARM IN DEGREES	0	0-199°C / 32-390°F (1° incre.)	
11	GF XX GROUND FAULT TRIP LEVEL IN AMPS	* 5	1-12 amps (1 amp. incre.)	12
12	GFS D XX GROUND FAULT START DELAY IN CYCLES	5	1-20 AC cycles (1 cycle incre.)	
13	GFR D XX GROUND FAULT RUN DELAY IN CYCLES	2	0-10 AC cycles (1 cycle incre.)	0
14	IOC XX ENABLE OR DISABLE INSTANTANEOUS OVERCURRENT FUNCTION	ON	Toggles between IOC ON and IOC OFF displays	IOC OFF
15	IOC XXXX INSTANTANEOUS OVERCURRENT IN % FLA ⁵	1000%	300-1600% (1% incre.)	

TD 17297B

IQ-1000 II

Table 8.B
SET POINT RECORD SHEET
(Cont'd)

Item No.	Program Menu Display ^{1,2}	Selected Value	Set Point Ranges Selection	Set Point Disable Value
16	IOCSX XX INSTANTANEOUS OVERCURRENT START DELAY IN CYCLES	2	1-20 cycles (1 cycle incre.)	
17	LRC XXXX LOCKED ROTOR CURRENT IN % FLA	LR 7 Motor Info	300 to 1200% (1% incre.)	
18	LRT XX MAXIMUM ALLOWABLE STALL TIME IN SECONDS	3	1-60 sec. (1 sec. incre.)	
19	UTC XXX ULTIMATE TRIP CURRENT IN % FLA	108%	85-125% (1% incre.)	
20	IFTA XXX IFT ALARM LEVEL IN % IFT TRIP	75%	60-100% (1% incre.)	100
21	MAN RST* AUTO RST* AUTO OR MANUAL IFT RESET	* MAN	Toggles between MAN RST and AUTO RST displays	
22	JM A XXXX JAM ALARM LEVEL IN % FLA	* 115%	100-1200% (1% incre.)	1200
23	JM T XXXX JAM TRIP LEVEL IN % FLA	* 150%	100-1200% (1% incre.)	1200*
24	JAMS XX JAM START DELAY IN SECONDS	* 10	0-60 sec. (1 sec. incre.)	
25	JAMR XXX JAM RUN DELAY IN SECONDS	1	0-240 sec. (1 sec. incre.)	240
26	UL A XX UNDERLOAD ALARM LEVEL IN % FLA	* 0	0-90% (1% incre.)	0
27	UL T XX UNDERLOAD TRIP LEVEL IN % FLA	* 0	0-90% (1% incre.)	0
28	ULSD XXX UNDERLOAD START DELAY IN SECONDS	1	0-100 sec. (1 sec. incre.)	
29	ULRD XX UNDERLOAD RUN DELAY IN SECONDS	1	1-10 sec. (1 sec. incre.)	1
30	PU A XX PHASE UNBALANCE ALARM LEVEL	10%	10-50% (1% incre.)	50*
31	PURD XXX PHASE UNBALANCE ALARM RUN DELAY IN SECONDS	60	0-240 sec. (1 sec. incre.)	
32	IFT TRIP* 2 SEC* 2 SECOND DELAY OR IFT TRIP ON PHASE UNBALANCE	2	Toggles between IFT TRIP and 2 SEC displays	
33	ST/T XX STARTS PER TIME ALLOWED	1	1-10 starts/ time (incre. of 1)	1

Table 8.B
SET POINT RECORD SHEET
(Cont'd)

Item No.	Program Menu Display ^{1,2}	Selected Value	Set Point Ranges Selection	Set Point Disable Value
34	T/ST X TIME ALLOWED FOR STARTS COUNT IN MINUTES	0	0 to 240 minutes duration (1 minute incr.)	0
35	OP COUNT [*] RST OCNT [*] RESET FOR OPERATIONS COUNTER	OP COUNT	Toggles between OP COUNT and RST OCNT	OP COUNT
36	RUN TIME [*] RST RT [*] RESET FOR RUN TIME	RUN TIME	Toggles between RUN TIME and RST RT displays	RUN TIME
37	TRNC XXX MOTOR START TRANSITION CURRENT LEVEL IN % FLA	50%	50-150% (1% incre.)	150
38	TRNT XXX MOTOR START TRANSITION TIME IN SECONDS	10	0-240 sec. (1 sec. incre.)	0
39	TRN TOUT [*] TRP TOUT [*] TRANSITION OR TRIP ON TIME OUT	TRANS- ITION *	Toggles between TRN TOUT and TRP TOUT displays	TRN TOUT
40	INSQ XX INCOMPLETE SEQUENCE REPORT BACK TIME IN SECONDS	2	1-60 sec. (1 sec. incre.)	
41	ABKS XXX ANTI-BACKSPIN DELAY TIME IN SECONDS	0	0-600 sec.	0
42	FLA XXXX FULL-LOAD AMPS	MOTOR DATA	10-3000 amps (1 amp incre.)	
43	FREQ 50 [*] FREQ 60 [*] 50 OR 60 HERTZ LINE FREQUENCY	MOTOR DATA	Toggles between FREQ 50 and FREQ 60 displays	
44	MODE 1 [*] MODE 2 [*] TRIP MODE 1 — TRIP RELAY ENERGIZES ON TRIP CONDITION [*] TRIP MODE 2 — TRIP RELAY ENERGIZES ON POWER UP AND DE-ENERGIZES ON TRIP CONDITION [*]	MODE 2	Toggles between MODE 1 and MODE 2	
45	NON REV [*] REV [*] REVERSING OR NONREVERSING STARTER	NR	Toggles between REV and NONREV displays	

TD 17297B

Table 6.B
SET POINT RECORD SHEET
(Cont'd)

Item No.	Program Menu Display ^{1,2}	Selected Value	Set Point Ranges Selection	Set Point Disable Value
46	REM RST ⁴ REM TRIP ⁴ DIF TRIP ⁴ MTR STOP ⁴ RST DBL ⁴ REMOTE INPUT — RST FOR REMOTE RESET — TRIP FOR REMOTE TRIP — DIF TRIP FOR DIFFERENTIAL TRIP — MTR STOP FOR MOTOR STOP DETECTION — RST DBL FOR RESET DISABLE	REM TRIP	Toggles between REM TRIP, REM RST, DIF TRIP, MTR STOP	
47	MAX XXX ⁴ 4-20 MA MAX OUTPUT — 100 FOR 100 PERCENT FLA — 125 FOR 125 PERCENT FLA — %I2T FOR PERCENT I2T TRIP — WRD FOR MAXIMUM WINDING RTD TEMP	MAX 125%	Toggles between MAX100, MAX125, MAX%i2T and MAXWRD displays	
48	AUX XXXX TRIP STATE FOR AUX TRIP RELAY	GFLT	Toggles between ALL, IOC, I2T, GFLT, JAM, UL, MBT, LBT, WT and REV displays ⁴	
49	TRIP XXX RESET FOR NUMBER OF TRIPS	TRIP CNT	Toggles between TRIP CNT and TRIP RST displays ⁴	TRIP CNT
50	MAX XXX RESET FOR MAXIMUM VALUES	MXR DBL	Toggles between MX R-EBL, MX RESET and MX R-DBL displays ⁴	MX R-DBL
51	XXX PGM ENABLE UNIT TO BE PROGRAMMED WHILE MOTOR IS RUNNING	STOP PGM	Toggles between RUN PGM and STOP PGM	
52	X/5 XXXX CT RATIO — X TURNS TO 5	CT RATIO	Available CT turns:5 ratios are: 10, 20, 25, 40, 50, 75, 100, 125, 150, 200, 250, 300, 400, 500, 600, 800, 1000, 1200, 1500, 2000, 2500, 3000, 4000	

NOTES:

- The letters X used here represent the setpoint variables.
- Press the Help pushbutton to initiate the help display of the complete message shown here. The display scrolls right to left.
- The software version number is used by Westinghouse. There is no selection associated with it. All correspondence with Westinghouse should refer to the specific software version number installed in the IQ-1000 II.
- One of these choices must be selected.
- IOC trip setting should be lower than your Fuse Interrupting Rating or your Contactor Withstand Rating.
- Set start and run delays to maximum values to disable trip/alarm functions.