



**Super Remote Meter Interface (RMI) Board
For Use With
GV3000/SE and VTAC 7 Drives**

M/N 2SI3000

M/N 2SI3000E

Instruction Manual D2-3341-2

Rockwell
Automation

The information in this manual is subject to change without notice.

Throughout this manual, the following notes are used to alert you to safety considerations:



ATTENTION: Identifies information about practices or circumstances that can lead to personal injury or death, property damage, or economic loss.

Important: Identifies information that is critical for successful application and understanding of the product.

The thick black bar shown on the outside margin of this page will be used throughout this instruction manual to signify new or revised text or figures.



ATTENTION: Only qualified electrical personnel familiar with the construction and operation of this equipment and the hazards involved should install, adjust, operate, or service this equipment. Read and understand this manual and other applicable manuals in their entirety before proceeding. Failure to observe this precaution could result in severe bodily injury or loss of life.

ATTENTION: Do not install modification boards with power applied to the drive. Disconnect and lock out incoming power before attempting such installation. Failure to observe this precaution could result in severe bodily injury or loss of life.

ATTENTION: DC bus capacitors retain hazardous voltages after input power has been disconnected. After disconnecting input power, wait five minutes for the DC bus capacitors to discharge and then check the voltage with a voltmeter to ensure the DC bus capacitors are discharged before touching any internal components. Failure to observe this precaution could result in severe bodily injury or loss of life.

ATTENTION: The user is responsible for conforming with all applicable local, national, and international codes. Failure to observe this precaution could result in damage to, or destruction of, the equipment.

ATTENTION: The RMI board contains components that are static-sensitive. An anti-static wrist band should be worn by any person who touches the board's components, connectors, or leads. Failure to observe this precaution could result in damage to the RMI board.

CONTENTS

Chapter 1	Introduction	
1.1	Where to Find Additional Information	1-1
1.2	Getting Assistance from Reliance Electric.....	1-2
Chapter 2	Mechanical/Electrical Description	
2.1	Status LED	2-1
2.2	Terminal Strip Signals	2-2
2.2.1	Digital Inputs	2-2
2.2.2	Digital Outputs.....	2-2
2.2.3	Relay Outputs	2-3
2.2.4	Analog Input	2-3
2.2.5	Analog Outputs	2-3
2.2.6	Frequency Input	2-3
Chapter 3	Installation	
3.1	Installing the RMI Board in 1 to 5HP @ 460VAC Drives	3-4
3.2	Installing the RMI Board in 7.5 to 10 HP @ 460VAC Drives	3-8
3.3	Installing the RMI Board in 1 to 20HP @ 230VAC Drives	3-12
3.4	Installing the RMI Board in 30 to 100HP @ 230VAC and 75 to 200 @ 460VAC Drives	3-16
3.5	Installing the RMI Board in 15 to 25HP and 25 to 60HP @ 460VAC Drives	3-21
3.6	Installing the RMI Board in 50 to 100HP and 100 to 150HP @ 460VAC Drives (GV3000/SE Drives Only)	3-26
3.7	Installing the RMI Board in 200 to 400 HP @ 460VAC Drives	3-31
3.8	Installing the RMI Board in 2 to 43 Amp GV3000/SE Bookshelf Drives	3-34
3.9	Wiring to the RMI Board Terminal Strip	3-41
Chapter 4	Programming Reference	
4.1	RMI Parameter Descriptions	4-2
4.2	Selecting the RMI Board as the Trim Reference Source.....	4-15
Chapter 5	Troubleshooting Guidelines	
5.1	Fault Codes	5-1
Appendix A	Technical Specifications	A-1
Appendix B	Alphabetical Listing of RMI Parameters.....	B-1
Index	Index-1

List of Figures

Figure 2.1 – RMI Board	2-1
Figure 2.2 – Digital Input Circuit	2-2
Figure 2.3 – Digital Output Circuit.....	2-2
Figure 3.1 – DC Bus Voltage Terminals (1 to 5HP @ 460VAC)	3-5
Figure 3.2 – RMI Board Location in 1 to 5HP @ 460VAC Drives	3-6
Figure 3.3 – DC Bus Voltage Terminals (7.5 to 10HP @ 460VAC)	3-9
Figure 3.4 – RMI Board Location in 7.5 to 10HP Drives	3-10
Figure 3.5 – DC Bus Voltage Terminals (1 to 20HP @ 230VAC)	3-13
Figure 3.6 – 1 to 20HP @ 230 V GV3000/SE Drive	3-15
Figure 3.7 – DC Bus Voltage Terminals (30 to 100HP @ 230VAC and 75 to 200HP @ 460VAC).....	3-17
Figure 3.8 – Location of Terminal Cover and Regulator Board Cover in 30 to 100HP @ 230VAC and 75 to 200HP @ 460VAC Drives	3-18
Figure 3.9 – Regulator Board’s Connection to RMI Board, Keypad, and Base Board.....	3-20
Figure 3.10 – DC Bus Voltage Terminals (15 to 25 HP @ 460VAC)	3-22
Figure 3.11 – DC Bus Voltage Terminals (25 to 60 HP @ 460VAC)	3-22
Figure 3.12 – RMI Board Location in 15 to 25 HP @ 460VAC Drives	3-23
Figure 3.13 – RMI Board Location in 25 to 60 HP @ 460VAC Drives	3-24
Figure 3.14 – Drive Components and Locations (50 to 100HP @ 460VAC)	3-28
Figure 3.15 – Drive Components and Locations in 100 to 150HP @ 460VAC Drives.....	3-29
Figure 3.16 – RMI Board Location in 200 to 400HP @ 460VAC Drives	3-32
Figure 3.17 – 2 to 15 Amp GV3000/SE Bookshelf Drive	3-37
Figure 3.18 – 24 to 30 Amp GV3000/SE Bookshelf Drive	3-38
Figure 3.19 – 43 Amp GV3000/SE Bookshelf Drive	3-39
Figure 3.20 – Installing the RMI Board in a Bookshelf Drive	3-40
Figure 3.21 – Terminal Connections on the RMI Board	3-41
Figure 4.1 – Parameter Menu Structure	4-1
Figure 4.2 – PI Regulator Operating Modes.....	4-5
Figure 4.3 – Torque or Current Limit Selection.....	4-6
Figure 4.4 – Speed Reference Options	4-8
Figure 4.5 – Speed Level 1, 2, and 3.....	4-11
Figure 4.6 – Low Speed.....	4-11
Figure 4.7 – Speed Reached.....	4-12
Figure 4.8 – Current Level 1, 2, and 3.....	4-12
Figure 4.9 – Torque Level 1, 2, and 3.....	4-13
Figure 4.10 – Speed Reference.....	4-14

List of Tables

Table 2.1 – Jumper Selections for Digital Output Supply Source	2-2
Table 2.2 – Relay Contacts	2-3
Table 2.3 – Analog Outputs	2-3
Table 3.1 – Locating the Appropriate Installation Procedure	3-1
Table 3.2 – Model Numbers for 1 to 5HP @ 460VAC Drives.....	3-4
Table 3.3 – Model Numbers for 7.5 to 10 HP @ 460VAC Drives.....	3-8
Table 3.4 – Model Numbers for 1 to 20HP @ 230VAC Drives.....	3-12
Table 3.5 – Model Numbers for 30 to 100 HP @ 230 VAC and 75 to 200HP @ 460VAC Drives	3-16
Table 3.6 – Model Numbers for 15 to 25HP and 25 to 60HP @ 460VAC Drives ..	3-21
Table 3.7 – Model Numbers for 200 to 400 HP @ 460VAC Drives.....	3-31
Table 3.8 – Model Numbers for 2 to 43 Amp GV3000/SE Bookshelf Drives.....	3-34
Table 3.9 – Wiring Signal and Control I/O to the RMI Board Terminal Strip	3-42
Table 4.1 – Analog Output Source Selections for r.001, r.004, and r.007	4-2
Table 4.2 – Regulator Operating Modes.....	4-4
Table 4.3 – Digital Input Configuration Selections for r.030	4-6
Table 4.4 – Preset Speed Digital Inputs	4-10
Table 4.5 – Digital Outputs and Relay Outputs Configuration Selections	4-10
Table 5.1 – RMI Fault Codes	5-1

Introduction

The optional Remote Meter Interface (RMI) board provides an extended set of terminal strip inputs and outputs for the GV3000/SE™ drive and the VTAC 7™ HVAC drive. When the drive control source is the terminal strip (P.000 = rE), the RMI board can be used to provide additional speed reference selections. The RMI board also provides an outer PI regulator that is used to adjust trim. An optional adjustable torque (vector) or current (V/Hz) limit is available using the RMI board's analog or frequency input.

The RMI board is programmed using a set of parameters (r.---) contained in the drive's Second Menu. Note that version 5.0 software or later is required to use the RMI board.

The RMI board mounts below the Regulator board inside the drive using the parallel bus connector. This connection allows only one option card to be installed. Therefore, it is not possible to install both an RMI board and a network option board in the drive at the same time.

This manual provides installation instructions, RMI parameter descriptions, and troubleshooting guidelines. It is intended for qualified electrical personnel responsible for installing and programming the drive.

1.1 Where to Find Additional Information

This manual describes the RMI board and its associated r parameters. You will also need some of the following manuals, as appropriate for your drive. They describe drive hardware and software:

- GV3000/SE AC General Purpose (Volts/Hertz) and Vector Duty Drive Software Start-Up and Reference Manual (D2-3359)
- GV3000/SE AC Power Modules Hardware Reference, Installation, and Troubleshooting (D2-3360)
- VTAC 7 User's Guide (D2-3372)
- GV3000/SE 230 VAC 1-20 HP General Purpose (Volts/Hertz) and Vector Duty Drive Software Start-Up and Reference Manual (D2-3387)
- GV3000/SE AC Drive Hardware Reference, Installation, and Troubleshooting, 1-20 HP @ 230 VAC (D2-3388)
- GV3000/SE 460 VAC 75-200 HP General Purpose (Volts/Hertz) and Vector Duty Drive Software Start-Up and Reference Manual (D2-3391)
- GV3000/SE AC Drive Hardware Reference, Installation, and Troubleshooting 75-200 HP @ 460 VAC (D2-3392)

- GV3000/SE 230 VAC 30-100 HP General Purpose (Volts/Hertz) and Vector Duty Drive Software Start-Up and Reference Manual (D2-3416)
- GV3000/SE AC Drive Hardware Reference, Installation, and Troubleshooting 30-100 HP @ 230 VAC (D2-3417)
- GV3000/SE AC General Purpose (Volts/Hertz) and Vector Duty Bookshelf Drive Software Start-Up and Reference Manual (D2-3426)
- GV3000/SE AC Bookshelf Power Modules Hardware Reference, Installation, and Troubleshooting (D2-3427)

1.2 Getting Assistance from Reliance Electric

If you have any questions or problems with the products described in this instruction manual, contact your local Reliance Electric sales office. For technical assistance, call 1-800-726-8112.

Mechanical/Electrical Description

The optional RMI board is a printed circuit assembly that mounts inside the drive. It connects to the Regulator board through a flexible ribbon cable and is powered by the drive power supply. Refer to figure 2.1 for the RMI board layout. This figure also shows the factory-set jumper positions.

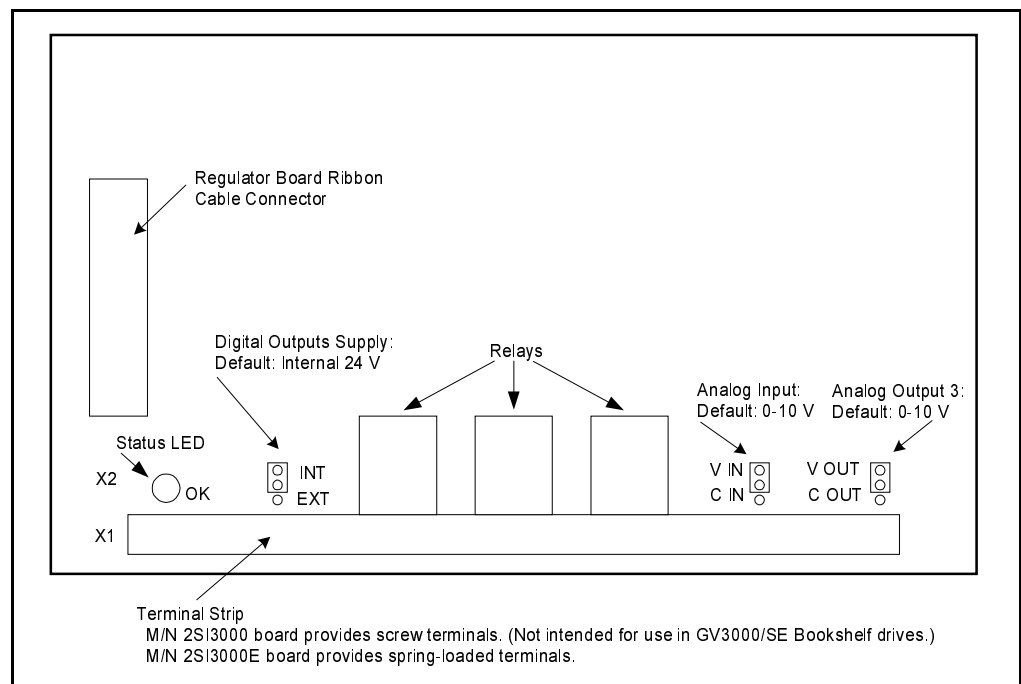

Figure 2.1 – RMI Board

2.1 Status LED

The green LED on the RMI board indicates the status of the RMI board and the communications link between the RMI board and the drive.

If the LED is ...	It indicates that ...
On	Power-up diagnostics are complete and no fault has been detected.
Flashing	The RMI board and the drive are communicating.
Off	The drive is not powered up or a fault has been detected on the RMI board. See chapter 5 for a list of fault codes. (Note that the LED will be off during a reset and during power up.)

2.2 Terminal Strip Signals

The following signals are available at the terminal strip. Refer to figure 3.21 for terminal identification.

2.2.1 Digital Inputs

Four 24 volt DC digital inputs provide additional speed reference options. The inputs are active high. A 24 VDC supply is provided by the RMI board for use with the digital inputs. The supply is short circuit- and overvoltage-protected. See figure 2.2.

Important: This supply should not be used as an external supply for anything other than the four digital inputs.

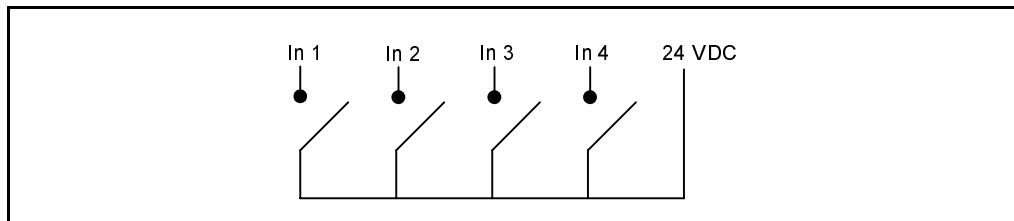

Figure 2.2 – Digital Input Circuit

2.2.2 Digital Outputs

Four 24 volt digital outputs are turned on and off as a result of data comparisons in the drive. Refer to table 3.9 and chapter 4 for the related parameters and programming information.

All digital outputs are source-driven (active high with common ground) and short circuit-protected. Each output has an adjustable time delay that can be programmed as an on-delay or an off-delay. An option to select an external 24 volt supply for increased current capability at the outputs is jumper-selectable as shown in table 2.1. Refer to figure 2.1 for the jumper location.

Table 2.1 – Jumper Selections for Digital Output Supply Source

Jumper Selection	24VDC Supply Source	Output Result
24 V INT	Internal	20mA per output
24 V EXT	External	100mA per output

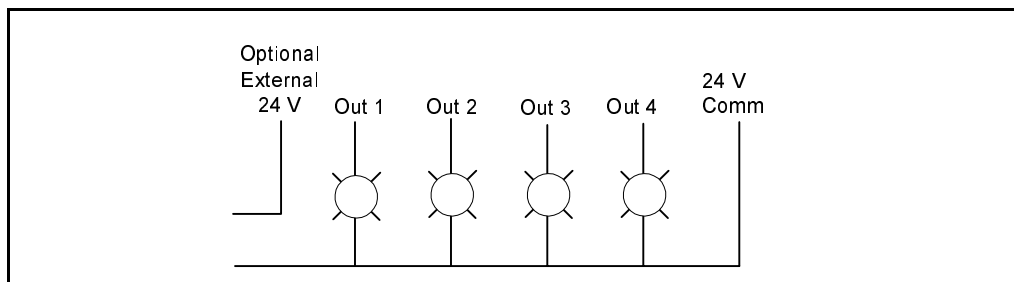

Figure 2.3 – Digital Output Circuit

2.2.3 Relay Outputs

Three relay outputs can be turned on and off as a result of data comparisons in the drive. Refer to table 3.9 and chapter 4 for the related parameters and programming information.

Each output has an adjustable time delay that can be programmed as an on-delay or an off-delay as shown in table 2.2. All contacts are rated at 2A, 24VDC or 250VA, 120VAC.

Table 2.2 – Relay Contacts

Relay 1	Relay 2	Relay 3
1 normally open contact	1 normally open contact and 1 normally closed contact	1 normally open contact and 1 normally closed contact

2.2.4 Analog Input

The analog input is based on a 10-bit analog-to-digital (A/D) converter and is jumper-selected between 0 to 10 volts or 0 to 20 mA (refer to figure 2.1 for the jumper location). Separate connection terminals are provided for voltage input and current input. The inputs are overvoltage-protected. Offset and gain are computed by software.

2.2.5 Analog Outputs

There are three analog output channels configured, as shown in table 2.3. Refer to figure 2.1 for the jumper location. The outputs are short circuit-protected. The output value is modulated over four 1 ms scans to provide 10-bit data resolution.

Table 2.3 – Analog Outputs

Analog Output	Output Range	Jumper Setting
1	0 to +10 V	None
2	-10 V to +10 V	None
3	0 to +10 V	V OUT
	0 to 20 mA	C OUT
	4 to 20 mA	

2.2.6 Frequency Input

The frequency input operates from 0 to 200kHz, 15VDC. The input is single-ended and uses the same common as the analog input.

CHAPTER 3

Installation

Contact Reliance if the drive installation must be in compliance with the European Community Electromagnetic Compatibility Standards.

The RMI board installation procedure differs depending on the drive type. Use table 3.1 to locate the appropriate procedure for your drive.

Table 3.1 – Locating the Appropriate Installation Procedure

Horsepower Rating	Drive Model Number		Use the Procedure in Section ...
	GV3000/SE	VTAC 7	
1	1V21xx 1V24xx	1H21xx 1H22xx	3.3
1	1V41xx 1V44xx	1H41xx 1H42xx	3.1
2	2V21xx 2V24xx	2H21xx 2H22xx	3.3
2	2V41xx 2V44xx	2H41xx 2H42xx	3.1
3	3V21xx 3V24xx	3H21xx 3H22xx	3.3
3	3V41xx 3V44xx	3H41xx 3H42xx	3.1
5	5V21xx 5V24xx	5H21xx 5H22xx	3.3
5	5V41xx 5V44xx	5H41xx 5H42xx	3.1
7.5	7V21xx 7V22xx	7H21xx 7H22xx	3.3
7.5	7V41xx 7V42xx	7H41xx 7H42xx	3.2
10	10V21xx 10V22xx	10H21xx 10H22xx	3.3
10	10V41xx 10V42xx	10H41xx 10H42xx	3.2
15	15V21xx 15V22xx	15H21xx 15H22xx	3.3
15	15V41xx 15V42xx	15H41xx 15H42xx	3.5
20	20V21xx 20V22xx	20H21xx 20H22xx	3.3

Table 3.1 – Locating the Appropriate Installation Procedure (Continued)

Horsepower Rating	Drive Model Number		Use the Procedure in Section ...
	GV3000/SE	VTAC 7	
20	20V41xx 20V42xx	20H41xx 20H42xx	3.5
25	25G41xx 25G42xx 25V41xx 25V42xx	25H41xx 25H42xx 25W21xx	3.5
30	30V20xx	30W21xx	3.4
30	30V41xx 30V42xx	30H41xx 30H42xx	3.5
40	40V20xx	40W21xx	3.4
40	40V41xx 40V42xx	40H41xx 40H42xx	3.5
50	50R41xx	—	3.6
50	50T41xx	—	3.6
50	50V20xx	50W21xx	3.4
50	50V41xx 50V42xx	50H41xx 50H42xx	3.5
60	60G41xx 60G42xx	60H41xx 60H42xx	3.5
60	60V20xx	60W21xx	3.4
75	75R41xx	—	3.6
75	75T41xx	—	3.6
75	75V20xx	75W21xx	3.4
75	75V40xx	75H41xx 75W41xx	3.4
100	100V20xx	100H21xx	3.4
100	100V40xx	100H41xx 100W41xx	3.4
125	125R41xx	—	3.6
125	125V40xx	125H41xx 125W41xx	3.4
150	150V40xx	150H41xx 150W41xx	3.4
200	200V40xx	200W41xx	3.4
200	200V41xx 200V41xxDS	200H41xx	3.7
250	250V41xx 250V41xxDS	250H41xx	3.7
300	300V41xx 300V41xxDS	300H41xx	3.7

Table 3.1 – Locating the Appropriate Installation Procedure (Continued)

Horsepower Rating	Drive Model Number		Use the Procedure in Section ...
	GV3000/SE	VTAC 7	
350	350V41xx 350V41xxDS	350H41xx	3.7
400	400V41xx 400V41xxDS	400H41xx	3.7
2 to 15 Amp	31ER40xx 31ET40xx 38ER40xx 38ET40xx 55ER40xx 55ET40xx 85ER40xx 85ET40xx 126ER40xx 126ET40xx 150ER40xx 150ET40xx	—	3.8
24 to 30 Amp	240ER40xx 240ET40xx 300ER40xx 300ET40xx	—	3.8
43 Amp	430ER40xx 430ET40xx	—	3.8

3.1 Installing the RMI Board in 1 to 5HP @ 460VAC Drives



ATTENTION: Only qualified electrical personnel familiar with the construction and operation of this equipment and the hazards involved should install, adjust, operate, or service this equipment. Read and understand this manual and other applicable manuals in their entirety before proceeding. Failure to observe this precaution could result in severe bodily injury or loss of life.

ATTENTION: The drive is at line voltage when connected to incoming AC power. Disconnect, lock out, and tag all incoming power to the drive before performing the following procedure. Failure to observe this precaution could result in severe bodily injury or loss of life.

ATTENTION: DC bus capacitors retain hazardous voltages after input power has been disconnected. After disconnecting input power, wait five minutes for the DC bus capacitors to discharge and then check the voltage with a voltmeter to ensure the DC bus capacitors are discharged before touching any internal components. Failure to observe this precaution could result in severe bodily injury or loss of life.

ATTENTION: The drive contains printed circuit boards that are static-sensitive. An anti-static wrist band should be worn by any person who touches the drive's components, connectors, or wiring. Erratic machine operation and damage to, or destruction of, equipment can result if this procedure is not followed. Failure to observe this precaution could result in bodily injury.

Use this procedure to install the RMI board in the drives listed in table 3.2.

Table 3.2 – Model Numbers for 1 to 5HP @ 460VAC Drives

GV3000	VTAC 7
1V41xx 1V44xx	1H41xx 1H42xx
2V41xx 2V44xx	2H41xx 2H42xx
3V41xx 3V44xx	3H41xx 3H42xx
5V41xx 5V44xx	5H41xx 5H42xx

Refer to figure 3.2 as you perform the procedure.

If the drive is panel-mounted, this procedure will be easier to perform if the drive is removed from the panel.

Unless otherwise indicated, keep all hardware that is removed. You will need it for reassembly. This includes screws, lock washers, and rivets.

Important: Read and understand the warning labels on the outside of the drive before proceeding.

Step 1. Shut Down the Drive

Step 1.1 Disconnect, lock out, and tag all incoming power to the drive.

Step 1.2 Wait five minutes for the DC bus capacitors to discharge.

Step 1.3 Remove the cover by loosening the four cover screws.

Important: Read and understand the warning labels on the inside of the drive before proceeding.

Step 2. Verify That the DC Bus Capacitors are Discharged

Step 2.1 Use a voltmeter to verify that there is no voltage at the drive's AC input power terminals (R/L1, S/L2, T/L3).

Step 2.2 Ensure that the DC bus capacitors are discharged. To check DC bus potential:

- a. Stand on a non-conductive surface and wear insulated gloves.
- b. Use a voltmeter to measure the DC bus potential at the DC bus power terminals as shown in figure 3.1.

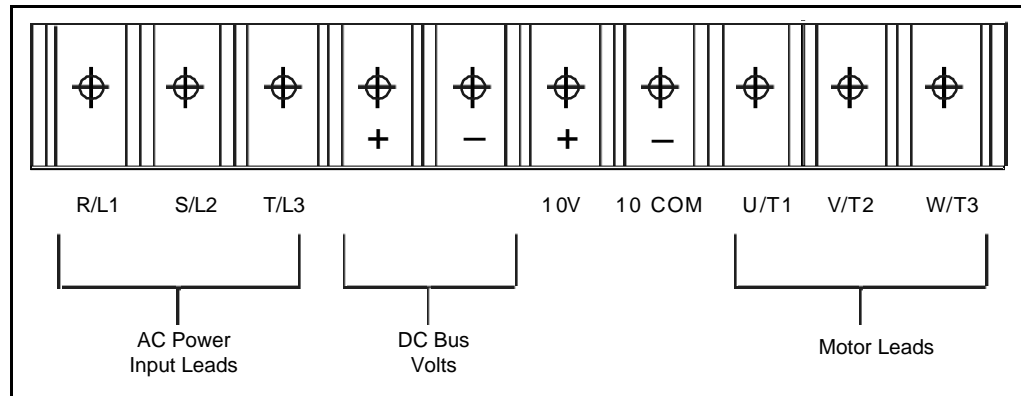

Figure 3.1 – DC Bus Voltage Terminals (1 to 5HP @ 460VAC)

Step 3. Remove the Keypad Bracket from the Drive

Step 3.1 Record connections to the Regulator board terminal strip if they must be disconnected to remove the keypad bracket.

Step 3.2 Use a magnetic screwdriver to remove the three M4 x 10 screws that fasten the bottom of the keypad support bracket to the drive heat sink.

Important: The keypad support bracket is connected to the drive by wiring. Do not lift the bracket out completely, because this can damage or pull out wiring.

Step 3.3 Spread the retaining clips on the 26-conductor Regulator board ribbon cable connector to disconnect it from the Current Feedback board. The Current Feedback board is located on the right below the keypad.

Step 3.4 Move the keypad support bracket aside.

Step 3.5 Pinch the retaining clip that is through the center of the Current Feedback board and carefully pull out the Current Feedback board.

Step 3.6 Unplug the internal fan assembly power connector (CONN7) from the drive.

Step 4. Install the RMI Board in the Keypad Bracket



ATTENTION: The RMI board contains components that are static-sensitive. An anti-static wrist band should be worn by any person who touches the board's components, connectors, or wiring. Failure to observe this precaution could result in damage to the RMI board.

Refer to figure 3.2 for component locations.

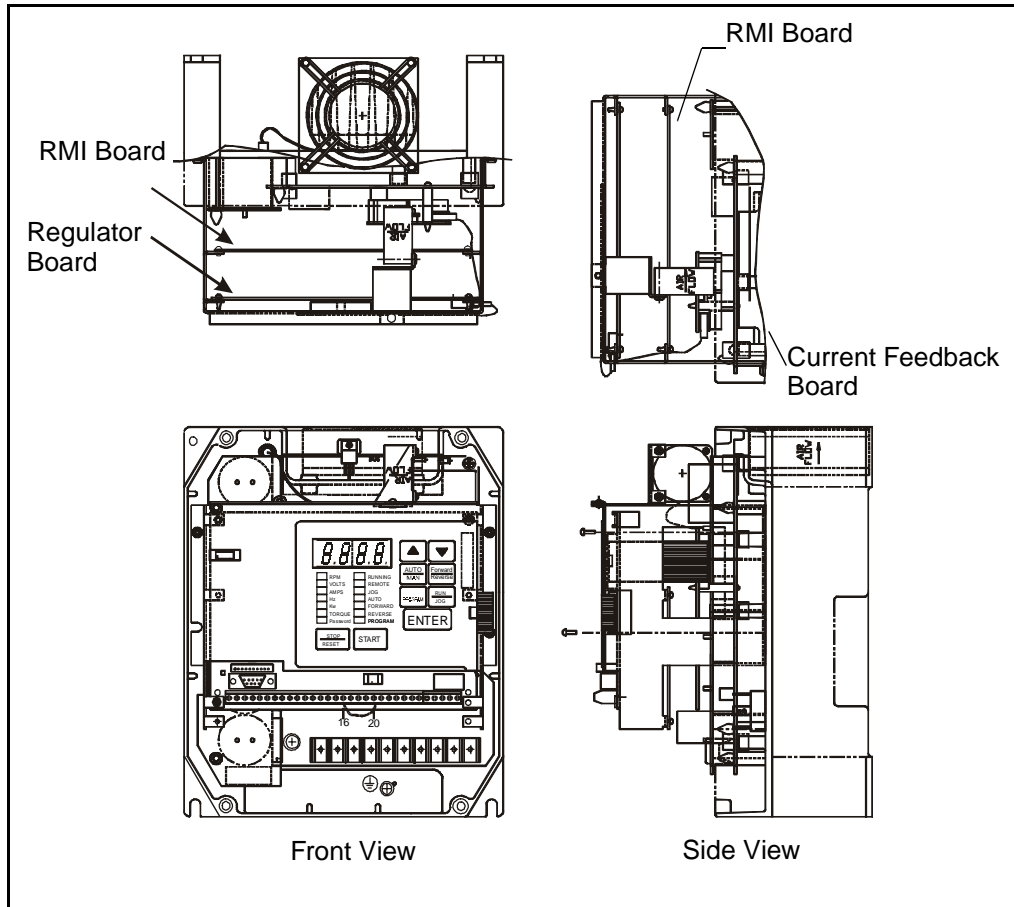

Figure 3.2 – RMI Board Location in 1 to 5HP @ 460VAC Drives

- Step 4.1 Remove the RMI board from its anti-static wrapper and verify that the jumper settings are correct. Refer to figure 2.1 for jumper locations and appendix A for jumper settings.
- Step 4.2 Align the key on the Regulator board's 34-conductor ribbon cable connector with the slot in the RMI board's connector. Press the ribbon cable connector in until it locks into position.
- Step 4.3 Route the 26-conductor ribbon cable for the Current Feedback board out of the side of the keypad bracket.
- Step 4.4 Align the RMI board on the four mounting tabs on the keypad bracket. Make sure that the ribbon cable is not pinched between the keypad bracket and the RMI board.

Step 4.5 Fasten the RMI board to the right side of the keypad bracket using the two metal M3 screws and lock washers for proper grounding. Fasten the left side using the two 6-32 screws and lock washers for proper grounding.

Important: You must use the lock washers to properly ground the RMI board. Improper grounding of the RMI board can result in erratic operation of the drive.

Step 5. Reinstall the Keypad Bracket in the Drive

Step 5.1 Reconnect the internal fan assembly power connector (CONN7) to the drive. Align the key on the connector with the slot in the receptacle. Press the connector into position.



ATTENTION: Proper alignment of the Current Feedback board is critical. Verify that the connector pins on the Current Feedback board are correctly aligned with their corresponding connectors on the drive. Failure to observe this precaution can result in bodily injury.

Step 5.2 Reinstall the Current Feedback board. Carefully align the two sets of connector pins on the Current Feedback board with their matching connectors on the drive. Gently press the board into place. The board should go in easily. If you feel resistance, a pin might be bent or misaligned. Recheck alignment and retry installation.

Step 5.3 Inspect the Current Feedback board connector thoroughly for bent or misaligned pins.

Step 5.4 Align the keypad support bracket with the mounting holes in the drive heat sink. Fasten the bracket with the three M4 x 10 screws removed earlier.

Step 5.5 Align the Regulator board's 26-conductor ribbon cable connector with the Current Feedback board connector. Press it in until it locks into position.

Step 5.6 Connect the RMI wiring to the appropriate RMI terminals for your application. Route the wire through the left-most wire-routing hole at the bottom of the drive. Refer to section 3.9 for terminal identification.

Step 5.7 Reconnect any wiring that was removed from the Regulator board terminal strip. Refer to the terminal connections documented in step 3.1 or to the appropriate instruction manuals for the devices being used.

Step 5.8 NEMA 4X/12 drives only: Before installing the cover, check that the gaskets on the cover are flat and within the gasket channels.

Step 5.9 Reinstall the cover. Align all cover screws into the heat sink before tightening any of them.

To maintain the integrity of NEMA 4X/12 drives, sequentially tighten the cover screws to ensure even compression of the gaskets. Do not exceed 2.2 Nm (20 in-lb) of torque on these screws.

Step 5.10 Remove the lockout and tag. Apply power to the drive. SELF will be displayed while the drive performs power-up diagnostics.

This completes the hardware installation of the RMI board. Refer to chapter 4 for the required software parameter settings for your drive.

3.2 Installing the RMI Board in 7.5 to 10 HP @ 460VAC Drives



ATTENTION: Only qualified electrical personnel familiar with the construction and operation of this equipment and the hazards involved should install, adjust, operate, or service this equipment. Read and understand this manual and other applicable manuals in their entirety before proceeding. Failure to observe this precaution could result in severe bodily injury or loss of life.

ATTENTION: The drive is at line voltage when connected to incoming AC power. Disconnect, lock out, and tag all incoming power to the drive before performing the following procedure. Failure to observe this precaution could result in severe bodily injury or loss of life.

ATTENTION: DC bus capacitors retain hazardous voltages after input power has been disconnected. After disconnecting input power, wait five minutes for the DC bus capacitors to discharge and then check the voltage with a voltmeter to ensure the DC bus capacitors are discharged before touching any internal components. Failure to observe this precaution could result in severe bodily injury or loss of life.

ATTENTION: The drive contains printed circuit boards that are static-sensitive. An anti-static wrist band should be worn by any person who touches the drive's components, connectors, or wiring. Erratic machine operation and damage to, or destruction of, equipment can result if this procedure is not followed. Failure to observe this precaution could result in bodily injury.

Use this procedure to install the RMI board in the drives listed in table 3.3.

Table 3.3 – Model Numbers for 7.5 to 10 HP @ 460VAC Drives

GV3000	VTAC 7
7V41xx 7V42xx	7H41xx 7H42xx
10V41xx 10V42xx	10H41xx 10H42xx

If the drive is panel-mounted, this procedure will be easier to perform if the drive is removed from the panel.

Unless otherwise indicated, keep all hardware that is removed. You will need it for reassembly. This includes screws, lock washers, and rivets.

Important: Read and understand the warning labels on the outside of the drive before proceeding.

Step 1. Shut Down the Drive

Step 1.1 Disconnect, lock out, and tag all incoming power to the drive.

Step 1.2 Wait five minutes for the DC bus capacitors to discharge.

Step 1.3 Remove the cover by loosening the four cover screws.

Important: Read and understand the warning labels on the inside of the drive before proceeding.

Step 2. Verify That the DC Bus Capacitors are Discharged

Step 2.1 Use a voltmeter to verify that there is no voltage at the drive's AC input power terminals (R/L1, S/L2, T/L3).

Step 2.2 Ensure that the DC bus capacitors are discharged. To check DC bus potential:

- a. Stand on a non-conductive surface and wear insulated gloves.
- b. Use a voltmeter to measure the DC bus potential at the DC bus power terminals shown in figure 3.3.

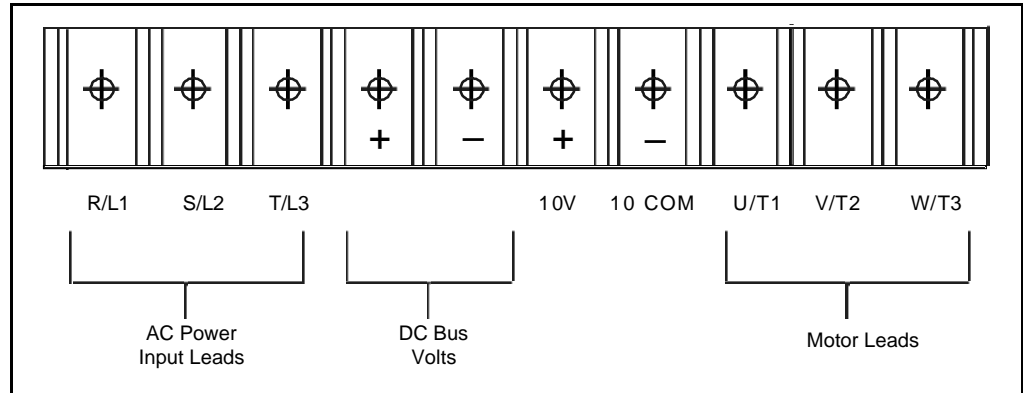

Figure 3.3 – DC Bus Voltage Terminals (7.5 to 10HP @ 460VAC)

Step 3. Remove the Keypad Bracket from the Drive

Step 3.1 Record connections to the Regulator board terminal strip if they must be disconnected to remove the keypad bracket.

Step 3.2 Loosen the thumb screw on the left side of the keypad bracket. Hold the bracket on the left and lift the bracket up and to the left to separate it from the keypad support bracket.

Important: The keypad support bracket is connected to the drive by wiring. Do not lift the bracket out completely, because this can damage or pull out wiring. Tie up or support the bracket to prevent damage to the wiring.

Step 3.3 Spread the retaining clips on the 26-conductor Regulator board ribbon cable connector to disconnect it from the Current Feedback board. The Current Feedback board is located on the right below the keypad.

Step 4. Install the RMI Board in the Keypad Bracket



ATTENTION: The RMI board contains components that are static-sensitive. An anti-static wrist band should be worn by any person who touches the board's components, connectors, or wiring. Failure to observe this precaution could result in damage to the RMI board.

Refer to figure 3.4 for component locations.

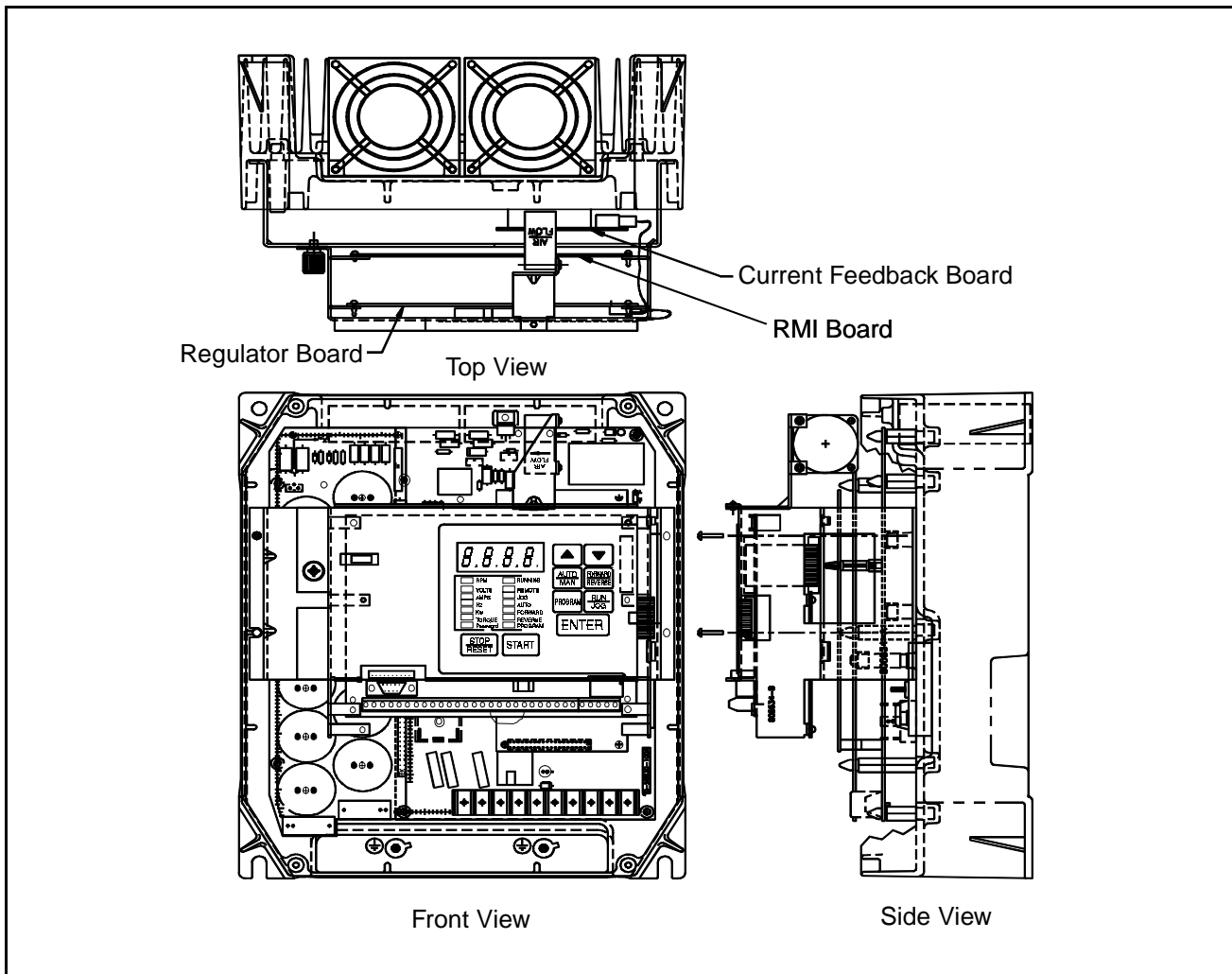

Figure 3.4 – RMI Board Location in 7.5 to 10HP Drives

- Step 4.1 Remove the RMI board from its anti-static wrapper and verify that the jumper settings are correct. Refer to figure 2.1 for jumper locations and appendix A for jumper settings.
- Step 4.2 Align the key on the Regulator board's 34-conductor ribbon cable connector with the slot in the RMI board's connector. Press the ribbon cable connector in until it locks into position.
- Step 4.3 Route the 26-conductor ribbon cable for the Current Feedback board out of the side of the keypad bracket.

Step 4.4 Align the RMI board on the four mounting tabs on the keypad bracket. Make sure that the ribbon cable is not pinched between the keypad bracket and the RMI board.

Step 4.5 Fasten the RMI board to the right side of the keypad bracket using the two metal M3 screws and lock washers for proper grounding. Fasten the left side using the two 6-32 screws and lock washers for proper grounding.

Important: You must use the lock washers to properly ground the RMI board. Improper grounding of the RMI board can result in erratic operation of the drive.

Step 4.6 Reconnect the keypad bracket to the keypad support bracket by inserting the mounting tabs into the slots in the keypad support bracket and tightening the thumb screw.

Step 4.7 Align the Regulator board's 26-conductor ribbon cable connector with the Current Feedback board connector. Press it in until it locks into position.

Step 5. Connect RMI Wiring and Reassemble the Drive

Step 5.1 Connect the RMI wiring to the appropriate RMI terminals for your application. Route the wire through the left-most wire-routing hole at the bottom of the drive. Refer to section 3.9 for terminal identification.

Step 5.2 Reconnect any wiring that was removed from the Regulator board terminal strip. Refer to the terminal connections documented in step 3.1 or to the appropriate instruction manuals for the devices being used.

Step 5.3 NEMA 4X/12 drives only: Before installing the cover, check that the gaskets on the cover are flat and within the gasket channels.

Step 5.4 Reinstall the cover. Align all cover screws into the heat sink before tightening any of them.

To maintain the integrity of NEMA 4X/12 drives, sequentially tighten the cover screws to ensure even compression of the gaskets. Do not exceed 2.2 Nm (20 in-lb) of torque on these screws.

Step 5.5 Remove the lockout and tag. Apply power to the drive. SELF will be displayed while the drive performs power-up diagnostics.

This completes the hardware installation of the RMI board. Refer to chapter 4 for the required software parameter settings for your drive.

3.3 Installing the RMI Board in 1 to 20HP @ 230VAC Drives



ATTENTION: Only qualified electrical personnel familiar with the construction and operation of this equipment and the hazards involved should install, adjust, operate, or service this equipment. Read and understand this manual and other applicable manuals in their entirety before proceeding. Failure to observe this precaution could result in severe bodily injury or loss of life.

ATTENTION: The drive is at line voltage when connected to incoming AC power. Disconnect, lock out, and tag all incoming power to the drive before performing the following procedure. Failure to observe this precaution could result in severe bodily injury or loss of life.

ATTENTION: DC bus capacitors retain hazardous voltages after input power has been disconnected. After disconnecting input power, wait five minutes for the DC bus capacitors to discharge and then check the voltage with a voltmeter to ensure the DC bus capacitors are discharged before touching any internal components. Failure to observe this precaution could result in severe bodily injury or loss of life.

ATTENTION: The drive contains printed circuit boards that are static-sensitive. An anti-static wrist band should be worn by any person who touches the drive's components, connectors, or wiring. Erratic machine operation and damage to, or destruction of, equipment can result if this procedure is not followed. Failure to observe this precaution could result in bodily injury.

Use this procedure to install the RMI board in the drives listed in table 3.4.

Table 3.4 – Model Numbers for 1 to 20HP @ 230VAC Drives

GV3000/SE Drives	VTAC 7 Drives
1V21xx 1V24xx	1H21xx 1H22xx
2V21xx 2V24xx	2H21xx 2H22xx
3V21xx 3V24xx	3H21xx 3H22xx
5V21xx 5V24xx	5H21xx 5H22xx
7V21xx 7V22xx	7H21xx 7H22xx
10V21xx 10V22xx	10H21xx 10H22xx
15V21xx 15V22xx	15H21xx 15H22xx
20V21xx 20V22xx	20H21xx 20H22xx

If the drive is panel-mounted, this procedure will be easier to perform if the drive is removed from the panel.

Unless otherwise indicated, keep all hardware that is removed. You will need it for reassembly. This includes screws, lock washers, and rivets.

Important: Read and understand the warning labels on the outside of the drive before proceeding.

Step 1. Shut Down the Drive

Step 1.1 Disconnect, lock out, and tag all incoming power to the drive.

Step 1.2 Wait five minutes for the DC bus capacitors to discharge.

Step 1.3 Remove the cover by loosening the four cover screws.

Important: Read and understand the warning labels on the inside of the drive before proceeding.

Step 2. Verify That the DC Bus Capacitors are Discharged

Step 2.1 Use a voltmeter to verify that there is no voltage at the drive's AC input power terminals (R/L1, S/L2, T/L3).

Step 2.2 Ensure that the DC bus capacitors are discharged. To check DC bus potential:

- a. Stand on a non-conductive surface and wear insulated gloves.
- b. Use a voltmeter to measure the DC bus potential at the DC bus power terminals shown in figure 3.5.

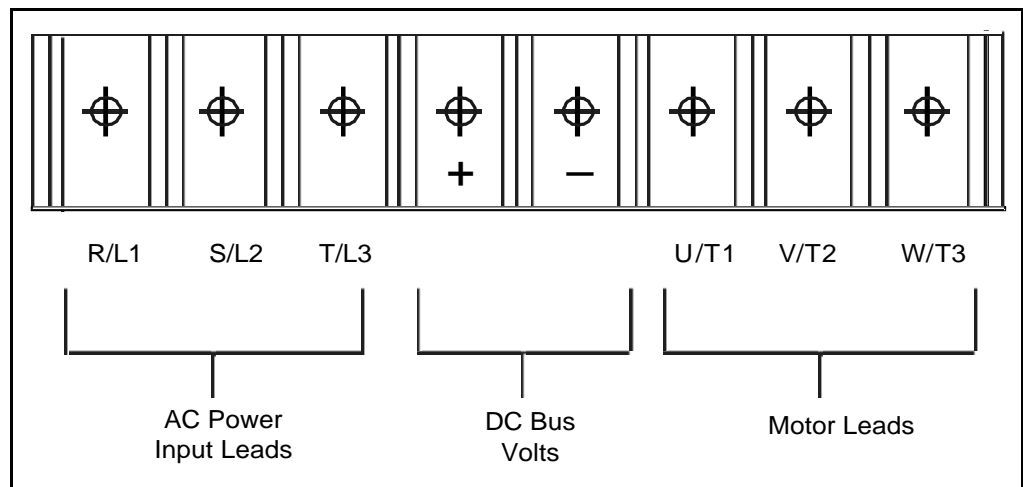

Figure 3.5 – DC Bus Voltage Terminals (1 to 20HP @ 230VAC)

Step 3. Remove the Keypad Bracket from the Drive

- Step 3.1 Record connections to the Regulator board terminal strip if they must be disconnected to remove the keypad bracket.
- Step 3.2 Use a magnetic screwdriver to remove the M4 x 10 screws that fasten the bottom of the keypad support bracket to the drive.
- Step 3.3 Spread the retaining clips on the Regulator board ribbon cable (on the right side) to disconnect it from the Base Board.
- Step 3.4 Remove the keypad bracket. Place it with the keypad down on a flat surface. If you cannot lay it flat, tie it up to prevent damage to wiring.

Step 4. Install the RMI Board in the Keypad Bracket

Refer to figure 3.6 for component locations.

- Step 4.1 Remove the RMI board from its anti-static wrapper and verify that the jumper settings are correct. Refer to figure 2.1 for jumper locations and appendix A for jumper settings.
- Step 4.2 Align the key on the Regulator board's 34-conductor ribbon cable connector with the slot in the RMI board's connector. Press the ribbon cable connector in until it locks into position.
- Step 4.3 Route the other ribbon cable out of the side of the keypad bracket.
- Step 4.4 Align the RMI board on the four mounting tabs on the keypad bracket. Make sure that the ribbon cable is not pinched between the keypad bracket and the RMI board.
- Step 4.5 Fasten the RMI board to the right side of the keypad bracket using the two metal M3 screws and lock washers for proper grounding. Fasten the left side using the two 6-32 screws and lock washers for proper grounding.

Important: You must use the lock washers to properly ground the RMI board. Improper grounding of the RMI board can result in erratic operation of the drive.

Step 5. Reinstall the Keypad Bracket in the Drive

- Step 5.1 Place the keypad support bracket back into position. Use a magnetic screwdriver to fasten it to the drive with the screws removed in step 3.2.
- Step 5.2 Realign the 26-conductor ribbon cable connector with the connector inside the slot in the keypad support bracket. Carefully press the ribbon cable connector in until the retaining clips lock into place.
- Step 5.3 Connect the RMI wiring to the appropriate RMI terminals for your application. Route the wire through the left-most wire-routing hole at the bottom of the drive. Refer to section 3.9 for terminal identification.
- Step 5.4 Reconnect any wiring that was removed from the Regulator board terminal strip. Refer to the terminal connections documented in step 3.1 or to the appropriate instruction manuals for the devices being used.
- Step 5.5 NEMA 4X/12 drives only: Before installing the cover, check that the gaskets on the cover are flat and within the gasket channels.

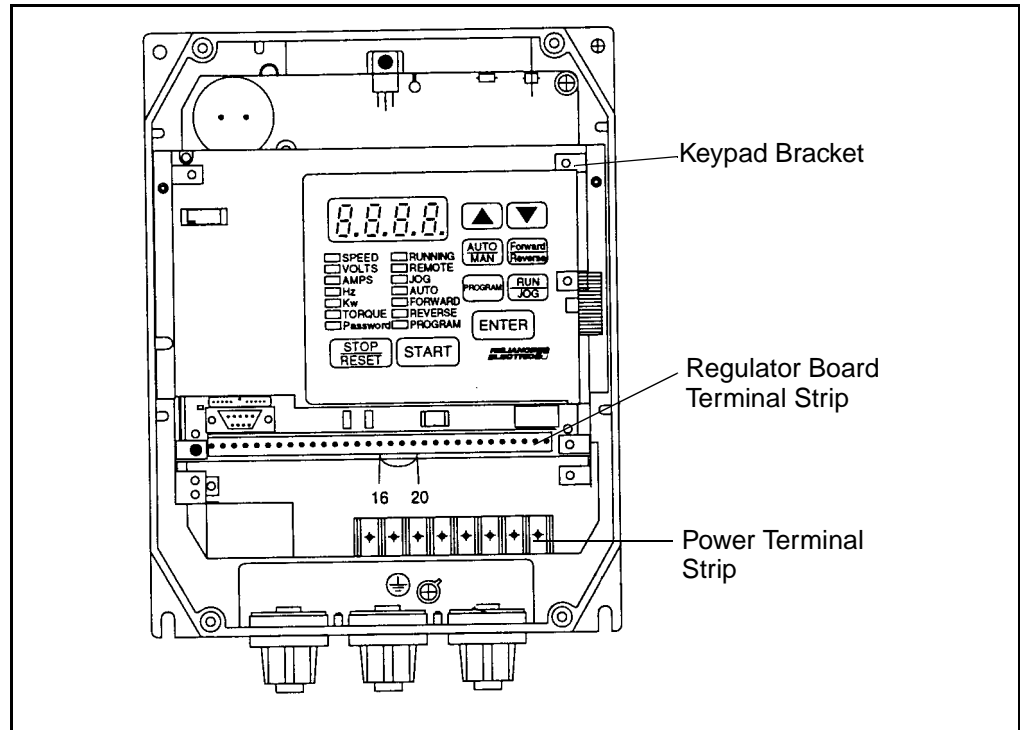

Figure 3.6 – 1 to 20HP @ 230 V GV3000/SE Drive

Step 5.6 Reinstall the cover. Align all cover screws into the heat sink before tightening any of them.

To maintain the integrity of NEMA 4X/12 drives, sequentially tighten the cover screws to ensure even compression of the gaskets. Do not exceed 2.2 Nm (20 in-lb) of torque on these screws.

Step 5.7 Remove the lockout and tag. Apply power to the drive. SELF will be displayed while the drive performs power-up diagnostics.

This completes the hardware installation of the RMI board. Refer to chapter 4 for the required software parameter settings for your drive.

3.4 Installing the RMI Board in 30 to 100HP @ 230VAC and 75 to 200 @ 460VAC Drives



ATTENTION: Only qualified electrical personnel familiar with the construction and operation of this equipment and the hazards involved should install, adjust, operate, or service this equipment. Read and understand this manual and other applicable manuals in their entirety before proceeding. Failure to observe this precaution could result in severe bodily injury or loss of life.

ATTENTION: The drive is at line voltage when connected to incoming AC power. Disconnect, lock out, and tag all incoming power to the drive before performing the following procedure. Failure to observe this precaution could result in severe bodily injury or loss of life.

ATTENTION: DC bus capacitors retain hazardous voltages after input power has been disconnected. After disconnecting input power, wait five minutes for the DC bus capacitors to discharge and then check the voltage with a voltmeter to ensure the DC bus capacitors are discharged before touching any internal components. Failure to observe this precaution could result in severe bodily injury or loss of life.

ATTENTION: The drive contains printed circuit boards that are static-sensitive. An anti-static wrist band should be worn by any person who touches the drive's components, connectors, or wiring. Erratic machine operation and damage to, or destruction of, equipment can result if this procedure is not followed. Failure to observe this precaution could result in bodily injury.

Use this procedure to install the RMI board in the drives listed in table 3.5.

Table 3.5 – Model Numbers for 30 to 100 HP @ 230 VAC and 75 to 200HP @ 460VAC Drives

30 to 100HP @ 230VAC		75 to 200HP @ 460VAC	
GV3000/SE Drives	VTAC 7 Drives	GV3000/SE Drives	VTAC 7 Drives
30V20xx	30W21xx	75V40xx	75H41xx 75W41xx
40V20xx	40W21xx	100V40xx	100H41xx 100W41xx
50V20xx	50W21xx	125V40xx	125H41xx 125W41xx
60V20xx	60W21xx	150V40xx	150H41xx 150W41xx
75V20xx	75W21xx	200V40xx	200W41xx
100V20xx	100H21xx		

Unless otherwise indicated, keep all hardware that is removed. You will need it for reassembly. This includes screws, lock washers, and rivets.

Important: Read and understand the warning labels on the outside of the drive before proceeding.

Step 1. Shut Down the Drive

Step 1.1 Disconnect, lock out, and tag all incoming power to the drive.

Step 1.2 Wait five minutes for the DC bus capacitors to discharge.

Step 1.3 VTAC 7 drives: Open the drive's outer cabinet door.

Important: Read and understand the warning labels on the inside of the drive before proceeding.

Step 2. Verify That the DC Bus Capacitors are Discharged

Step 2.1 Use a voltmeter to verify that there is no voltage at the drive's AC input power terminals (R/L1, S/L2, T/L3 or U/T1, V/T2, W/T3).

Step 2.2 Ensure that the DC bus capacitors are discharged. To check DC bus potential:

- a. Stand on a non-conductive surface and wear insulated gloves.
- b. Use a voltmeter to measure the DC bus potential at the DC bus power terminals shown in figure 3.7.

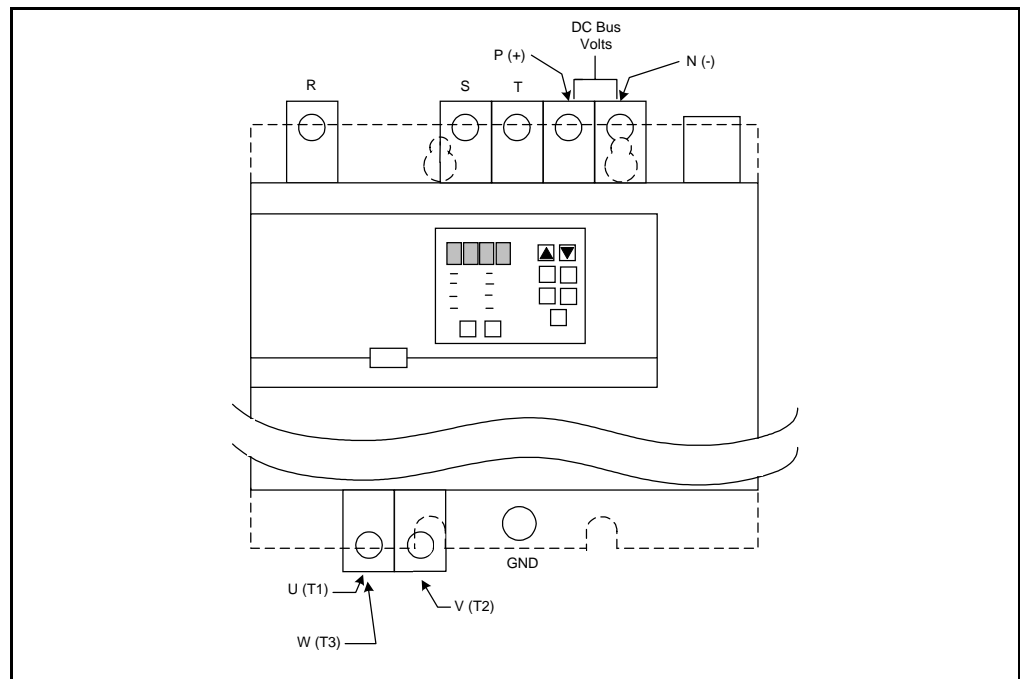

Figure 3.7 – DC Bus Voltage Terminals (30 to 100HP @ 230VAC and 75 to 200HP @ 460VAC)

Step 3. Remove the Keypad Bracket from the Drive

Step 3.1 VTAC 7 drives: Remove the Power Module from the drive cabinet.

Step 3.2 If the drive has:

- A Regulator board and terminal cover: Remove the three M4 screws from the cover plate over the Regulator board. Remove the cover. See figure 3.8.
- A terminal cover only: If you have this type of drive, this procedure is easier to perform if you lay the drive on its side. Remove the side cover from the drive. Use a long magnetized screwdriver to unfasten the four screws that hold the keypad bracket in.

Step 3.3 Remove the terminal cover, which is below the keypad and fastened with two M4 screws. See figure 3.8.

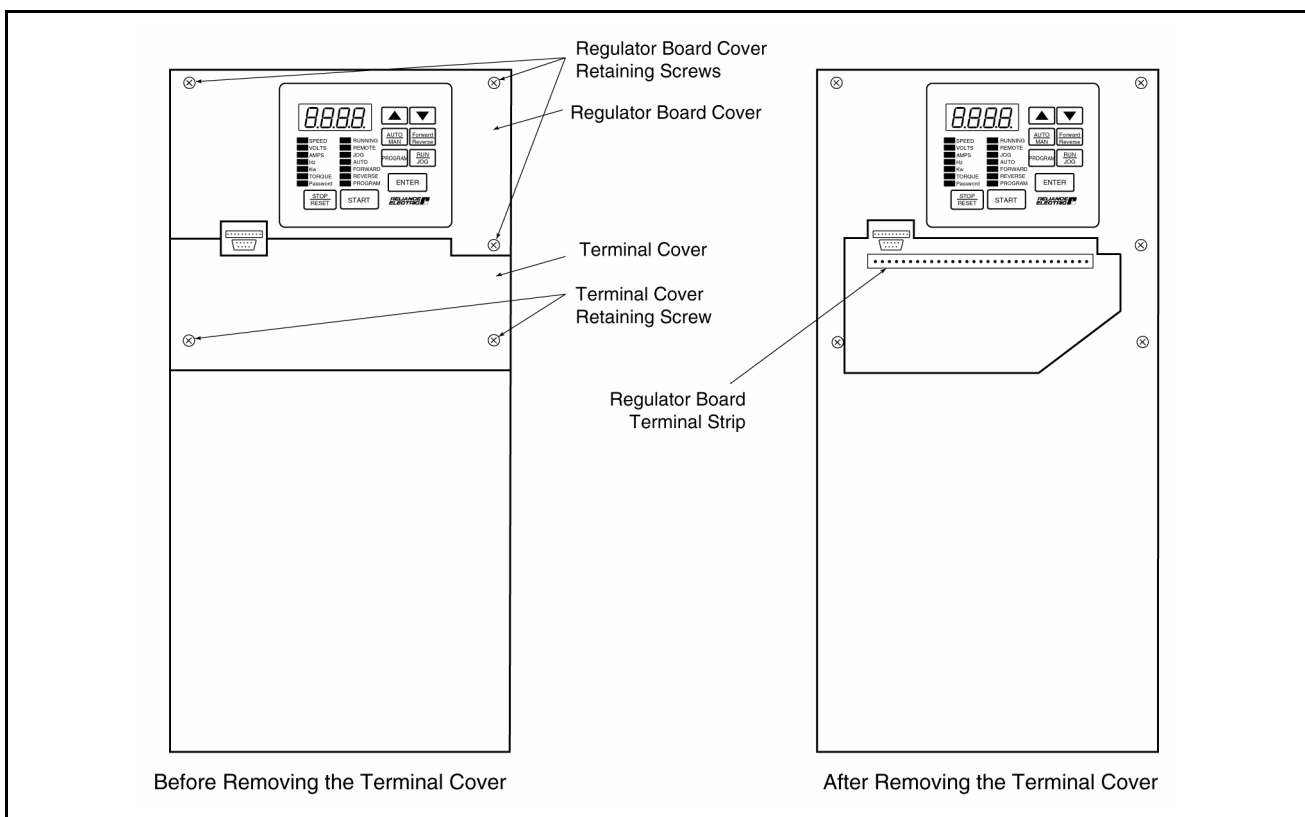

Figure 3.8 – Location of Terminal Cover and Regulator Board Cover in 30 to 100HP @ 230VAC and 75 to 200HP @ 460VAC Drives

- Step 3.4 Record connections to the Regulator board terminal strip if they must be disconnected to remove the keypad bracket.
- Step 3.5 VTAC 7 drives: Remove the anodized inner cover by removing the two M3 roundhead screws.
- Step 3.6 Pull the keypad assembly partly out of the drive. Spread the retaining clips on the Regulator board ribbon cable (on the right side) to disconnect it from the Base Board. See figure 3.9.
- Step 3.7 Remove the keypad bracket. Place it with the keypad down on a flat surface. If you cannot lay it flat, tie it up to prevent damage to wiring.

Step 4. Install the RMI Board in the Keypad Bracket



ATTENTION: The RMI board contains components that are static-sensitive. An anti-static wrist band should be worn by any person who touches the board's components, connectors, or wiring. Failure to observe this precaution could result in damage to the RMI board.

Refer to figures 3.8 and 3.9 for component locations.

- Step 4.1 Remove the RMI board from its anti-static wrapper and verify that the jumper settings are correct. Refer to figure 2.1 for jumper locations and appendix A for jumper settings.
- Step 4.2 Align the key on the Regulator board's 34-conductor ribbon cable connector with the slot in the RMI board's connector. Press the ribbon cable connector in until it locks into position.
- Step 4.3 Route the other ribbon cable out of the side of the keypad support bracket.
- Step 4.4 Align the RMI board on the four mounting tabs on the keypad bracket. Make sure that the ribbon cable is not pinched between the keypad bracket and the RMI board.
- Step 4.5 Fasten the RMI board to the right side of the keypad bracket using the two metal M3 screws and lock washers for proper grounding. Fasten the left side using the two 6-32 screws and lock washers for proper grounding.

Important: You must use the lock washers to properly ground the RMI board. Improper grounding of the RMI board can result in erratic operation of the drive.

Step 5. Reinstall the Keypad Bracket in the Drive

- Step 5.1 Align the Regulator board ribbon cable connector with the connector to the Base board. Carefully press the ribbon cable connector in until the retaining clips lock into place.
- Step 5.2 Place the keypad bracket back into position.
- Step 5.3 VTAC 7 drives: Reattach the anodized inner cover using the two screws removed in step 3.5.
- Step 5.4 If the drive has:
 - A Regulator board cover and a terminal cover: Replace the Regulator board cover. Fasten it using the three M4 screws removed in earlier.
 - Only a terminal cover: Use a long magnetized screwdriver to fasten the four screws that hold the keypad bracket. Replace the side cover.
- Step 5.5 Connect the RMI wiring to the appropriate RMI terminals for your application. Route the wiring through the rectangular hole at the left-front corner of the drive bottom. For terminal identification, see section 3.9.
- Step 5.6 Reconnect any wiring that was removed from the Regulator board terminal strip. Refer to the terminal connections documented in step 3.4 or to the appropriate instruction manuals for the devices being used.

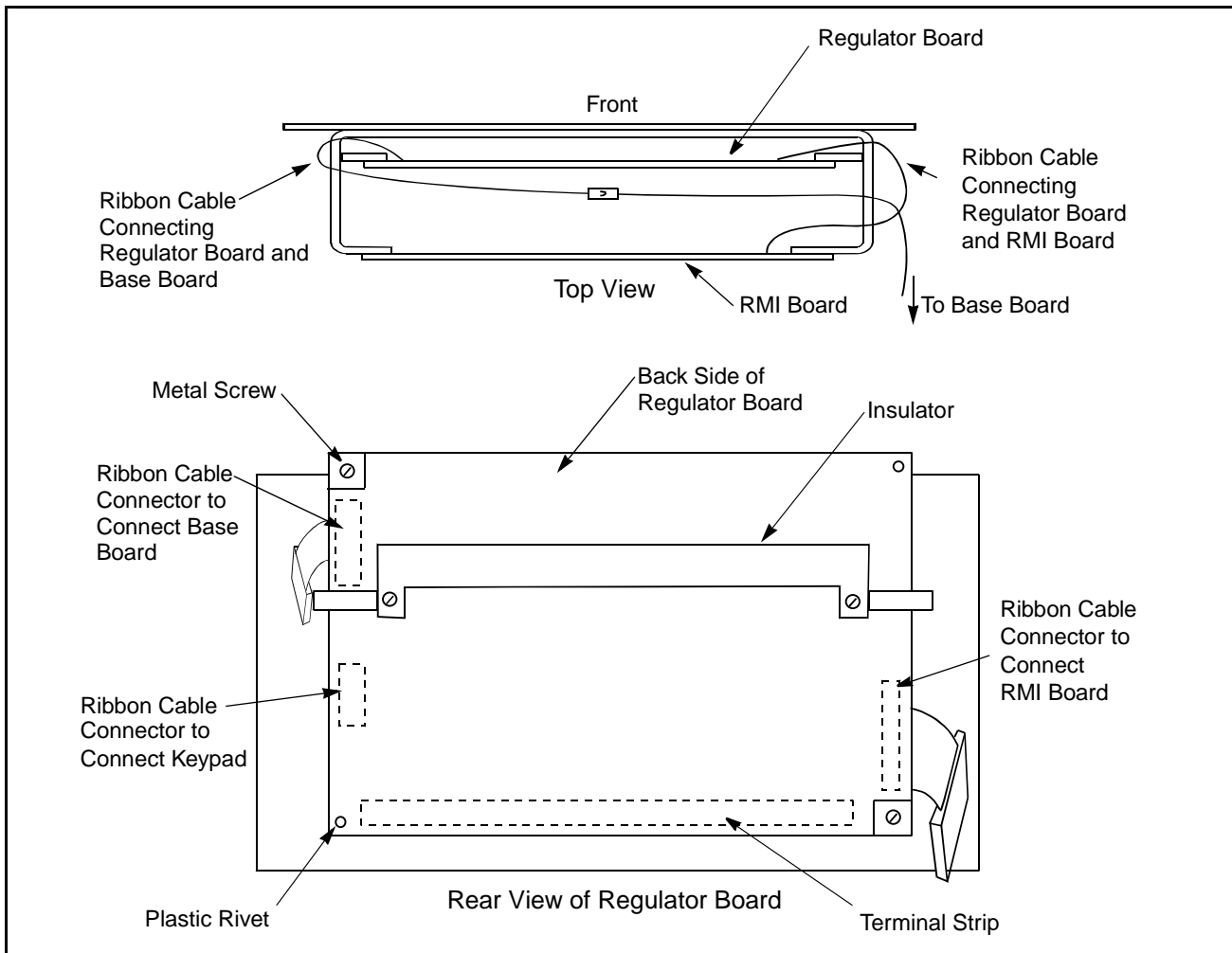

Figure 3.9 – Regulator Board's Connection to RMI Board, Keypad, and Base Board

Step 5.7 Replace the terminal cover (below the keypad). Fasten it using the M4 screws removed earlier.

Step 5.8 VTAC 7 drives: Reinstall the Power Module in the drive cabinet.

Step 5.9 VTAC 7 drives: Close the outer cabinet door.

Step 5.10 Remove the lockout and tag. Apply power to the drive. SELF will be displayed while the drive performs power-up diagnostics.

This completes the hardware installation of the RMI board. Refer to chapter 4 for the required software parameter settings for your drive.

3.5 Installing the RMI Board in 15 to 25HP and 25 to 60HP @ 460VAC Drives



ATTENTION: Only qualified electrical personnel familiar with the construction and operation of this equipment and the hazards involved should install, adjust, operate, or service this equipment. Read and understand this manual and other applicable manuals in their entirety before proceeding. Failure to observe this precaution could result in severe bodily injury or loss of life.

ATTENTION: The drive is at line voltage when connected to incoming AC power. Disconnect, lock out, and tag all incoming power to the drive before performing the following procedure. Failure to observe this precaution could result in severe bodily injury or loss of life.

ATTENTION: DC bus capacitors retain hazardous voltages after input power has been disconnected. After disconnecting input power, wait five minutes for the DC bus capacitors to discharge and then check the voltage with a voltmeter to ensure the DC bus capacitors are discharged before touching any internal components. Failure to observe this precaution could result in severe bodily injury or loss of life.

ATTENTION: The drive contains printed circuit boards that are static-sensitive. An anti-static wrist band should be worn by any person who touches the drive's components, connectors, or wiring. Erratic machine operation and damage to, or destruction of, equipment can result if this procedure is not followed. Failure to observe this precaution could result in bodily injury.

Use this procedure to install the RMI board in the drives listed in table 3.6.

Table 3.6 – Model Numbers for 15 to 25HP and 25 to 60HP @ 460VAC Drives

15 to 25 HP		25 to 60 HP	
GV3000	VTAC 7	GV3000	VTAC 7
15V41xx 15V42xx	15H41xx 15H42xx	25V41xx 25V42xx	25W21xx
20V41xx 20V42xx	20H41xx 20H42xx	30V41xx 30V42xx	30H41xx 30H42xx
25G41xx 25G42xx	25H41xx 25H42xx	40V41xx 40V42xx	40H41xx 40H42xx
		50V41xx 50V42xx	50H41xx 50H42xx
		60G41xx 60G42xx	60H41xx 60H42xx

Unless otherwise indicated, keep all hardware that is removed. You will need it for reassembly. This includes screws, lock washers, and rivets.

If the drive is panel-mounted, this procedure will be easier to perform if the drive is removed from the panel.

Important: Read and understand the warning labels on the outside of the drive before proceeding.

Step 1. Shut Down the Drive

Step 1.1 Disconnect, lock out, and tag all incoming power to the drive.

Step 1.2 Wait five minutes for the DC bus capacitors to discharge.

Step 1.3 Remove the cover by loosening the four cover screws.

Important: Read and understand the warning labels on the inside of the drive before proceeding.

Step 2. Verify That the DC Bus Capacitors are Discharged

Step 2.1 Use a voltmeter to verify that there is no voltage at the drive's AC input power terminals (R/L1, S/L2, T/L3).

Step 2.2 Ensure that the DC bus capacitors are discharged. To check DC bus potential:

- Stand on a non-conductive surface and wear insulated gloves.
- Use a voltmeter to measure the DC bus potential at the DC bus power terminals as shown in figures 3.10 (15 to 25HP @ 460V) and 3.11 (25 to 60HP @ 460V).

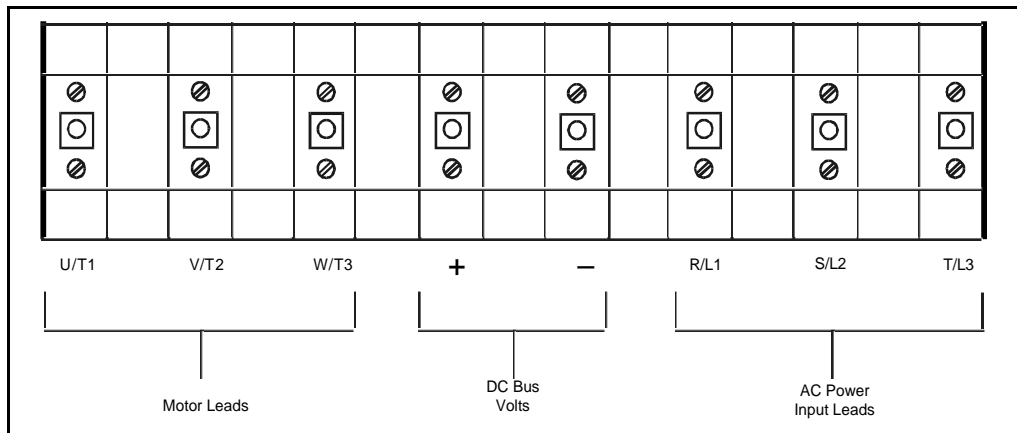

Figure 3.10 – DC Bus Voltage Terminals (15 to 25 HP @ 460VAC)

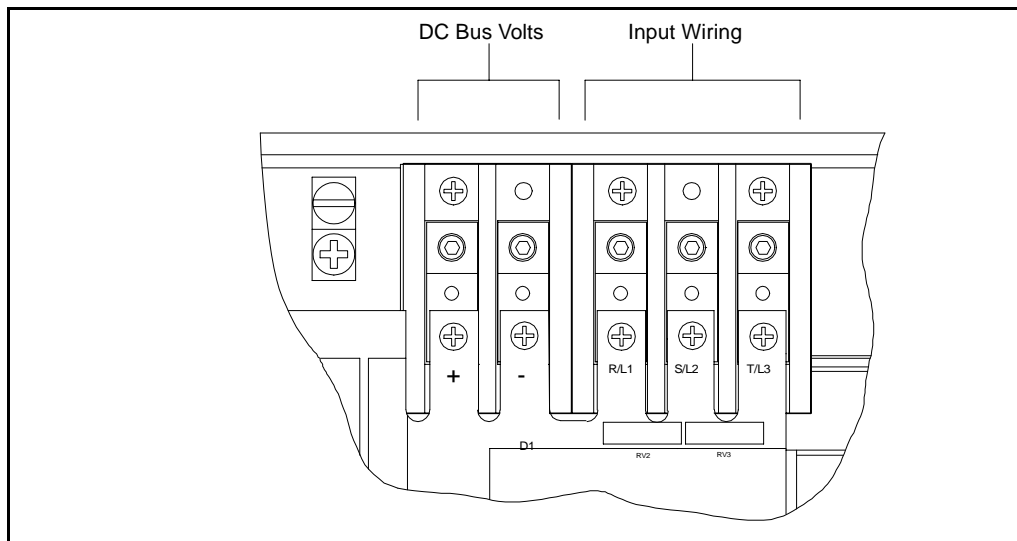

Figure 3.11 – DC Bus Voltage Terminals (25 to 60 HP @ 460VAC)

Step 3. Remove the Keypad Bracket from the Drive

See figure 3.12 (15 to 25HP @ 460VAC) or 3.13 (25 to 60HP @ 460VAC) for part locations.

Step 3.1 Record connections to the Regulator board terminal strip if they must be disconnected to remove the keypad bracket.

Step 3.2 Loosen the thumb screw on the left side of the keypad bracket. Hold the bracket on the left and lift the bracket up and to the left to separate it from the keypad support bracket.

Important: The keypad support bracket is connected to the drive by wiring. Do not lift the bracket out completely, because this can damage or pull out wiring. Tie up or support the bracket to prevent damage to the wiring.

Step 3.3 Disconnect the 26-conductor Regulator board ribbon cable from the Power Supply board (located on the right side below the keypad). You can see the connector through the slot on the keypad support bracket. Use a small screwdriver inserted through the slot to spread the retaining clips on the connector to release it.

Step 4. Install the RMI Board in the Keypad Bracket



ATTENTION: The RMI board contains components that are static-sensitive. An anti-static wrist band should be worn by any person who touches the board's components, connectors, or wiring. Failure to observe this precaution could result in damage to the RMI board.

Step 4.4 Remove the RMI board from its anti-static wrapper and verify that the jumper settings are correct. Refer to figure 2.1 for jumper locations and appendix A for jumper settings.

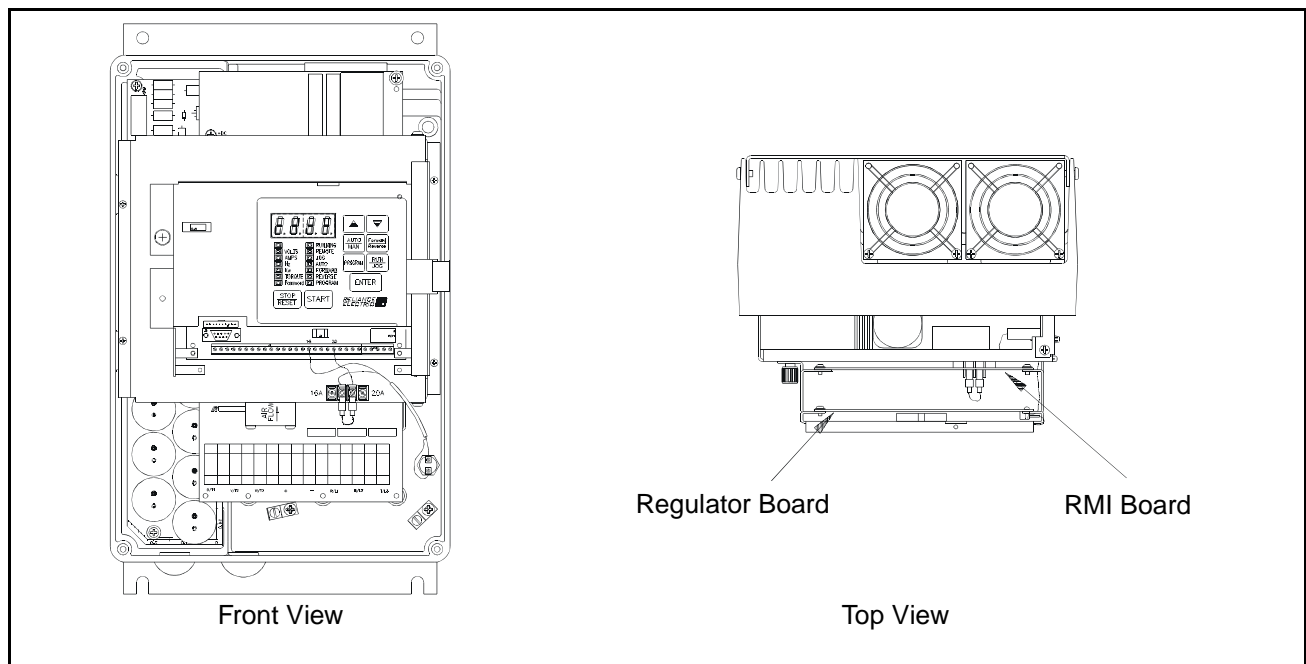

Figure 3.12 – RMI Board Location in 15 to 25 HP @ 460VAC Drives

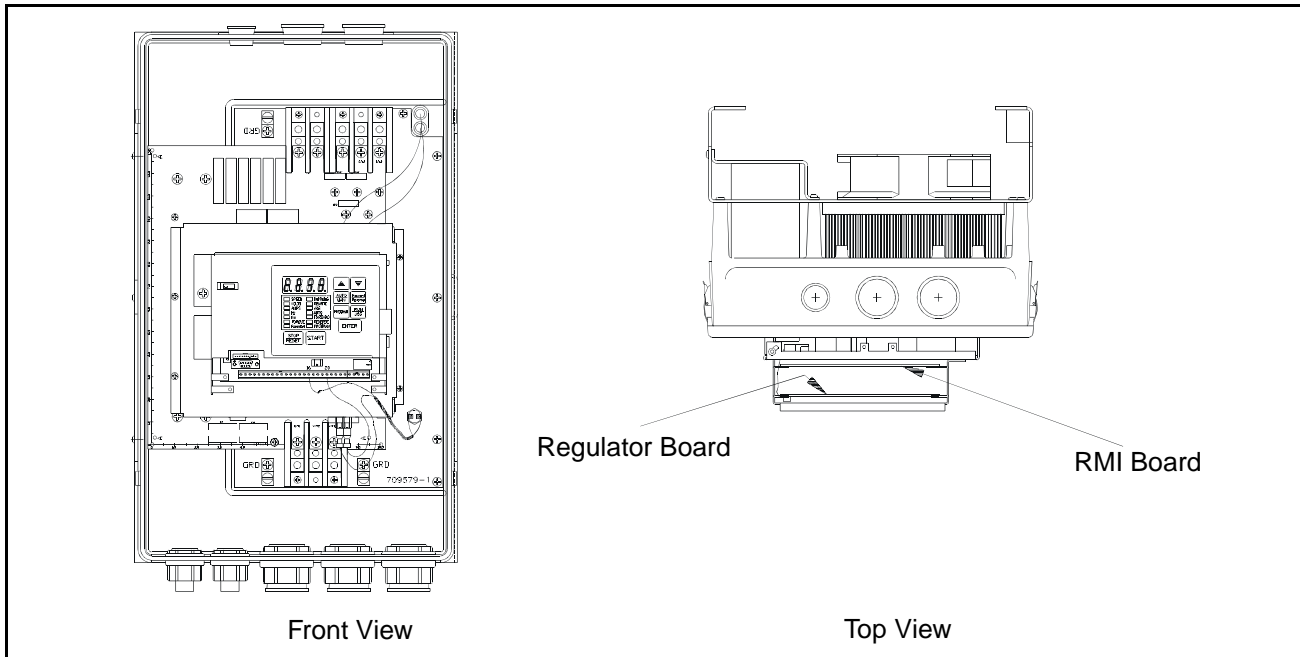

Figure 3.13 – RMI Board Location in 25 to 60 HP @ 460VAC Drives

Step 4.5 Align the key on the Regulator board's 34-conductor ribbon cable connector with the slot in the RMI board's connector. Press the ribbon cable connector in until it locks into position.

Step 4.6 Align the RMI board on the four mounting tabs on the keypad bracket. Make sure that the ribbon cable is not pinched between the keypad bracket and the RMI board.

Step 4.7 Fasten the RMI board to the right side of the keypad bracket using the two metal M3 screws and lock washers for proper grounding. Fasten the left side using the two 6-32 screws and lock washers for proper grounding.

Important: You must use the lock washers to properly ground the RMI board. Improper grounding of the RMI board can result in erratic operation of the drive.

Step 4.8 Realign the 26-conductor ribbon cable connector with the Power Supply board connector inside the slot in the keypad support bracket. Carefully press the ribbon cable connector in until the retaining clips lock it into place.

Step 5. Reinstall the Keypad Bracket in the Drive

Step 5.1 Reconnect the keypad bracket to the keypad support bracket by inserting the mounting tabs into the slots in the keypad support bracket and tightening the thumb screw.

Step 5.2 Connect the RMI wiring to the appropriate RMI terminals for your application. Route the wire through the left-most wire-routing hole at the bottom of the drive. Refer to section 3.9 for terminal identification.

Step 5.3 Reconnect any wiring that was removed from the Regulator board terminal strip. Refer to the terminal connections documented in step 3.1 or to the appropriate instruction manuals for the devices being used.

Step 5.4 NEMA 4X/12 drives only: Before installing the cover, check that the gaskets on the cover are flat and within the gasket channels.

Step 5.5 Reinstall the cover. Align all cover screws into the heat sink before tightening any of them.

To maintain the integrity of NEMA 4X/12 drives, sequentially tighten the cover screws to ensure even compression of the gaskets. Do not exceed 2.2 Nm (20 in-lb) of torque on these screws.

Step 5.6 Remove the lockout and tag. Apply power to the drive. SELF will be displayed while the drive performs power-up diagnostics.

This completes the hardware installation of the RMI board. Refer to chapter 4 for the required software parameter settings for your drive.

3.6 Installing the RMI Board in 50 to 100HP and 100 to 150HP @ 460VAC Drives (GV3000/SE Drives Only)



ATTENTION: Only qualified electrical personnel familiar with the construction and operation of this equipment and the hazards involved should install, adjust, operate, or service this equipment. Read and understand this manual and other applicable manuals in their entirety before proceeding. Failure to observe this precaution could result in severe bodily injury or loss of life.

ATTENTION: The drive is at line voltage when connected to incoming AC power. Disconnect, lock out, and tag all incoming power to the drive before performing the following procedure. Failure to observe this precaution could result in severe bodily injury or loss of life.

ATTENTION: DC bus capacitors retain hazardous voltages after input power has been disconnected. After disconnecting input power, wait five minutes for the DC bus capacitors to discharge and then check the voltage with a voltmeter to ensure the DC bus capacitors are discharged before touching any internal components. Failure to observe this precaution could result in severe bodily injury or loss of life.

ATTENTION: The drive contains printed circuit boards that are static-sensitive. An anti-static wrist band should be worn by any person who touches the drive's components, connectors, or wiring. Erratic machine operation and damage to, or destruction of, equipment can result if this procedure is not followed. Failure to observe this precaution could result in bodily injury.

Use this procedure to install the RMI board in the GV3000/SE drives with the model number 50R41xx, 50T41xx, 75R41xx, 75T41xx, or 125R41xx.

Unless otherwise indicated, keep all hardware that is removed. You will need it for reassembly. This includes screws, lock washers, and rivets.

Important: Read and understand the warning labels on the outside of the drive before proceeding.

Step 1. Shut Down the Drive

Step 1.1 Disconnect, lock out, and tag all incoming power to the drive.

Step 1.2 Wait five minutes for the DC bus capacitors to discharge.

Step 1.3 Remove the cover from the drive by removing the six cover screws.

Important: Read and understand the warning labels on the inside of the drive before proceeding.

Step 2. Verify That the DC Bus Capacitors are Discharged

- Step 2.1 Use a voltmeter to verify that there is no voltage at the drive's AC input power terminals (1L1, 1L2, 1L3).
- Step 2.2 Ensure that the DC bus capacitors are discharged. To check DC bus potential:
 - a. Stand on a non-conductive surface and wear insulated gloves.
 - b. 50 to 100 HP @ 460 V only: Use a voltmeter to measure the DC bus potential at the diode bridge. Refer to figure 3.14.
 - c. 100 to 150 HP @ 460 V only: Take care not to touch any conductive traces. Use a voltmeter to measure the DC bus potential at the bottom of the fuse holders on the Power Module Interface board on the back of the Regulator panel. Refer to figure 3.15.

Step 3. Remove the Keypad Bracket from the Drive

Refer to figure 3.14 (50 to 100 HP drives) or 3.15 (100 to 150 HP drives) as you perform this procedure.

- Step 3.1 Loosen the two screws from the top of the hinged panel (where the keypad bracket is mounted). Tilt the mounting panel forward out of the chassis.
- Step 3.2 Record connections to the Regulator board terminal strip if they must be disconnected to remove the keypad bracket.
- Step 3.3 Spread the retaining clips on the Regulator board's 60-conductor ribbon cable connector to disconnect it from the Power Module Interface board. This ribbon cable runs from the top of the Regulator board through a slot in the mounting panel to the Power board on the other side. Slip the ribbon cable out of the slot to free it from the mounting panel.
- Step 3.4 Use a magnetic screwdriver to remove the four screws and lock washers that fasten the keypad bracket to the hinged mounting panel. Hold the keypad bracket as you remove the screws.

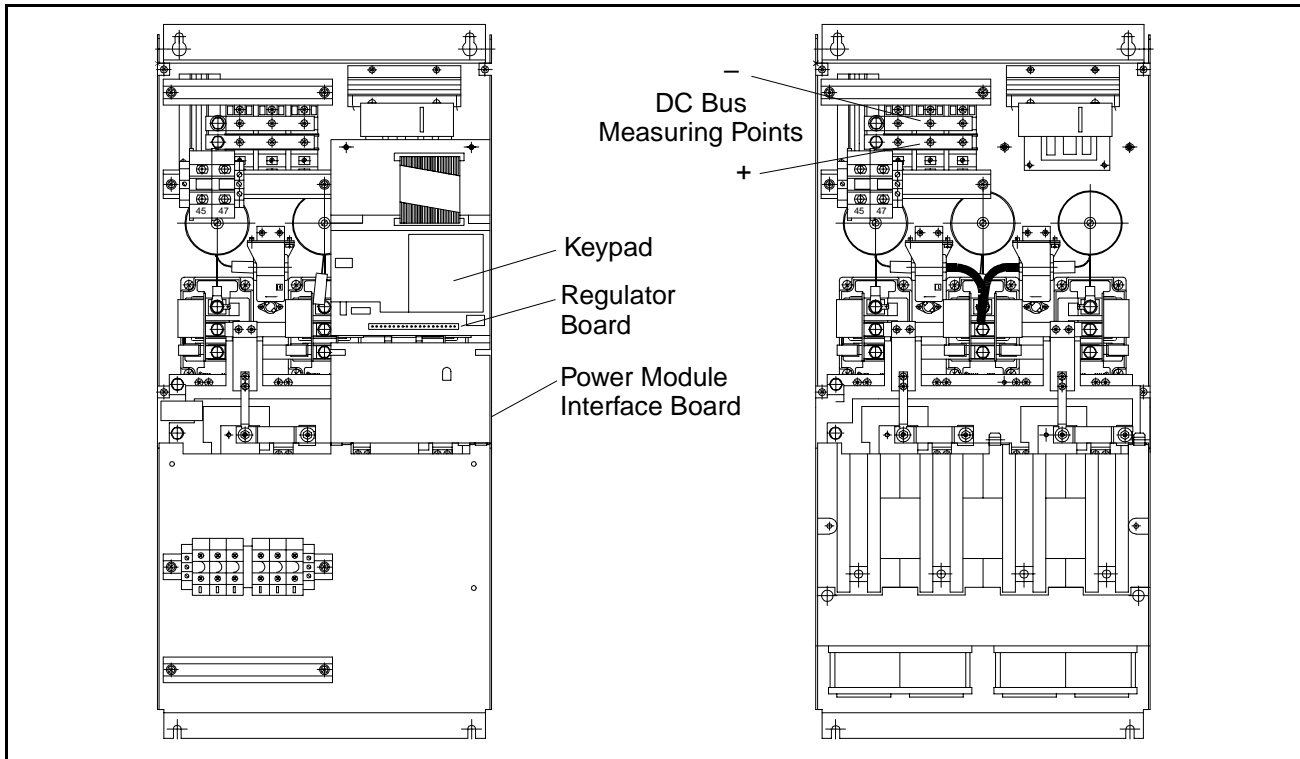

Figure 3.14 – Drive Components and Locations (50 to 100HP @ 460VAC)

Step 4. Install the RMI Board in the Keypad Bracket



ATTENTION: The RMI board contains components that are static-sensitive. An anti-static wrist band should be worn by any person who touches the board's components, connectors, or wiring. Failure to observe this precaution could result in damage to the RMI board.

- Step 4.1 Remove the RMI board from its anti-static wrapper and verify that the jumper settings are correct. Refer to figure 2.1 for jumper locations and appendix A for jumper settings.
- Step 4.2 Align the key on the Regulator board's 34-conductor ribbon cable connector with the slot in the RMI board's connector. Press the ribbon cable connector in until it locks into position.
- Step 4.3 Align the RMI board on the four mounting tabs on the keypad bracket. Make sure that the ribbon cable is not pinched between the keypad bracket and the RMI board.
- Step 4.4 Fasten the RMI board to the right side of the keypad bracket using the two metal M3 screws and lock washers for proper grounding. Fasten the left side using the two 6-32 screws and lock washers for proper grounding.

Important: You must use the lock washers to properly ground the RMI board. Improper grounding of the RMI board can result in erratic operation of the drive.

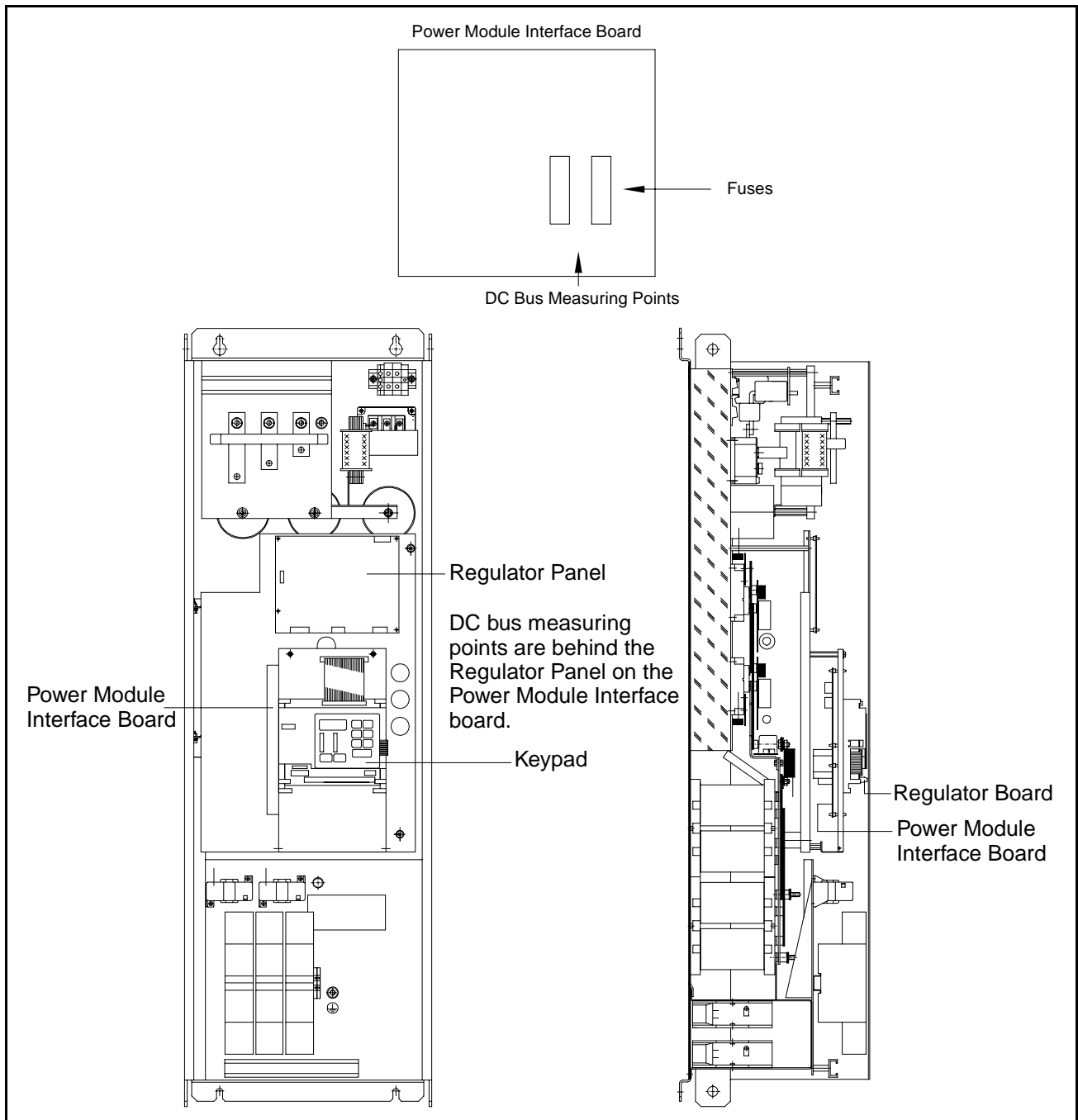

Figure 3.15 – Drive Components and Locations in 100 to 150HP @ 460VAC Drives

Step 5. Reinstall the Keypad Bracket in the Drive

Step 5.1 Reconnect the keypad bracket to the hinged mounting panel using the four screws and lock washers removed earlier.

Step 5.2 100 to 150 HP drives only: Remove the tie that was fastened to the Power Module Interface board earlier.

- Step 5.3 100 to 150 HP drives only: Align the Power Module Interface board on the eight plastic standoffs on the back of the mounting panel. Carefully press it into place. Make sure that good contact has been made with the two grounding standoffs.
- Step 5.4 Route the Regulator board's 60-conductor ribbon cable through the slot in the hinged mounting panel to the connector on the Power Module Interface board. Align the two connectors. Place your thumb beneath the Power Module Interface board for support and carefully press the ribbon cable connector in until it locks into position.
- Step 5.5 Swing the hinged mounting panel back into position. Make sure no wires or cables are pinched by the panel.
- Step 5.6 Refasten the two screws at the top of the panel.
- Step 5.7 Connect the RMI wiring to the appropriate RMI terminals for your application. Refer to section 3.9 for terminal identification. Route the wiring through the right-most wire-routing hole at the bottom of the drive, away from the AC lines.
- Step 5.8 Reconnect any wiring that was removed from the Regulator board terminal strip. Refer to the terminal connections documented in step 3.2 or to the appropriate instruction manuals for the devices being used.
- Step 5.9 Replace the mounting panel and fasten with two screws at the top of the hinged panel (where the keypad bracket is mounted).
- Step 5.10 NEMA 4X/12 drives only: Before installing the cover, check that the gaskets on the cover are flat and within the gasket channels.
- Step 5.11 Reinstall the cover with the six screws removed in step 1.3. Make sure no wiring is pinched by the cover.
- To maintain the integrity of NEMA 4X/12 drives, sequentially tighten the cover mounting screws to ensure even compression of the gaskets. Do not exceed 2.2 Nm (20 in-lb) of torque on these screws.
- Step 5.12 Remove the lockout and tag. Apply power to the drive. SELF will be displayed while the drive performs power-up diagnostics.

This completes the hardware installation of the RMI board. Refer to chapter 4 for the required software parameter settings for your drive.

3.7 Installing the RMI Board in 200 to 400 HP @ 460VAC Drives



ATTENTION: Only qualified electrical personnel familiar with the construction and operation of this equipment and the hazards involved should install, adjust, operate, or service this equipment. Read and understand this manual and other applicable manuals in their entirety before proceeding. Failure to observe this precaution could result in severe bodily injury or loss of life.

ATTENTION: The drive is at line voltage when connected to incoming AC power. Disconnect, lock out, and tag all incoming power to the drive before performing the following procedure. Failure to observe this precaution could result in severe bodily injury or loss of life.

ATTENTION: DC bus capacitors retain hazardous voltages after input power has been disconnected. After disconnecting input power, wait five minutes for the DC bus capacitors to discharge and then check the voltage with a voltmeter to ensure the DC bus capacitors are discharged before touching any internal components. Failure to observe this precaution could result in severe bodily injury or loss of life.

ATTENTION: The drive contains printed circuit boards that are static-sensitive. An anti-static wrist band should be worn by any person who touches the drive's components, connectors, or wiring. Erratic machine operation and damage to, or destruction of, equipment can result if this procedure is not followed. Failure to observe this precaution could result in bodily injury.

Use this procedure to install the RMI board in the drives listed in table 3.7.

Table 3.7 – Model Numbers for 200 to 400 HP @ 460VAC Drives

GV3000	VTAC 7
200V41xx 200V41xxDS	200H41xx
250V41xx 250V41xxDS	250H41xx
300V41xx 300V41xxDS	300H41xx
350V41xx 350V41xxDS	350H41xx
400V41xx 400V41xxDS	400H41xx

Unless otherwise indicated, keep all hardware that is removed. You will need it for reassembly. This includes screws, lock washers, and rivets.

Important: Read and understand the warning labels on the outside of the drive before proceeding.

Step 1. Shut Down the Drive

Step 1.1 Disconnect, lock out, and tag all incoming power to the drive.

Step 1.2 Wait five minutes for the DC bus capacitors to discharge.

Important: Read and understand the warning labels on the inside of the drive before proceeding.

Step 2. Verify That the DC Bus Capacitors are Discharged

Step 2.1 Open the drive's outer cabinet door.

Step 2.2 Lower the plastic terminal strip shield at the top of the drive.

Step 2.3 Use a voltmeter to verify that there is no voltage at the drive's AC input power terminals, R, S, and T.

Step 2.4 Replace the plastic terminal strip shield.

Step 2.5 Ensure that the DC bus capacitors are discharged. To check DC bus potential:

- a. Stand on a non-conductive surface and wear insulated gloves. (600 V)
- b. Use a voltmeter to check the DC bus potential at the Voltmeter Test Points on the Power Module Interface board. See figure 3.16.

Step 3. Remove the Keypad Bracket from the Drive

Refer to figure 3.16 for component locations.

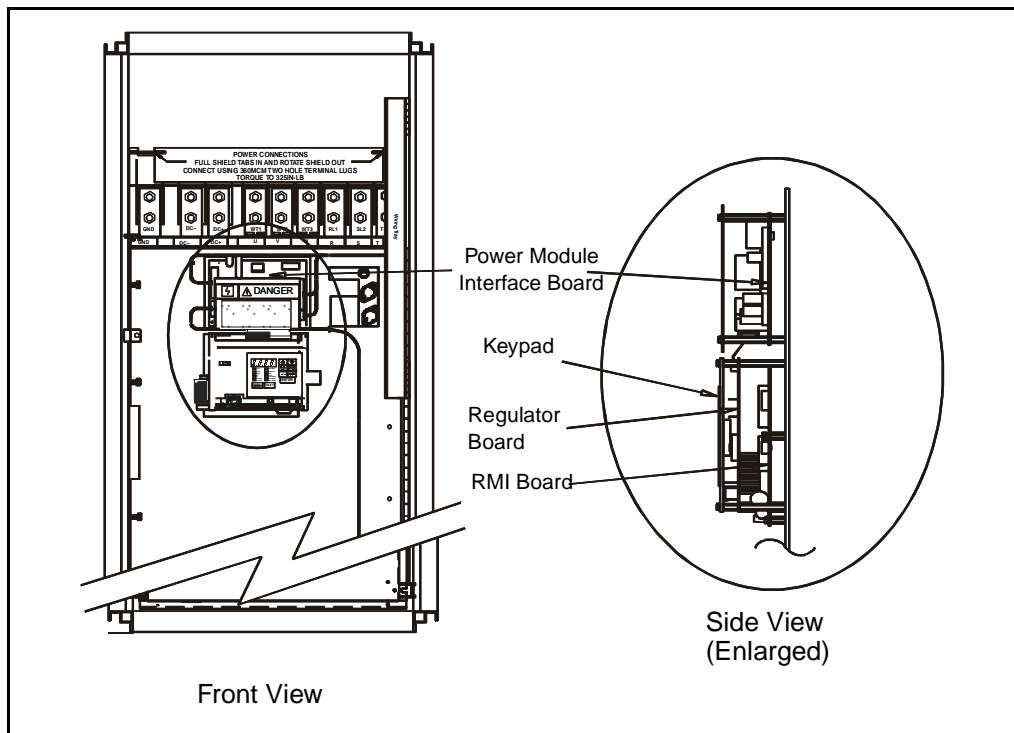

Figure 3.16 – RMI Board Location in 200 to 400HP @ 460VAC Drives

- Step 3.1 Record connections to the Regulator board terminal strip if they must be disconnected to remove the keypad bracket.
- Step 3.2 Use a magnetic screwdriver to remove the four screws and lock washers that fasten the keypad bracket to the hinged mounting panel. Hold the keypad bracket as you remove the screws.
- Step 3.3 Disconnect the Regulator board ribbon cable from the Power Module Interface board.

Step 4. Install the RMI Board



ATTENTION: The RMI board contains components that are static-sensitive. An anti-static wrist band should be worn by any person who touches the board's components, connectors, or wiring. Failure to observe this precaution could result in damage to the RMI board.

- Step 4.1 Remove the RMI board from its anti-static wrapper and verify that the jumper settings are correct. Refer to figure 2.1 for jumper locations and appendix A for jumper settings.

The RMI board mounts on four standoffs behind the Regulator board.
- Step 4.2 Align the RMI board's four mounting holes with the four standoffs on the hinged mounting panel of the drive.
- Step 4.3 Fasten the board to the drive with four $\frac{7}{32}$ " nuts. Metal nuts must be used for proper grounding of the RMI board.
- Step 4.4 Connect the RMI wiring to the appropriate RMI terminals for your application. Refer to section 3.9 for terminal identification. Route the wiring through the signal wiring tray on the right side of the drive.
- Step 4.5 Align the key on the Regulator board's 34-conductor ribbon cable connector with the slot in the RMI board's connector. Press the ribbon cable connector in until it locks into position.

Step 5. Reinstall the Keypad Bracket in the Drive

- Step 5.1 Align the key on the connector from the Regulator board with the key of the connector on the Power Module Interface board. Press the ribbon cable connector in until it locks into position.
- Step 5.2 Reconnect the keypad bracket to the hinged mounting panel using the four screws removed earlier.
- Step 5.3 Reconnect any wiring that was removed from the Regulator board terminal strip. Refer to the terminal connections documented in step 3.1 or to the appropriate instruction manuals for the devices being used.
- Step 5.4 Close and secure the outer cabinet door of the drive.
- Step 5.5 Remove the lockout and tag. Apply power to the drive. SELF will be displayed while the drive performs power-up diagnostics.

This completes the hardware installation of the RMI board. Refer to chapter 4 for the required software parameter settings for your drive.

3.8 Installing the RMI Board in 2 to 43 Amp GV3000/SE Bookshelf Drives



ATTENTION: Only qualified electrical personnel familiar with the construction and operation of this equipment and the hazards involved should install, adjust, operate, or service this equipment. Read and understand this manual and other applicable manuals in their entirety before proceeding. Failure to observe this precaution could result in severe bodily injury or loss of life.

ATTENTION: The drive is at line voltage when connected to incoming AC power. Disconnect, lock out, and tag all incoming power to the drive before performing the following procedure. Failure to observe this precaution could result in severe bodily injury or loss of life.

ATTENTION: DC bus capacitors retain hazardous voltages after input power has been disconnected. After disconnecting input power, wait five minutes for the DC bus capacitors to discharge and then check the voltage with a voltmeter to ensure the DC bus capacitors are discharged before touching any internal components. Failure to observe this precaution could result in severe bodily injury or loss of life.

ATTENTION: The drive contains printed circuit boards that are static-sensitive. An anti-static wrist band should be worn by any person who touches the drive's components, connectors, or wiring. Erratic machine operation and damage to, or destruction of, equipment can result if this procedure is not followed. Failure to observe this precaution could result in bodily injury.

Use the procedure in this section to install the RMI board in the drives listed in table 3.8.

Table 3.8 – Model Numbers for 2 to 43 Amp GV3000/SE Bookshelf Drives

2 to 15 Amp	24 to 30 Amp	43 Amp
31ER40xx 31ET40xx	240ER40xx 240ET40xx	430ER40xx 430ET40xx
38ER40xx 38ET40xx	300ER40xx 300ET40xx	
55ER40xx 55ET40xx		
85ER40xx 85ET40xx		
126ER40xx 126ET40xx		
150ER40xx 150ET40xx		

This procedure requires access to the right side of the drive. Remove the drive from the panel if necessary.

Unless otherwise indicated, keep all hardware that is removed. You will need it for reassembly. This includes screws, lock washers, and rivets.

Important: Read and understand the warning labels on the outside of the drive before proceeding.

Step 1. Shut Down the Drive

Step 1.1 Disconnect, lock out, and tag all incoming power to the drive.

Step 1.2 Wait five minutes for the DC bus capacitors to discharge.

Step 1.3 Disconnect all faceplate wiring.

Step 1.4 2 to 15 A drives: Remove the cover by removing the cover screw on the faceplate of the drive. See figure 3.17.

24 to 43A drives: Remove the cover by removing the cover screw on the faceplate of the drive. Then remove the front panel by removing the two screws on the faceplate of the drive. See figure 3.18 or 3.19.

Important: The cover is connected to the drive by the keypad/display cable. To disconnect the cover, use the following procedure. Do not remove the keypad/display.

To remove the cover:

- a. Unscrew the attaching screw on the cover.
- b. Lift the cover and carefully take it out of the heatsink as far as the flat ribbon cable, which connects the display with the Regulator board, allows.
- c. Use a screwdriver to slide the cable out of the connector on the Regulator board to completely detach the cover.

Step 2. Verify That the DC Bus Capacitors are Discharged

Step 2.1 Use a voltmeter to verify that there is no voltage at the drive's AC input power terminals (R/L1, S/L2, T/L3). Refer to figure 3.17, 3.18, or 3.19 for the location of these terminals.

Step 2.2 Ensure that the DC bus capacitors are discharged. To check DC bus potential:

- a. Stand on a non-conductive surface and wear insulated gloves.
- b. Use a voltmeter to measure the DC bus potential at the DC bus power terminals ((-)45, (+)47) shown in figure 3.17, 3.18, or 3.19

Step 2.3 24 to 43 A drives: Reattach the front panel after checking the DC bus potential.

Step 3. Install the RMI Board in the Drive



ATTENTION: The drive contains printed circuit boards that are static-sensitive. An anti-static wrist band should be worn by any person who touches the drive's components, connectors, or wiring. Erratic machine operation and damage to, or destruction of, equipment can result if this procedure is not followed. Failure to observe this precaution could result in bodily injury.

- Step 3.1 Remove the RMI board from its anti-static wrapper and verify that the jumper settings are correct. Refer to figure 2.1 for jumper locations and appendix A for jumper settings.
- Step 3.2 Align the key on the Regulator board's 34-conductor ribbon cable connector with the slot in the RMI board's connector. Press the ribbon cable connector in until it locks into position.
- Step 3.3 Fasten the RMI board to the drive using the screws provided.

Step 4. Reattach the Cover

- Step 4.1 Remove the tabs on the faceplate breakout panel.
- Step 4.2 Reconnect the keypad/display cable to the cover.
- Step 4.3 Connect the RMI wiring to the appropriate RMI terminals for your application. Refer to section 3.9 for terminal identification.

Important: When replacing the cover on 24 to 43 A drives, check that the display cable is reconnected to the Regulator board. You will need to fold and route the cable under the heatsink before replacing the cover.

- Step 4.4 Reattach the cover using the single faceplate screw.
- Step 4.5 Reconnect all faceplate wiring.
- Step 4.6 Remove the lockout and tag. Apply power to the drive. SELF will be displayed while the drive performs power-up diagnostics.
- Step 4.7 This completes the hardware installation of the RMI board. Refer to chapter 4 for the required software parameter settings for your drive.

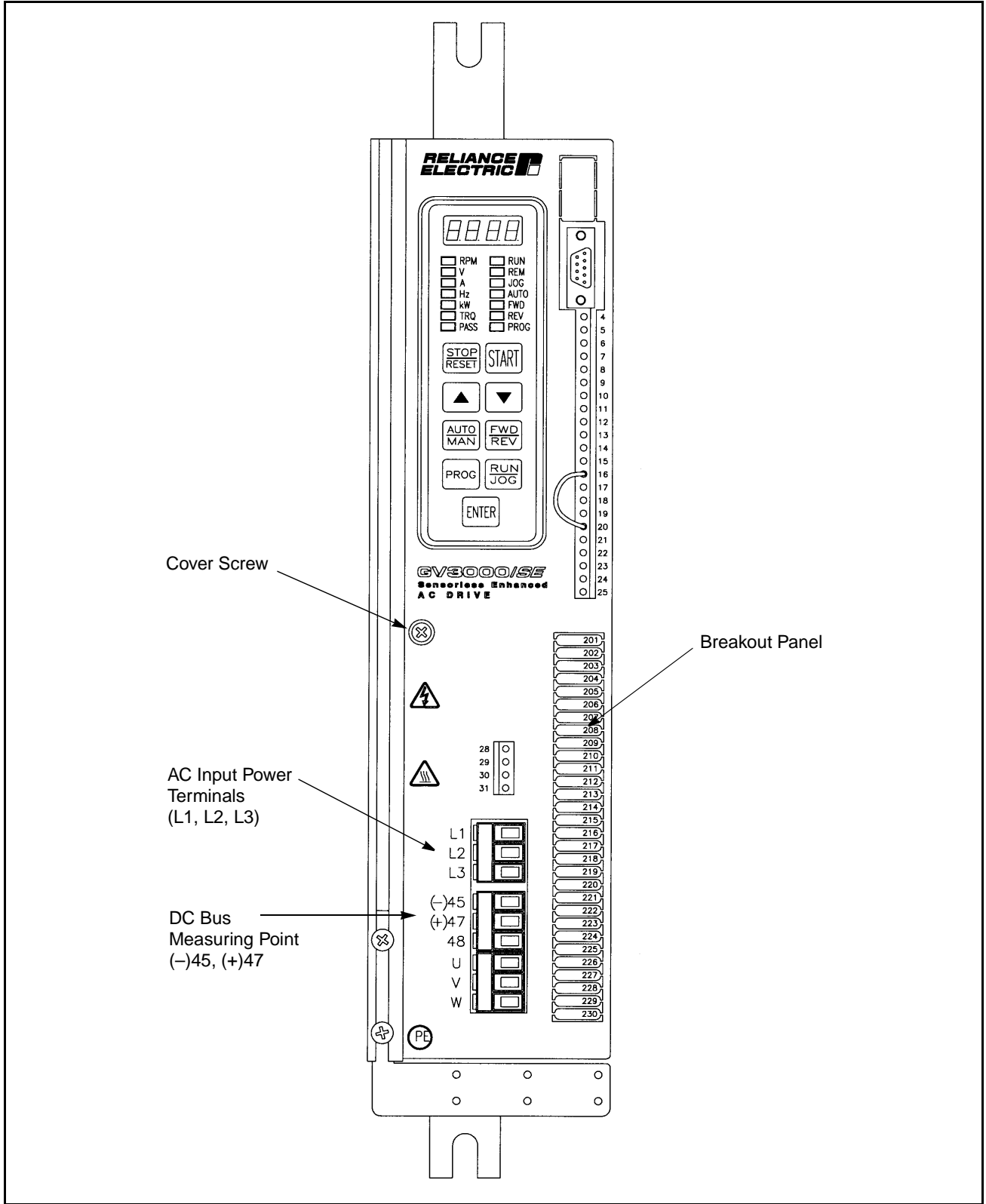

Figure 3.17 – 2 to 15 Amp GV3000/SE Bookshelf Drive

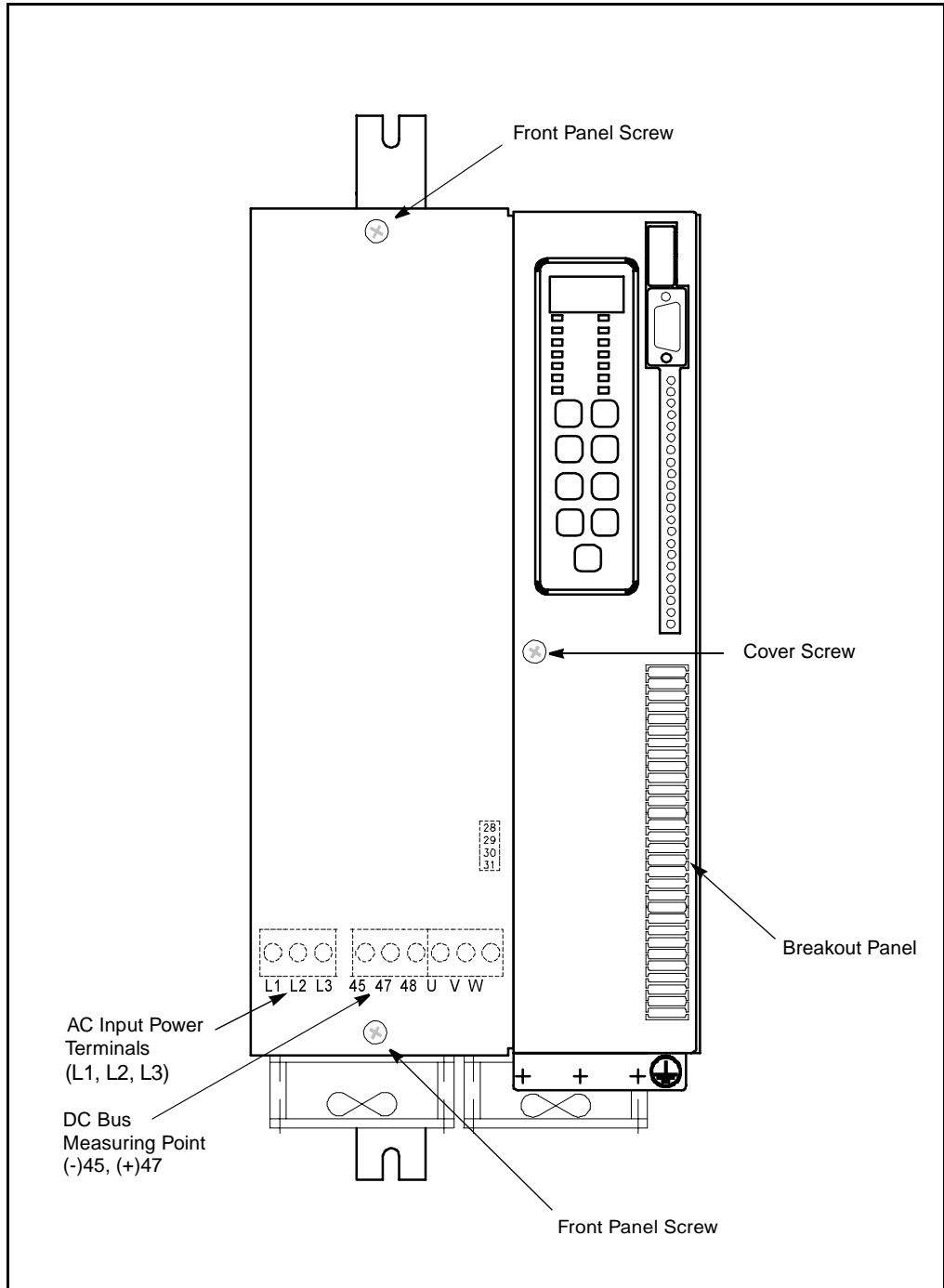

Figure 3.18 – 24 to 30 Amp GV3000/SE Bookshelf Drive

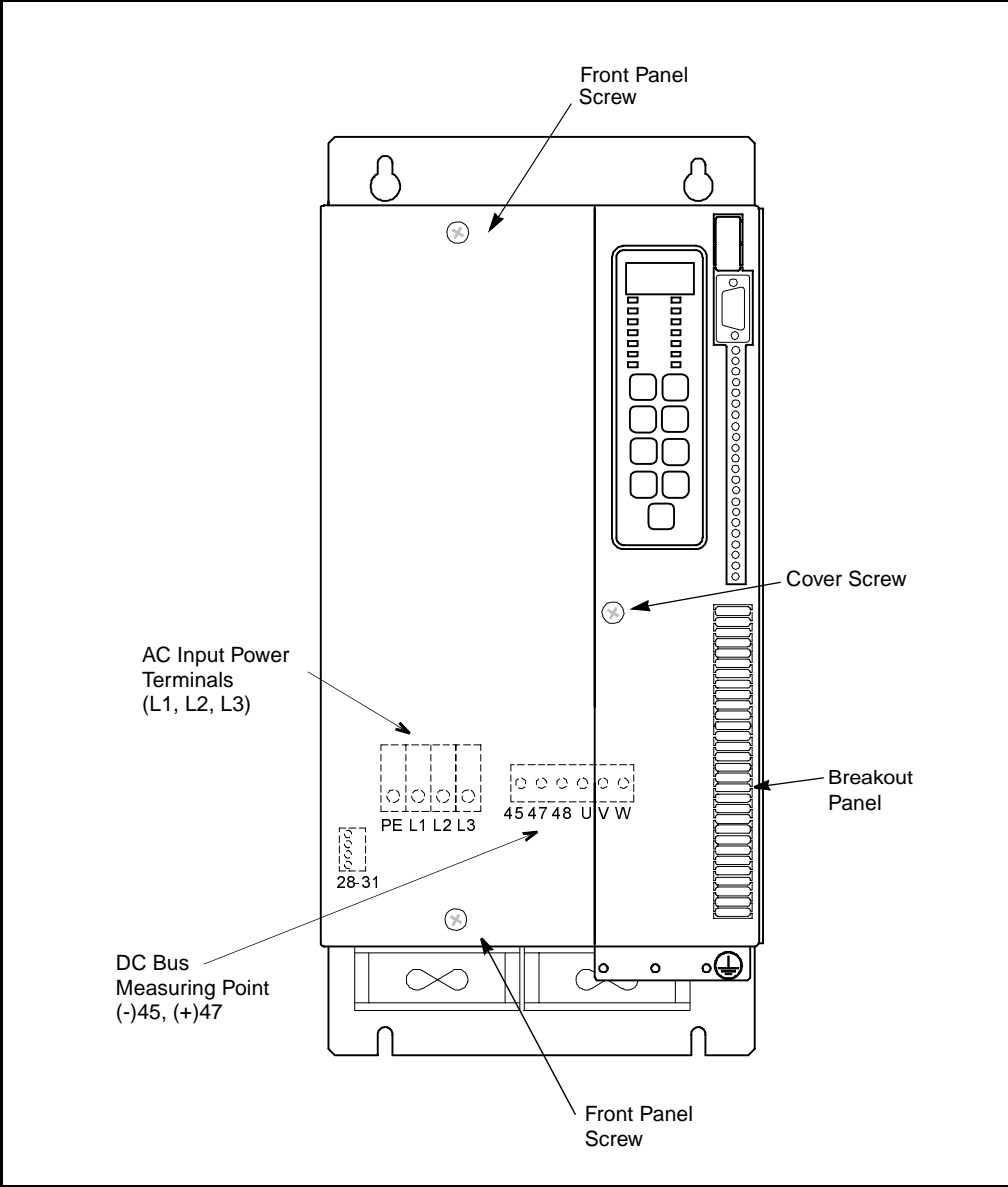

Figure 3.19 – 43 Amp GV3000/SE Bookshelf Drive

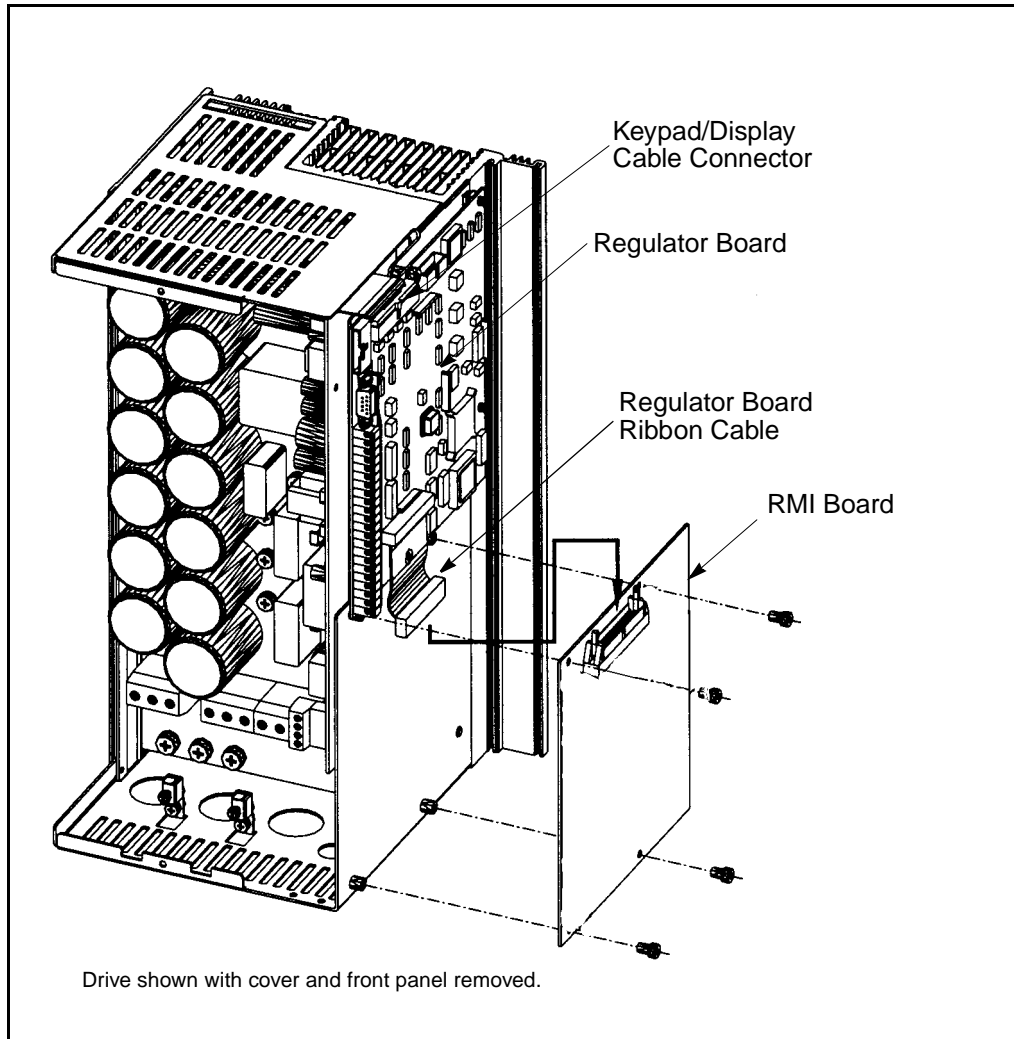



Figure 3.20 – Installing the RMI Board in a Bookshelf Drive

3.9 Wiring to the RMI Board Terminal Strip



ATTENTION: The user is responsible for conforming with all applicable local, national, and international codes. Failure to observe this precaution could result in damage to, or destruction of, the equipment.

Refer to figure 3.21 for the signal and control I/O terminal connections on the RMI board. Table 3.9 describes terminal strip connections and related parameters. Refer to the drive hardware instruction manual for wiring guidelines.

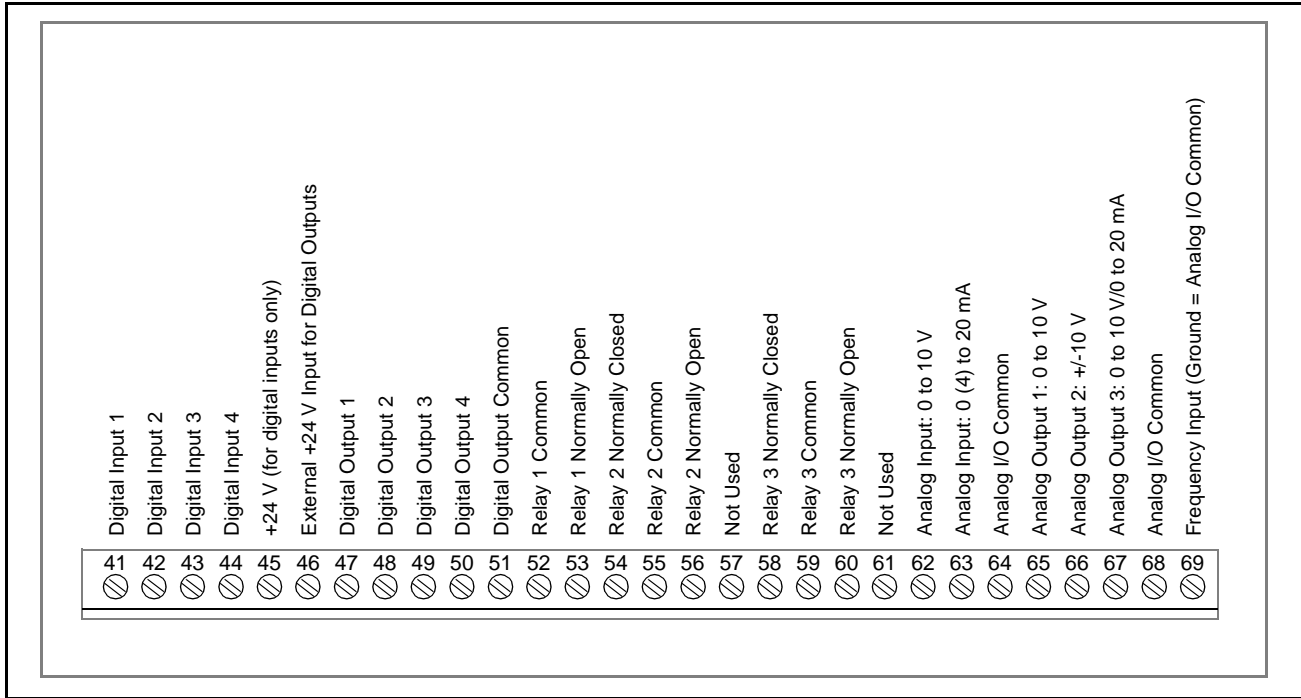

Figure 3.21 – Terminal Connections on the RMI Board

Table 3.9 – Wiring Signal and Control I/O to the RMI Board Terminal Strip

Terminal Number	Description	Related Parameters, Specifications, and Jumpers
Digital Inputs, Control Voltage Output		
41 42 43 44	Digital Input 1 Digital Input 2 Digital Input 3 Digital Input 4	The four digital inputs are configured using parameter r.030.
45	+24 VDC Supply, Control Voltage Output	Current-limited and isolated. This supply should not be used as an external supply for anything other than the four digital inputs.
46	24 VDC Supply, Control Voltage Input	100 mA per output with an external power supply. Jumper 24 V EXT
47 48 49 50	Digital Output 1 Digital Output 2 Digital Output 3 Digital Output 4	Configuration: r.031 Timer: r.040 Configuration: r.032 Timer: r.041 Configuration: r.033 Timer: r.042 Configuration: r.034 Timer: r.043 20 mA per output with jumper set to 24 V INT
51	Common	Digital I/O common
Relay Outputs		
Relay 1		
52 53	Common Normally Open Contact	Configuration: r.035 Timer: r.044
Relay 2		
54 55 56	Normally Closed Contact Common Normally Open Contact	Configuration: r.036 Timer: r.045
Relay 3		
58 59 60	Normally Closed Contact Common Normally Open Contact	Configuration: r.037 Timer: r.046
Analog Inputs, Frequency Input		
62	Voltage Signal Input	+10 VDC supply, isolated, stabilized, max. 2.7 mA; jumper setting: V IN (default)
63	Current Signal Input	0 to 20 mA Analog current speed reference input; jumper setting: C IN
69	Frequency Input	0 to 200 kHz
64	Analog I/O Common	Isolated common for voltage/current or frequency input.

Table 3.9 – Wiring Signal and Control I/O to the RMI Board Terminal Strip (Continued)

Terminal Number	Description	Related Parameters, Specifications, and Jumpers
Analog Outputs		
65	Analog Output No. 1 0 to 10 VDC	Configuration: r.001 Offset: r.002 Gain: r.003
66	Analog Output No. 2 –10 to +10 VDC	Configuration: r.004 Offset: r.005 Gain: r.006
67	Analog Output No. 3 V OUT: 0 to 10 VDC C OUT: 0 to 20 mA	Configuration: r.007 Offset: r.008 Gain: r.009
68	Analog Common	Common for all analog outputs.

Terminals 57 and 61 are not used.

Programming Reference

A set of parameters used specifically with the RMI board is accessible when the RMI board is connected to the drive. The parameters are in the Second Menu, as shown in figure 4.1. RMI parameters have a lower case r as the first character. If the RMI board is not properly connected, the r parameters will not be displayed.

This chapter describes the r parameters. All other drive parameters are described in the drive software instruction manual. Use the appendix in the software manual to record the r parameter settings for your configuration.

Note that vector regulation (including U parameters) does not apply to VTAC 7 drives.

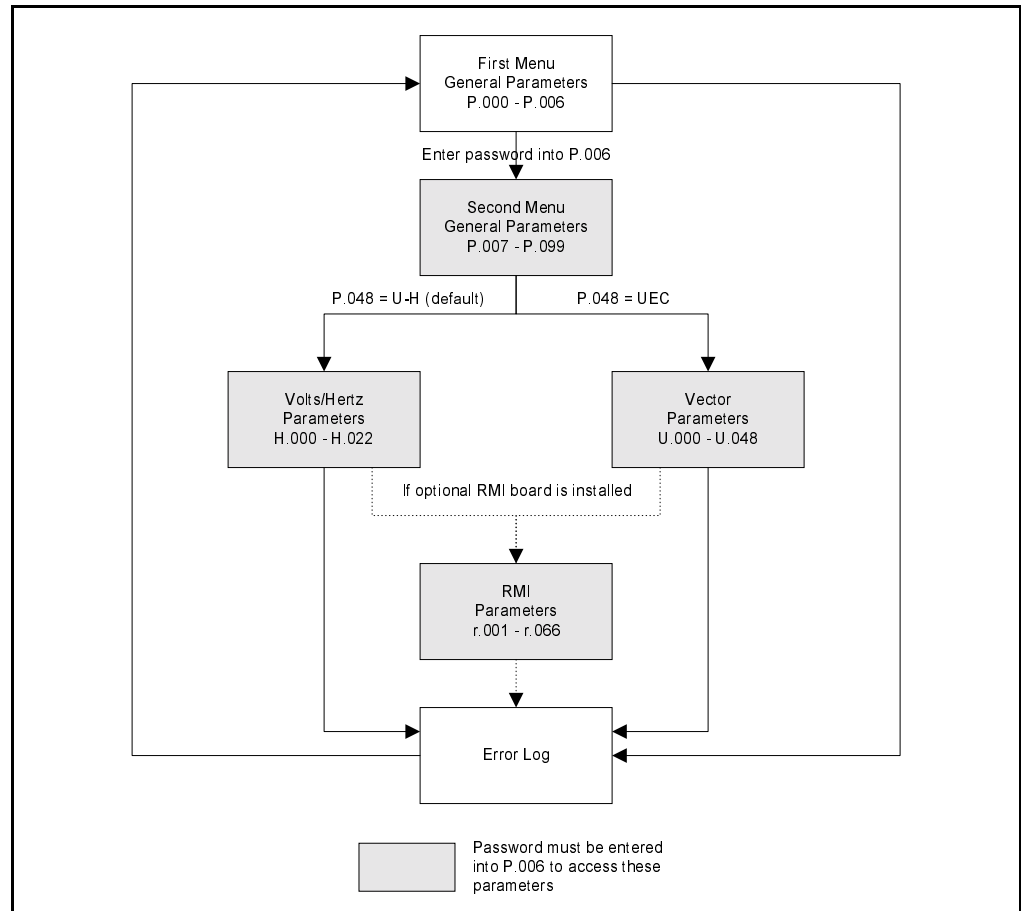

Figure 4.1 – Parameter Menu Structure

4.1 RMI Parameter Descriptions

r.001 to r.099 Analog Outputs

Par.	Parameter Name	Type	Default	Step	Range
r.001	Analog Output 1 Source	Config.	1	1	0 to 8 (Table 4.1)
r.002	Analog Output 1 Offset	Tunable	0	1	-4095 to +4095
r.003	Analog Output 1 Gain	Tunable	1.000	0.001	0.100 to 5.000
r.004	Analog Output 2 Source	Config.	2	1	0 to 8 (Table 4.1)
r.005	Analog Output 2 Offset	Tunable	0	1	-4095 to +4095
r.006	Analog Output 2 Gain	Tunable	1.000	0.001	0.100 to 5.000
r.007	Analog Output 3 Source	Config.	3	1	0 to 8 (Table 4.1)
r.008	Analog Output 3 Offset	Tunable	0	1	-4095 to +4095
r.009	Analog Output 3 Gain	Tunable	1.000	0.001	0.100 to 5.000

Table 4.1 – Analog Output Source Selections for r.001, r.004, and r.007

Analog Output Selection	Scaling (Max. 4095)	Update	Filter*
0 = Not used	Output = 0	100 ms	none
1 = Motor Voltage	Max. = H.000 x 1.1 (V/Hz) U.007 x 1.1 (Vector)	100 ms	0.5 sec
2 = Motor Current	Max. = H.002 x 1.5 (V/Hz) U.004 x 1.5 (Vector)	5 ms	none
3 = Speed Reference	Max. = P.004 (V/Hz) U.017 (Vector)	5 ms	none
4 = Motor Speed or Frequency	Max. = P.004 (V/Hz) U.017 (Vector)	5 ms	none
5 = Motor Torque	Max. = 150%	100 ms	0.5 sec
6 = Motor Power kW	Max. = H.000 x H.002 x 1.5 x 1.73 (V/Hz) U.007 x U.004 x 1.5 x 1.73 (Vector)	100 ms	0.5 sec
7 = DC Bus Voltage	Max. = 1.75 x panel volts	5 ms	none
8 = PI Output	Max. = Max. PI regulator output	100 ms	none

* Filter outputs are suitable for metering purposes only.

Analog output 3 is jumper-selected between voltage or current signals (refer to table 2.3). The default current range is 0 to 20mA. Further adjustments in current offset and range can be programmed. For example, for a range of 4 to 20mA on output 3:

$$r.008 \text{ (Offset)} = +819 \text{ and } r.009 \text{ (Gain)} = 0.8$$

The data from the regulator to the analog outputs is normalized so that 4095 corresponds to positive full scale. Additional gain and offset calculation is done by the RMI board. For outputs 1 and 3, the drive will take the absolute value of the data. The value for output 2 may be signed (± 4095).

r.010, r.011 Analog Input

Par.	Parameter Name	Type	Default	Step	Range
r.010	Analog Input Offset	Tunable	0	1	-3700 to +3700
r.011	Analog Input Gain	Tunable	1.000	0.001	-5.000 to +5.000

The 10-bit analog input can be used for speed reference or trim reference. Refer to figure 4.4. The input is jumper-selected between voltage or current signals in the range 0 to 10 volts or 0 to 20 mA.

The data from the analog input is normalized so that 4095 corresponds to positive full scale. The RMI board reads the analog input every scan (1.0ms) and computes a running sum over four scans. After summing, the RMI board adds the input offset and multiplies by the gain. The offset adjustment is used to compensate for analog offsets to compensate for minimal speed setting, and to support a bi-directional speed reference. When the gain is a negative value, the input signal will be inverted.

r.014, r.015, r.016 Frequency Input

Par.	Parameter Name	Type	Default	Step	Range
r.014	Frequency Input Sample Period	Tunable	5	1	5 to 500
r.015	Frequency Input Offset	Tunable	0	1	-2048 to +2048
r.016	Frequency Input Gain	Tunable	1.000	0.001	-5.000 to +5.000

The frequency input can be used for speed or trim reference. Refer to figure 4.4. The input operates from 0 to 200kHz. The RMI board samples the number of cycles detected every scan (1.0ms) and computes a running sum of the last N scans. The number of samples is selected in r.014.

If the number of samples is greater than 20, it is rounded up to the next multiple of 20. The running sum is limited to a maximum value of 32000.

After summing, the RMI board adds an offset and multiplies by a gain. Offset adjustment is used to compensate for minimal speed setting and to support a bi-directional speed reference. When the gain is a negative value, the input signal will be inverted.

Important: The running sum will be limited to 32000. Do not set the number of samples too high.

Running Sum Example				
For a 200 kHz reference frequency and 500 samples:				
Number of Samples	x	Reference Pulses per ms	=	Running Sum
500	x	200	=	100,000
Note that with a 200 kHz reference frequency, the number of samples must be reduced to about 160:				
160	x	200	=	32,000

r.020, r.021, r.022 Outer Loop PI Regulator

Par.	Parameter Name	Type	Default	Step	Range
r.020	PI Regulator Offset	Tunable	0	1	-4095 to +4095
r.021	PI Regulator Proportional Gain	Tunable	5.00	0.01	0.10 to 50.00
r.022	PI Regulator Integral Gain	Tunable	0.05	0.01	0.00 to 10.00

The outer loop PI regulator output is used to adjust the trim reference. The input to the PI regulator (ERROR) is computed as:

$$\text{ERROR} = \text{REFERENCE} + \text{OFFSET} - \text{FEEDBACK}$$

Where:

OFFSET = r.020

FEEDBACK = RMI Analog Input

REFERENCE is PI regulator mode-dependent:

- For Mode 1, the reference is zero.
- For Mode 2, the selected speed reference is used, but the reference into the speed summing junction is set to zero as shown in figure 4.2.

The PI regulator mode is determined by the Trim Reference Source parameter (P.014) as shown in table 4.2. If P.014 is set to a value other than 8 or 9, the PI regulator will remain inactive. Figure 4.2 illustrates these modes.

Table 4.2 – Regulator Operating Modes

PI Regulator Mode	PI Regulator Reference Used	PI Regulator Offset Used	Feedback Used
Mode 1 (P.014 = 8)	Zero	r.020	RMI Analog Input
Mode 2 (P.014 = 9)	Selected by P.000	r.020	RMI Analog Input
Inactive (P.014 8 or 9)	Not Used	Not Used	Not Used

The outer loop PI regulator is evaluated every 20ms in the regulator. The PI regulator is enabled only when the drive is in run. If the drive is jogged, the PI regulator will remain reset.

Digital input 4 on the RMI board can be programmed as PI-Enable by setting r.030 (Digital Input Configuration) to 1, 3, 5, or 7. The PI regulator is then enabled only when the drive is in run and digital input 4 is on. If r.030 is not set to 1, 3, 5, or 7, the PI regulator is enabled whenever the drive is in run

r.020, r.021, r.022 Outer Loop PI Regulator (continued)

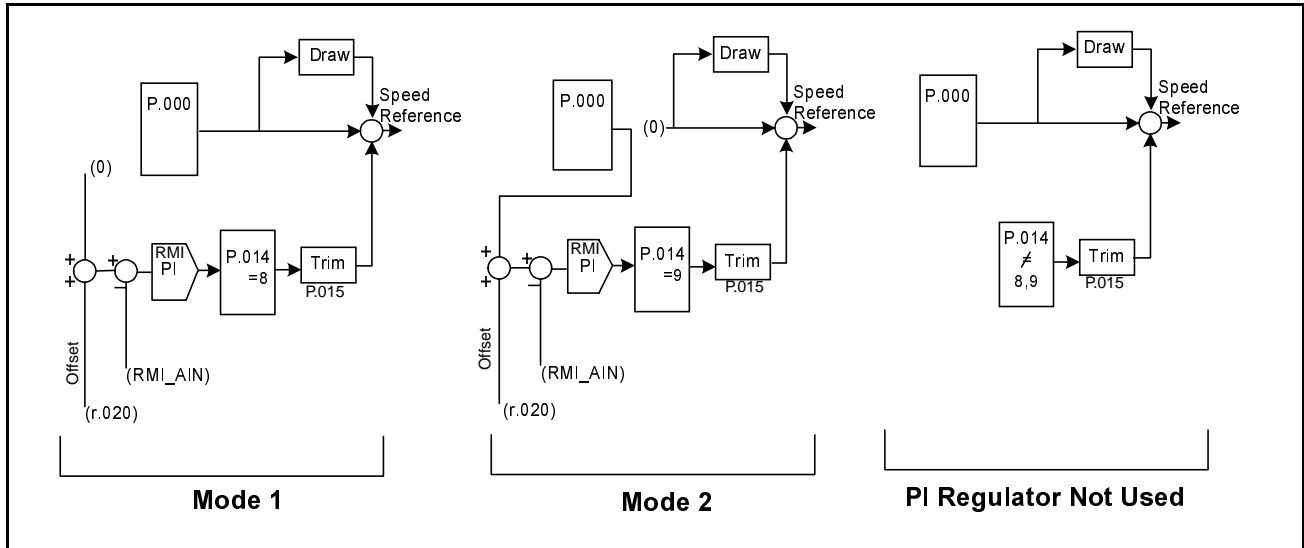

Figure 4.2 – PI Regulator Operating Modes

r.025 Torque or Current Limit Selection

Par.	Parameter Name	Type	Default	Step	Range
r.025	Torque/Current Limit Source	Config.	0	1	0 = No adjustable limit. 1 = Limit adjusted based on normalized RMI analog input. 2 = Limit adjusted based on normalized RMI frequency input.

The RMI board provides the option to make the torque limit and current limit a function of the RMI analog input or the RMI frequency input, depending on r.025. When the RMI board is not present, there is no adjustable limit.

For vector regulation, the torque limit can be adjusted. For V/Hz regulation, the current limit can be adjusted. The value of r.025 determines the source for the limit. When r.025 = 0, the limit is set to 4095. When r.025 = 1 or 2, the limit comes from the RMI board. This can be the RMI analog input or the RMI frequency input. The output of the torque limit is normalized so that 4095 corresponds to 150%. The output of the current limit is normalized so that 4095 corresponds to 200%.

r.025 Torque or Current Limit Selection *(Continued)*

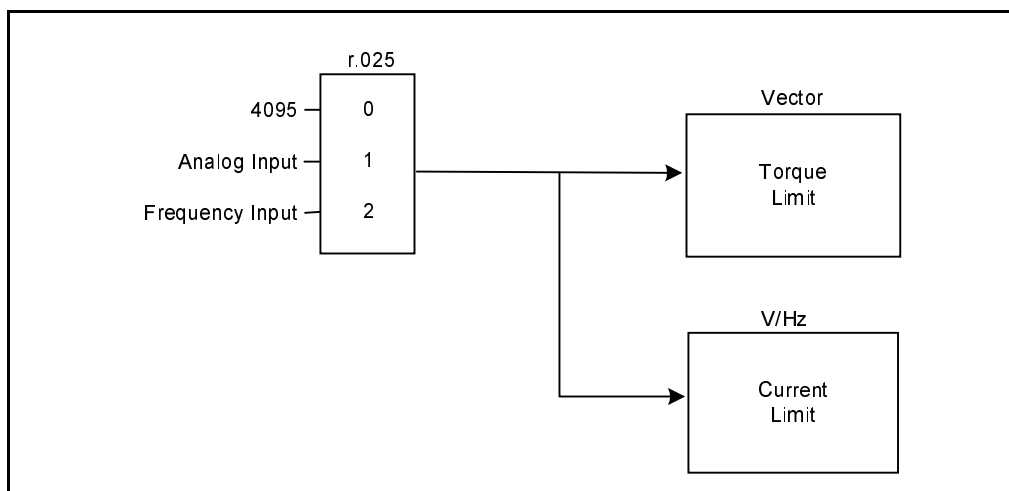

Figure 4.3 – Torque or Current Limit Selection

r.030 Digital Input Configuration

Par.	Parameter Name	Type	Default	Step	Range
r.030	Digital Input Configuration	Config.	0	1	0 to 8 (Table 4.3)

Table 4.3 – Digital Input Configuration Selections for r.030

r.030	Digital Input 1 (DIGIN 1)	Digital Input 2 (DIGIN 2)	Digital Input 3 (DIGIN 3)	Digital Input 4 (DIGIN 4)
0 =	Reference 1 / 2	Analog / Freq	Aux Input 2	Aux Input 1
1 =	Reference 1 / 2	Analog / Freq	Aux Input 2	PI-Enable
2 =	Reference 1 / 2	MOP ↑	MOP ↓	Aux Input 1
3 =	Reference 1 / 2	MOP ↑	MOP ↓	PI-Enable
4 =	Reference 1 / 2	2 Presets	Aux Input 2	Aux Input 1
5 =	Reference 1 / 2	2 Presets	Aux Input 2	PI-Enable
6 =	Reference 1 / 2	4 Presets	4 Presets	Aux Input 1
7 =	Reference 1 / 2	4 Presets	4 Presets	PI-Enable
8 =	Reference 1 / 2	8 Presets	8 Presets	8 Presets

The four digital inputs on the RMI board expand the options for the speed reference selection. Parameter r.030 configures the digital inputs, similar to the way P.007 configures the terminal strip inputs on the Regulator board.

Note that to use the RMI speed reference, P.000 must be set to remote (rE). If P.000 is set to option (OP) and an RMI board is used, the speed reference will be zero.

r.030 Digital Input Configuration *(Continued)*

Figure 4.4 displays the options for selecting the speed reference when the RMI board is used. Note that even with the additional options for controlling the MOP and Preset Speeds, there is still only one MOP and there are still only eight preset speeds for selection.

The shaded areas in figure 4.4 show the additional speed reference options when the RMI board is installed in the drive.

Note that when P.000 = LOCL (0) and AUTO is selected, RMI digital input 1 (DIGIN 1) is used to choose between the additional speed reference selected by P.008 and that selected by r.030.

The digital inputs are read every RMI scan (1.0 ms). The RMI board requires the input to be in the same state for 3 ms before a change in state is updated to the regulator.

For more information on digital input configuration, see the appropriate appendix in the drive software instruction manual.

The selections shown in table 4.3 are described below.

Reference 1 / 2

DIGIN 1 is used to switch the RMI speed reference between the drive's terminal strip inputs (Reference 1) and the RMI inputs (Reference 2).

If DIGIN 1 is off, the speed reference source is selected by parameter P.008.

If DIGIN 1 is on, the speed reference source is selected by parameter r.030 (see table 4.3).

Analog / Freq

DIGIN 2 can be used to switch between the RMI analog input and the RMI frequency input as the reference signal. Refer to figure 4.4.

If r.030 = 0 or 1 and DIGIN 2 is off, the RMI analog reference input (terminals 62, 63, 64) is used.

If r.030 = 0 or 1 and DIGIN 2 is on, the RMI frequency reference input (terminals 69, 64) is used.

If r.030 \neq 0 or 1, the input defaults to the RMI analog reference input (terminals 62, 63, 64).

Aux Input 1

DIGIN 4 can be programmed as an auxiliary input (Aux Input 1) by setting r.030 = 0, 2, 4, or 6. This auxiliary input can be used to turn any digital output or relay output on and off with an on-delay or an off-delay using the corresponding time delay parameter (r.040 through r.046).

If r.030 = 0, 2, 4, or 6 and DIGIN 4 is on, the Aux Input 1 function is enabled to control the selected digital output or relay output.

If r.030 = 1, 3, 5, 7, or 8, the Aux Input 1 function is always off.

Figure 4.4 – Speed Reference Options

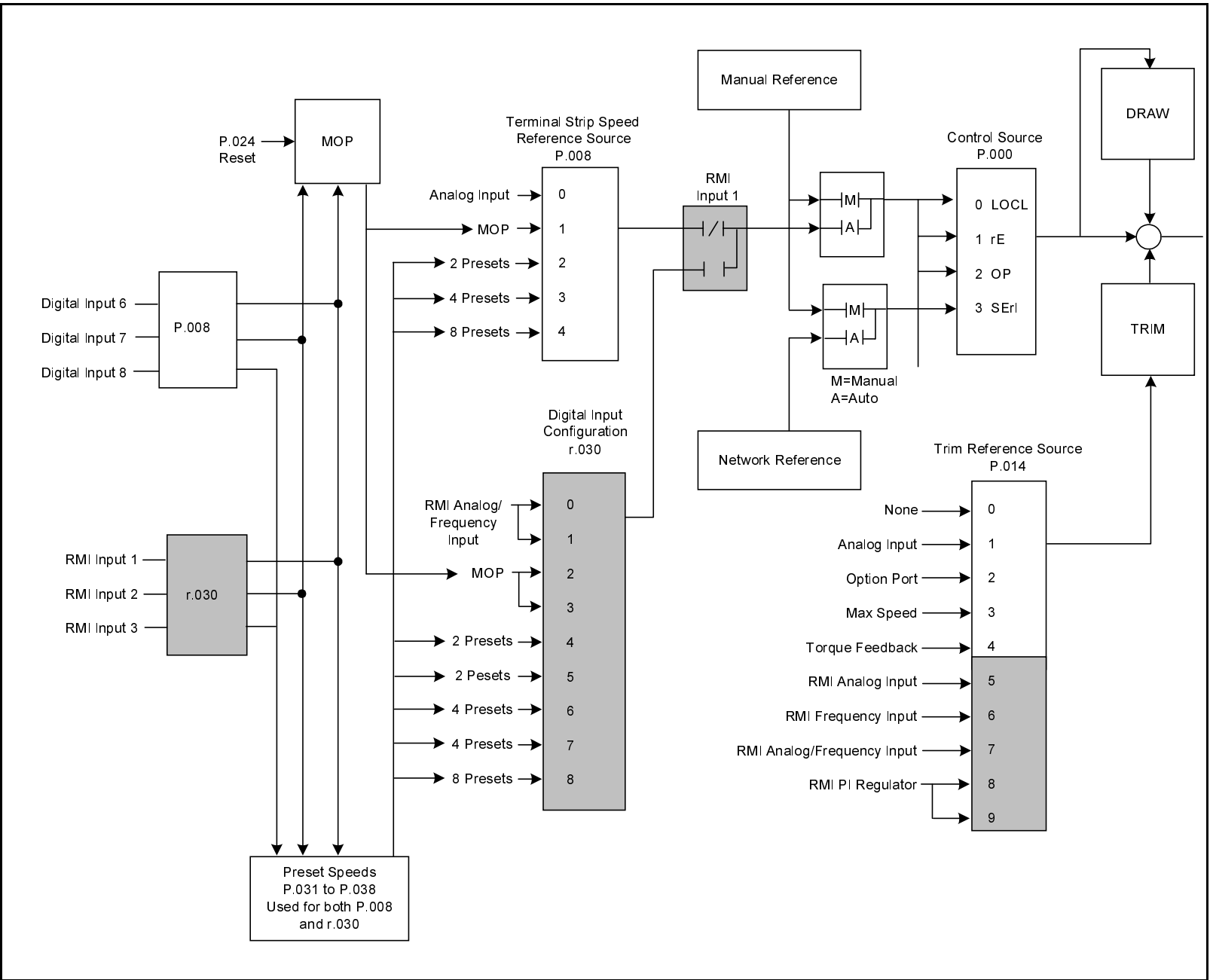

r.030 Digital Input Configuration (Continued)

r.030 Digital Input Configuration *(Continued)*

Aux Input 2

DIGIN 3 can be programmed as an auxiliary input (Aux Input 2) by setting r.030 = 0, 1, 4, or 5. This auxiliary input can be used to turn any digital output or relay output on and off with an on-delay or an off-delay using the corresponding time delay parameter (r.040 through r.046).

If r.030 = 0, 1, 4, or 5 and DIGIN 3 is on, the Aux Input 2 function is enabled to control the selected digital output or relay output.

If r.030 = 2, 3, 6, 7, or 8, the Aux Input 2 function is always off.

PI-Enable

DIGIN 4 can be used to enable the outer loop PI regulator. If the PI regulator is not enabled, the output of the PI regulator is held in reset (0).

If r.030 = 1, 3, 5, or 7, the PI regulator is enabled only when the drive is in run and DIGIN 4 is on.

If r.030 \neq 1, 3, 5, or 7, the PI regulator is enabled whenever the drive is in run.

MOP \uparrow , MOP \downarrow

DIGIN 2 and DIGIN 3 can be used to increase or decrease the MOP. This option is available only when P.008 (Terminal Strip Speed Reference Source) \neq 1. Similarly, if r.030 is set to 2 or 3, P.008 cannot be set to 1.

If r.030 = 2 or 3 and DIGIN 2 is on, the MOP is increased.

If r.030 = 2 or 3 and DIGIN 3 is on, the MOP is decreased.

Preset Speeds

DIGIN 2, 3, and 4 can be used to select preset speeds. One speed reference is selected from two, four, or eight possible preset speeds. This option is available only when P.008 (Terminal Strip Speed Reference Source) \neq 2 through 7. In addition, if r.030 is set to 4 through 8, P.008 cannot be set to 2 through 7. See the drive software instruction manual for a description of the Preset Speed parameters, which are P.031 to P.038.

2 Presets

If r.030 = 4 or 5, Preset Speed P.031 or P.032 is selected by DIGIN 2. See table 4.4.

4 Presets

If r.030 = 6 or 7, one of Preset Speeds P.031 to P.034 is selected by DIGIN 2 and DIGIN 3. Refer to table 4.4.

r.030 Digital Input Configuration *(Continued)*

8 Presets

If r.030 = 8, one of Preset Speeds P.031 to P.038 is selected by DIGIN 2 to DIGIN 4. See table 4.4.

Table 4.4 – Preset Speed Digital Inputs

Digital Inputs (Terminals)			Selected Speed Reference
DIGIN 4 (44)	DIGIN 3 (43)	DIGIN 2 (42)	
OFF	OFF	OFF	P.031
OFF	OFF	ON	P.032
OFF	ON	OFF	P.033
OFF	ON	ON	P.034
ON	OFF	OFF	P.035
ON	OFF	ON	P.036
ON	ON	OFF	P.037
ON	ON	ON	P.038

r.031 to r.037 Digital Output and Relay Outputs Configuration

Par.	Parameter Name	Type	Default	Step	Range
r.031	Digital Output 1 Configuration	Config.	0	1	0 to 21 (Table 4.5)
r.032	Digital Output 2 Configuration				
r.033	Digital Output 3 Configuration				
r.034	Digital Output 4 Configuration				
r.035	Relay Output 1 (NO) Configuration				
r.036	Relay Output 2 (NO/NC) Configuration				
r.037	Relay Output 3 (NO/NC) Configuration				

The RMI board's digital and relay outputs are turned on or off as a function of 20 possible comparisons. The values in r.031 through r.037 select the comparison to use for a particular output.

Table 4.5 – Digital Outputs and Relay Outputs Configuration Selections

Selection	Description	Update Time
0 = Not Used	The output is always off.	N/A
1 = Running	The output is turned on when the drive is in run.	20 ms
2 = Fault	The output is turned on when there is a fault.	20 ms
3 = Aux Input 1	The output is turned on or off (time delayed) as a function of the Aux 1 input (digital input 4). If digital input 4 is not programmed as Aux 1, the output will be off.	100 ms

Table 4.5 – Digital Outputs and Relay Outputs Configuration Selections (Continued)

Selection	Description	Update Time
4 = Aux Input 2	The output is turned on or off (time delayed) as a function of the Aux 2 input (digital input 3). If digital input 3 is not programmed as Aux 2, the output will be off.	100 ms
5 = Speed Level 1	<p>The output is turned on when the absolute value of speed or frequency is greater than or equal to Speed Detection Level 1 (r.050). The output is turned off when the absolute value of speed or frequency is less than or equal to Speed Detection Level 1 minus the Speed Detection Hysteresis Band (r.053).</p>  <p>H = Hysteresis (r.053), L = Level (r.050 to r.052)</p> <p>Figure 4.5 – Speed Level 1, 2, and 3</p>	100 ms
6 = Speed Level 2	The output is turned on when the absolute value of speed or frequency is greater than or equal to Speed Detection Level 2 (r.051). The output is turned off when the absolute value of speed or frequency is less than or equal to Speed Detection Level 2 minus the Speed Detection Hysteresis Band (r.053). Refer to figure 4.5.	100 ms
7 = Speed Level 3	The output is turned on when the absolute value of speed or frequency is greater than or equal to Speed Detection Level 3 (r.052). The output is turned off when the absolute value of speed or frequency is less than or equal to Speed Detection Level 1 minus the Speed Detection Hysteresis Band (r.053). Refer to figure 4.5.	100 ms
8 = Low Speed	<p>The output is turned on when the absolute value of speed or frequency is less than or equal to the Low Speed Detection Level (r.056). The output is turned off when the absolute value of speed or frequency is greater than or equal to the Low Speed Detection Level plus the Speed Detection Hysteresis Band (r.053).</p>  <p>H=Hysteresis (r.053), L=Level (r.056)</p> <p>Figure 4.6 – Low Speed</p>	100 ms

Table 4.5 – Digital Outputs and Relay Outputs Configuration Selections (Continued)

Selection	Description	Update Time
9 = Speed Reached	<p>The output is turned on when the absolute value of commanded speed or frequency minus actual speed or frequency is less than or equal to the Speed Detection Hysteresis Band (r.053).</p>  <p>H = Hysteresis (r.053), R = Speed Reference</p> <p>Figure 4.7 – Speed Reached</p>	100 ms
10 = Remote	<p>The output turns on when any control source other than the local keypad is selected (P.000 ≠ LOCL).</p>	100 ms
11 = Current Level 1	<p>The output is turned on when the motor current is greater than or equal to Current Detection Level 1 (r.057). The output is turned off when the motor current is less than or equal to Current Detection Level 1 minus the Current Detection Hysteresis (r.060).</p>  <p>H = Hysteresis (r.060), L = Level (r.057 to r.059)</p> <p>Figure 4.8 – Current Level 1, 2, and 3</p>	100 ms
12 = Current Level 2	<p>The output is turned on when the motor current is greater than or equal to Current Detection Level 2 (r.058). The output is turned off when the motor current is less than or equal to Current Detection Level 2 minus the Current Level Hysteresis (r.060). Refer to figure 4.8.</p>	100 ms
13 = Current Level 3	<p>The output is turned on when the motor current is greater than or equal to Current Detection Level 3 (r.059). The output is turned off when the motor current is less than or equal to Current Detection Level 3 minus the Current Level Hysteresis (r.060). Refer to figure 4.8.</p>	100 ms
14 = DC Braking Active	<p>The output turns on when DC braking is active (H.005 to H.018).</p> <p>This is available only in volts per hertz (V/Hz) regulation.</p>	100 ms

Table 4.5 – Digital Outputs and Relay Outputs Configuration Selections (Continued)

Selection	Description	Update Time
15 = Reverse Rotation	<p>For V/Hz regulation, the output is turned on when the drive is commanding reverse rotation. If the drive is stopped, the output is off, regardless of the commanded direction. If running forward, the output remains off until the drive ramps to zero, then changes direction.</p> <p>For vector regulation, the output is turned on to indicate actual reverse rotation as detected by the pulse encoder.</p>	100 ms
16 = Torque Level 1	<p>The output is turned on when absolute value of torque is greater than or equal to Torque Detection Level 1 (r.063). The output is turned off when the absolute value of torque is less than or equal to Torque Detection Level 1 minus the Torque Detection Hysteresis (r.066).</p> <div style="text-align: center;">  <p>H = Hysteresis (r.066), L = Level (r.063 to r.065)</p> </div> <p>Figure 4.9 – Torque Level 1, 2, and 3</p>	100 ms
17 = Torque Level 2	<p>The output is turned on when the absolute value of torque is greater than or equal to Torque Detection Level 2 (r.064). The output is turned off when the absolute value of torque is less than or equal to Torque Detection Level 2 minus the Torque Detection Hysteresis (r.066). See figure 4.9.</p>	100 ms
18 = Torque Level 3	<p>The output is turned on when the absolute value of torque is greater than or equal to Torque Detection Level 3 (r.065). The output is turned off when the absolute value of torque is less than or equal to Torque Detection Level 3 minus the Torque Detection Hysteresis (r.066). See figure 4.9.</p>	100 ms
19 = Speed Regulation	<p>For vector regulation, the output is off when the speed loop is bypassed and on when the speed loop is enabled.</p> <p>For V/Hz regulation, the output is on all the time.</p>	100 ms

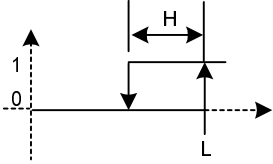
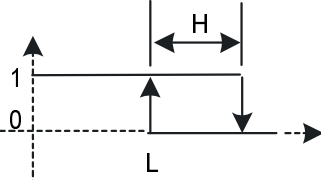
Table 4.5 – Digital Outputs and Relay Outputs Configuration Selections (Continued)

Selection	Description	Update Time
20 = Speed Reference	<p>The output is turned on when the absolute value of the selected speed reference is greater than or equal to Low Speed Detection (r.056). The output is turned off when the absolute value of the selected speed reference is less than the value in r.056 minus the Speed Detection Hysteresis Band (r.053).</p> <p style="text-align: center;">Figure 4.10 – Speed Reference</p>	
21 = TB Start & Stop	<p>The output is turned on when the terminal block Start and Stop inputs are both closed. The output is turned off when either of these inputs is open.</p>	

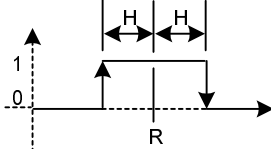
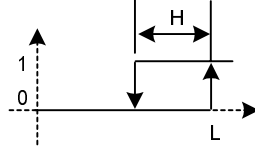
r.040 to r.046 Digital Output Relay Timers

Par.	Parameter Name	Type	Default	Step	Range
r.040	Digital Output 1 Delay Time	Tunable	0 sec	0.1	–999.9 to 999.9 sec + on-delay values – off-delay values
r.041	Digital Output 2 Delay Time				
r.042	Digital Output 3 Delay Time				
r.043	Digital Output 4 Delay Time				
r.044	Relay Output 1 Delay Time				
r.045	Relay Output 2 Delay Time				
r.046	Relay Output 3 Delay Time				

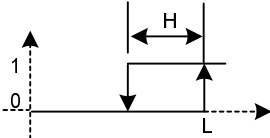
The RMI board's digital and relay outputs can be individually programmed for on-delay or off-delay. After the regulator signals an output to turn on or off, the RMI board will wait for the programmed time delay before the output is turned on or off.

r.050 to r.066 Digital Output Comparison

Par.	Parameter Name	Type	Default	Step	Range
r.050	Speed Detection Level 1	Tunable	150 RPM (Vector) 5.0 Hz (V/Hz)	1 RPM 0.1 Hz	0 RPM to P.004 0.5 Hz to P.004
r.051	Speed Detection Level 2	Tunable	150 RPM (Vector) 5.0 Hz (V/Hz)	1 RPM 0.1 Hz	0 RPM to P.004 0.5 Hz to P.004
r.052	Speed Detection Level 3	Tunable	150 RPM (Vector) 5.0 Hz (V/Hz)	1 RPM 0.1 Hz	0 RPM to P.004 0.5 Hz to P.004
r.053	Speed Detection Hysteresis Band	Tunable	5 RPM (Vector) 1.0 Hz (V/Hz)	1 RPM 0.1 Hz	0 to 500 RPM 0 to 10.0 Hz
r.056	Low Speed Detection Level	Tunable	150 RPM (Vector) 5.0 Hz (V/Hz)	1 RPM 0.1 Hz	0 RPM to P.004 0.5 Hz to P.004
r.057	Current Detection Level 1	Tunable	100%	1%	0 to 150%
r.058	Current Detection Level 2	Tunable	100%	1%	0 to 150%
r.059	Current Detection Level 3	Tunable	100%	1%	0 to 150%
r.060	Current Detection Hysteresis	Tunable	0%	1%	0 to 10%
r.063	Torque Detection Level 1	Tunable	100%	1%	0 to 200%
r.064	Torque Detection Level 2	Tunable	100%	1%	0 to 200%
r.065	Torque Detection Level 3	Tunable	100%	1%	0 to 200%
r.066	Torque Detection Hysteresis	Tunable	0%	1%	0 to 10%

Parameters r.050 to r.066 define the levels at which the digital outputs are turned off and on. Parameter P.004 is used to set the maximum speed.

4.2 Selecting the RMI Board as the Trim Reference Source

The RMI inputs are selected as the source for trim reference using parameter P.014 (Trim Reference Source). See figure 4.4. For more information about P.014, see the drive software instruction manual.

Troubleshooting Guidelines

The drive displays fault codes to signal a problem in the RMI board during self tuning (start up) or drive operation. If a fault occurs, the outputs will be turned off and the drive will coast to a stop. The fault code will flash on the drive's display as a three-digit alpha-numeric code.

Note that the option to hold last reference is not supported with the RMI board. Parameter P.062 (Option Port: Communication Loss Response) does not apply.

5.1 Fault Codes

Table 5.1 lists fault codes associated with the RMI board. For a complete list of drive fault codes and for details on troubleshooting using fault codes, see the drive software instruction manual.

Table 5.1 – RMI Fault Codes

Code	Fault Description	Fault Cause	Corrective Action
F60	Option port identification error	On power up, the Regulator board did not identify the RMI board. This can be due to: <ul style="list-style-type: none"> • a communication problem over the ribbon cable • a bad RMI board • bad Regulator board 	Check the ribbon cable between the Regulator board and the RMI board. Replace the RMI board or the Regulator board if necessary.
F61	Option board power-up diagnostic failure	On power up, the ROM check sum diagnostic failed on the RMI board	Check the ribbon cable between the Regulator board and the RMI board. Replace the RMI board if necessary.
F62	Option board runtime error	During operation, the RMI watchdog failed, or handshaking with the drive failed.	Check the ribbon cable between the Regulator board and the RMI board. If intermittent, check for causes of noise, proper grounding, and that outputs are not exceeding rated current capacities Verify that the digital outputs are not drawing more than rated current (see appendix A). Replace the RMI board or Regulator board if necessary.

Technical Specifications

Isolated Digital Inputs		
	Number	4
	Features	Active high, programmable, overvoltage-protected.
	Range:	4 mA, 24 VDC
	Sample time:	1.0ms; the regulator is updated if the input stays in the same state for 3.0 ms.
	Supply:	24 VDC (short circuit protected) is available from the RMI board. This supply must not be used for powering external circuits.
Isolated Analog Input		
	Number:	1
	Features:	10-bit resolution, overvoltage-protected, programmable, software-calibrated.
	Range:	0 to 10 VDC (jumper setting: V IN) 0(4) to 20 mA (jumper setting: C IN)
	Sample time:	1.0 ms
	Moving average:	4 scans
Isolated Frequency Input		
	Number:	1
	Features:	Software-scaled.
	Range:	0 to 200 kHz, 15 VDC
	Input Impedance:	2.64 k Ω , 2.2 nF
	Sample time:	5.0 to 20.0 ms in steps of 1.0 ms, or 20.0 to 500.0 ms in steps of 20.0 ms If sample time \leq 20.0 ms, scan time = 1.0 ms and moving average = scan time. Otherwise, scan time = sample time / 20, and moving average = sample time / 20

Isolated Digital Outputs		
	Number:	4
	Features:	Programmable, source-driven (active high with common ground) and short circuit-protected.
	Range:	24 VDC, 20 mA per output (jumper setting: 24 V INT) 100 mA per output with external power supply (jumper setting: 24 V EXT)
	Update time:	1.0 ms if delay time = 0 100.0 ms if delay time \neq 0
Relay Outputs		
	Number:	3
	Features:	Three relays, programmable, timer function. Relay 1 has a normally-open contact. Relays 2 and 3 have 1 normally-open and 1 normally-closed contact.
	Rating:	2 A, 24VDC or 250VA, 120VAC
	Update time:	1.0 ms if delay time = 0 100.0 ms if delay time \neq 0
Isolated Analog Outputs		
	Number:	3
	Features:	Short circuit-protected, programmable, software-calibrated.
	Range:	Output 1: 0 to 10 VDC Output 2: -0 to +10VDC Output 3: 0 to 10 VDC (jumper setting: V OUT) 0 to 20 mA (jumper setting: C OUT)
	Load:	10 VDC outputs: $R_L \geq 10 \text{ k}\Omega$ 20 mA output: $R_L \leq 500\Omega$
	Crossover frequency:	1 kHz
	Carrier frequency:	20 kHz
	Resolution:	10 bits
Connection Port to the Regulator Board		
	34-pin flat cable connector	
Power Consumption of the RMI Board		
	24 V supply current:	Max. 320 mA with unloaded digital outputs
	Additional load:	Max. 20mA load current per digital output (4 total)
	External 24 V supply:	For 20 mA < load current < 100 mA, an external 24 V power supply must be connected to terminals 46 (+) and 51 (-) and the 24V jumper must be set to 24 V EXT.
	15 V	Not used.

APPENDIX B

Alphabetical Listing of RMI Parameters

Parameter Name	Parameter Number
Analog Input Gain	r.011
Analog Input Offset	r.010
Analog Output 1 Gain	r.003
Analog Output 1 Offset	r.002
Analog Output 1 Source	r.001
Analog Output 2 Gain	r.006
Analog Output 2 Offset	r.005
Analog Output 2 Source	r.004
Analog Output 3 Gain	r.009
Analog Output 3 Offset	r.008
Analog Output 3 Source	r.007
Current Detection Hysteresis	r.060
Current Detection Level 1	r.057
Current Detection Level 2	r.058
Current Detection Level 3	r.059
Digital Input Configuration	r.030
Digital Output 1 Delay Time	r.040
Digital Output 1 Configuration	r.031
Digital Output 2 Configuration	r.032
Digital Output 2 Delay Time	r.041
Digital Output 3 Configuration	r.033
Digital Output 3 Delay Time	r.042
Digital Output 4 Configuration	r.034
Digital Output 4 Delay Time	r.043
Frequency Input Gain	r.016
Frequency Input Offset	r.015
Frequency Input Sample Period	r.014
Low Speed Detection Level	r.056
PI Regulator Integral Gain	r.022

Parameter Name	Parameter Number
PI Regulator Offset	r.020
PI Regulator Proportional Gain	r.021
Relay Output 1 (NO) Configuration	r.035
Relay Output 1 Delay Time	r.044
Relay Output 2 (NC/NO) Configuration	r.036
Relay Output 2 Delay Time	r.045
Relay Output 3 (NO/NC) Configuration	r.037
Relay Output 3 Delay Time	r.046
Speed Detection Hysteresis Band	r.053
Speed Detection Level 1	r.050
Speed Detection Level 2	r.051
Speed Detection Level 3	r.052
Torque Detection Hysteresis	r.066
Torque Detection Level 1	r.063
Torque Detection Level 2	r.064
Torque Detection Level 3	r.065
Torque/Current Limit Source	r.025

1 to 20 HP @ 230 VAC drive installation, 3-12
 1 to 5 HP @ 460 VAC drive installation, 3-4
 100 to 150 HP @ 460 VAC drive installation, 3-26
 15 to 25 HP @ 460 VAC drive installation, 3-21
 2 to 43 amp Bookshelf drive installation, 3-34
 200 to 400 HP @ 460 VAC drive installation, 3-31
 25 to 60 HP @ 460 VAC drive installation, 3-21
 30 to 100 HP @ 230 VAC drive installation, 3-16
 50 to 100 HP @ 460 VAC drive installation, 3-26
 7.5 to 10 HP @ 460 VAC drive installation, 3-8
 75 to 200 @ 460 VAC drive installation, 3-16

A

analog input, 2-3
 programming, 4-3
 specifications, A-1
 Analog Input Gain (r.011), 4-3
 Analog Input Offset (r.010), 4-3
 Analog Output 1 Gain (r.003), 4-2
 Analog Output 1 Offset (r.002), 4-2
 Analog Output 1 Source (r.001), 4-2
 Analog Output 2 Gain (r.006), 4-2
 Analog Output 2 Offset (r.005), 4-2
 Analog Output 2 Source (r.004), 4-2
 Analog Output 3 Gain (r.009), 4-2
 Analog Output 3 Offset (r.008), 4-2
 Analog Output 3 Source (r.007), 4-2
 analog outputs, 2-3
 programming, 4-2
 specifications, A-2

C

configuration
 digital output, 4-10
 relay outputs, 4-10
 connections, RMI terminal strip, 3-41
 Current Detection Hysteresis (r.060), 4-15
 Current Detection Level 1 (r.057), 4-15
 Current Detection Level 2 (r.058), 4-15
 Current Detection Level 3 (r.059), 4-15

D

DC bus
 voltage measuring points
 100 to 150 HP @ 460 VAC drives, 3-29
 voltage terminals
 1 to 20 HP @ 230 VAC drives, 3-13
 1 to 5 HP @ 460 VAC drives, 3-5
 15 to 25 HP @ 460 VAC drives, 3-22
 2 to 15 amp Bookshelf drives, 3-37
 24 to 30 amp Bookshelf drives, 3-38
 25 to 60 HP @ 460 VAC drives, 3-22
 43 amp Bookshelf drives, 3-39
 60 to 100 HP @ 460 VAC drives, 3-28
 7.5 to 10 HP @ 460 VAC drives, 3-9
 75 to 100 HP @ 230 VAC drives (VTAC 7 only), 3-17
 75 to 150 HP @ 460 VAC drives (VTAC 7 only), 3-17
 Digital Input Configuration (r.030), 4-6
 digital inputs, 2-2
 programming, 4-4, 4-6
 specifications, A-1
 Digital Output 1 Configuration (r.031), 4-10
 Digital Output 1 Delay Time (r.040), 4-14
 Digital Output 2 Configuration (r.032), 4-10
 Digital Output 2 Delay Time (r.041), 4-14
 Digital Output 3 Configuration (r.033), 4-10
 Digital Output 3 Delay Time (r.042), 4-14
 Digital Output 4 Configuration (r.034), 4-10
 Digital Output 4 Delay Time (r.043), 4-14
 digital outputs, 2-2
 comparison, 4-15
 configuration, 4-10
 specifications, A-2
 timers, programming, 4-14

E

electrical description, RMI board, 2-1

F

F60 (fault code), 5-1
 F61 (fault code), 5-1
 F62 (fault code), 5-1
 frequency input, 2-3
 programming, 4-3
 specifications, A-1
 Frequency Input Gain (r.016), 4-3
 Frequency Input Offset (r.015), 4-3
 Frequency Input Sample Period (r.014), 4-3

G

GV3000/SE drive
hardware, 1-1
software, 1-1

H

hardware (GV3000/SE and VTAC 7 drives), 1-1

I

inputs

analog, 2-3
digital, 2-2
frequency, 2-3

installation, 3-1

1 to 20 HP @ 230 VAC drives, 3-12
1 to 5 HP @ 460 VAC drives, 3-4
100 to 150 HP @ 460 VAC drives, 3-26
15 to 25 HP @ 460 VAC drives, 3-21
2 to 43 amp Bookshelf drives, 3-34
200 to 400 HP @ 460 VAC drives, 3-31
25 to 60 HP @ 460 VAC drives, 3-21
30 to 100 HP @ 230 VAC drives, 3-16
50 to 100 HP @ 460 VAC drives, 3-26
60 to 100 HP @ 460 VAC drives, 3-26
7.5 to 10 HP @ 460 VAC drives, 3-8
75 to 200 @ 460 VAC drives, 3-16

J

jumpers (RMI board)

factory default settings, 2-1
location, 2-1

L

LED, status indicator, 2-1
Low Speed Detection Level (r.056), 4-15

M

mechanical description, RMI board, 2-1

O

Outer Loop PI Regulator, programming, 4-4

outputs

analog, 2-3
digital, 2-2
relay, 2-3

P

parameters

descriptions, 4-1
menu structure, 4-1
r, 4-1 to 4-15
alphabetic list, B-1
recording settings, 4-1
second menu, 4-1

PI Regulator Integral Gain (r.022), 4-4

PI Regulator Offset (r.020), 4-4

PI regulator operating modes, 4-4

PI Regulator Proportional Gain (r.021), 4-4

power consumption, A-2

programming reference, 4-1

R

r parameters, 4-1 to 4-15

alphabetic list, B-1

Relay Output 1 (NO) Configuration (r.035), 4-10

Relay Output 1 Delay Time (r.044), 4-14

Relay Output 2 (NO/NC) Configuration (r.036), 4-10

Relay Output 2 Delay Time (r.045), 4-14

Relay Output 3 (NO/NC) Configuration (r.037), 4-10

Relay Output 3 Delay Time (r.046), 4-14

relay outputs, 2-3

configuration, 4-10

specifications, A-2

timers, programming, 4-14

RMI board, mechanical/electrical description, 2-1

S

second menu parameters, 4-1

software (GV3000/SE and VTAC 7 drives), 1-1

specifications, A-1

Speed Detection Hysteresis Band (r.053), 4-15

Speed Detection Level 1 (r.050), 4-15

Speed Detection Level 2 (r.051), 4-15

Speed Detection Level 3 (r.052), 4-15

speed reference source, 4-7, 4-9

status LED, 2-1

T

technical specifications, A-1

terminal strip

connections, 3-41

signals, 2-2

timers, programming digital and relay output, 4-14

Torque Detection Hysteresis (r.066), 4-15

Torque Detection Level 1 (r.063), 4-15

Torque Detection Level 2 (r.064), 4-15

Torque Detection Level 3 (r.065), 4-15

Torque or Current Limit Selection (r.025), 4-5, 4-6

Torque/Current Limit Source (r.025), 4-5

trim reference source, RMI board as, 4-15

troubleshooting, 5-1

V

VTAC 7 drive hardware/software, 1-1

Documentation Improvement Form

Use this form to give us your comments concerning this publication or to report an error that you have found. For convenience, you may attach copies of the pages with your comments. After you have completed this form, please return it to:

Reliance Electric
Technical Documentation
24800 Tungsten Road
Cleveland, Ohio 44117

Fax: 216.266.7785

Publication Name: Super Remote Meter Interface (RMI) Board	
Publication Number: D2-3341-2	Publication Date: September 2000

Comments: _____

Your Name:	Date:
Company Name:	Phone: ()
Address:	

Thank you for your comments.

Technical Writing Internal Use	
Date:	DIF Number:
Follow-Up Action:	

Reach us now at www.rockwellautomation.com

Wherever you need us, Rockwell Automation brings together leading brands in industrial automation including Allen-Bradley controls, Reliance Electric power transmission products, Dodge mechanical power transmission components, and Rockwell Software. Rockwell Automation's unique, flexible approach to helping customers achieve a competitive advantage is supported by thousands of authorized partners, distributors and system integrators around the world.

Americas Headquarters, 1201 South Second Street, Milwaukee, WI 53204, USA, Tel: (1) 414 382-2000, Fax: (1) 414 382 4444

European Headquarters SA/NV, avenue Hermann Debroux, 46, 1160 Brussels, Belgium, Tel: (32) 2 663 06 00, Fax: (32) 2 663 06 40

Asia Pacific Headquarters, 27/F Citicorp Centre, 18 Whitfield Road, Causeway Bay, Hong Kong, Tel: (852) 2887 4788, Fax: (852) 2508 1846

Reliance Electric Standard Drives Business, 24800 Tungsten Road, Cleveland, OH 44117, USA, Tel: (1) 888 374 8370, Fax: (216) 266 7095



**Rockwell
Automation**