

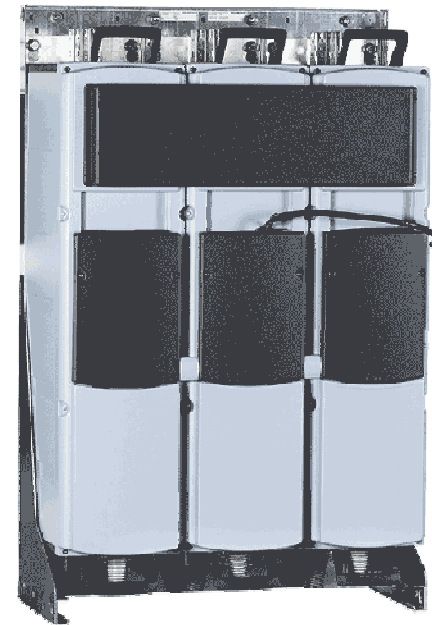

Turn to the Experts.™



Eaton LCX9000 Standard Tier VFD Training for Carrier Commercial Service

EATON LCX9000



Turn to the Experts.™

Overview

Literature

Drive identification

Component familiarization

Wiring Diagrams

Check field wiring and enter the control parameter before start up

Basic troubleshooting

Registering the new drive in the Rockwell Warp System

EATON LCX9000



Turn to the Experts.™

Literature & Wiring

19XRV-4SS Start Up and Operations Manual

19XRV-?SI Installation Manual

202-009004-001 Control Schematic w/o meter package

202-009004-002 Control Schematic w/ meter package



19XRV
with PIC III Controls
Eaton LCX9000 VFD Option

Start-Up and Service Instructions

SAFETY CONSIDERATIONS

<p>Centrifugal liquid chillers are designed to provide safe and reliable service when operated within design specifications. When operating this equipment, use good judgment and safety precautions to avoid damage to equipment and property or injury to personnel.</p> <p>Be sure you understand and follow the procedures and safety precautions contained in the chiller instructions as well as those listed in this guide.</p> <div style="background-color: black; color: white; text-align: center; padding: 2px;">⚠ DANGER</div> <p>ONLY QUALIFIED Electrical Personnel familiar with the construction and operation of this equipment and the hazards involved should install, adjust, operate, or service this equipment.</p> <p>READ AND UNDERSTAND this manual and other applicable manuals in their entirety before proceeding. Failure to observe this precaution could result in severe bodily injury or loss of life.</p> <p>DO NOT install modification kits with power applied to the drive. Disconnect and lock out incoming power before attempting such installation or removal. Failure to observe this precaution could result in severe bodily injury or loss of life.</p> <p>UNUSED WIRES in conduit must be grounded at both ends to avoid a possible shock hazard caused by induced voltages. Also, if a drive sharing a conduit is being serviced or installed, all drives using this conduit should be disabled to eliminate the possible shock hazard from cross-coupled</p>	<p>DO NOT WORK ON electrical components, including control panels, switches, VFD, or oil heater until you are sure ALL POWER IS OFF and no residual voltage can leak from capacitors or solid-state components.</p> <p>DO NOT perform any measurements when the drive is connected to the main power supply. Prior to measurements on the motor cable, disconnect the motor cable from the drive.</p> <p>LOCK OPEN AND TAG electrical circuits during servicing. IF WORK IS INTERRUPTED, confirm that all circuits are deenergized before resuming work.</p> <p>AVOID SPILLING liquid refrigerant on skin or getting it into the eyes. USE SAFETY GOGGLES. Wash any spills from the skin with soap and water. If liquid refrigerant enters the eyes, IMMEDIATELY FLUSH EYES with water and consult a physician.</p> <p>DO NOT ATTEMPT TO REMOVE flanges, covers, etc., while chiller is under pressure or while chiller is running. The max pressure is at 6 psig (0.4kPa) before breaking any refrigerant connection.</p> <div style="background-color: black; color: white; text-align: center; padding: 2px;">⚠ CAUTION</div> <p>TO AVOID an electric shock hazard, verify that the voltage on the bus capacitor has discharged completely before servicing. Check the DC bus voltage at the Power Terminal Block by measuring between the +DC and -DC terminals, between the +DC terminal and the chassis, and between the -DC terminal and the chassis. The voltage must be zero for all three measurements.</p>
--	--

EATON LCX9000



Turn to the Experts.™

Standard Work Instructions

CCS-SOP-7-SWI00418 Eaton LCX9000:How to generate service info with 9000XDrive

CCS-SOP-7-SWI00419 Eaton LCX9000:How to setup trend recorder using 9000XDrive

EATON LCX9000



Turn to the Experts.™

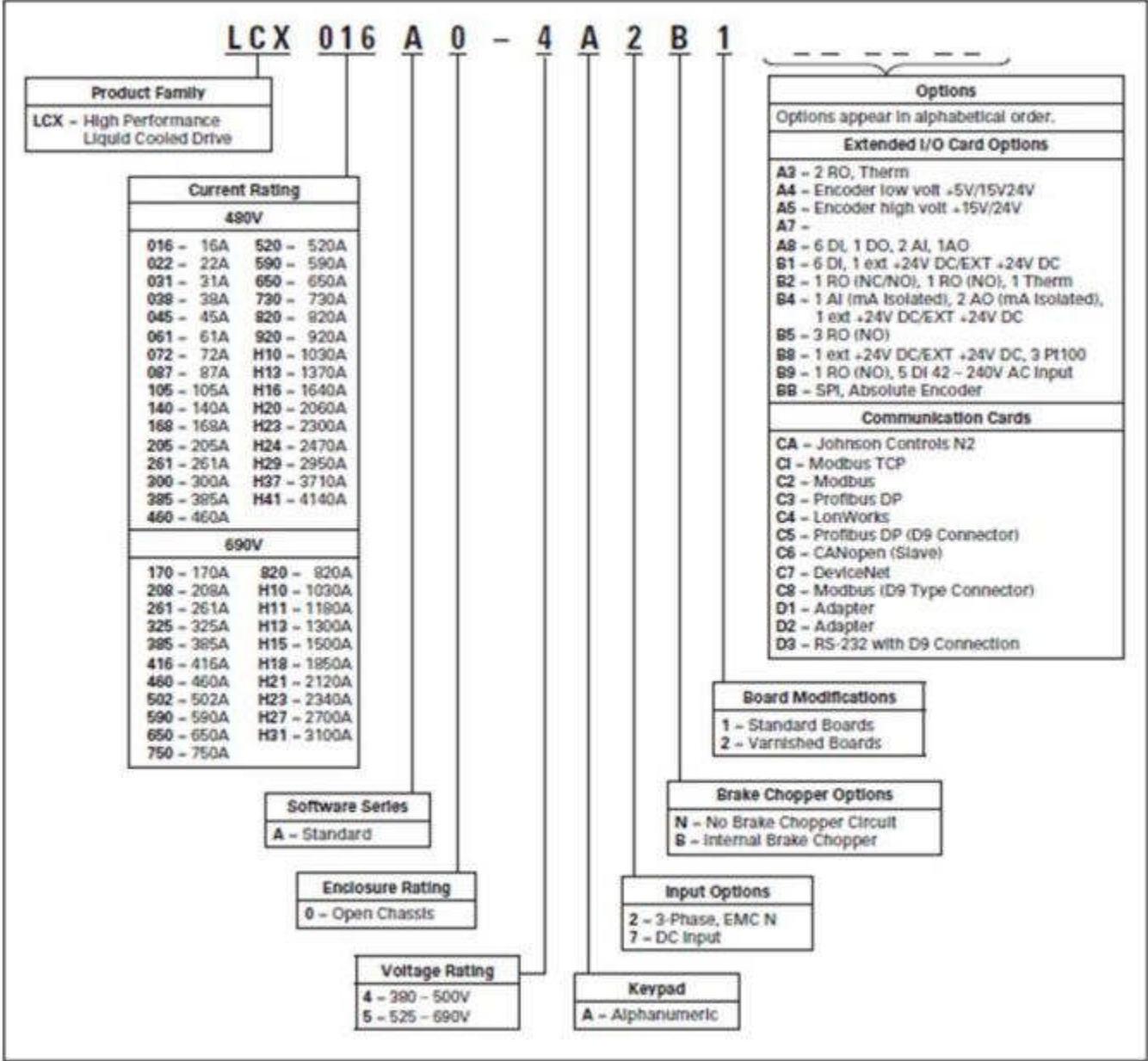

EATON LCX9000

Overview



CH72

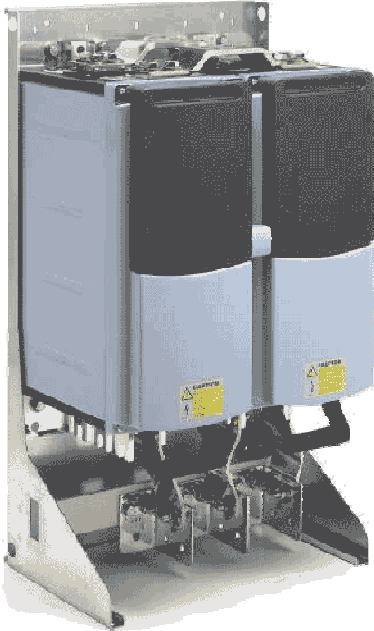

CH63



CH74

Three Frame Sizes for
Carrier Application

EATON LCX9000



Turn to the Experts.™

Table 1 — VFD Frame Size and Application

EATON FRAME SIZE	CARRIER PART NO.	MAXIMUM CONTINUOUS AMP RATING
CH72	19XVE0485	485
	19XVE0550	550
	19XVE0605	605
	19XVE0680	680
CH63	19XVE0765	765
	19XVE0855	855
	19XVE0960	960
	19XVE1070	1070
CH74	19XVE1275	1275
	19XVE1530	1530

EATON LCX9000

Frame CH72



Turn to the Experts™

Dimension: 9.69"W x 42.36"H x 14.65"D
 Weight: 198 lbs
 485-680 Amps



CH72

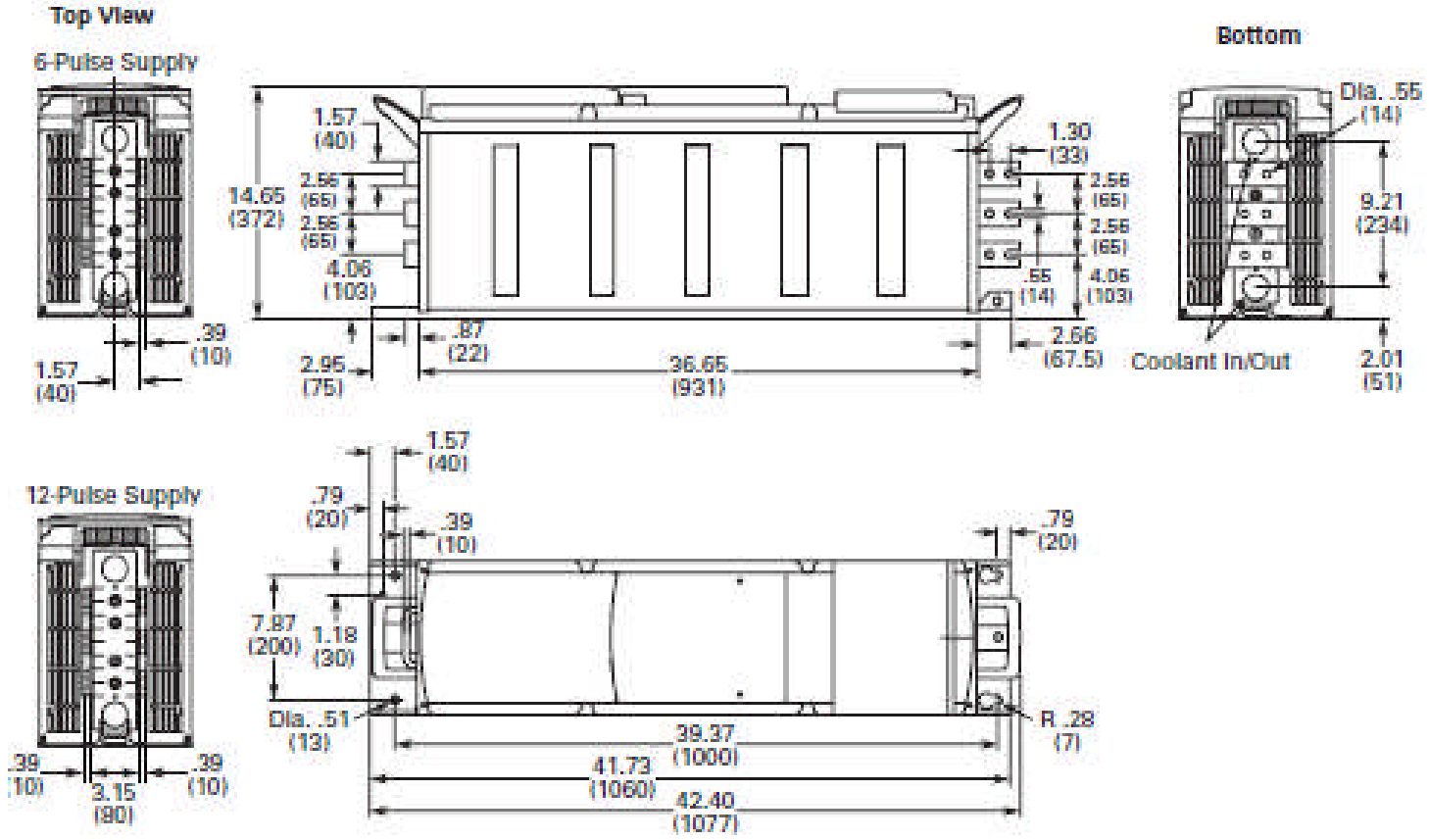

EATON LCX9000

CH72 Power Unit

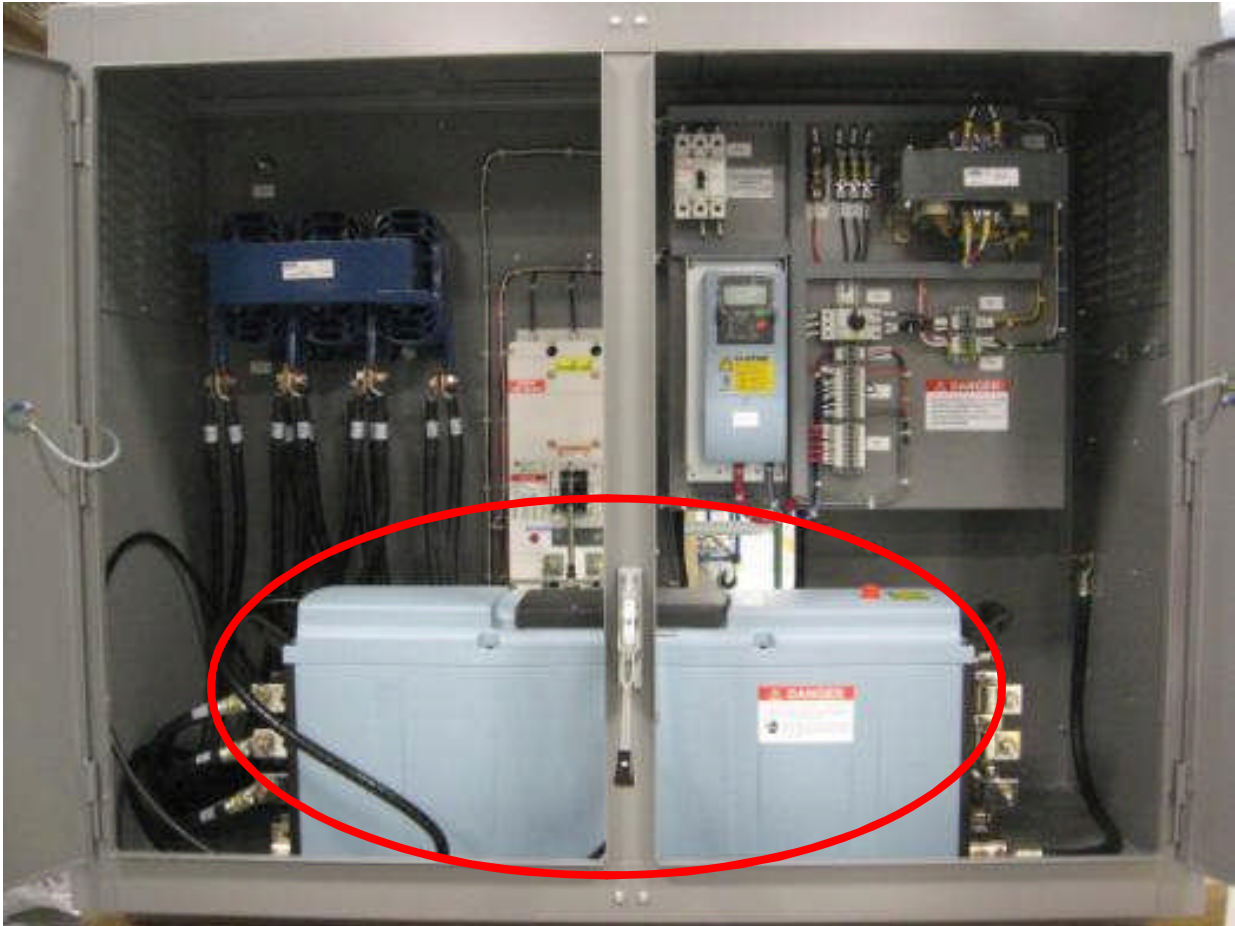

CH72 Power Unit Shown

EATON LCX9000

Frame CH63 Power Unit



Turn to the Experts.™

Eaton/Carrier VFD Package for the 19XRV Chiller

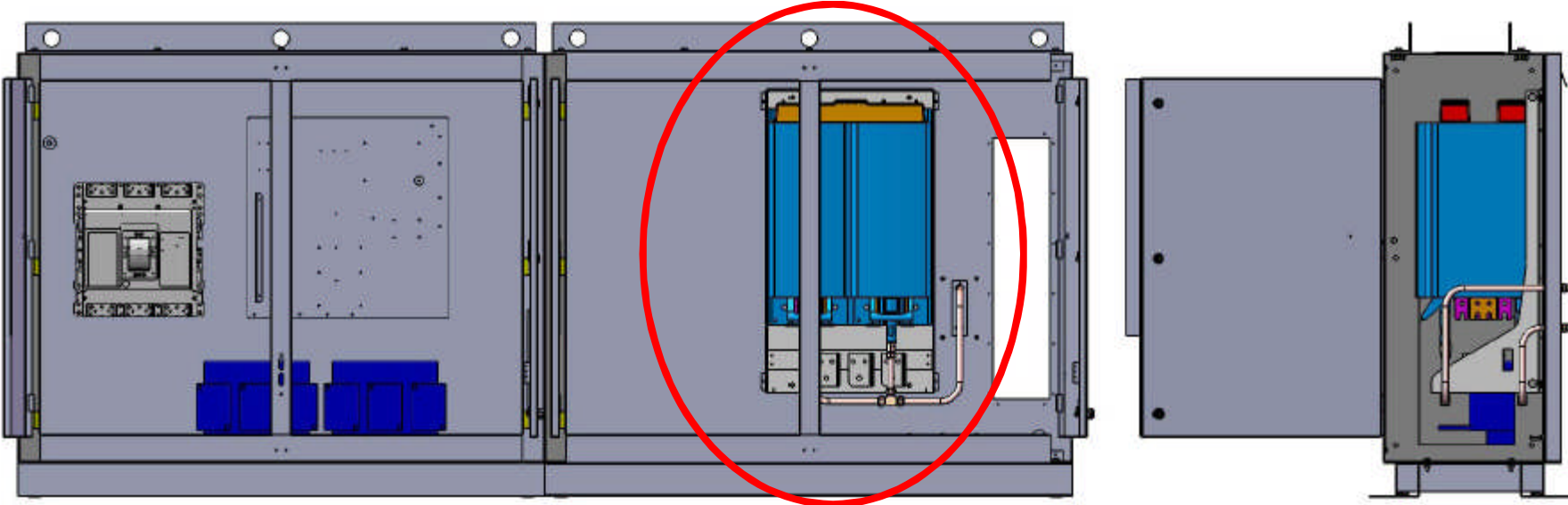

FRONT VIEW

RIGHT SIDE PANEL REMOVED

EATON LCX9000

Frame CH63



Turn to the Experts.™



CH63 Power Unit Shown

EATON LCX9000

Frame CH74

Dimension: 29.37"W x 46.26"H x 15.16"D

Weight: 617 lbs

1275-1530 Amps



Turn to the Experts™



CH74

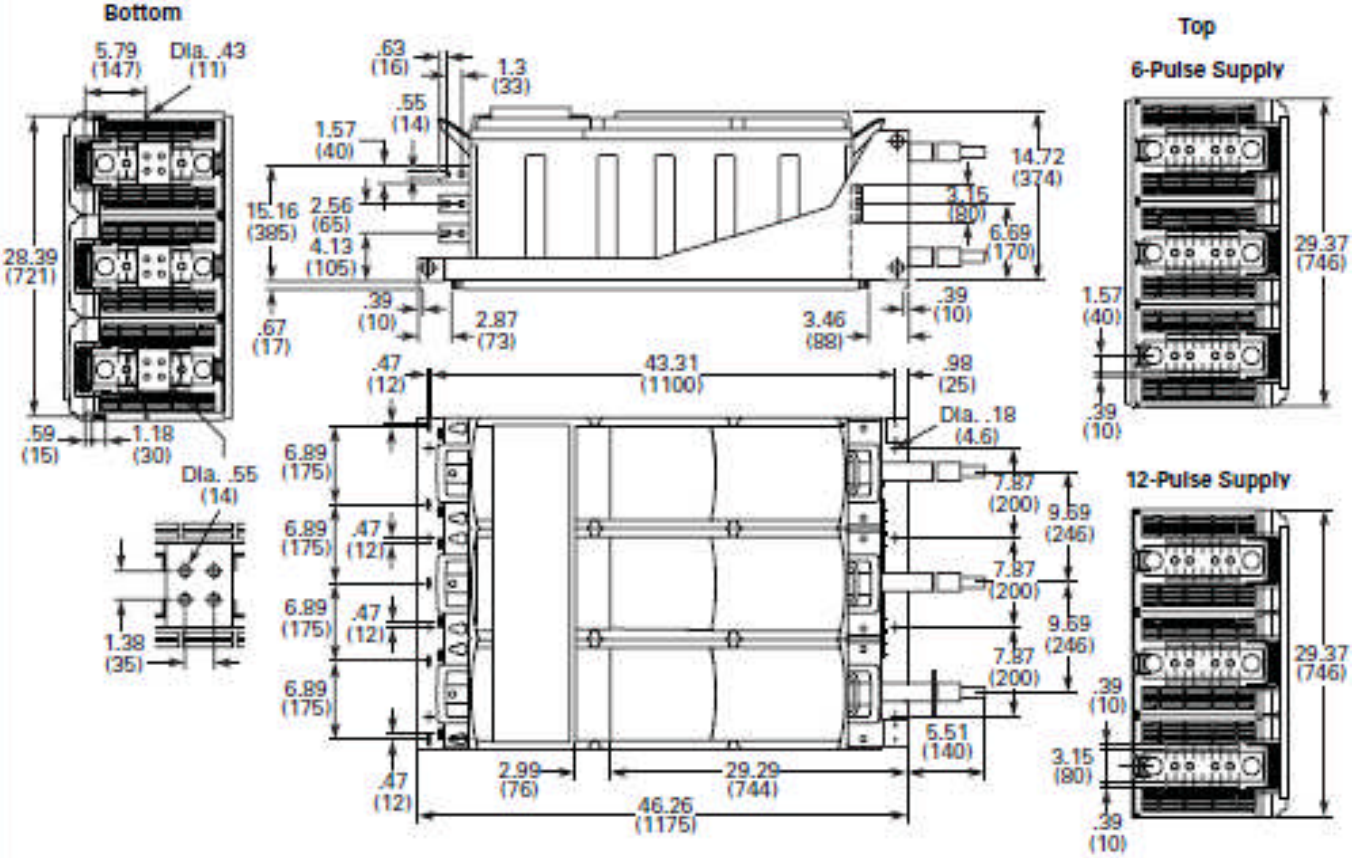

EATON LCX9000

Frame CH74 Power Unit



Turn to the Experts™

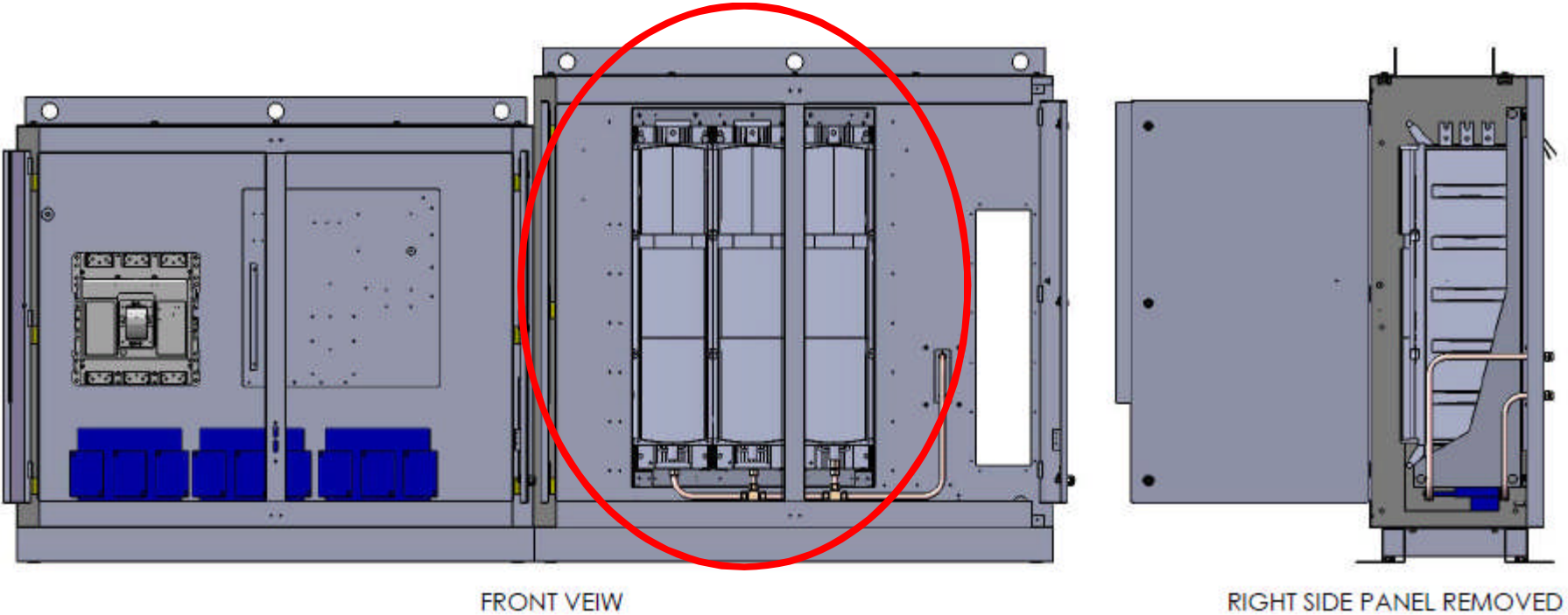

Eaton/Carrier VFD Package for the 19XRV Chiller

EATON LCX9000

Drive Layout



The unit has door interlocks to prevent opening the enclosure doors with the drive in operation



EATON LCX9000

Drive Layout

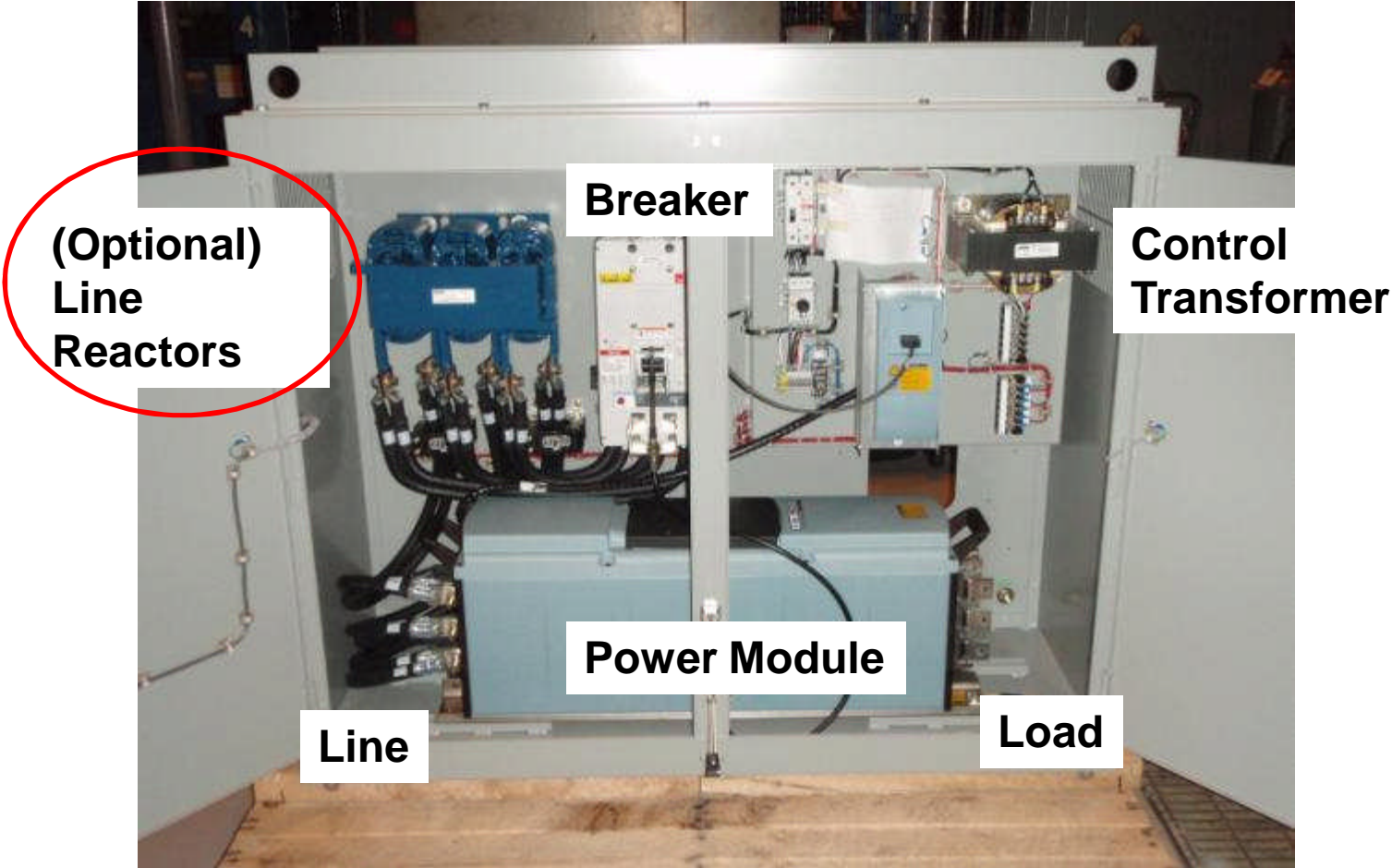

EATON LCX9000

Drive Layout



Turn to the Experts™

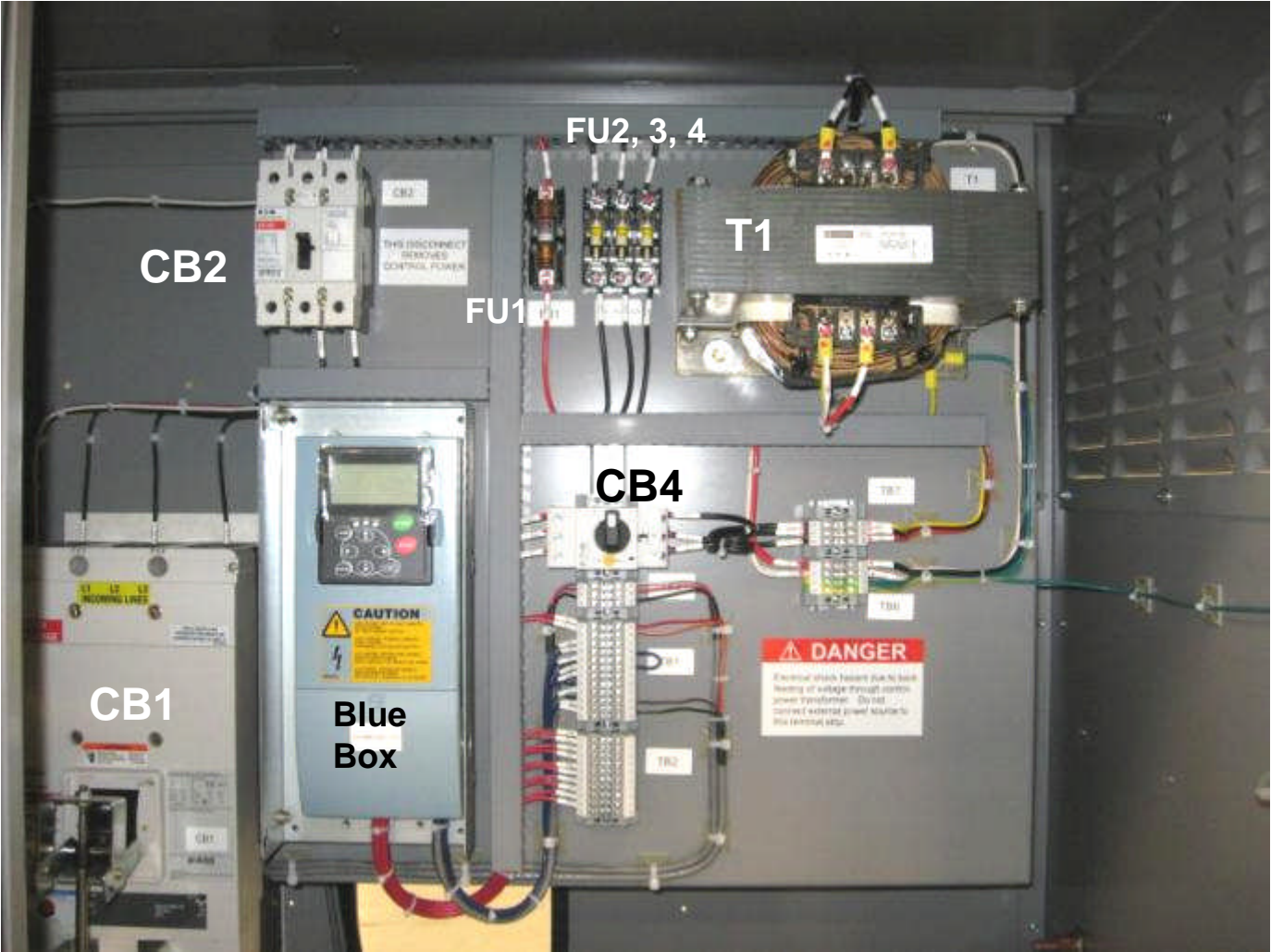

EATON LCX9000

Drive Layout: TB1 & TB2

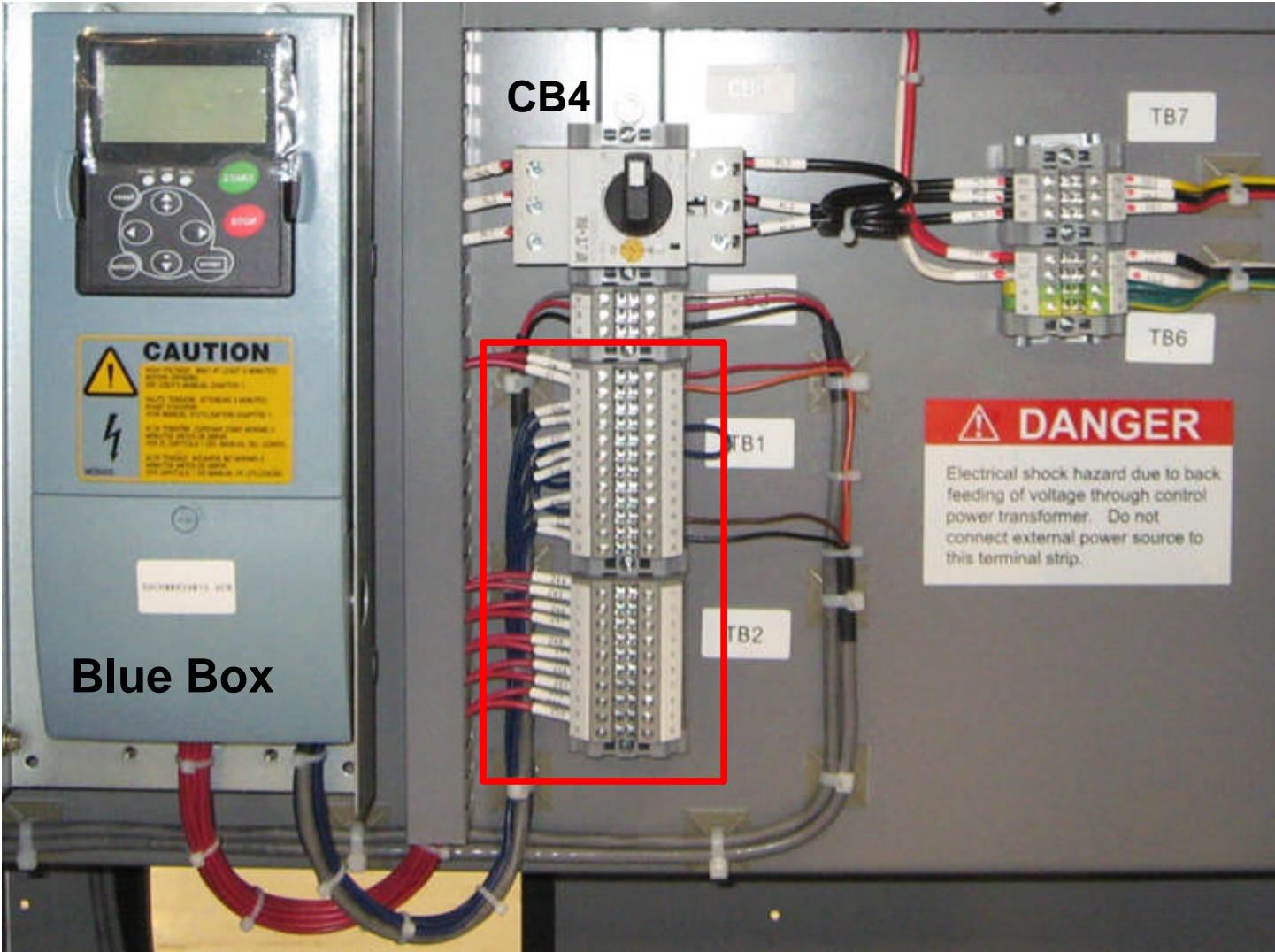

EATON LCX9000

Line Reactor Optional



Turn to the Experts™

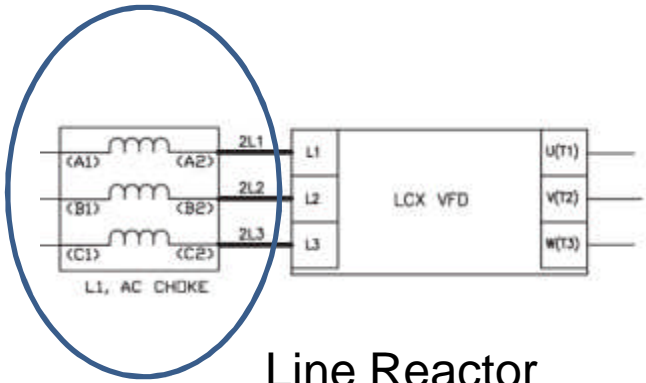

Line Reactor

Average 3% impedance

Reduces VFD Harmonics

Helps protect from line disturbances



EATON LCX9000

Refrigerant cooling

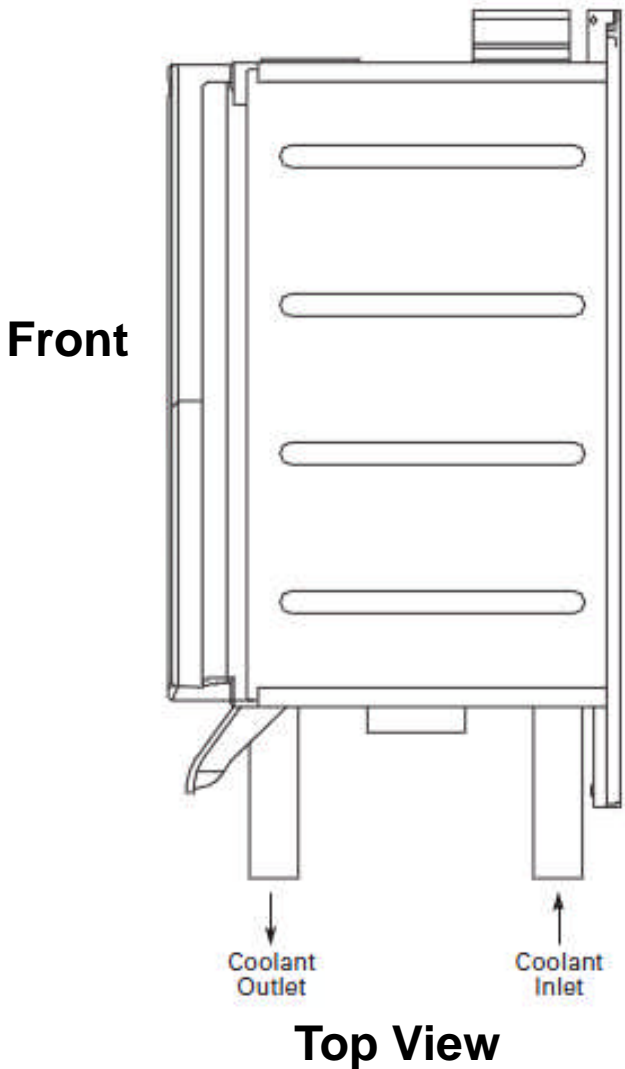

Overtemperature Alarm Protection

Heatsink 149°F

Circuit Boards 158°F

Ambient operating temperature 122°F (50°C).

Above 122°F-derating required

8 mins w/o refrigerant before tripping on overtemp

Outlet should not have condensation

No solenoid valve, it has been replaced with fixed orifice

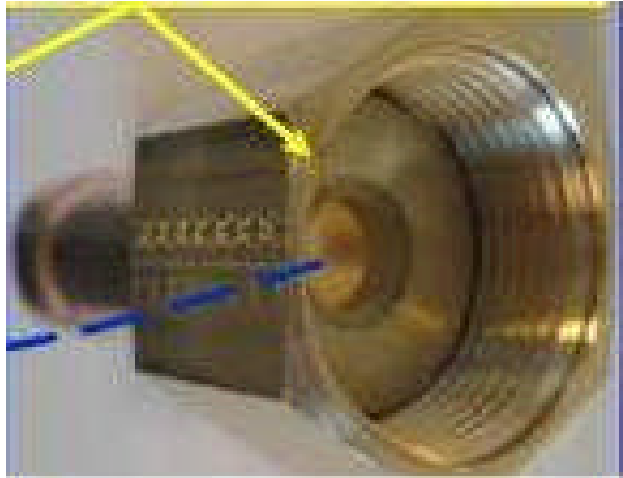

EATON LCX9000

Refrigerant cooling



Turn to the Experts.™



Refrigerant cooling lines entering and leaving the power module

*The temperature of the refrigerant line leaving the power module should not have condensation on it.



Turn to the Experts™

EATON LCX9000

Humidity Sensor

0-5 V Humidity Sensor Output
Wired to Terminals J5-6

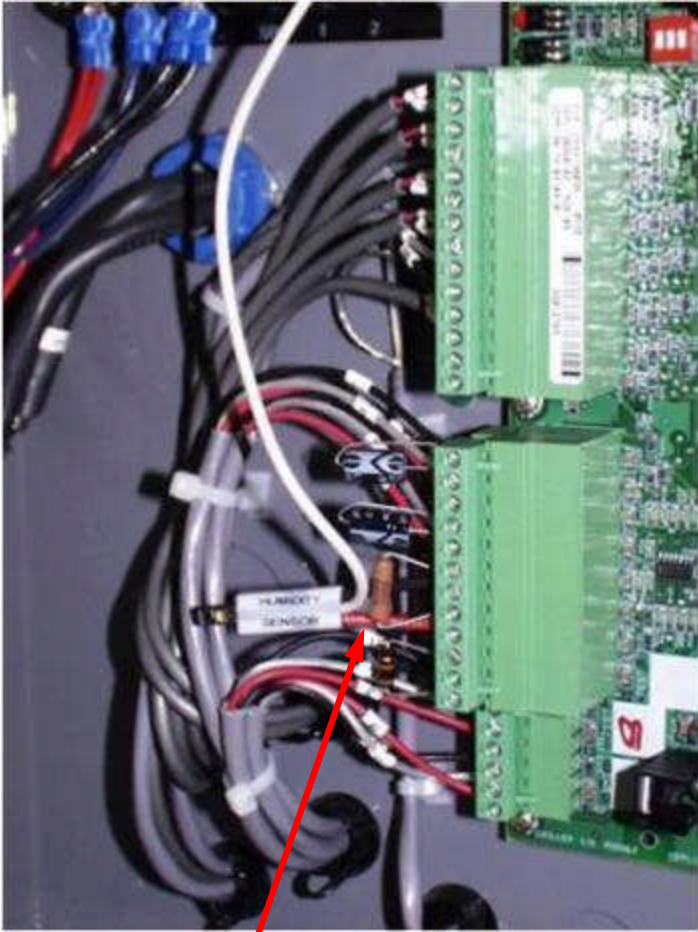
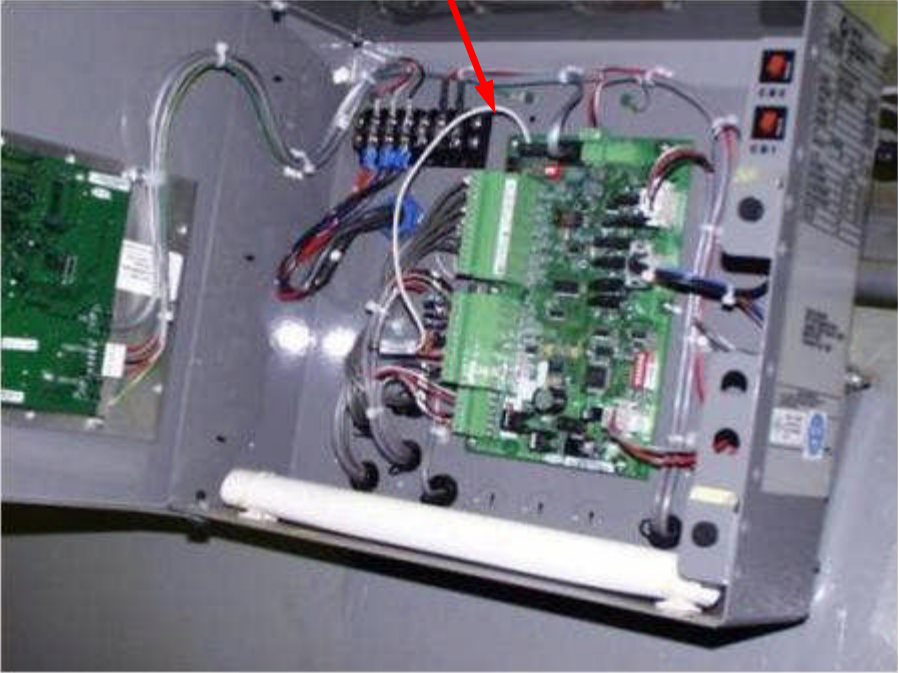

Terminals J3-7 and J3-9 Provide 5V
Power Supply to Humidity Sensor

EATON LCX9000



Turn to the Experts.™

Drive Components

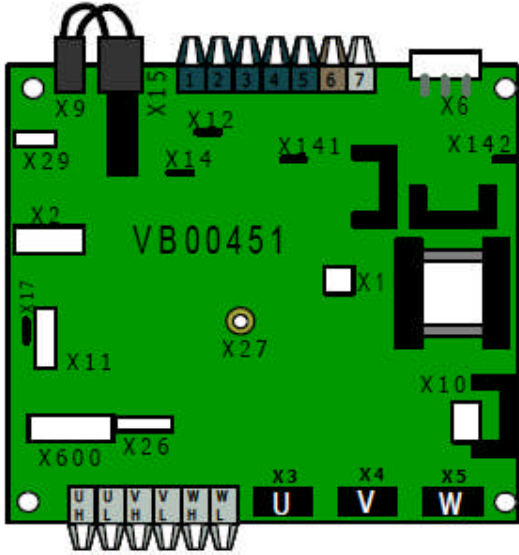
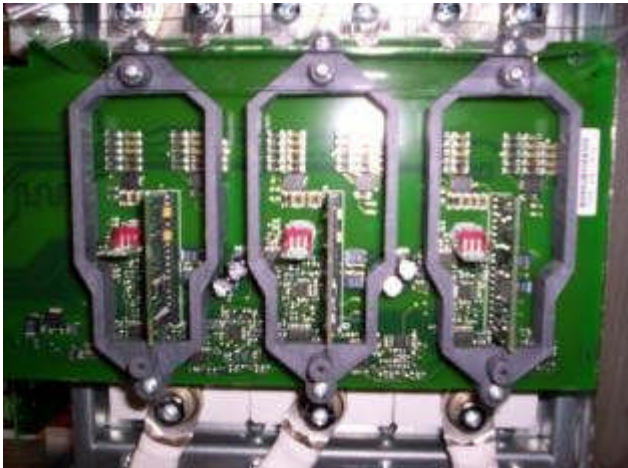

EATON LCX9000

Control module (Blue box)



LCX9000 Control is accomplished via the separately mounted Control Module

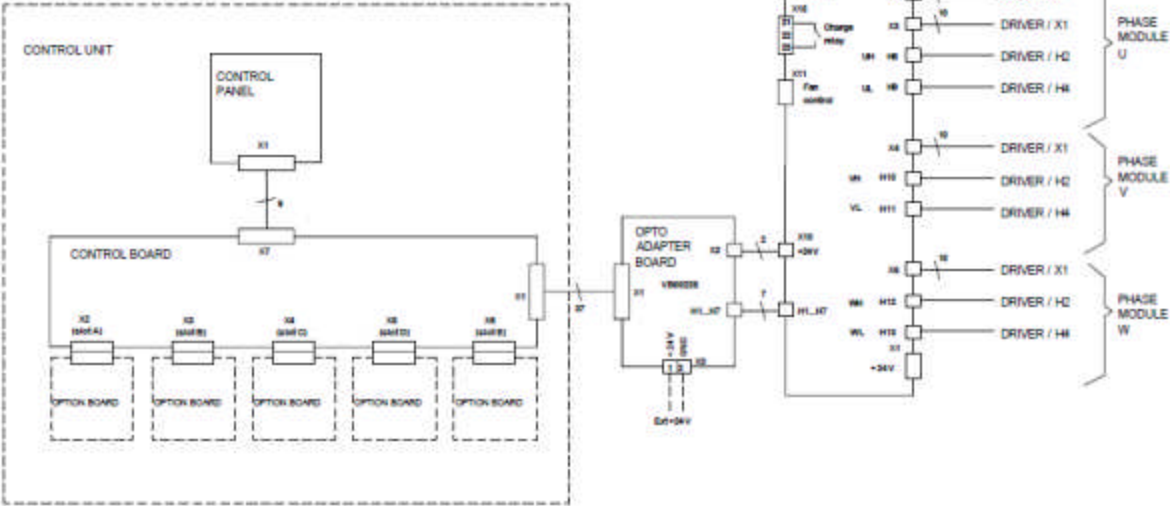

EATON LCX9000

Control Module



Carrier Standard – No Keypad

EATON LCX9000

Control Module

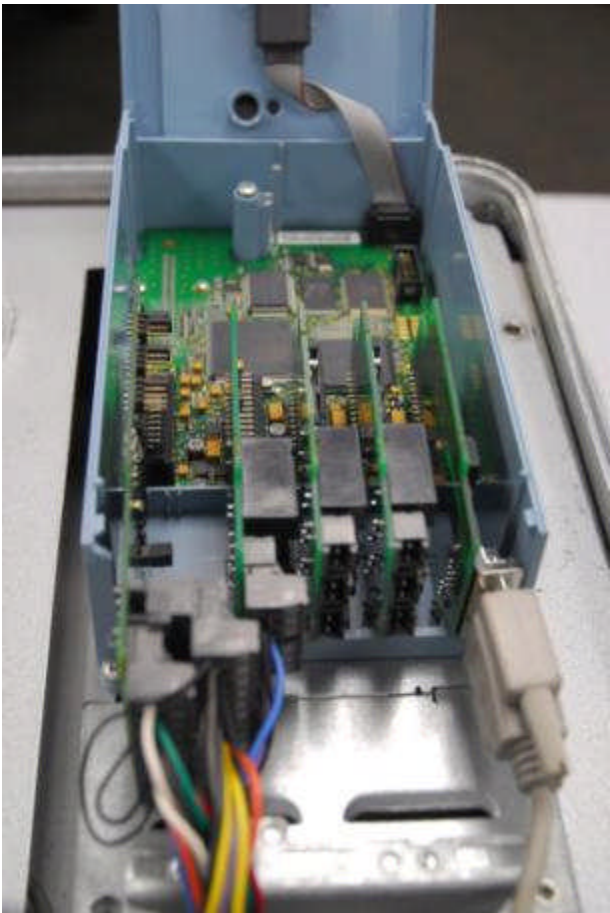



Turn to the Experts™

EATON LCX9000

Control Module

All LCX9000 Units use "SPX" version Control Module
5 Card Slots for are available for interfacing with Control Board.

Control Board

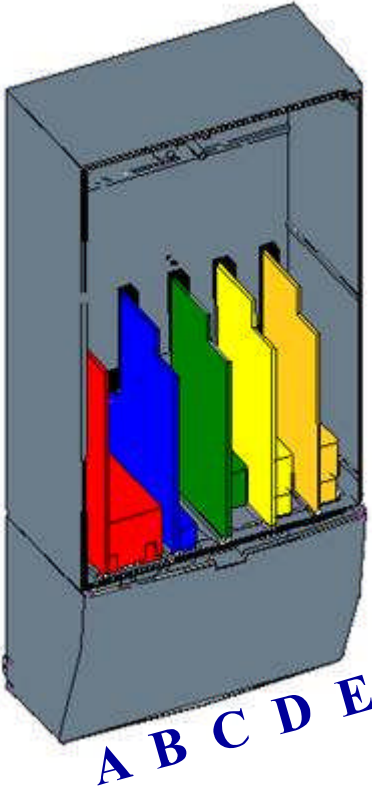

- Slots are designated A-E
- Slot A** = Basic I/O (OPTA9)
- Slot B** = Two form C relays (OPTA2)
- Slot C & D** =
Three N/O Relays each PCB (OPTB5)
- Slot E** = Communication PCB (OPTC2)

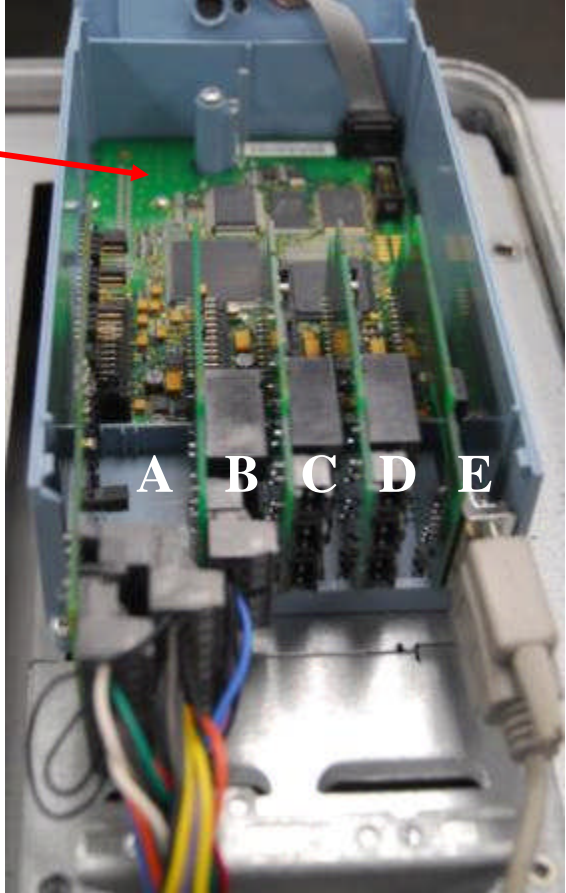

EATON LCX9000

Control Board

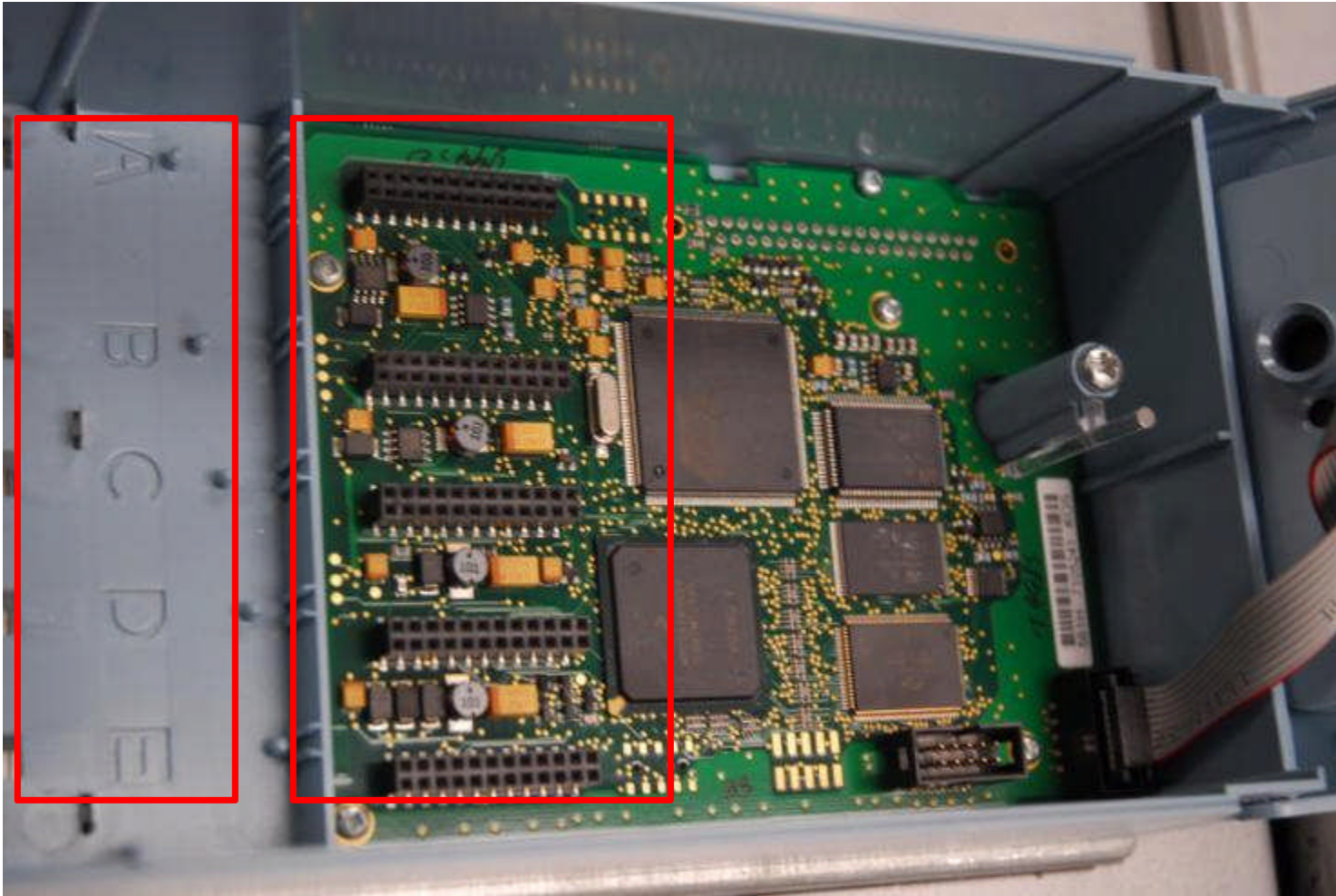

EATON LCX9000

Control Module: OPTA9

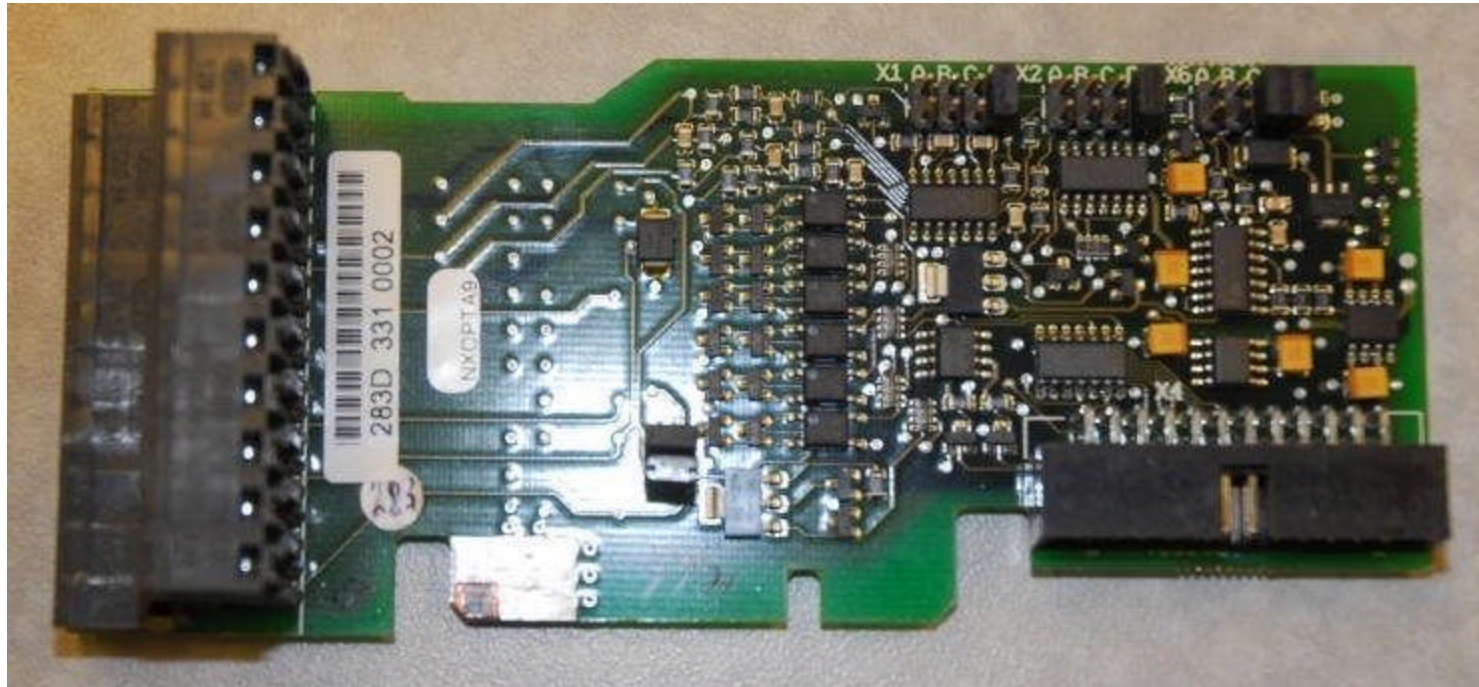

Slot A = Basic I/O (OPTA9)

Wired to:

Oil Interlock, 4-20ma Pressure Ref, Spare Safety, Ice Build, Remote Start, High pressure switch

EATON LCX9000

Control Module: OPTB5



Picture: Three N/O Relays each PCB (OPTB5)

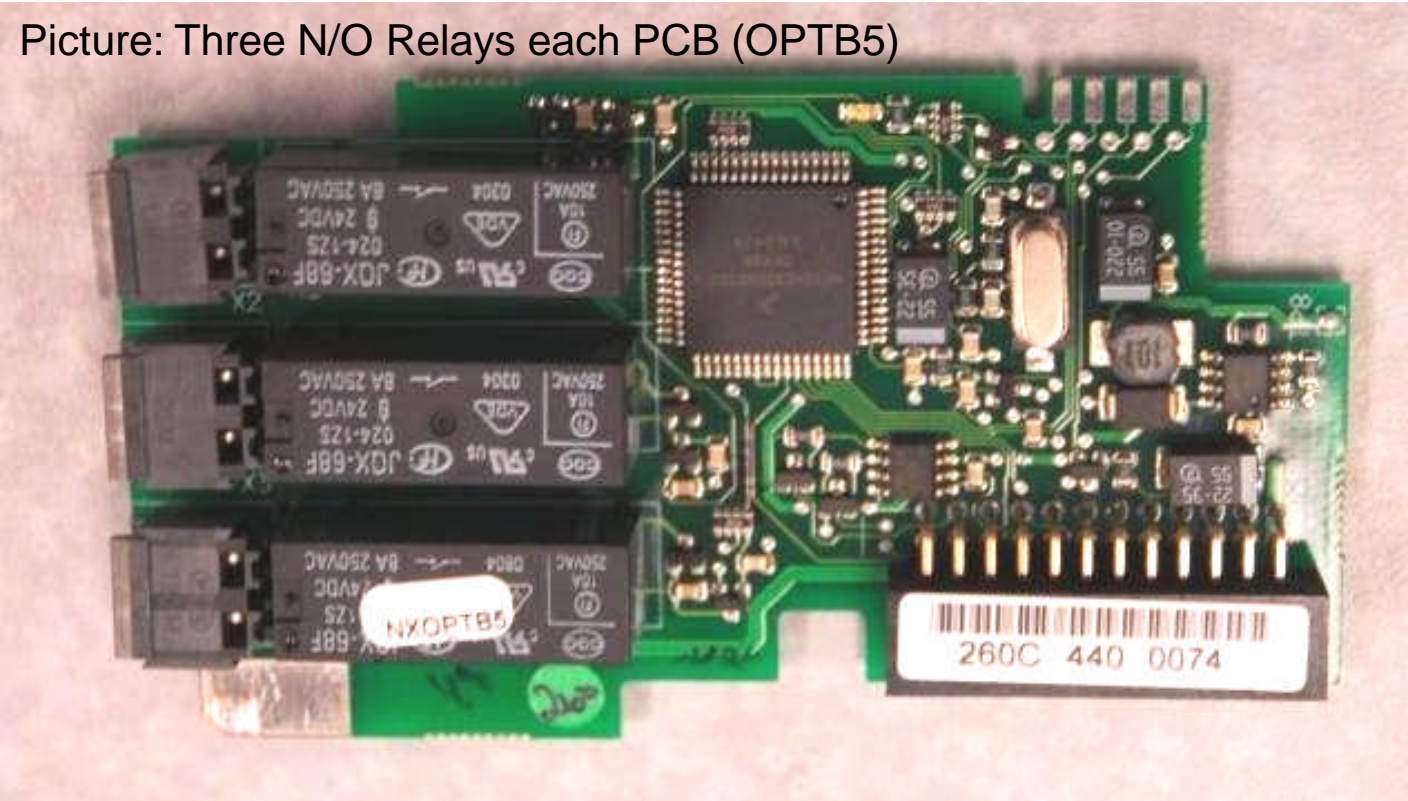

Slot B = Two form C relays (OPTA2)

Wired to : Shunt Trip

Slot C&D= Three N/O Relays each PCB (OPTB5)

Wired to: Evaporator Pump, Condenser Pump, Tower Fan Low, Tower Fan High, Trip Alarm

EATON LCX9000

Control Module: OPTC2

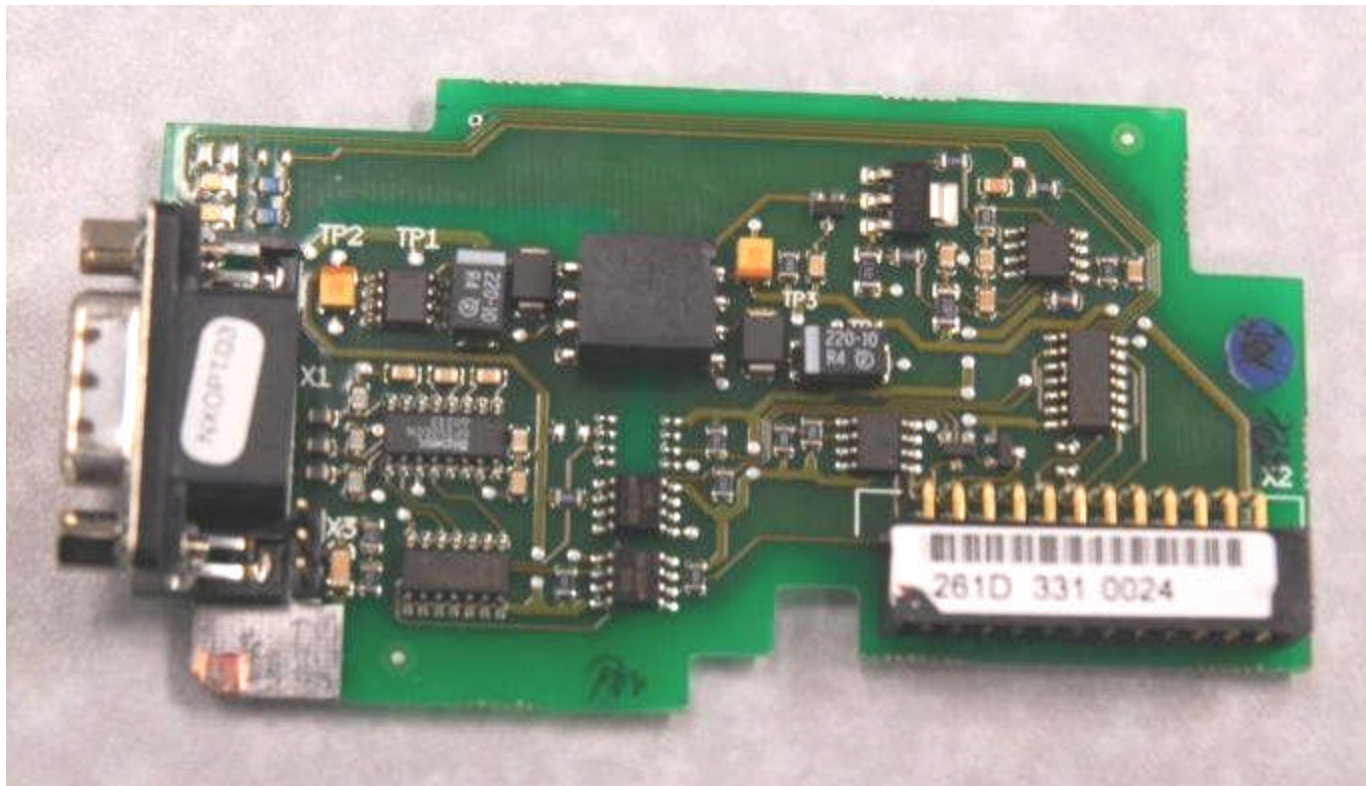

Slot E = Communication PCB (OPTC2)

Temporary power – 24VDC to 12 or 13(+ve) & 6 or 7(com)

EATON LCX9000

Side view CH72 drive

Turn to the Experts.™

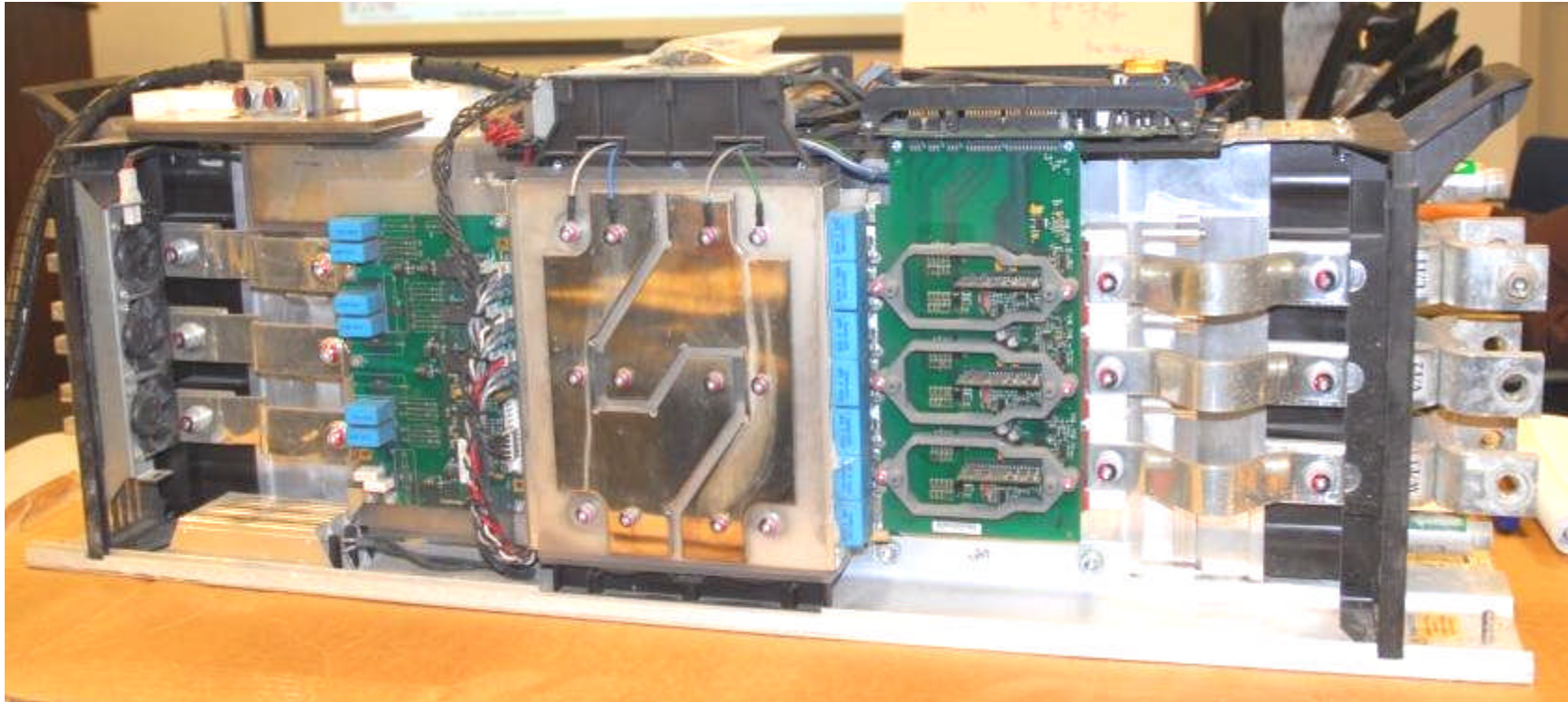

EATON LCX9000

Side view CH72 drive

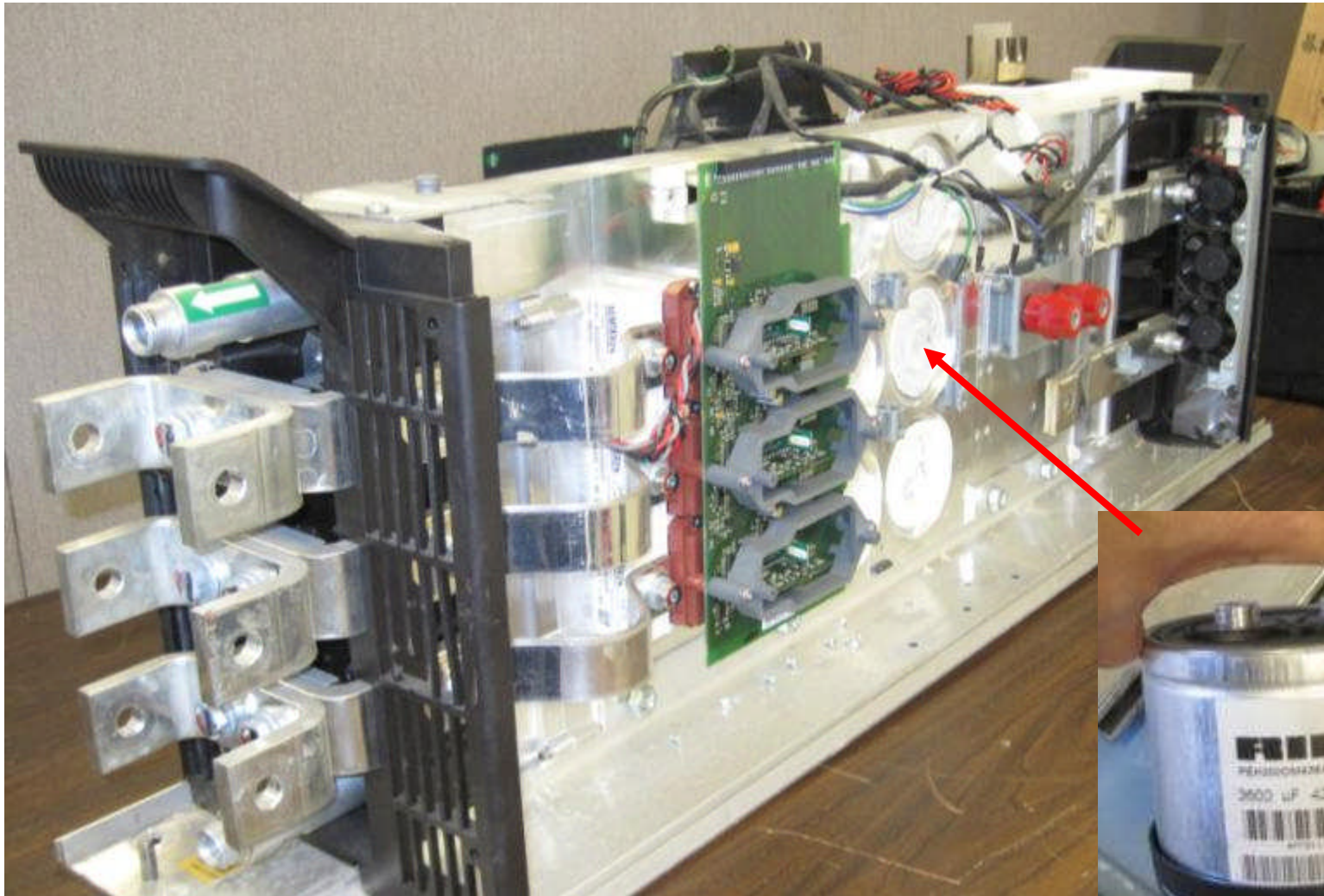

EATON LCX9000

Power Unit



Turn to the Experts.™



**DC Bus Voltage
HOT!!!**

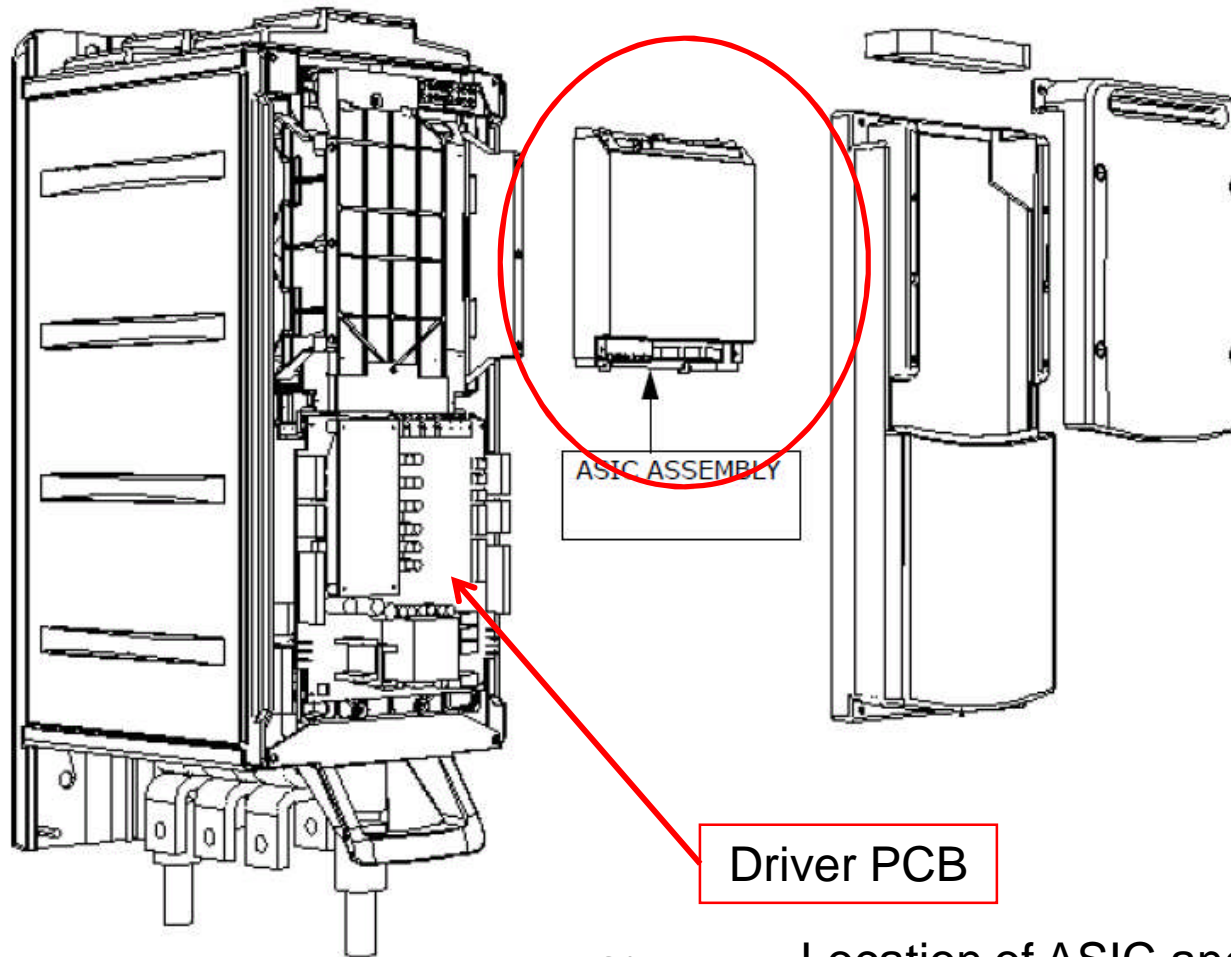

EATON LCX9000

Asic Board



Turn to the Experts™

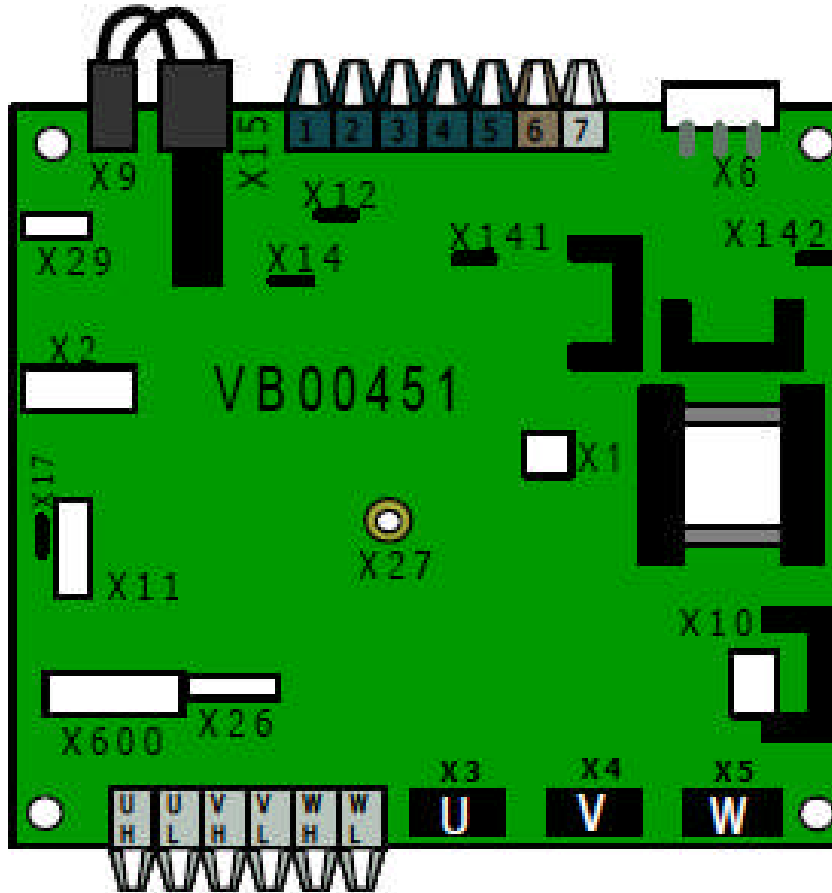

ASIC Board Function

DANGER!!! DC VOLTAGES

Brains of operation (talks to driver board)

Receives Signal from Logic module

Provide Gate drive signal

Turns drive cooling fans on

Provides 24 VDC to logic module

Send signal back to control module regarding temperature, voltage, amps, etc.

EATON LCX9000

Asic Assembly: HIGH VOLTAGE



Turn to the Experts.™

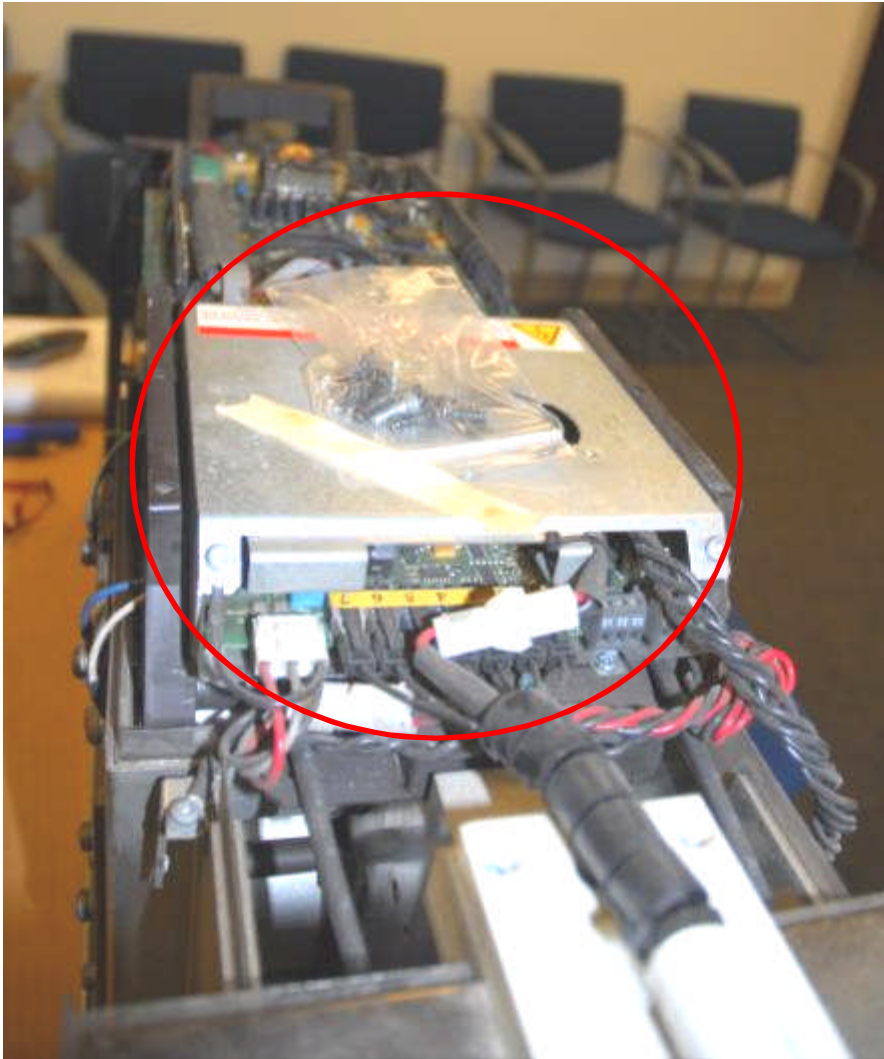

EATON LCX9000

ASIC Assembly

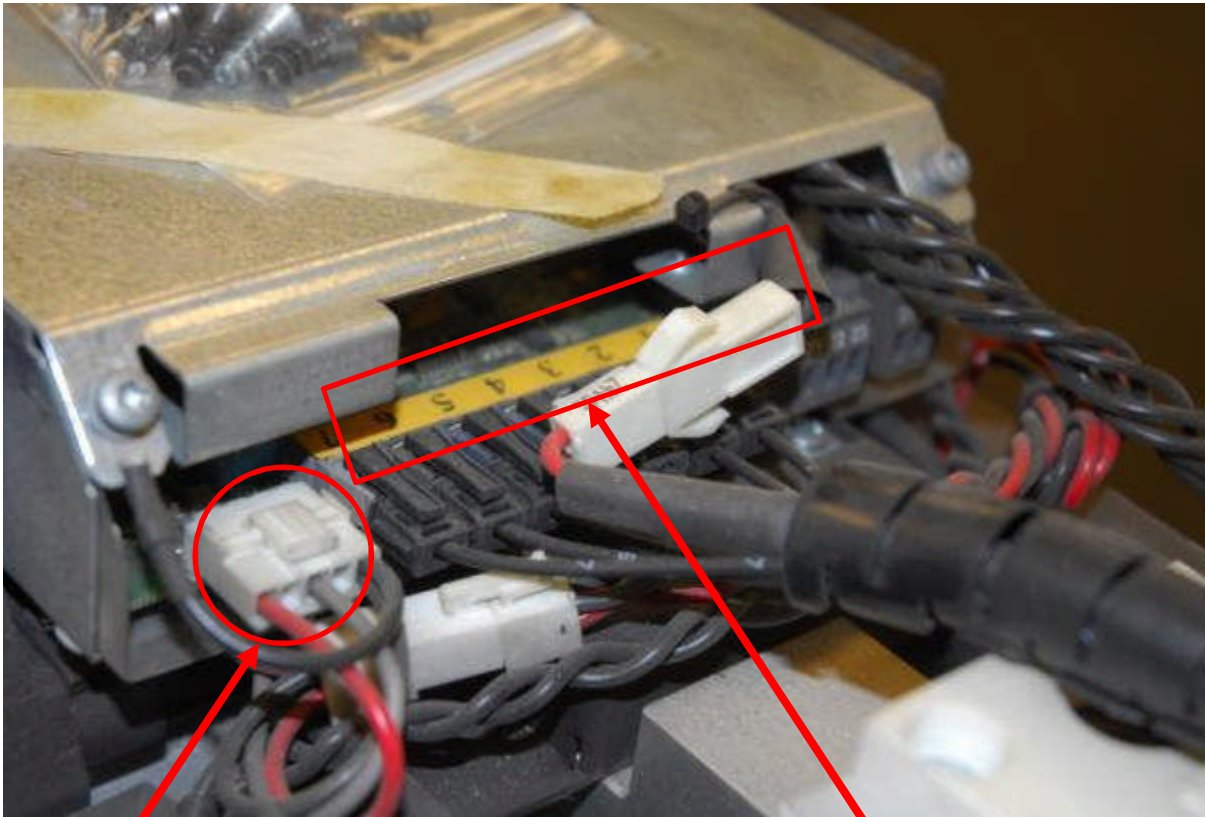

DC+ & DC-

Optical Fiber Cable

EATON LCX9000

Driver (PCB) Power Control Board



Turn to the Experts.™

Driver PCB Function

Talks to ASIC board

Connected to IGBT assembly & measurement boards

Takes signal and sends +/- 15V gates signal

Provide feedback for temp sensors and current

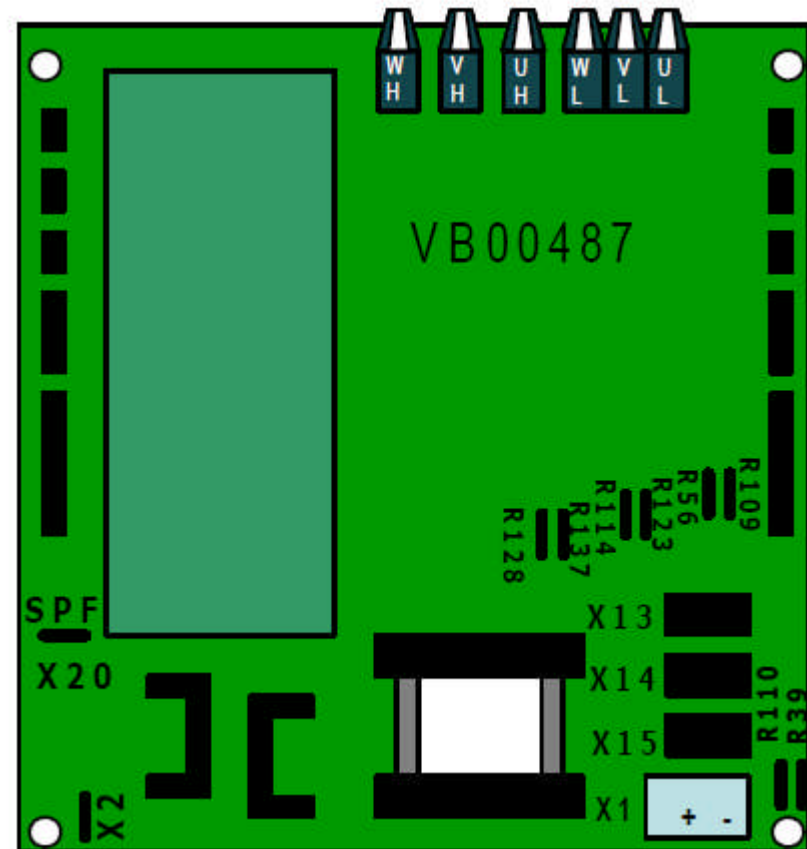

EATON LCX9000

Driver (PCB) Power Control Board



Turn to the Experts.™

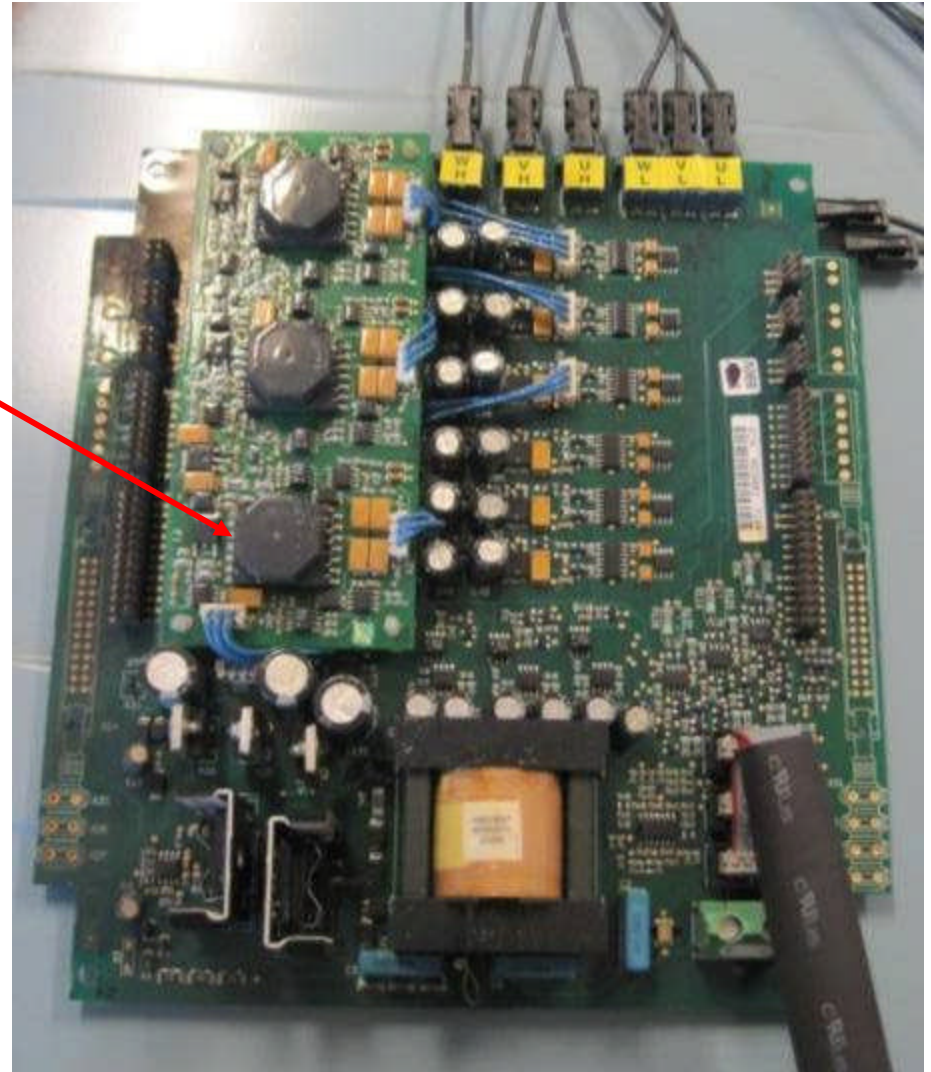
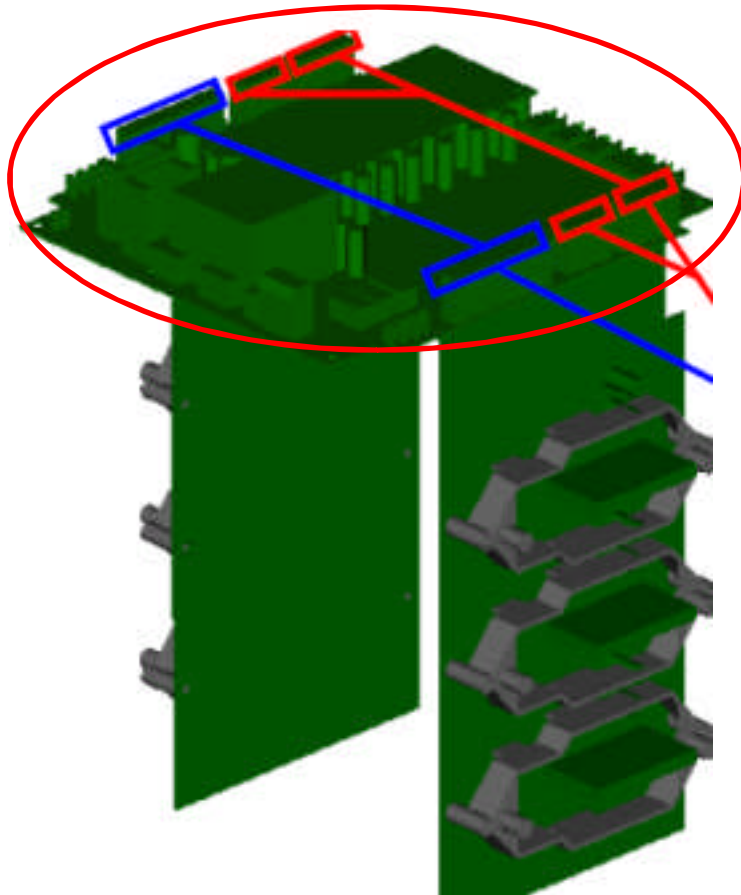

EATON LCX9000 Measurement Board



Turn to the Experts.™

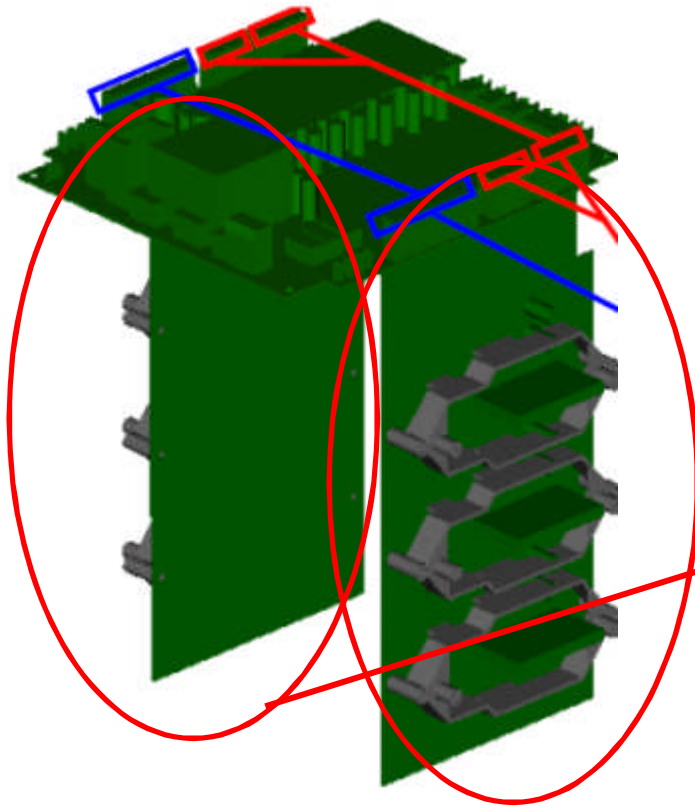

EATON LCX9000 Measurement Board



PIN Connections

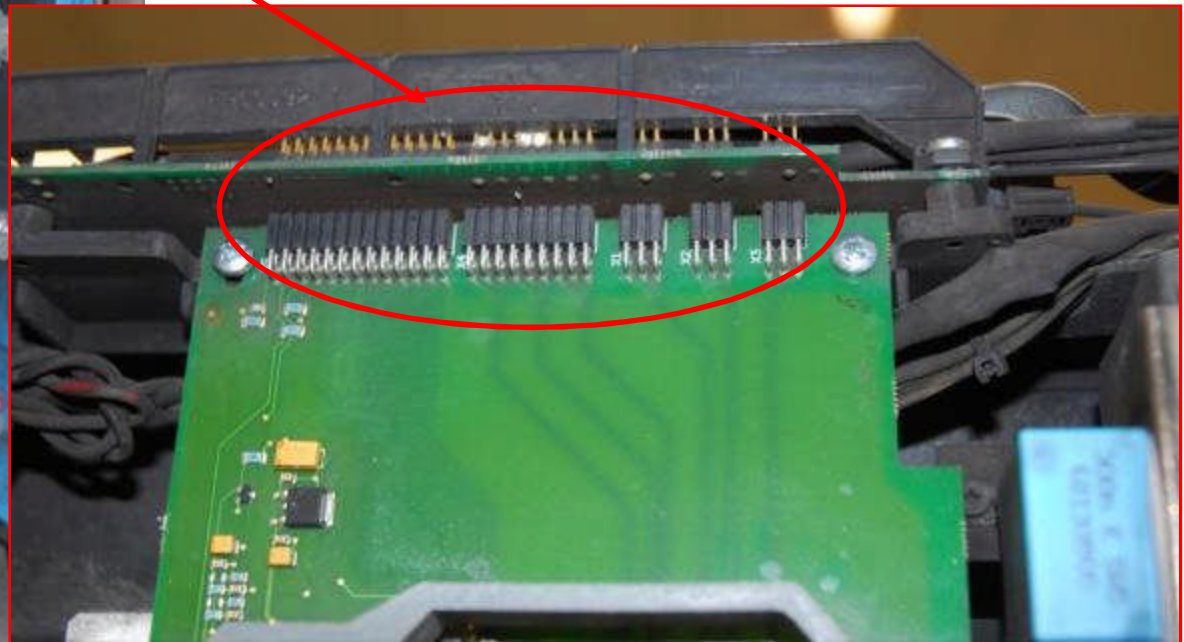

EATON LCX9000

IGBT Modules



IGBT Modules
consist of

1. IGBT Devices
2. Heat Sink
3. Measurement Board



Power modules not serviceable in the field

EATON LCX9000

IGBT Modules

IGBT devices

Heat Sink

Measurement
Board

Driver PCB

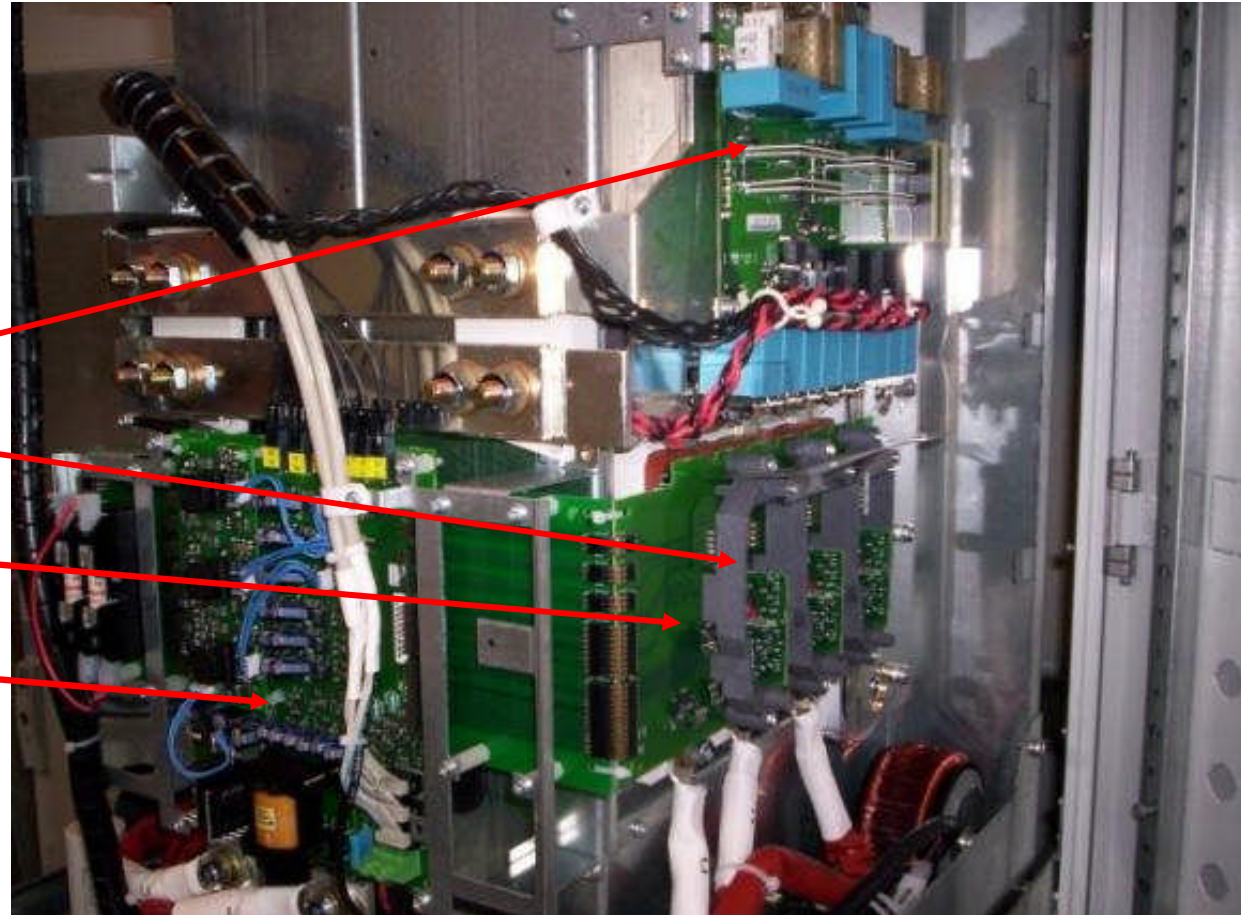

Power modules not serviceable in the field

EATON LCX9000

Measurement Board



Comes with replacement power module

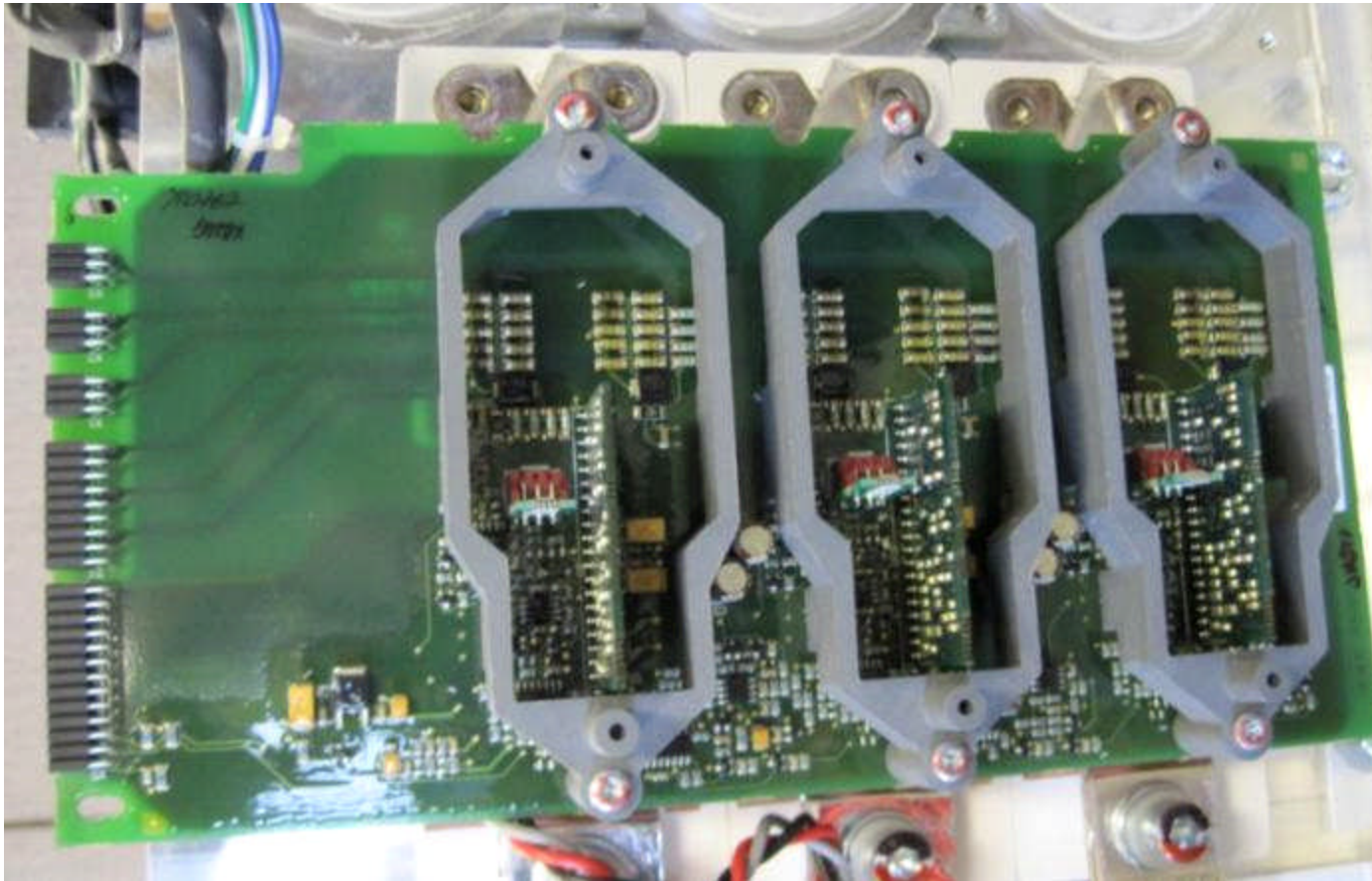

IGBT checks that can be done are done through the measurement board
This board should not be remove/replaced in the field

EATON LCX9000

Power Unit CH72



Turn to the Experts.™

Burden resistors
"calibrate" the
power module
to the frame
size

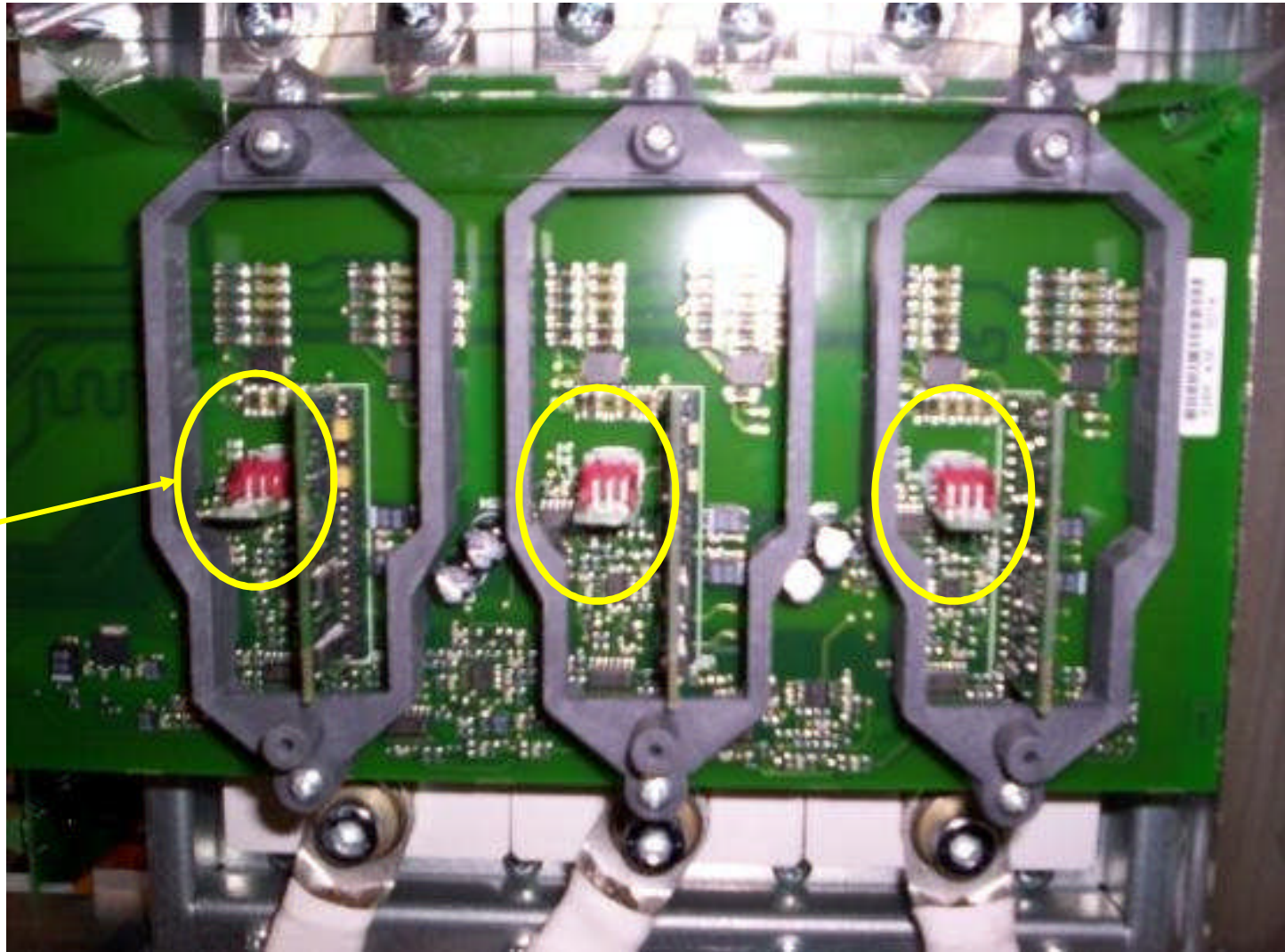

EATON LCX9000

Rectifier Board



Rectifier Board

EATON LCX9000

Opto Coupler Board

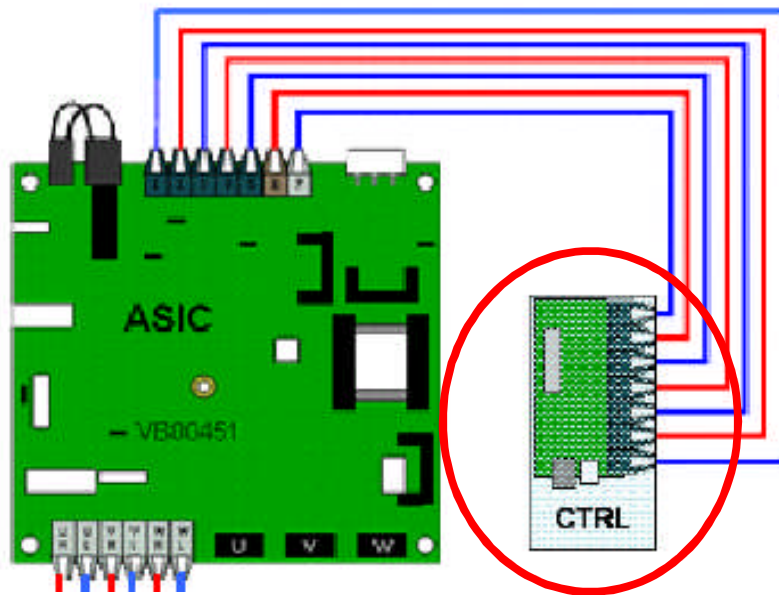

- Mounted behind logic module
- Connected to logic module & ASIC Board
- Takes signal and distribute to all other boards set
- Need reprogramming when replaced
- Input serial # in “device properties”
- Converts board signal to fiber optic signal

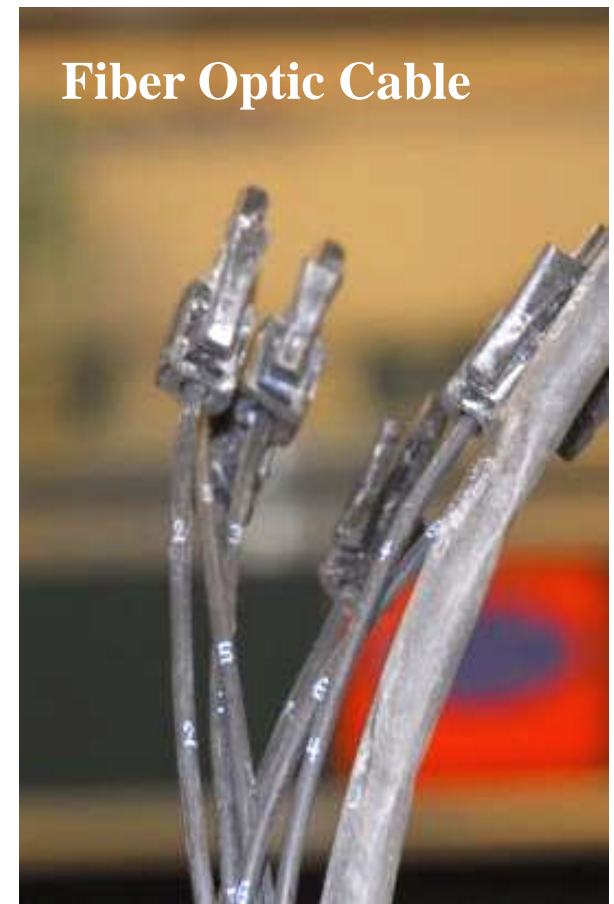

EATON LCX9000

Opto Coupler Board



Turn to the Experts™

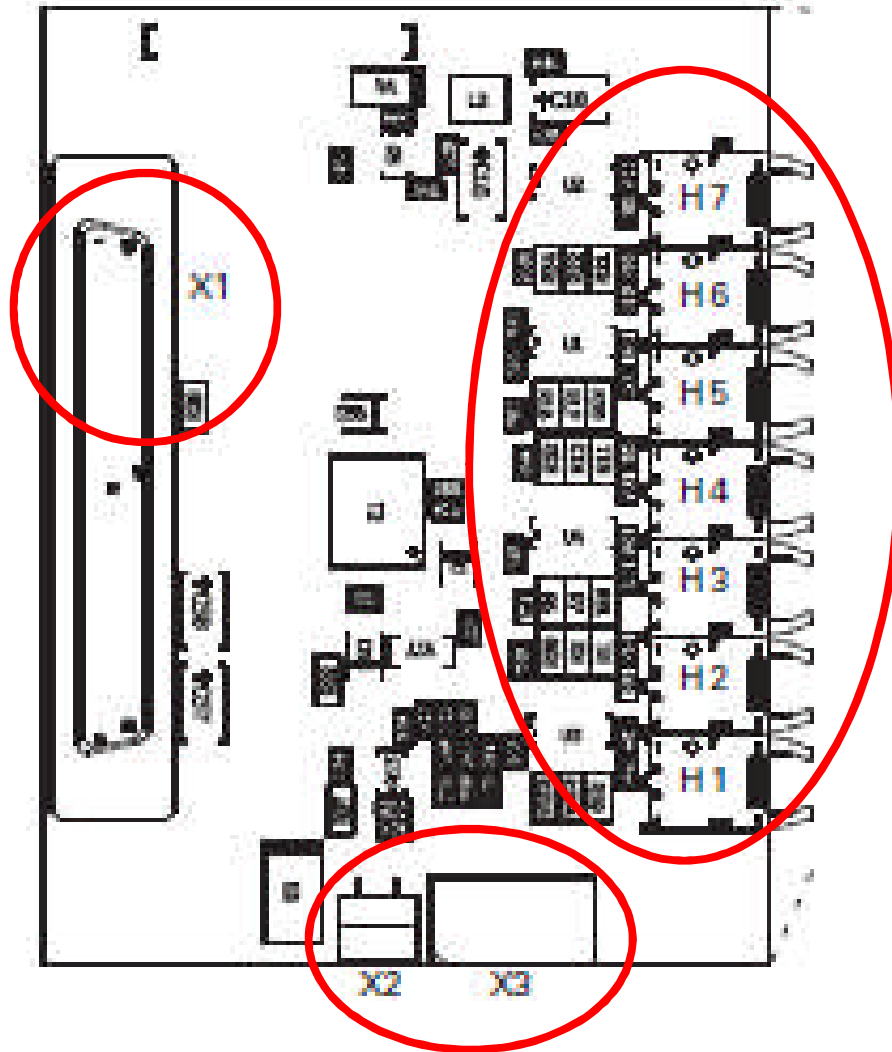

Terminal	Description
Optical Terminals on Optical Cable Adapter Board	
H1	Gate control enable
H2	Phase U control
H3	Phase V control
H4	Phase W control
H5	ADC synchronization
H6	Bus data from control board to ASIC
H7	Bus data from ASIC to control board

Terminal	Description
Other Terminals on Adapter Board	
X1	Control board connection
X2	Supply voltage 24V _{in} (from power unit ASIC)
X3	Supply voltage 24V _{in} (customer); <ul style="list-style-type: none"> • Max. current 1A • Terminal #1: + • Terminal #2: -

EATON LCX9000

Pulse Width Modulation



PWM = Pulse Width Modulation

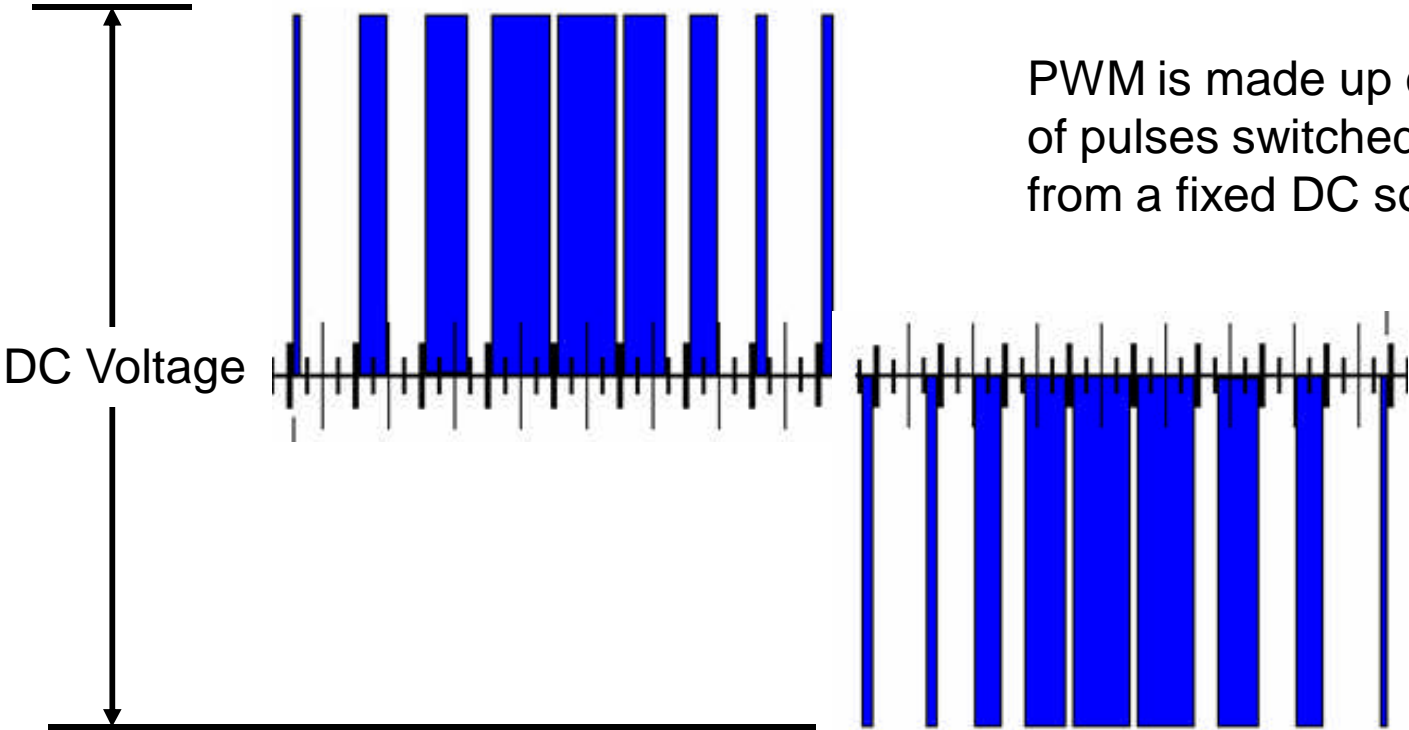

PWM is made up of a series of pulses switched on and off from a fixed DC source

EATON LCX9000

Pulse Width Modulation

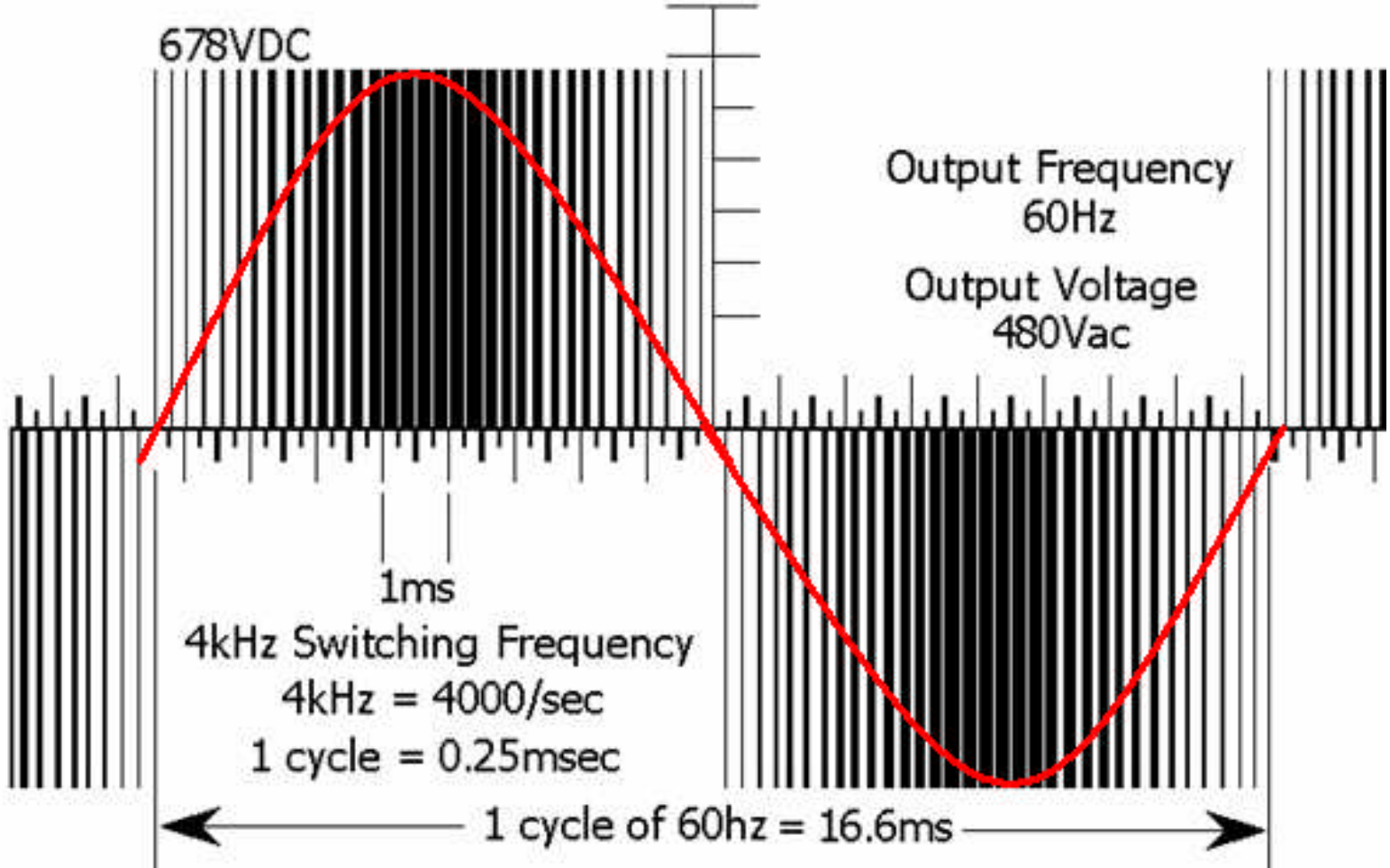

EATON LCX9000

Switching Frequency



Switching frequency is part of how the PWM waveform is established

Switching Frequency determines how many positive and negative pulses are contained in one cycle of power

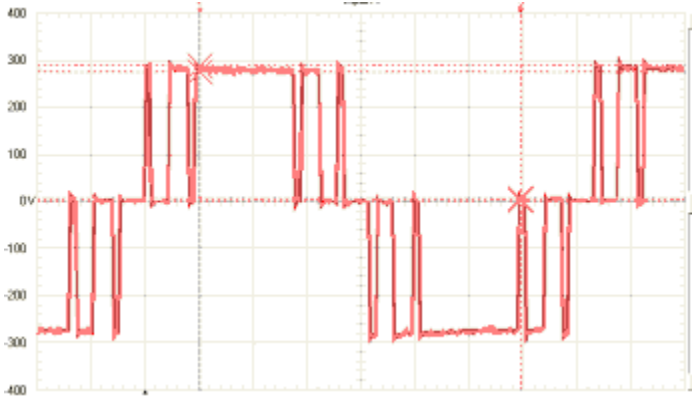

60Hz Output @ 1 KHz

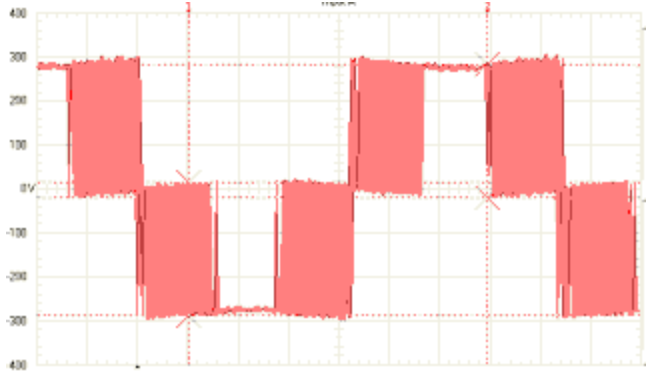

60Hz Output @ 10 KHz

EATON LCX9000

Lower vs. Higher

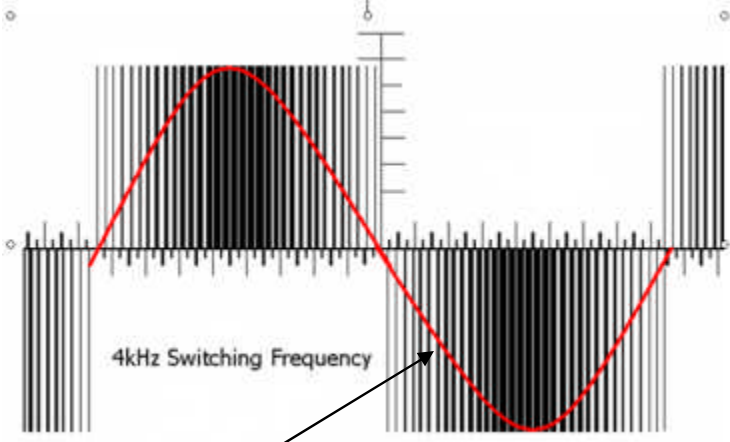
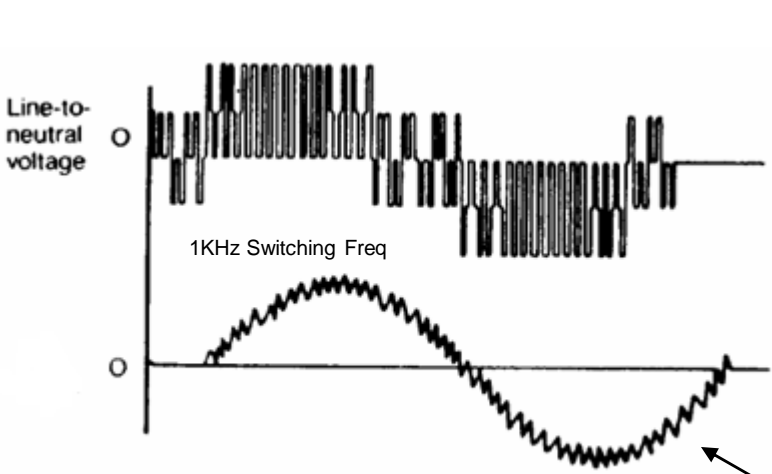

Line Current

Lower Switching Frequency

- Less VFD Heating
- Noisier Motor
- More motor heating

Higher Switching Frequency

- More VFD Heating
- Quieter Motor
- Less Motor Heating

EATON LCX9000

Drive Basic

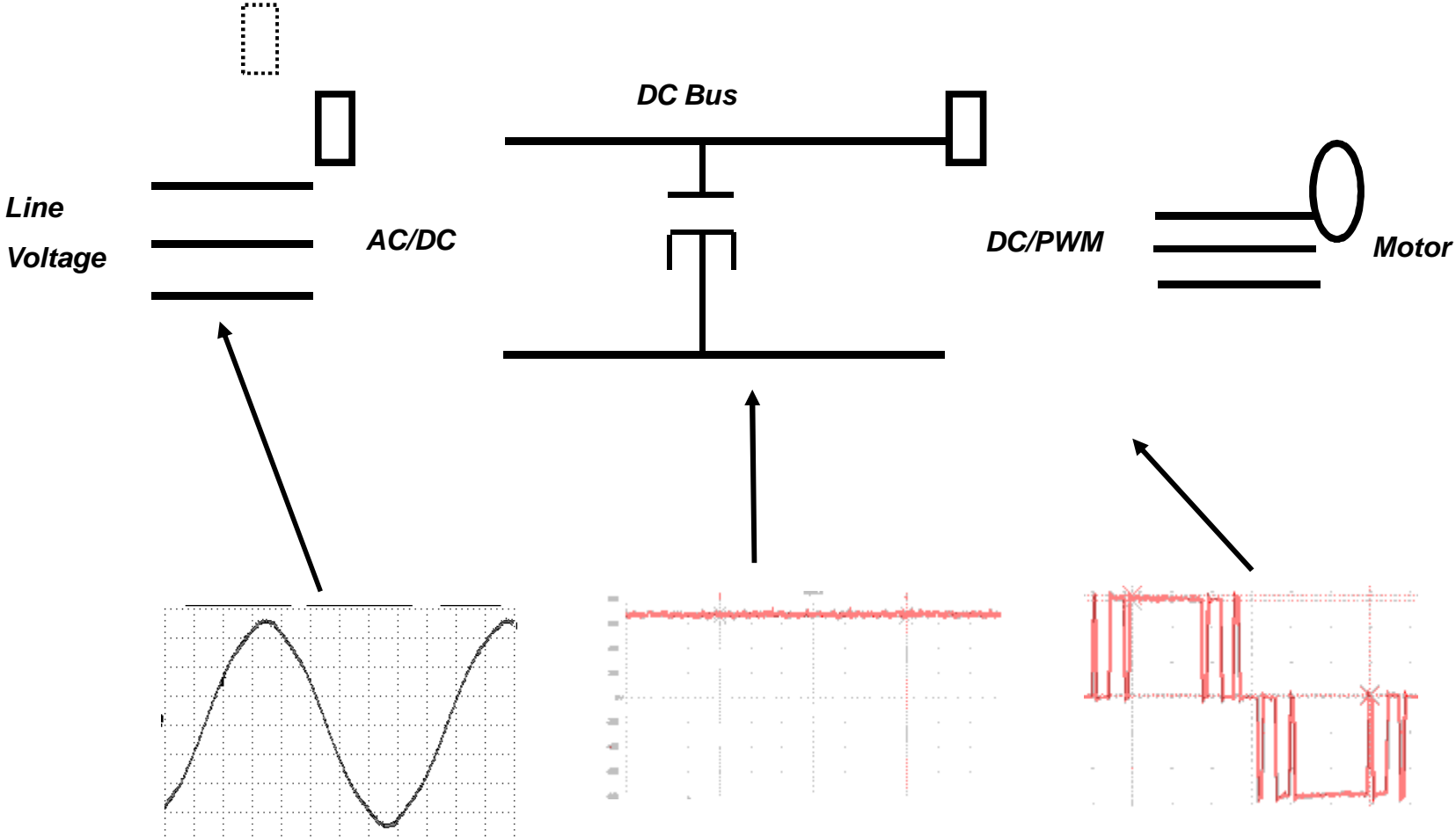

EATON LCX9000



Turn to the Experts™

PWM

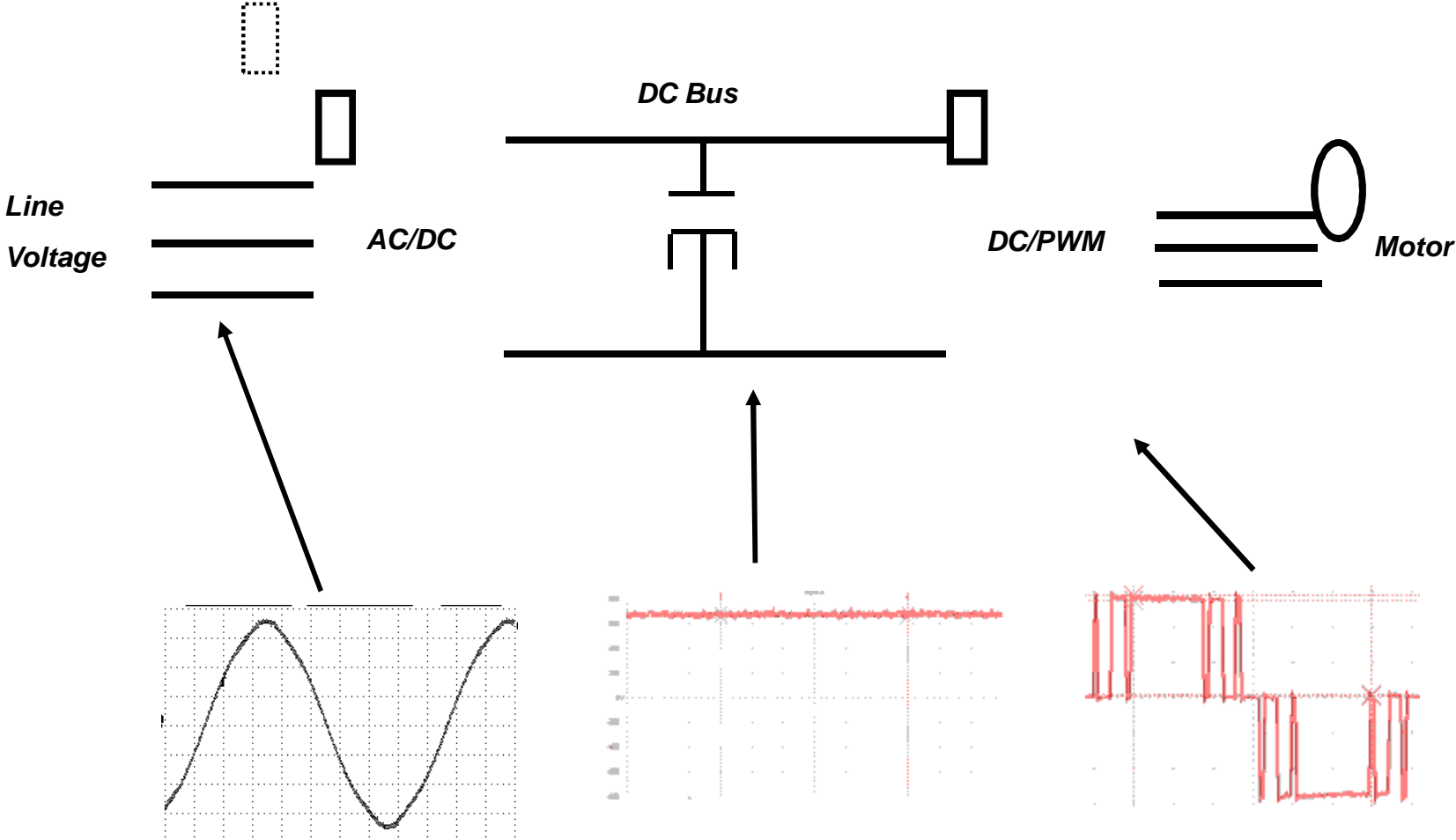

AC Powered LCX9000 all use same basic operating principle

EATON LCX9000

Lower vs. Higher

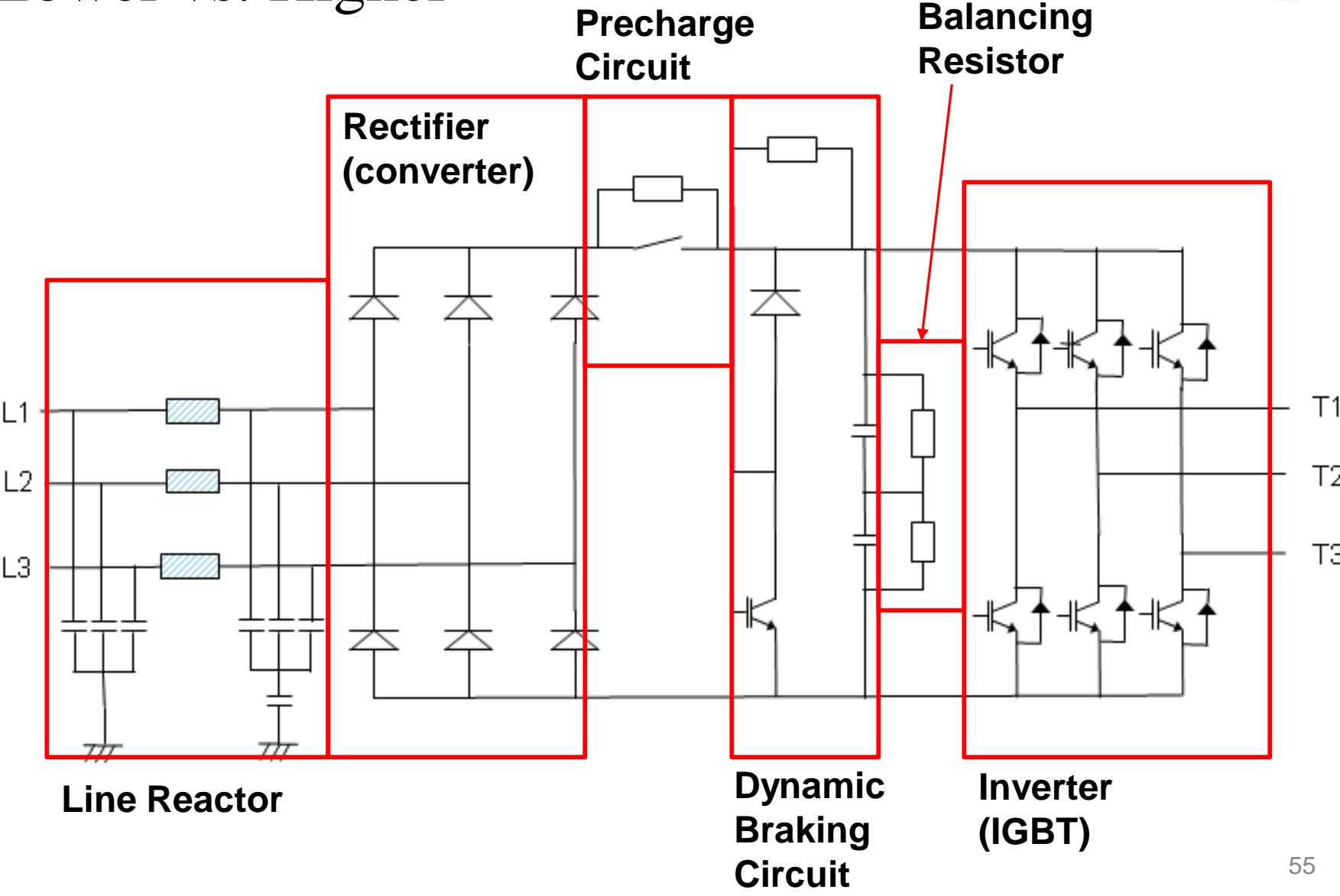

EATON LCX9000



Turn to the Experts.™

Detail drive Layout and drive wiring

EATON LCX9000

Power Units



Turn to the Experts.™

CH72



Table 1 — VFD Frame Size and Application

EATON FRAME SIZE	CARRIER PART NO.	MAXIMUM CONTINUOUS AMP RATING
CH72	19XVE0485	485
	19XVE0550	550
	19XVE0605	605
	19XVE0680	680

EATON LCX9000

CH72 Frames



Turn to the Experts™



Line L1, L2, L3
DC+, DC-



Load U, V, W

EATON LCX9000

Bus Capacitors



Turn to the Experts™



CH72

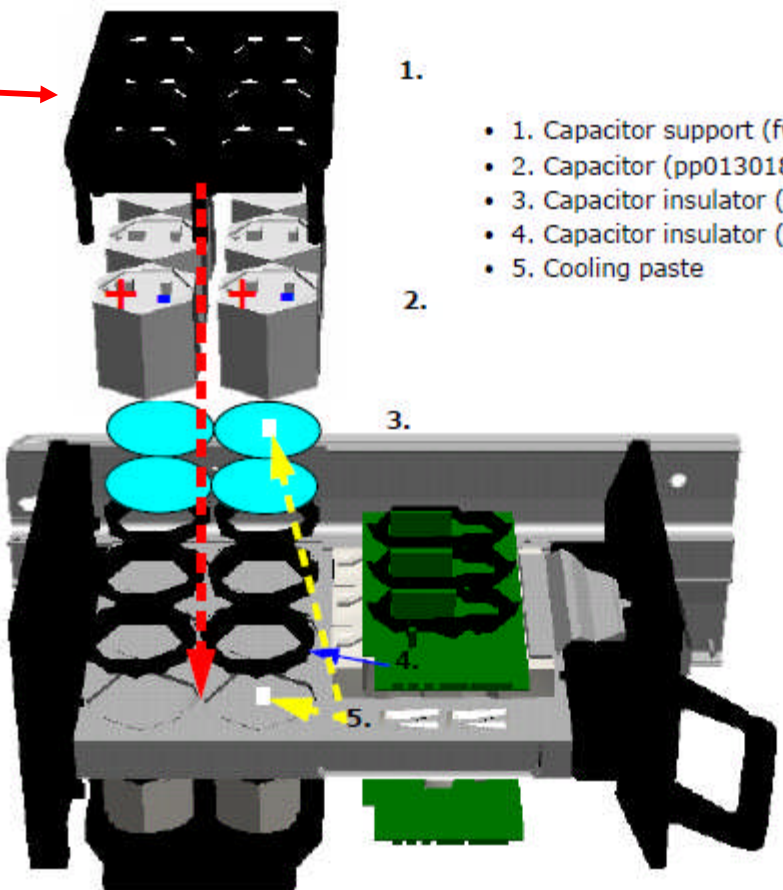

- 1.
 - 2.
 - 3.
 - 4.
 - 5.
- 1. Capacitor support (fw60060) M5*60 (3Nm).
 - 2. Capacitor (pp013018,pp01005).
 - 3. Capacitor insulator (fw60069).
 - 4. Capacitor insulator (fw60061).
 - 5. Cooling paste

EATON LCX9000

Bus Bar



Turn to the Experts™

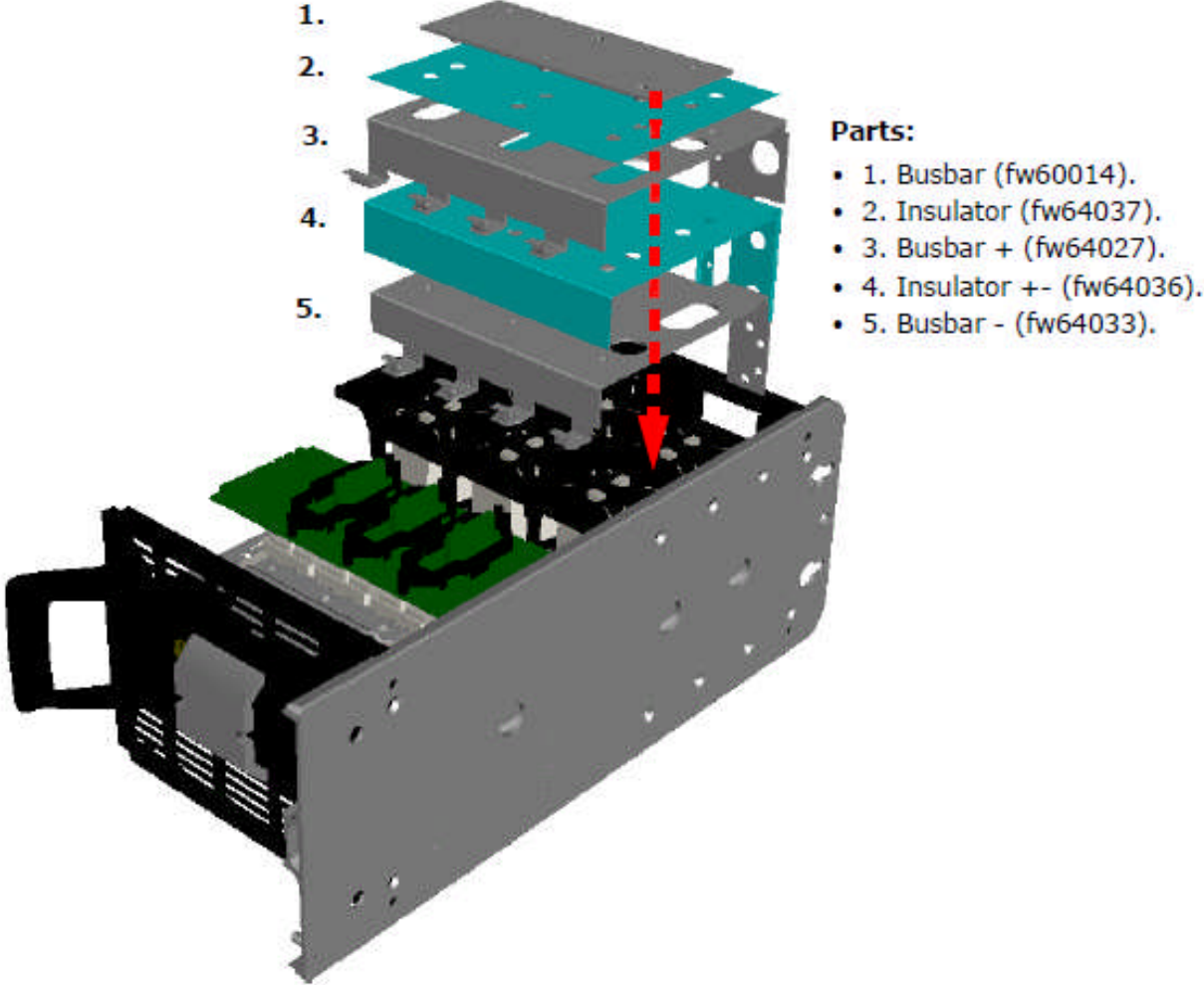

Bus Bar Configuration eliminates cabling

EATON LCX9000 Power Unit CH72



IGBT Modules

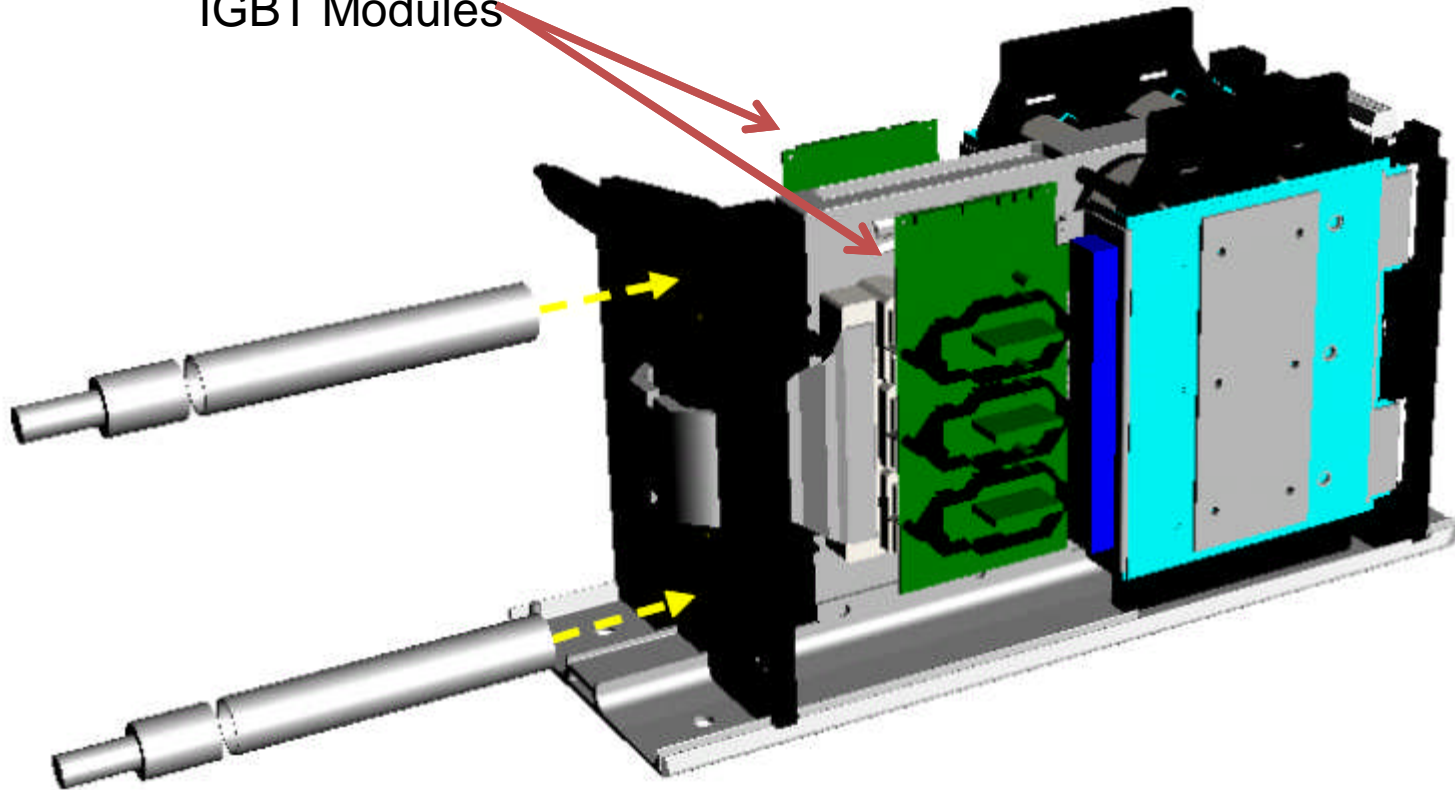

EATON LCX9000

Power Unit CH72



Turn to the Experts™

Control Schematic - CH72 Frame

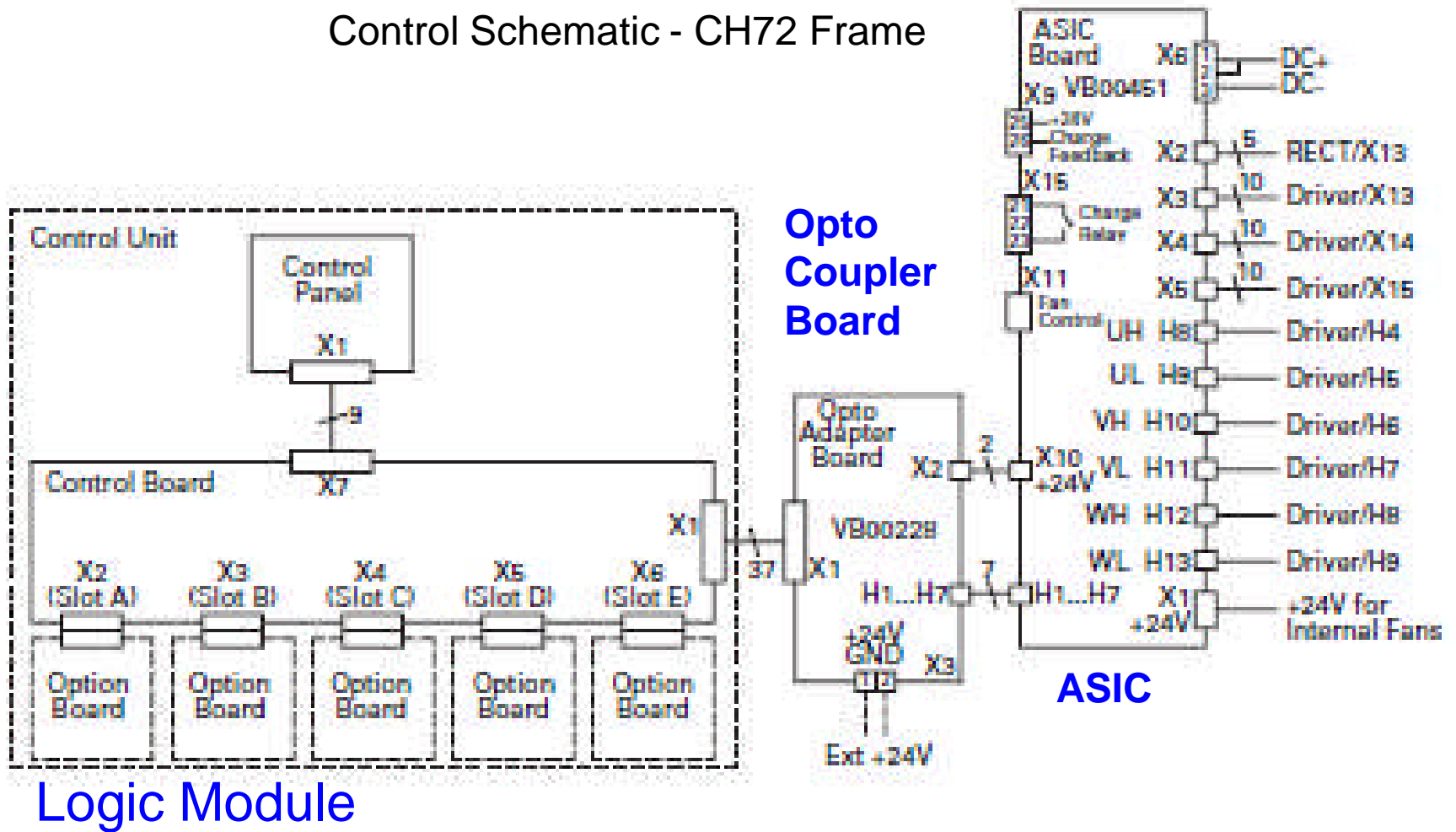

EATON LCX9000 Power Unit CH72

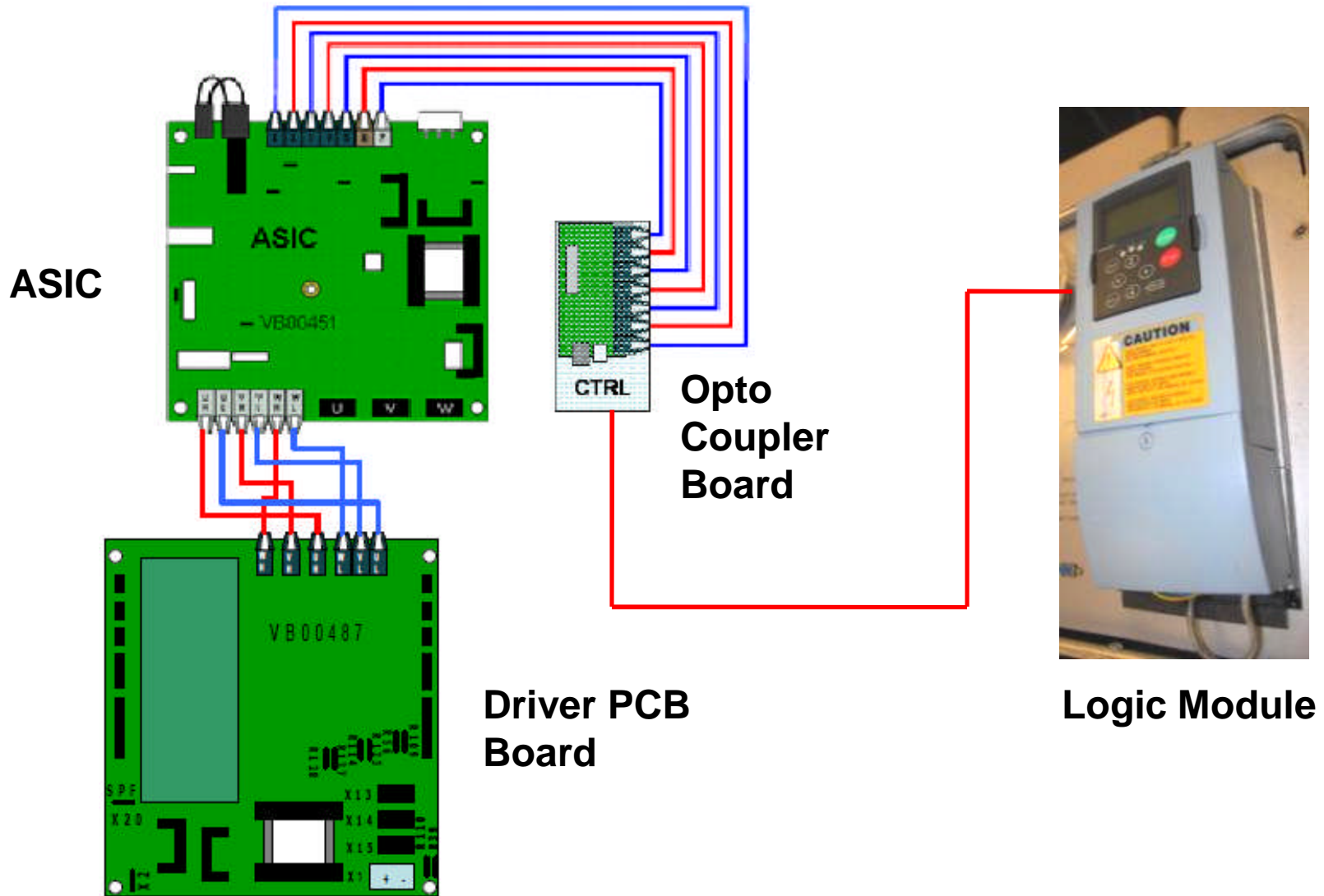

EATON LCX9000



Turn to the Experts™

Drive Wiring CH72

LCX9000 Power Schematic
CH72 Frame

Precharge

Rectifier

Bus Caps

Input

Filter

Output

Inverter

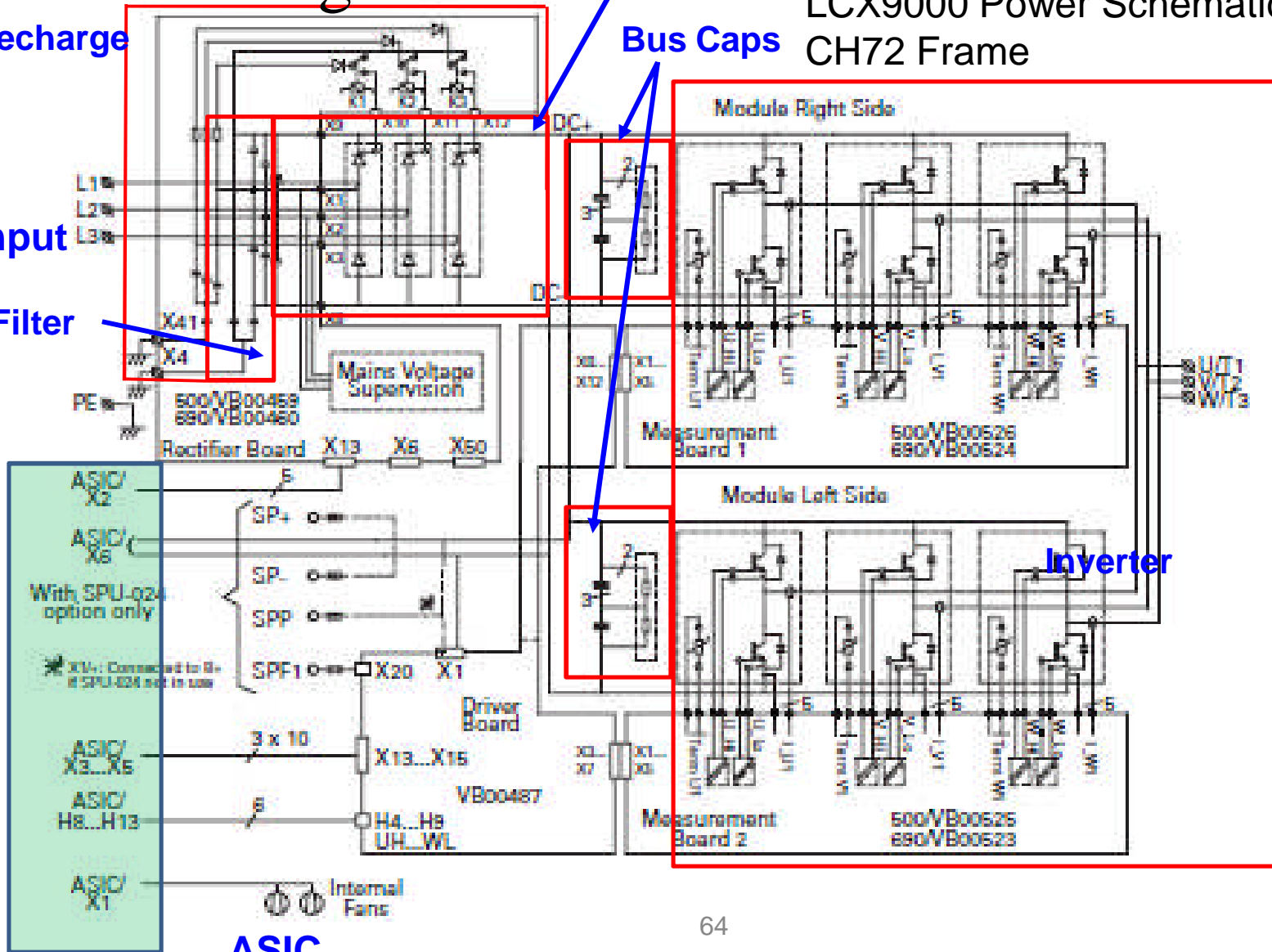

ASIC

EATON LCX9000

Power Unit CH63



CH63

Table 1 — VFD Frame Size and Application

EATON FRAME SIZE	CARRIER PART NO.	MAXIMUM CONTINUOUS AMP RATING
CH63	19XVE0765	765
	19XVE0855	855
	19XVE0960	960
	19XVE1070	1070



EATON LCX9000

CH63 Frames

Two power modules
Rectifiers on Left side
IGBT on both side

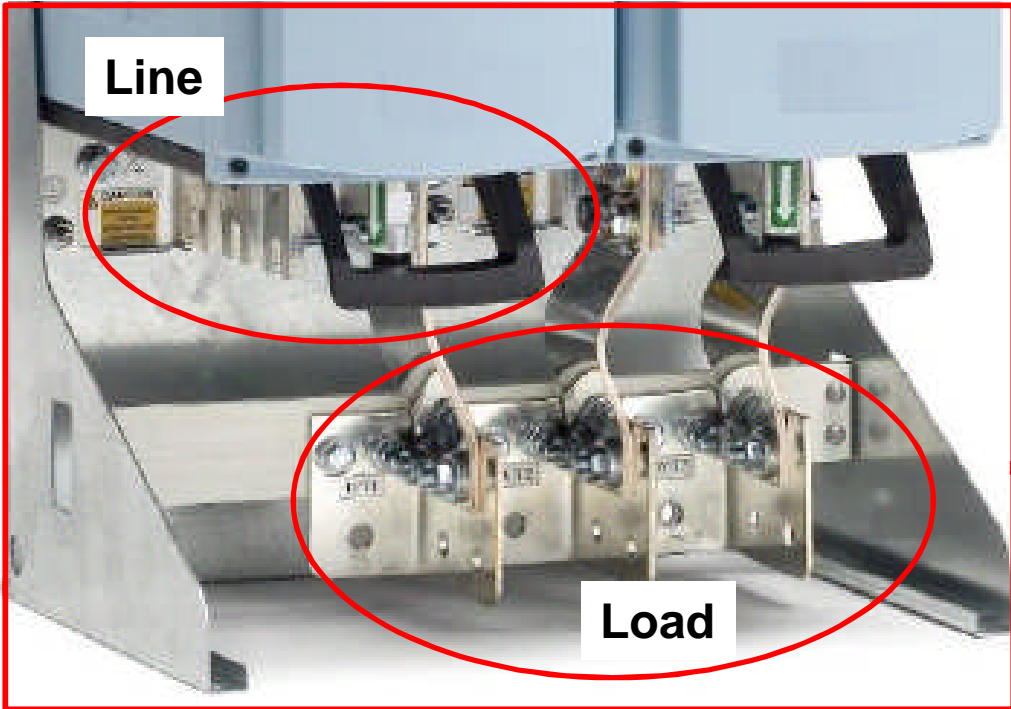

EATON LCX9000

Power Unit CH63



CH63 consists of two power modules

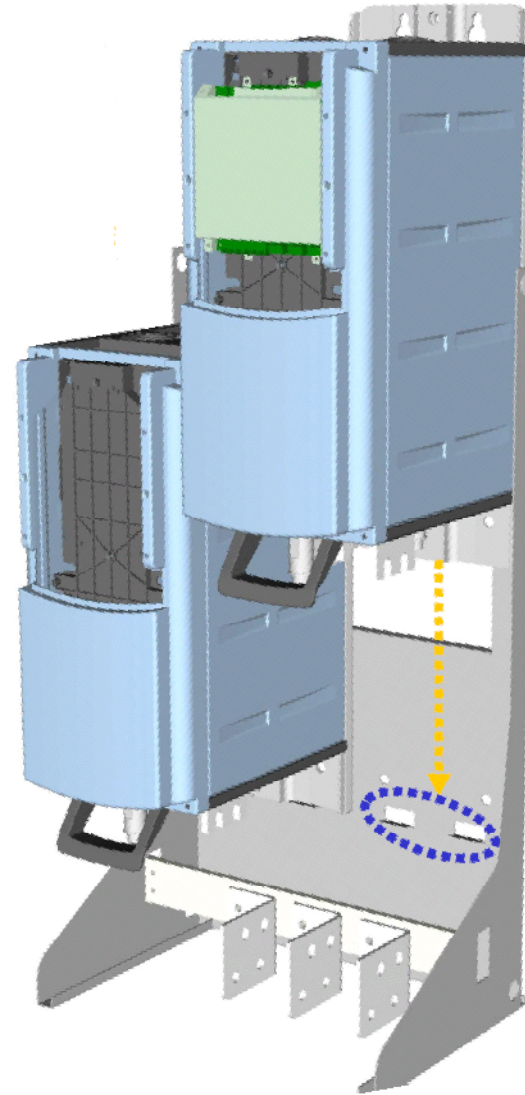

EATON LCX9000 Power Unit CH63

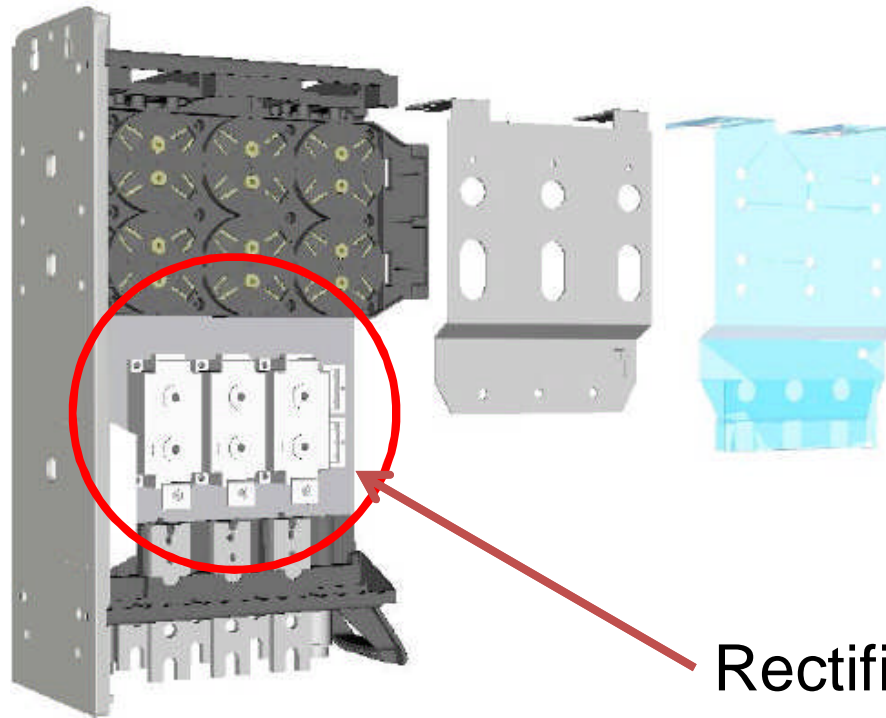

Rectifiers are installed on the left hand module - Left side

Rectifiers

IGBT Module installed opposite the rectifiers

EATON LCX9000 Power Unit CH63



IGBT Modules installed on both sides of the right hand block

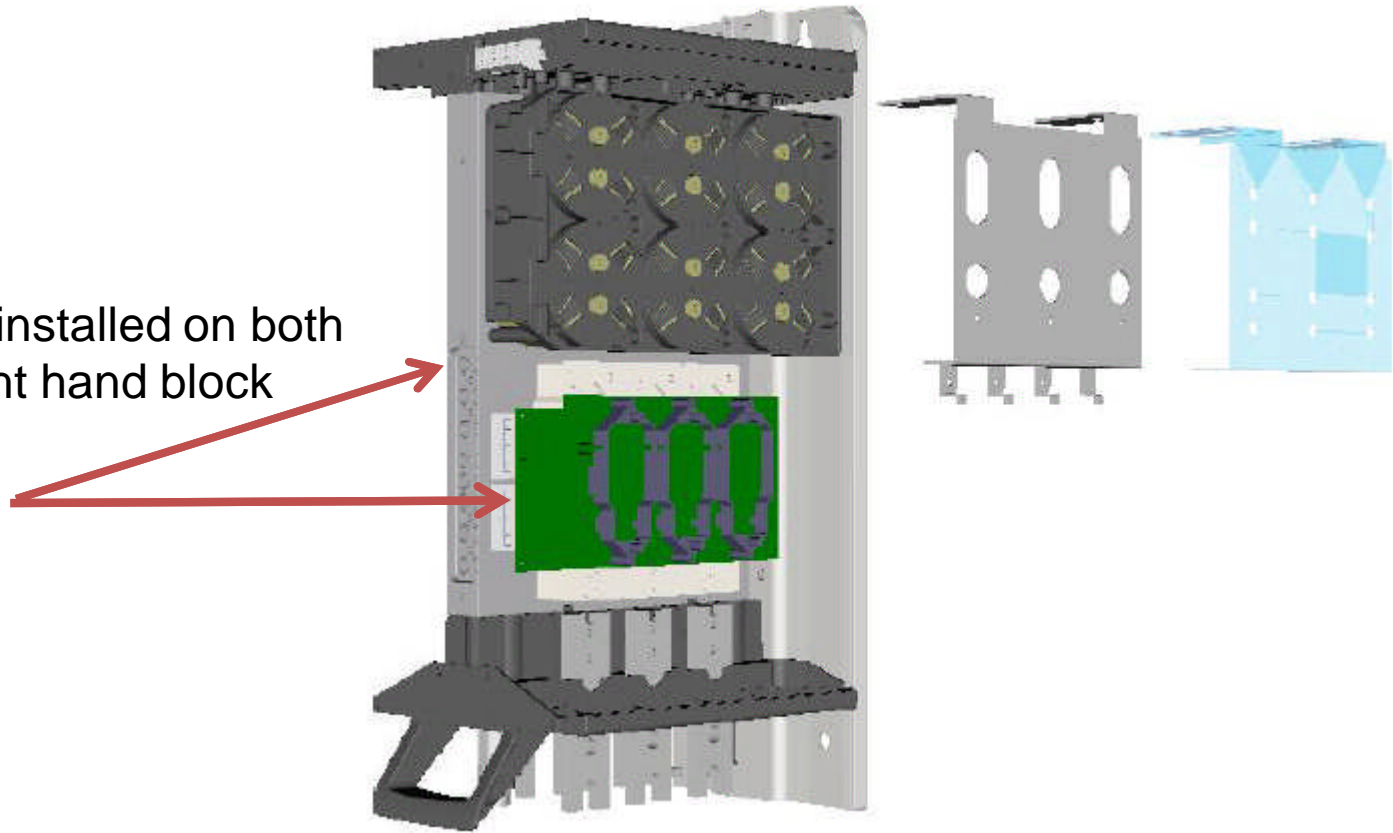

EATON LCX9000

Power Unit CH63



Turn to the Experts™

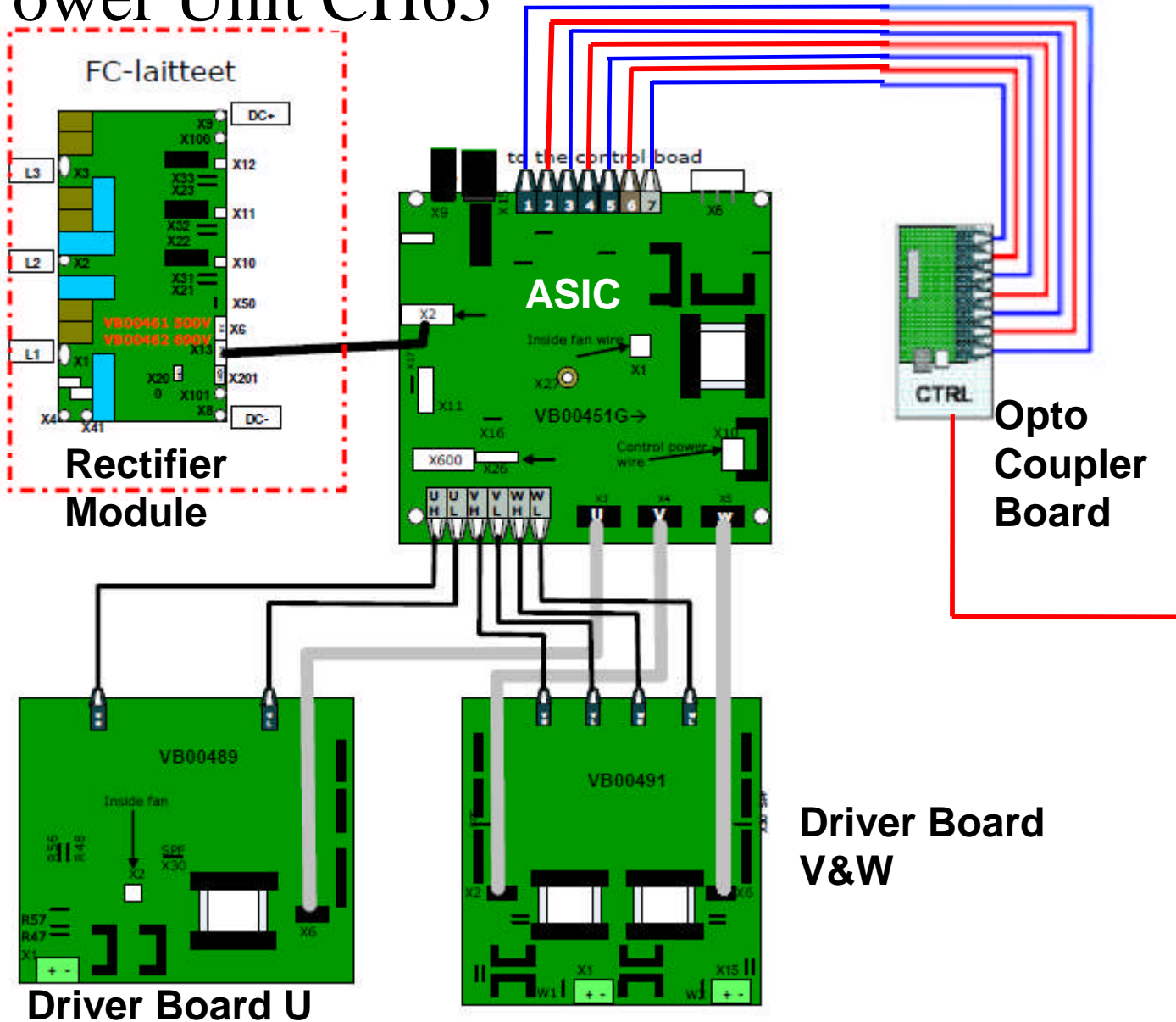

Logic Module

EATON LCX9000

Board Wiring

Control Schematic – CH63 Frame



Turn to the Experts™

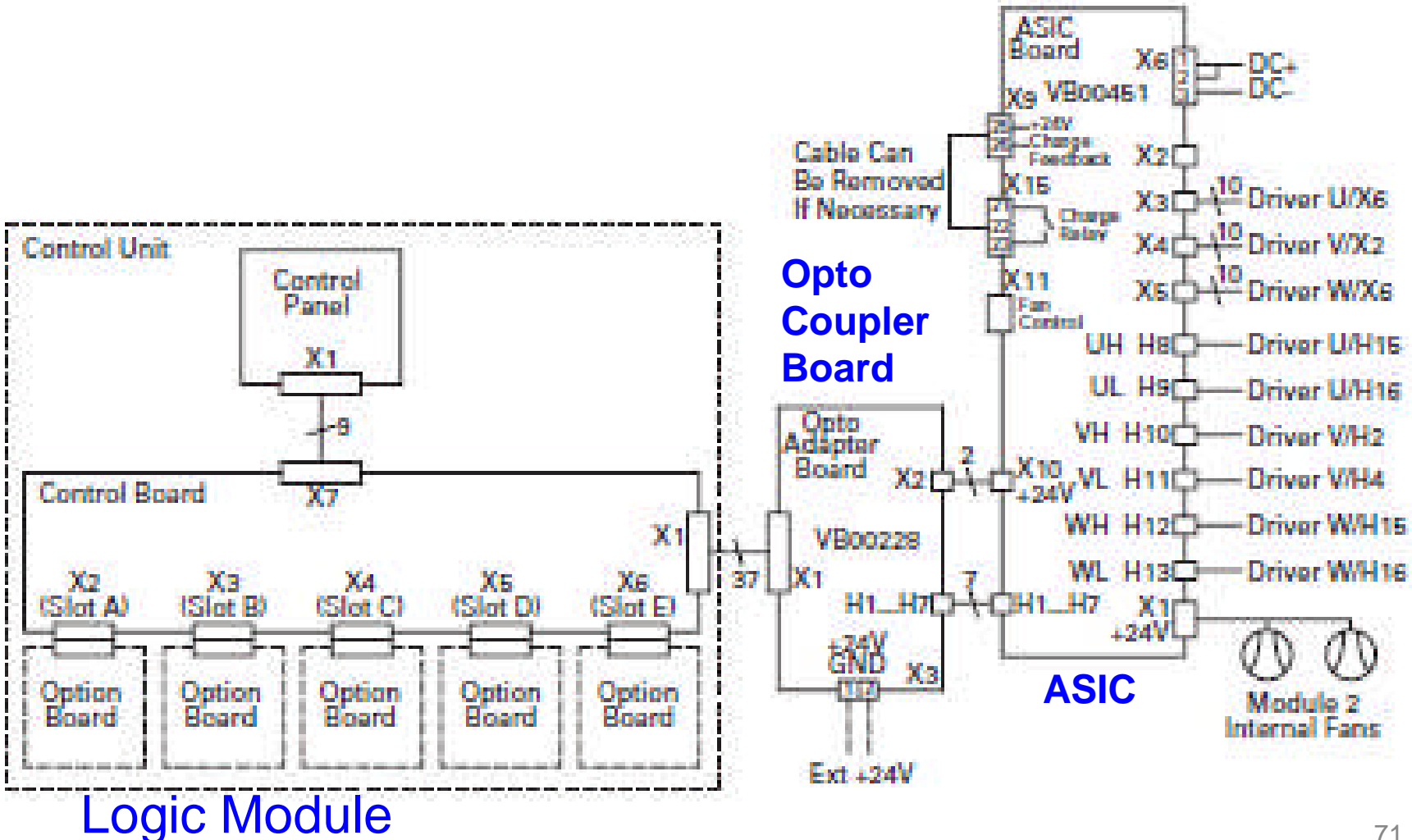



Turn to the Experts™

EATON LCX9000

Drive Wiring CH63-Left Block

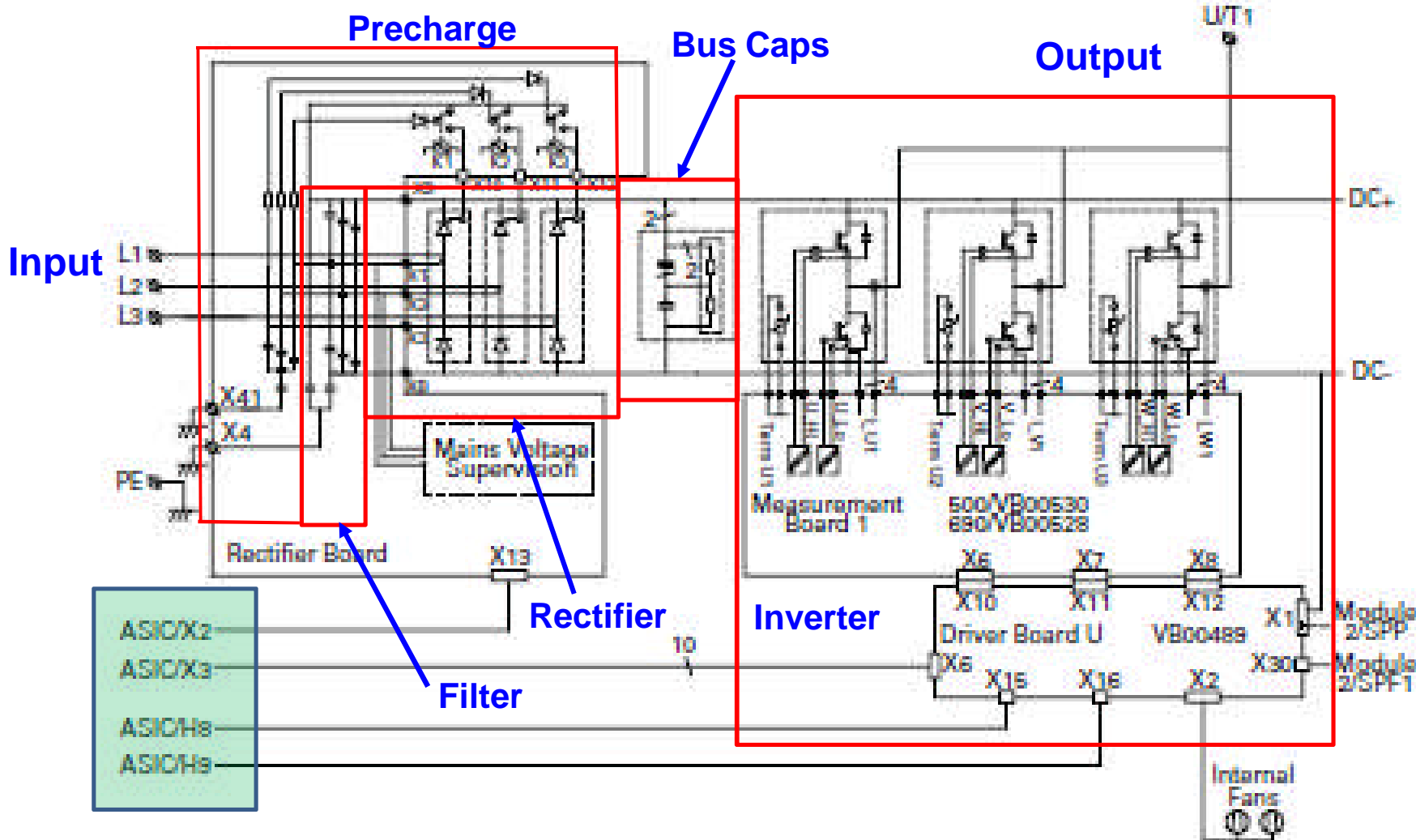

EATON LCX9000

Drive Wiring CH63 – Right Block



Turn to the Experts™

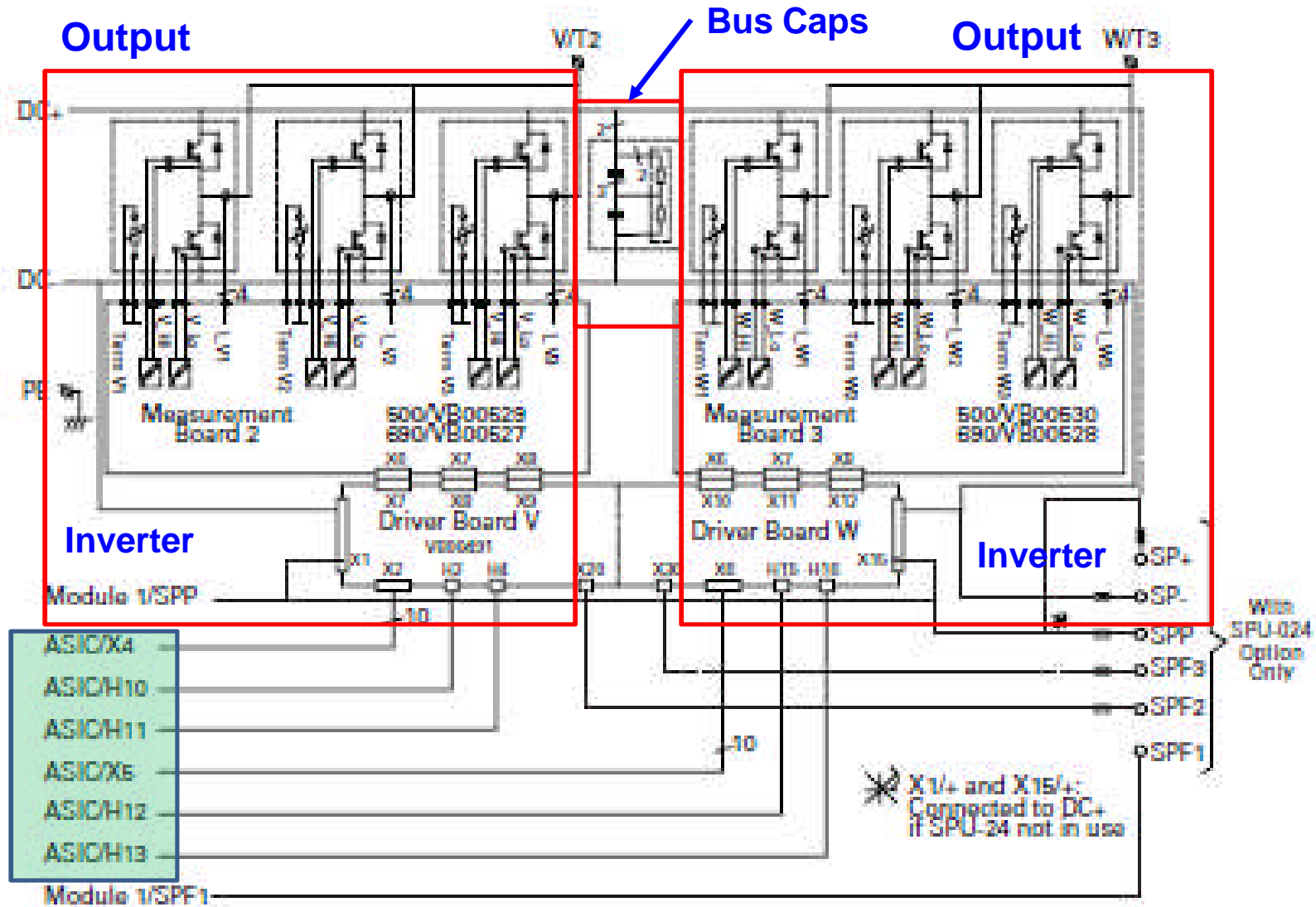

EATON LCX9000

Power Unit CH74 Frame



Turn to the Experts.™

CH74

Table 1 — VFD Frame Size and Application

EATON FRAME SIZE	CARRIER PART NO.	MAXIMUM CONTINUOUS AMP RATING
CH74	19XVE1275	1275
	19XVE1530	1530



EATON LCX9000

Power Unit Ch74



Turn to the Experts.™

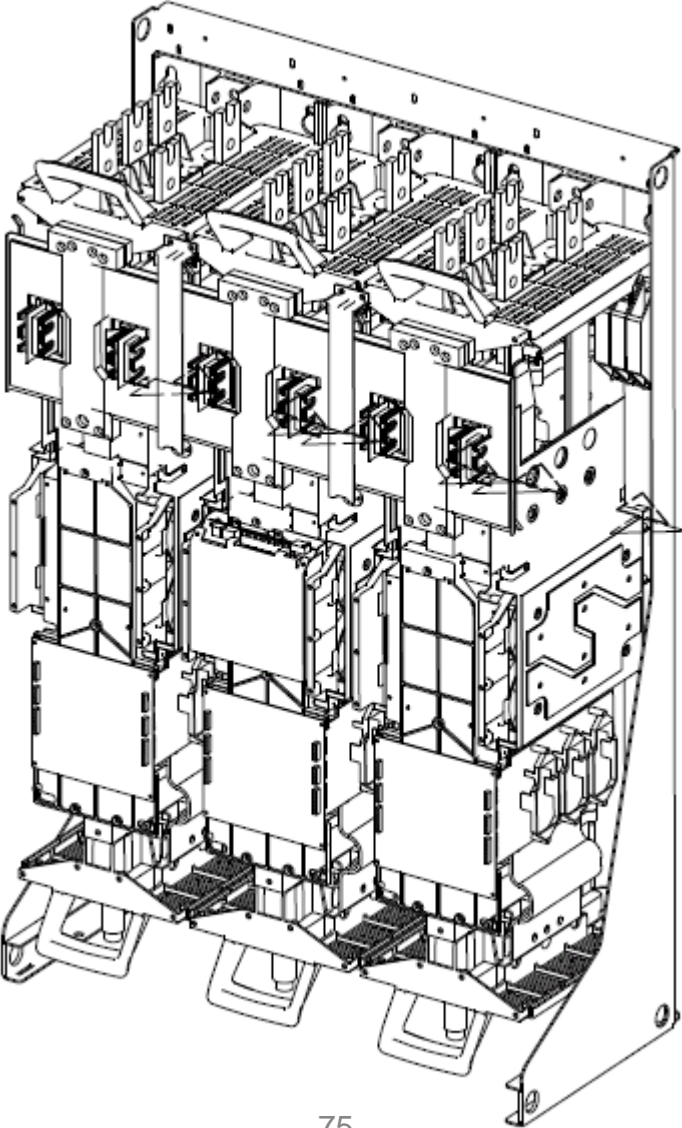

EATON LCX9000

Power Unit Ch74



Turn to the Experts.™

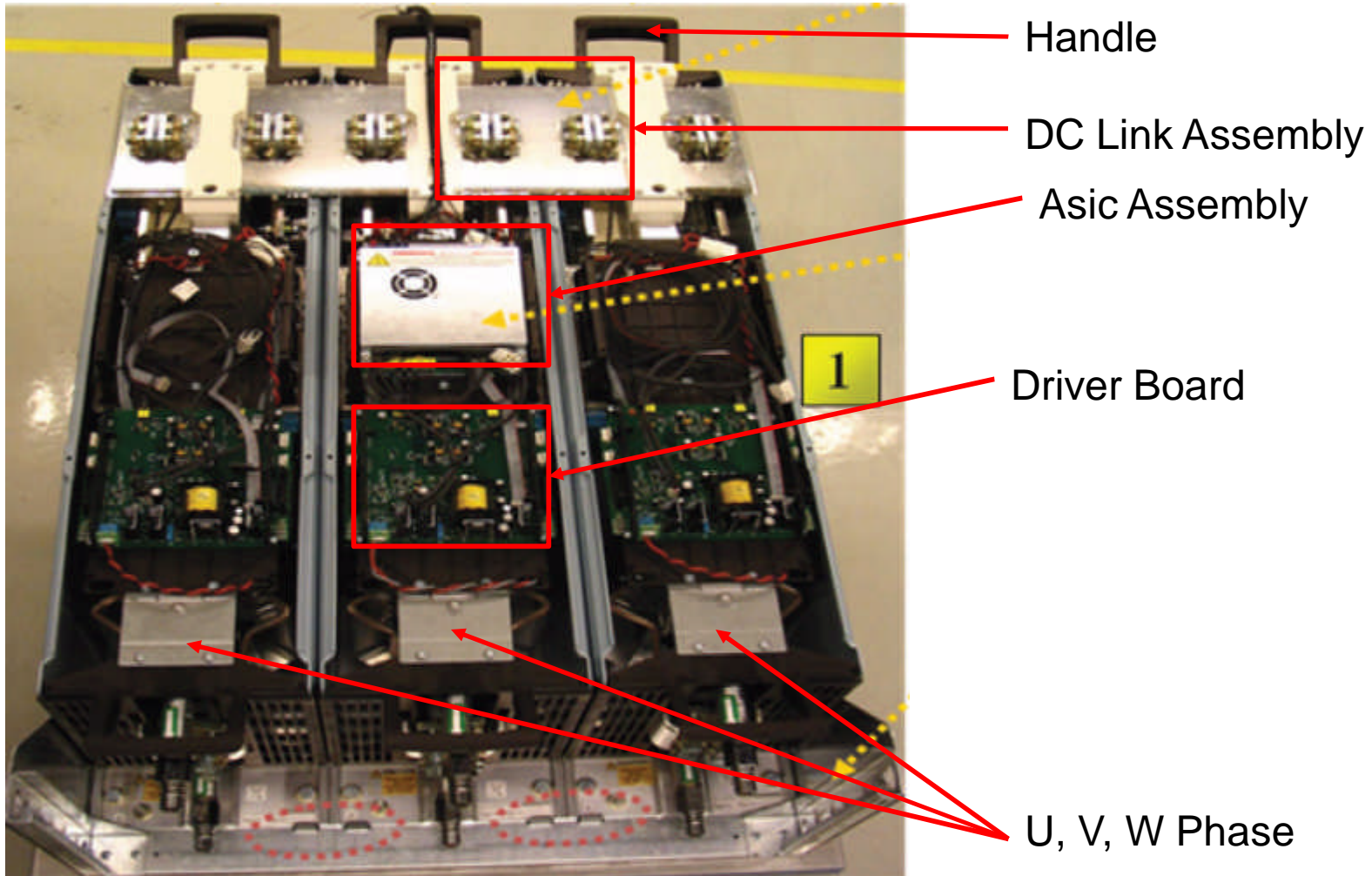

EATON LCX9000

Board Wiring Ch74



Turn to the Experts™

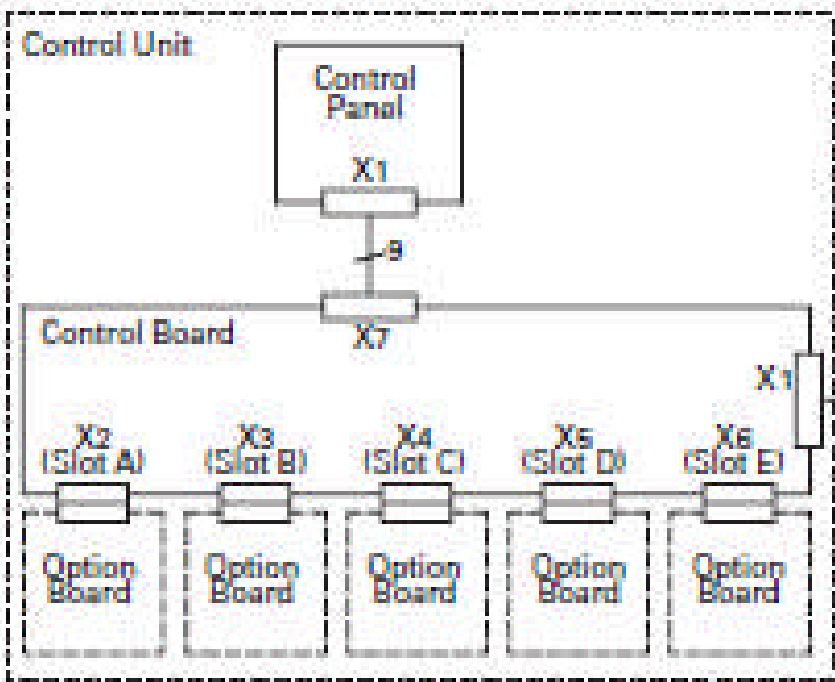

Logic Module

Opto Coupler Board

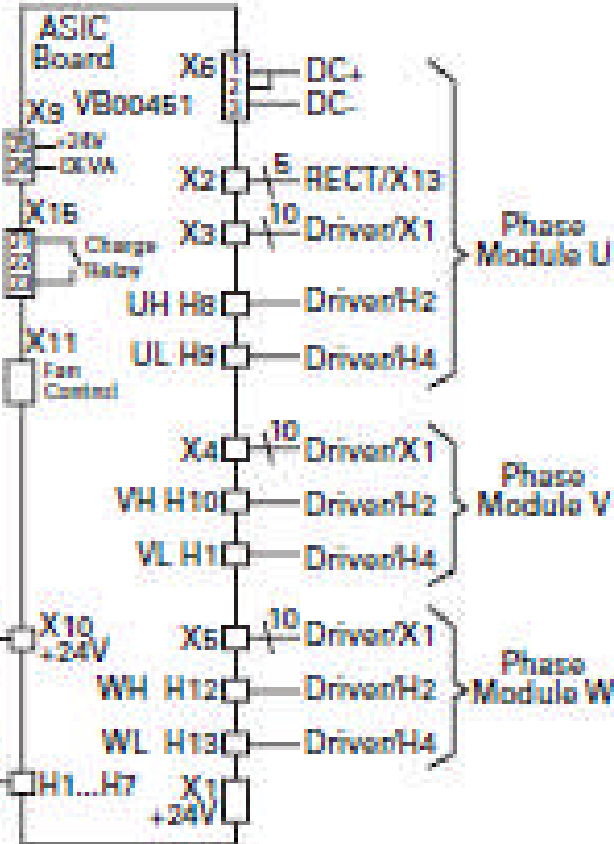
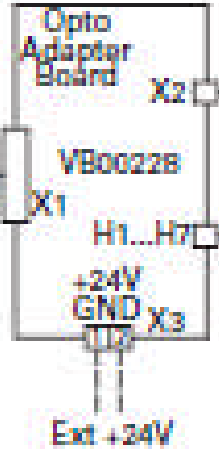

ASIC

EATON LCX9000

Board Wiring Ch74



Turn to the Experts™

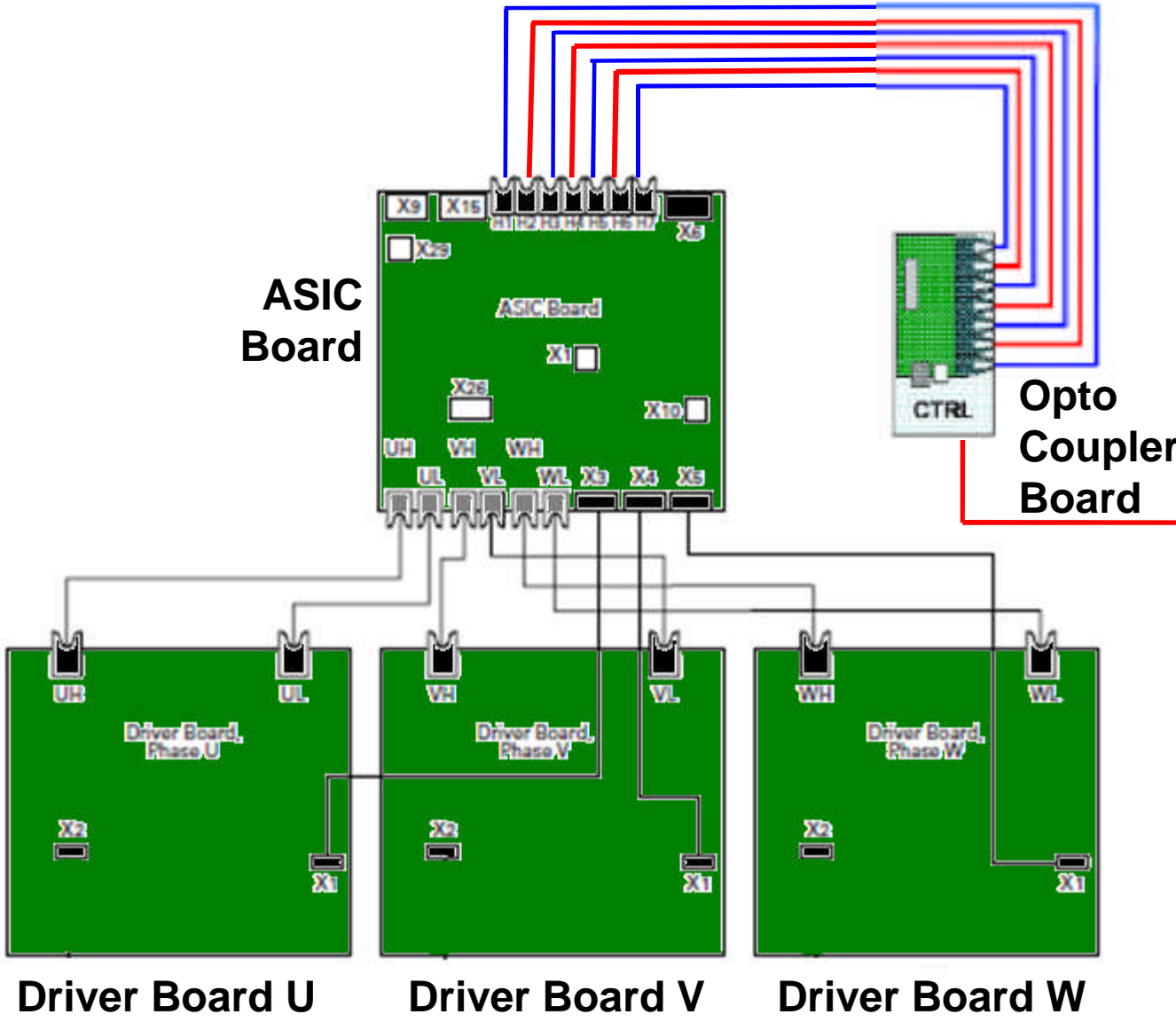

Logic Module

EATON LCX9000

Board Wiring Ch74



Turn to the Experts™

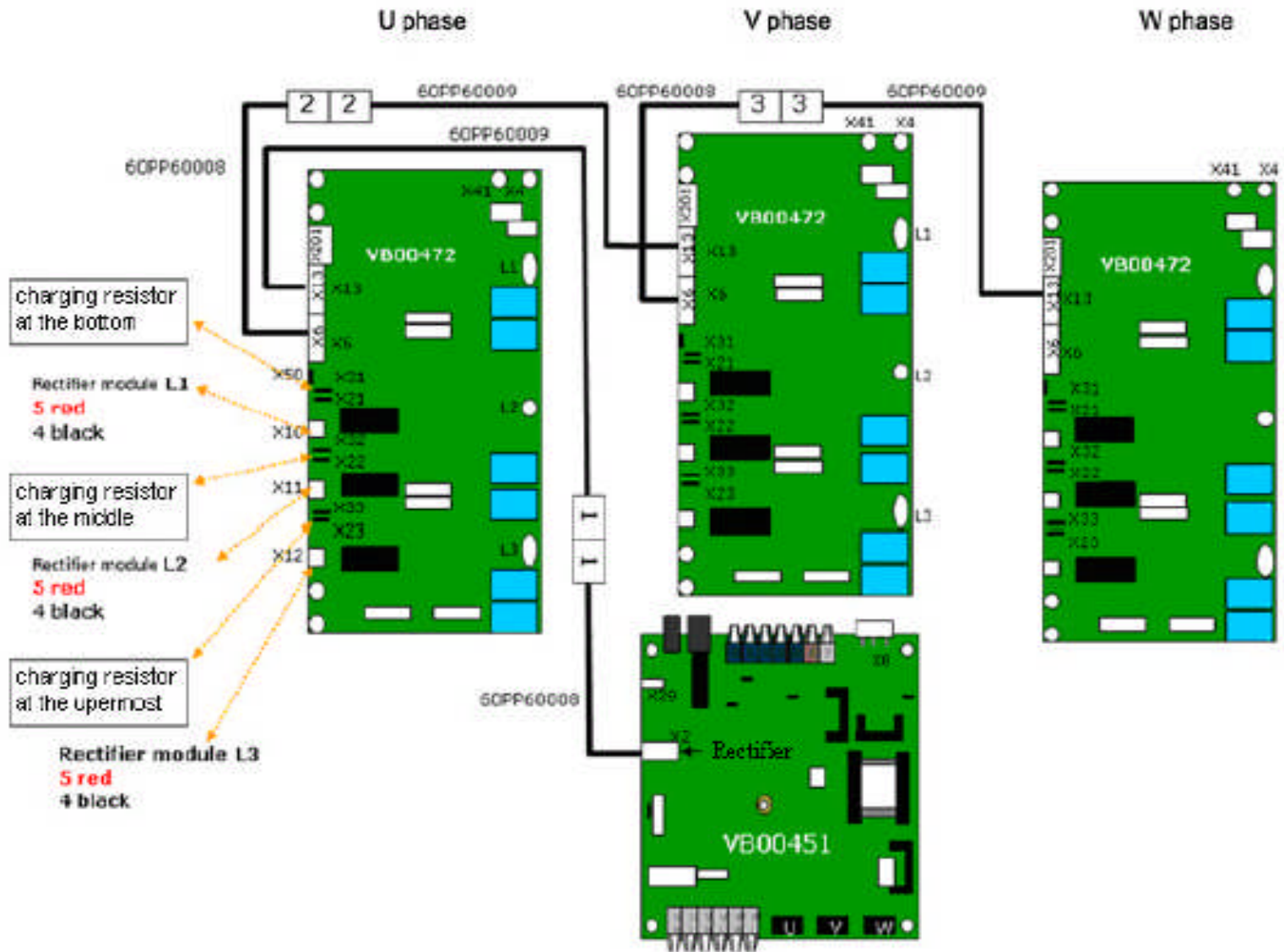



Turn to the Experts™

EATON LCX9000 Drive Wiring CH74

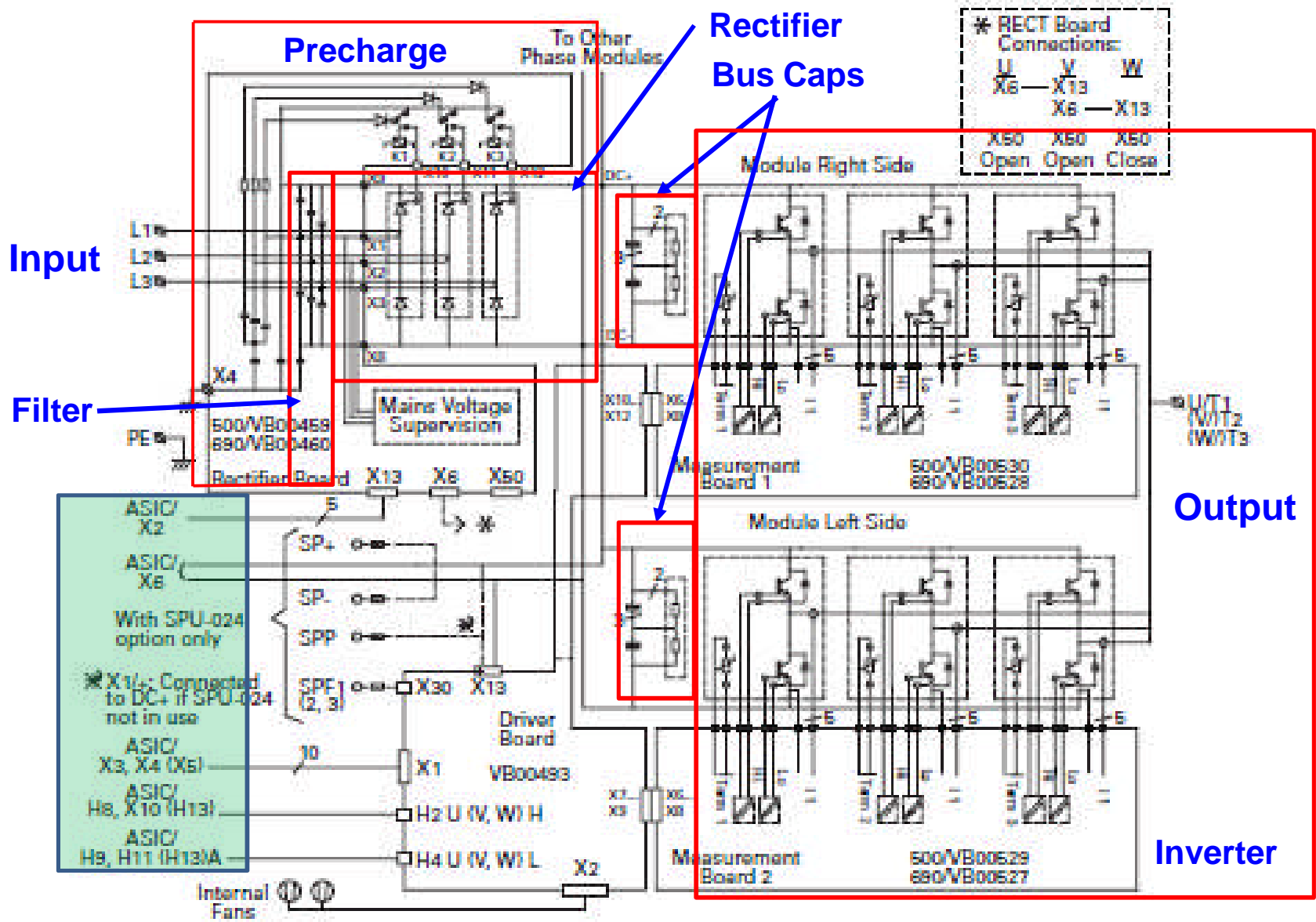

EATON LCX9000



Turn to the Experts.™

Wiring Diagram

202-009004-001 Control Schematic w/o meter package

202-009004-002 Control Schematic w/ meter package

EATON LCX9000



Turn to the Experts.™

Input & Output Connections

EATON LCX9000

Terminal Block Connections



Turn to the Experts.™

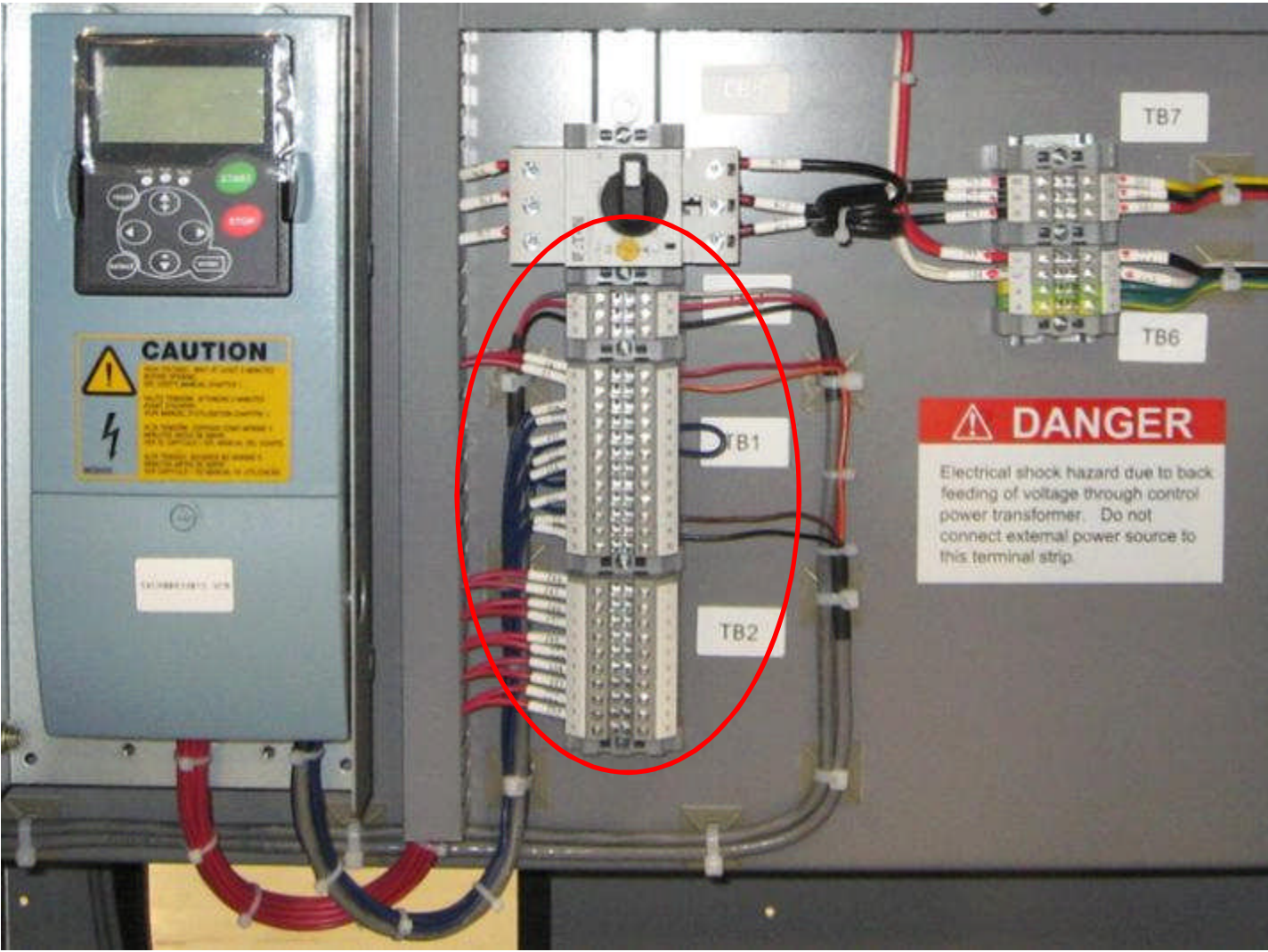

EATON LCX9000

Spare Safety



Turn to the Experts™

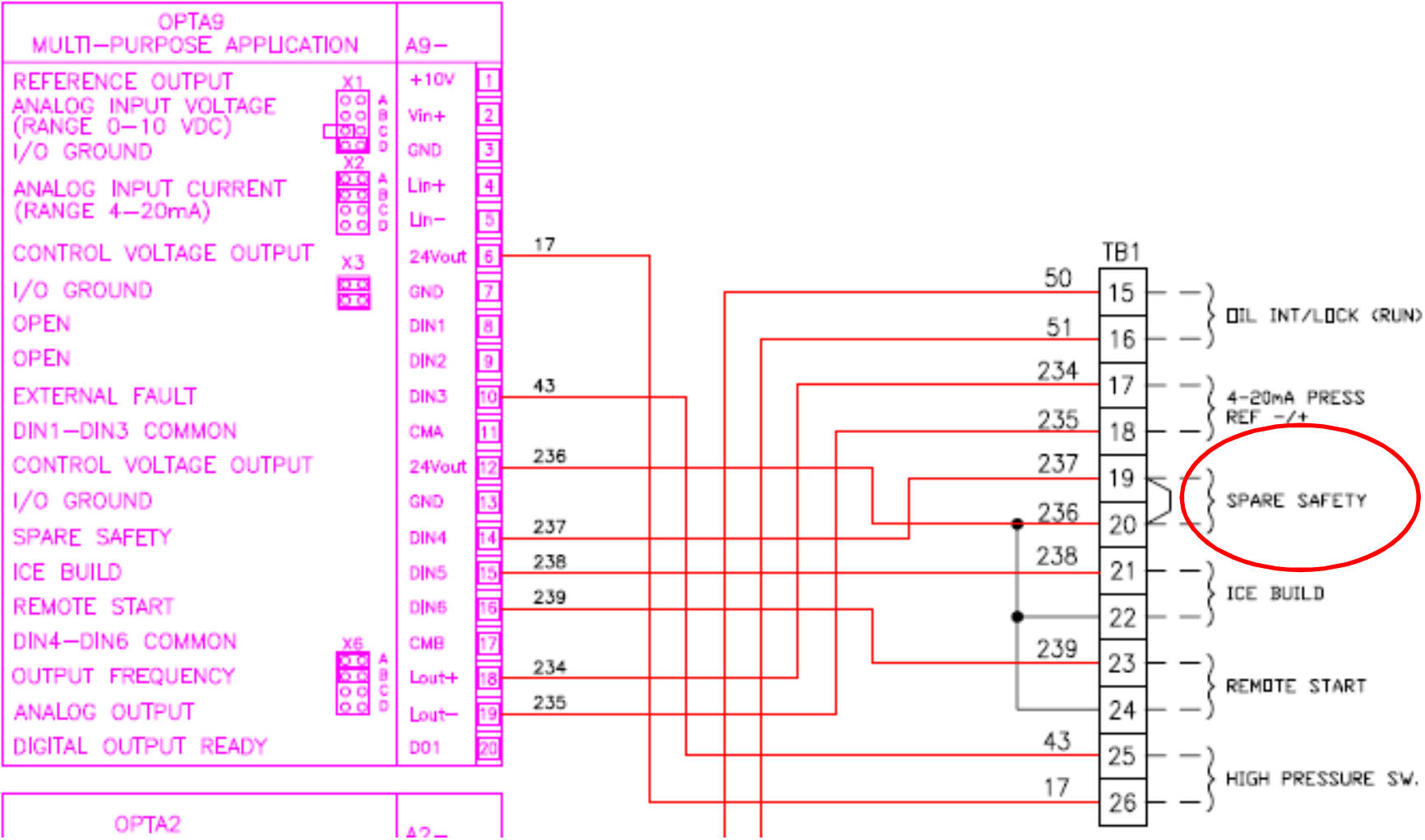

EATON LCX9000

Remote Start/Stop



Turn to the Experts™

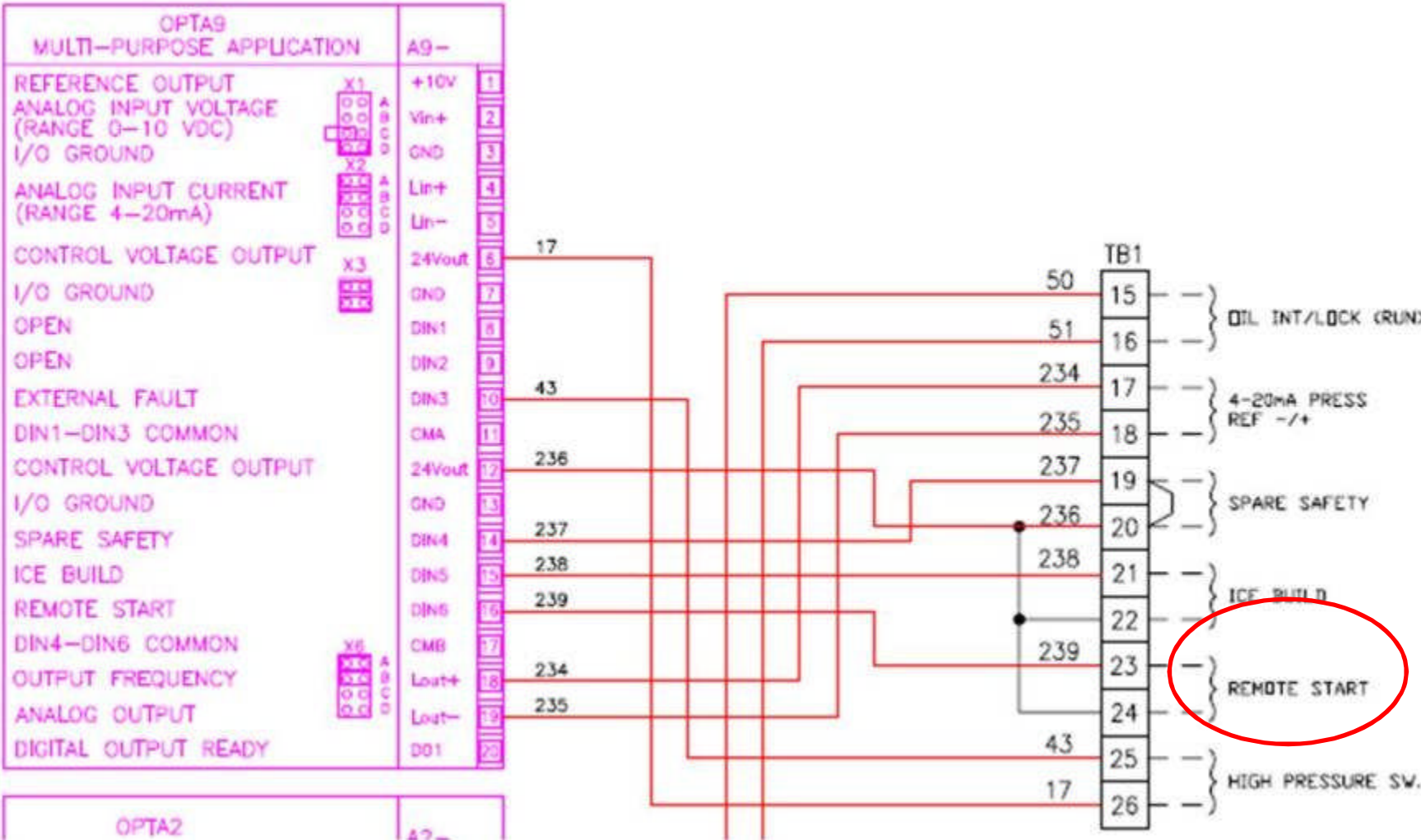

EATON LCX9000

Oil Pump Interlock



Turn to the Experts™

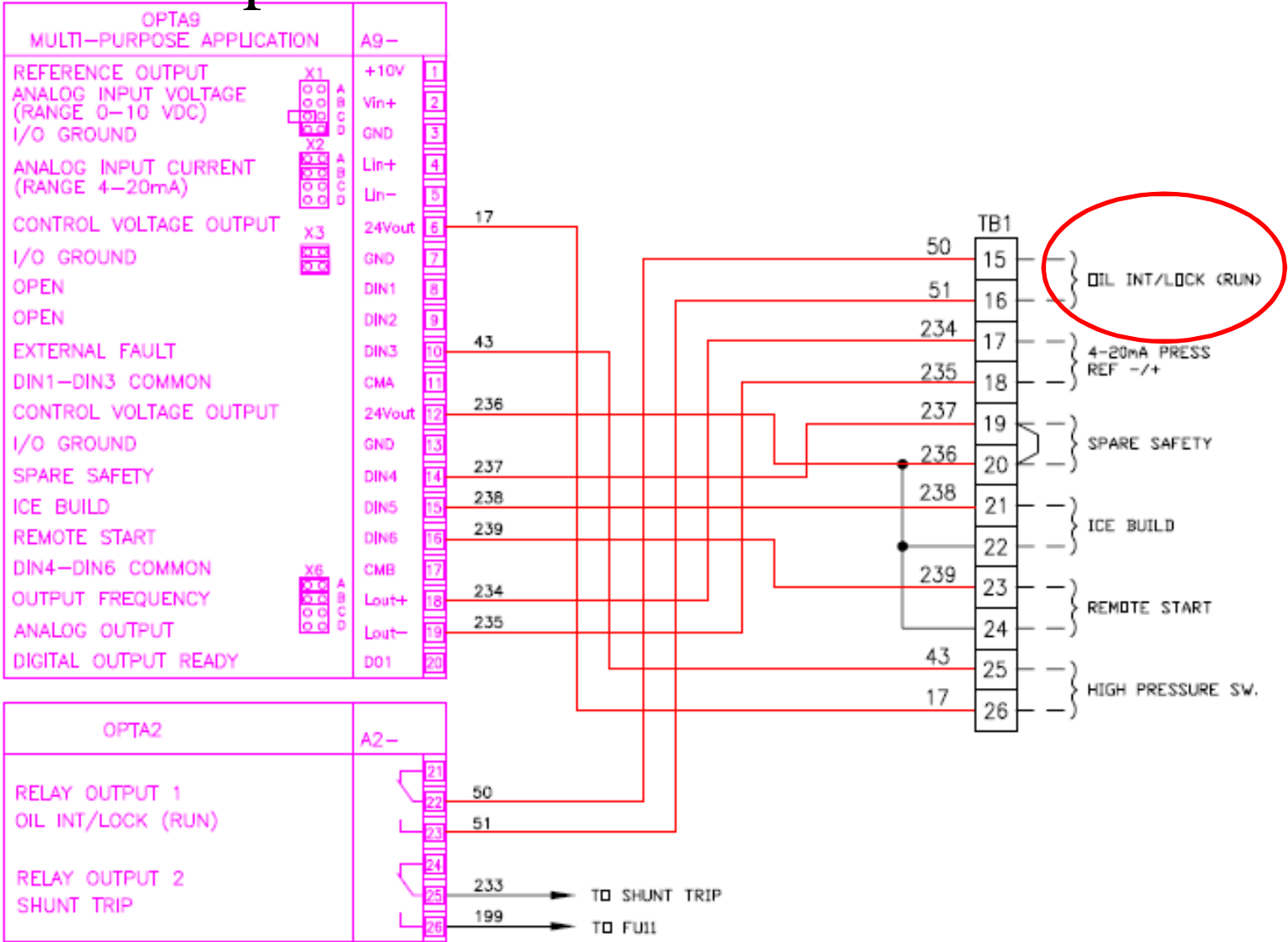

EATON LCX9000

Head Pressure Reference



Turn to the Experts™

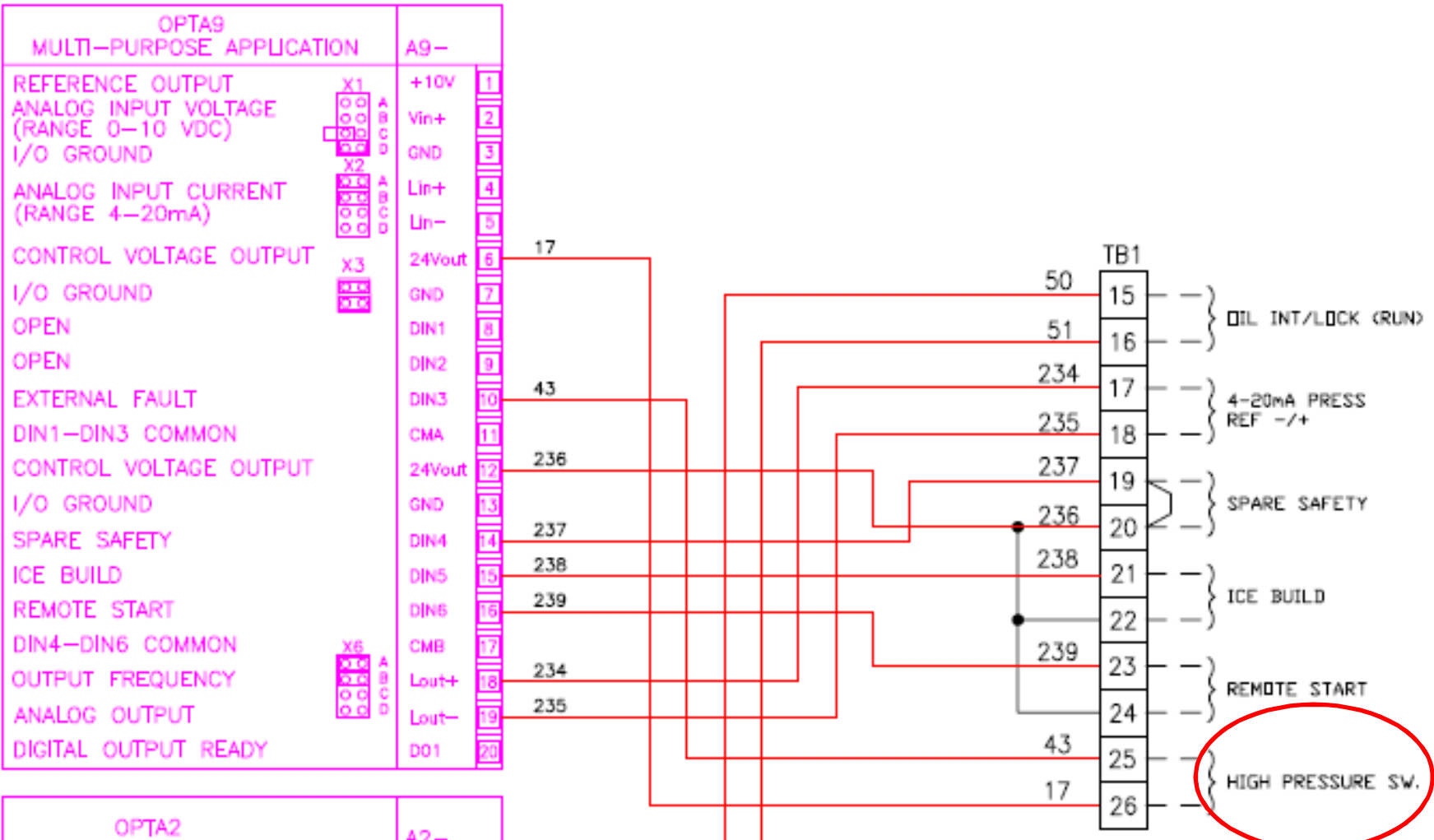

EATON LCX9000

Communication

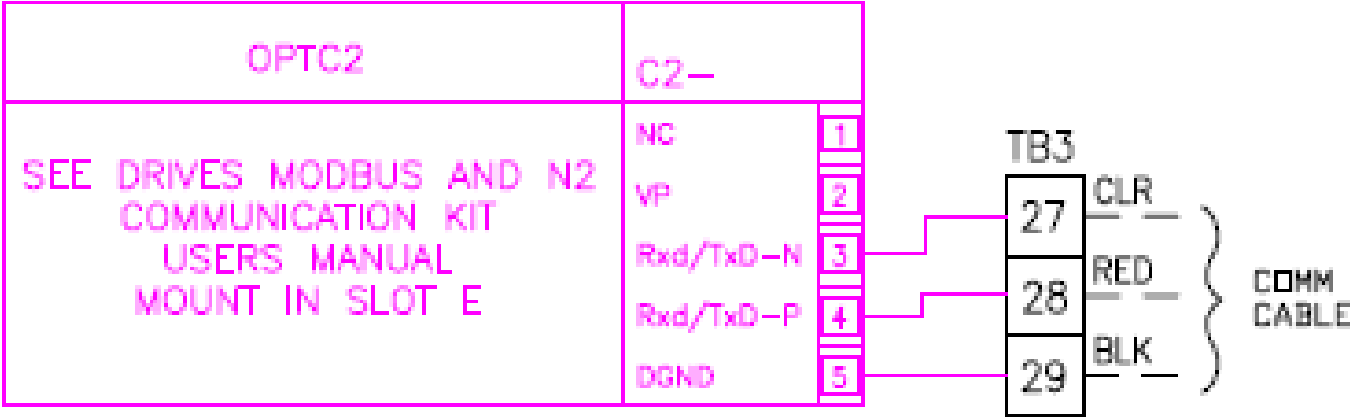

EATON LCX9000

Pump, Fan, Alarm



Turn to the Experts™

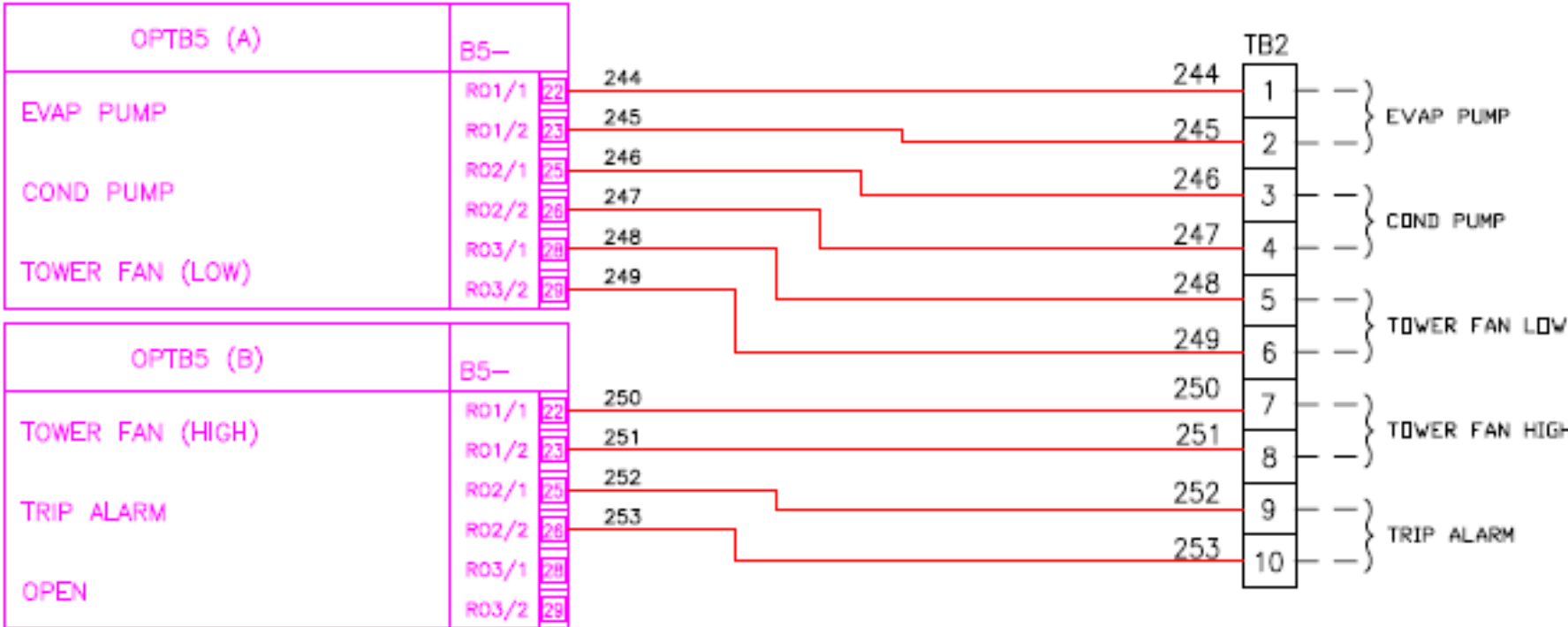

EATON LCX9000

Flow Switch



Turn to the Experts™

No Flow Switches

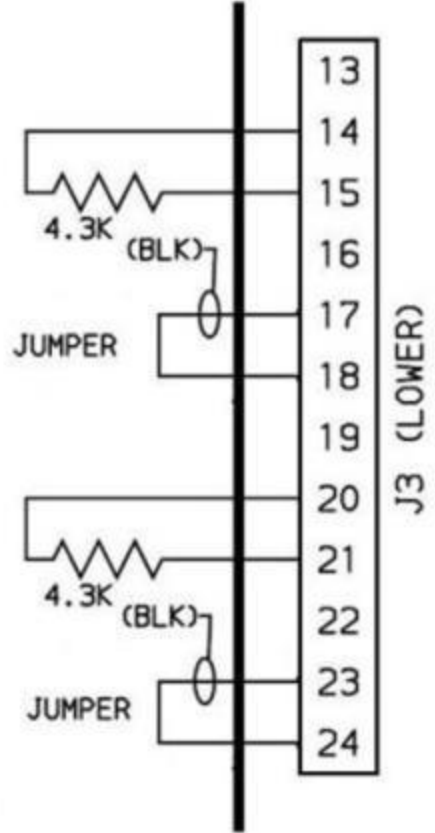

Optional Flow Switches

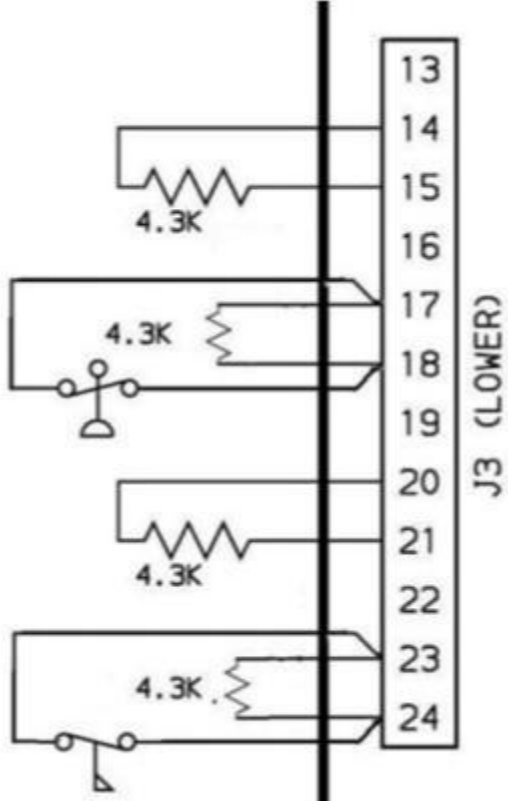

CCM

***These devices are not supported by*
the chiller warranty**

EATON LCX9000

OPTC2 Communication Board



Turn to the Experts™

OPTC2 Communication Board

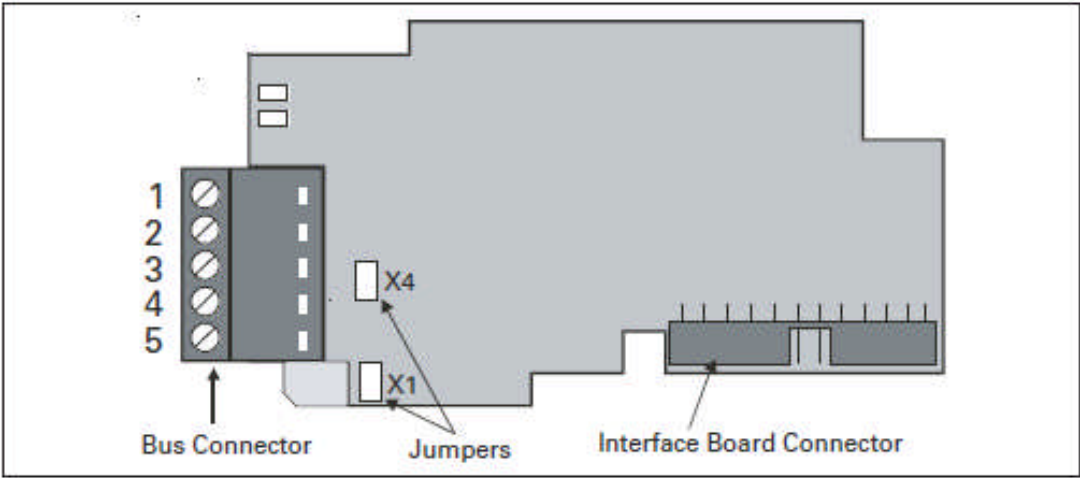
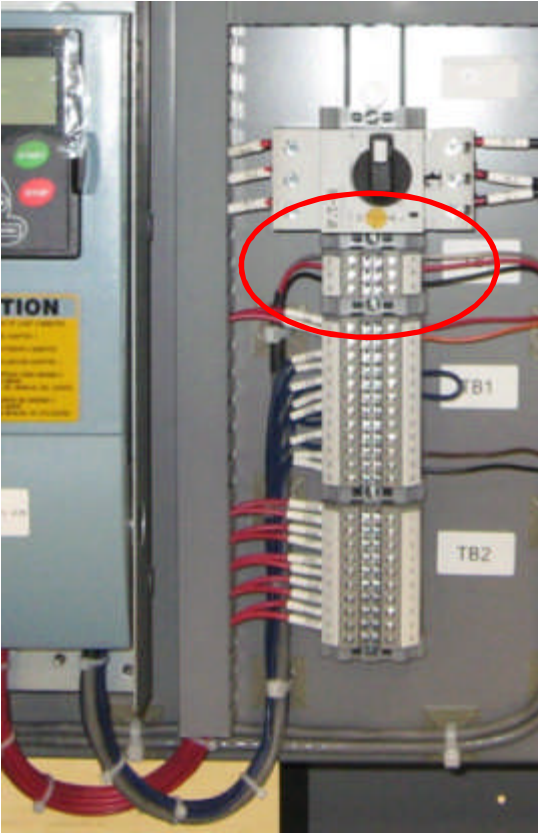



Figure 2-1: Option Board OPTC2 Communication Board

Table 2-1: OPTC2 Bus Connector Signals

Signal	Connector	Description
NC ⁽¹⁾	1 ⁽¹⁾	No connection
VP	2	Supply voltage – plus (5V)
R _x D/T _x D –N	3	Receive/Transmit data – minus (A)
R _x D/T _x D –P	4	Receive/Transmit data – plus (B)
DGND	5	Data ground (reference potential for VP)

⁽¹⁾ This pin (1) can be used to bypass the cable shield to the next slave.

- 
ON X4 jumper is the 120Ω termination resistor. Set X4 jumper to ON only if the Cutler-Hammer drive is the last device on the network.
- 
OFF X1 jumper has no effect on OPTC2 board. It is used on the OPTC8 board on the following page.

OPTC2 Communication Board



Bus Terminal Resistors

If the C2 or C8 Option Card is the last device on the network, the bus termination must be set to ON. Use jumper X4 (set to the ON position for termination). See **Figure 3-6**.

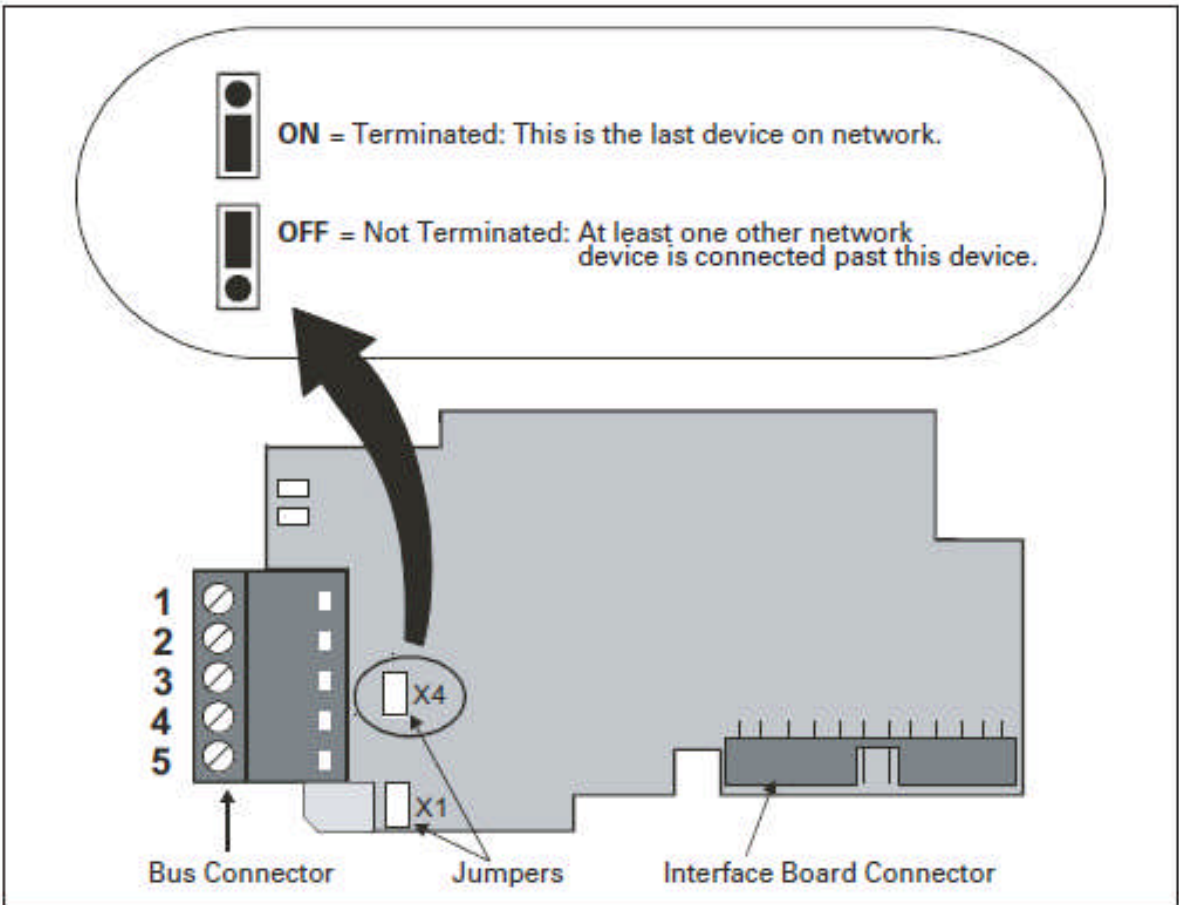

Figure 3-6: Using Jumper X4 to Set the Bus Termination

EATON LCX9000

OPTC2 Communication Board



Turn to the Experts™

LED Indications

The two LED indicators next to the connector show the present status of the Communication Board (yellow) and the Fieldbus Module (green).

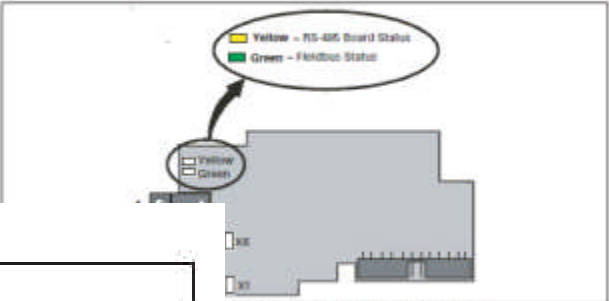

Table 3-2: Communication Board Status LED (BS) — YELLOW

LED is:	Meaning:
OFF	Option board not activated
ON	Option board in initialization state waiting for activation command from the Adjustable Frequency Drive (AFD)
Blinking fast (once/sec)	Option board is activated and in RUN state Option board is ready for external communication
Blinking slow (once/5 secs)	Option board is activated and in FAULT state Internal fault of option board

Table 3-3: Fieldbus Status LED (FS) — GREEN

LED is:	Meaning:
OFF	Fieldbus module is waiting for parameters from the AFD No external communication
ON	Fieldbus module is activated Parameters received and module activated Module is waiting for messages from the bus
Blinking fast (once/sec)	Module is activated and receiving messages from the bus
Blinking slow (once/5 secs)	Module is in FAULT state No messages from Master within the watchdog time Bus broken, cable loose or Master off-line

EATON LCX9000



Turn to the Experts.™

Startup

EATON LCX9000

Startup



19XRV-2SS Operation & Maintenance Manual

19XRV-4SS Operation & Maintenance Manual

19XRV-1SI Installation Manual

Reports Output of the design data sheet
(Minimum of 2 pages)

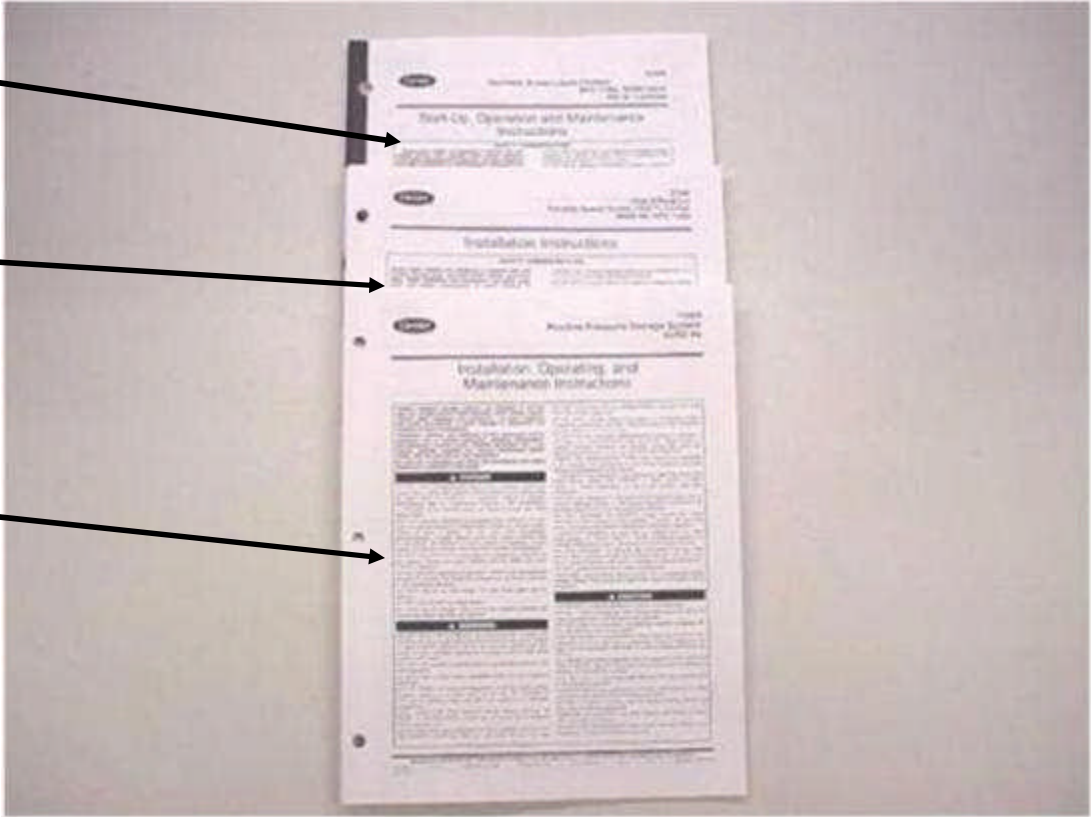

EATON LCX9000

Startup



Turn to the Experts™

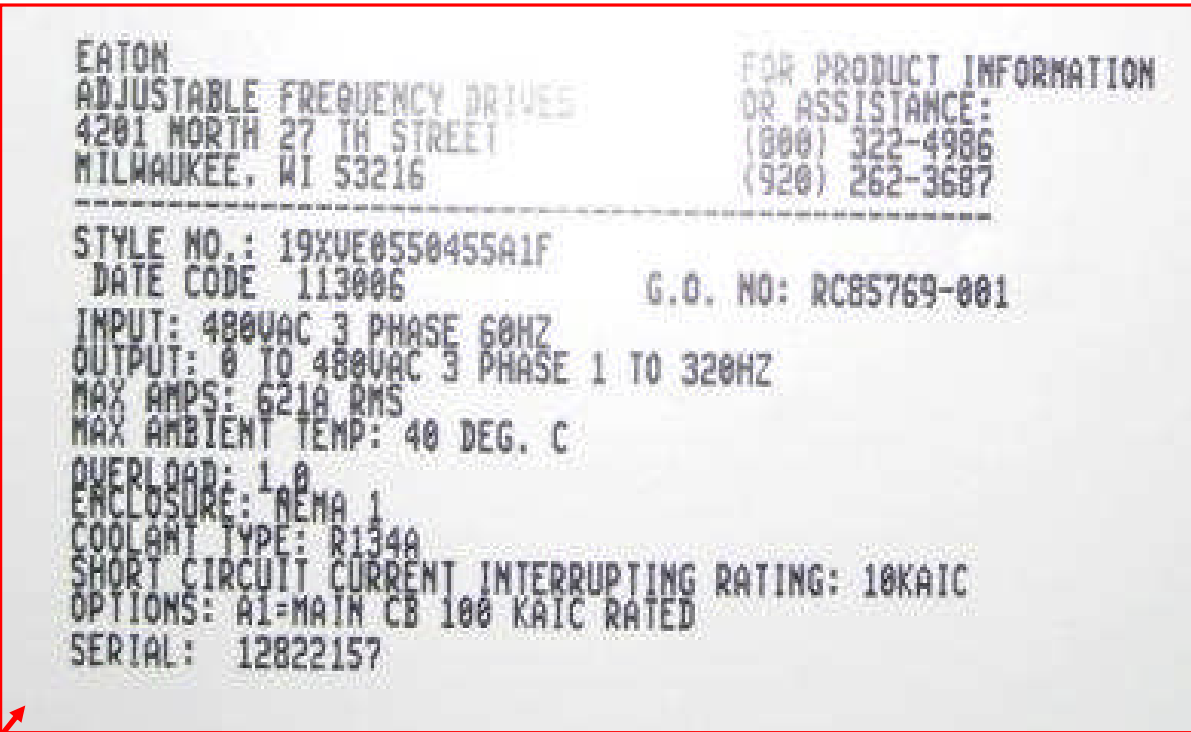
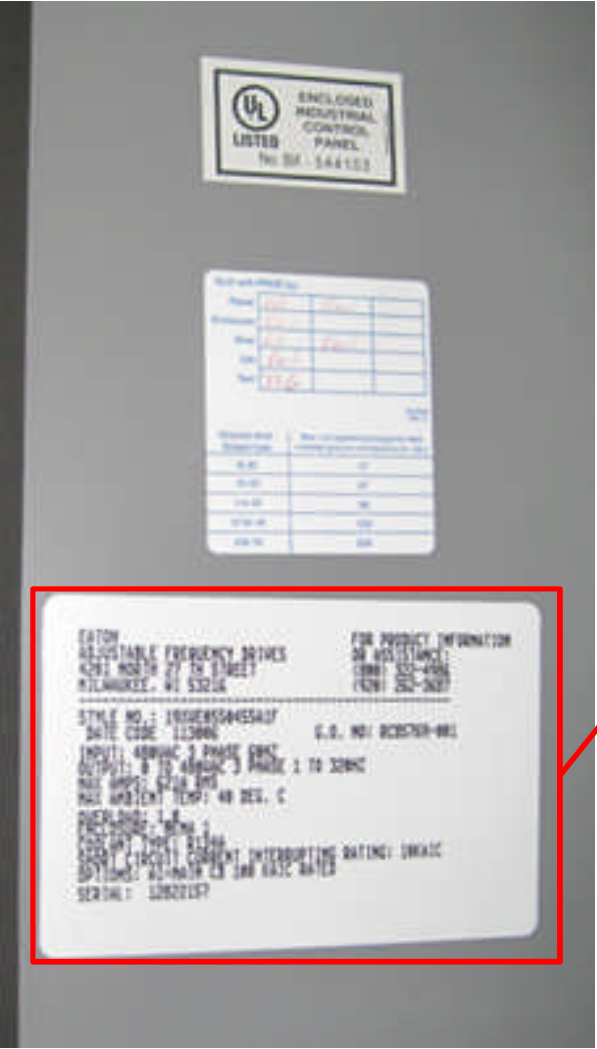

Record Drive info found on label
inside VFD Panel
Note Style No., Date Code, G.O. No.,
Max Amps

EATON LCX9000



Turn to the Experts.™

Commissioning: Record Job Info

 Carrier <small>A United Technologies Company</small>	
MODEL NUMBER	
SERIAL NUMBER	
MACHINE NAMEPLATE SUPPLY DATA	
VOLTS/PHASE/HERTZ	
LOCKED ROTOR AMPS	
OVERLOAD TRIP AMPS	
MAX FUSE/CIRCUIT BREAKER SIZE	
MIN SUPPLY CIRCUIT CAPACITY	
MACHINE ELECTRICAL DATA	
MOTOR NAMEPLATE VOLTAGE	
COMPRESSOR 100% SPEED	
RATED LINE VOLTAGE	
RATED LINE AMPS	
RATED LINE KILOWATTS	
MOTOR RATED LOAD KW	
MOTOR RATED LOAD AMPS	
MOTOR NAMEPLATE AMPS	
MOTOR NAMEPLATE RPM	
MOTOR NAMEPLATE KW	
INTERFER PWM FREQUENCY	

Verify Installation — Record the following job information:

1. Job Name
2. Job Number
3. City
4. State
5. Zip Code

Record the following nameplate information:

1. From the VFD nameplate:
 - a. VFD Serial Number
 - b. VFD Part Number
2. From the machine nameplate (Fig. 4) located inside the VFD enclosure:
 - a. Chiller Serial Number
 - b. Chiller Model
 - c. Motor rated load amps
 - d. Motor nameplate rpm
 - e. Motor nameplate kW
 - f. Motor nameplate voltage
 - g. IPWM (pulse width modulation) frequency
 - h. Voltage
3. From the ICVC control panel screen:
 - a. Carrier Part Number and Revision
 - b. ICVC Software Number

EATON LCX9000

Startup



 Carrier <small>A United Technologies Company</small>	
MODEL NUMBER	
SERIAL NUMBER	
MACHINE NAMEPLATE SUPPLY DATA	
VOLTS/PHASE/HERTZ	
LOCKED ROTOR AMPS	
OVERLOAD TRIP AMPS	
MAX FUSE/CIRCUIT BREAKER SIZE	
MIN SUPPLY CIRCUIT CAPACITY	
MACHINE ELECTRICAL DATA	
MOTOR NAMEPLATE VOLTAGE	
COMPRESSOR 100% SPEED	
RATED LINE VOLTAGE	
RATED LINE AMPS	
RATED LINE KILOWATTS	
MOTOR RATED LOAD KW	
MOTOR RATED LOAD AMPS	
MOTOR NAMEPLATE AMPS	
MOTOR NAMEPLATE RPM	
MOTOR NAMEPLATE KW	
INVERTER PWM FREQUENCY	
<small>SAFETY CODE CERTIFICATION</small> <small>THE COMPRESSOR MOTOR CONTROLLER AND OVERLOAD PROTECTION MUST BE</small> <small>IN ACCORDANCE WITH CARRIER SPECIFICATION 1-426.</small>	
<small>19XRS000701 REV. 3</small>	

Located on inside of VFD enclosure door

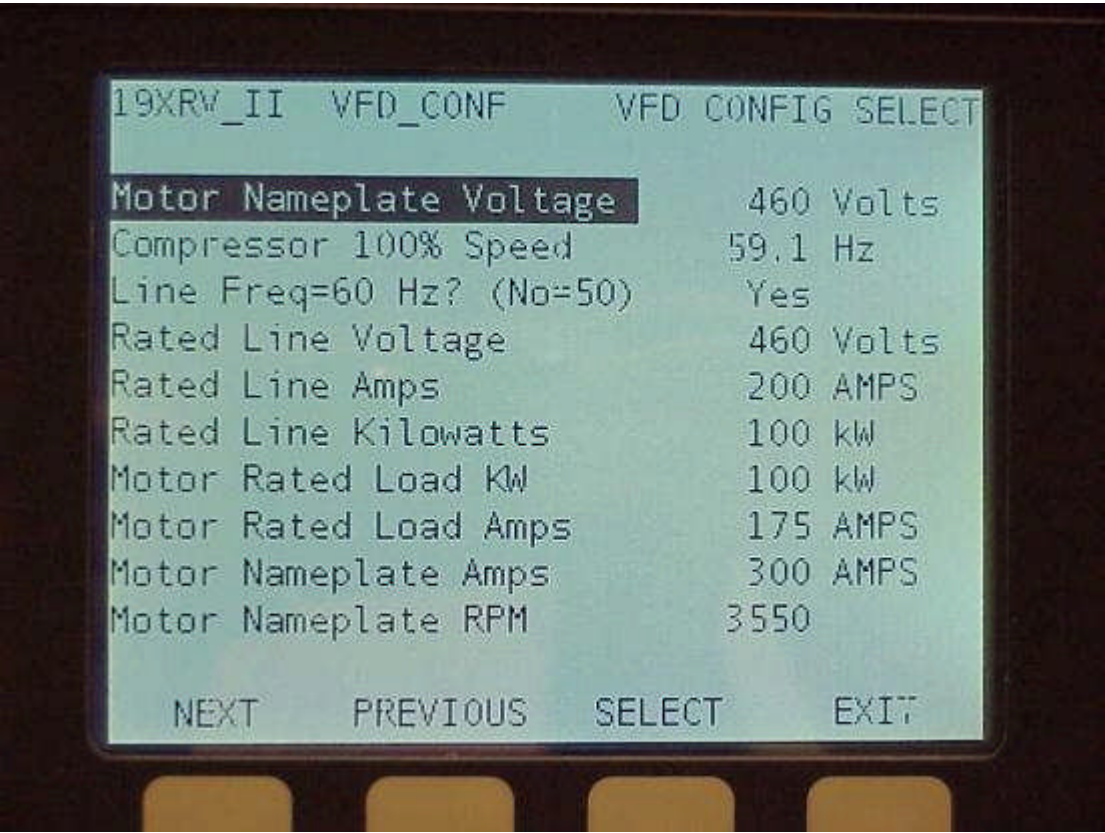
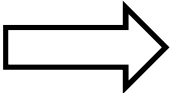

EATON LCX9000

VFD Config Setting



Turn to the Experts™

Correct Label

Carrier
A United Technologies Company
MODEL NUMBER 19XRV5050446LCH64-
SERIAL NUMBER 2911Q21017

MACHINE NAMEPLATE SUPPLY DATA	
VOLTS/PHASE/HERTZ	460 / 3 / 60
LOCKED ROTOR AMPS	454
OVERLOAD TRIP AMPS	490.32
MAX FUSE/CIRCUIT BREAKER SIZE	1000
MIN SUPPLY CIRCUIT AMPACITY	567

MACHINE ELECTRICAL DATA	
MOTOR NAMEPLATE VOLTAGE	460 V
COMPRESSOR 100% SPEED	60
RATED LINE VOLTAGE	460
RATED LINE AMPS	454
RATED LINE KILOWATTS	335
MOTOR RATED LOAD KW	325
MOTOR RATED LOAD AMPS	522
MOTOR NAMEPLATE AMPS	545
MOTOR NAMEPLATE RPM	3567
MOTOR NAMEPLATE KW	387
INVERTER PWM FREQUENCY	4 KHZ

Carrier
A United Technologies Company
MODEL NUMBER 19XRV4242388KPH64-
SERIAL NUMBER 3011Q21000

MACHINE ELECTRICAL DATA	
LINE SIDE	
VOLTAGE	460
PHASE	3
HZ	60
CHILLER FL AMPS	387
MAX. FUSE/CIRCUIT BREAKER	800
MIN. CKT AMPACITY	484
LOAD SIDE	
VOLTAGE	460
PHASE	3
HZ	60
MOTOR FLA	442
MOTOR LRA	2082



Wrong Label

EATON LCX9000

VFD Config Setting



Turn to the Experts™

Carrier A United Technologies Company	
MODEL NUMBER 19XRV5050446LCH64-	
SERIAL NUMBER 2911Q21017	
MACHINE NAMEPLATE SUPPLY DATA	
VOLTS/PHASE/HERTZ	460 / 3 / 60
LOCKED ROTOR AMPS	454
OVERLOAD TRIP AMPS	490.32
MAX FUSE/CIRCUIT BREAKER SIZE	1000
MIN SUPPLY CIRCUIT AMPACITY	567
MACHINE ELECTRICAL DATA	
MOTOR NAMEPLATE VOLTAGE	460 V
COMPRESSOR 100% SPEED	60
RATED LINE VOLTAGE	460
RATED LINE AMPS	454
RATED LINE KILOWATTS	335
MOTOR RATED LOAD KW	325
MOTOR RATED LOAD AMPS	522
MOTOR NAMEPLATE AMPS	545
MOTOR NAMEPLATE RPM	3567
MOTOR NAMEPLATE KW	387
INVERTER PWM FREQUENCY	4 KHZ

Check VFD Config Setting in ICVC (Service→VFD Config)

Make sure that Compressor 100% speed = 60 Hz

Rated Line Voltage, Amps and KW -- incoming side of VFD at 100% capacity

Motor Rated Load KW, Amps – measured on the output of VFD or at motor at 100% capacity

Motor Nameplate Amps, APM, KW – nameplate info of Motor at 100% capacity

PWM for LCX9000 drives Frame CH72,63 & 74 = 4Khz

EATON LCX9000

VFD Config



Turn to the Experts™

Motor Nameplate Voltage	460 Volts
Compressor 100% Speed	60.0 Hz
Line Freq=60 Hz? (No=50)	Yes
Rated Line Voltage	460 Volts
Rated Line Amps	291 AMPS
Rated Line Kilowatts	213 kW
Motor Rated Load kW	205 kW
Motor Rated Load Amps	330 AMPS
Motor Nameplate Amps	340 AMPS
Motor Nameplate RPM	3560

NEXT PREVIOUS SELECT EXIT

EATON LCX9000



Turn to the Experts™

Consistent Liquid Temperatures

Entering and Leaving Liquid Temperatures should be close when the water pumps are on but the compressor is not running

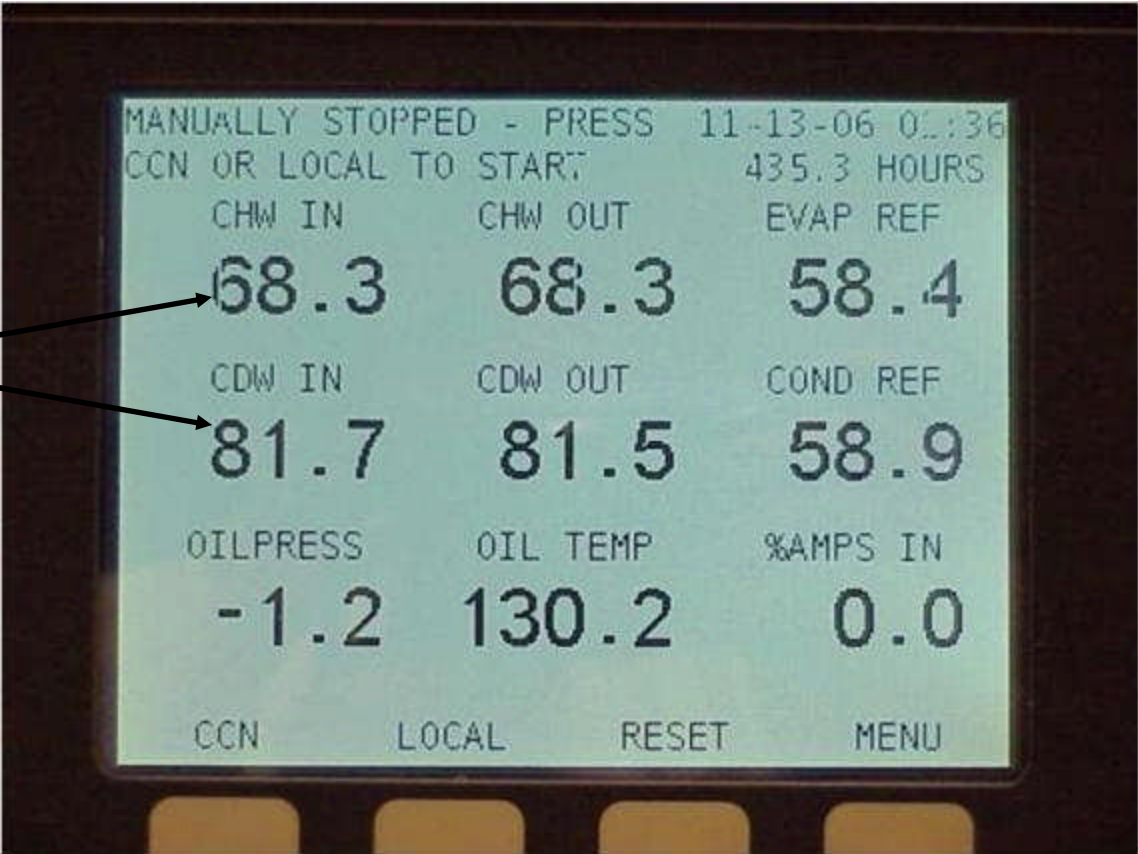

EATON LCX9000



Consistent Refrigerant Temperature

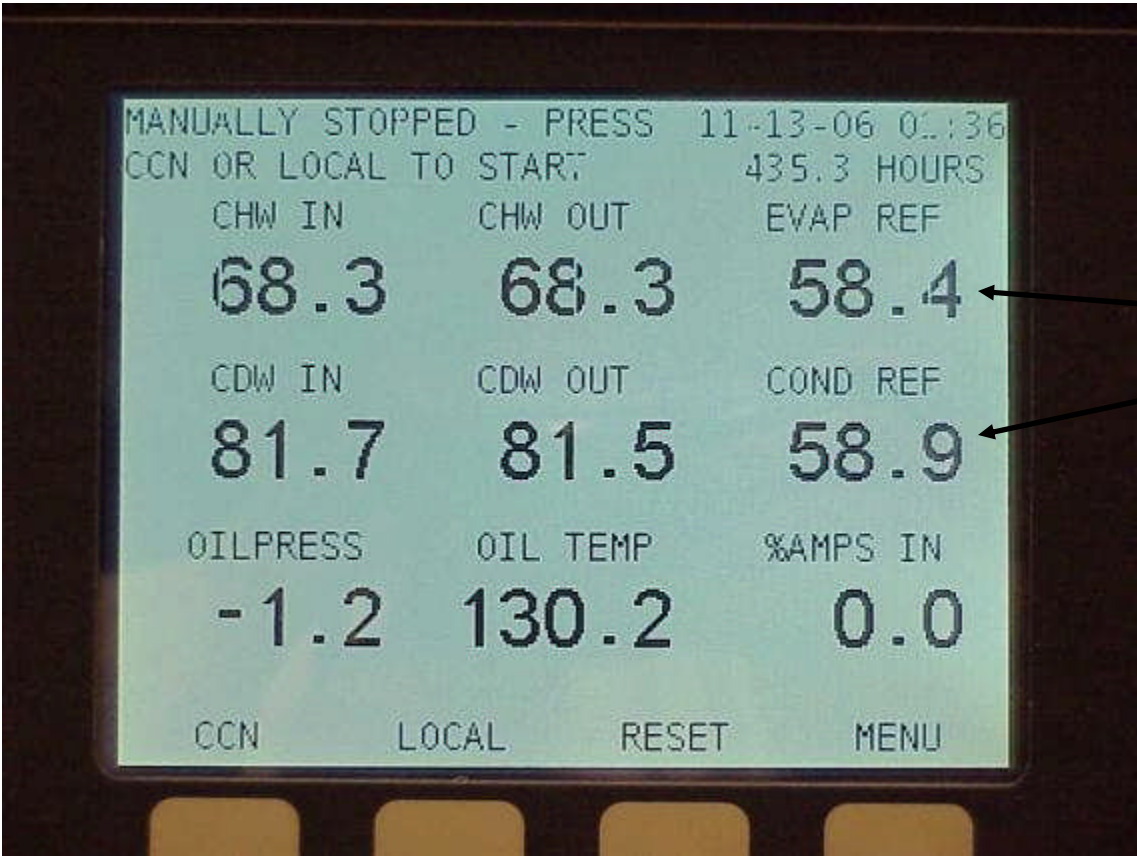

Refrigerant
Temperatures should be
close when the Isolation
Valves are open, the
Water Temperatures are
stable, and the Chiller is
not running

EATON LCX9000



Turn to the Experts.™

Perform Control Test

Pumps: Carrier Controls must be able to independently energize the Cooler and Condenser Liquid Pumps for Freeze Protection

Discrete Outputs: Cycles Oil Heater Relay, HGBP, Alarm Relay, VFD Cooling Solenoid, and Shunt Trip

Head Pressure Output: 4-20 mA

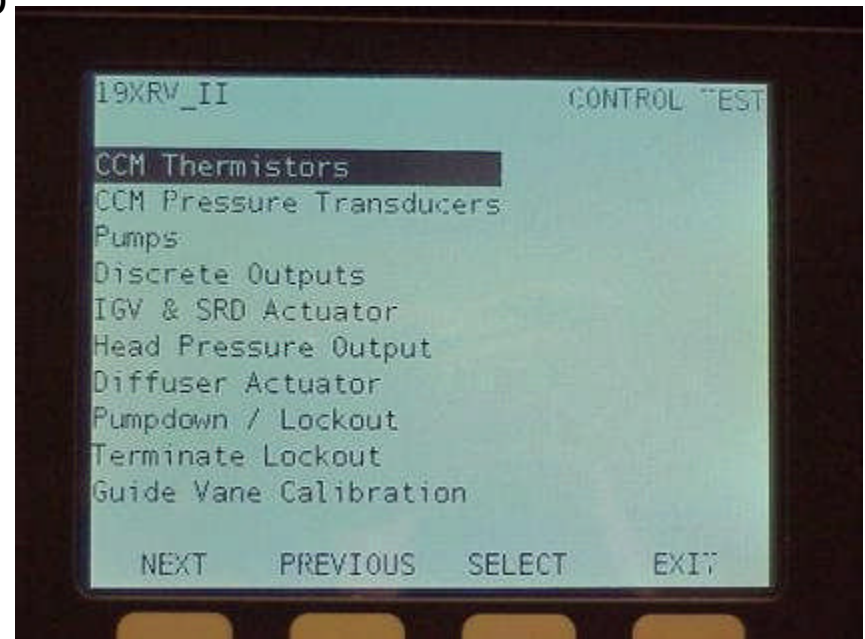

Perform Guide Vane Calibration

EATON LCX9000

Check ICVC Software versions

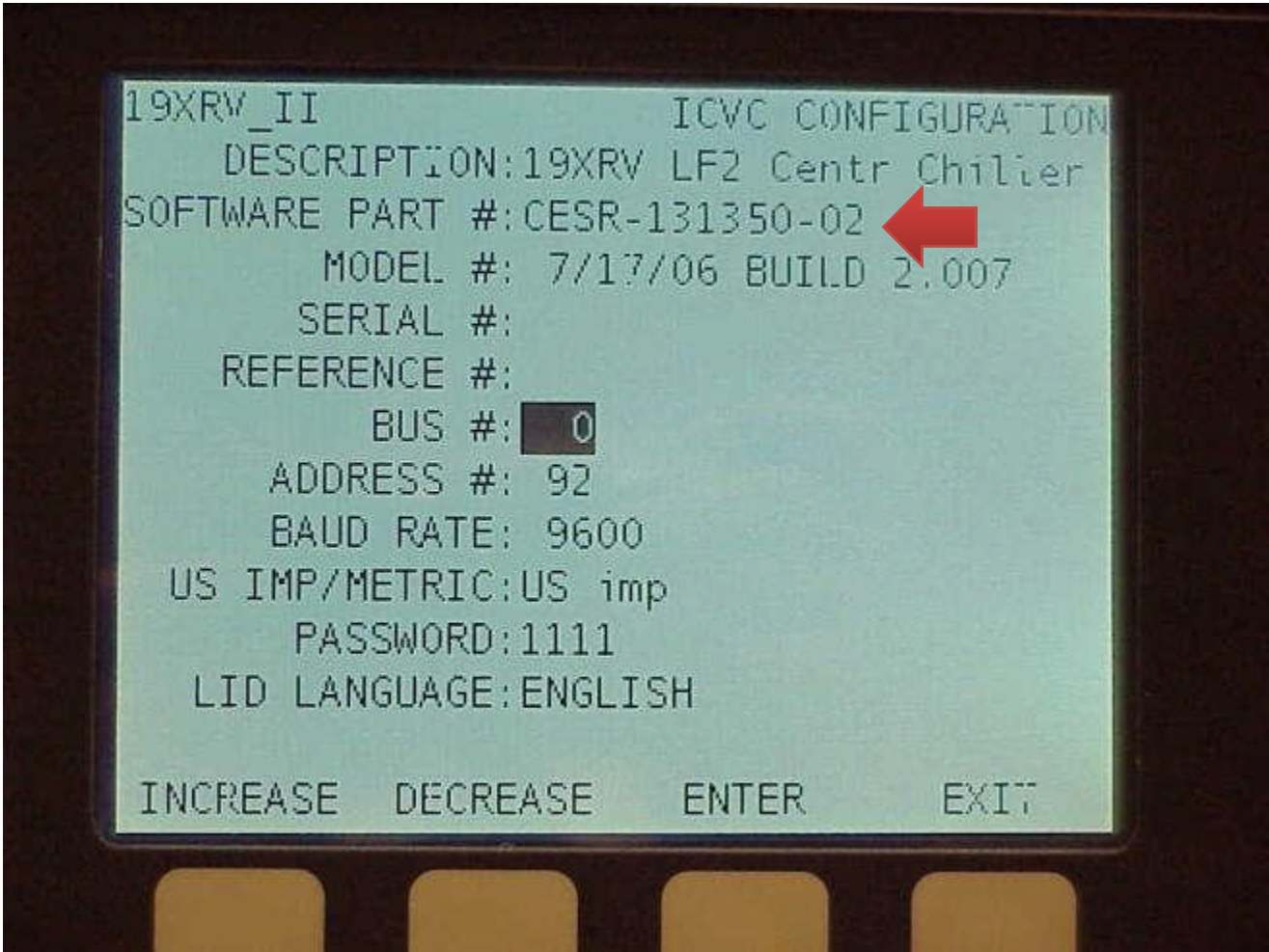

ICVC Software Version in ICVC Configuration Screen

EATON LCX9000



Turn to the Experts™

Check Condensation

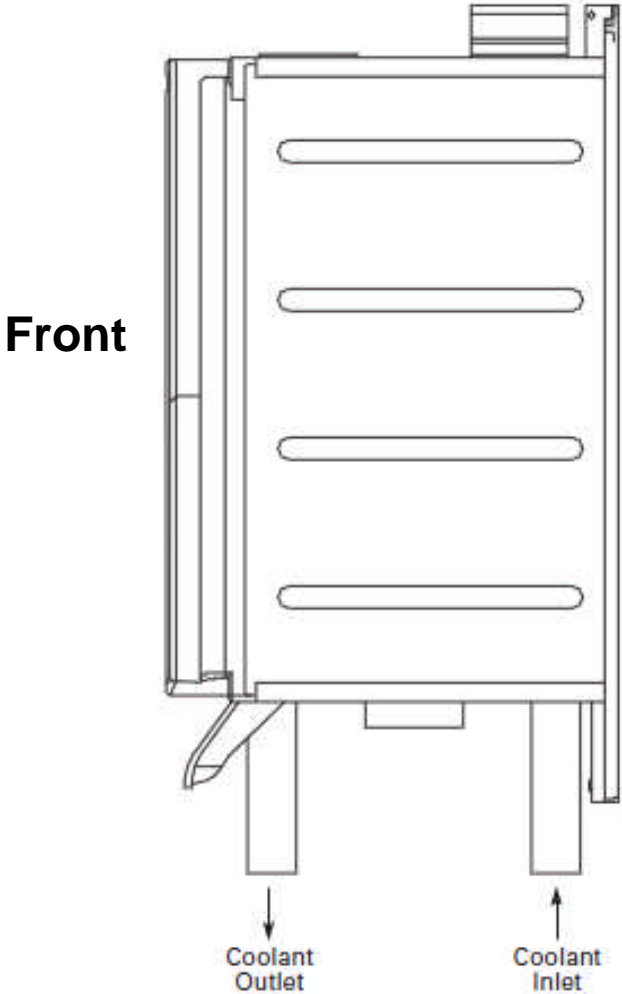

If the refrigerant line leaving the power module has condensation on it, it will require adjustment from full open towards closed to establish a refrigerant temperature of 80-90 deg f under full load conditions

EATON LCX9000



Additional Statup Check list

- Zero Transducers
- Calibrate Guide Vane
- Check ICVC configuration for
 - VFD Config
 - Surge/HGBP settings (Equipment service → Options)
 - Thrust bearing reset factory is set to 1.2~1.4 (Equipment service → Setup1)
 - VFD control setup (Equipment service → setup 2)
 - VFD Encl temp correction is set to -2.5 (Equipment service → Setup2)
- VFD Cooling lines to ensure that refrigerant temperature is not too cold