

Copyright Carrier Corp. 2003

3.

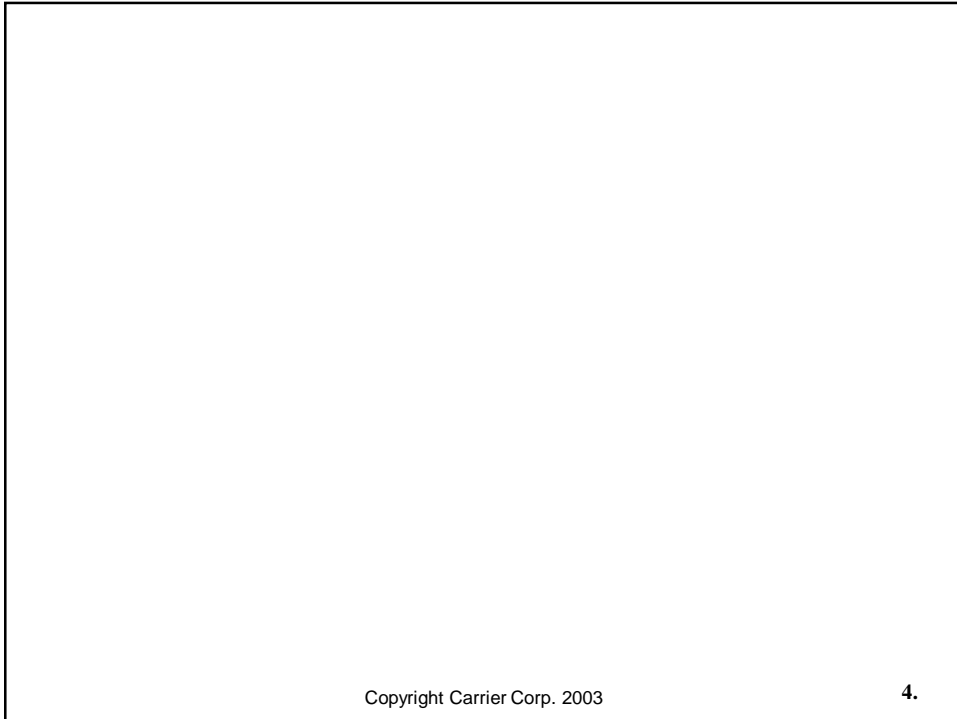

Copyright Carrier Corp. 2003

4.

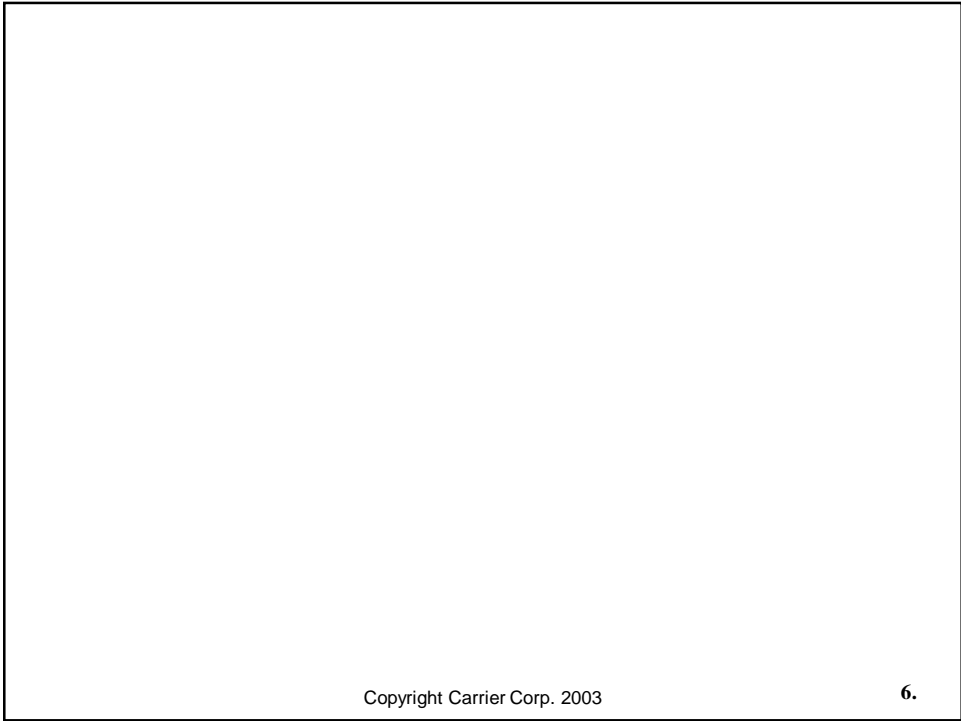
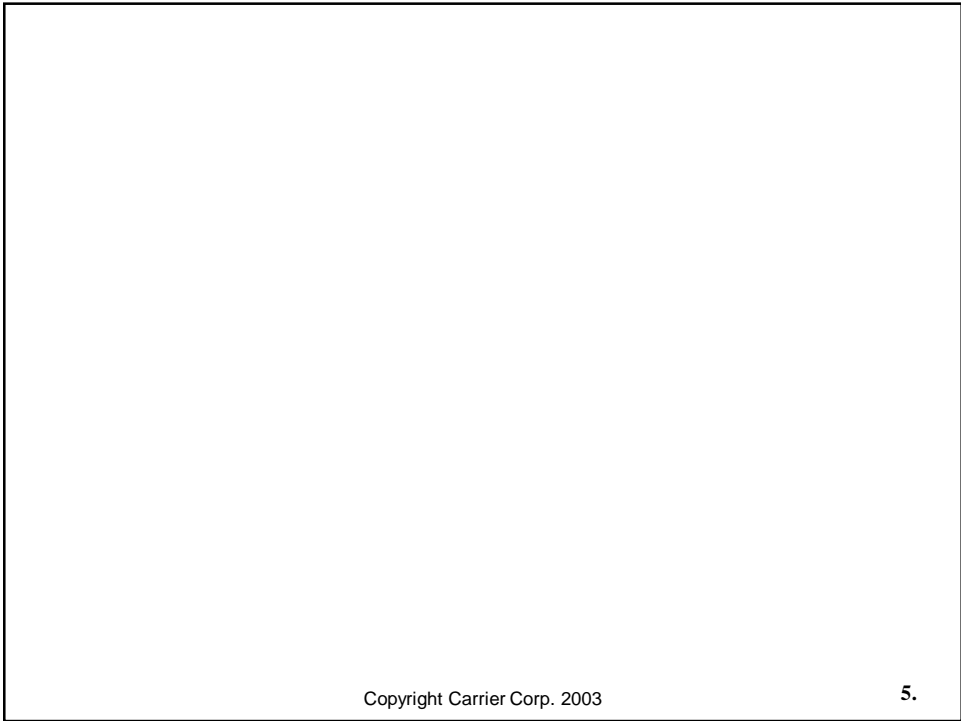

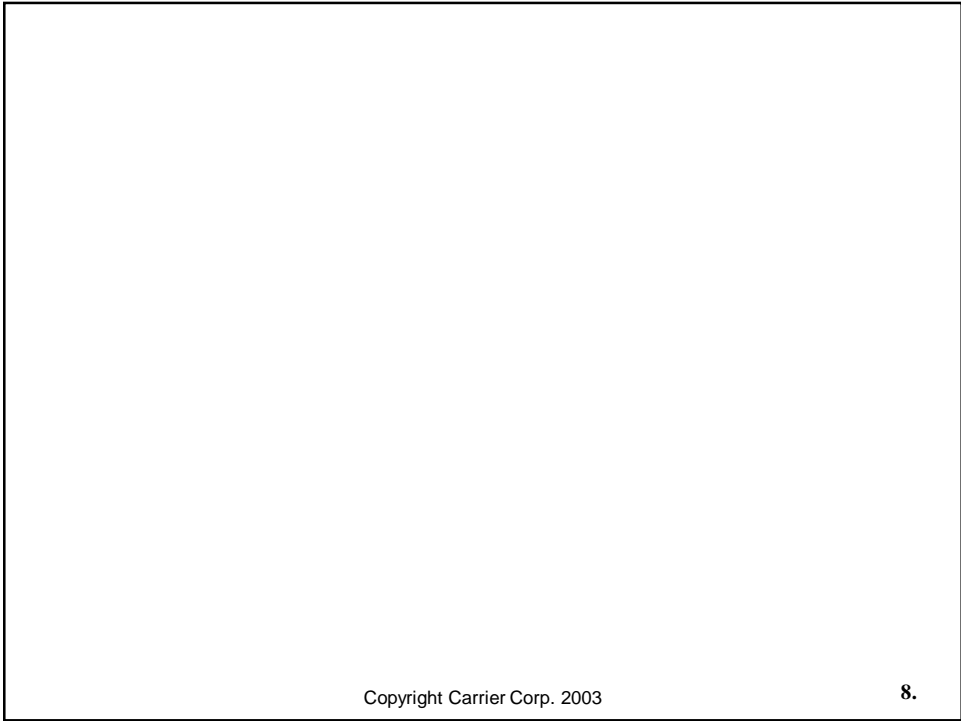
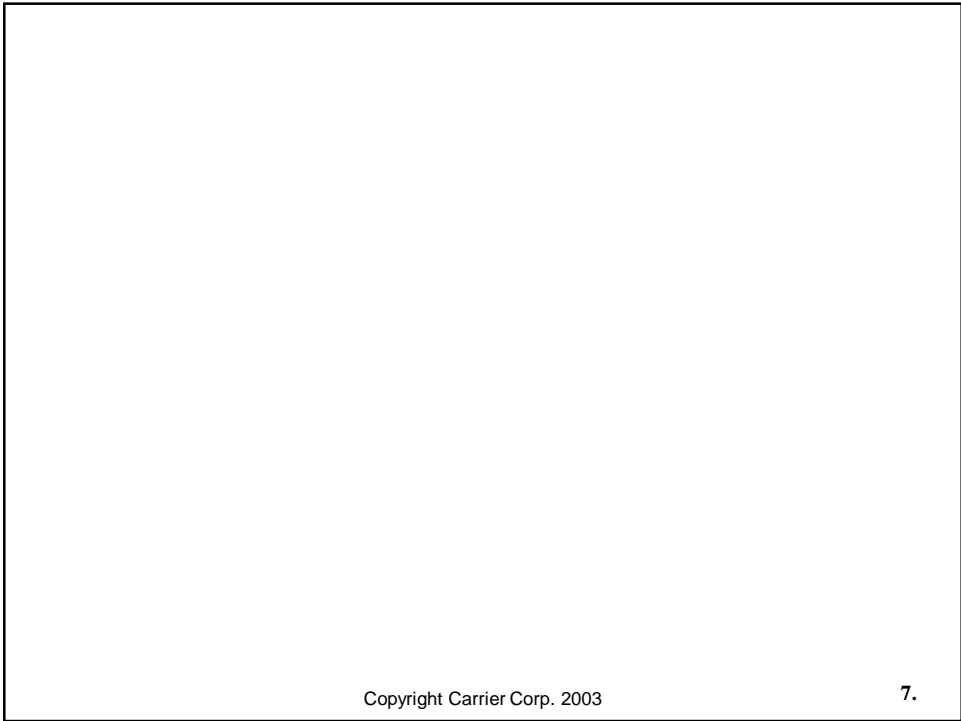

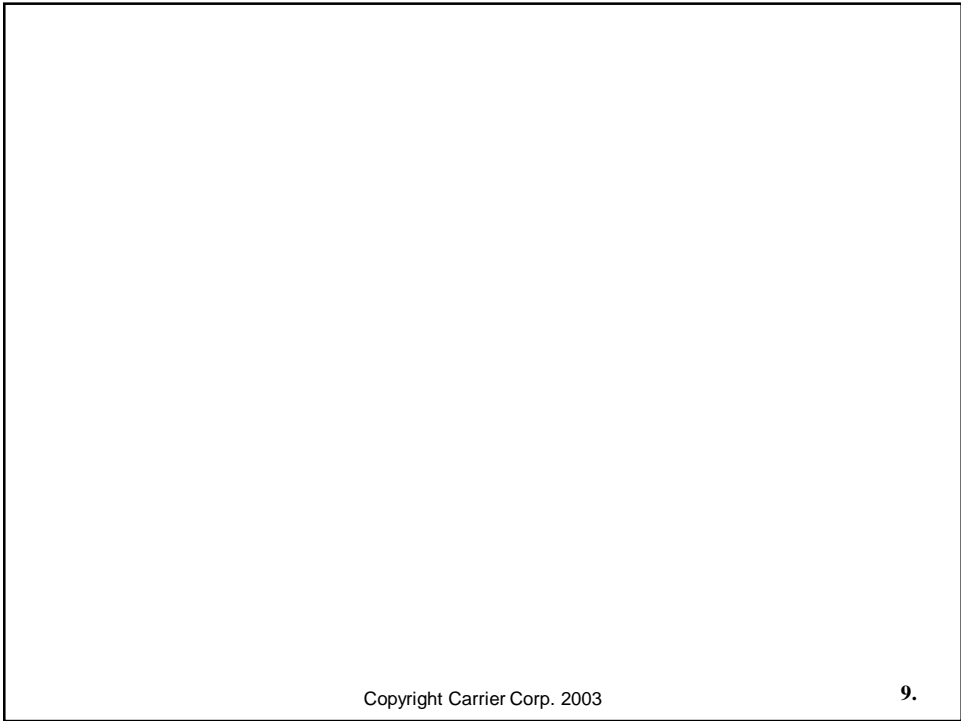

Copyright Carrier Corp. 2003

9.

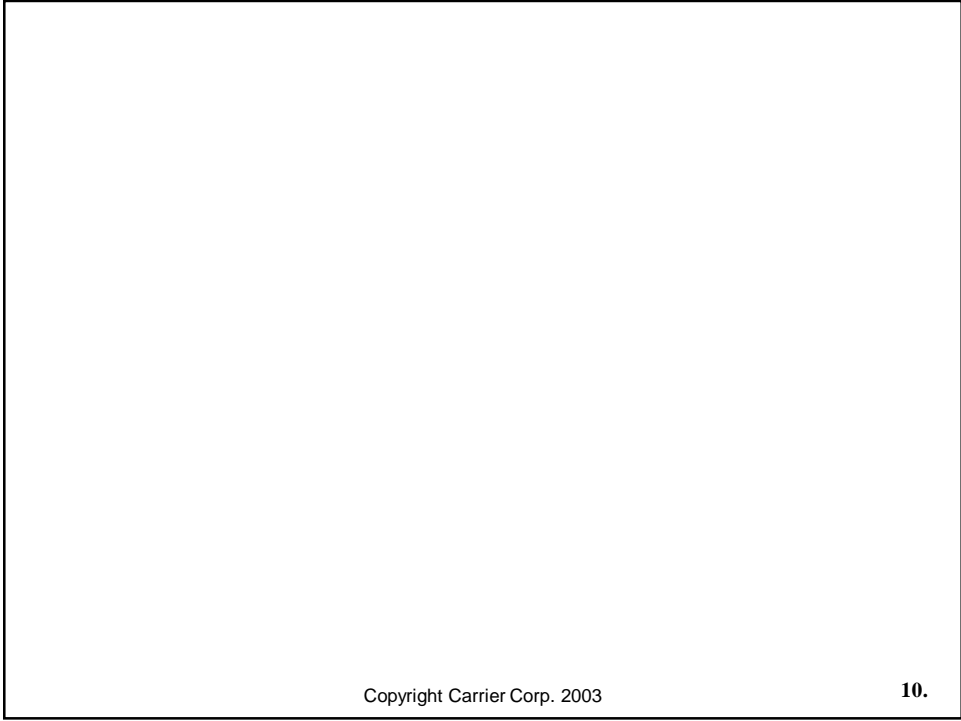

Copyright Carrier Corp. 2003

10.

# 23XR Screw Liquid Chiller



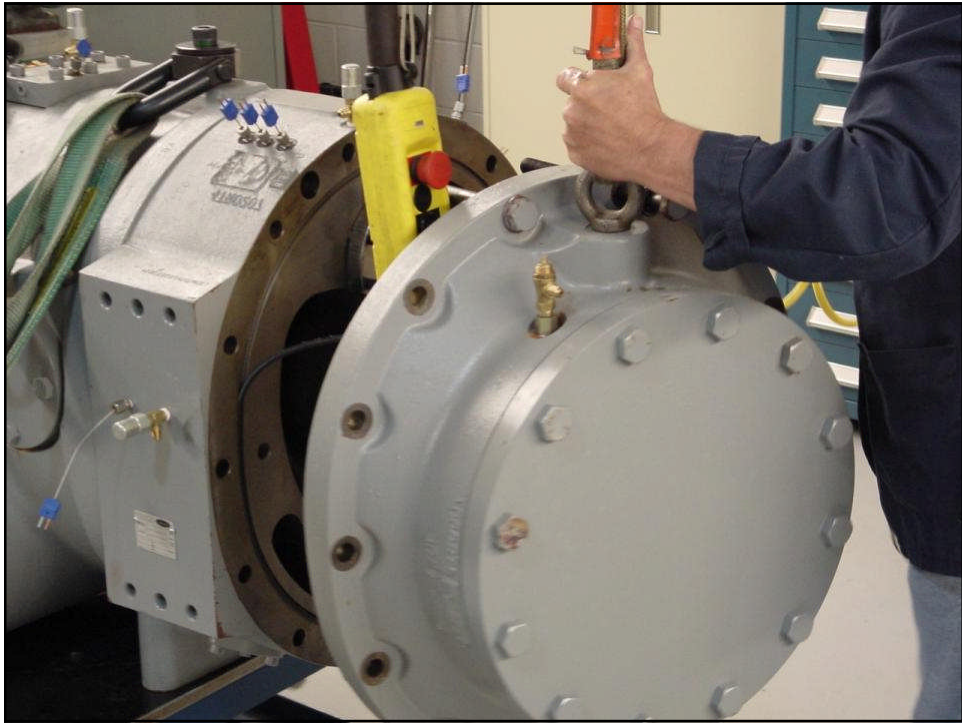



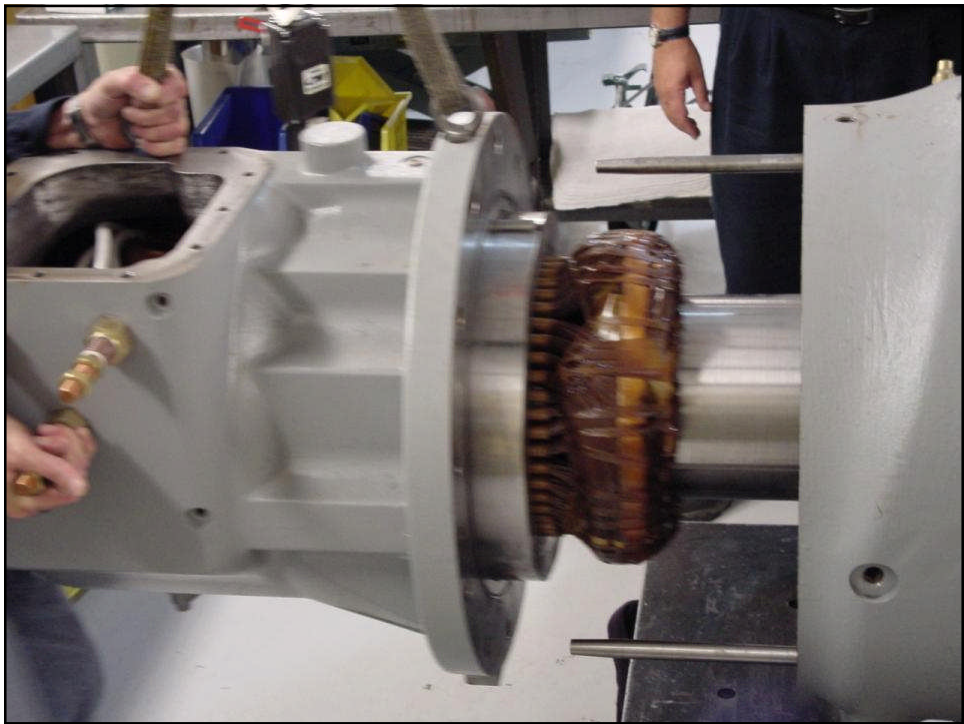
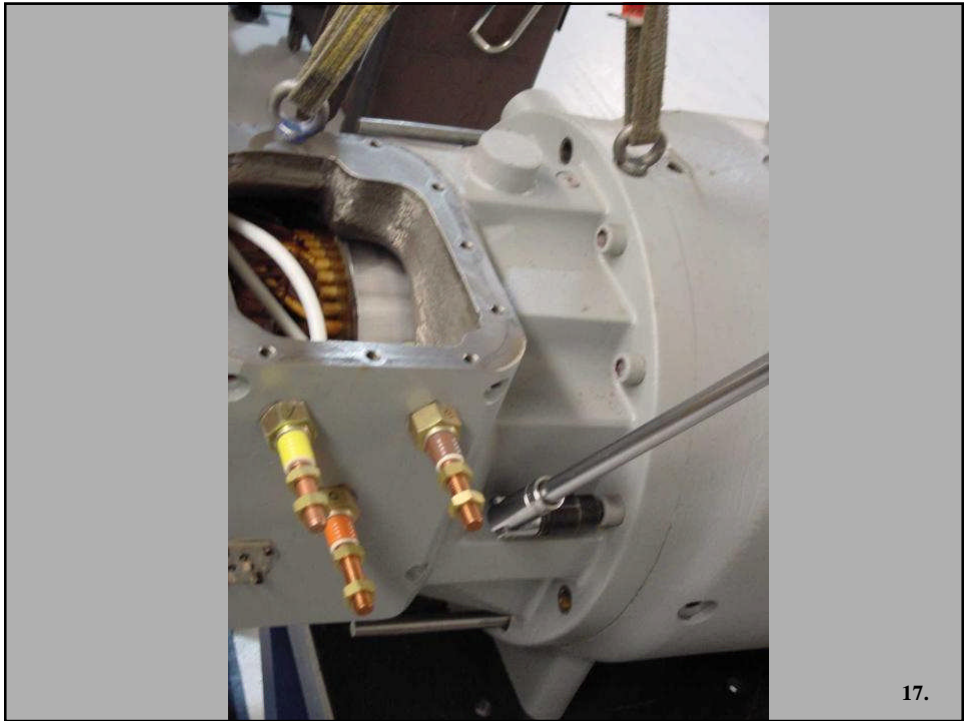

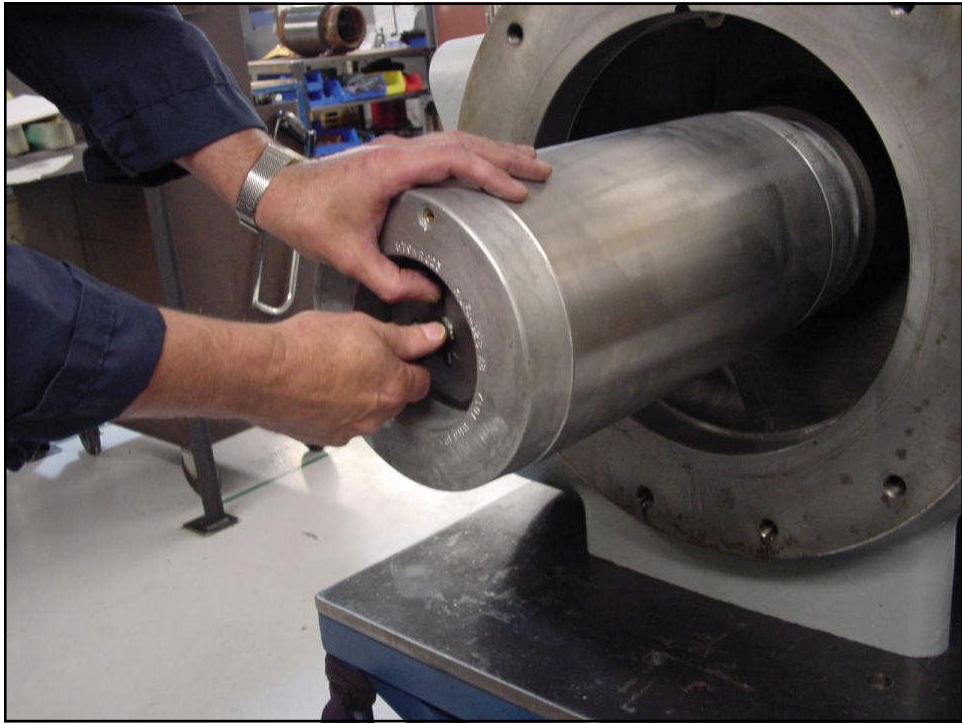

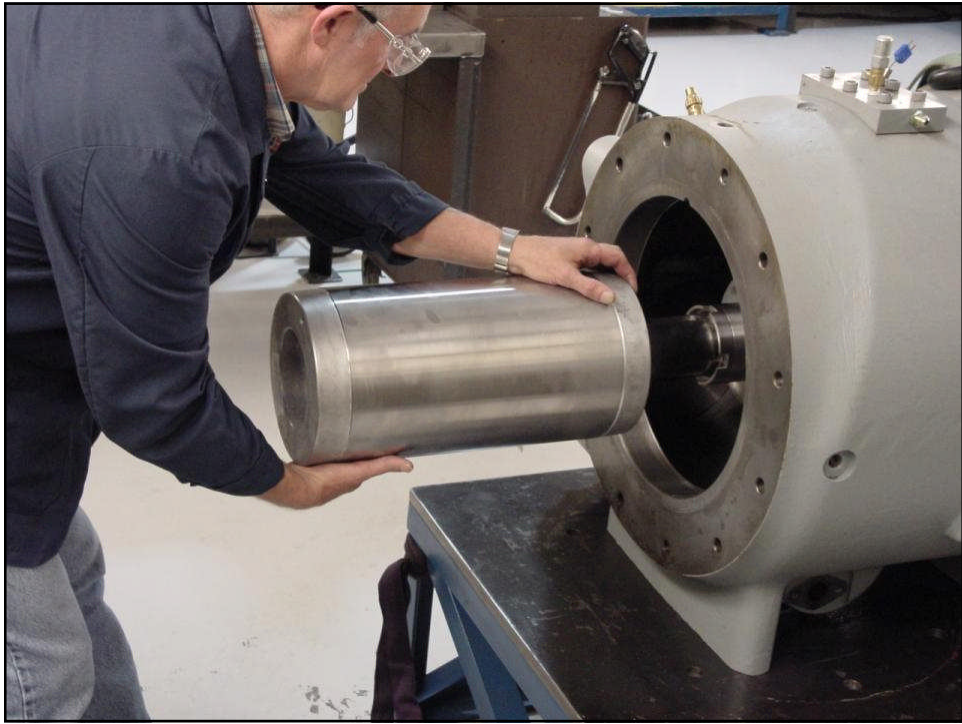



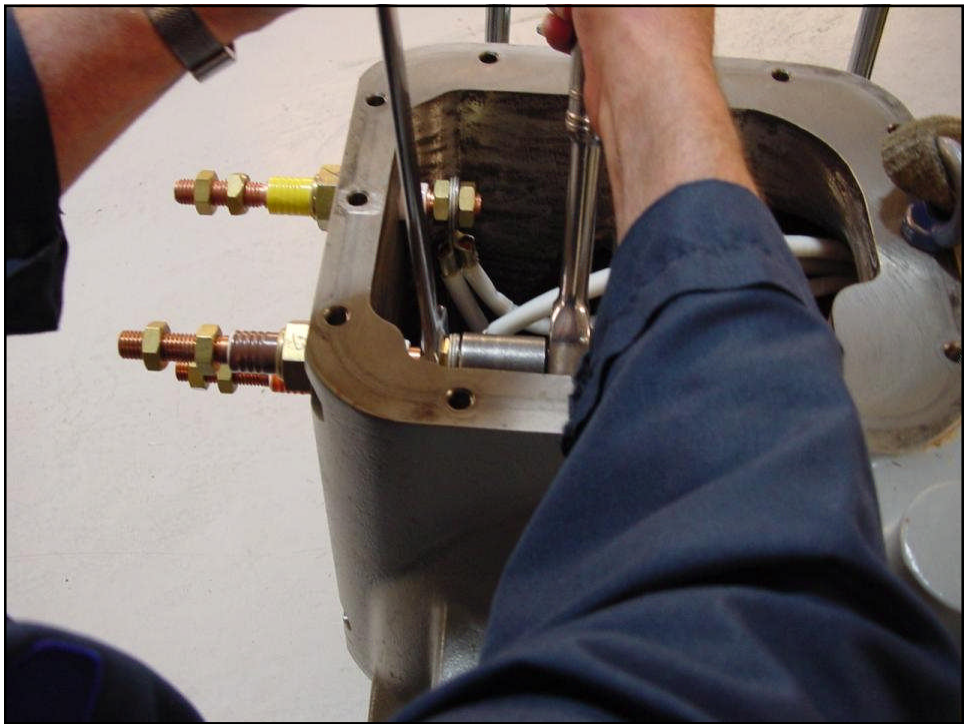
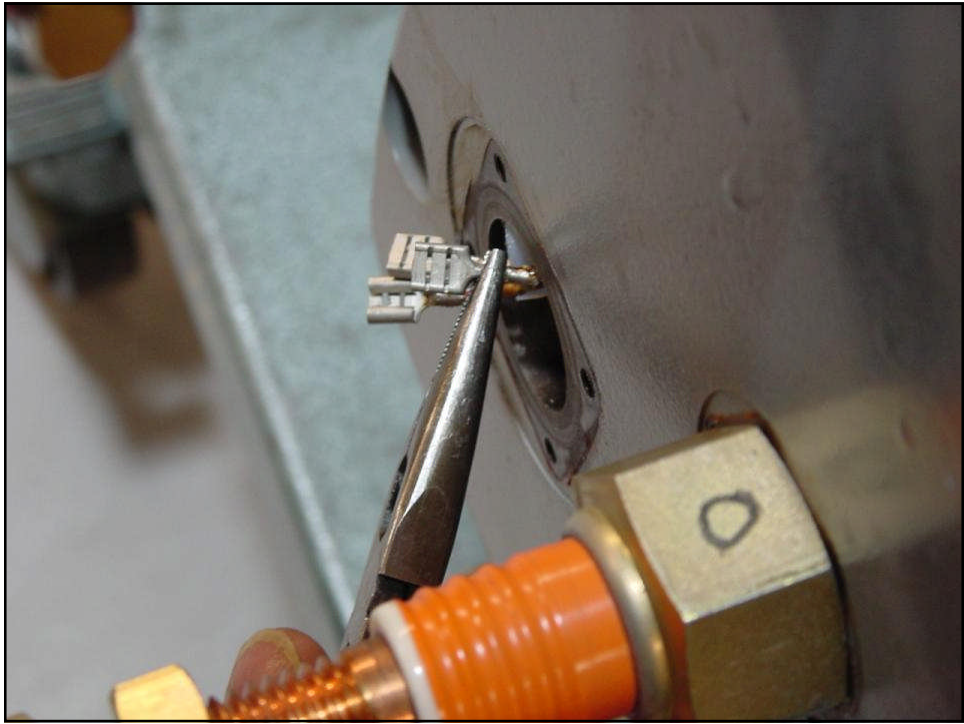

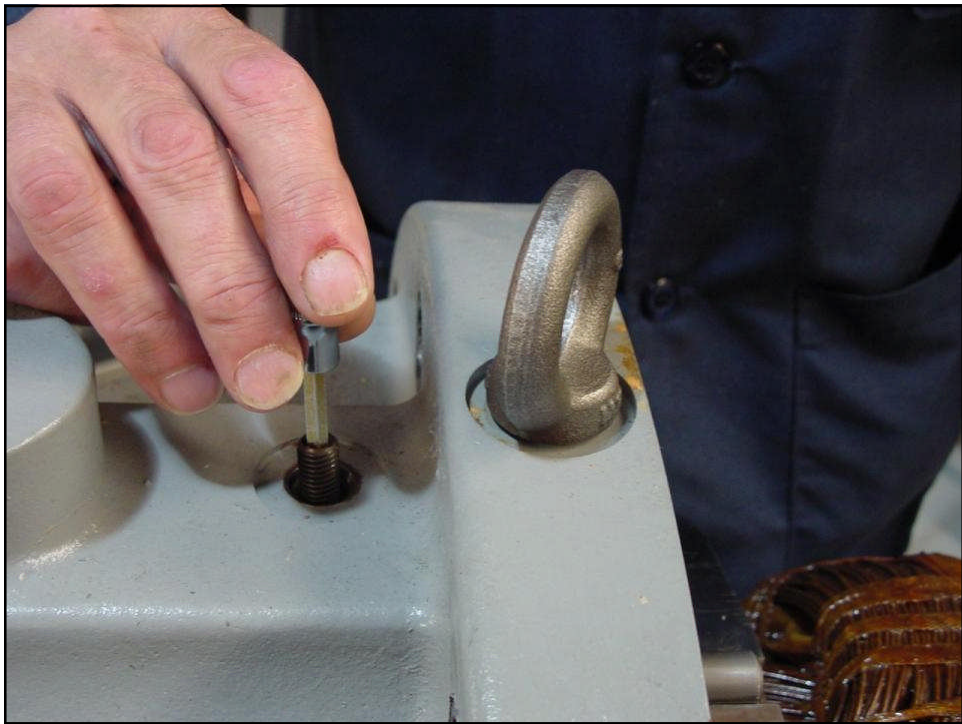

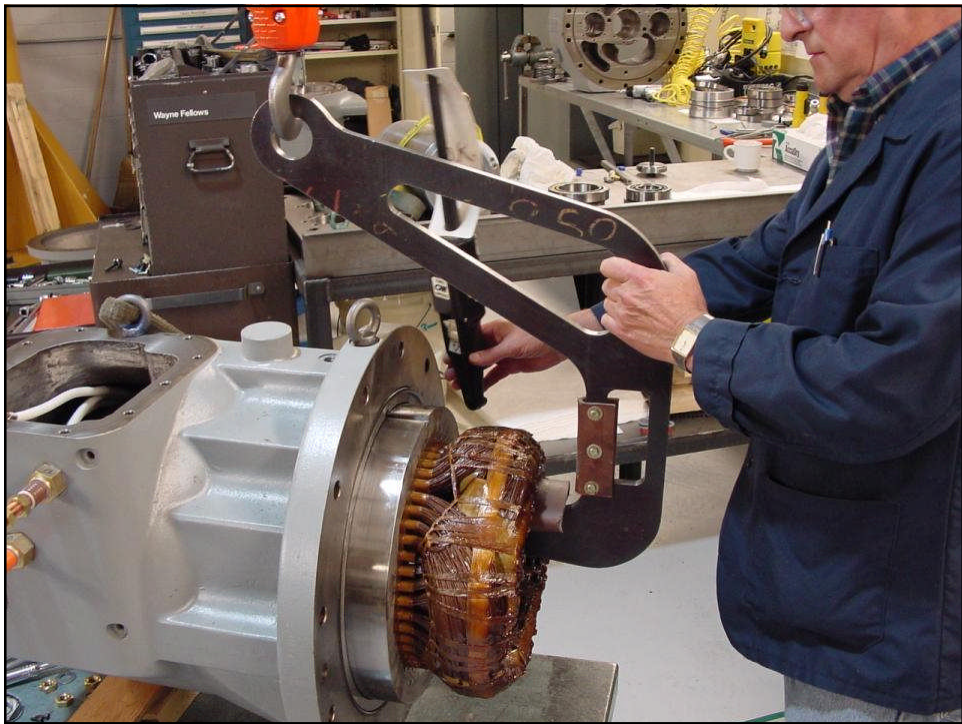
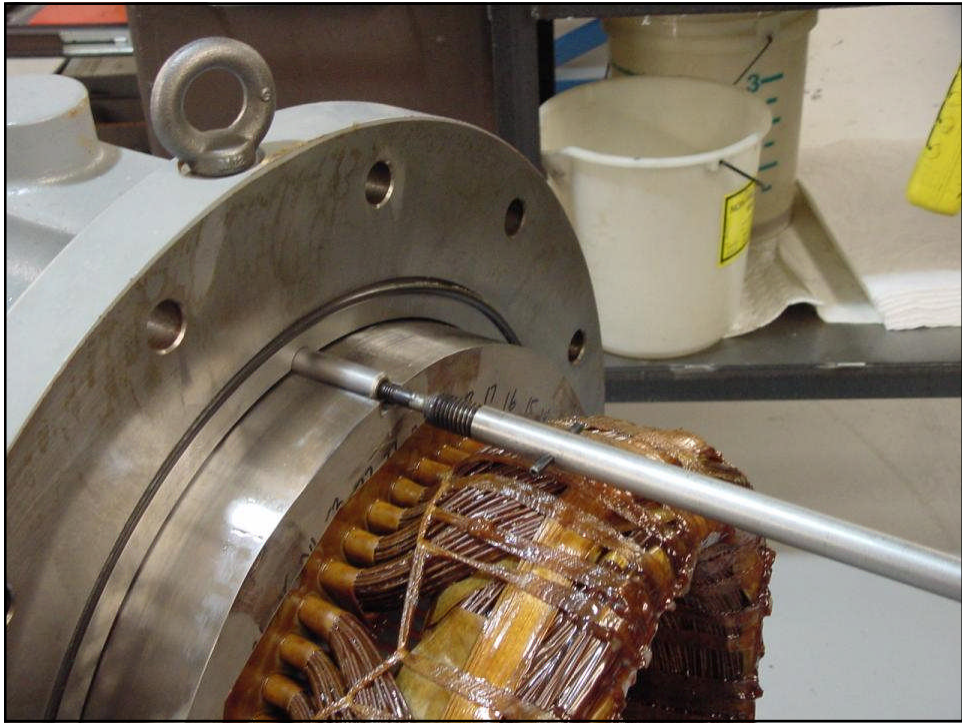



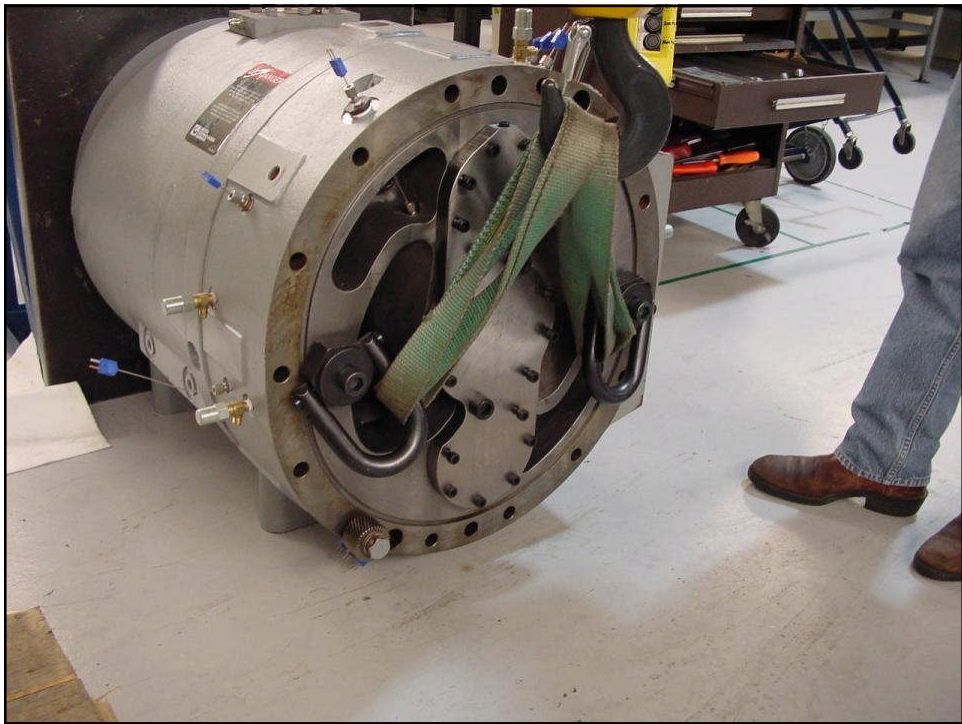
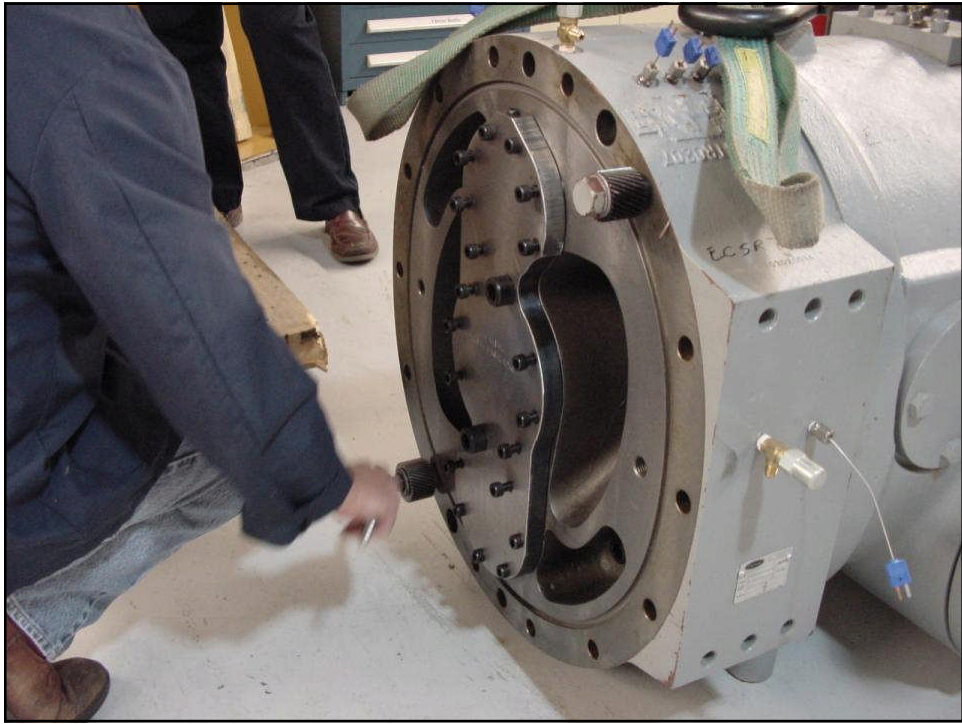



36.

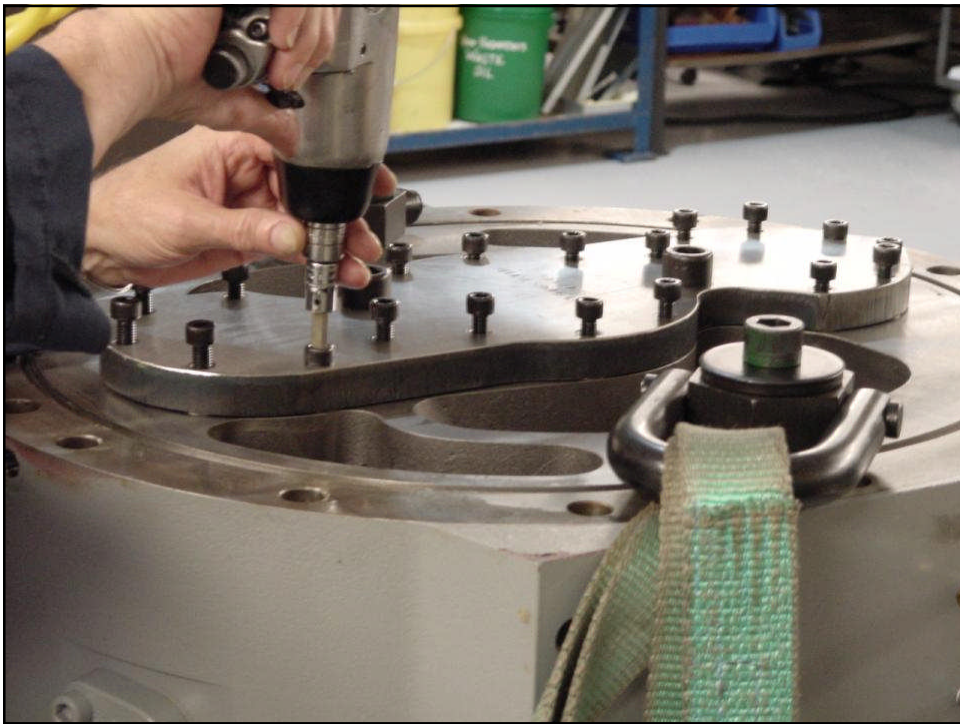
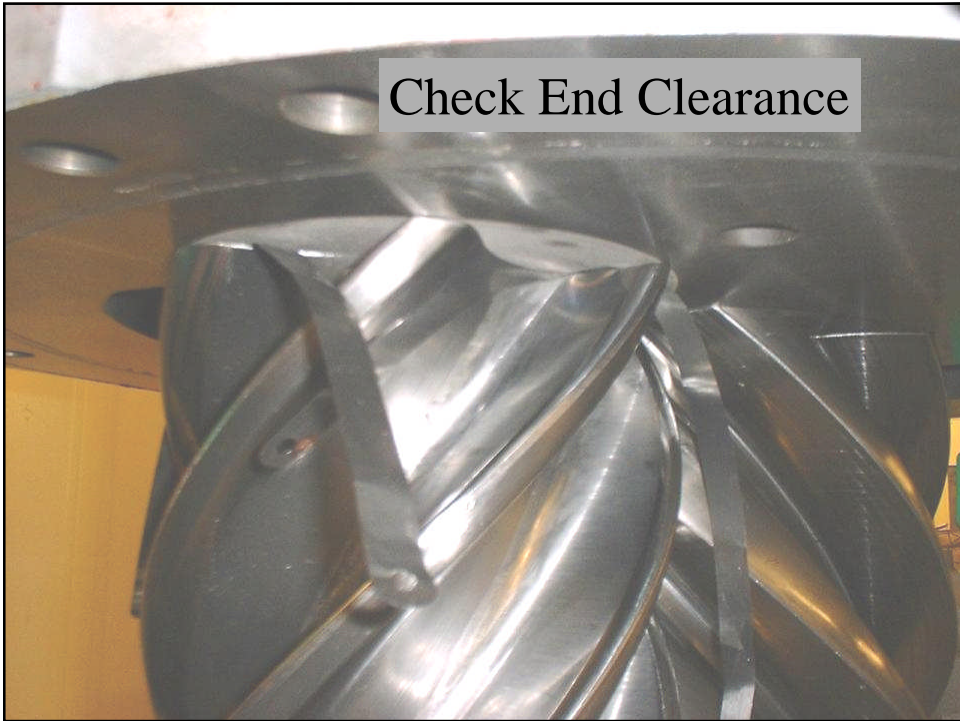



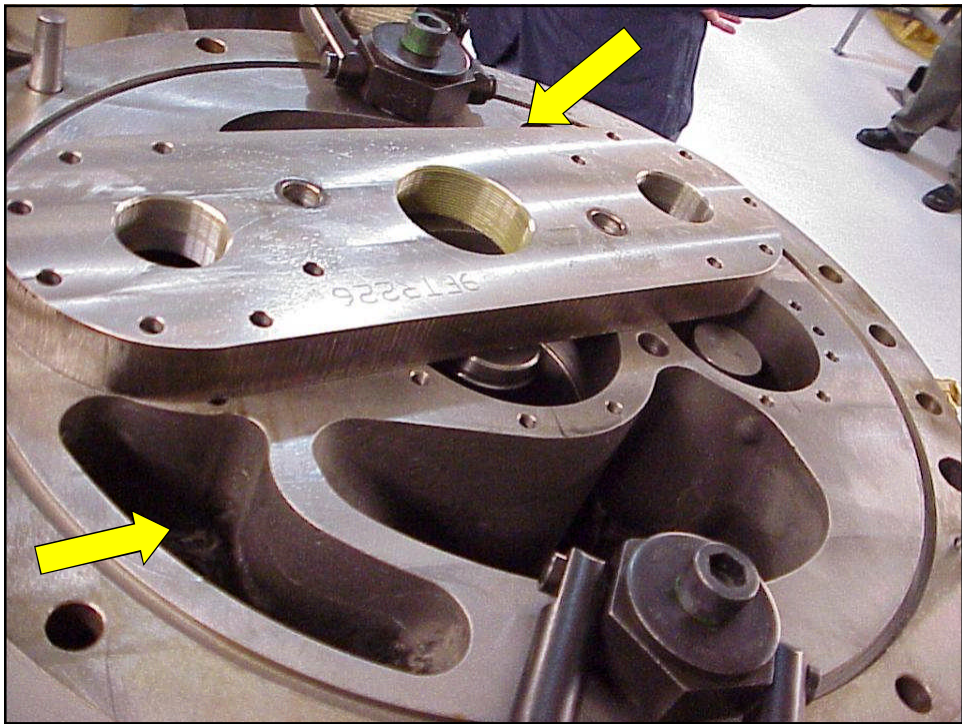
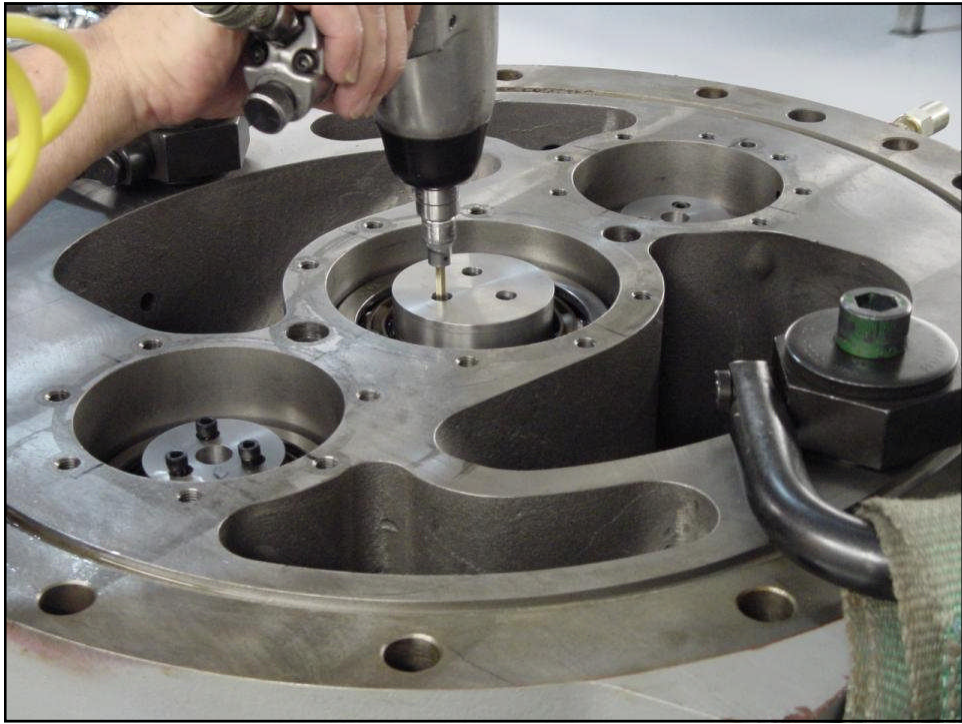



43.

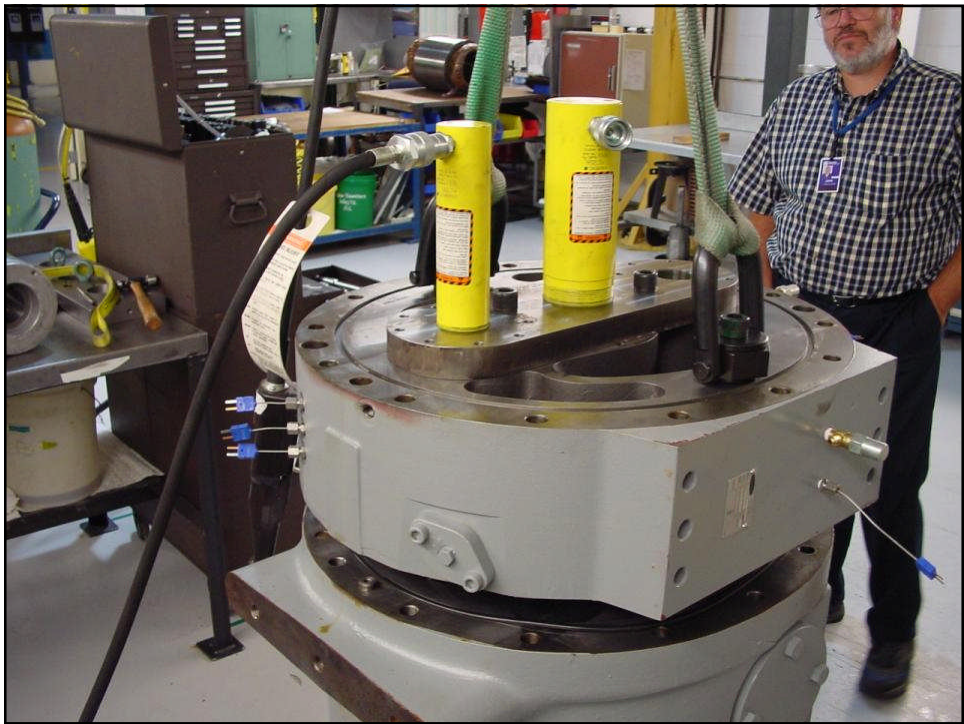

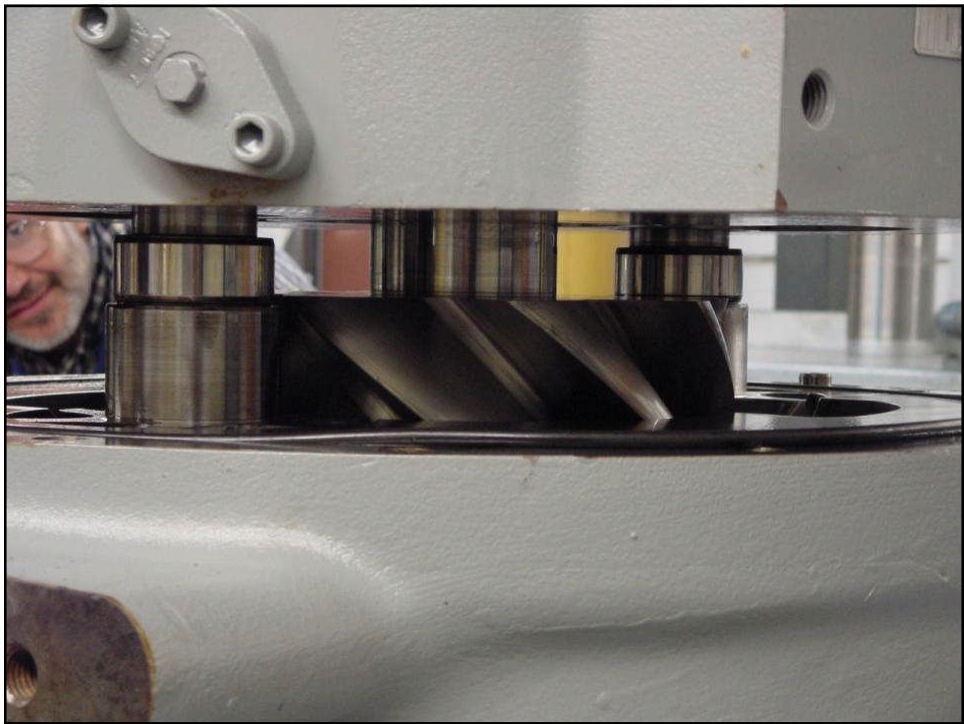
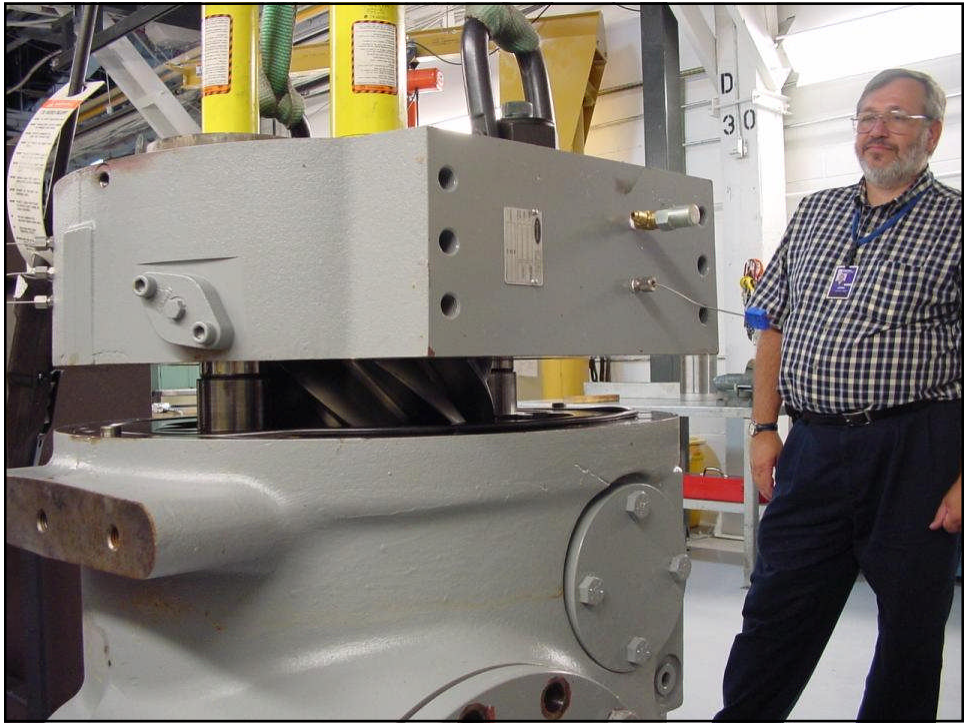

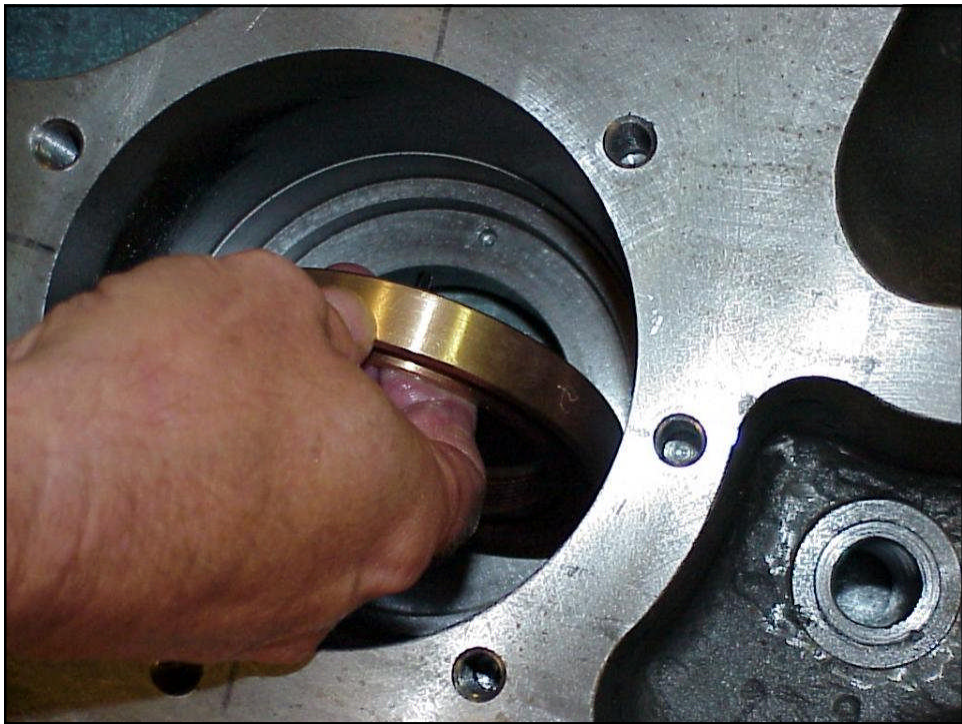
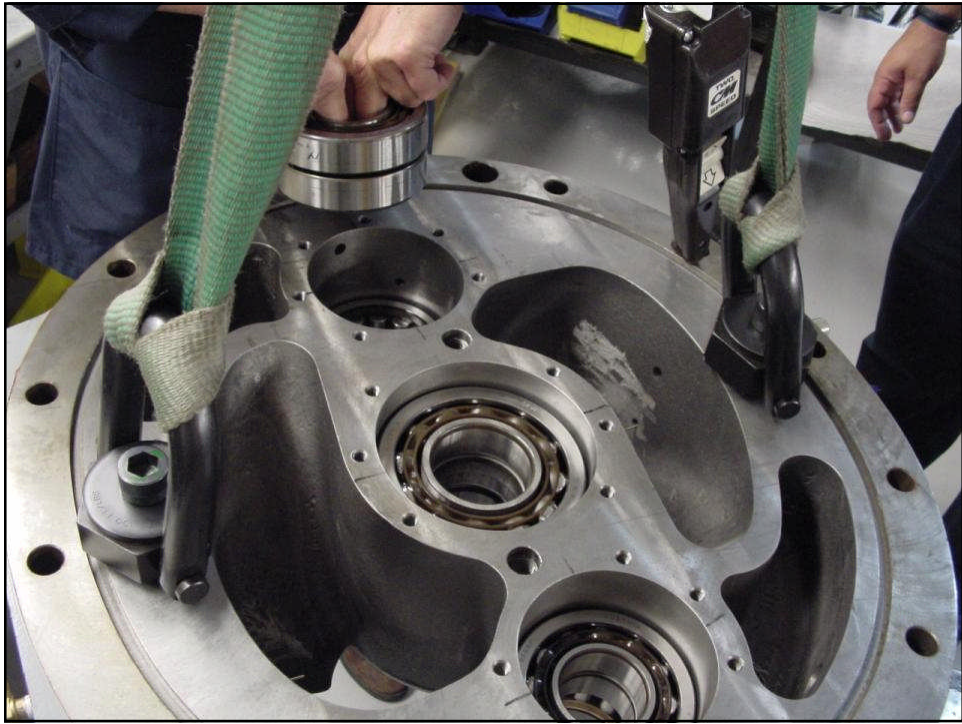



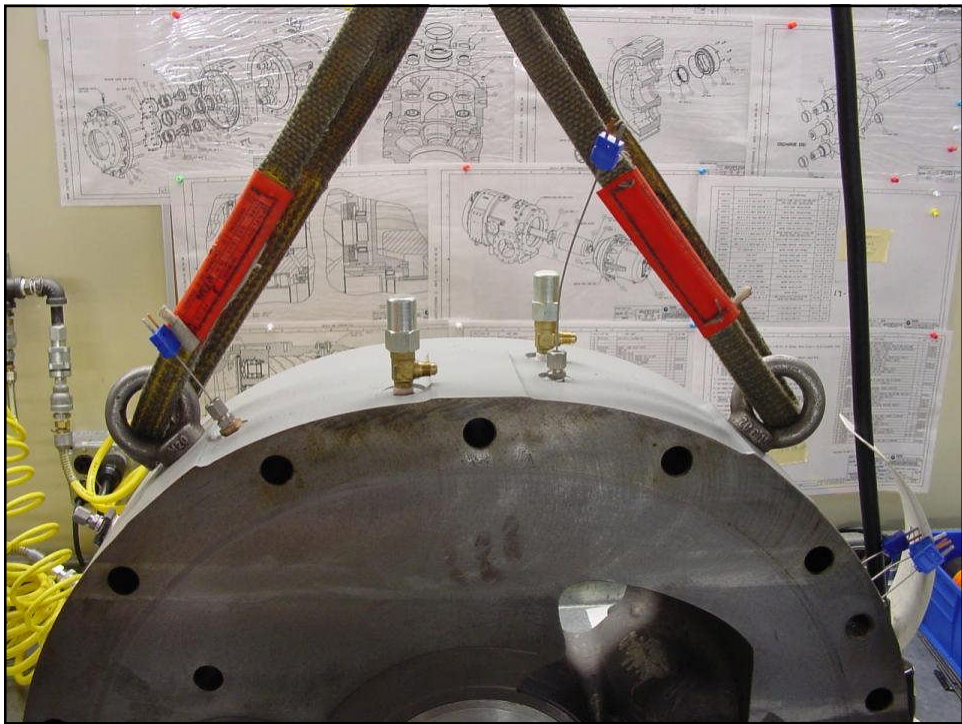
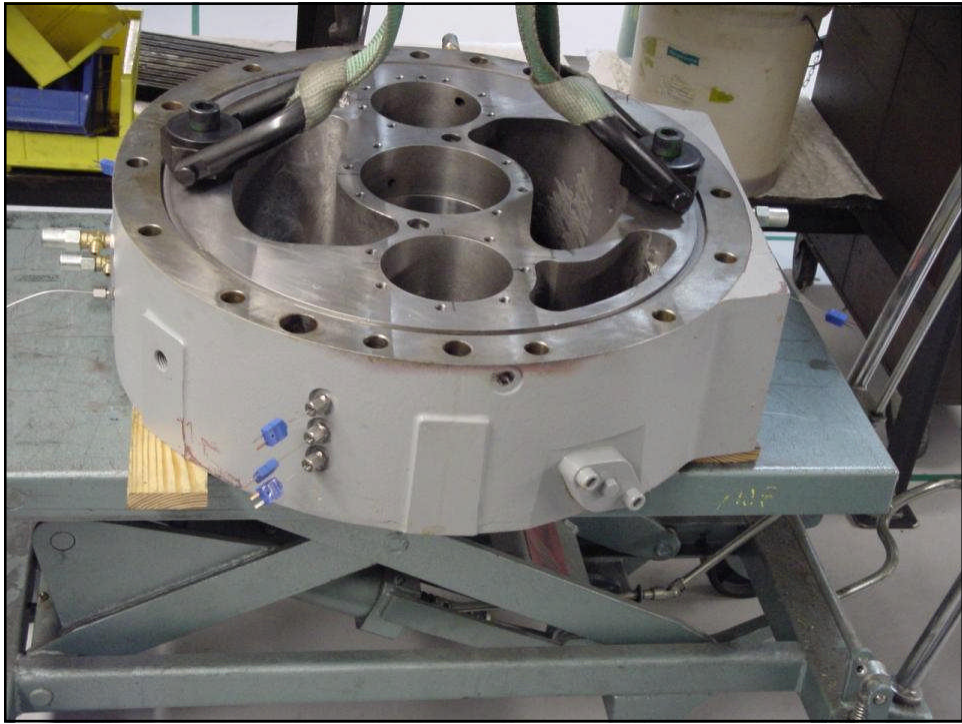

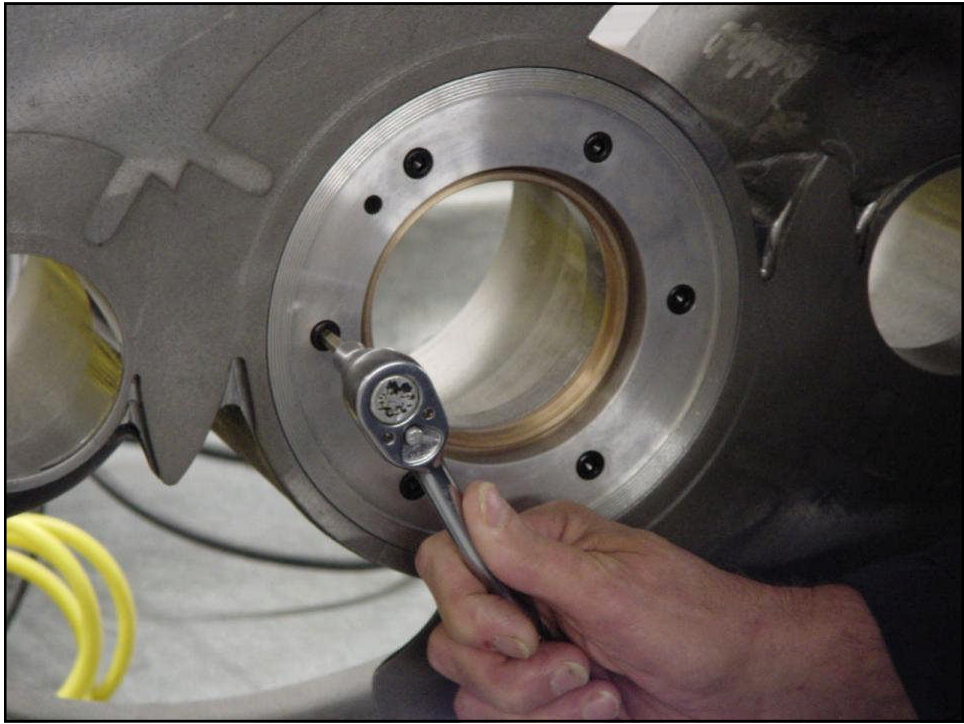

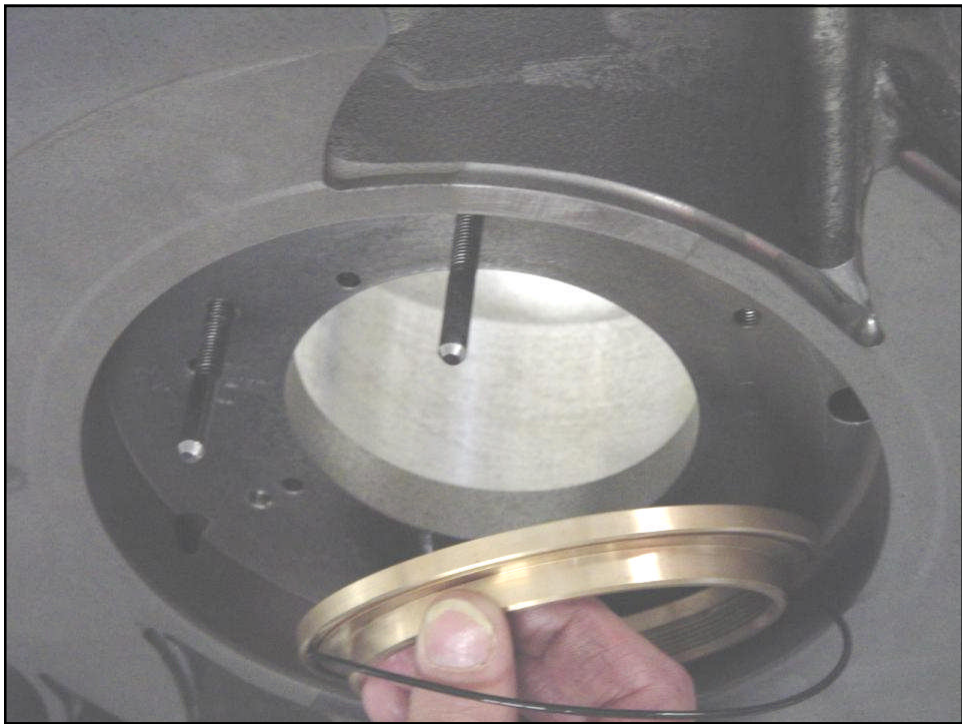
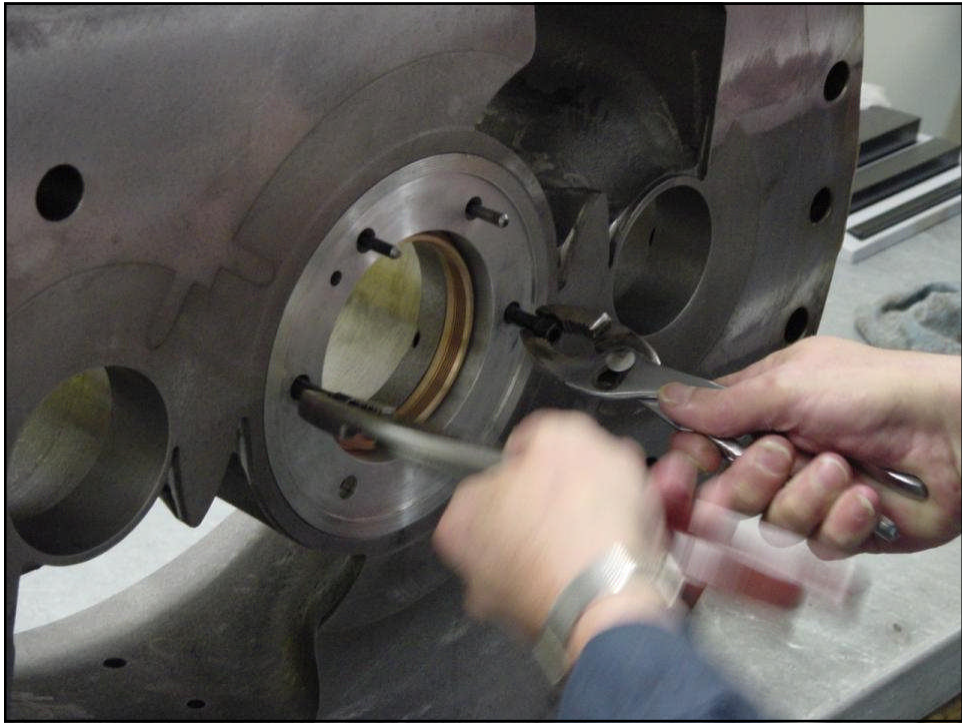

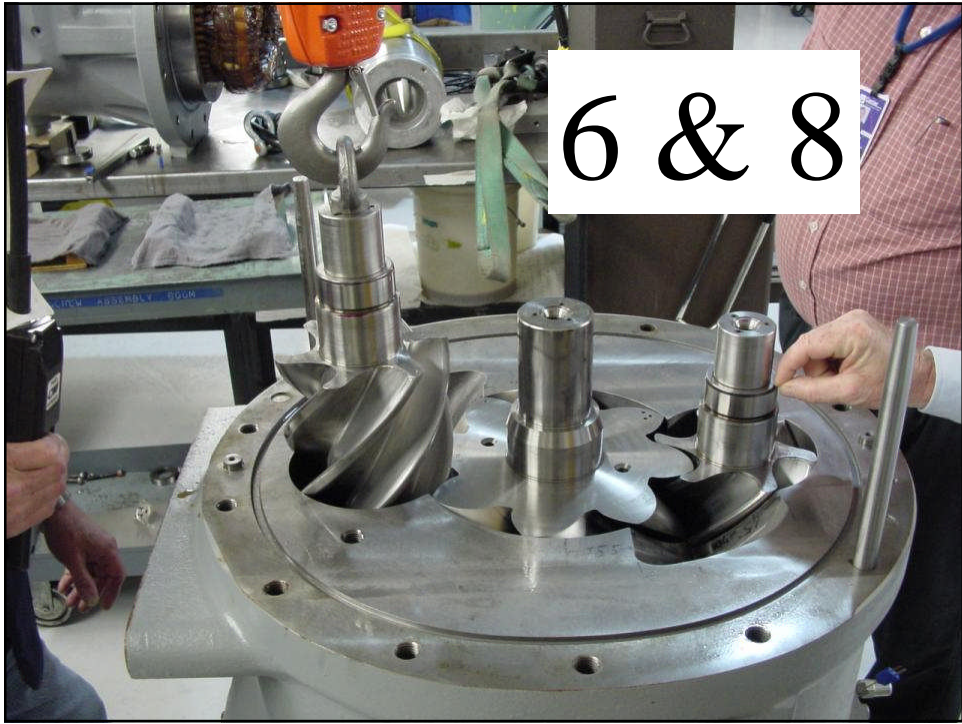

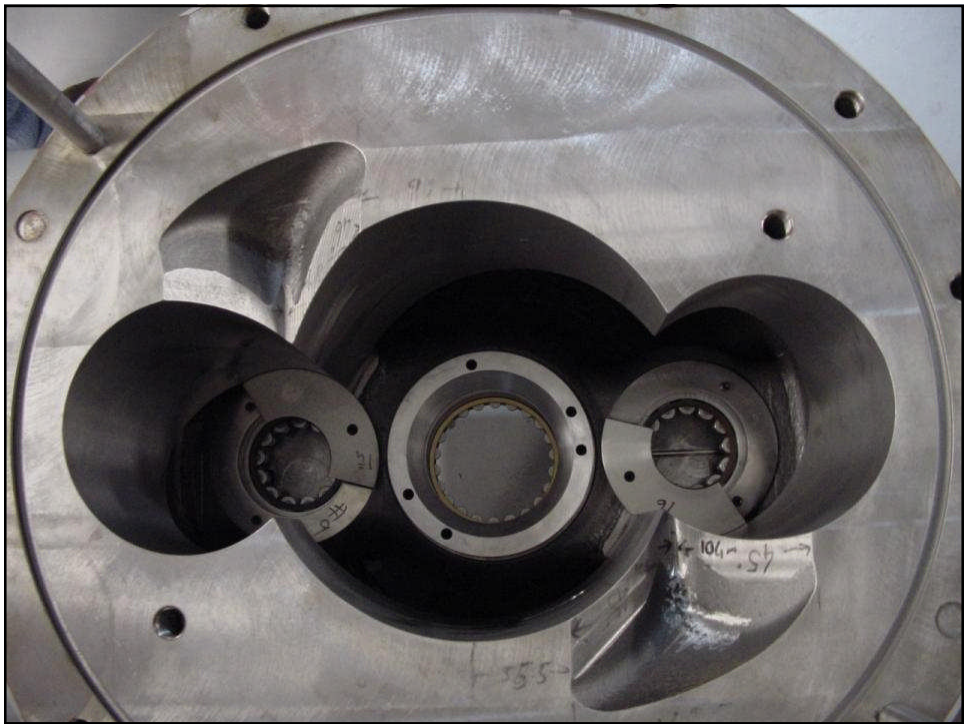
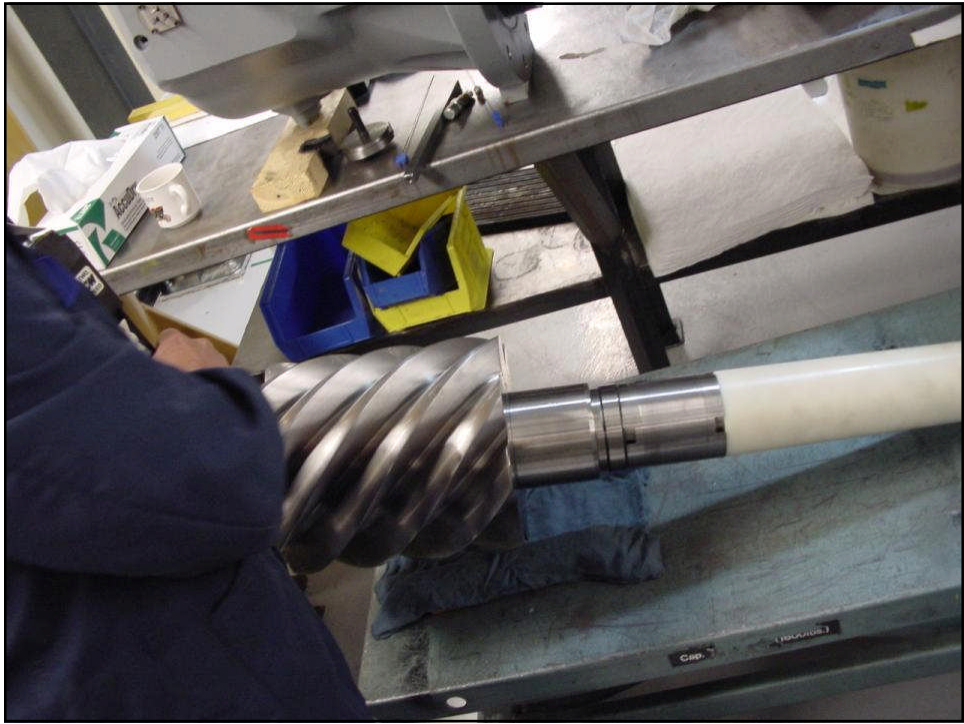





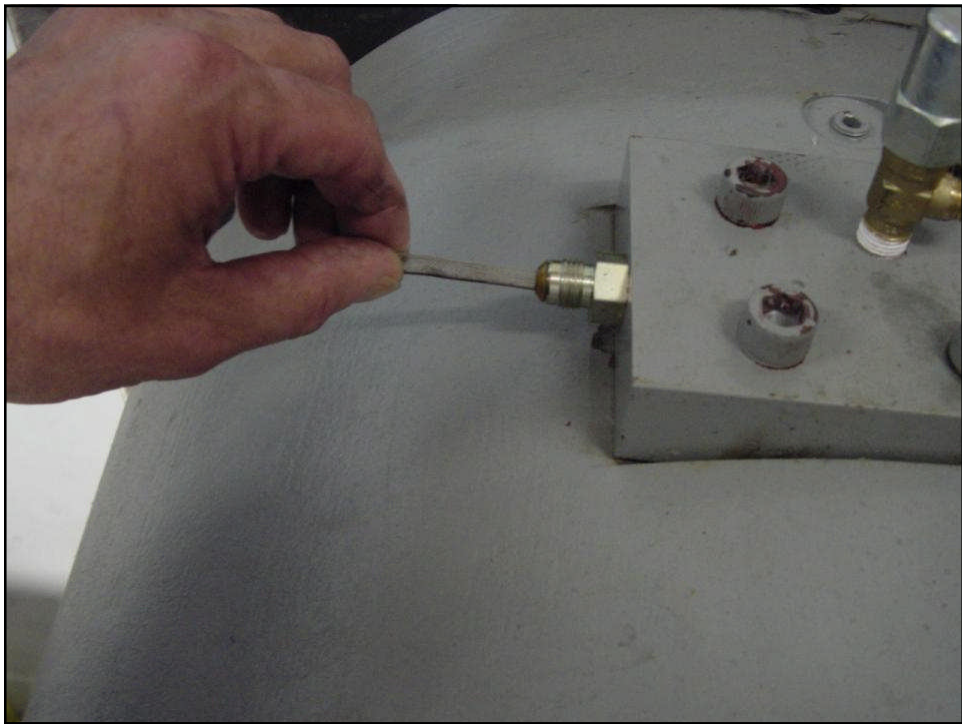
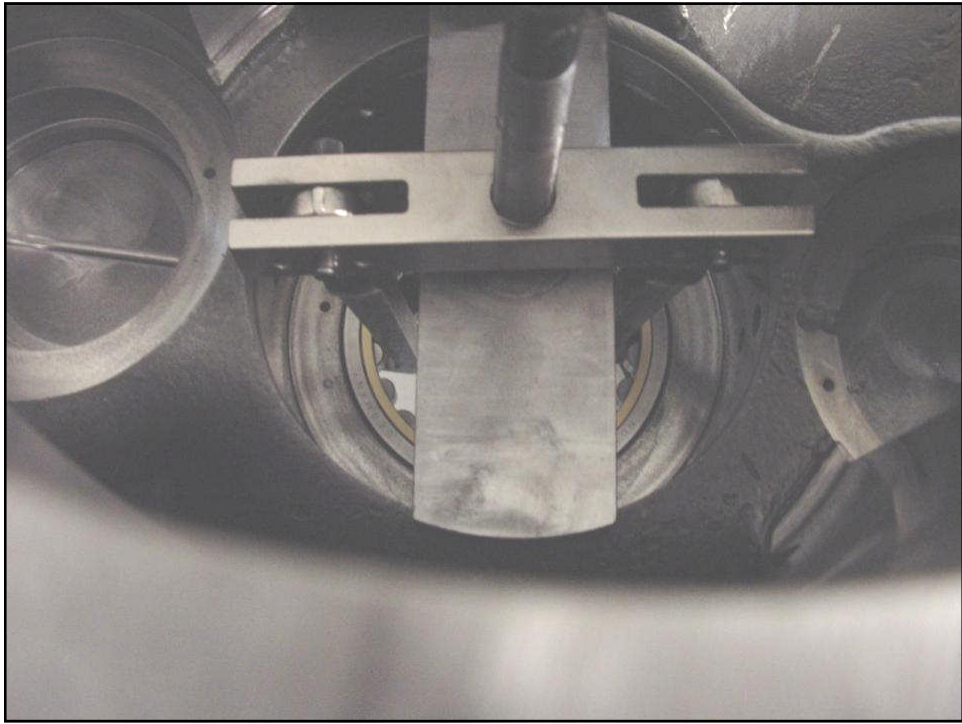

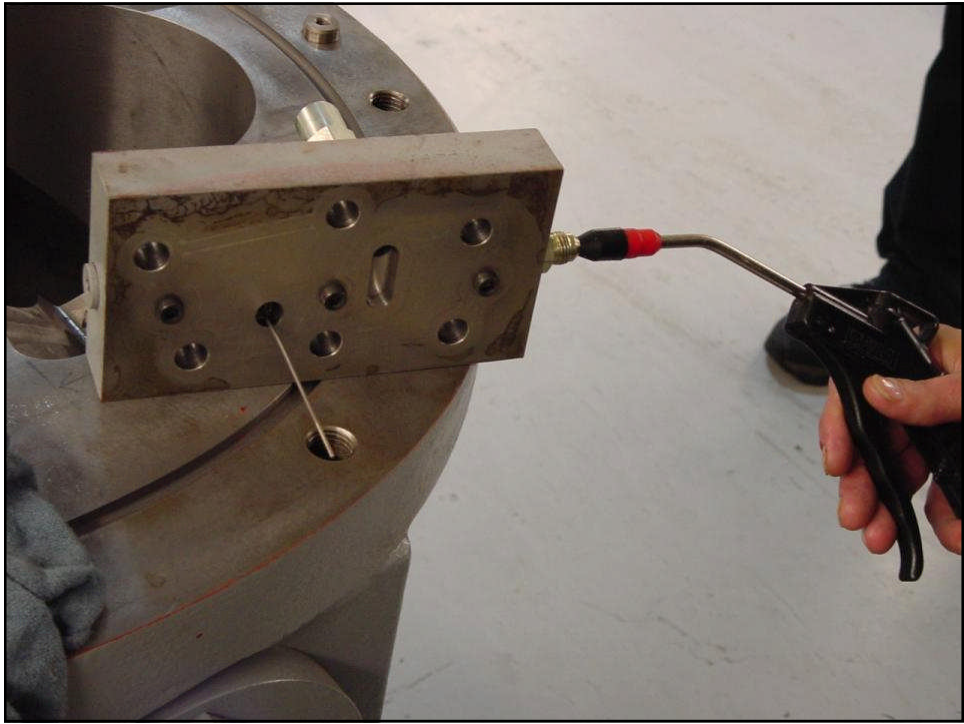

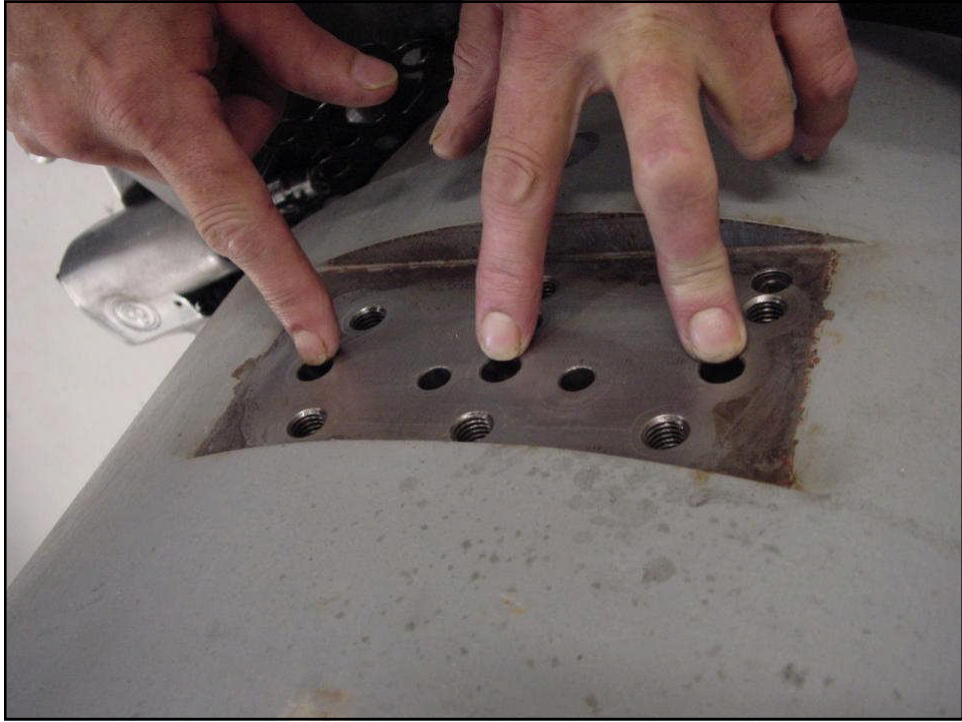



Picture of normal bearing wear



72.

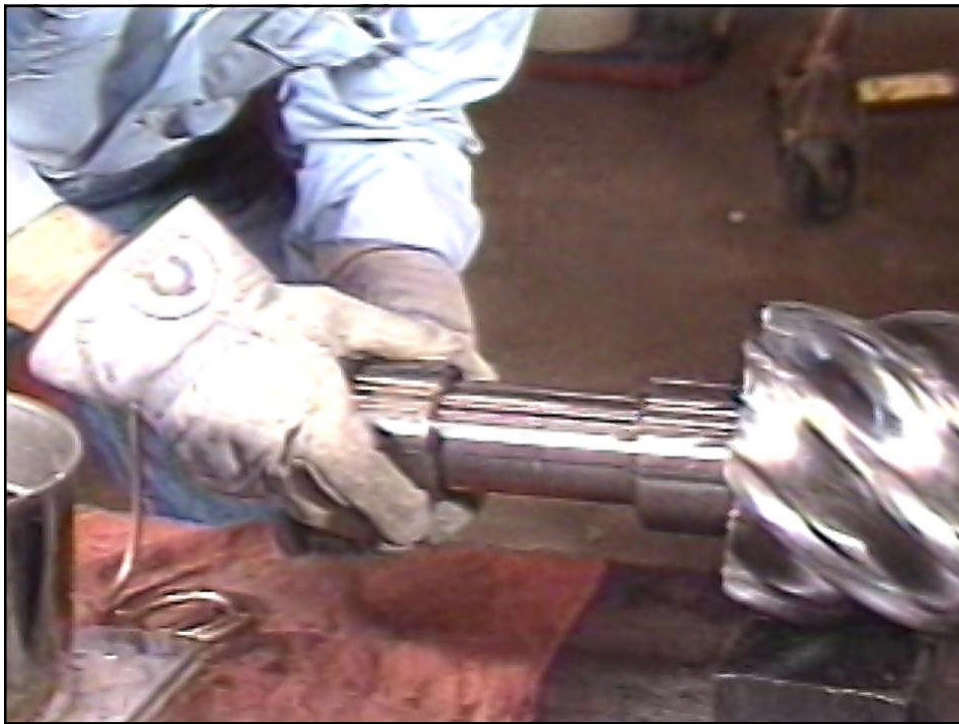
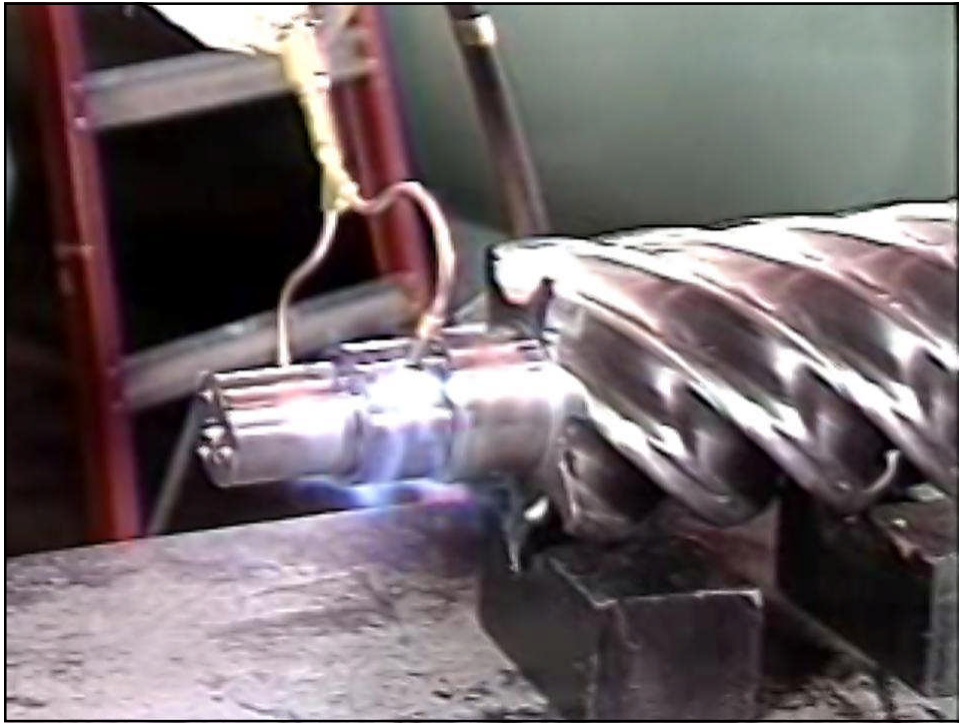

Show a picture of inserting the outer races.

Copyright Carrier Corp. 2003

75.

Identify the rotors

Copyright Carrier Corp. 2003

76.

Picture of pulling the male bearing components out of box.

Copyright Carrier Corp. 2003

77.



Insert outer race

Copyright Carrier Corp. 2003

79.

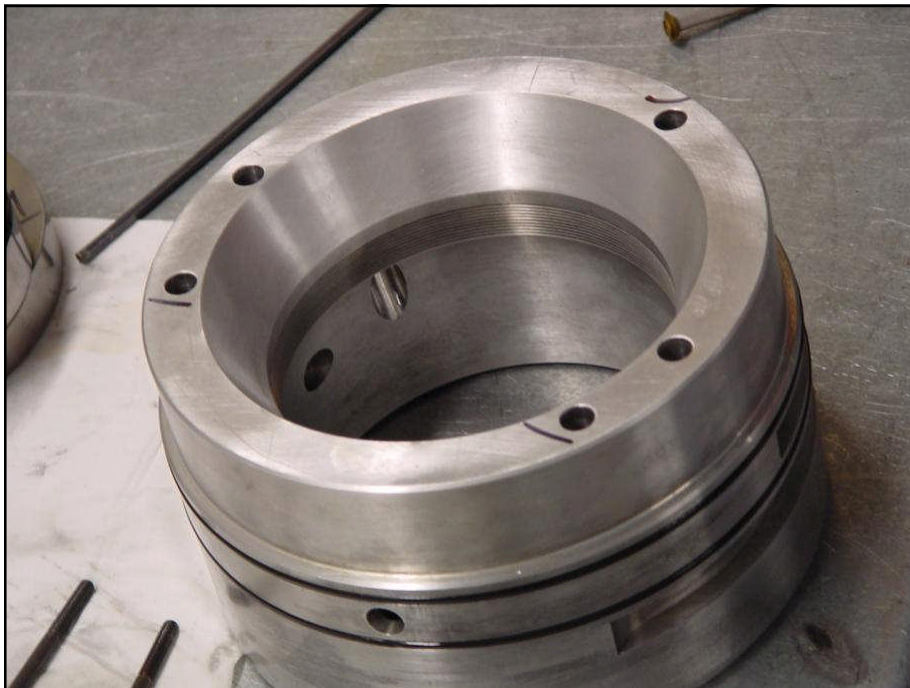

Copyright Carrier Corp. 2003

80.

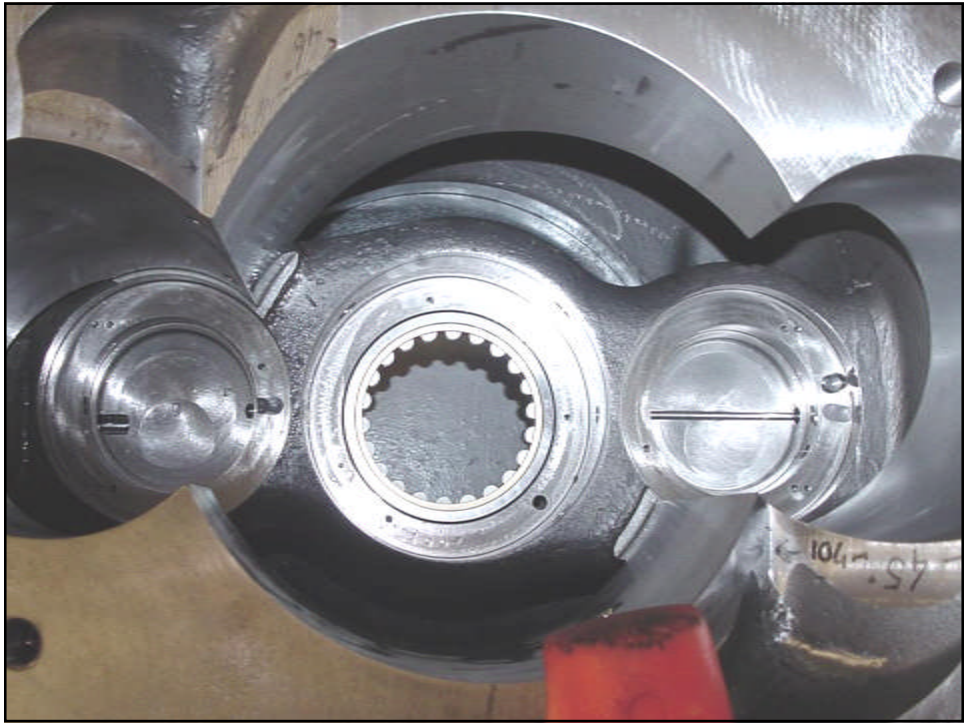

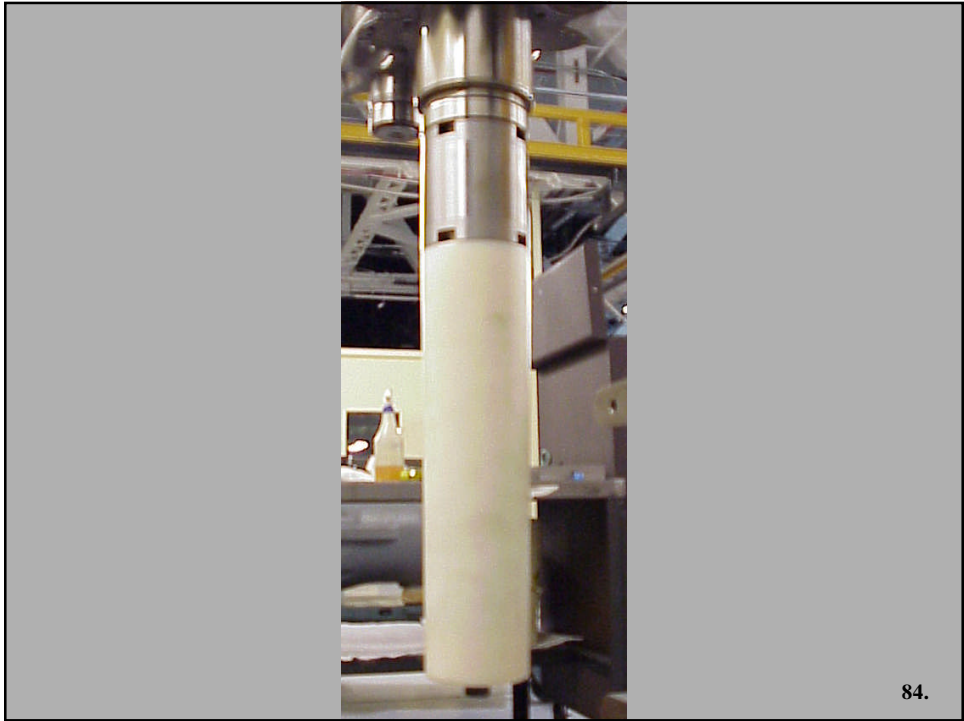
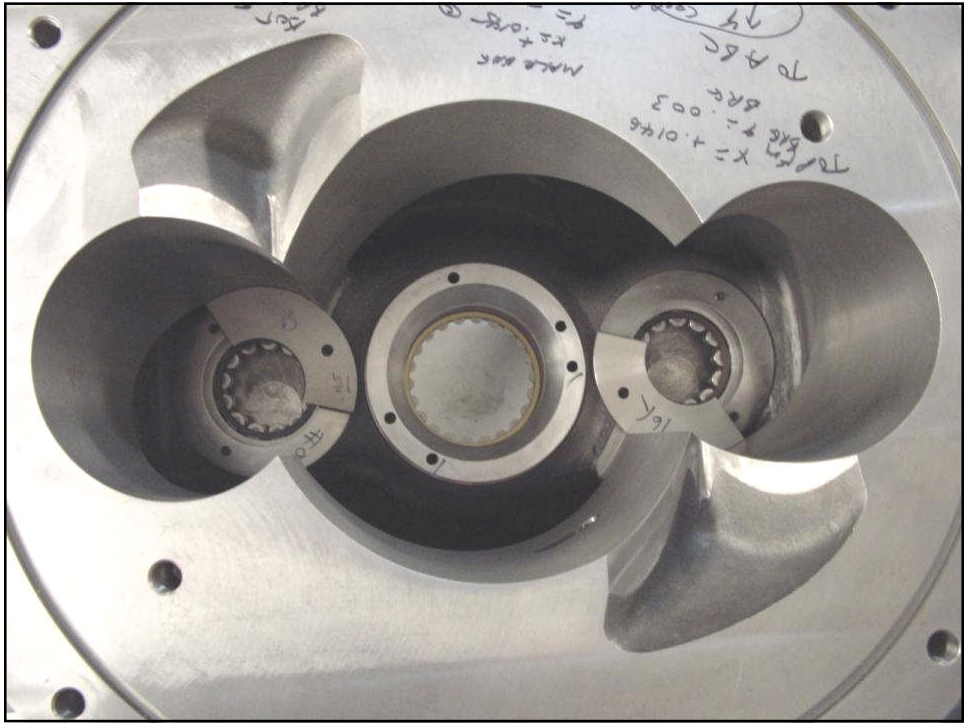

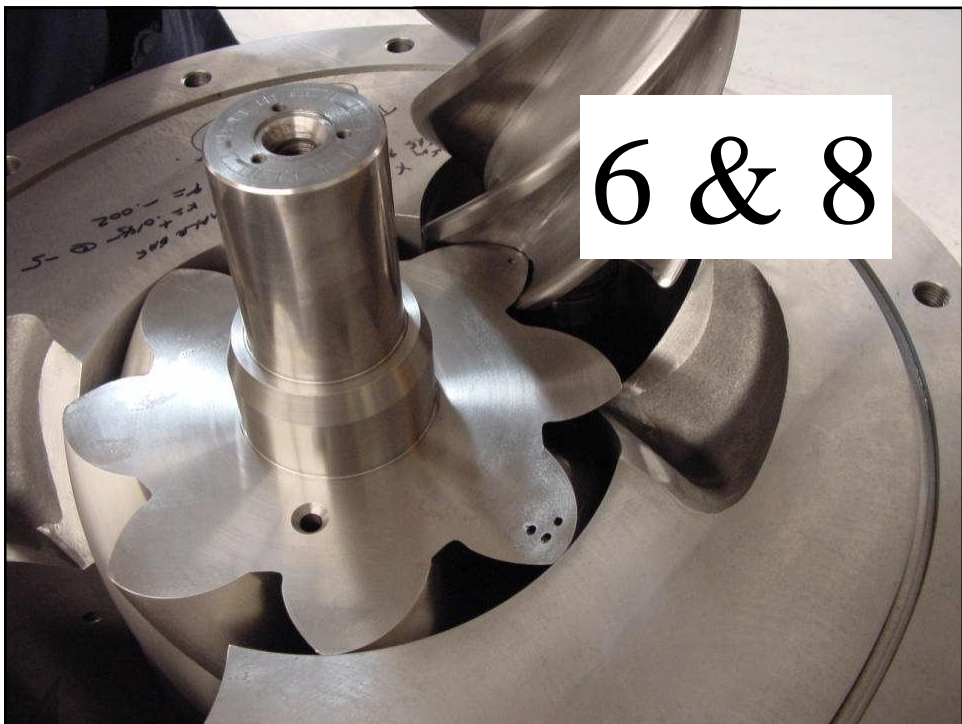
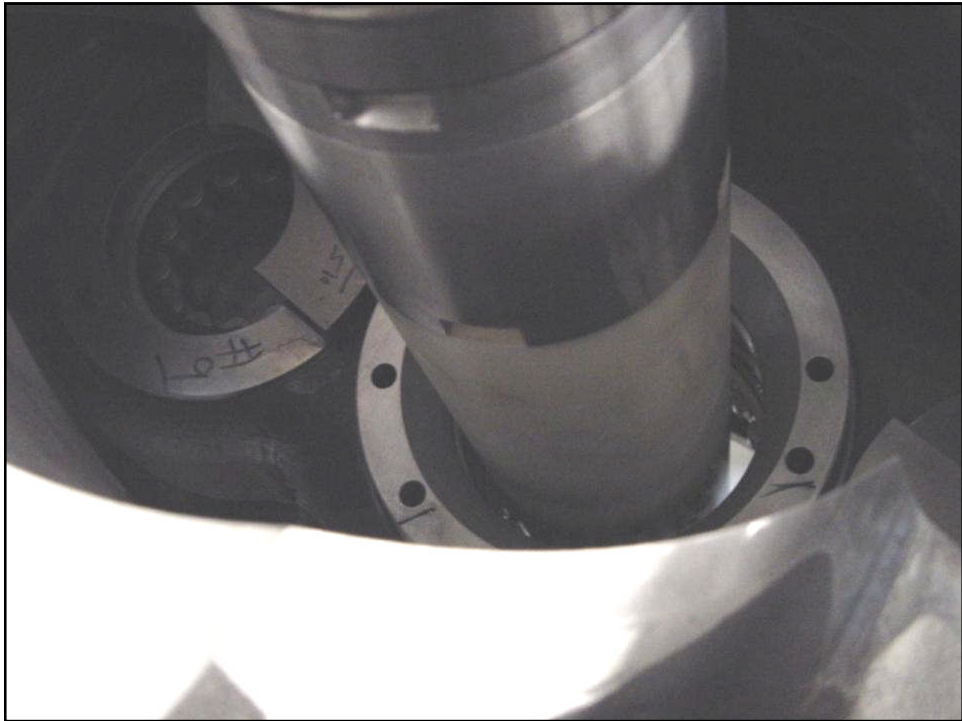

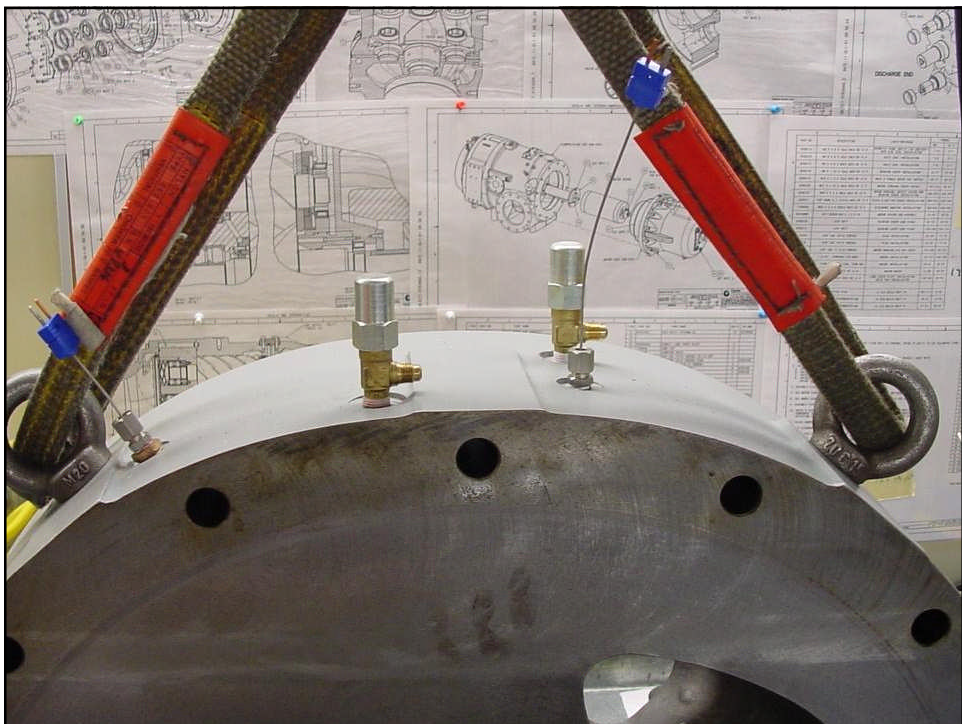
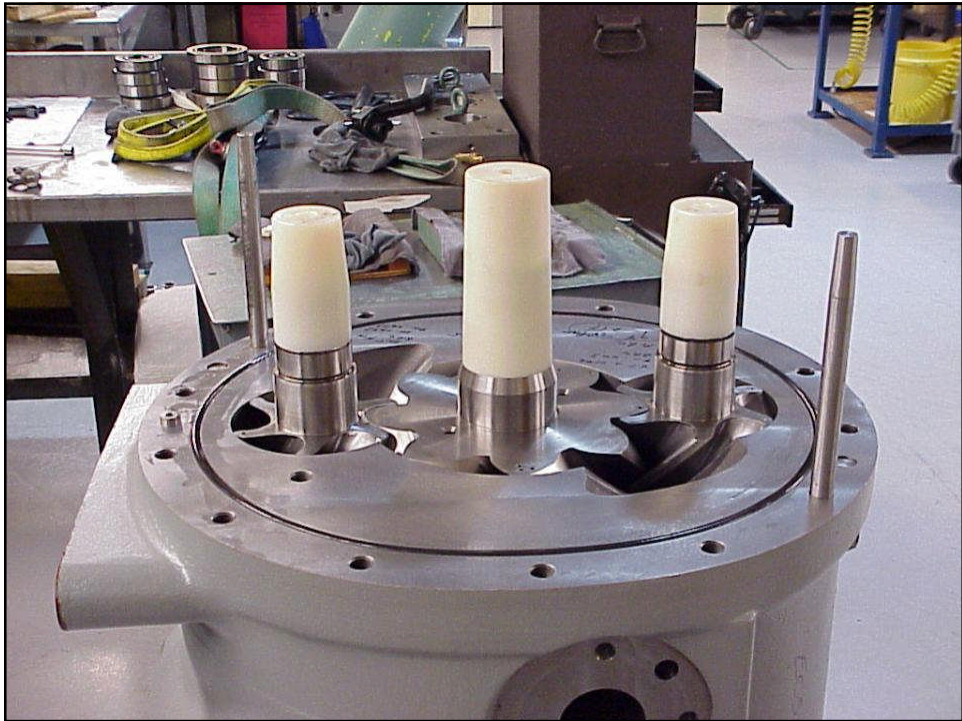

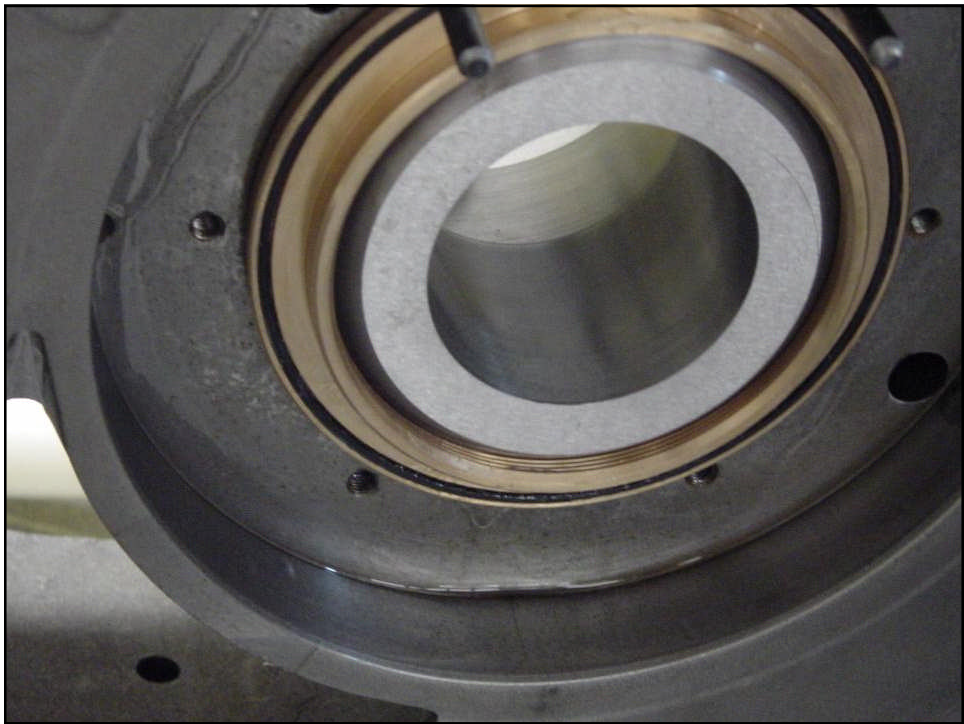
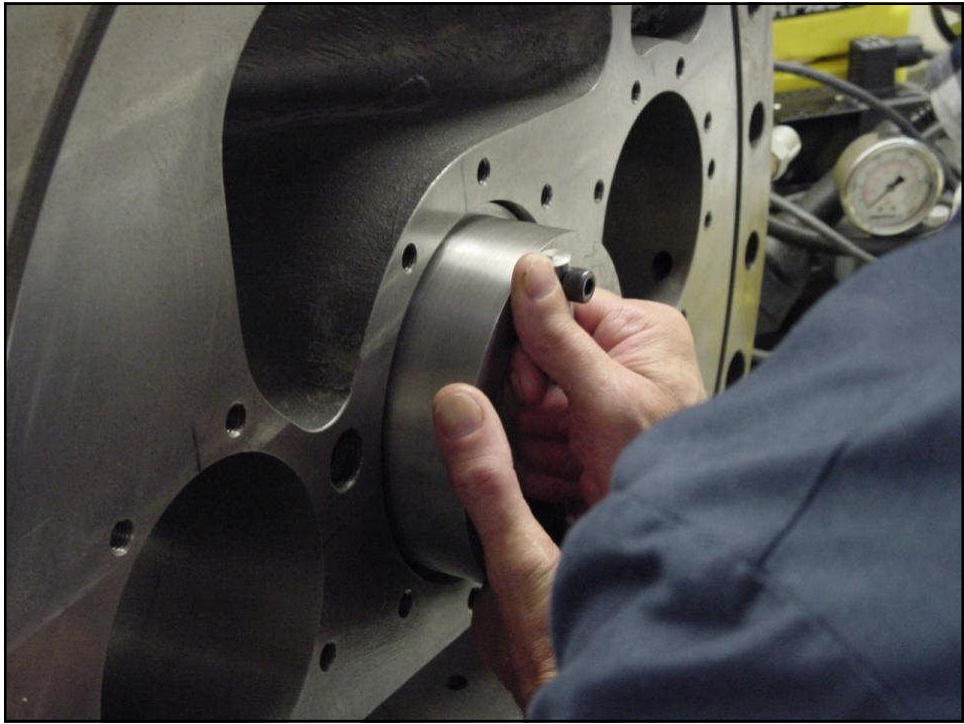

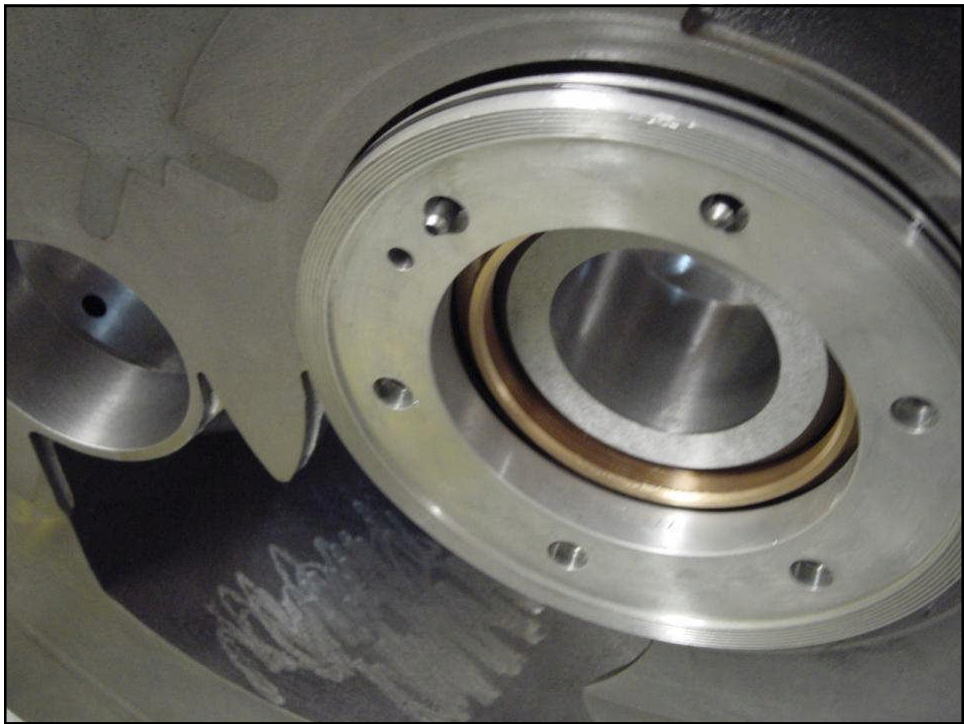

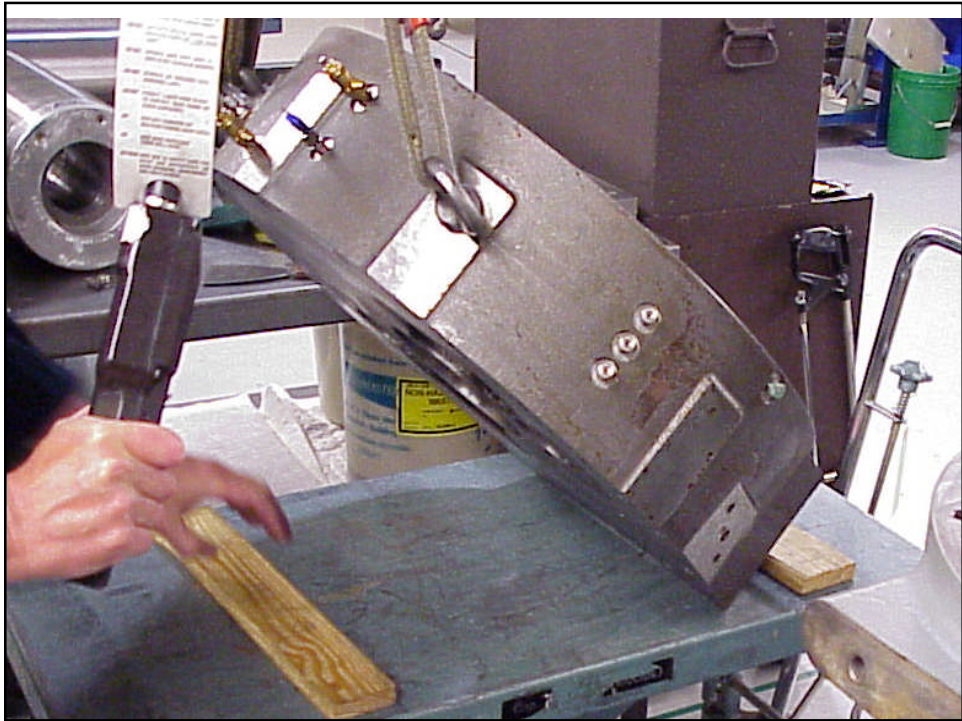
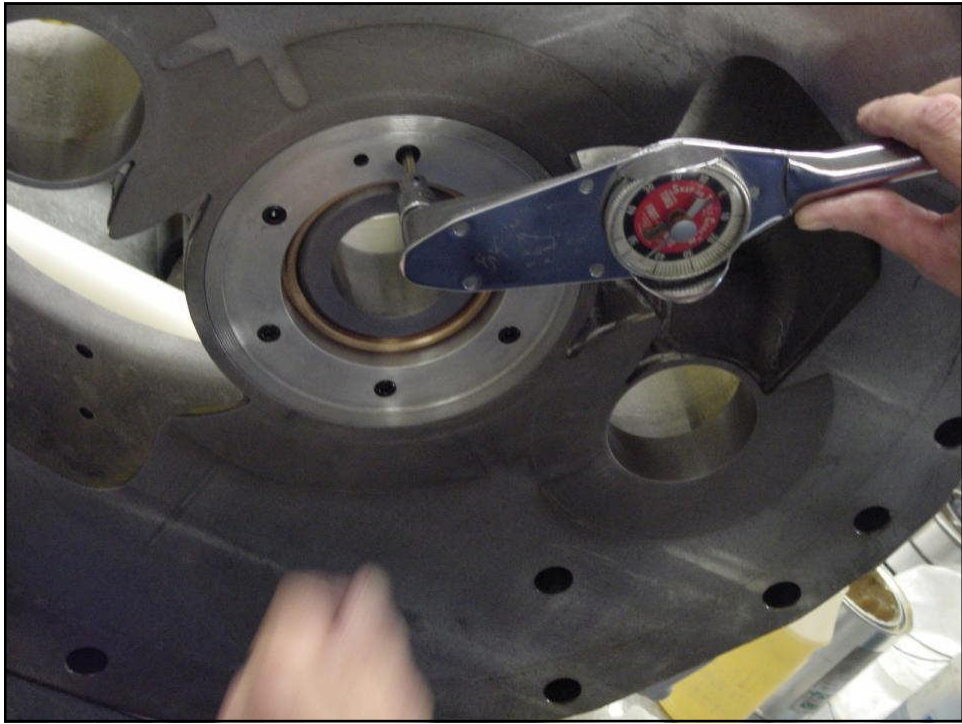

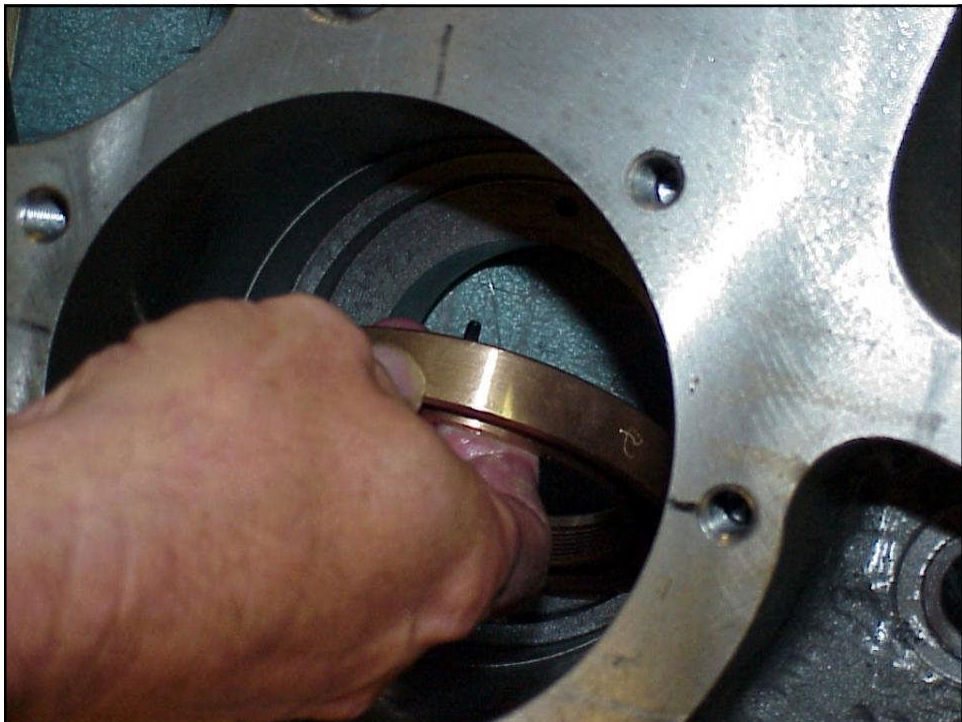
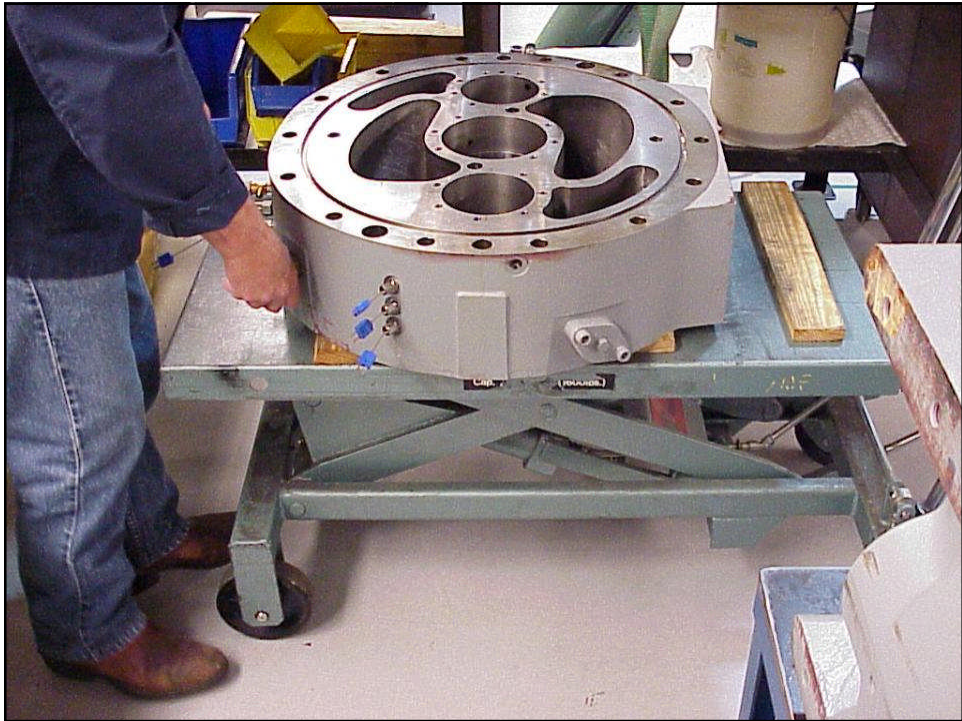

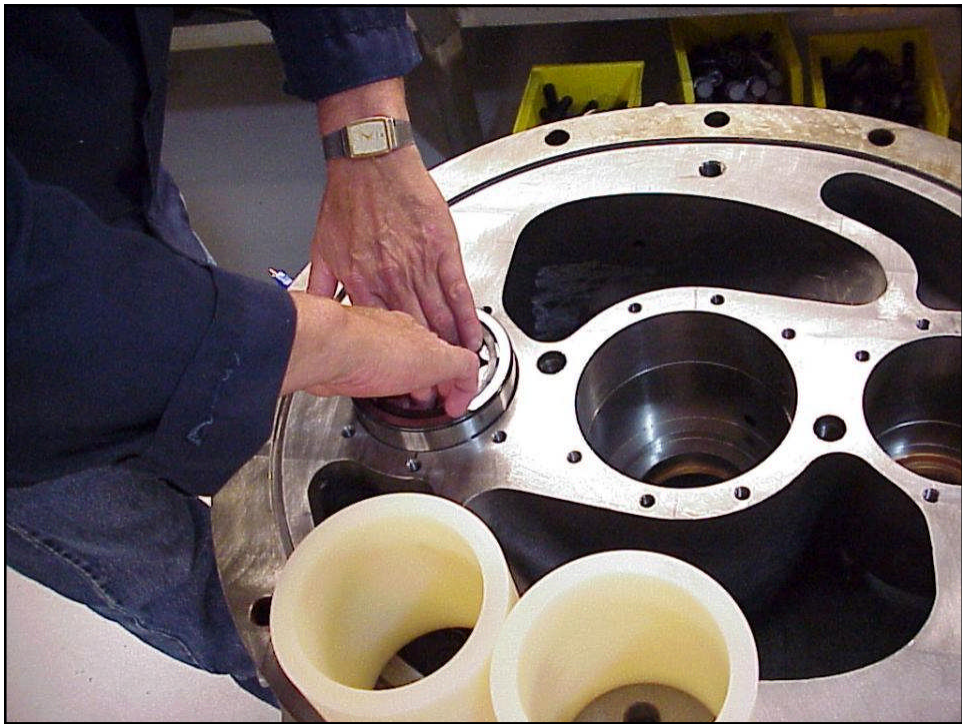
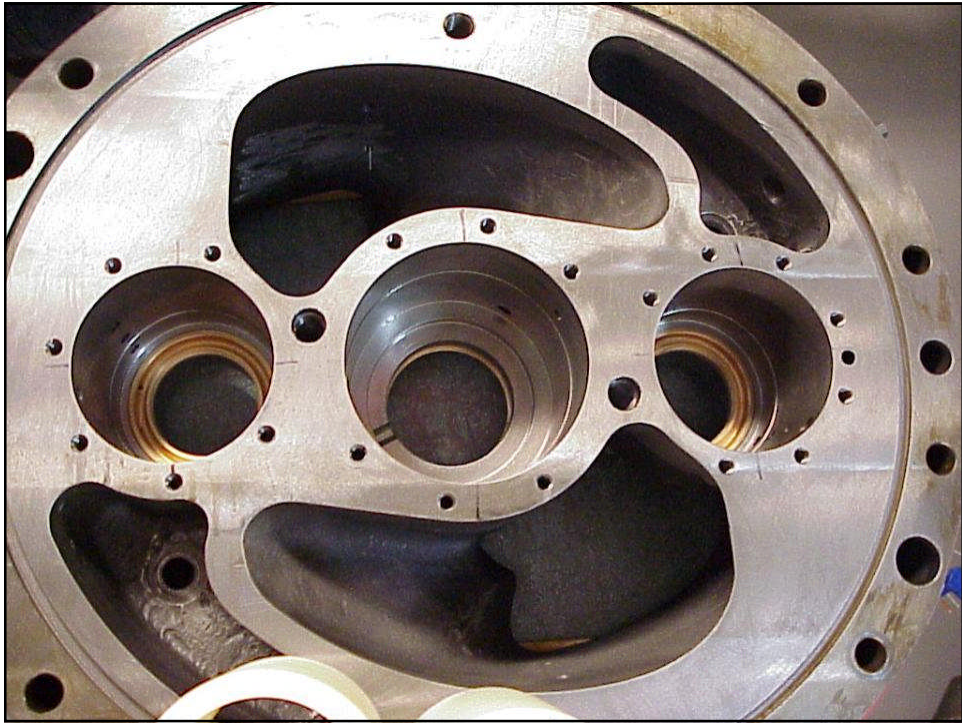

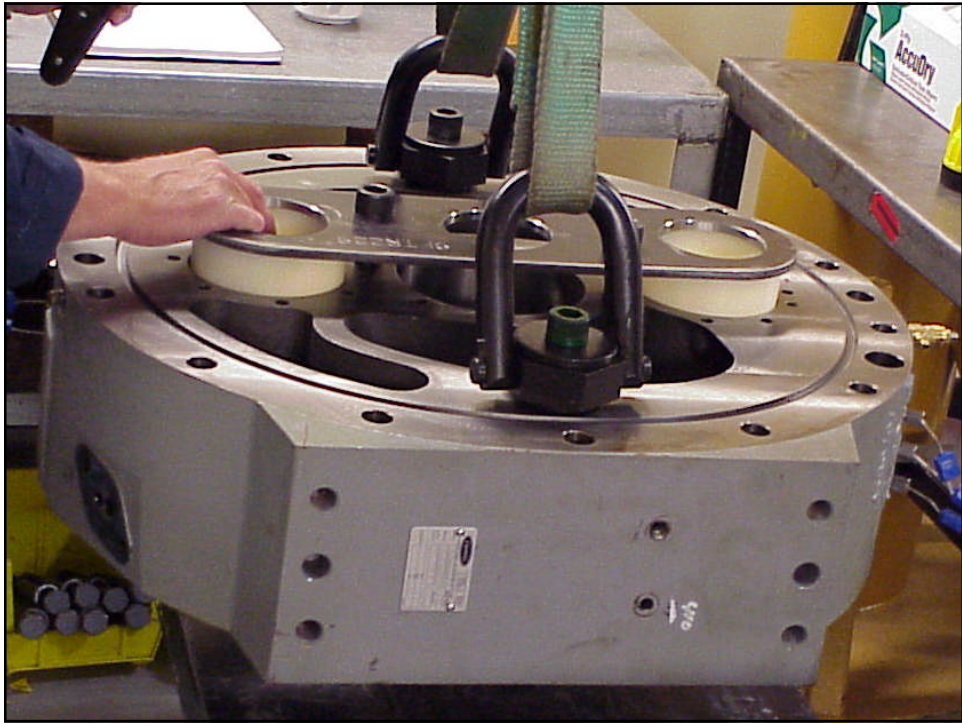

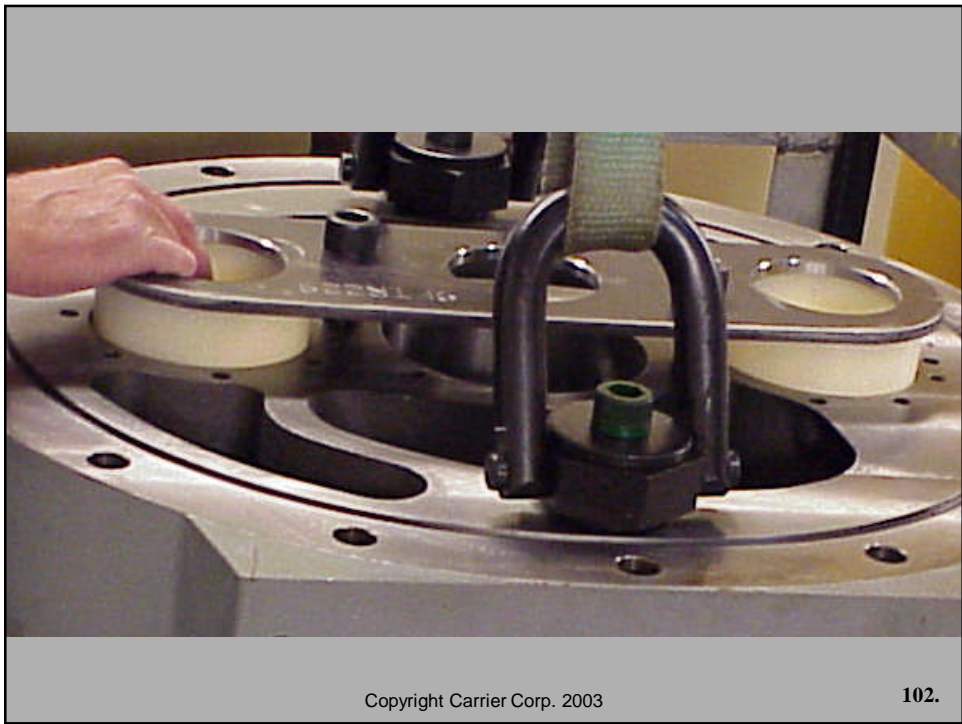
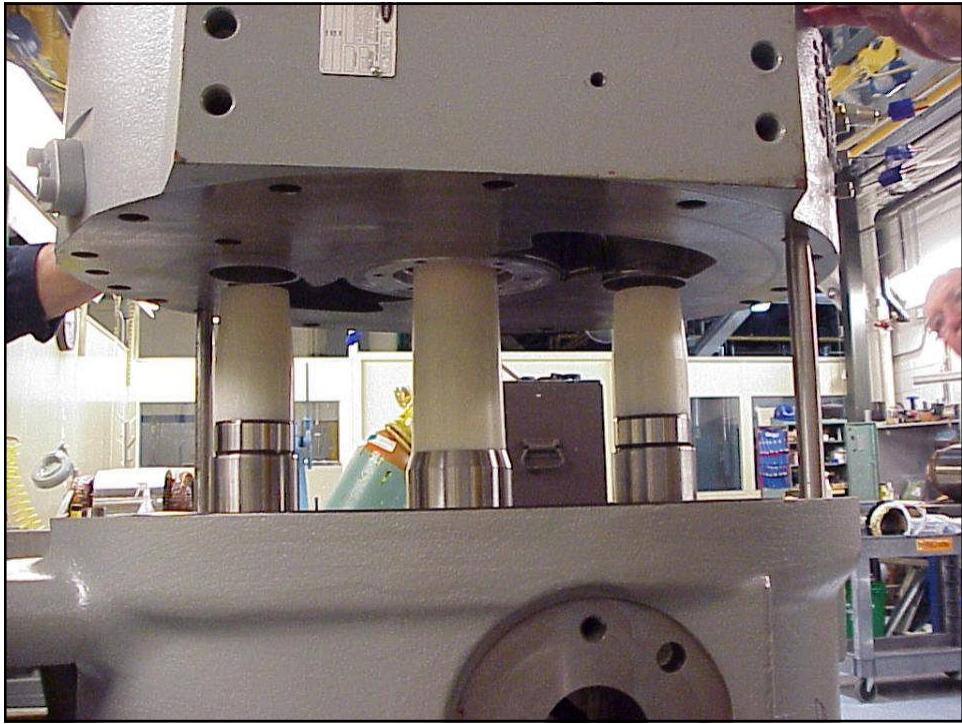

Copyright Carrier Corp. 2003

102.

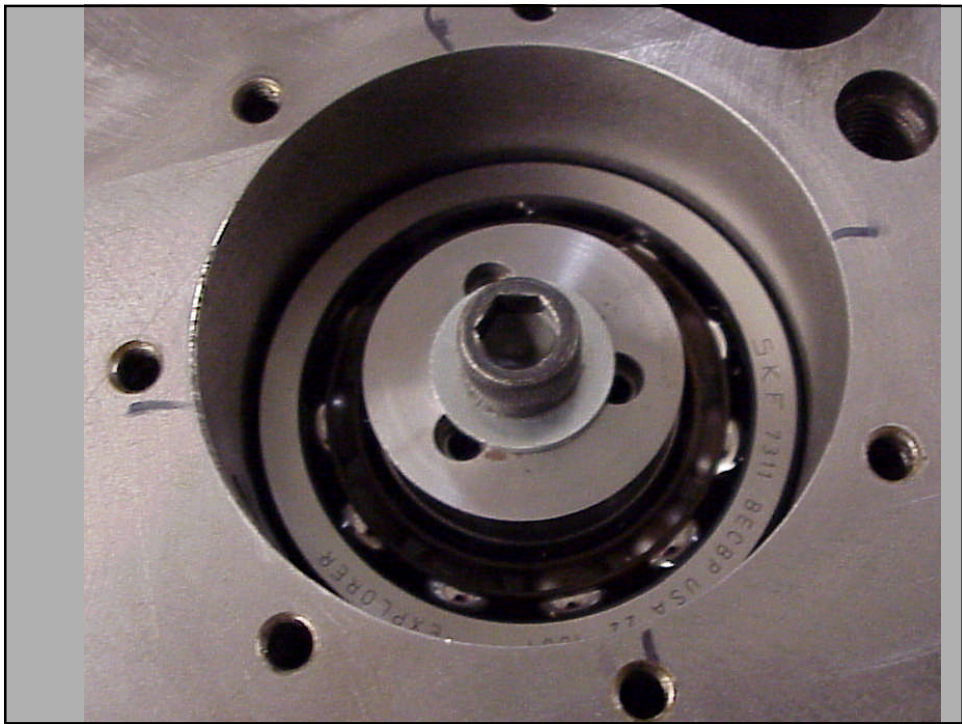

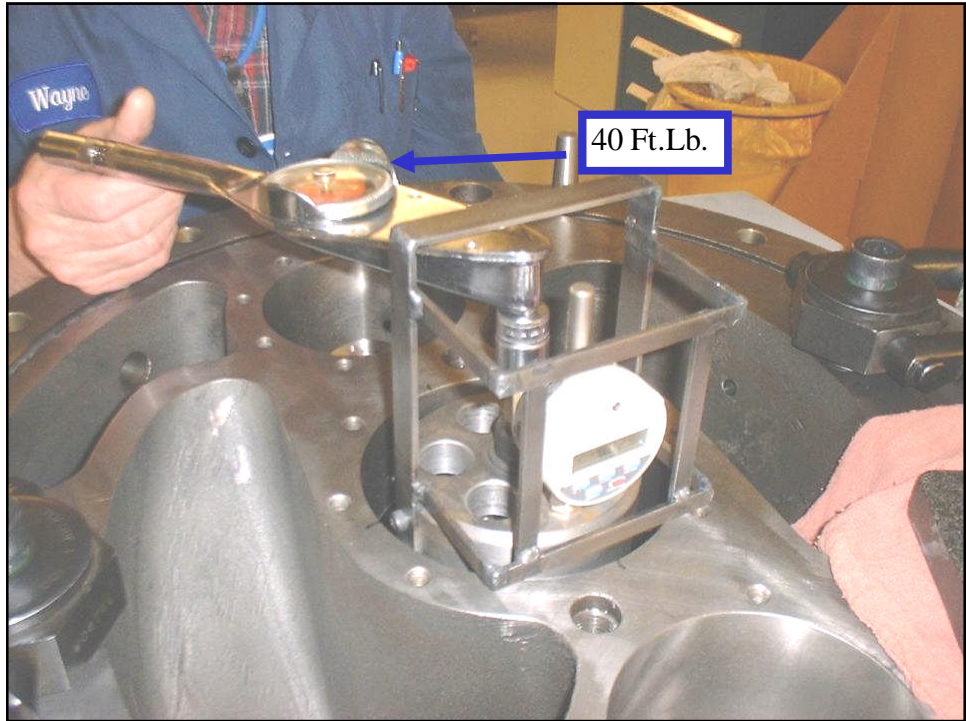

106.

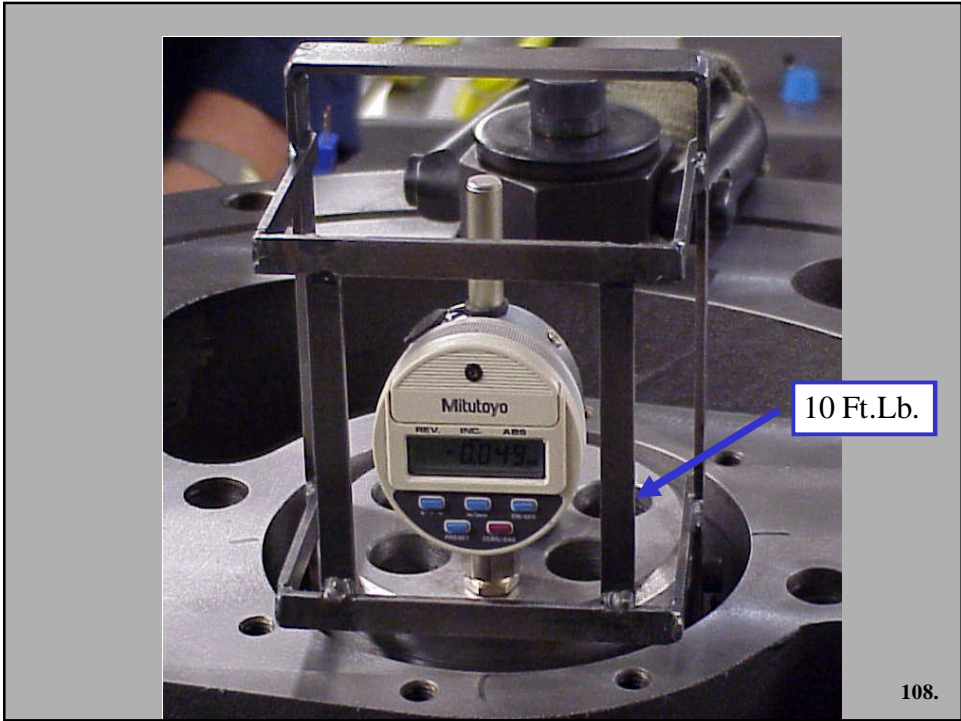
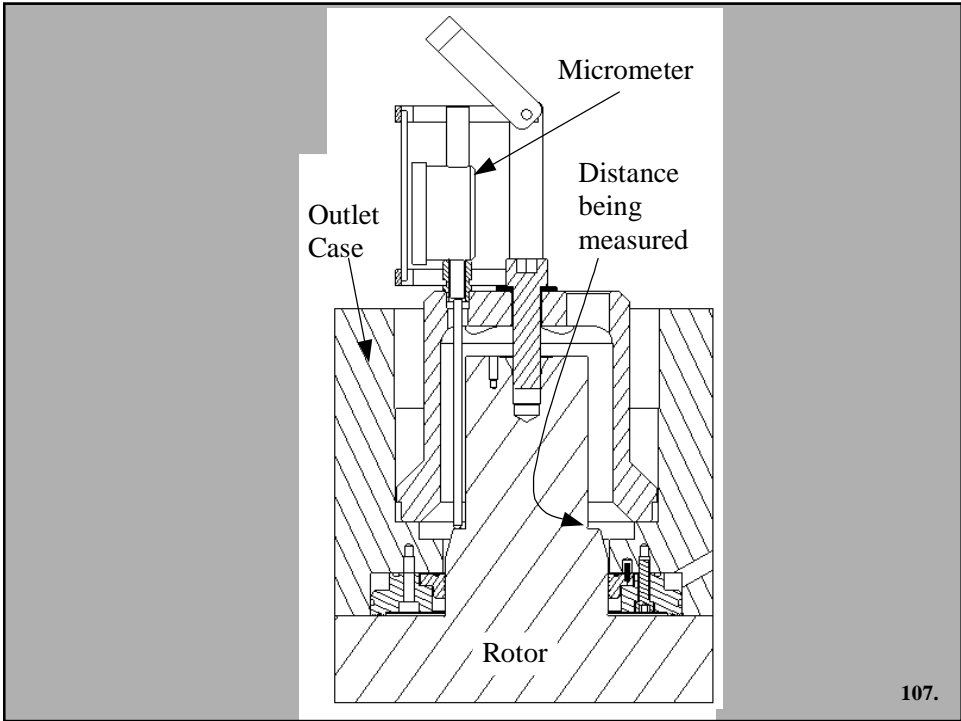

End Clearance Check Sheet						
<b>Top</b>	0	90	180	270	0	Average
	-0.079	-0.082	-0.078	-0.078	-0.08	-0.07925
<b>Male</b>	0	90	180	270	0	Average
	-0.059	-0.06	-0.061	-0.057	-0.06	-0.05925
<b>Bottom</b>	0	90	180	270	0	Average
	-0.084	-0.08	-0.083	-0.085	-0.084	-0.083
All Data						
	Top		Male		Bottom	
Gage meas. Average	-0.07925		Gage meas. Average	-0.05925	Gage meas. Average	-0.083
Clearance target	0.035		Clearance target	0.035	Clearance target	0.035
Target shim	0.11425		Target shim	0.09425	Target shim	0.118
To find the target shim, subtract the "Gage Measurement Average" from the "Clearance Target"						
Actual shim (measured)	0.1178		Actual shim (measured)	0.0952	Actual shim (measured)	0.1173
Theoretical end clearance	0.03855		Theoretical end clearance	0.03595	Theoretical end clearance	0.0343
To find the "Theoretical End Clearance, add the "Actual Shim (measured)" to the "Gage Measured Average"						
Act. end clr. (measured)	0.035		Act. end clr. (measured)	0.035	Act. end clr. (measured)	0.035
To find the "Actual End Clearance (measured)", find the average of the "Go" and "No Go" feeler gage measurements.						
<b>ERROR</b>			<b>ERROR</b>		<b>ERROR</b>	
Feeler gages used to verify	0.03 go		Feeler gages used to verify	0.03 go	Feeler gages used to verify	0.03 go
	0.04 no go			0.04 no go		0.04 no go
Shims used in build	1-none		Shims used in build	1- none	Shims used in build	1-none
	1- 4 notch			1-3 notch		1- 4 notch
Note: Taper detected by end clearance gage verified with feeler gages.						
Remember: The Gage meas. Average is most often negative. "Target Shim" = " Gage Meas. Average" - "Clearance target". Keep Track of signs!						

Copyright Carrier Corp. 2003

109.

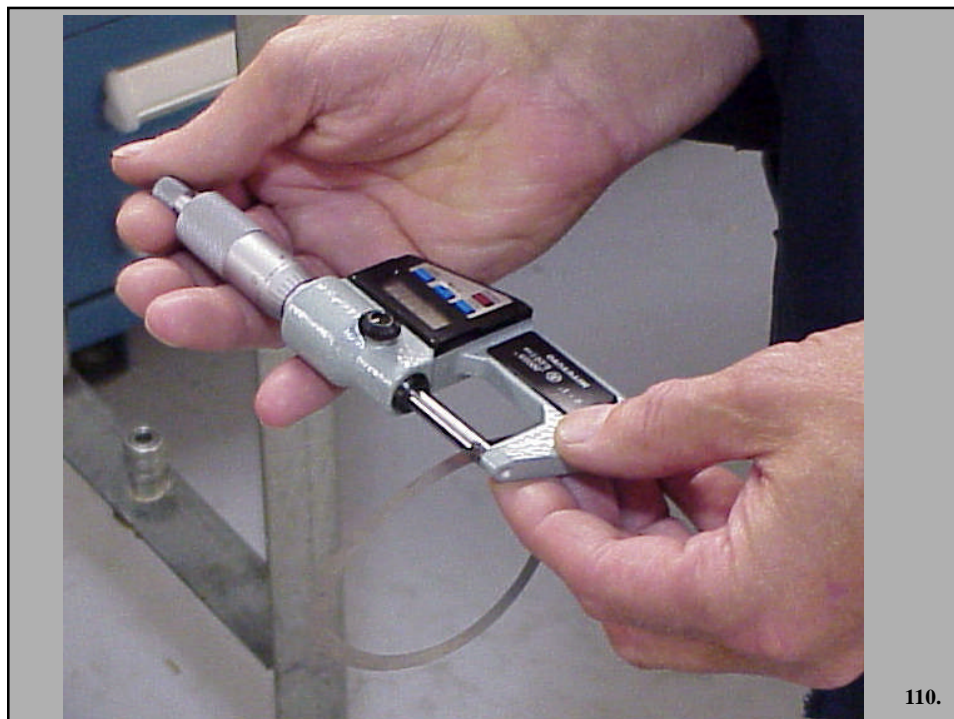

110.

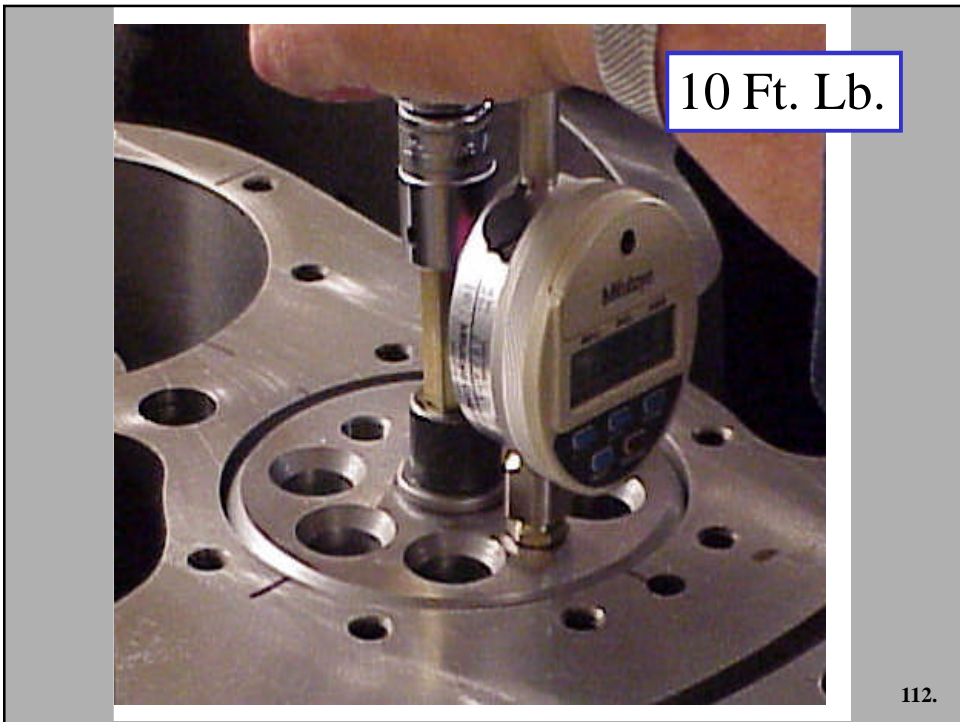
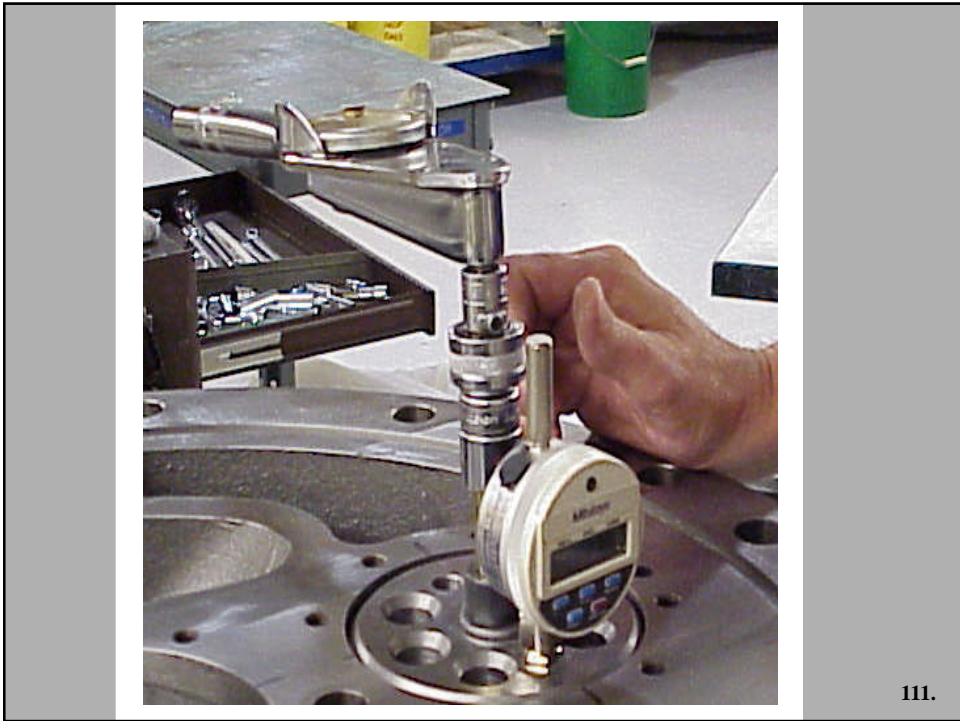

End Clearance Check Sheet						
<b>Top</b>	0	90	180	270	0	Average
	-0.079	-0.082	-0.078	-0.078	-0.08	-0.07925
<b>Male</b>	0	90	180	270	0	Average
	-0.059	-0.06	-0.061	-0.057	-0.06	-0.05925
<b>Bottom</b>	0	90	180	270	0	Average
	-0.084	-0.08	-0.083	-0.085	-0.084	-0.083
All Data						
	Top		Male		Bottom	
Gage meas. Average	-0.07925		Gage meas. Average	-0.05925	Gage meas. Average	-0.083
Clearance target	0.035		Clearance target	0.035	Clearance target	0.035
Target shim	0.11425		Target shim	0.09425	Target shim	0.118
To find the target shim, subtract the "Gage Measurement Average" from the "Clearance Target"						
Actual shim (measured)	0.1178		Actual shim (measured)	0.0952	Actual shim (measured)	0.1173
Theoretical end clearance	0.03855		Theoretical end clearance	0.03595	Theoretical end clearance	0.0343
To find the "Theoretical End Clearance, add the "Actual Shim (measured)" to the "Gage Measured Average"						
Act. end clr. (measured)	0.035		Act. end clr. (measured)	0.035	Act. end clr. (measured)	0.035
To find the "Actual End Clearance (measured)", find the average of the "Go" and "No Go" feeler gage measurements.						
<b>ERROR</b>			<b>ERROR</b>		<b>ERROR</b>	
Feeler gages used to verify	0.03 go		Feeler gages used to verify	0.03 go	Feeler gages used to verify	0.03 go
	0.04 no go			0.04 no go		0.04 no go
Shims used in build	1-none		Shims used in build	1- none	Shims used in build	1-none
	1- 4 notch			1-3 notch		1- 4 notch
Note: Taper detected by end clearance gage verified with feeler gages. Remember: The Gage meas. Average is most often negative. "Target Shim" = " Gage Meas. Average" - "Clearance target". Keep Track of signs!						

Copyright Carrier Corp. 2003

113.

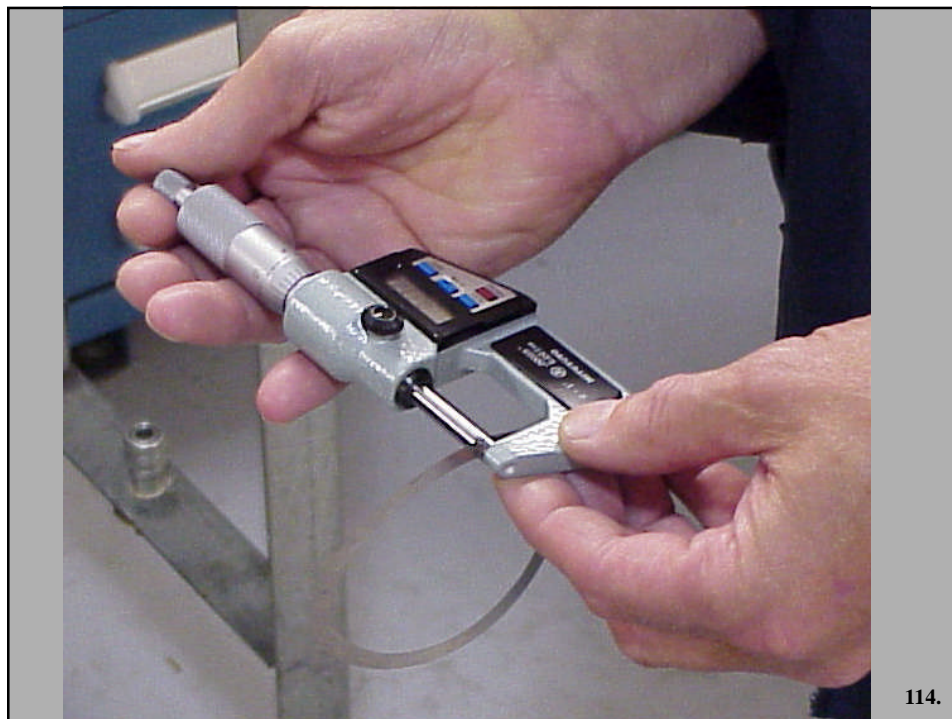

114.

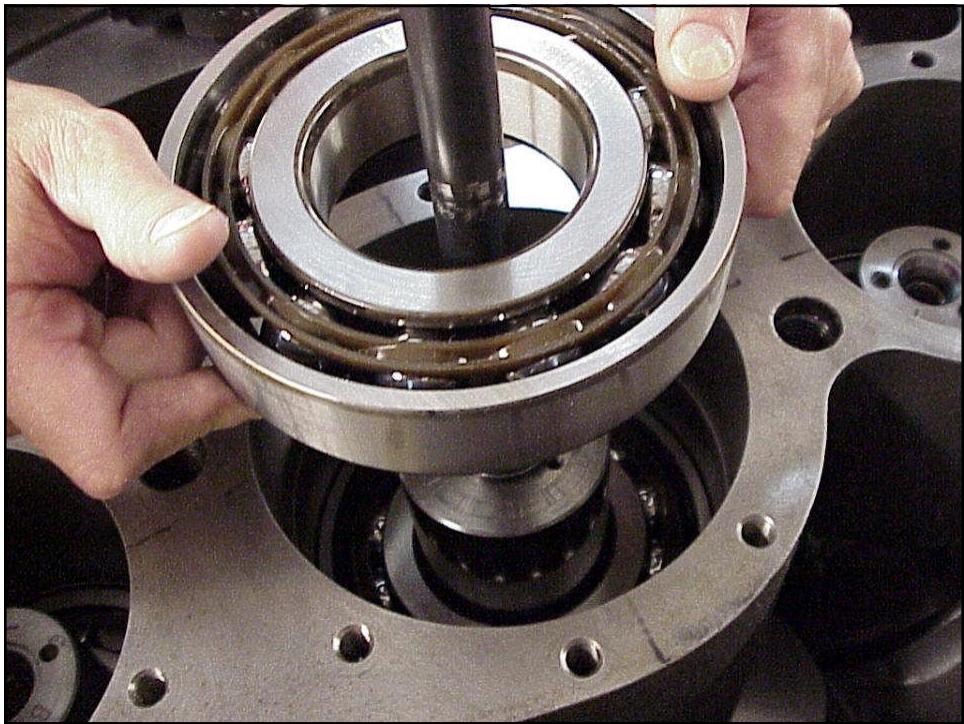



117.



118.

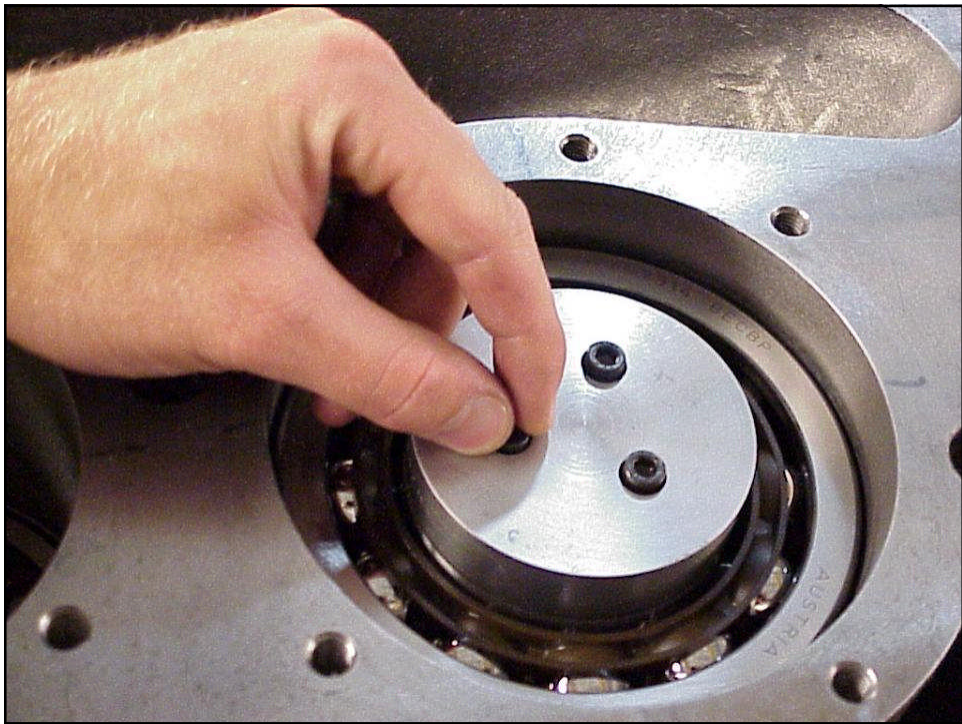
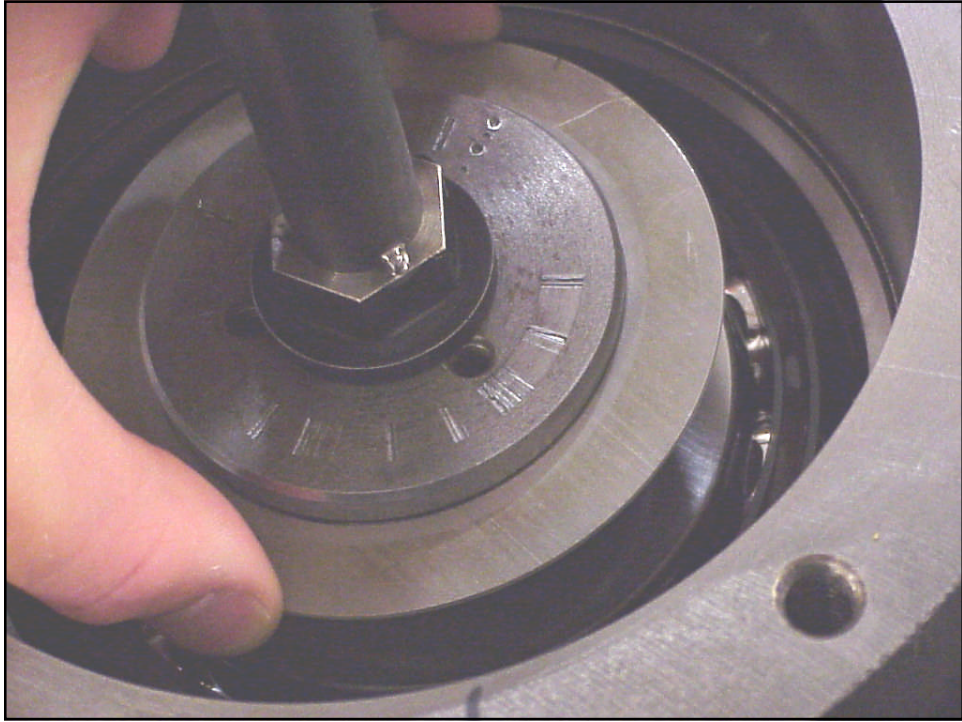

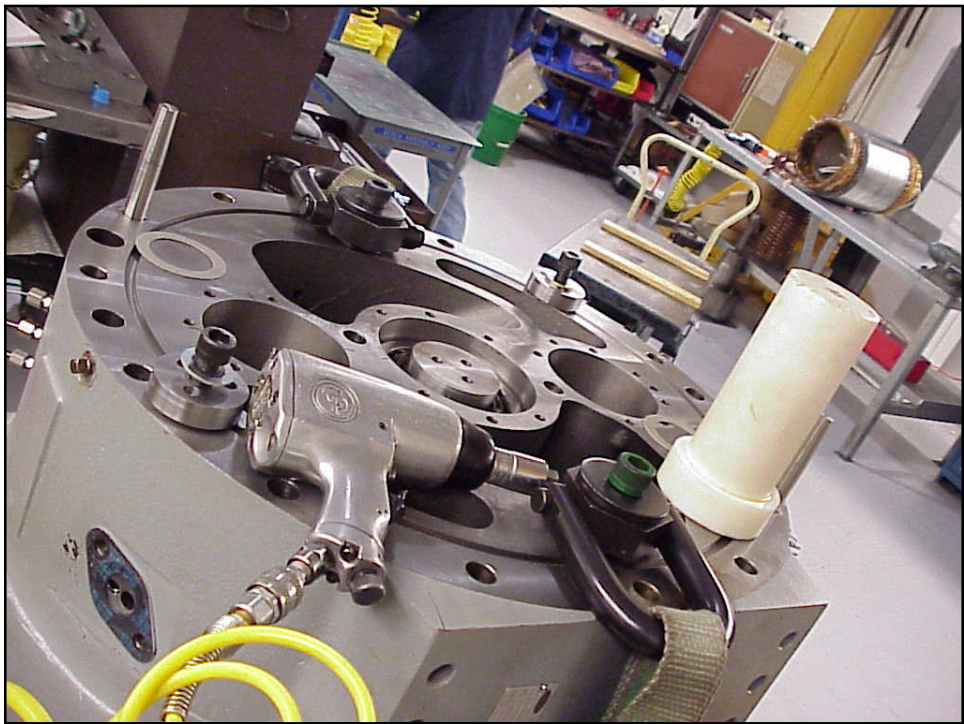
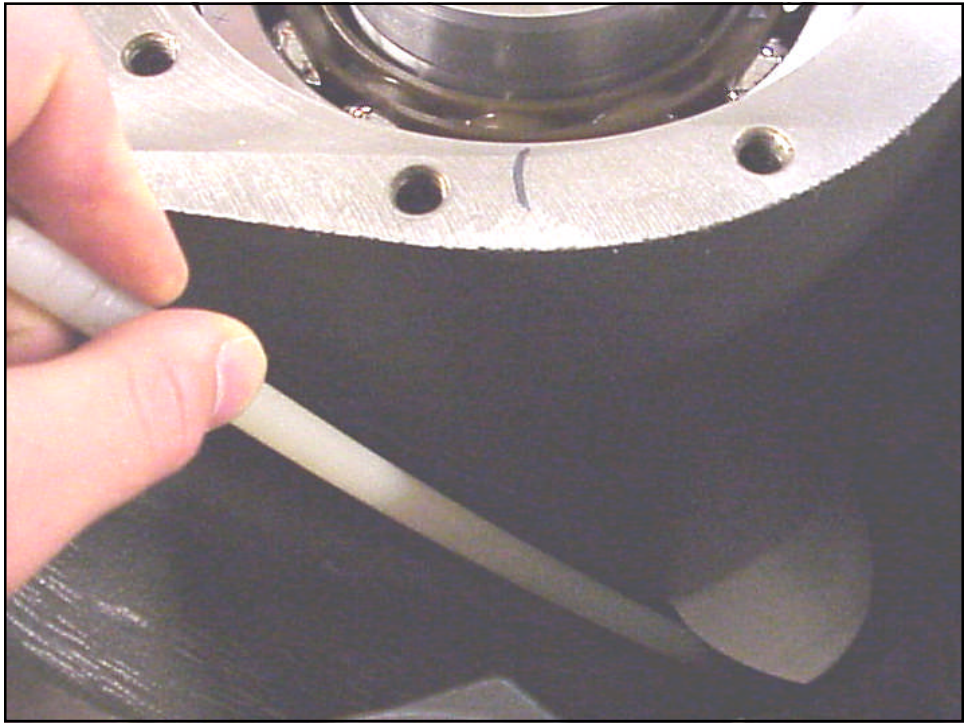



Shoot PIC of spacer

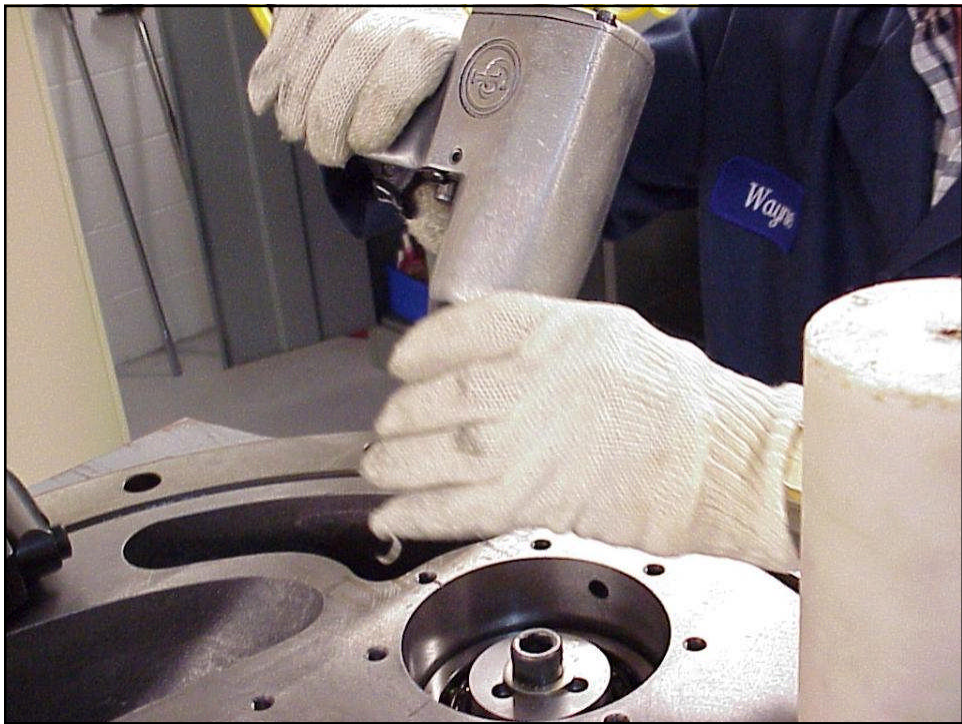

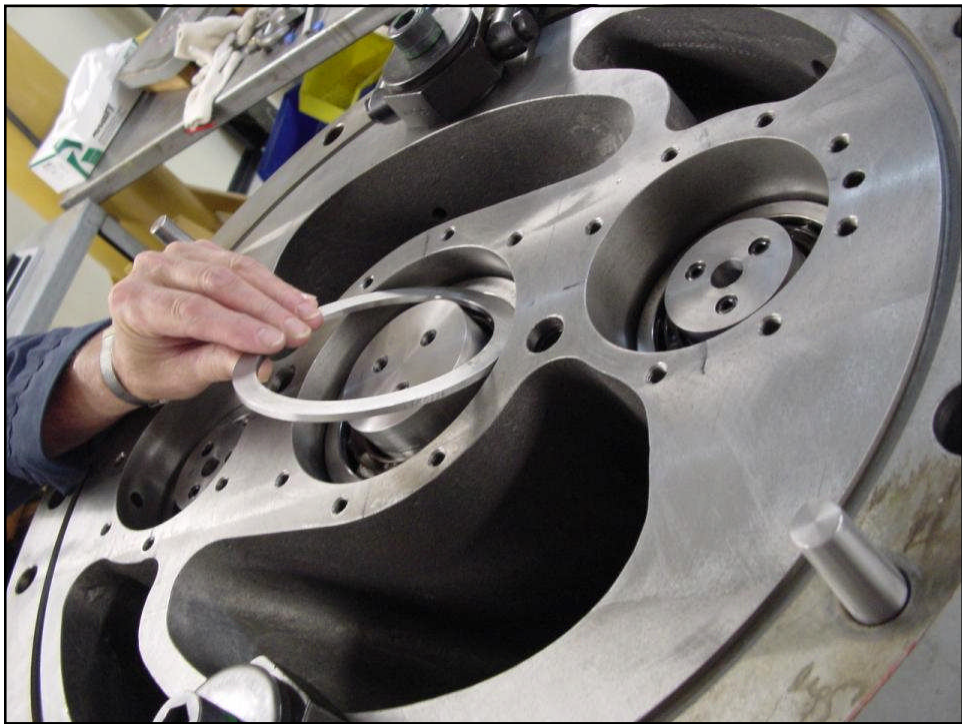
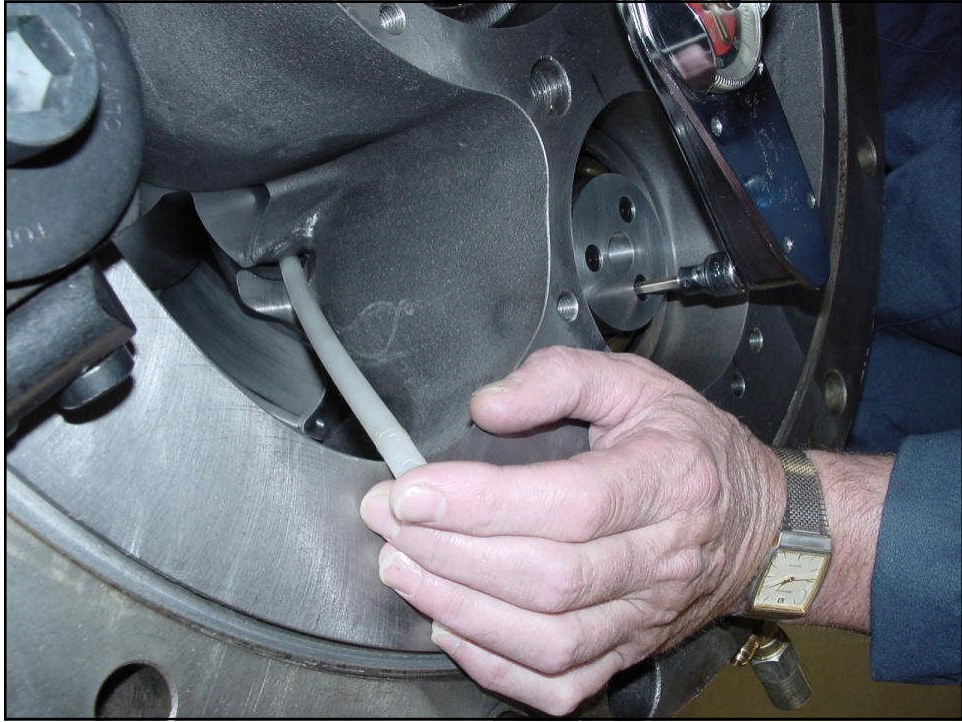

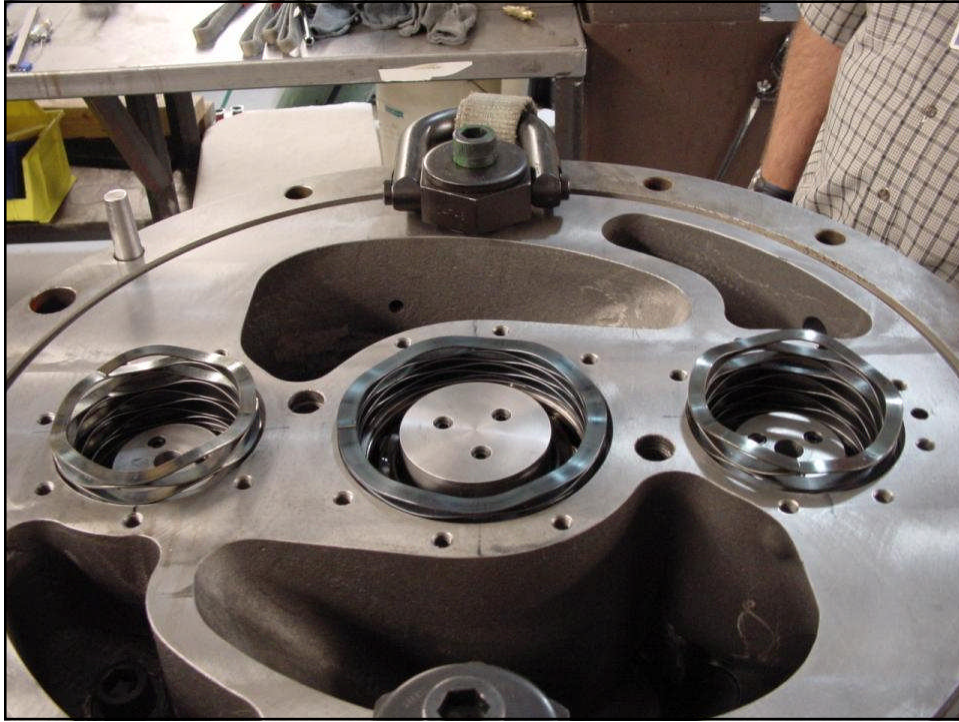

Bearing cover plate gasket

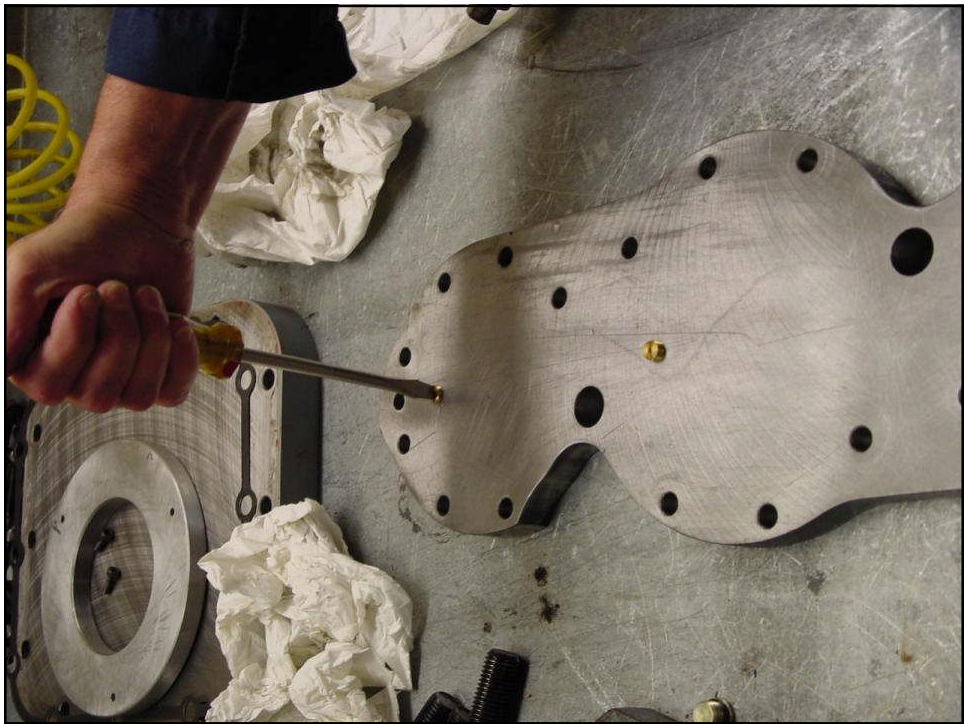
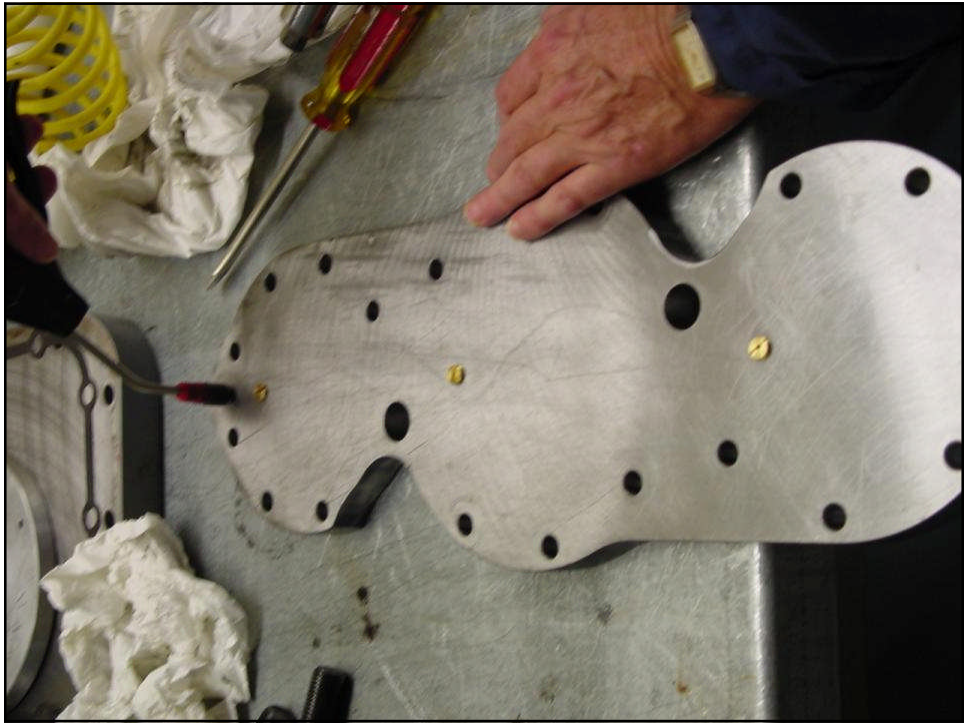

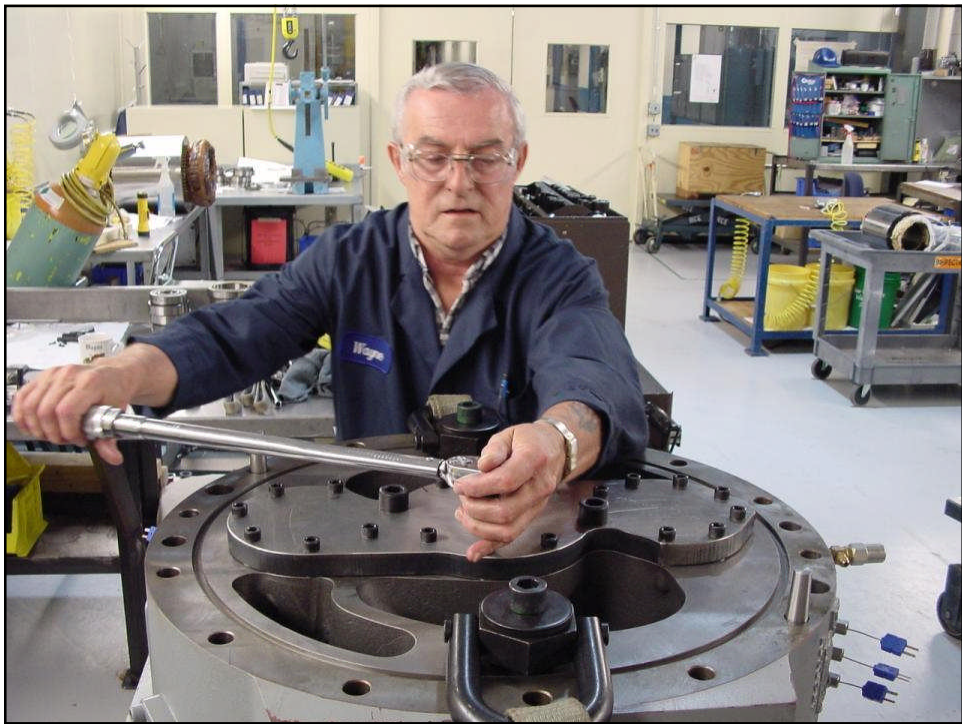
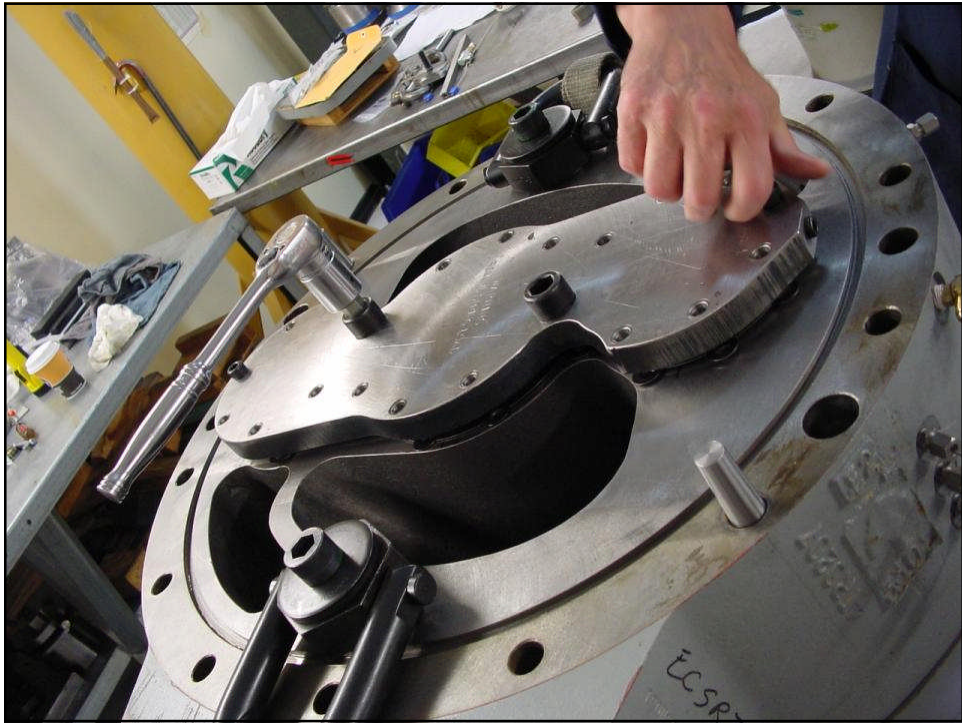



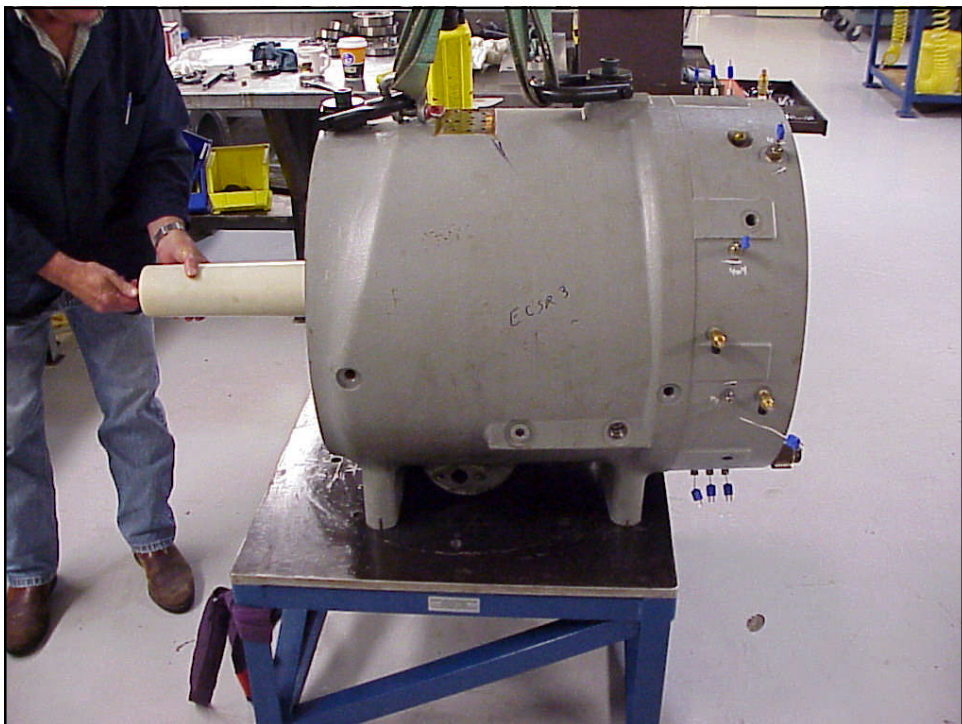
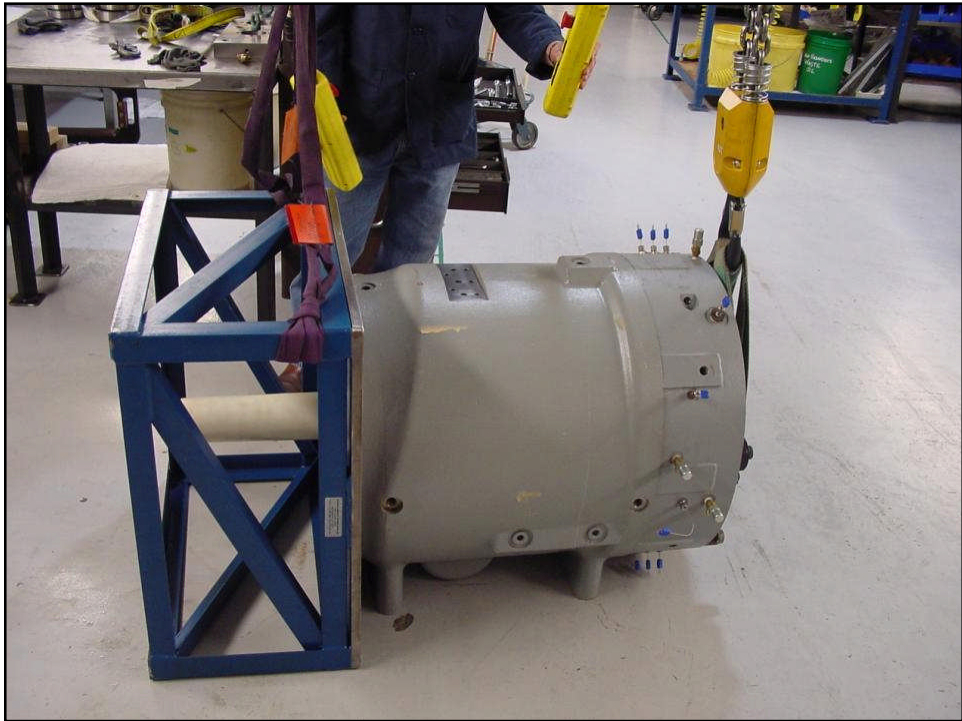

Oil the main bearing feed and  
rotate the male shaft

Copyright Carrier Corp. 2003

139.



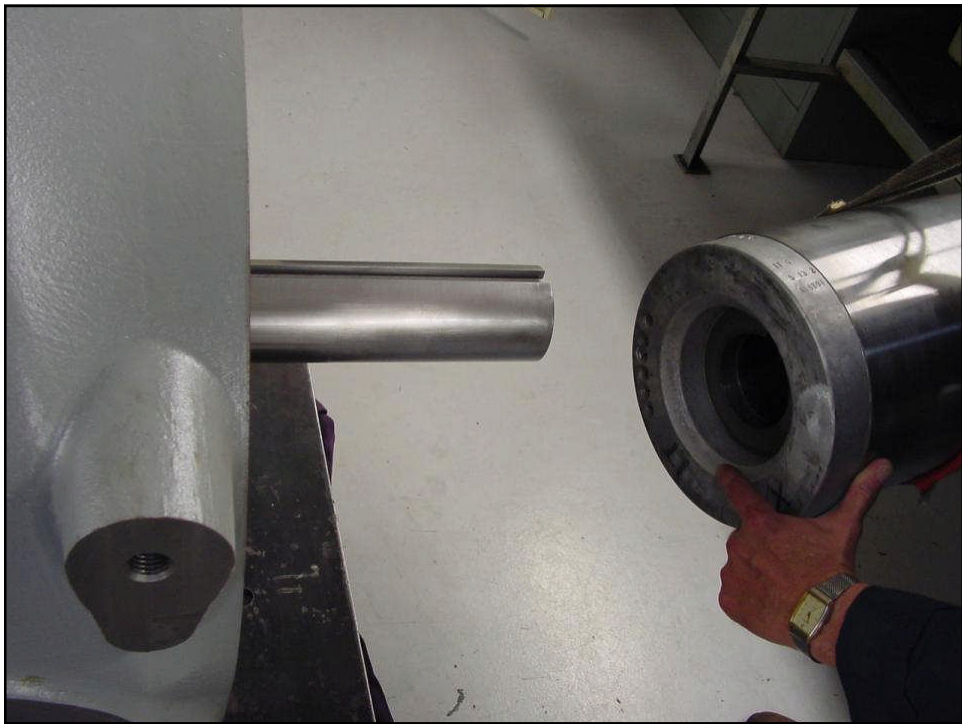
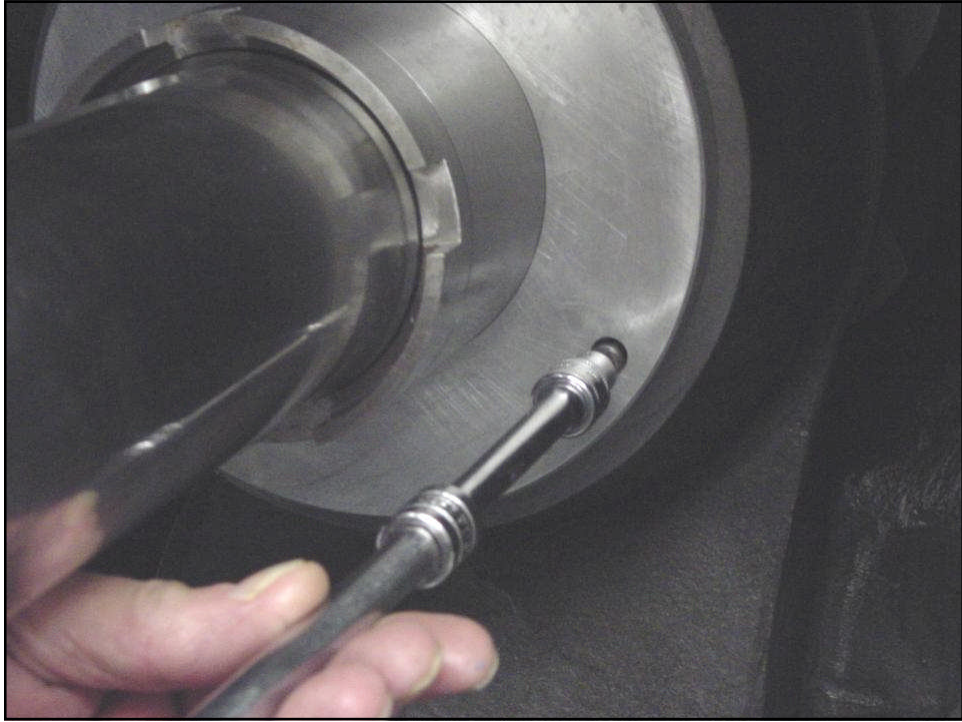

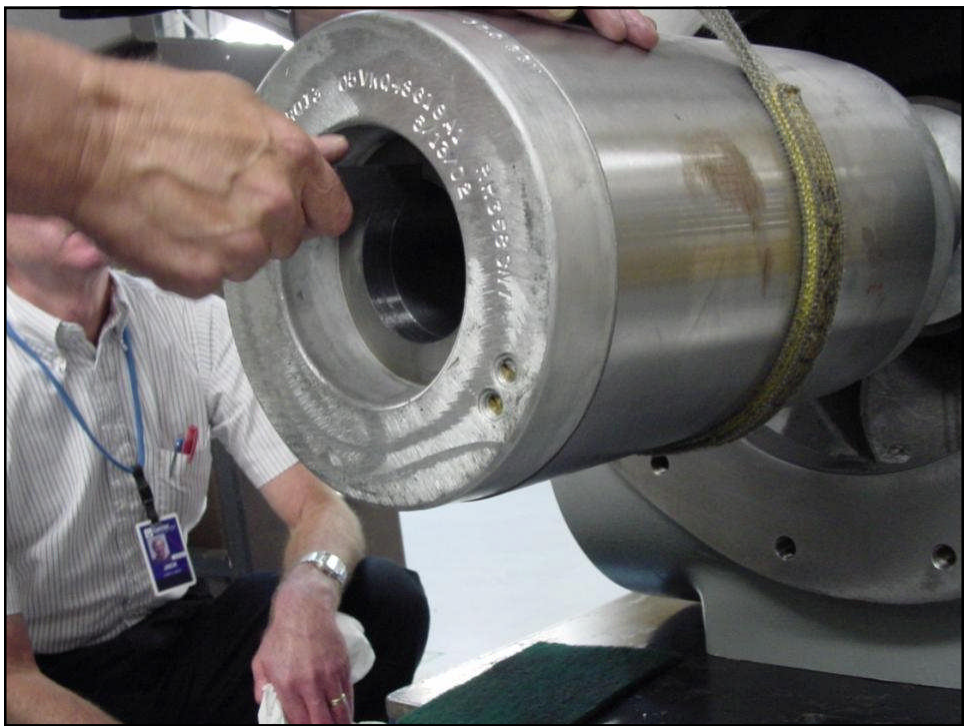
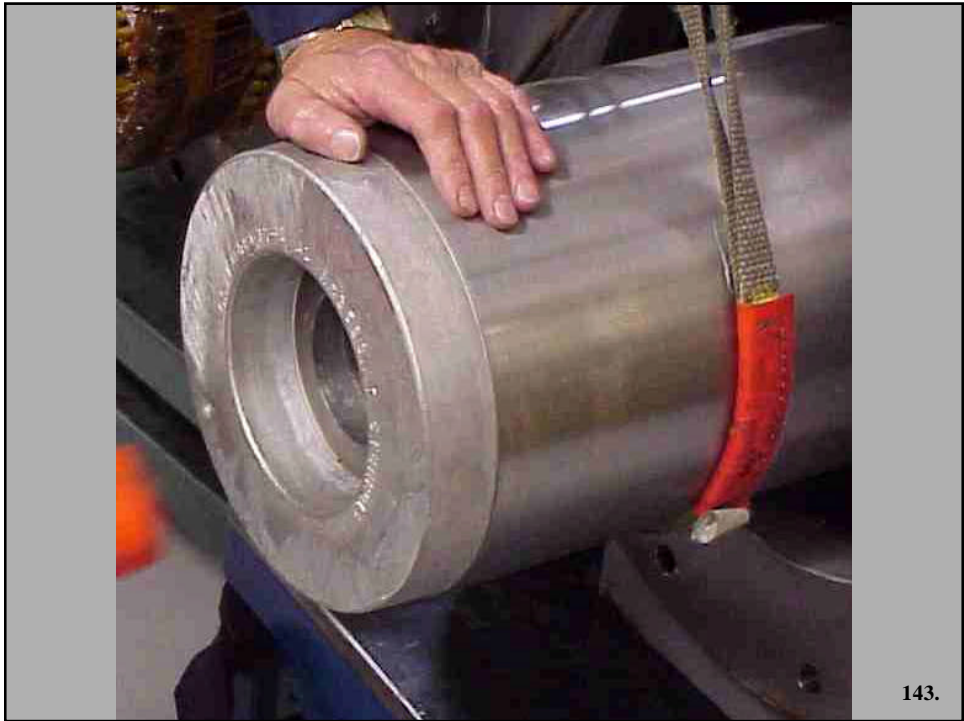

# Measure motor rotor runout

Copyright Carrier Corp. 2003

145.

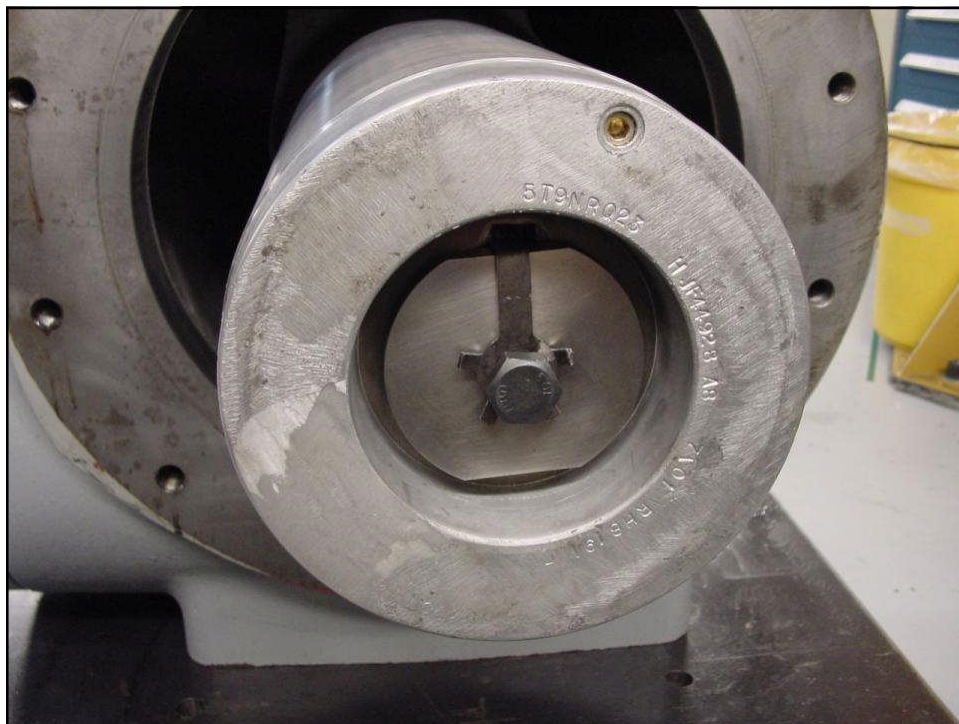

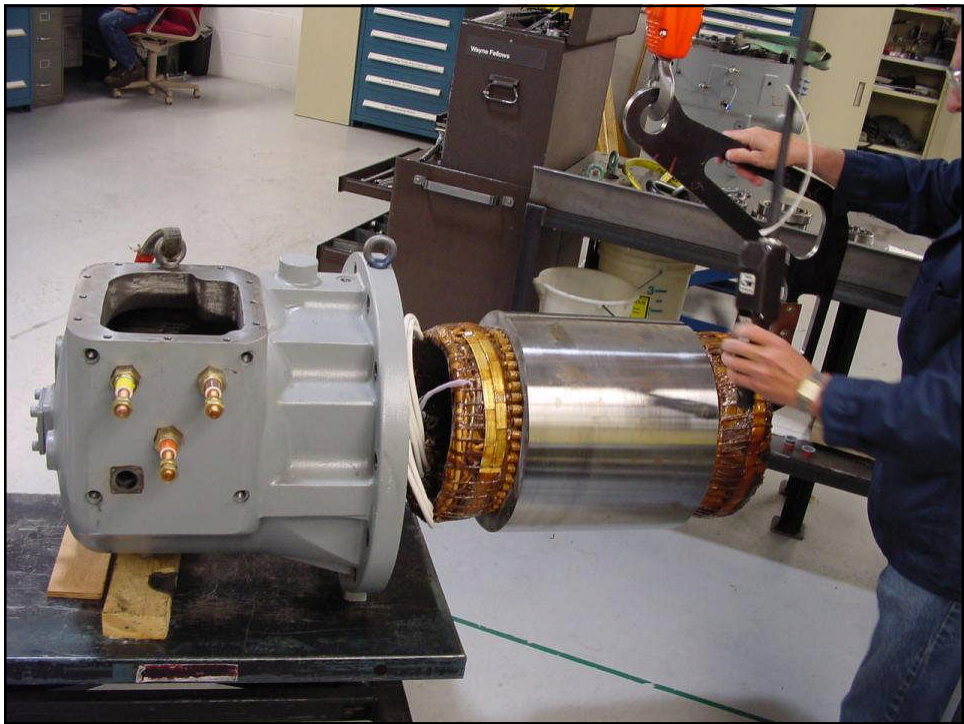



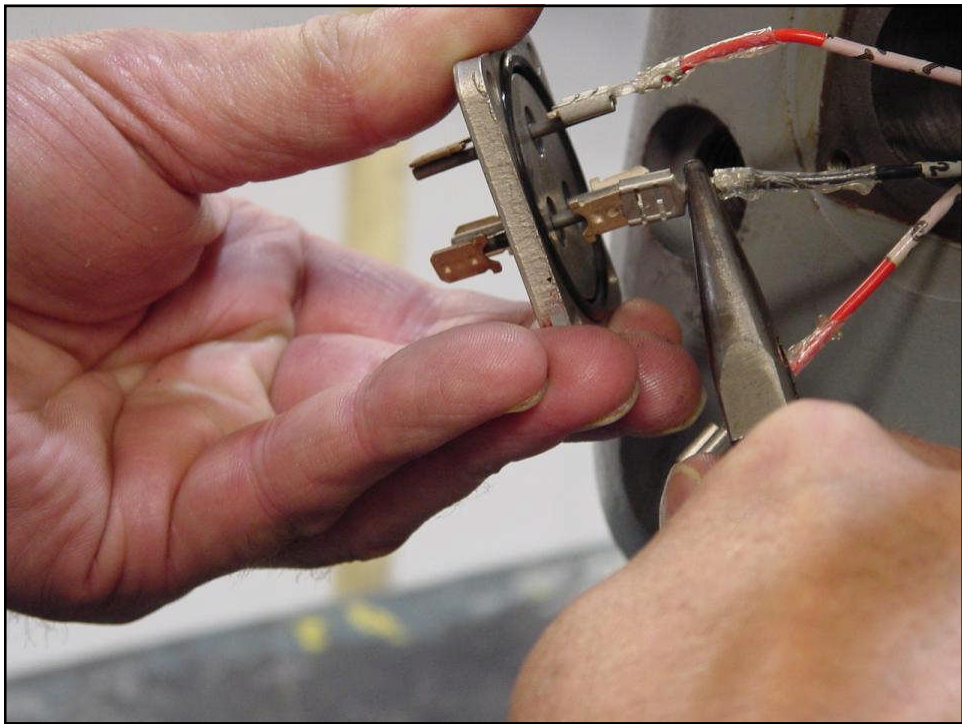
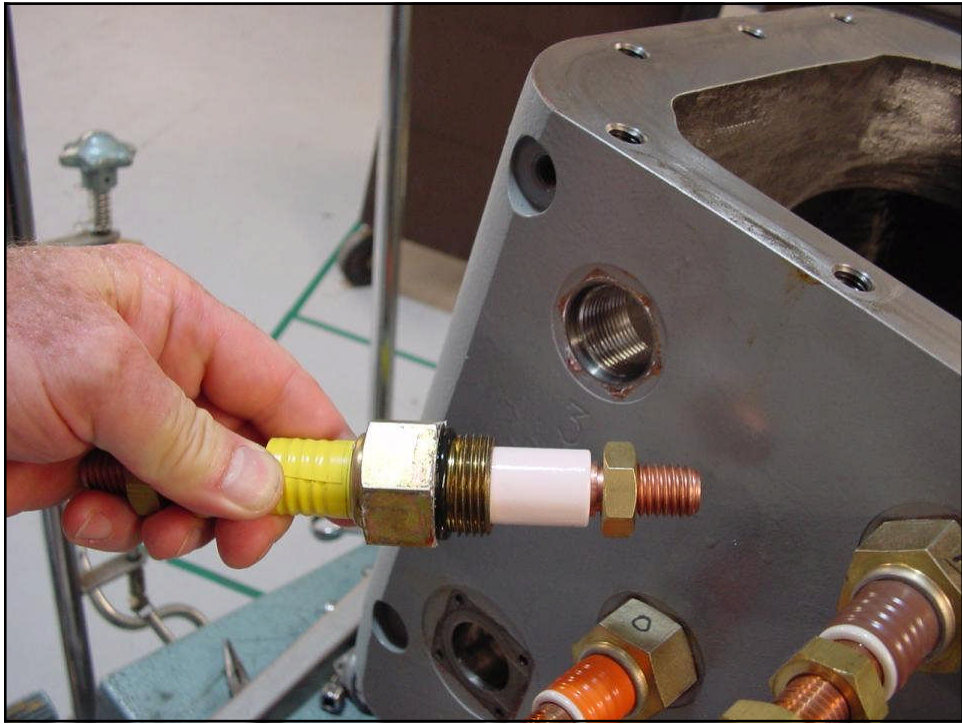

# Motor Wiring Schematic

## 1-6 - 24 & 3-5

Copyright Carrier Corp. 2003

153.

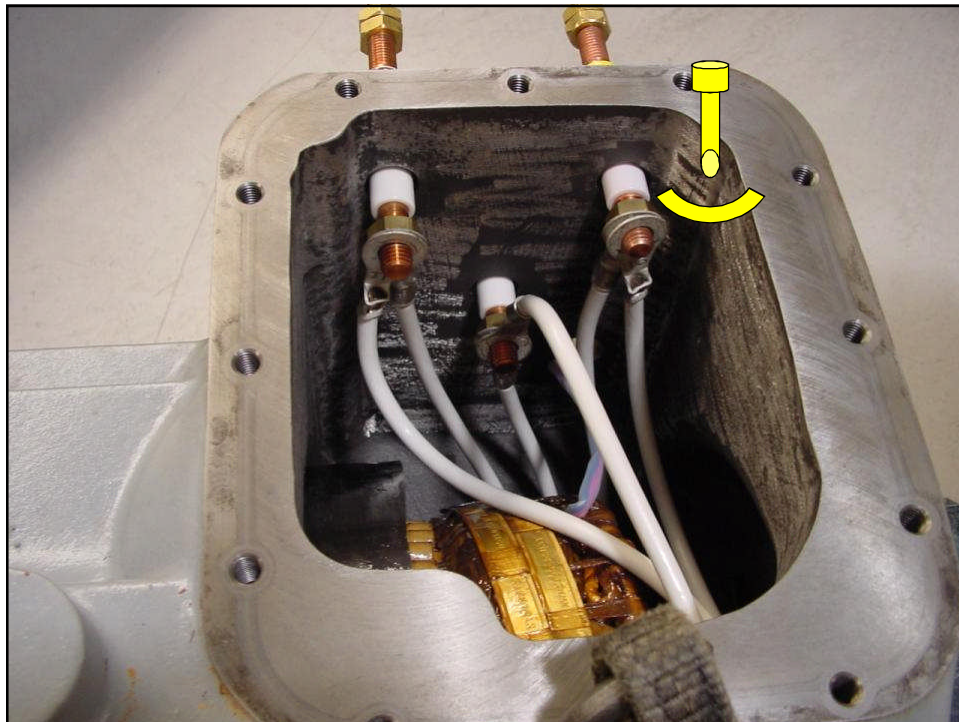

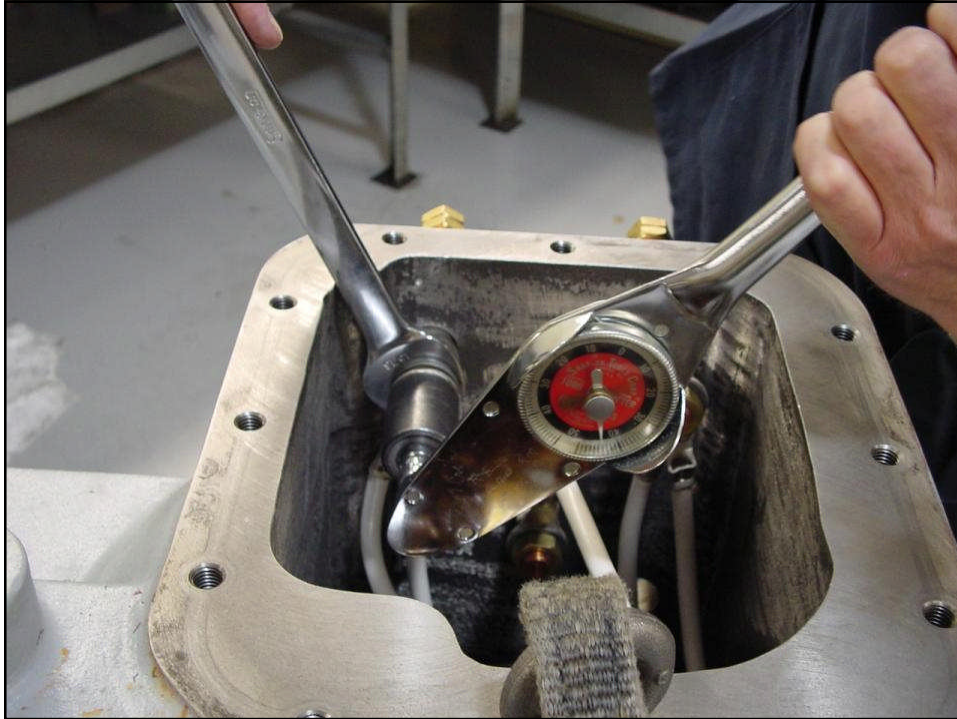

Use a ohmmeter to test motor windings to ground

Show how the testing of the  
resistance of motor windings  
for number 66

Copyright Carrier Corp. 2003

157.

Measure the thermistor  
resistance

Copyright Carrier Corp. 2003

158.

## Prepare for motor assembly - start with O-ring

Copyright Carrier Corp. 2003

159.

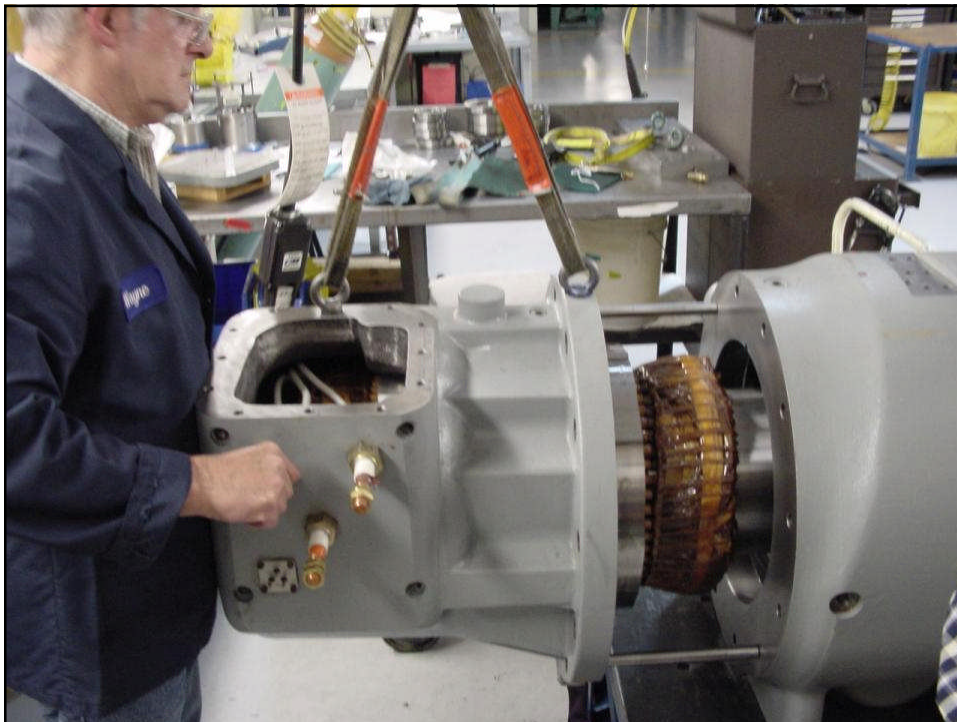



Check air gap

Hy-pot the motor

Copyright Carrier Corp. 2003

163.

Show where these holes are. Picture like you are just pulling out the SAE plug and show the threads with the O-rings

Copyright Carrier Corp. 2003

164.



## PIC Refrigerant spray nozzle

Copyright Carrier Corp. 2003

166.

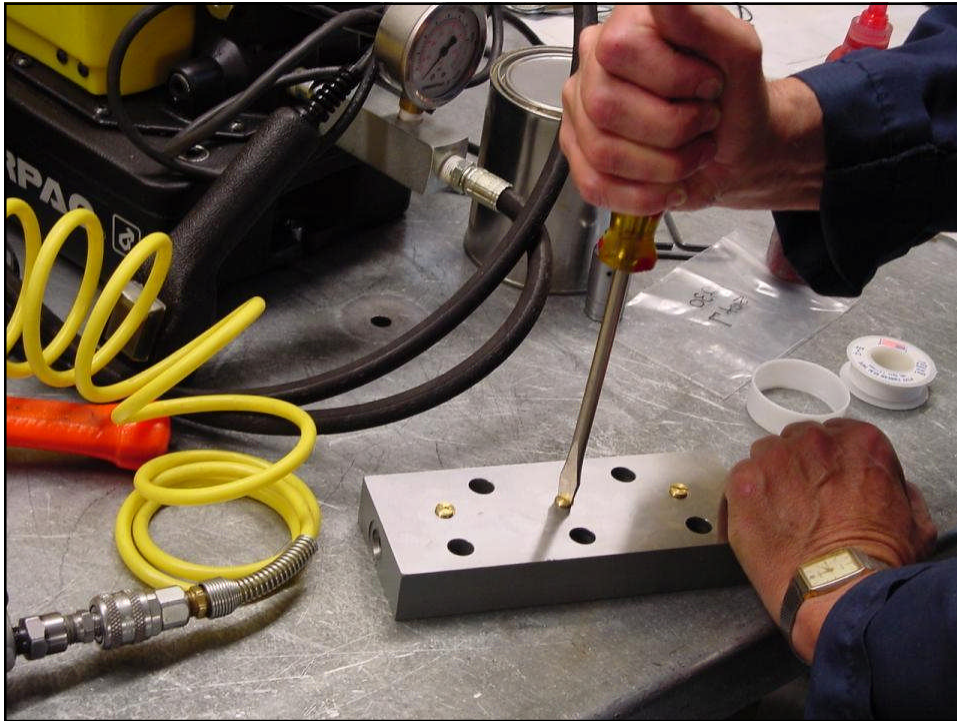

Install O - rings on lube block



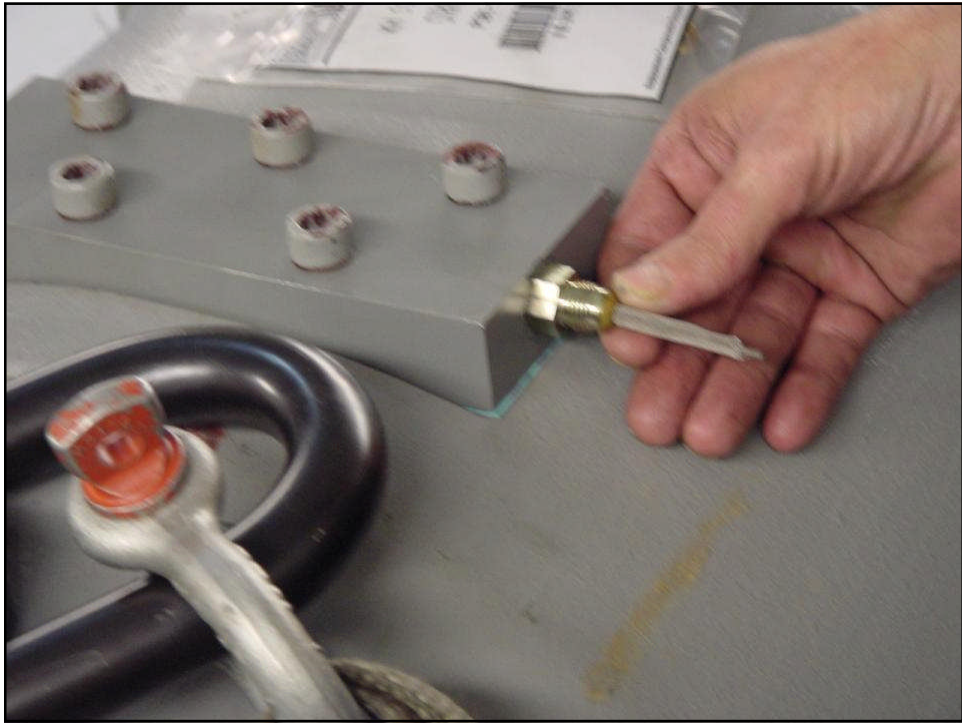

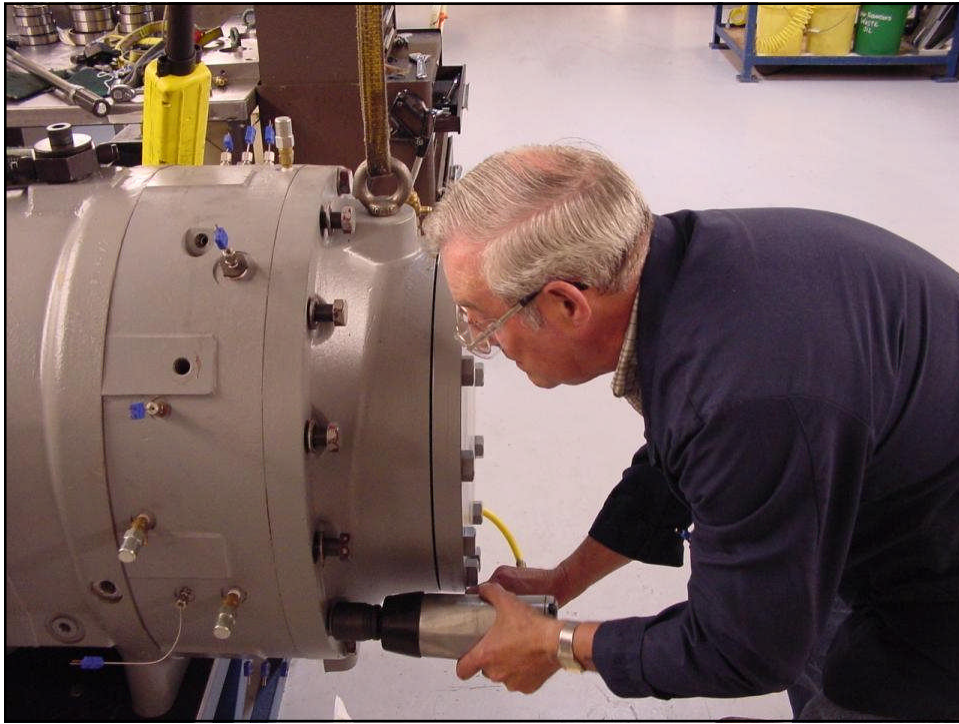

## Did I Mention SLIDE VALVES

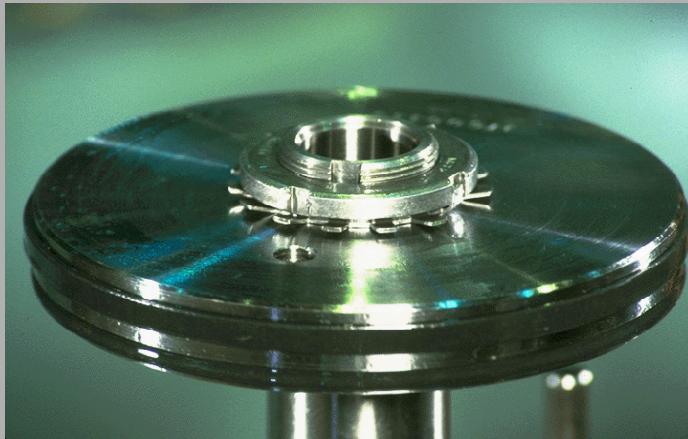

Copyright Carrier Corp. 2003