

# 23XRV (FOX FIRE) TRAINING

Control System Overview and Components

New I/O & Display Parameters

New Algorithms Familiarization

VFD Configuration

Alarms and Troubleshooting

**THIS PROGRAM AND PRESENTATION IS THE COPYRIGHTED WORK OF CARRIER CORPORATION AND IS INTENDED AND PROVIDED SOLELY FOR THE INTERNAL USE OF CARRIER CORPORATION.**

# 23XRV Control Center

(ICVC, Control Panel + VFD)

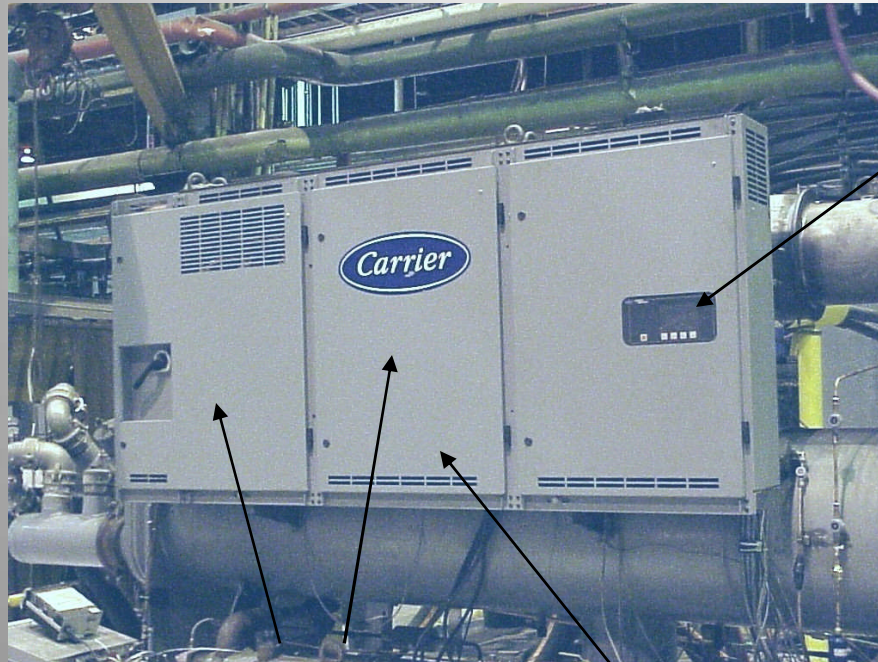

VFD (interlocked doors)

VFD schematic  
(behind door)

Chiller Control panel

ICVC

Back of ICVC

VFD nameplate

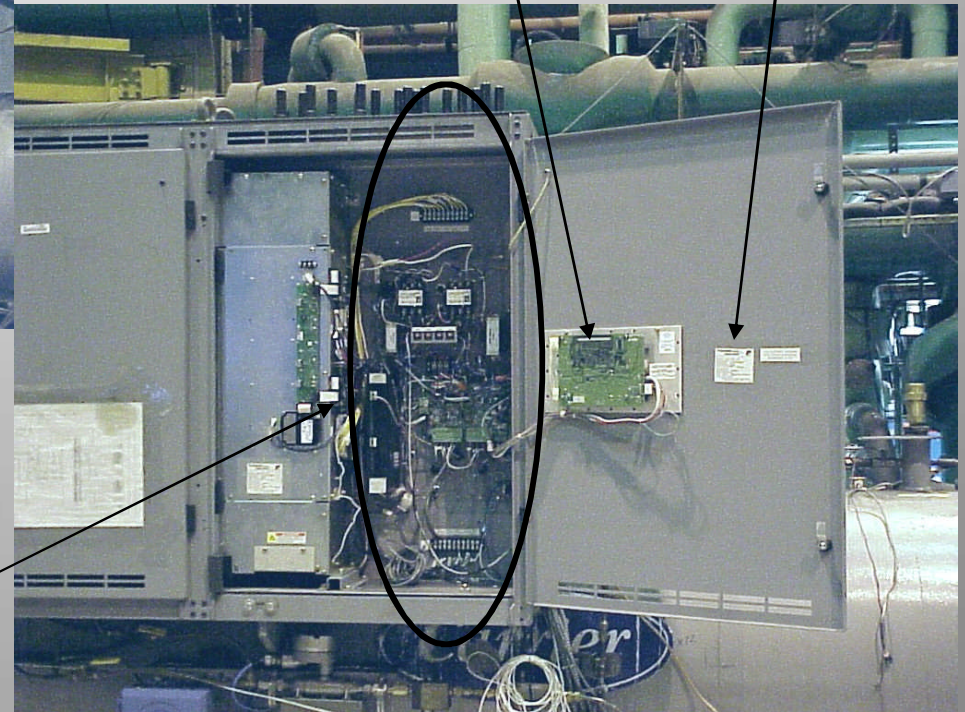

# 23XRV Control System Overview

- Chiller Control Center
  - Encloses the PIC-III Controls and VFD
- System Communications (Secondary Input/Output)bus -SIO
  - Links the ICVC, CCM, and Gateway
- ICVC – International Chiller Visual Control
  - Master of System and only Interface/Display
- CCM – Carrier Control Module
  - I/O for chiller components (typical)

# 23XRV Control System Overview

- VFG – Variable Frequency Gateway
  - Links VFD to SIO via the Drive Peripheral Interface (DPI) board
  - Embedded with CARRIER chiller protection algorithms
- VFD – Variable Frequency Drive
  - Motor control and protection, line/load metering
  - Field Wired Chiller Input/Output components controlled through A12 A/C Line I/O Board
- Network Interface
  - CCN ready, Dataport/Datalink for non CCN

# Comparison – Control System Communications

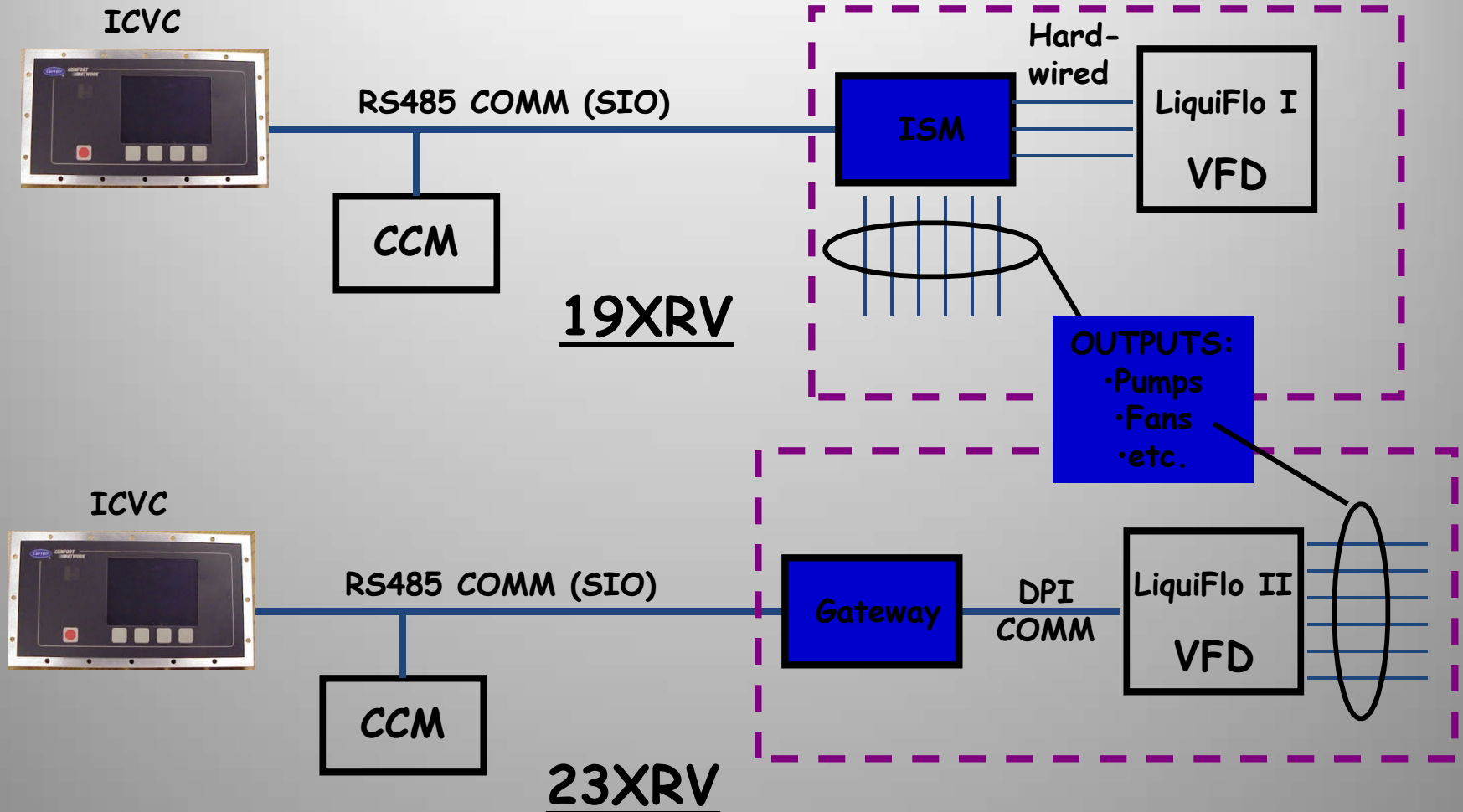

# VFD Communications Boards

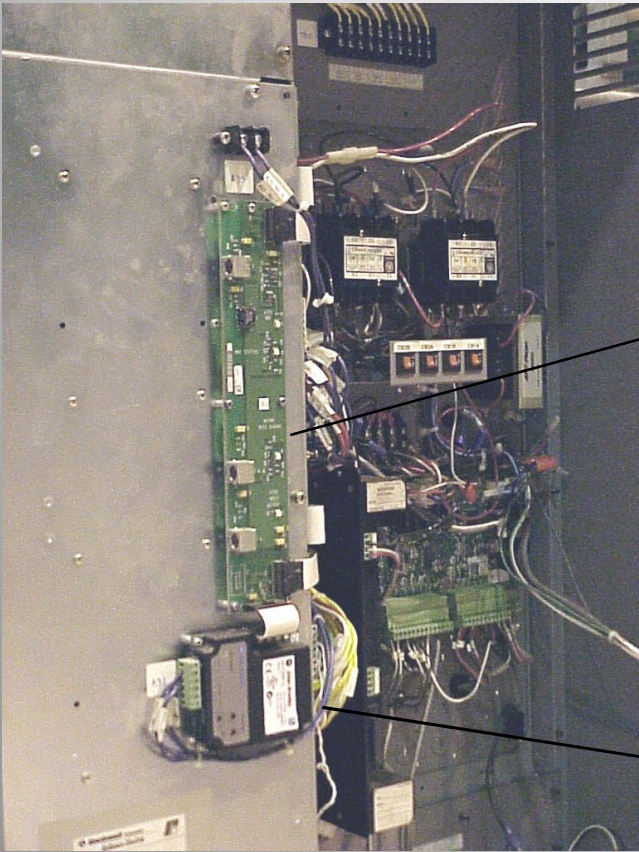

**Mounting in Chiller  
Control Center**

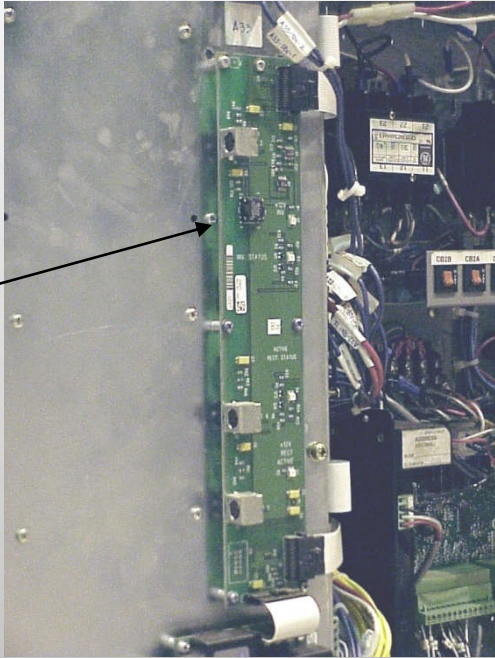

**DPI Board**

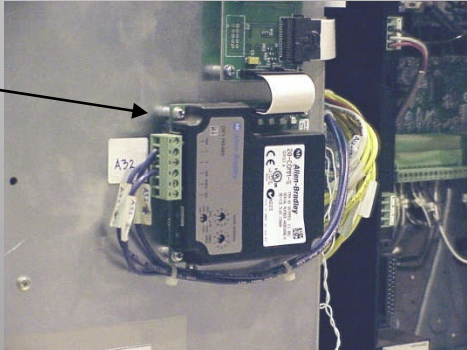

**VFG  
(Gateway)**

# 23XRV VFD with Control Panel Interface

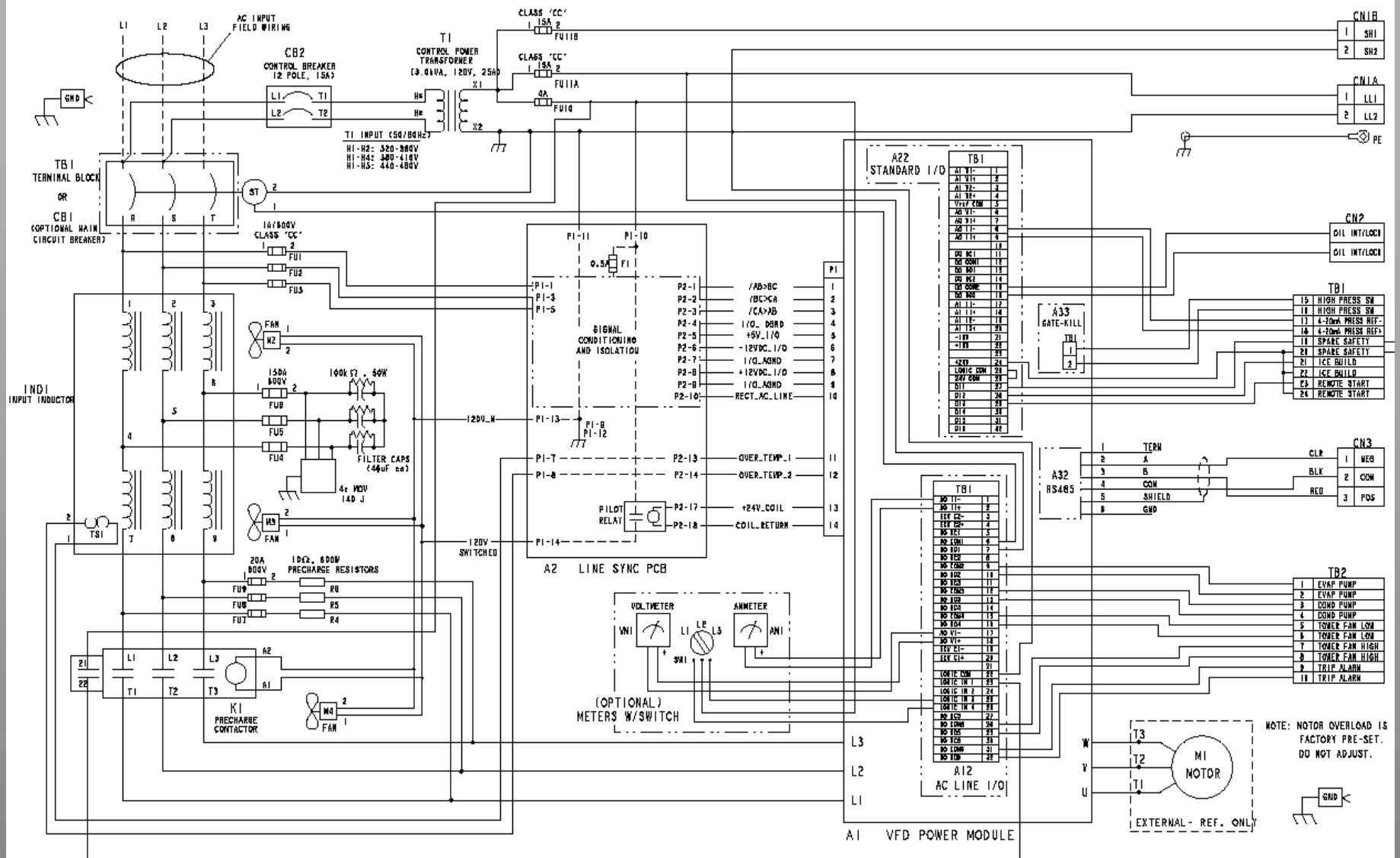

FOR TECHNICAL SUPPORT CALL 1-800-726-8112

# 23XRV Chiller Control System

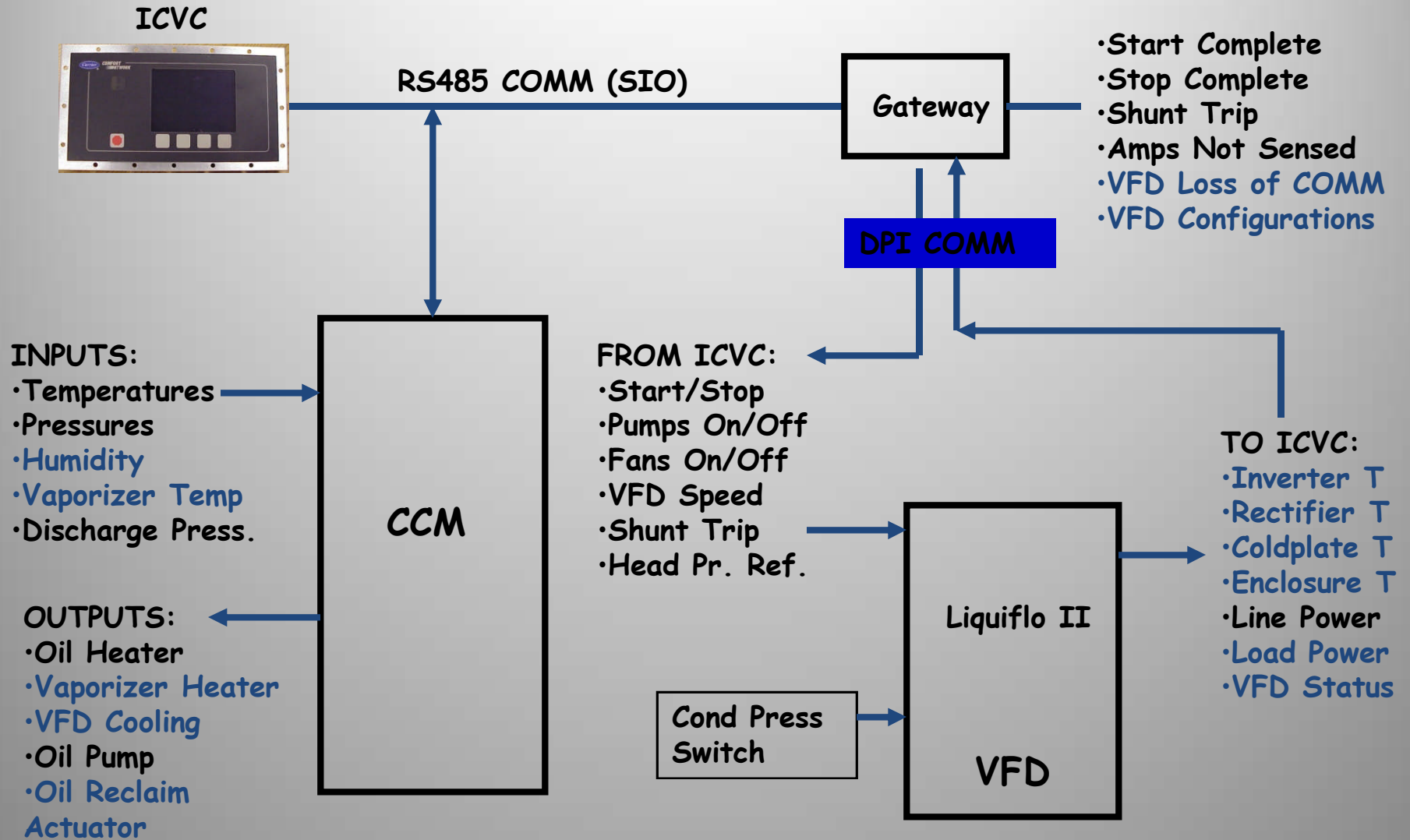

# 23XRV Control panel

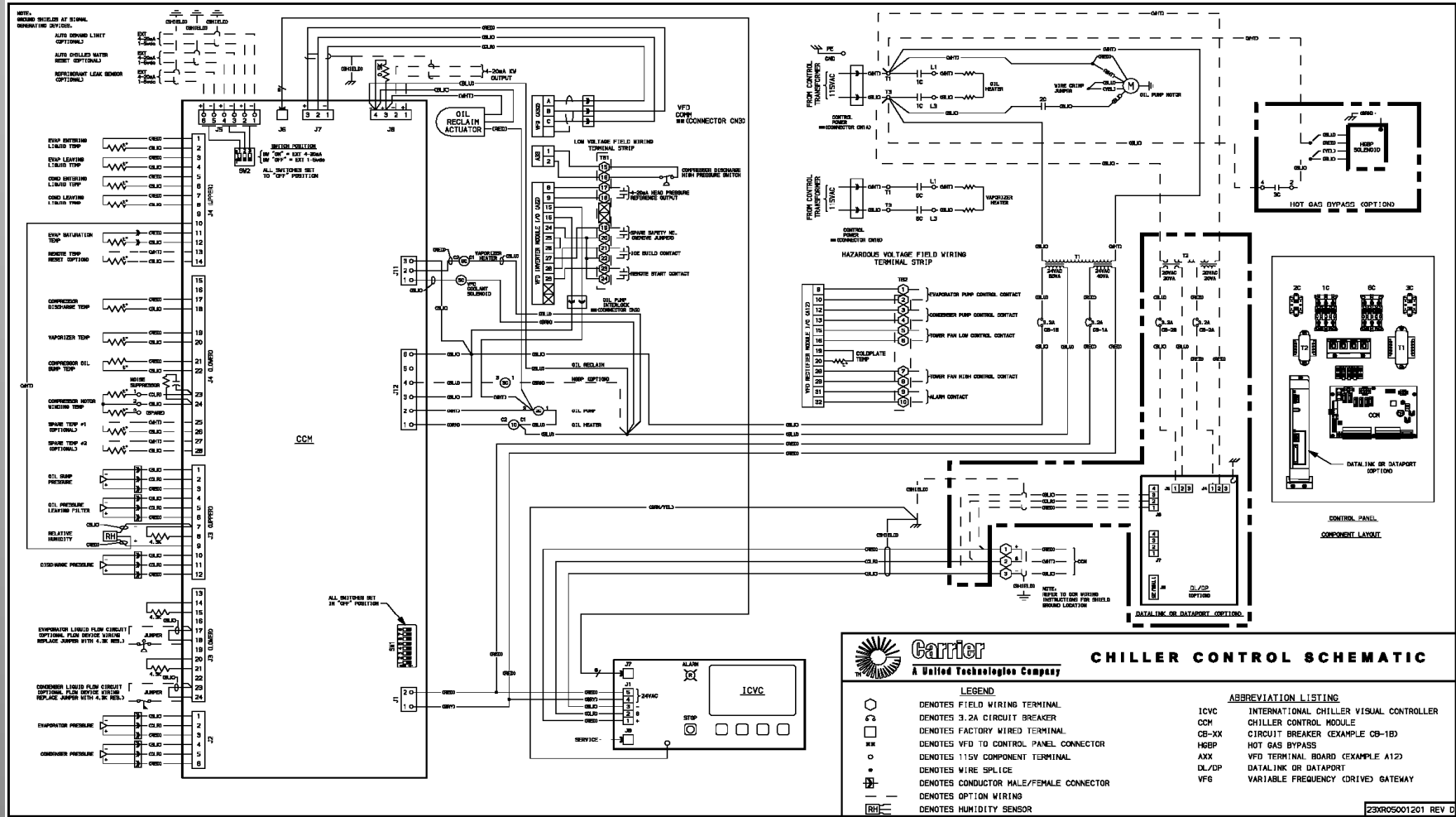

# New CCM Control Inputs

- **Evaporator Saturation Temperature (J4-11,12)**
  - Used for Evaporator Freeze Protection, Evaporator Approach, Oil Viscosity Calculation
- **Vaporizer Temperature (J4-19,20)**
  - Used for Reclaim Delta T Calculation
- **Relative Humidity (J3- 7,8,9 & J4-10)**
  - Used for Dewpoint Temp Calc
- **Compressor Discharge Pressure (J3-10,11,12)**
  - Used for Reverse Rotation Protection (Startup)

# New VFD Control Inputs

- Inverter Temperature (VFD Drive Module Board)
  - Used for Prestart, Override, VFD Protection
- Rectifier Temperature (VFD Drive Module Board)
  - Used for Prestart, Override, VFD protection
- Enclosure Temperature (VFD Rectifier Control Board)
  - Used for Dewpoint Temperature Calculation
- Coldplate Temperature (AC Line I/O -19,20)
  - Used for VFD Dew Prevention/Protection
- High Cond Pressure (A33-1,2 Gate-kill)
  - Used for High Condenser Pressure Trip  
(VFD disable)

# 23XRV Oil/Lube System

**Compressor  
Motor RPM**

**Vaporizer  
Temperature**

**Oil Heater**

**Oil Sump  
Pressure**

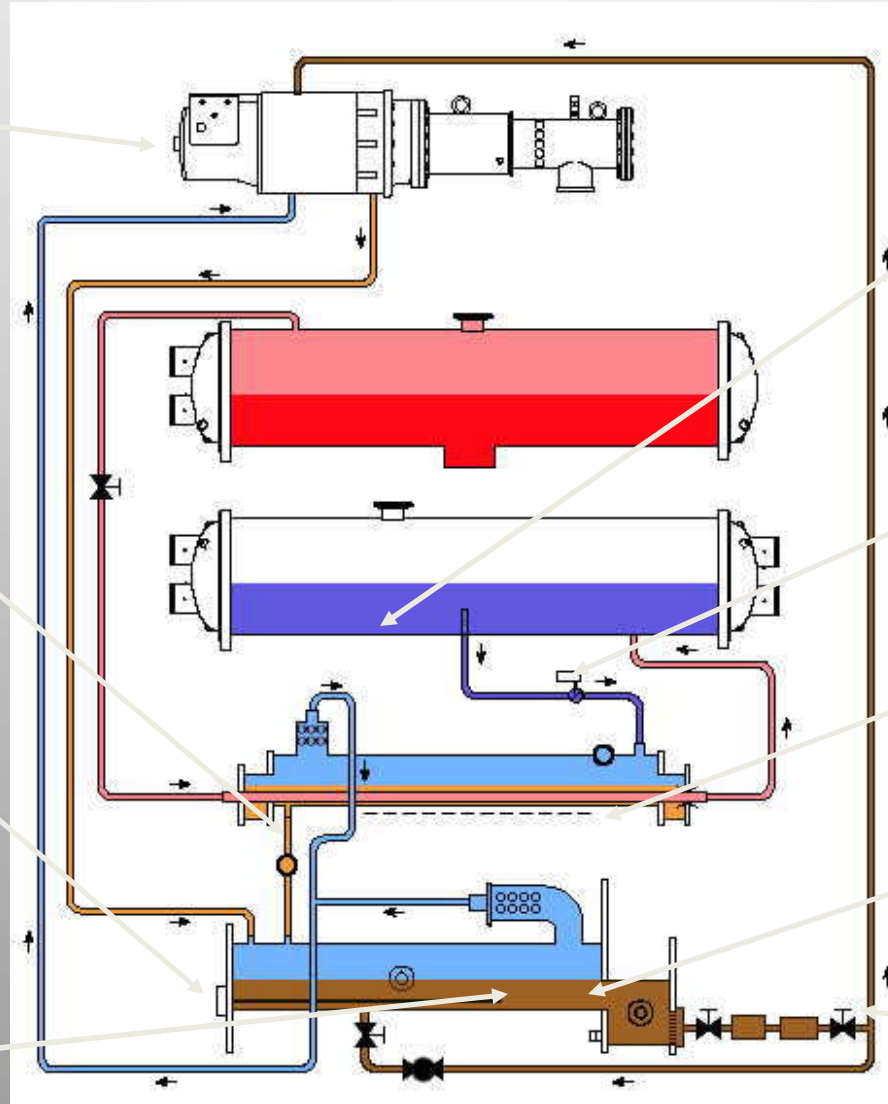

**Evaporator  
Saturation  
Temperature**

**Oil Reclaim  
Output**

**Vaporizer  
Heater**

**Oil Sump  
Temperature**

**Oil Pressure  
Leaving Filter**

# New CCM Control Outputs

- VFD Coolant Flow (J11-1, Ground)
  - Used to prevent Dew from forming on Coldplate
- Vaporizer Heater (J11-2, Ground)
  - Used to add Supplemental Heat (when needed) to improve Oil Viscosity from Vaporizer
- Oil Reclaim (J8-3,4)
  - Used to control Oil Temperature leaving Vaporizer 12+/- 2F above Evaporator Refrigerant Temperature (Reclaim Delta T)

# New Control Algorithms

## Oil Heater Control

- Purpose
  - Maintain Oil Sump Temperature at a minimum of 140F and at least 53F above Evaporator Refrigerant Temperature up to 152F during shutdown
  - Maintain Oil Sump Temperature at a Minimum of 90F or 35F above Evaporator Refrigerant Temperature during Startup or Running
- Different from 19XR:
  - Oil Heater is allowed to operate during Startup/Run

# New Control Algorithms

## Vaporizer Heater Control (Normal Mode)

- Purpose
  - Add supplemental heat to the Vaporizer when:  
Condenser Refrigerant Temperature – Evaporator Refrigerant Temperature < 22 F, Or:  
Condenser Refrigerant Temperature – Evaporator Refrigerant Temperature < 22.5 F AND  
Compressor Motor RPM < 595
  - Vaporizer Heat turns OFF when:  
Condenser Refrigerant Temperature – Evaporator Refrigerant Temperature > 26 F, Or:  
Condenser Refrigerant Temperature – Evaporator Refrigerant Temperature > 23.5 F AND  
Compressor Motor RPM > 625

# New Control Algorithms

## Vaporizer Heater Control (Service Mode)

- Purpose

- Add supplemental heat to the Vaporizer when:

- Condenser Refrigerant Temperature < 80F and Compressor Motor RPM < 1660,

- Or:

- Condenser Refrigerant Temperature < Evaporator Refrigerant Temperature + 35F and Compressor Motor RPM < 1660,

- Or:

- Discharge Superheat < 0.15 (Condenser Refrigerant Temperature – Evaporator Refrigerant Temperature)

# New Control Algorithms

## Vaporizer Heater Control (Service Mode)

- Vaporizer Heat turns OFF when:

- Condenser Refrigerant Temperature > 82F and Condenser Refrigerant Temperature > Evaporator Refrigerant Temperature + 40F

- Or:

- Condenser Refrigerant Temperature > 85F

- Or

- Compressor Motor RPM > 1700 and Discharge Superheat > 0.15  
(Condenser Refrigerant Temperature – Evaporator Refrigerant Temperature) + 2F

# New Control Algorithms

## Oil Reclaim Output

- Purpose
  - Maintain Reclaim Delta (Oil Temperature leaving the Vaporizer - Evaporator Saturation Temperature) at  $12 \pm 2F$  after ramp loading is completed using a 4 – 20mA output.
  - Modulates Oil Reclaim Actuator/Valve between 25 and 100% open; 4 – 20mA (0.5K ohms) = 2 – 10vdc signal.
  - Oil Reclaim Output conditionally increases when Reclaim Delta T is  $> 14F$  and decreases when Oil Reclaim Delta T  $< 10F$

# 23XRV Oil/Lube System

Compressor  
Motor RPM

Vaporizer  
Temperature

Oil Heater

Oil Sump  
Pressure

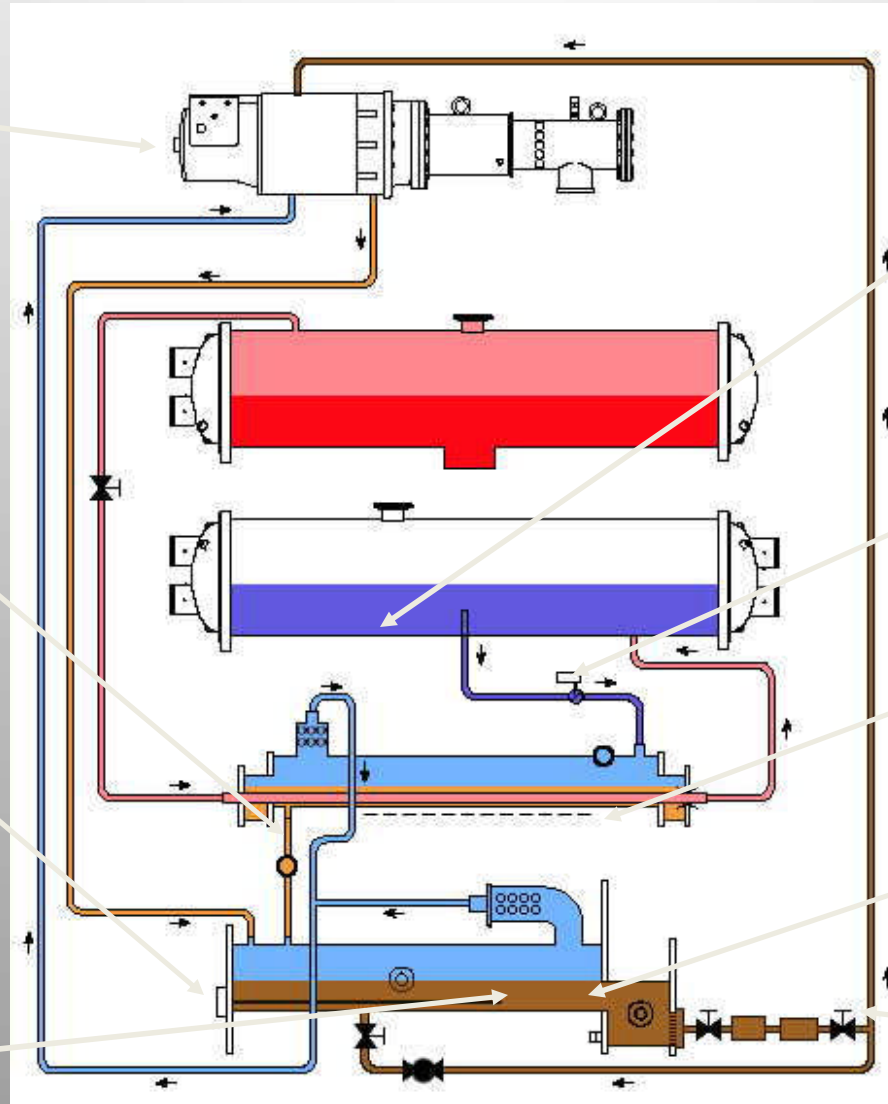

Evaporator  
Saturation  
Temperature

Oil Reclaim  
Output

Vaporizer  
Heater

Oil Sump  
Temperature

Oil Pressure  
Leaving Filter

# New Control Algorithms

## Compressor Minimum Speed Control

- Purpose
  - Maintain Compressor Speed above a predetermined minimum Value based on RPM vs. Viscosity.
    - As Viscosity decreases, the Compressor Minimum Speed increases as high as the COMP MAXIMUM SPEED configuration
    - As Viscosity increases, the Compressor Minimum Speed is allowed to decrease as low as the COMP MIN SPEED configuration
  - When compressor minimum speed is being controlled based on Viscosity, a “Compressor Minimum Speed Override” message is displayed

# Viscosity vs. Compressor RPM Relationship

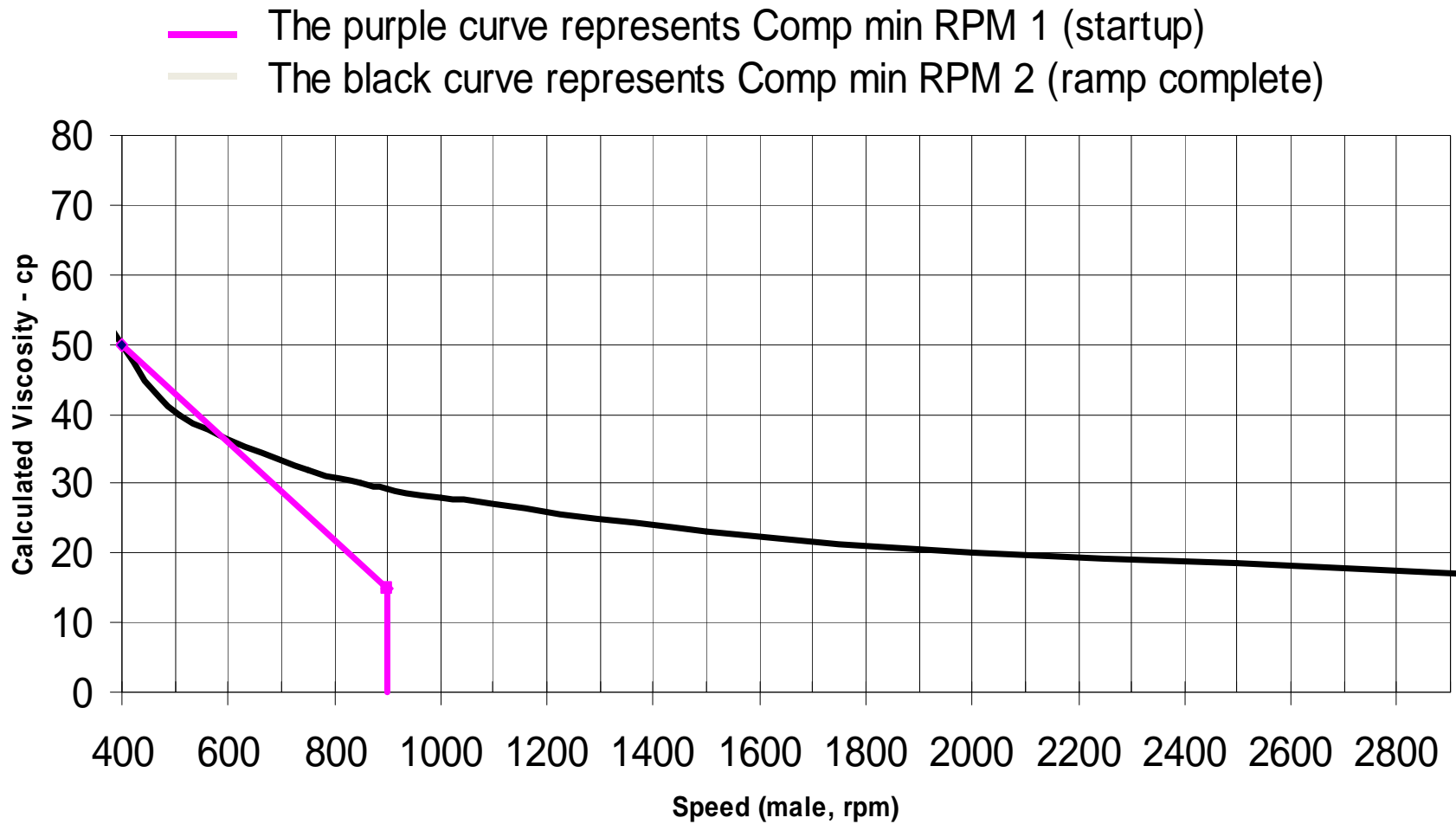

# New Control Algorithms

## VFD Dew Prevention (VFD Cooling) Control

- Purpose

- Maintain Coldplate Temperature above Dewpoint Temperature by de-energizing VFD Solenoid 0 – 100% every 5 sec based on the greater % calculated for 1 or 2 below:

- 1) Condenser Refrigerant Temperature is 1.5 - 3.5F above Coldplate Temperature

- 2) VFD Coldplate Temperature is 1 – 5F above Dewpoint Temperature

# New Control Algorithms

## VFD Dew Prevention (VFD Cooling) Control

- Output = 100% if:
  - Coldplate Temperature > 100F
  - or Coldplate Temperature > Dewpoint + 5F
  - or Condenser Refrigerant Temperature > 100F
  - or Condenser Refrigerant Temperature > Dewpoint + 3.5F
- Default Condition
  - VFD Cooling Solenoid is normally closed

# VFD\_CONF Screen

- Motor Nameplate Voltage
- Compressor 100% Speed
- Rated Line Voltage
- Rated Line Amps
- Rated Line Kilowatts
- Motor Rated Load KW
- Motor Rated Load Amps
- Motor Nameplate Amps
- Motor Nameplate RPM
- Motor Nameplate kW
- Inverter PWM frequency
  - (0 = 4Khz, 1 = 2Khz)
- Skip Frequency 1
- Skip Frequency 2
- Skip Frequency 3
- Skip Frequency Band
- Line Voltage % Imbalance
- Line Voltage Imbalance Time
- Line Current % Imbalance
- Line Current Imbalance Time
- Motor Current % Imbalance
- Motor Current Imbalance Time
- Increase Ramp Time
- Decrease Ramp Time
- Single Cycle Dropout

# Alarms and Troubleshooting

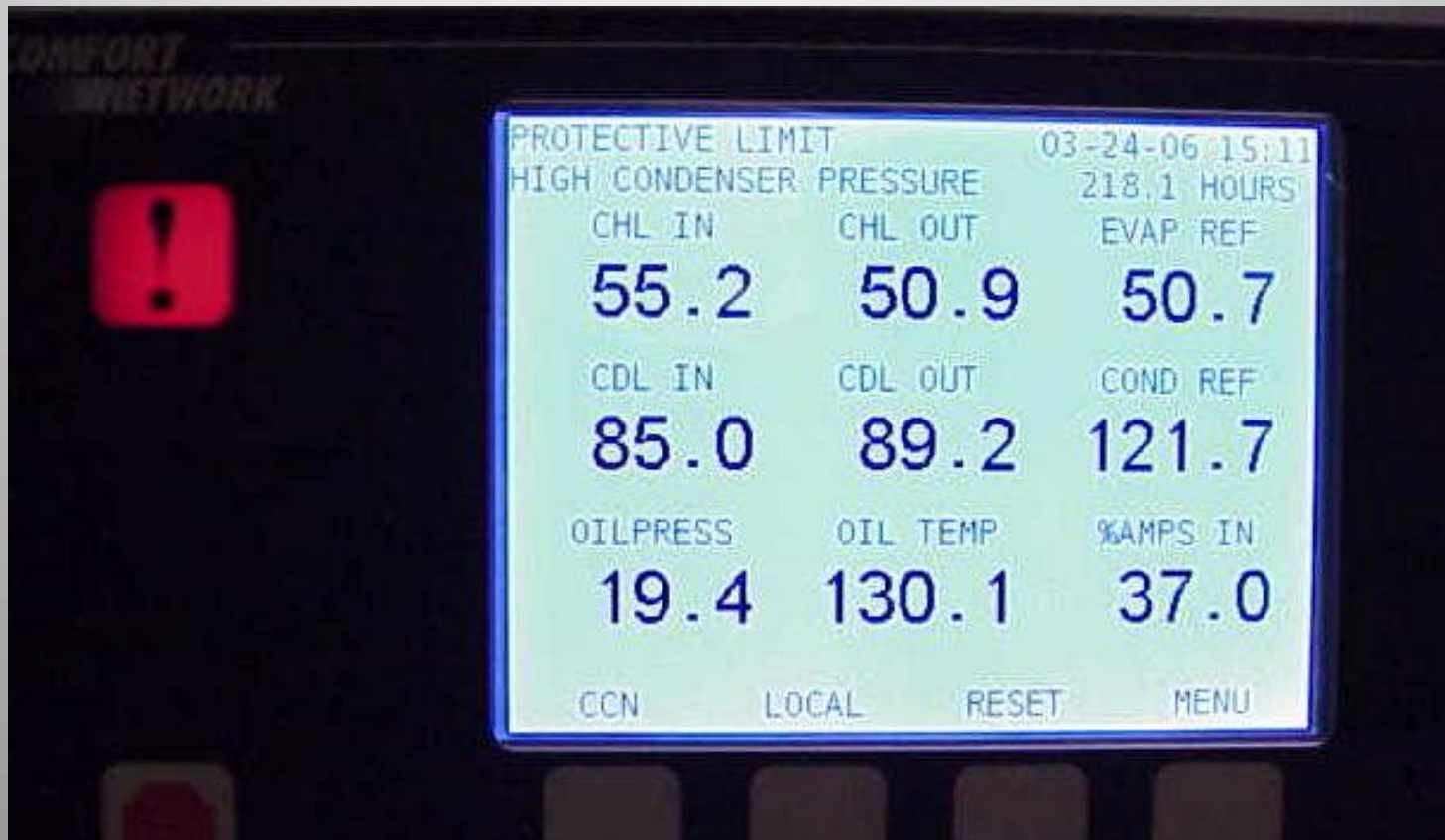

# Alarms and Troubleshooting

- Sources of Information
  - Default Screen
  - ICVC Alarm History
  - ICVC Alert History
    - Pre-Start & Normal Run with Overrides
  - ICVC VFD\_HIST
  - Protective Limits Table
  - Capacity Overrides Table
  - Parameter Index

# Troubleshooting Example

Default Screen  
Primary and  
Secondary Alarm  
Message

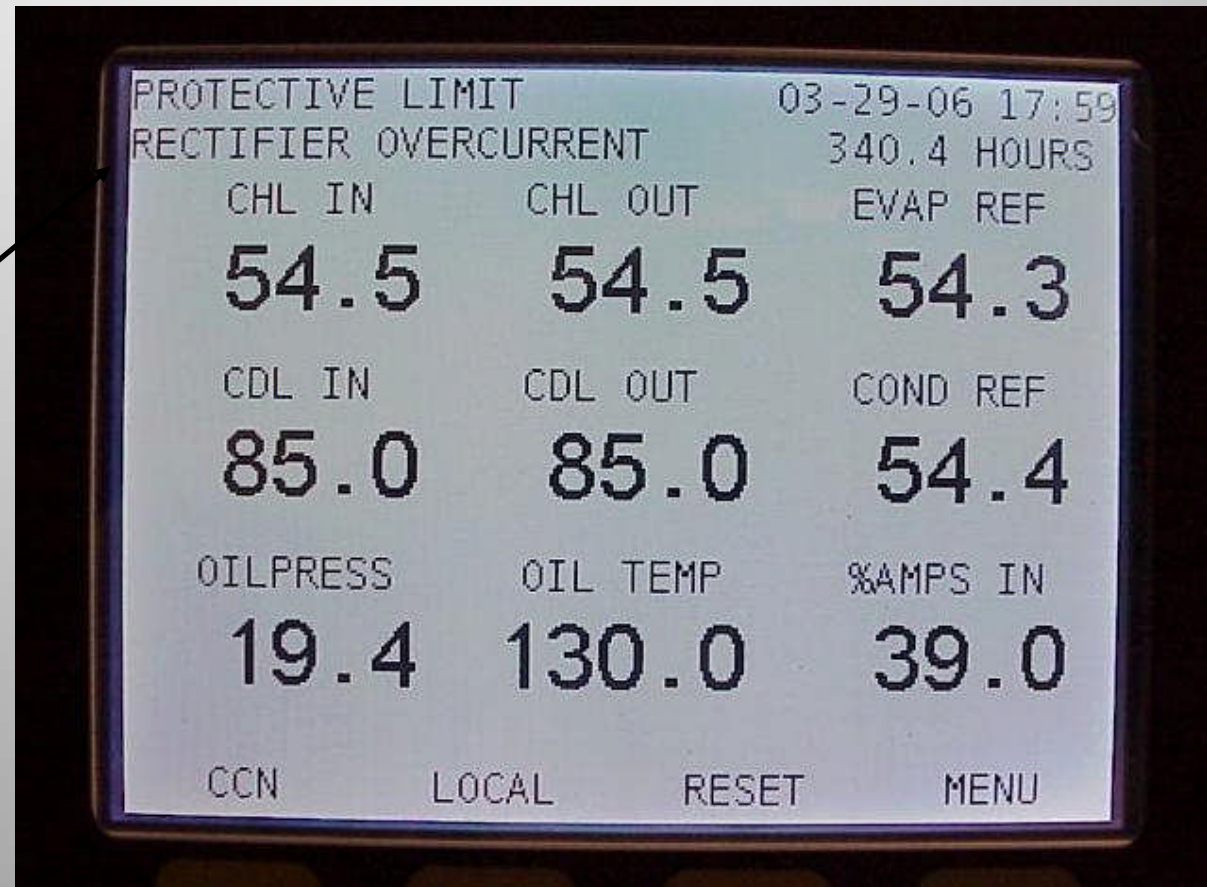

# Check Alarm History

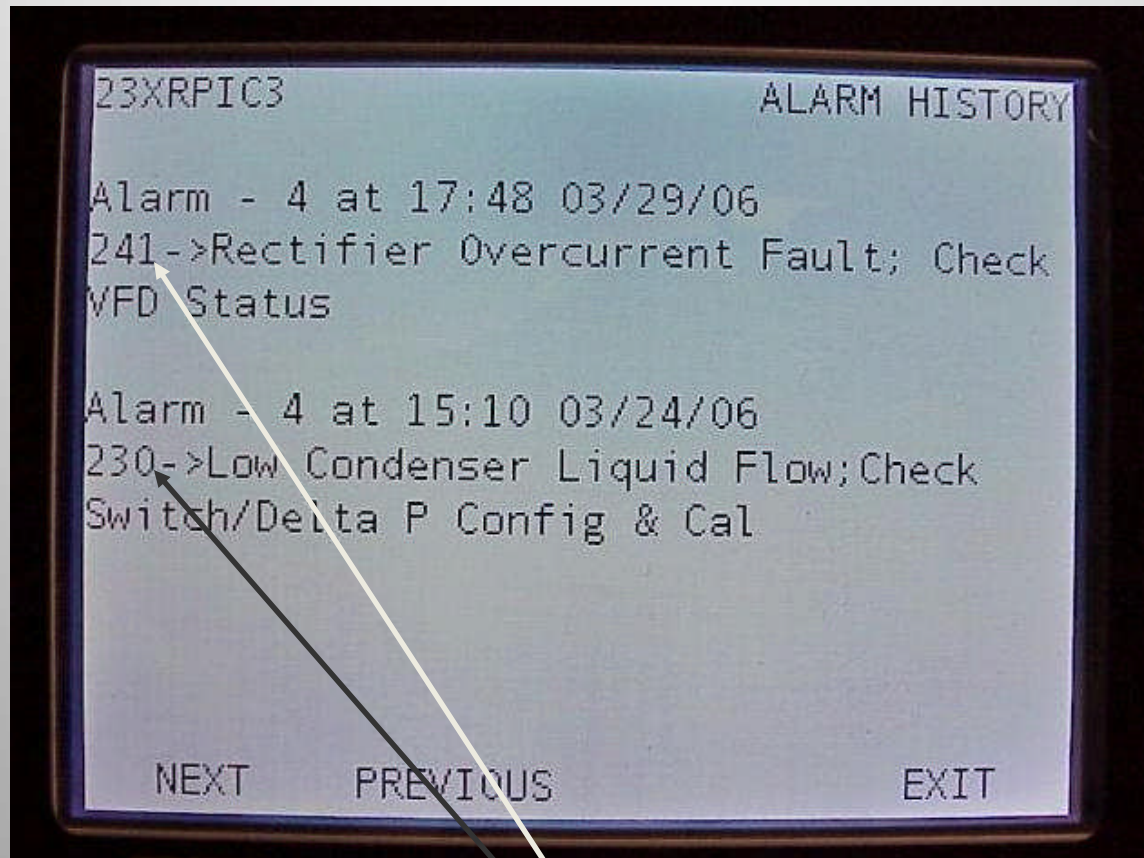

Note Alarm  
States

# ICVC Alarm State Table

| I. CHILLER PROTECTIVE LIMIT FAULTS |                  |                          |  |   |
|------------------------------------|------------------|--------------------------|--|---|
| STATE                              | PRIMARY MESSAGE  | SECONDARY MESSAGE        | ALARM MESSAGE PRIMARY CAUSE                                  | ADDITIONAL CAUSE/REMEDY   |
| 200                                | PROTECTIVE LIMIT | RECTIFIER POWER FAULT    | 200->Rectifier Power Fault: Check VFD Status                 | Check VFD FAULT CODE in VFD_HIST screen.<br>See VFD FAULT CODES in Table 16   |
| 201                                | PROTECTIVE LIMIT | INVERTER POWER FAULT     | 201->Inverter Power Fault: Check VFD Status                  | Check VFD FAULT CODE in VFD_HIST screen.<br>See VFD FAULT CODES in Table 16   |
| 202                                | PROTECTIVE LIMIT | MOTOR AMPS NOT SENSED    | 202->Motor Amps Not Sensed — Average Load Current [VALUE]    | Check main circuit breaker for trip.<br>Check VFD FAULT CODE in VFD_HIST screen.<br>See VFD FAULT CODES in Table 16<br>Check MOTOR RATED LOAD AMPS setting in VFD_CONF screen<br>See Table 5  |
| 203                                | FAILURE TO START | MOTOR ACCELERATION FAULT | 203->Motor Acceleration Fault — Average Load Current [VALUE] | Check starter for proper operation.<br>Reduce Condenser pressure if possible.<br>Check VFD FAULT CODE in VFD_HIST screen.<br>See VFD FAULT CODES in Table 16<br>Check MOTOR RATED LOAD AMPS setting in VFD_CONF screen<br>See Table 5 |
| 204                                | FAILURE TO STOP  | VFD SHUTDOWN FAULT       | 204->VFD Shutdown Fault: Check Inverter Power Unit           | Check VFD FAULT CODE in VFD_HIST screen.<br>See VFD FAULT CODES in Table 16<br>See Table 5  |
| 205                                | PROTECTIVE LIMIT | HIGH DC BUS VOLTAGE      | 205->High DC Bus Voltage: [VALUE] exceeded limit of [LIMIT]* | Check DC BUS VOLTAGE and VFD FAULT CODE in VFD_HIST screen.<br>See VFD FAULT CODES in Table 16.   |
| 241                                | PROTECTIVE LIMIT | RECTIFIER OVERCURRENT    | 241->Rectifier Overcurrent Fault: Check VFD Status           | Check <b>LINE</b> CURRENT and VFD FAULT CODE in VFD_HIST screen.<br>See VFD FAULT CODES in Table 16   |

# Check VFD\_HIST Screen

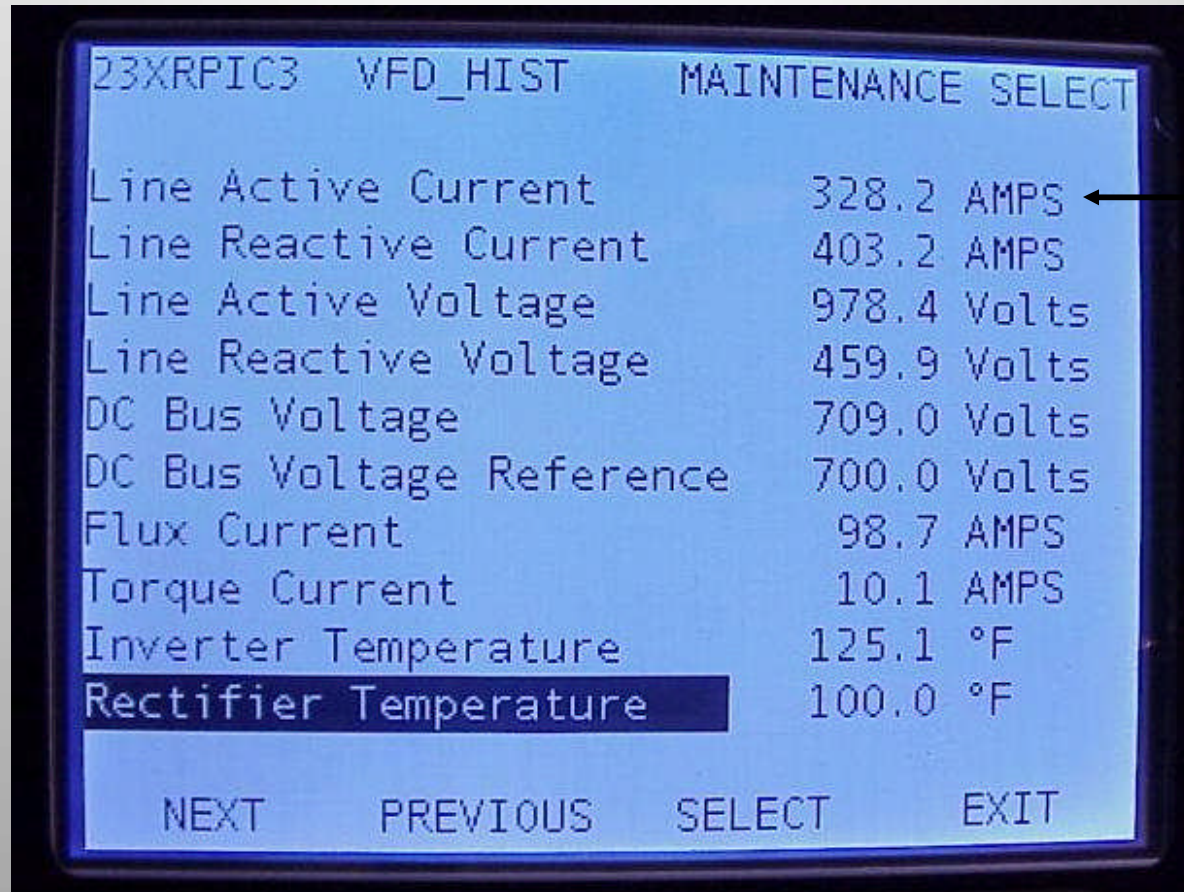

23XRPIC3 VFD\_HIST MAINTENANCE SELECT

|                          |             |
|--------------------------|-------------|
| Line Active Current      | 328.2 AMPS  |
| Line Reactive Current    | 403.2 AMPS  |
| Line Active Voltage      | 978.4 Volts |
| Line Reactive Voltage    | 459.9 Volts |
| DC Bus Voltage           | 709.0 Volts |
| DC Bus Voltage Reference | 700.0 Volts |
| Flux Current             | 98.7 AMPS   |
| Torque Current           | 10.1 AMPS   |
| Inverter Temperature     | 125.1 °F    |
| Rectifier Temperature    | 100.0 °F    |

NEXT PREVIOUS SELECT EXIT

From VFD\_CONF: RATED LINE AMPS = 200 A

# Check for Chiller Fault State and VFD Fault Code

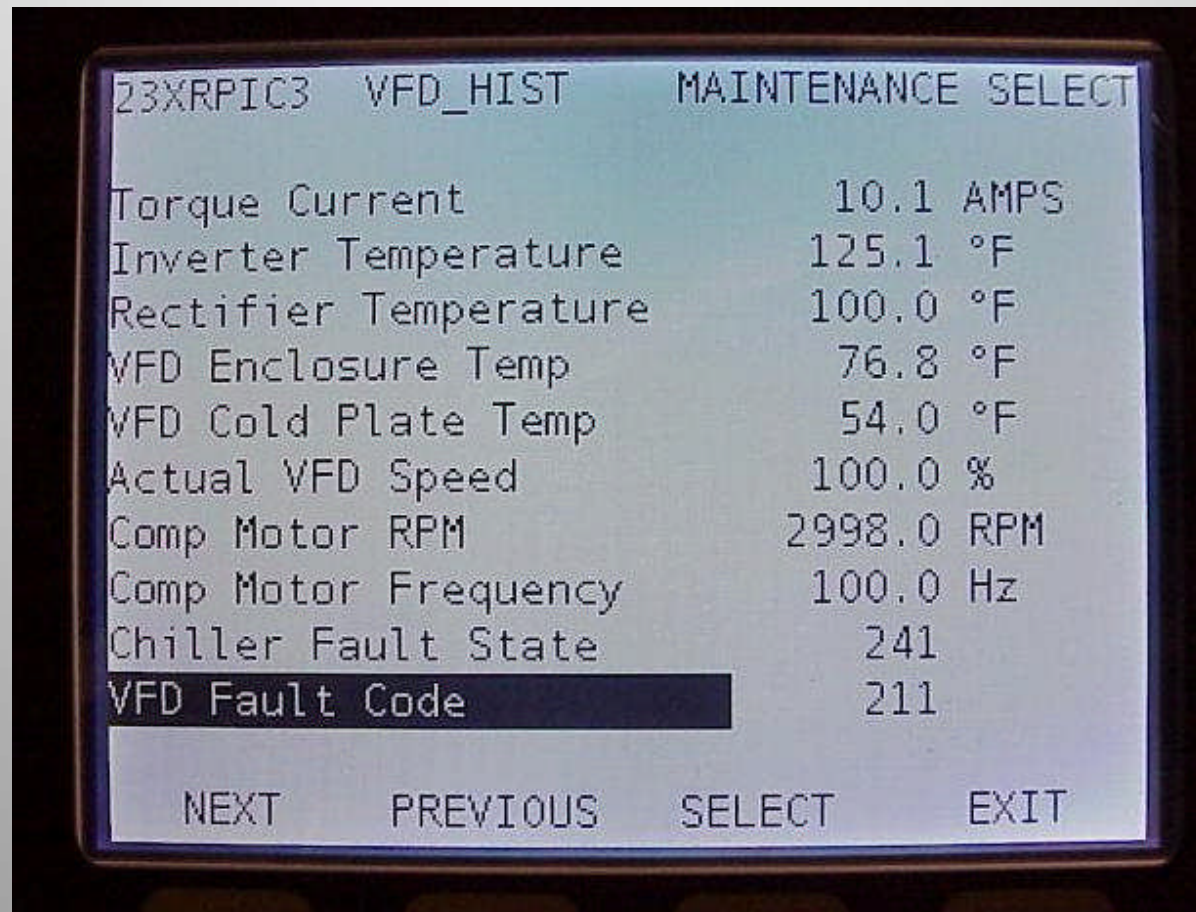

The image shows a control panel display with a menu titled '23XRPIC3 VFD\_HIST MAINTENANCE SELECT'. The display lists various operational parameters and their values. The 'VFD Fault Code' is highlighted with a dark background.

| Parameter             | Value  | Unit |
|-----------------------|--------|------|
| Torque Current        | 10.1   | AMPS |
| Inverter Temperature  | 125.1  | °F   |
| Rectifier Temperature | 100.0  | °F   |
| VFD Enclosure Temp    | 76.8   | °F   |
| VFD Cold Plate Temp   | 54.0   | °F   |
| Actual VFD Speed      | 100.0  | %    |
| Comp Motor RPM        | 2998.0 | RPM  |
| Comp Motor Frequency  | 100.0  | Hz   |
| Chiller Fault State   | 241    |      |
| VFD Fault Code        | 211    |      |

Navigation options at the bottom: NEXT, PREVIOUS, SELECT, EXIT

# VFD Fault Code Table

Table 16 – Fault Descriptions and Corrective Actions

| Fault Code | Fault              | Type | Description  | Action  | Fault State |
|------------|--------------------|------|--|---|-------------|
| 2          | Auxiliary Input    | 1    | Input is open.   | Check remote wiring.  | 206         |
| 3          | Power Loss         | 1, 3 | DC bus voltage remained below 85% of nominal for longer than Power Loss Time (185).<br>Enable/disable with Fault Config 1 (238).                                 | Monitor the incoming AC line for low voltage or line power interruption.  | 149<br>215  |
| 4          | UnderVoltage       | 1, 3 | DC bus voltage fell below the minimum value of 407V DC at 400/480V input or 204V DC at 200/240V input.<br>Enable/disable with Fault Config 1(238).               | Monitor the incoming AC line for low voltage or power interruption.   | 149<br>215  |
| 5          | OverVoltage        | 1    | DC bus voltage exceeded maximum value.   | Monitor the AC line for high line voltage or transient conditions. Bus overvoltage can also be caused by motor regeneration. Extend the decel time or install dynamic brake option. | 150<br>205  |
| 7          | Motor Overload     | 1, 3 | Internal electronic overload is set to trip when the motor current equals 135% of Motor NP FLA(42) for 1.5 seconds.<br>Enable/disable with Fault Config 1 (238). | An excessive motor load exists. Reduce load so drive output current does not exceed the current set by Motor NP FLA (42).   | 217         |
| 8          | Invtr Base Temp    | 1    | Base temperature exceeded limit.   | Check for proper temperature and flow rate of coolant.  | 219         |
| 211        | Rectifier Over Cur | 4    | Rectifier overcurrent  | 1. Verify proper motor data is entered.   | 241         |
| 212        | R, S, T            |      |  | 2. Reduce current limit.  |             |
| 213        |                    |      |  |   |             |

VFD Fault Code  
from VFD\_HIST  
screen

Corresponding ICVC  
Fault State

# Protective Limits Table

| <b>Table 5 - Protective Limits and Control Settings</b> |                  |  |  |
|---|------------------|--|--|
| <b>Monitored Parameter</b>                              | <b>State</b>     | <b>Limit</b>   | <b>Comments</b>  |
| Temperature Sensors Out of Range                        | 260-271, 140,141 | -40 deg F > Temperature > 245 deg F for 3 seconds  | Preset Alarm. See Temperature vs. Resistance/Voltage Drop in Table 13A and 13B |
| Pressure Transducers Out of Range                       | 262-272          | .06 > Voltage Ratio > .98 for 3 seconds  | Preset Alarm Voltage Ratio = Input Voltage/Voltage Reference (5 Volts)         |
| High Compressor Discharge Temperature                   | 231              | COMP DISCHARGE TEMP > 180 deg F (82 deg C)   | Preset Alarm, Configure DISCH TEMP ALERT in SETUP1 screen                      |
|   | 162              | COMP DISCHARGE TEMP > COMP DISCHARGE ALERT   | Configure COMP DISCH ALERT in SETUP1 screen                                    |
|   | 103              | COMP DISCHARGE TEMP > COMP DISCHARGE ALERT - 10 deg F (5.6 deg C)                        | Prestart Alert, Configure COMP DISCHARGE ALERT in SETUP1 screen                |
| High Motor Temperature                                  | 233              | COMP MOTOR WINDING TEMP > 244 deg F (118 deg C) or < -5 deg F (-21 deg C) - Open Circuit | Preset Alarm   |
|   | 102              | COMP MOTOR WINDING TEMP > COMP MOTOR TEMP OVERRIDE - 10 deg F (5.6 deg C)                | Prestart Alert, Configure COMP MOTOR TEMP OVERRIDE in SETUP1 screen            |

## Applicable ICVC Parameter Names and Limits Referenced

# Check Alert History

```
23XRPIC3                                ALERT HISTORY

Alert - 4 at 14:56 03/24/06
161->Condenser Approach 11.3 ^F
exceeded limit of 6.0 ^F.

Alert - 4 at 14:54 03/24/06
106->Condenser Pressure 134.5 PSI
exceeded limit of 120.0 PSI.

Alert - 4 at 11:22 03/23/06
148->Control Power-Loss When Running

NEXT          PREVIOUS          EXIT
```

Note Alert  
State

# Chiller Alerts Table

| J. CHILLER ALERTS |                 |                           |  |   |
|-------------------|-----------------|---------------------------|--|---|
| STATE             | PRIMARY MESSAGE | SECONDARY MESSAGE         | ALARM MESSAGE PRIMARY CAUSE                                | ADDITIONAL CAUSE/REMEDY   |
| 140               | SENSOR ALERT    | LEAVING COND LIQUID TEMP  | 140->Sensor Fault: Check Leaving Cond Liquid Sensor        | Temperature sensor reading out of range.<br>Check LEAVING COND LIQUID TEMP sensor resistance or voltage drop at CCM.<br>Check for grounded sensor leads.<br>Check for proper wiring.<br>See Table 5   |
| 141               | SENSOR ALERT    | ENTERING COND LIQUID TEMP | 141->Sensor Fault: Check Entering Cond Liquid Sensor       | Temperature sensor reading out of range.<br>Check ENTERING COND LIQUID TEMP sensor resistance or voltage drop at CCM.<br>Check for grounded sensor leads.<br>Check for proper wiring.<br>See Table 5  |
| 161               | SENSOR ALERT    | CONDENSER APPROACH        | 161->Condenser Approach [VALUE] Exceeded Limit of [LIMIT]* | Check COND APPROACH ALERT setting in SETUP1 screen.<br>Check Condenser Liquid flow.<br>See Table 5<br>Check CONDENSER PRESSURE and LEAVING COND LIQUID temperature sensor resistances or voltage drops.<br>Check for proper CONDENSER PRESSURE and LEAVING COND LIQUID temperature sensor wiring.<br>Check condenser shell temperature against condenser pressure measured with refrigerant gage for evidence of non-condensables in refrigerant charge.<br>Check for condenser division plate bypass.<br>Check for fouled condenser tubes. |

# ICVC Alert with Override Table

| G. NORMAL RUN WITH OVERRIDES |                      |                         |  |  |
|------------------------------|----------------------|-------------------------|--|--|
| STATE                        | PRIMARY MESSAGE      | SECONDARY MESSAGE       | ALARM MESSAGE PRIMARY CAUSE                                      | ADDITIONAL CAUSE/REMEDY  |
| 120                          | RUN CAPACITY LIMITED | HIGH CONDENSER PRESSURE | 120->Condenser Pressure [VALUE] exceeded limit of [LIMIT]*.      | Check for high condenser liquid temperatures.<br>Check COND PRESS OVERRIDE setting in SETUP1.  |
| 121                          | RUN CAPACITY LIMITED | HIGH MOTOR TEMPERATURE  | 121->Comp Motor Winding Temp [VALUE] exceeded limit of [LIMIT]*. | Check motor cooling lines.<br>Check for closed valves.<br>Check COMP MOTOR TEMP OVERRIDE setting in SETUP1.                                |
| 122                          | RUN CAPACITY LIMITED | LOW EVAP REFRIG TEMP    | 122->Evaporator Refrig Temp [VALUE] exceeded limit of [LIMIT]*.  | Check REFRIG TEMP OVERRIDE DELTA T setting in SETUP1 screen.<br>Check refrigerant charge.<br>Check for low entering cooler temperatures.   |
| 123                          | RUN CAPACITY LIMITED | HIGH RECTIFIER TEMP     | 123->Rectifier Temperature [VALUE] exceeded limit of [LIMIT]     | Check VFD refrigerant isolation valves.<br>Check VFD refrigerant cooling solenoid valve.<br>Check RECTIFIER TEMP OVERRIDE in SETUP1 screen |
| 124                          | RUN CAPACITY LIMITED | MANUAL SPEED CONTROL    |  | TARGET VFD SPEED in COMPRESS screen is forced to a fixed value   |
| 125                          | RUN CAPACITY LIMITED | HIGH INVERTER TEMP      | 125->Inverter Temperature [VALUE] exceeded limit of [LIMIT]      | Check VFD refrigerant isolation valves.<br>Check VFD refrigerant cooling solenoid valve.<br>Check INVERTER TEMP OVERRIDE in SETUP1 screen  |

# Capacity Overrides Table

| Table 6 - Capacity Overrides Table                   |                            |                       |                                    |   |  |
|--|----------------------------|-----------------------|------------------------------------|---|--|
| Override Capacity Control                            | View/Modify on ICVC Screen | First Stage Set Point |                                    | Second Stage Set Point  | Second Stage Override Termination                              |
|  |                            | Default Value         | Configurable Range                 | Value   | Value  |
| High Condenser Pressure (COND PRESS OVERRIDE)        | SETUP1                     | 145 PSIG(1000 kPa)    | 145 to 166 PSIG (1000 to 1145 kPa) | CONDENSER PRESSURE > COND PRESS OVERRIDE + 2.4 PSIG(16.5 kPa)<br><b>OR</b><br>CONDENSER PRESSURE > 163 PSIG(1124 kPa)                                       | CONDENSER PRESSURE < CONDENSER PRESS OVERRIDE - 1 PSI(6.9 kPa) |
| Low Evaporator Temperature (REFRIG OVERRIDE DELTA T) | SETUP1                     | 3 deg F(1.7 deg C)    | 2 to 5 deg F (1.1 to 2.8 deg C)    | EVAPORATOR REFRIG TEMP < EVAP REF OVERRIDE TEMP - 1 deg F(6 deg C)<br><b>NOTE:</b> EVAP REF OVERRIDE TEMP = EVAP REFRIG TRIPPOINT + REFRIG OVERRIDE DELTA T | EVAP REFRIG TEMP > EVAP REF OVERRIDE TEMP + 2 deg F(1.1 deg C) |

First Stage Threshold – VFD Speed Increase Inhibited  
 Second Stage Threshold – VFD Speed Decrease Forced  
 (except for “Comp Min Speed in Effect”)  
 “Third Stage” Threshold – Shutdown on Alarm

# Alphabetical ICVC Parameter Index

| <b>Appendix A: ICVC Parameter Index</b>       |                     |                          |                    |                     |
|---|---------------------|--------------------------|--------------------|---------------------|
| <b>Parameter</b>                              | <b>MENU SoftKey</b> | <b>Table</b>             | <b>Screen Name</b> | <b>Configurable</b> |
| 1 <sup>st</sup> Current Alarm State           | SERVICE             | CONTROL ALGORITHM STATUS | CUR_ALRM           |                     |
| 20mA Demand Limit Opt(Demand Limit & KW Ramp) | SERVICE             | EQUIPMENT SERVICE        | RAMP_DEM           | X                   |
| 2 <sup>nd</sup> Current Alarm State           | SERVICE             | CONTROL ALGORITHM STATUS | CUR_ALRM           |                     |
| 3 <sup>rd</sup> Current Alarm State           | SERVICE             | CONTROL ALGORITHM STATUS | CUR_ALRM           |                     |
| 4 <sup>th</sup> Current Alarm State           | SERVICE             | CONTROL ALGORITHM STATUS | CUR_ALRM           |                     |
| 5 <sup>th</sup> Current Alarm State           | SERVICE             | CONTROL ALGORITHM STATUS | CUR_ALRM           |                     |
| Active Delta P                                | STATUS              |                          | HEAT_EX            |                     |
| Active Delta T                                | STATUS              |                          | HEAT_EX            |                     |
| Active Demand Limit                           | STATUS              |                          | MAINSTAT           | X                   |
| Actual VFD Speed                              | SERVICE             | CONTROL ALGORITHM STATUS | CAPACITY           |                     |
| Actual VFD Speed                              | STATUS              |                          | COMPRESS           |                     |
| Actual VFD Speed                              | STATUS              |                          | POWER              |                     |
| Actual VFD Speed(At Last Fault)               | SERVICE             | CONTROL ALGORITHM STATUS | VFD_HIST           |                     |
| Address #                                     | SERVICE             |                          | ICVC CONFIGURATION | X                   |

**ICVC Parameters  
from Tables in  
O&M Manual**



**Key Sequence to find ICVC  
Parameter**

**“X” if  
Configurable**

# LiquiFlo-1 and LiquiFlo-2 Parts

Contact RCD for all pricing and lead-time

- LF-1 and LF-2 replacement parts in and out of warranty
- Entire VFDs for 19XL and 19XR field retrofits can be purchased directly from Rockwell.

# LiquiFlo-1 and LiquiFlo-2 Parts

## RCD Stocks the following LF1 Parts

- RX-41LR4060: 414 Amp Power Module
- RX-50LR4060: 500 Amp Power Module
- RX-64LR4060: 643 Amp Power Module
- 179116: Regulator Card - Used on all Liquiflo-1 Drives
- 2SI3000: Remote Meter Interface Card  
Used on all Liquiflo-1 drives
- 179170: 414 Amp Power Module Control Card
- 179134: 500 Amp Power Module Adapter Card
- 179067: 643 Amp Power Module Adapter Card
- 179069: Bus Control Card - Used on 500 and 643 Amp Drives
- RC-SNUBBER-C: Snubber Resistor Kit

# LiquiFlo-1 and LiquiFlo-2 Parts

- RCD stocks the following LF2 Parts
  - RX-LF200460AAR: 460 Amp Power Module
  - RX-LF200608CCR: 608 Amp Power Module

# LiquiFlo-1 and LiquiFlo-2

## Parts

### Power Module and Control Card Core Credits

- Work through RCD and get an RMA to begin return process
  
- Reliance will determine if Power Module Credit will be issued
  - Warranty will be denied if there is evidence of corrosion inside of the power module
    - Protect failed parts during storage and shipping
  
  - If Reliance issues credit to RCD, then RCD will issue credit to the Carrier Warranty Manager.

# LiquiFlo-1 and LiquiFlo-2 Parts

## Power Module and Control Card Credits

- Local Carrier Office is responsible for shipping failed Power Module or Control Card to Reliance in the U.S.
  - Local Office must pay duties and freight
- Authorized Return Material paperwork (issued by RCD) must accompany the failed Power Module or Control Card. Mark container with WARP number.