

### LIQUID COOLED SOLID STATE STARTER

MODELS SSS 7L, 14L, 26L, 33L  
&  
MODELS SSS 7L-A, 14L-A, 26L-A, 26LK-A, 33L-A, 33LK-A  
(STYLE A)

#### NOTE

Unless noted otherwise, information in this instruction is applicable to all style starters of the same size.

Ex: 26L, 26LA AND 26LK-A

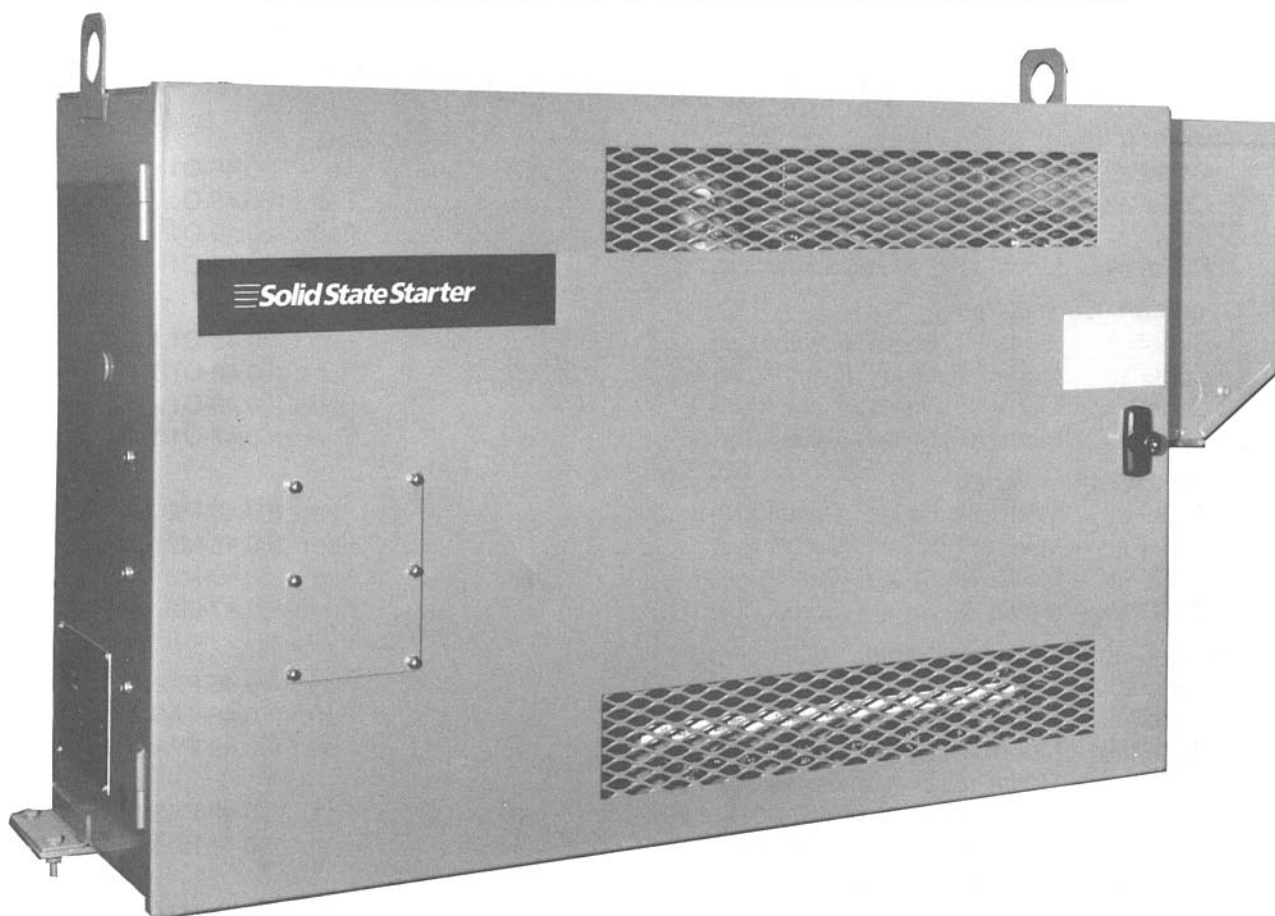

SECTION  
1

SECTION  
2

SECTION  
3

SECTION  
4

SECTION  
5

SECTION  
6

SECTION  
7

SECTION  
8

## TABLE OF CONTENTS

<b>SECTION 1</b>	
INTRODUCTION .....	3
<b>SECTION 2</b>	
THEORY OF OPERATION .....	3
<b>SECTION 3</b>	
SYSTEM ARCHITECTURE .....	6
<b>SECTION 4</b>	
COMPONENT DESCRIPTIONS .....	6
Logic Board .....	6
Trigger Board .....	13
<b>SECTION 5</b>	
SCR HEATSINK ASSEMBLY .....	17
Cooling Loop .....	19
Fill Instructions .....	19
Drain Instructions .....	20
<b>SECTION 6</b>	
SYSTEM CALIBRATION .....	20
<b>SECTION 7</b>	
START-UP CHECKLIST .....	20
<b>SECTION 8</b>	
TROUBLESHOOTING .....	21

## REFERENCE INSTRUCTIONS

### Operation (Unit)

CodePak – Model YT, Style E (Centrifugal) .....	Form 160.46-O1
CodePak – Model YT, Style F (Centrifugal) .....	Form 160.48-O1
CodePak – Model YK, Style A (Centrifugal) .....	Form 160.49-O1
CodePak – Model YS, Style A (Screw Chiller) .....	Form 160.47-O1

### Operation (Control Panel)

CodePak – Model YT, Style E (Centrifugal) .....	Form 160.46-O1.1
CodePak – Model YT, Style F (Centrifugal) .....	Form 160.48-O1.1
CodePak – Model YK, Style A (Centrifugal) .....	Form 160.49-O1
CodePak – Model YS, Style A (Screw Chiller) .....	Form 160.47-O1.1

### Service (Control Panel)

CodePak – Model YT, Style E (Centrifugal) .....	Form 160.46-M2
CodePak – Model YT, Style F (Centrifugal) .....	Form 160.48-M2
CodePak – Model YK, Style A (Centrifugal) .....	Form 160.49-M2
CodePak – Model YS, Style A (Screw Chiller) .....	Form 160.47-M2

### Wiring Diagram (Control Panel)

CodePak – Model YT, Style E (Centrifugal) .....	Form 160.46-PA2.1
CodePak – Model YT, Style F (Centrifugal) .....	Form 160.48-PA6
CodePak – Model YK, Style A (Centrifugal) .....	Form 160.49-PW4
CodePak – Model YS, Style A (Screw Chiller)	
Control Panel #371-01112-001 .....	Form 160.47-PA2.1
Control Panel #371-01200-003 .....	Form 160.47-PA6

### Wiring Diagram (Solid State Starter)

CodePak – Model YT, Style E (Centrifugal) .....	Form 160.46-PA2.5
CodePak – Model YT, Style F (Centrifugal) .....	Form 160.48-PA8
CodePak – Model YK, Style A (Centrifugal) .....	Form 160.49-PW6
CodePak – Model YS, Style A (Screw Chiller)	
Control Panel #371-01112-001 .....	Form 160.47-PA2.5
Control Panel #371-01200-003 .....	Form 160.47-PA8

SECTION  
1SECTION  
2

FIG.1 – SOLID STATE STARTER - FRONT VIEW - EXTERIOR

## SECTION 1 INTRODUCTION

This instruction is a description of the operation, start-up and troubleshooting of the YORK Liquid Cooled Solid State Starter. It should be read thoroughly before servicing this product. Due to the integration of the Solid State

Starter with the YORK MicroComputer Control Center an understanding of the Control Center is necessary. Therefore, this document should be used with referenced instructions on Page 2.

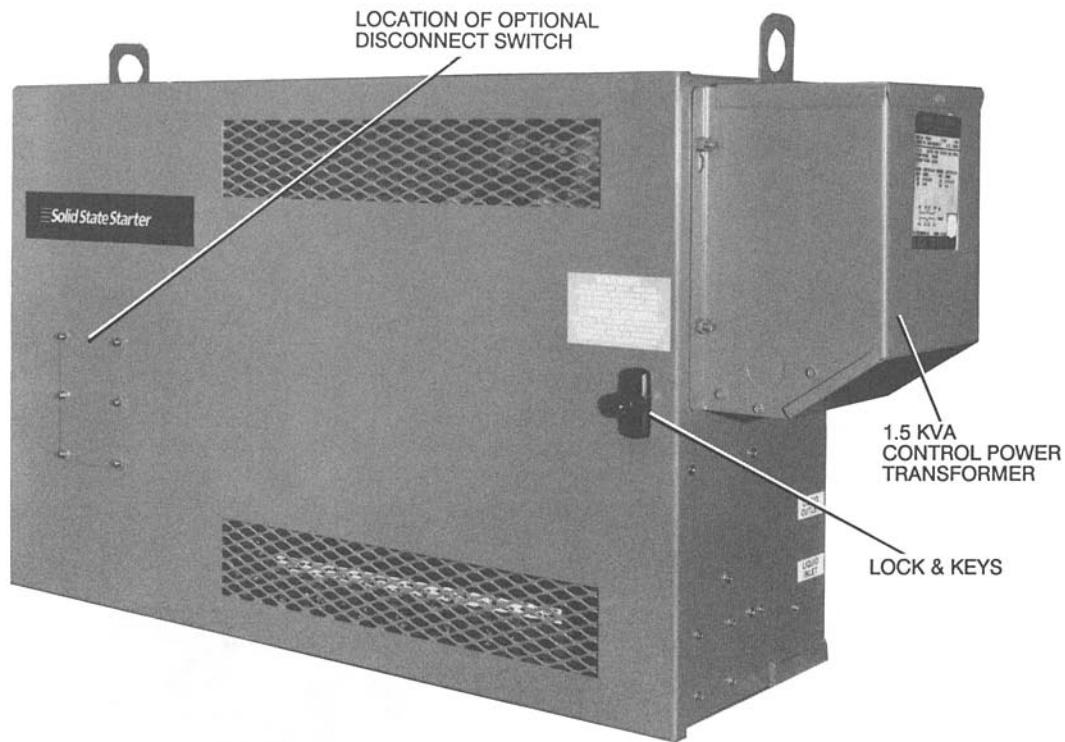
## SECTION 2 THEORY OF OPERATION

### OVERVIEW (Refer to FIG. 2, 3 and 4)

The Liquid Cooled Solid State Starter provides a soft continuous - current start for the compressor motor. During the starting sequence the motor current is limited to 45% of Delta Locked Rotor Amps. This is accomplished by turning-on silicon controlled rectifiers (SCR'S) in a "phase-back" technique during motor acceleration. A **Trigger Board** provides the firing (Turn-ON) pulses to the SCR's based upon a control voltage (VCON or Delay angle) provided by the **Logic Board** located in the Micro-Computer Control Center. This control voltage determines the magnitude of the "phase-back" delay.

The SCR assemblies are cooled by pump driven water circulating in a closed loop through the SCR heatsinks and a heat exchanger. As the water passes through the heat exchanger it is cooled by system condenser water that is

also flowing through the heat exchanger. The design of the heat exchanger prevents the closed loop cooling water from mixing with the condenser water. The **Trigger Board** constantly monitors the temperature of the SCR assemblies. If the temperature of any assembly exceeds 100°C, the **Trigger Board** initiates a "High Temp (100°C)" safety shutdown. Further, anytime the temperature exceeds 110°F, the system will be prevented from starting and the water pump will be operated.

Proper starter operation requires that all phases of the AC powerline voltage are present in the correct phase rotation and the SCR firing pulses remain in correct synchronization with the AC powerline. If these requirements are not satisfied, the **Trigger Board** initiates a "Phase Rotation/Loss" or "Out of Lock (OOL)" system shutdown.

Compressor motor protection circuits are provided on the **Logic Board**. A "power fault" circuit provides protection

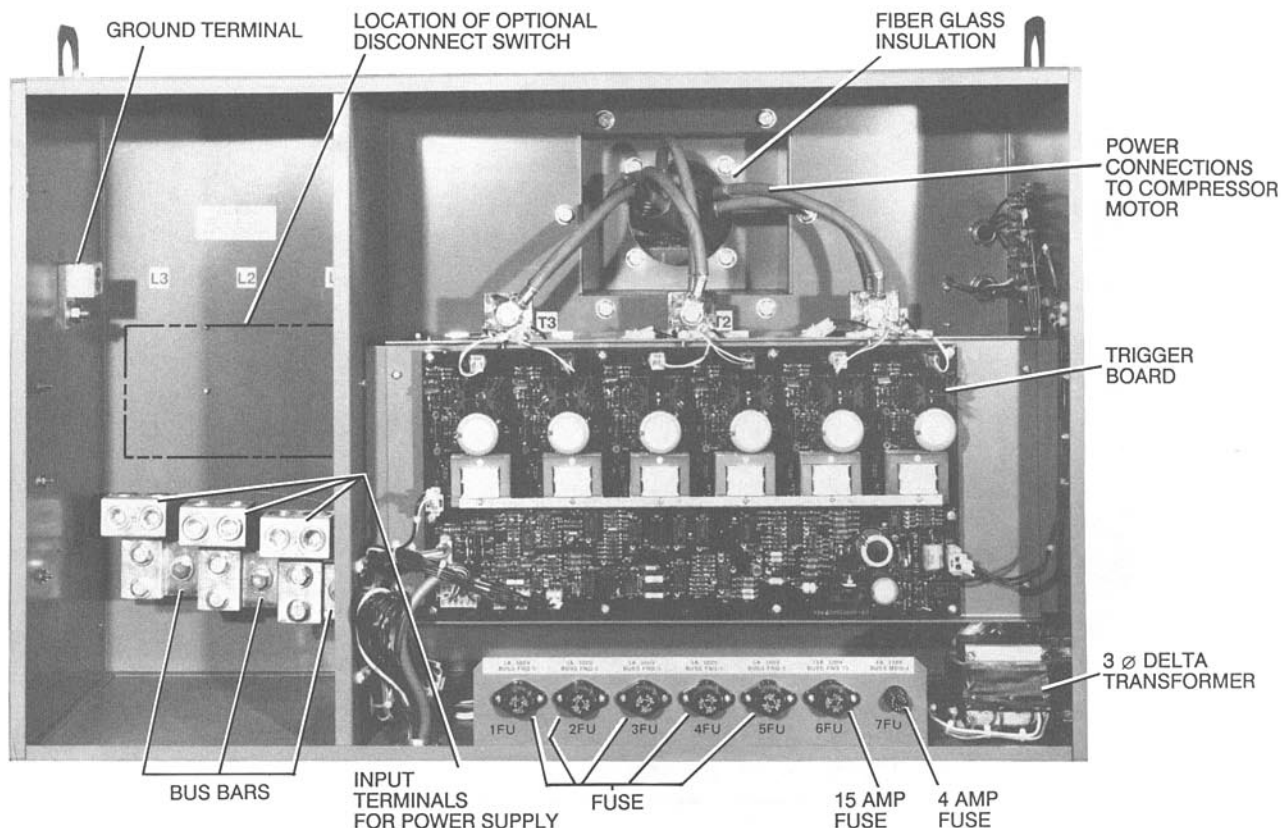

FIG. 2 – SOLID STATE STARTER - INTERIOR - CONNECTION SECTION - FUSES AND TRIGGER BOARD

from a rapid power line current interruptions and transient switching. "Overload" and "fault current" circuits protect the motor from continuous or instantaneous high current levels.

A "half phase" circuit (Rev. "D" and later Logic Boards) shuts down the chiller if 1/2 cycle of one phase of current is not conducted to the compressor motor.

Anytime the starter initiates a system shutdown, the **Logic Board** interrupts the "motor controller" circuit in the MicroComputer Control Center. The Control Center executes the system shutdown and **DAY XX:XXAM/PM MOTOR CONTROLLER-EXT RESET** or **DAY XX:XXAM/PM POWER FAULT - AUTOSTART** is displayed on the control center display, the actual message displayed is determined by the shutdown. Refer to "Section 4". Simultaneously, the appropriate Logic Board LED illuminates to annunciate the reason for shutdown. Some starter initiated shutdowns allow the chiller to restart after the cause clears; others require a manual reset on the starter logic board to permit a restart as follows:

- Overload – Manual Reset
- High Temp –
  - > 100°C – Manual reset
  - > 110°F (Start Inhibit) – Auto-Restart after condition clears
- Fault Current – Manual Reset

- Power Fault – Auto-Restart after condition clears
- Phase Rotation/Loss – Auto-Restart after condition clears
- Out Of Lock (OOL) – Auto-Restart after condition clears
- Half Phase – Auto-Restart after condition clears (Rev "D" Logic Boards and later)

Three phase AC power line voltage and three-phase compressor motor current are displayed on the MicroComputer Control Center display. These values are multiplexed out of the logic board to the MicroComputer Control Center Micro Board. The microprocessor compares the actual line voltage values with a minimum required threshold. If any phase decreases below this threshold the Micro Board initiates a system shutdown and prevents starting. **DAY XX:XXAM/PM LOW LINE VOLTAGE** is displayed on the Control Center display. The Micro Board software also checks the three phase motor current for unbalance conditions. If the motor current unbalance exceeds the acceptable amount, the Micro Board initiates a system shutdown. **DAY XX:XXAM/PM MTR PHASE CURRENT UNBALANCE** is displayed on the Control Center display. Refer to MicroComputer Control Center Operation Instruction Form referenced on Page 2.

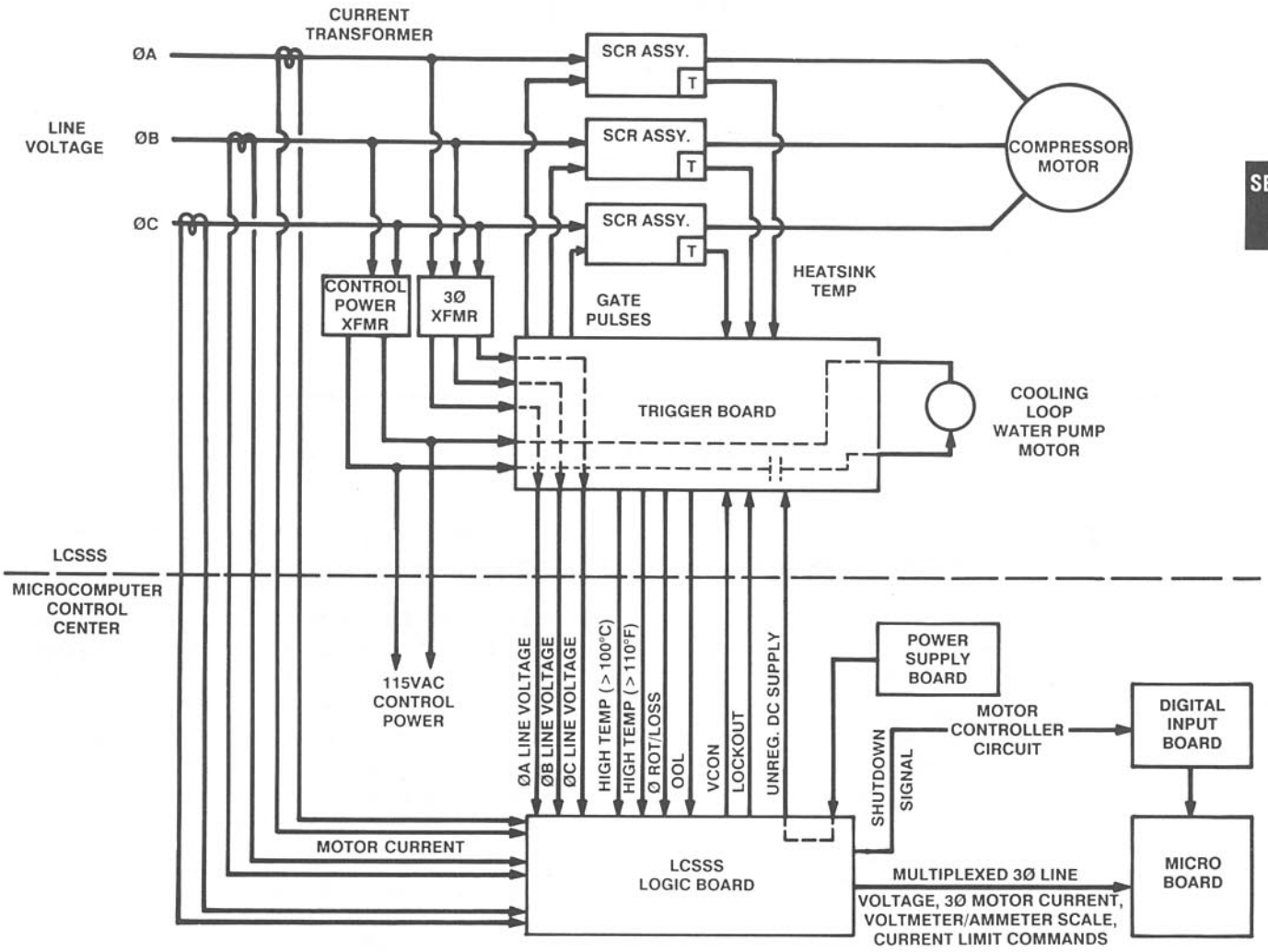

FIG. 3 – LIQUID COOLED SOLID STATE STARTER - BLOCK DIAGRAM

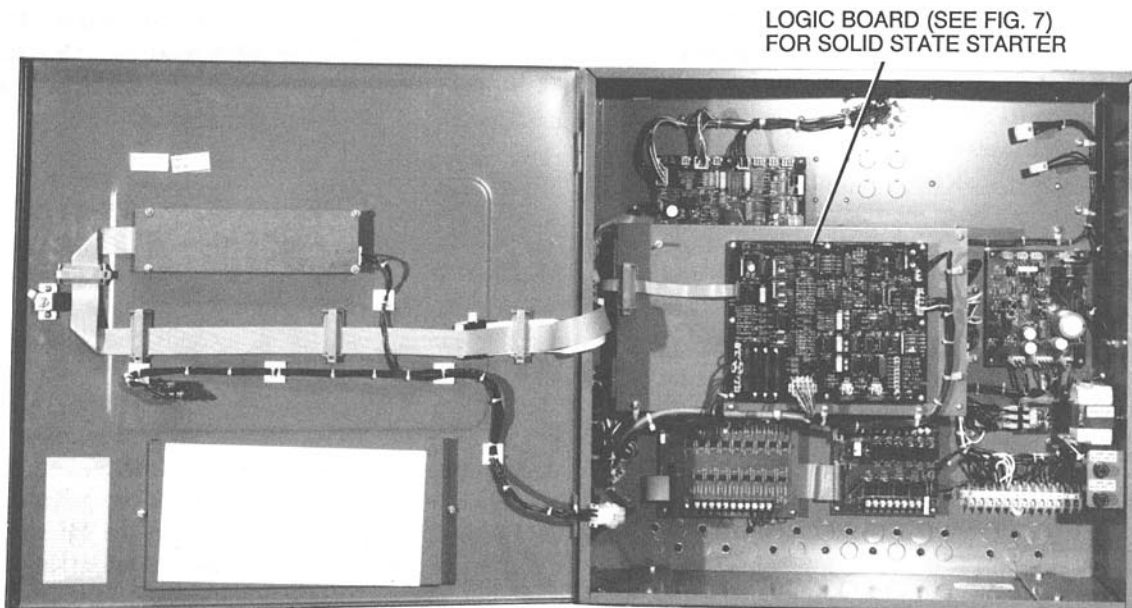

FIG. 4 – MICROCOMPUTER CONTROL CENTER - DOOR OPEN - SOLID STATE STARTER APPLICATION

## SECTION 3

### SYSTEM ARCHITECTURE

The following Liquid Cooled Solid State Starter components are located in an enclosure mounted to the compressor motor terminal box:

- SCR Assemblies
- Current Transformers
- Control Circuit Fuses
- Trigger Board
- Trigger Board Transformer (3-phase Delta)

A control power transformer is attached to the side of the starter enclosure. This supplies 115VAC control power to the starter and MicroComputer Control Center.

The starter logic board is mounted on a hinged door inside the MicroComputer Control Center. (See FIG. 4)

---

## SECTION 4

### LOGIC BOARD

Located in the MicroComputer Control Center  
(Refer to FIG. 5, 6 and 7)

Three current transformers, located in the Solid State Starter, sense motor current and provide motor current signals to the Logic Board. These current signals are combined, buffered and applied to the power fault detector, 105% FLA detector, current limit detectors, fault current detector and delay angle (VCON) generator.

The **POWER FAULT DETECTOR** prevents compressor damage due to a momentary interruption of motor current (transient torque condition). This condition is normally caused by AC power line abnormalities. The motor current signal applied to the power fault detector is calibrated by the **OVERLOAD** pot. When the power fault detector senses that the motor current has decreased to 15% FLA, its output initiates a 1 second pulse from the monopulse circuit and simultaneously latches on the "power fault" LED and initiates a "lockout" to shut off gate pulses from the Trigger Board. The LED will remain illuminated until manually reset with the **RESET** pushbutton. The output of the monopulse circuit causes relay K1 to de-energize for 1 second and then re-energize. Relay K1 contacts open for 1 second and then re-close. Since the relay K1 contacts are interfaced to the motor controller circuit of the MicroComputer Control Center, the Micro Board interprets this 1 second interruption as a LCSSS initiated "power fault" shutdown and displays **MON XX:XXAM-POWER FAULT-AUTOSTART** on the keypad display. Simultaneously, the Micro Board initiates a chiller shutdown. After the 150 second coastdown period (centrifugal chiller) or 2 minute lockout delay (screw chiller), the Micro Board automatically initiates a chiller start sequence if the **COMPRESSOR** switch is in the "RUN" position. The power fault detector circuit is inhibited for the first 4-17 seconds (7 seconds nominal) of chiller run time. To initiate a chiller start, the MicroComputer Control Center applies a start signal to the Logic Board. When the start signal is received, it starts a 4-17 second inhibit timer. At the com-

pletion of the timing sequence, the power fault detector is permitted to operate.

The **HALF PHASE DETECTOR** (Rev "D" and later Logic Boards) detects when one-half cycle (positive or negative half cycle) of one phase (A, B, or C) of current is not conducted to the compressor motor. To eliminate nuisance trips, the detector will not produce an output until it has detected 128 missing half cycles in 2 consecutive seconds. If this criteria is met, the detector output transitions for 1 to 2 seconds causing relay K1 to de-energize (open) for 1 to 2 seconds. This causes the chiller to shut down and display **MON XX:XXAM - POWER FAULT - AUTOSTART** on the MicroComputer Control Center keypad display. Simultaneously, the "Half Phase" LED is illuminated via the latch circuit and will remain illuminated until reset with the **RESET** pushbutton located on the Logic Board. Following the 150 second coastdown period (centrifugal chiller) or 2 minute lockout period (screw chiller), the chiller will automatically restart if the **COMPRESSOR** switch is in the **RUN** position. This **HALF PHASE** condition can be caused by a defective starter component or AC powerline disturbance.

The **105% FLA DETECTOR** receives the motor current signal that has been calibrated by the **OVERLOAD** pot. When the motor current reaches 105% FLA, the detector causes the 105% FLA LED to illuminate and starts a 40 second timer. If the motor current remains at 105% FLA or greater continuously for 40 seconds, the timer output causes the "OVERLOAD" LED to latch on and K1 relay to de-energize. The "OVERLOAD" LED will remain illuminated and K1 relay will remain de-energized until manually reset with the **RESET** pushbutton. Since the relay K1 contacts are interfaced to the motor controller circuit of the MicroComputer Control Center, the Micro reads the opening of this circuit and initiates a system shutdown. **MON XX:XXAM MOTOR CONTROLLER-EXT RESET** is displayed on the MicroComputer Control Center keypad display. As long as relay K1 contacts are open (de-energized) the Micro will prevent a re-start of the

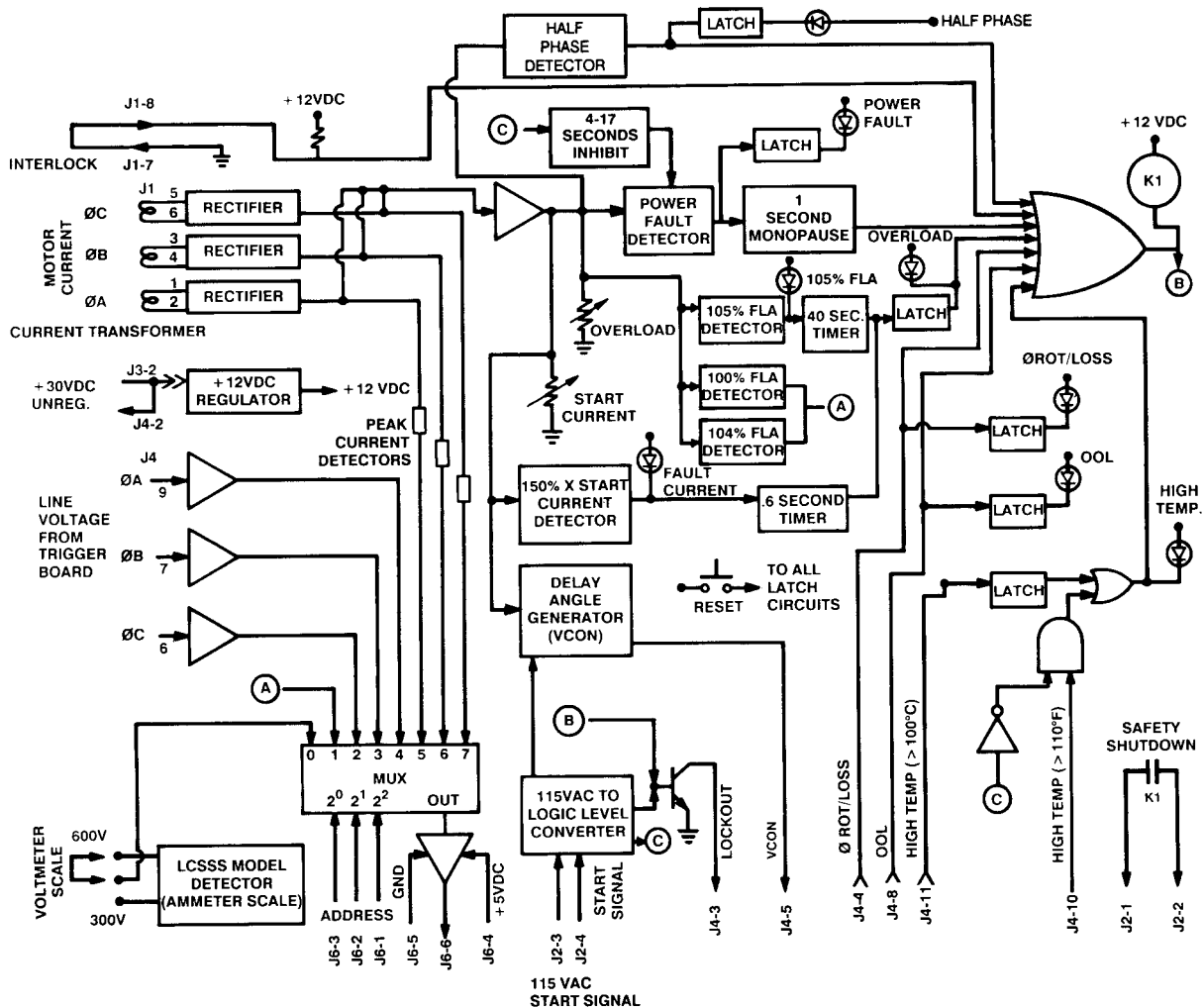

FIG. 5 - LIQUID COOLED SOLID STATE STARTER - LOGIC BOARD BLOCK DIAGRAM

chiller. Restart will occur automatically if the COMPRESSOR switch is in "RUN" position when the Logic Board RESET pushbutton is pressed, (See Fig. 7, page 9), energizing K1 relay and causing the K1 contacts to close.

When the motor current, as calibrated by the OVERLOAD pot., reaches 100% FLA the 100% FLA DETECTOR output transitions from greater than 3.45VDC to 1.21-3.45VDC. This output is applied to channel #1 of the logic board multiplexer (MUX). Under program control, the Micro Board reads this command by addressing MUX channel #1. The Micro Board prevents the vanes from further opening until the 100% FLA detector output transitions to >3.46VDC. This occurs at 98% FLA. When the Micro Board reads MUX channel #1 again, it sees this new command and allows the vanes to open. If the motor current increases to 104% FLA, the 104% FLA DETECTOR transitions to <1.20VDC. When the Micro Board reads MUX channel #1, this new command causes the micro to drive the vanes closed. The vanes will continue to be driven closed until the 104% Detector transitions to 1.21-3.45VDC at 102% FLA.

If the motor current ever reaches 150% of the calibrated start current (45% X Delta LRA), the 150% OF START

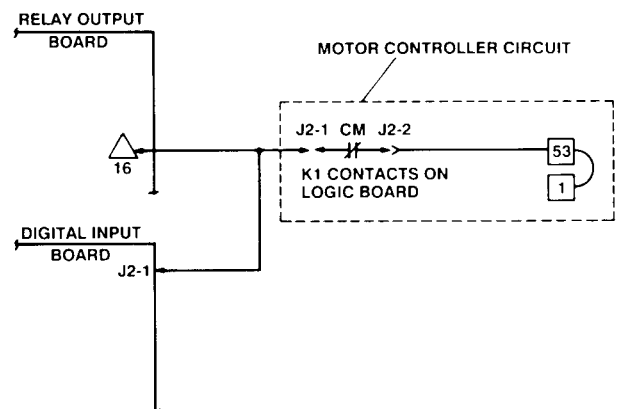
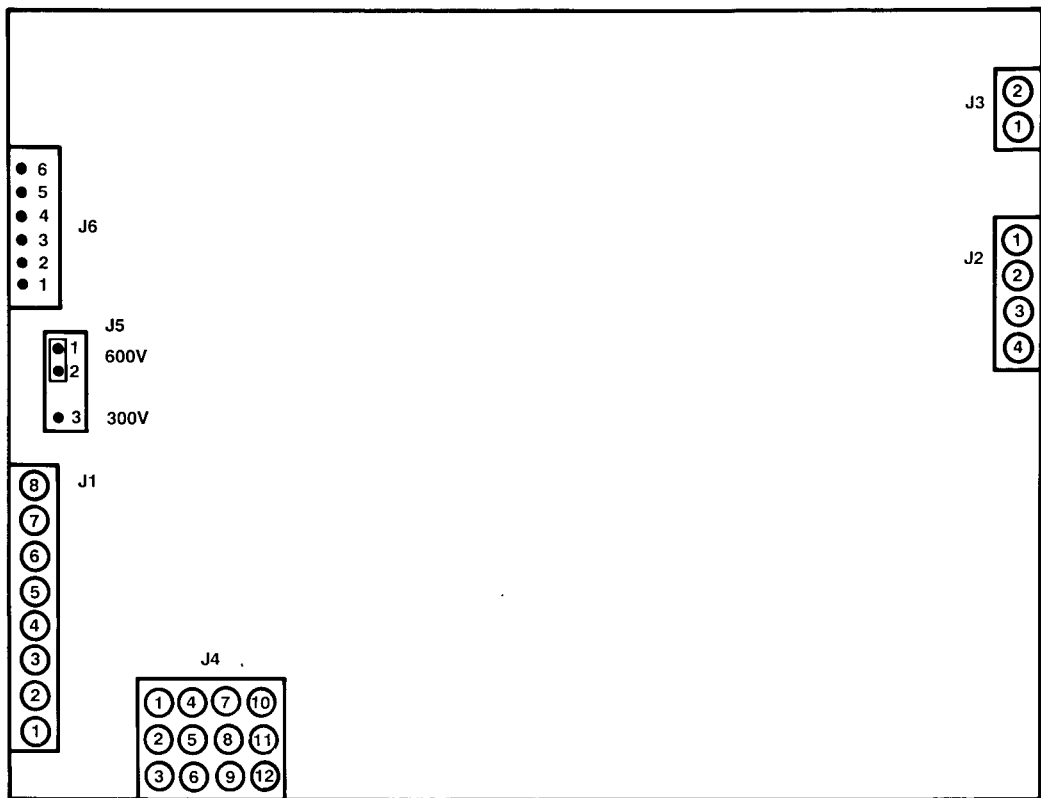

FIG. 5A - MICROCOMPUTER CONTROL CENTER - MOTOR CONTROLLER CIRCUIT

CURRENT DETECTOR output causes the "fault current" LED to illuminate and start the 0.6 second timer. At the completion of the timing sequence, the timer output causes the latch circuit to illuminate the "OVERLOAD" LED and de-energize K1 relay. The "OVERLOAD" LED will remain illuminated and K1 relay will remain de-energized until the latch circuit is manually reset with the RESET pushbutton. Since K1 relay contacts are interfaced to the

SECTION 3  
SECTION 4



**FIG. 6 – LOGIC BOARD PLUG - PIN LOCATION DIAGRAM**

MicroComputer Control Center motor controller circuit, the opening of K1 contacts causes the Micro Board to initiate a system shutdown and display **MON XX:XXAM MOTOR CONTROLLER-EXT RESET** on the keypad display. As long as K1 contacts remain open the Micro Board will prevent a system restart. However, restart will occur automatically if COMPRESSOR switch is in "RUN" position when the Logic Board RESET pushbutton is pressed, energizing K1 relay causing the K1 contacts to close.

The **DELAY ANGLE (OR VCON) GENERATOR** produces a DC voltage that is applied to the **Trigger Board**. This signal determines the firing angle of the gate pulses to the SCR's. When the LCSSS is commanded to start, the delay angle generator receives the start signal via the **115VAC TO LOGIC LEVEL CONVERTER**. The delay angle generator outputs a voltage ( $\approx 4.0$  VDC) that causes the trigger board to turn-on the SCR's at a phase-back point on the 3 $\emptyset$  AC powerline sinewave ( $\approx 90^\circ$ ). This point is determined by the setting of the **Start Current** pot. to limit the motor starting current to the proper value (45% X Delta LRA). As the compressor motor accelerates to synchronous speed, the motor current decreases at approximately the rate of acceleration. As the motor current decreases, the delay angle voltage increases at the same rate to a maximum level ( $\approx 9$  VDC) reached at synchronous speed. At this point the SCR's are turned on during the full power line cycle.

The **Lockout** output of the Logic Board determines if the Trigger Board will be enabled or inhibited. When the Trigger Board is enabled, it provides gate pulses to turn-on the SCR's. When the Trigger Board is inhibited, no gate pulses are applied to the SCR's. Therefore, the motor will not run. To start the compressor motor, the Micro-Computer Control Center sends a 115VAC start signal to the Logic Board. The **115VAC To Logic Level Converter** turns on the lockout transistor driving the lockout control line to ground potential. This enables the Trigger Board. To shut down the compressor motor, the MicroComputer Control Center removes the 115VAC start signal. The lockout transistor turns off causing the lockout control line to go to +12VDC. This inhibits the Trigger Board. The lockout output also controls the operation of the SCR assembly cooling loop water pump. (Refer to Trigger Board explanation, page 13, for description of water pump control.) Finally, anytime the Logic Board or Trigger Board initiates a chiller shutdown, the lockout transistor is turned off causing an immediate inhibiting of the Trigger Board SCR gate pulses.

Two safety circuits, located on the Trigger Board check: AC power line  $\emptyset$  **Rotation/Loss** and Trigger Board **Out Of Lock (OOL)** conditions. If the Trigger Board detects a problem with either of these conditions, the appropriate Logic Board input is driven to +12VDC for 1 second. This causes the appropriate LED to be latched on and relay K1 to de-energize for 1 second. The LED will

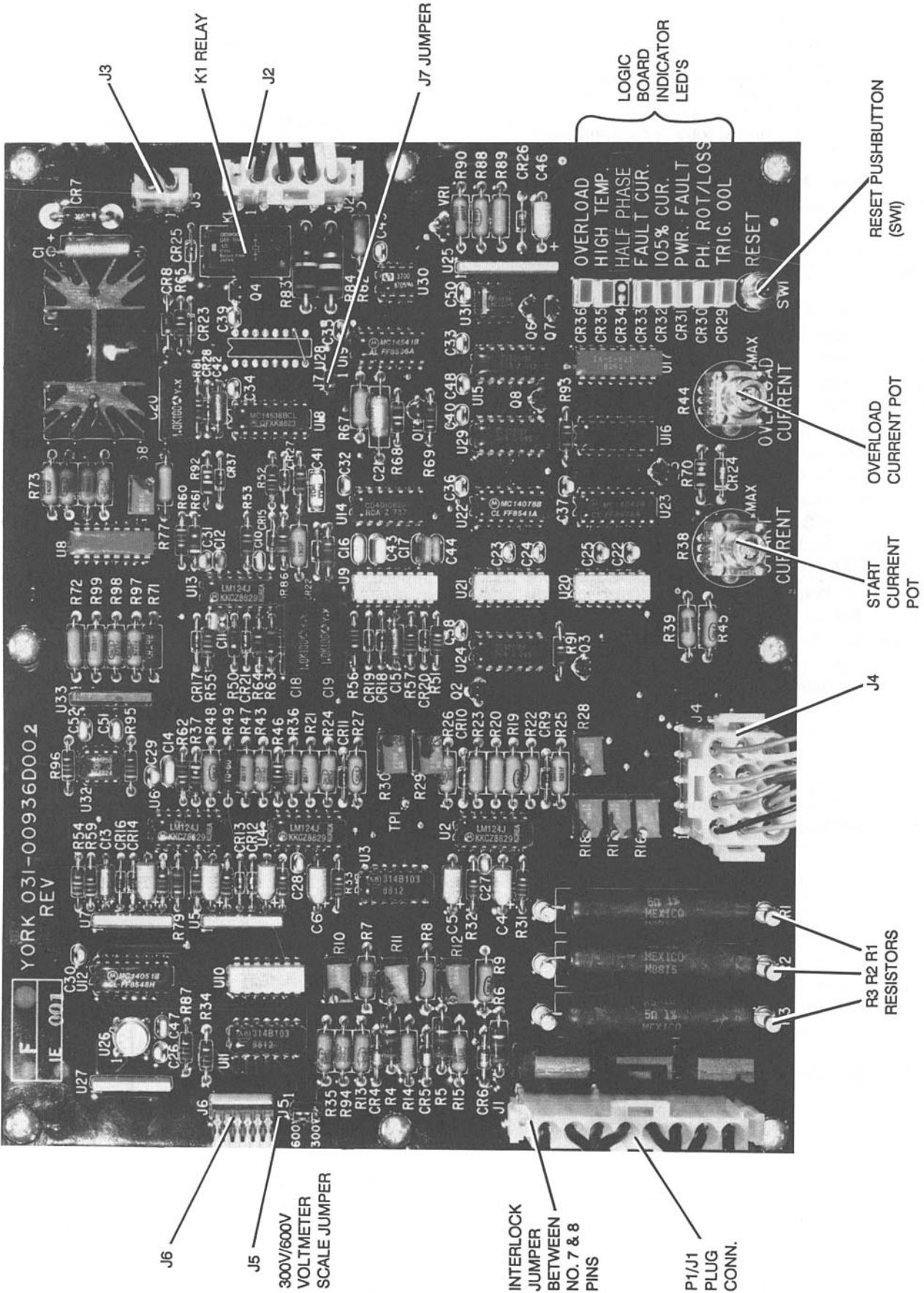

FIG. 7 — LOGIC BOARD (LOCATED IN MICROCOMPUTER CONTROL CENTER)

remain illuminated until the latch circuit is manually reset with the **RESET** pushbutton. (Located on Logic Board). The opening of K1 relay contacts will be sensed by the Micro Board as explained earlier and a shutdown is initiated and **MON XX:XXAM POWER FAULT – AUTOSTART** is displayed on the keypad display. Relay K1 will be re-energized within 1 second by the appropriate input to the Logic Board being driven to ground potential by the Trigger Board. The Micro Board senses the closing of K1 contacts and automatically initiates a chiller restart if the **COMPRESSOR** switch is in the "RUN" position. Refer to Trigger Board explanation, page 13, for description of "Ø ROT/LOSS" and "OOL".

The Trigger Board monitors the temperature of the three SCR heatsink assemblies with a thermistor attached to each assembly. When that board detects that the temperature of any assembly exceeds 100°C it drives the Logic Board input (J4-11) to +12VDC. This latches on the High Temp LED and de-energizes K1 relay. The LED will remain illuminated and K1 will remain de-energized until the latch is manually reset with the **RESET** pushbutton (Located on Logic Board). The opening of K1 contacts is sensed by the Micro Board in the manner previously explained and the Micro Board initiates a chiller shutdown.

**MON XX:XX AM MOTOR CONTROLLER-EXT RESET** is displayed on the keypad display. The Micro Board will not allow a chiller restart until K1 contacts close. This occurs when the Trigger Board detects the heatsink temperature falls below 110°F and the **RESET** (Located on Logic Board) pushbutton is pressed. The Trigger Board will transition the Logic Board input (J4-11) to ground potential when the heatsink temperature falls below 110°F. When the **RESET** (Located on Logic Board) pushbutton is pressed K1 relay is again energized, the contacts close causing the Micro Board to automatically initiate a chiller restart if the **COMPRESSOR** switch is in the "RUN" position.

When the temperature of any SCR heatsink assembly exceeds 110°F the MicroComputer Control Center will be inhibited from starting the chiller. The Trigger Board drives the Logic Board input (J4-10) to +12 VDC when this threshold is exceeded. This causes the High Temp LED to illuminate and relay K1 to de-energize. The opening of K1 contacts interrupts the MicroComputer Control Center motor controller circuit. **MON XX:XX AM**

**MOTOR CONTROLLER-EXT RESET** is displayed. As long as the motor controller circuit (FIG. 5A) is interrupted the Micro Board will inhibit a chiller start. When the Trigger Board detects the heatsink temperature falling below 110°F it drives the Logic Board input (J4-10) to ground potential. This causes the High Temp LED to extinguish and K1 to energize. The closing of K1 contacts completes the motor controller circuit and the Micro Board automatically initiates a chiller start if the **COMPRESSOR** Switch is in the "RUN" position. Typically, when the chiller is shut down after having been running at 75%-100% FLA the heatsink temperature will exceed 110°F for

a few minutes after shutdown. The cooling loop water pump will run during this time to cool the SCR assemblies. Refer to description of Trigger Board for explanation, page 13, of cooling loop water pump operation.

Phase "A", "B", and "C" motor current analog signals are input to the multiplexer (MUX) channels 5, 6 and 7 respectively. Under program control, the Micro Board reads these motor current values by addressing the MUX. The Micro Board displays these values on the keypad display, checks for current unbalance and uses the highest of these values to perform current limit functions. (Refer to Micro-Computer Control Center description in Form referenced on Page 2).

Phase "A", "B" and "C" AC power line voltage analog values are inputs to MUX channels 4, 3 and 2 respectively. Under program control, the Micro Board reads these values by addressing the MUX. The Micro Board displays these values on the keypad display and initiates a system shutdown if any phase falls below a minimum threshold. (Refer to MicroComputer Control Center description in Form referenced on Page 2.)

In order for the motor current and AC line voltage to be accurately displayed by the Micro Board, a reference voltage is applied to MUX channel 0. Under program control, the Micro Board reads this voltage by addressing the MUX. This voltage is a result of the output of the **LCSSS Model Detector Circuit** and the position of the **300V/600V** voltmeter scale jumper. The model detector circuit output is an analog voltage representing the maximum current capability (ammeter full scale) of the starter being used. The position of the **300V/600V** jumper determines the full scale voltage of the Micro Board "Voltmeter" display. Therefore, the combined output of this circuit tells the Micro Board the maximum amps and volts that can be displayed for a given starter application. This is necessary because there are four different models (sizes) of Liquid Cooled Solid State Starters (7L, 14L, 26L, 33L). Each model has a different current capability as follows:

MODEL	MIN. FLA	MAX. FLA	MAX LRA	MAX. START CURRENT	MAX. DISPLAY AMPS
7L	100	260	1556	700	750
14L	150	510	3111	1400	1500
26L	250	850	5780	2600	2800
33L	430	1050	7335	3300	3500

Also, within these model classifications, there are various line voltage applications. The available 60Hz voltage applications are 200/208, 220/230/240, 440/460/480 and 550/575/600. One 50Hz voltage application is available at 380/400/415. The LCSSS model numbers reflect this classification as follows on Page 11.

There are four different Logic Boards for the LCSSS. Each model (7L, 14L, 26L, 33L) uses a different Logic Board. Each of these Logic Boards outputs a unique voltage from

MODEL	LINE VOLTAGE APPLICATION (VAC)
7L-46 7L-58 7L-50	440/460/480 550/575/600 380/400/415
14L-17 14L-28 14L-46 14L-58 14L-50	200/208 220/230/240 440/460/480 550/575/600 380/400/415
26L-17 26L-28 26L-46 26L-58 26L-50	200/208 220/230/240 440/460/480 550/575/600 380/400/415
33L-17 33L-28 33L-46 33L-50	200/208 220/230/240 440/460/480 380/400/415

the LCSSS model detector circuit for ammeter full scale. The 300V/600V jumper (J5) is then placed in the appropriate position for the AC power line application. When used on 200/208 and 220/230/240 VAC applications, the jumper on J5 should be placed in the 300V position. When used on 440/460/480, 550/575/600 and 380/400/415 VAC applications the jumper on J5 must be placed in the 600V position. On new chiller start-ups this jumper is in the appropriate position as received from the YORK Factory. However, if the Logic Board is field replaced the service technician must place the jumper in the proper position. (See FIG.'s 6 & 7, Pages 8 & 9).

For proper operation, the motor current detection circuits require that the current transformers are connected to the Logic Board. The current transformers are connected to the Logic Board via P1/J1. To assure that P1 is connected to J1, an interlock circuit is employed. Connector P1 contains a jumper between pins 7 and 8. When P1 is connected to J1, pin 8 is shorted to ground via the jumper in P1. This allows relay K1 relay to remain energized. However, if P1 is not connected, pin 8 floats to +12VDC. This causes relay K1 to de-energize, interrupting the MicroComputer Control Center motor controller circuit (FIG. 5A). The Micro Board will initiate a system shutdown and display **MON XX:XX AM MOTOR CONTROLLER-EXT RESET** on the keypad display. The chiller will not be allowed to start until connector P1 is connected to J1.

#### LOGIC BOARD INDICATOR LED'S (Refer to FIG. 7)

- **OVERLOAD**—indicates the system is shutdown because the motor current has exceeded 150% of starting current (45% X Delta LRA) for .6 seconds or 105% FLA for 40 seconds. Reset with RESET pushbutton.
- **HIGH TEMP**—indicates the system is shutdown because the temperature of an SCR heatsink assembly has exceeded 100°C. Reset with RESET pushbutton. Also indicates the system is shutdown and the temperature of an SCR heatsink assembly exceeds 110°F. Typically,

the temperature will exceed 110°F immediately after any shutdown if the starter was running in a high temperature environment under heavy current load. The cooling loop water pump will continue to run after system shutdown to cool the SCR heatsink assemblies. When the temperature decreases below 110°F, the LED will automatically extinguish. The chiller will be prevented from starting while this LED is illuminated.

- **HALF PHASE** — Indicates that 1/2 cycle (positive or negative half cycle) of 1 phase (A, B, or C) of AC powerline current was not conducted to the compressor motor for a period of 2 continuous seconds while the chiller was running. This could be caused by a defective starter component or an AC powerline disturbance. The chiller will automatically restart. The LED will remain illuminated until the **RESET** pushbutton is pressed.
- **FAULT CUR. (Fault Current)**—indicates the motor current has exceeded 150% of starting current (45% X Delta LRA). This is a non-latching indicator that only illuminates for about 1 second when this fault occurs.
- **105% CURRENT**—indicates the motor current is equal to or greater than 105% FLA.
- **PWR. FAULT (Power Fault)** — indicates the motor current has decreased to less than 15% FLA. This initiated a "power fault" shutdown and the chiller automatically restarted. Press **RESET** pushbutton to extinguish. This shutdown is typically caused by an AC power line disturbance.
- **PH. ROTATION/LOSS**—indicates there is, or was a system shutdown caused by an AC power line phase rotation problem, or a loss of voltage in a phase. If this occurs while the chiller is running, the chiller will shutdown and automatically restart. If this problem is detected while chiller is not running, chiller will be prevented from starting until problem clears. Press **RESET** pushbutton to extinguish.
- **TRIG. OOL (Trigger Out Of Lock)**—indicates there is or was a system shutdown caused by a disturbance on phase "A" of the AC power line, or Trigger Board failure. If this occurs while the chiller is running, the chiller will shut down and automatically restart. If this problem is detected while chiller is not running, chiller will be prevented from starting until problem clears. Press **RESET** pushbutton to extinguish.

#### LOGIC BOARD INPUTS AND OUTPUTS (Refer to FIG.'s 6 and 7)

*NOTE: All measurements made to GND (J3-1) unless otherwise noted.*

#### J1-PINS

- J1-1/2** Phase "A" motor current input from J1 current transformer (2T). DC voltage is read with digital

voltmeter across resistor R1 (bottom of R1 is GND). Voltage read should be:

$$VDC = \frac{I_{MOTOR} \times 1.414}{CT \text{ RATIO}} \times 5 \times \frac{2}{3.14}$$

I = motor current in phase  
 CT ratio = 700(7L), 1400(14L)  
 2600(26L), 3300(33L)

- J1-3/4** Phase "B" motor current input from current transformer (3T). DC voltage is read across resistor R2 (bottom of R2 is GND). Refer to J1-1/2 to calculate voltage.
- J1-5/6** Phase "C" motor current input from current transformer (4T). DC voltage is read across resistor R3 (bottom of R3 is GND). Refer to J1-1/2 to calculate voltage.
- J1-7** GND. Part of current transformer connector interlock.
- J1-8** Current transformer connector interlock circuit. 0VDC when connector P1 connected to Logic Board J1; +12VDC when P1 not connected.

### 2-PINS

- J2-1** One side of safety shutdown relay K1 contacts. Connected to MicroComputer Control Center "motor controller" circuit. 115VAC as measured to TB5-2 (MicroComputer Control Center) when Logic Board will allow chiller to run.
- J2-2** One side of safety shutdown relay K1 contacts. Connected to MicroComputer Control Center "motor controller" circuit. 115VAC as measured to TB5-2 (MicroComputer Control Center).
- J2-3** Start signal input. 115VAC as measured to J2-4.
- J2-4** 115VAC neutral (grounded conductor).

### J3-PINS

- J3-1** Power supply input ground (GND).
- J3-2** +30VDC unregulated power supply input.

### J4-PINS

- J4-1** GND.
- J4-2** +30VDC unregulated to Trigger Board.
- J4-3** Lockout output to Trigger Board. 0VDC when Logic Board is commanding Trigger Board to provide gate pulses to SCR's to run compressor motor. Otherwise +12VDC.
- J4-4** Phase ROT/LOSS input from Trigger Board. +12VDC when Trigger Board detects a phase

rotation problem, or loss of AC power line voltage in any phase. Otherwise, 0VDC.

- J4-5** VCON (delay angle) output to Trigger Board. Approximately 4VDC at compressor start. Increases to approximately 9VDC at the same rate as motor current decreases.
- J4-6** Phase "C" AC power line input from Trigger Board. Refer to Trigger Board inputs and outputs J1-6 for voltage.
- J4-7** Phase "B" AC power line input from Trigger Board. Refer to Trigger Board inputs and outputs J1-6 for voltage.
- J4-8** OOL (Out Of Lock) signal from Trigger Board. +12VDC when Trigger Board is Out Of Lock. 0VDC otherwise.
- J4-9** Phase "A" AC power line input from Trigger Board. Refer to Trigger Board inputs and outputs J1-6 for voltage.
- J4-10** High Temp (> 110°F) input from Trigger Board. +12VDC when Trigger Board detects any SCR heatsink temperature exceeds 110°F. Otherwise 0VDC.
- J4-11** High Temp (> 100°C) input from Trigger Board. +12VDC when any SCR heatsink temperature exceeds 100°C. Otherwise 0VDC.
- J4-12** Cable shield (GND).

### J5-PIN

- J5**

1	600V	Jumper placed in 600V position when used on 440/460/480, 550/575/600 and 380/400/415 VAC applications.
2		
3	300V	
  
- |   |      |  |
|---|------|--|
| 1 | 600V | Jumper placed in 300V position when used on 200/208 or 220/230/240 VAC applications. |
| 2 |      |  |
| 3 | 300V |  |

### J6-PINS

- J6-1** 2<sup>2</sup> address bit from Micro Board. +12VDC in active state. Otherwise, 0VDC.
- J6-2** 2<sup>1</sup> address bit from Micro Board. +12VDC in active state. Otherwise, 0VDC.
- J6-3** 2<sup>0</sup> address bit from Micro Board. +12VDC in active state, otherwise, 0VDC.
- J6-4** +5VDC Regulated from Micro Board.
- J6-5** GND. from Micro Board.

## J6-6 Multiplexed 0-5VDC output to Micro Board as follows:

ADDRESS	DATA															
000	STARTER MODEL—7L, 14L, 26L, 33L, (ammeter scale) and voltmeter full scale as follows:  7L/300VAC = .294VDC NOMINAL 14L/300VAC = 1.00VDC NOMINAL 26L/300VAC = 2.09VDC NOMINAL 33L/300VAC = 3.48VDC NOMINAL 7L/600VAC = .594VDC NOMINAL 14L/600VAC = 1.50VDC NOMINAL 26L/600VAC = 2.75VDC NOMINAL 33L/600VAC = ≥ 3.88VDC NOMINAL															
001	Current limit commands as follows:  < 98%FLA = ≥ 3.46VDC ≥ 100%FLA = 1.21-3.45VDC 104%FLA = < 1.20VDC															
010	Phase "C" AC line voltage analog Value (DC) as follows:  300VAC scale = $V_{out} (DC) = \frac{VAC}{67.9}$  600VAC scale = $V_{out} (DC) = \frac{VAC}{135.8}$															
011	Phase "B" AC line voltage analog value. Refer to address 010.															
100	Phase "A" AC line voltage analog value. Refer to address 010.															
101	Phase "A" motor current analog value. 0-4.7VDC analog voltage. Linear between 0-4.7VDC. Factory calibrated to provide the following at full scale amps.															
	<table border="1"> <thead> <tr> <th>MODEL</th> <th>FULL SCALE AMPS</th> <th>OUTPUT</th> </tr> </thead> <tbody> <tr> <td>7L</td> <td>750A</td> <td>4.7VDC</td> </tr> <tr> <td>14L</td> <td>1500A</td> <td>4.7VDC</td> </tr> <tr> <td>26L</td> <td>2800A</td> <td>4.7VDC</td> </tr> <tr> <td>33L</td> <td>3500A</td> <td>4.7VDC</td> </tr> </tbody> </table>	MODEL	FULL SCALE AMPS	OUTPUT	7L	750A	4.7VDC	14L	1500A	4.7VDC	26L	2800A	4.7VDC	33L	3500A	4.7VDC
MODEL	FULL SCALE AMPS	OUTPUT														
7L	750A	4.7VDC														
14L	1500A	4.7VDC														
26L	2800A	4.7VDC														
33L	3500A	4.7VDC														
110	Phase "B" motor current analog value. Refer to address 101.															
111	Phase "C" motor current analog value. Refer to address 101.															

## TRIGGER BOARD (Refer to FIG.'s 8, 9, and 10)

The primary of a 3-phase delta step-down transformer is connected to the 3-phase AC power line that supplies power to the compressor motor. The transformer second-

ary is connected to the Trigger Board. Phase "A" is applied to the **Phase Detector/Comparator** circuit. The output of this circuit drives a voltage controlled oscillator (VCO) that produces pulses that are in phase with phase "A" of the AC power line. To assure that the VCO output is in phase with the AC power line, the VCO output is input to the **Phase Detector/Comparator**. The phase "A" power line sinewave is compared to the VCO output and if a phase difference exists, the OOL (Out of Lock) output (J1-8) generates 2 second long +12VDC pulses for as long as the difference exists. The OOL output is applied to the Logic Board and the Logic Board initiates a chiller shutdown.

Phase "B" and "C" transformer secondaries and the VCO output are applied to the **Phase ROT/LOSS Section**. This circuit determines if all phases are present and the phase rotation is correct. If any phase is missing or if the phase rotation is incorrect, the **Phase ROT/LOSS Section** drives the **ØROT/LOSS** output (J1-4) to +12VDC for as long as the problem exists. This output is applied to the **Logic Board** and the **Logic Board** initiates a chiller shutdown.

The **Trigger Board** generated phase "A" pulses (VCO Output) are applied to the **3-Phase Pulse Generator**. From the phase "A" reference input, this circuit generates 3-phase SCR gate enable pulses. A pulse is generated for the positive half cycle and negative half cycle SCR for each phase. The VCON signal (J1-5) from the **Logic Board** determines the delay angle of the pulses (Refer to explanation under description of **Logic Board** page 7). These pulses are applied to the respective **Gate Pulse Generators** for each phase. The outputs of these circuits provide the gate pulses to the SCR's. When gate pulses are present the SCR's conduct and allow current to flow to the compressor motor. When the MicroComputer Control Center commands the starter to run the compressor motor, the **Logic Board** drives the **Lockout** input (J1-3) to ground potential. This enables the **3-Phase Pulse Generator**. A stop command causes the **Logic Board** to drive the **Lockout** input to +12VDC. This disables the gate pulses causing the SCR's to turn-off.

SCR heatsink temperature is sensed by a thermistor located on each heatsink assembly. These thermistors are connected to the **SCR Assembly Temperature Detector** circuit. If the temperature of any assembly exceeds 100°C, the High Temp. output (J1-11) (100°C) to the **Logic Board** is driven to +12VDC to cause the **Logic Board** to initiate a chiller shutdown. This is a safety shutdown and the **Logic Board** will prevent a chiller restart until manually reset. (Refer to description of **Logic Board** page 8). If the chiller is shutdown and the temperature exceeds 110°F, the High Temp. (110°F) (J1-10) output to the **Logic Board** is driven to +12VDC. This causes the **Logic Board** to prevent the chiller from starting until the output is driven to ground potential. This occurs when the temperature falls below 110°F. (Refer to description of **Logic Board** page 10). To expedite the cooling of the SCR heatsinks during this

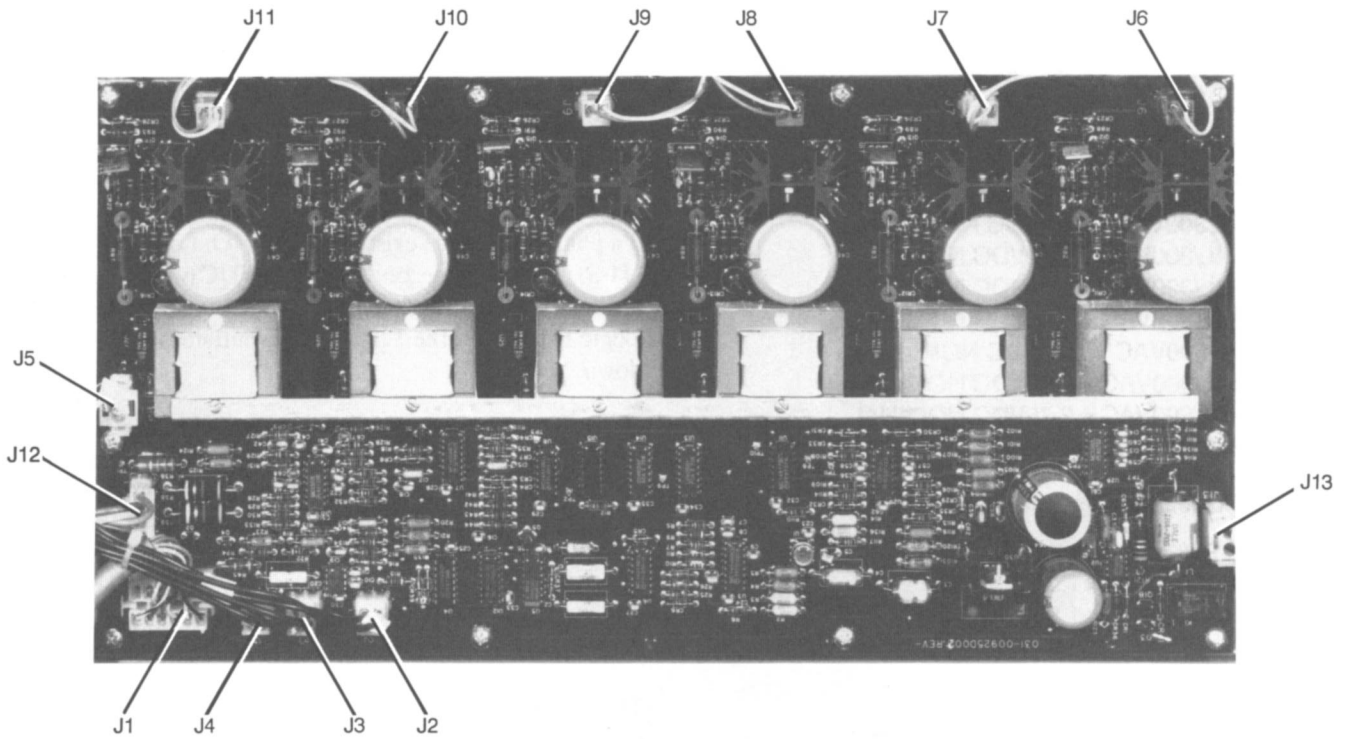

FIG. 8 – TRIGGER BOARD

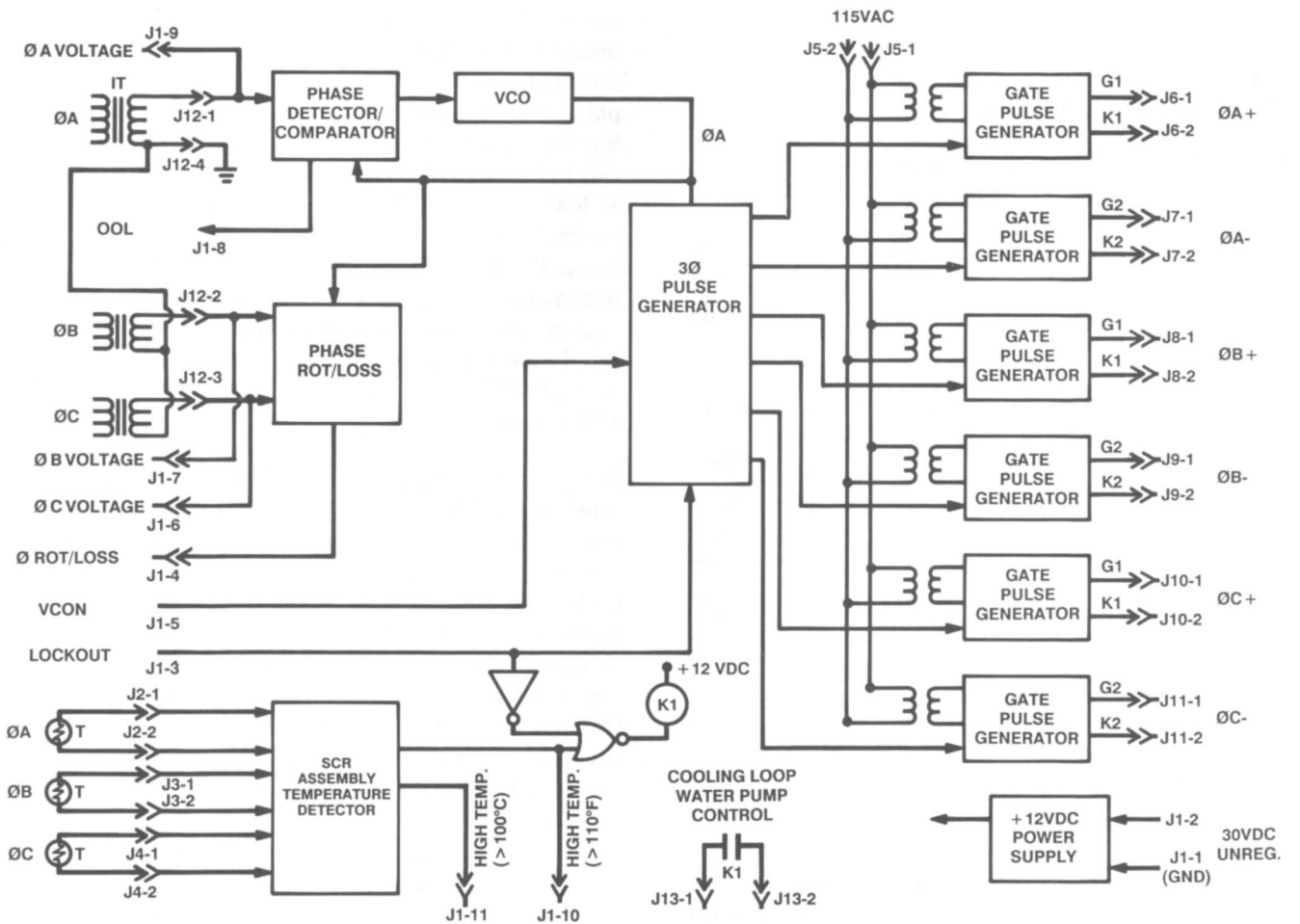

FIG. 9 – TRIGGER BOARD – BLOCK DIAGRAM

period, the **SCR Assembly Temperature Detector** energizes K1 Relay to run the cooling loop water pump until the temperature falls below 110°F.

Relay K1 controls the operation of the cooling loop water pump. The lockout signal (J1-3) from the **Logic Board** transitions to ground potential to start the compressor motor. This causes relay K1 to energize closing K1 contacts. As long as K1 contacts are closed the pump will run. When the lockout signal transitions to +12VDC to shut-down the chiller, K1 de-energizes, (provided the thermistor temperature is below 110°F), opening the K1 contacts. This stops the pump. Therefore, the cooling loop water pump may start and stop with the compressor motor. Finally, as detailed earlier, K1 relay will be energized by the **SCR Assembly Temperature Detector** any time any heatsink temperature exceeds 110°F. This causes the pump to run. When the temperature falls below 110°F, the temperature detector de-energizes K1 relay causing the pump to stop.

### TRIGGER BOARD - Inputs and Outputs (Refer to FIG.'s 8-10)

*NOTE: Unless otherwise noted all measurements made to GND. (J1-1)*

#### J1-PINS

- J1-1** Power supply input, GND.
- J1-2** Power supply input, 30VDC unregulated from logic board.
- J1-3** **LOCKOUT** input from **Logic Board**. 0VDC to run compressor motor. +12VDC to stop compressor.
- J1-4** **PHASE ROT/LOSS** output. +12VDC when phase rotation or loss of phase problem. Otherwise 0VDC.
- J1-5** **VCON** (Delay Angle) output. Approximately 4VDC at compressor start. Increases to approximately 9VDC at the same rate as motor current decreases.
- J1-6** Phase "C" AC power line output to **Logic Board**.  
200VAC applications = 9.52-12.18VAC  
230VAC applications = 10.95-14.11VAC  
460VAC applications = 10.95-14.11VAC  
575VAC applications = 13.70-16.97VAC  
400VAC(50Hz)applications = 9.05-12.21VAC
- J1-7** Phase "B" AC power line output to **Logic Board**. See J1-6 for voltage.
- J1-8** **Out of Lock (OOL)** output. +12VDC when **Trigger Board** is out of lock. 0VDC otherwise.
- J1-9** Phase "A" AC power line output to **Logic Board**. See J1-6 for voltage.
- J1-10** **High Temp** (>110°F) output to **Logic Board**.

+12VDC when any SCR heatsink temperature exceeds 110°F. Otherwise 0VDC.

- J1-11** **High Temp** (>100°C) output to **Logic Board**. +12VDC when any SCR heatsink temperature exceeds 100°C. Otherwise 0VDC.
- J1-12** Cable shield. Not connected at **Trigger Board**. Connected to GND. at **Logic Board**.

#### J2-PINS

- J2-1** Phase "A" SCR assembly thermistor input. 8.8VDC-11VDC @ room temperature (100°F-55°F) measured to J2-2. Thermistor resistance is 5.3K OHMS-20K OHMS @ 100°F-55°F. Ref. Table 1.
- J2-2** See J2-1.

#### J3-PINS

- J3-1** Phase "B" SCR assembly thermistor input. Measured to J3-2. See J2-1 for voltage.
- J3-2** See J3-1.

#### J4-PINS

- J4-1** Phase "C" SCR assembly thermistor input. Measured to J4-2. See J2-1 for voltage.
- J4-2** See J4-1.

#### J5-PINS

- J5-1** 115VAC input.
- J5-2** 115VAC neutral input.

#### J6-PINS

- J6-1** Phase "A" upper SCR gate output. 1-3VAC as measured to J6-2.
- J6-2** Phase "A" upper SCR cathode. See J6-1.

#### J7-PINS

- 7-1** Phase "A" lower SCR gate output. 1-3VAC as measured to J7-2.
- J7-2** Phase "A" lower SCR cathode. See J7-1.

#### J8-PINS

- J8-1** Phase "B" upper SCR gate output. 1-3VAC as measured to J8-2.
- J8-2** Phase "B" upper SCR cathode. See J8-1.

#### J9-PINS

- J9-1** Phase "B" lower SCR gate output. 1-3VAC as measured to J9-2.

**TABLE 1 – LCSSS - SCR THERMISTOR CHARACTERISTICS**

TEMP°F	TEMP°C	R-THERMISTOR (NOMINAL)	V-THERMISTOR (NOMINAL)
105	40.56	5.236KΩ	8.070V
106	41.11	5.123KΩ	8.012V
107	41.67	5.009KΩ	7.952V
108	42.22	4.901KΩ	7.893V
109	42.78	4.793KΩ	7.833V
110	43.33	4.690KΩ	7.773V
111	43.89	4.588KΩ	7.713V
112	44.44	4.489KΩ	7.653V
113	45.0	4.392KΩ	7.592V
114	45.56	4.297KΩ	7.531V
115	46.11	4.206KΩ	7.471V
120	48.89	3.779KΩ	7.165V
130	54.44	3.066KΩ	6.551V
140	60.00	2.503KΩ	5.944V
150	65.56	2.056KΩ	5.356V
160	71.11	1.698KΩ	4.797V
170	76.67	1.411KΩ	4.275V
180	82.22	1.178KΩ	3.792V
190	87.78	.989KΩ	3.353V
200	93.33	.834KΩ	2.957V
207	97.22	742.3Ω	2.706V
208	97.78	730.1Ω	2.671V
209	98.33	718.4Ω	2.638V
210	98.88	706.8Ω	2.604V
211	99.44	695.3Ω	2.571V
212	100.00	683.9Ω	2.538V
213	100.56	673.7Ω	2.508V
214	101.11	662.9Ω	2.476V
215	101.67	652.2Ω	2.444V
216	102.22	641.8Ω	2.413V
217	102.77	631.7Ω	2.383V

**J9-2** Phase "B" lower SCR cathode. See J9-1.

**J10-PINS**

**J10-1** Phase "C" upper SCR gate output. 1-3VAC as measured to J10-2.

**J10-2** Phase "C" upper SCR cathode. See J10-1.

**J11-PINS**

**J11-1** Phase "C" lower SCR gate output. 1-3VAC as measured to J11-2.

**J11-2** Phase "C" lower SCR cathode. See J11-1.

**J12-PINS**

**J12-1** Phase "A" AC power line input from 1T transformer (3Ø Delta). Measured to J12-4. See J1-6 for voltages.

**J12-2** Phase "B" AC power line input from 1T transformer (3Ø Delta). Measured to J12-4. See J1-6 for voltages.

**J12-3** Phase "C" AC power line input from 1T transformer (3Ø Delta). Measured to J12-4. See J1-6 for voltages.

**J12-4** GND.

**J13-PINS**

**J13-1** Switched 115VAC to cooling loop water pump motor, 115VAC when pump is commanded to run. 0VAC when commanded to stop. Measured to J5-2.

**J13-2** 115VAC as measured to J5-2.

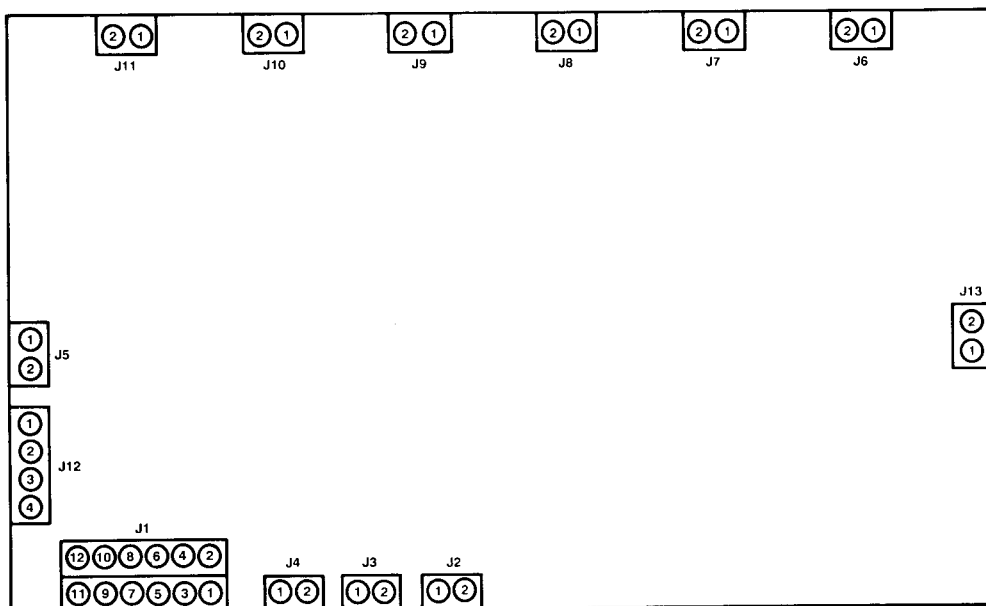

**FIG. 10 – TRIGGER BOARD PIN LOCATION DIAGRAM**

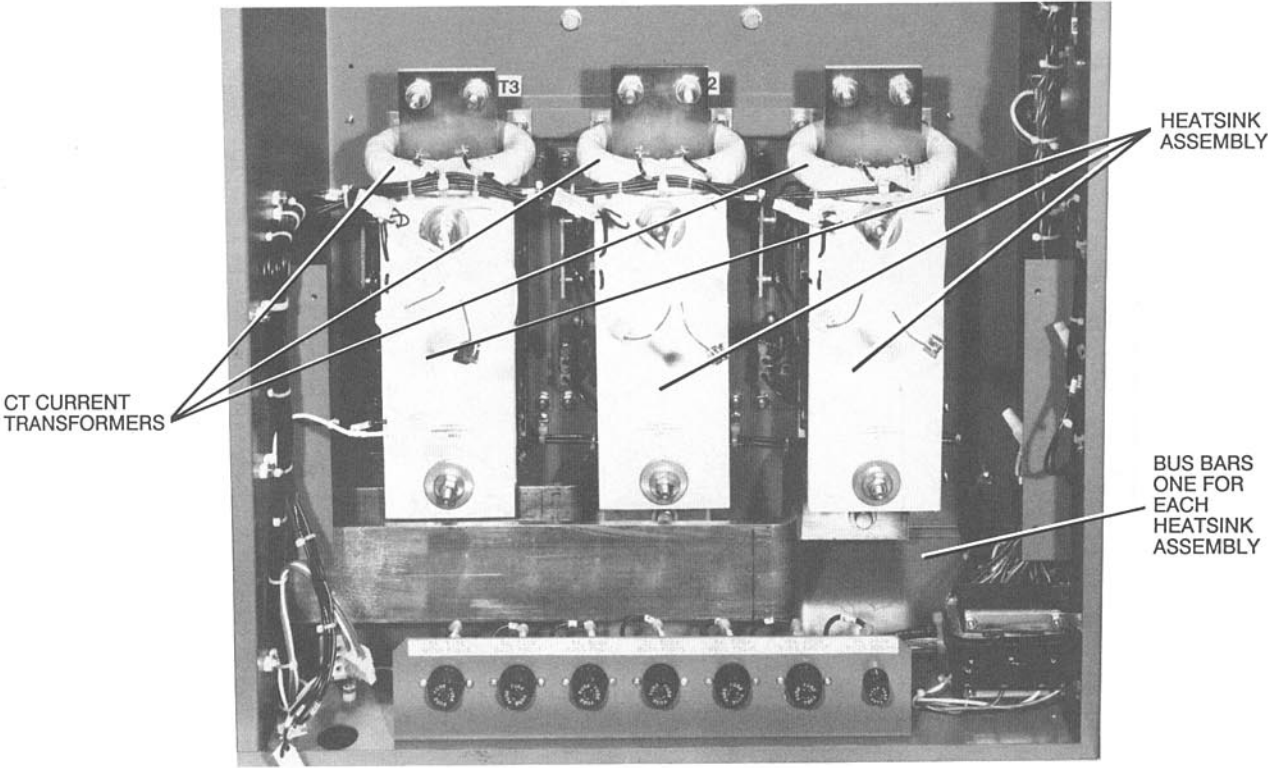

SECTION 5

FIG. 11 – SOLID STATE STARTER – WITH TRIGGER BOARD REMOVED SHOWING HEATSINKS

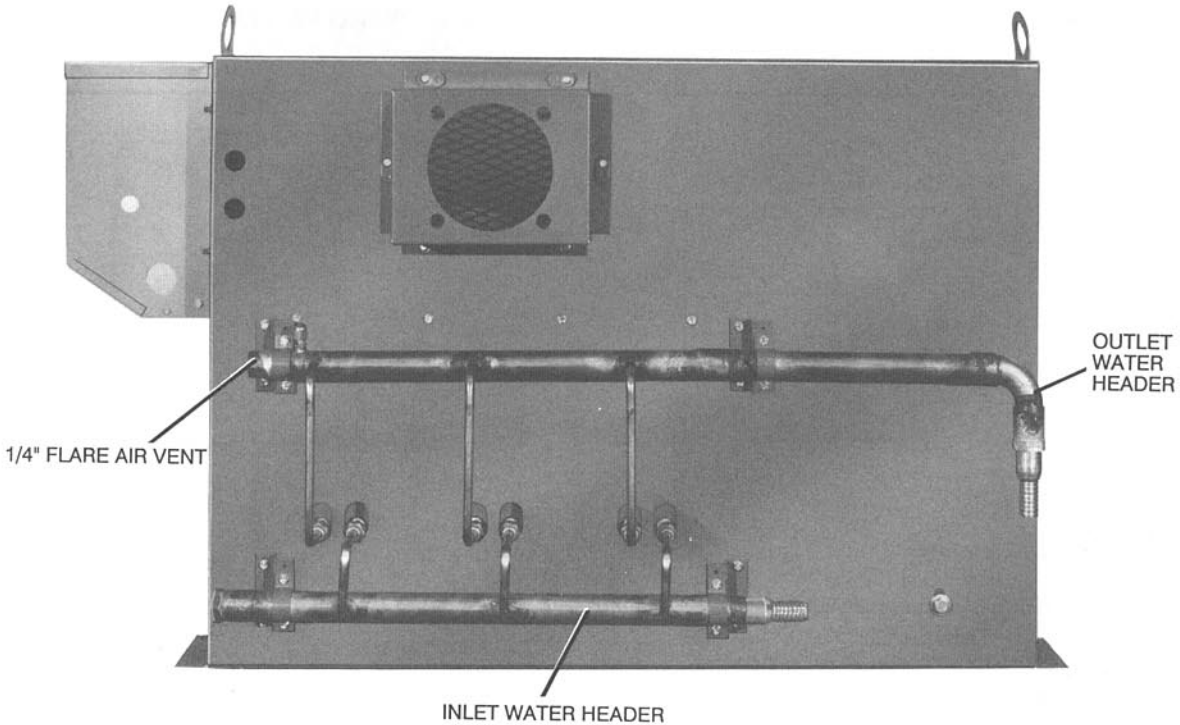

FIG. 12 – REAR VIEW OF SOLID STATE STARTER SHOWING WATER HEADERS  
YORK APPLIED SYSTEMS

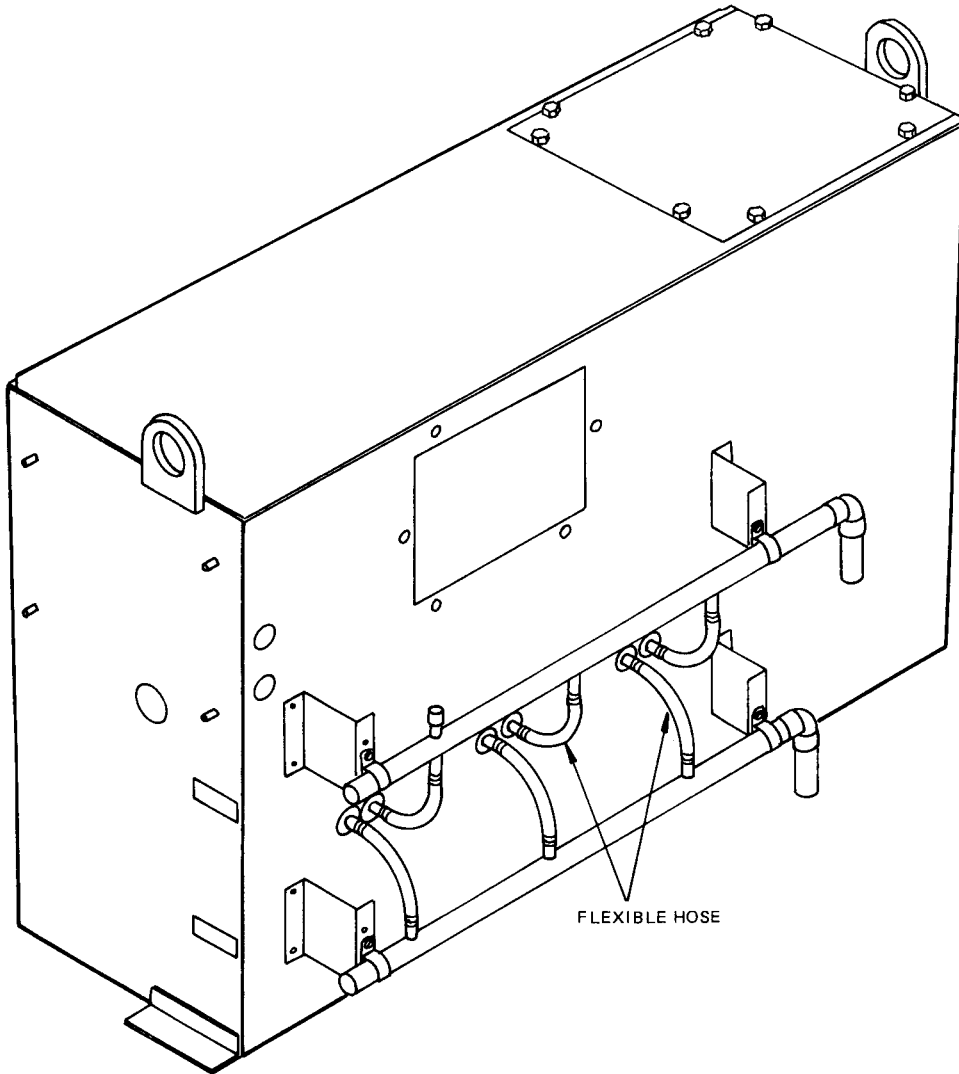

FIG. 12A – REAR VIEW OF STYLE “A” SOLID STATE STARTER SHOWING WATER HEADERS

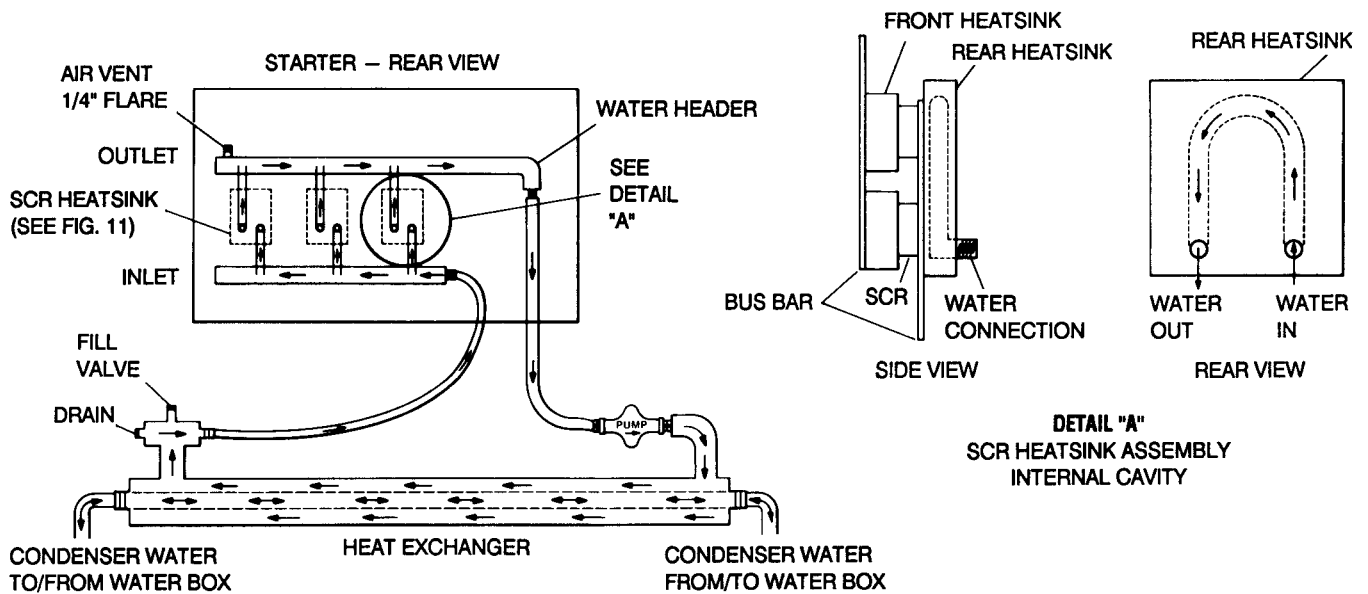

FIG. 13 – HEATSINK COOLING LOOP

## HEATSINK COOLING LOOP (Refer to FIG.'s 11, 12, 13 and 14)

The SCR heatsink assemblies are cooled with water circulating in a closed loop. Water is circulated through the rear heatsink of each SCR assembly where the water absorbs heat from the heatsink. The heated water then passes through the outer jacket of a heat exchanger and is then returned to the SCR heatsink assemblies. As the heated water passes through the outer jacket of the heat exchanger, it gives up its heat to system condenser water flowing through the center pipe of the heat exchanger. The closed loop heatsink water never mixes with system condenser water; it is isolated from condenser water by the heat exchanger. The closed loop water is circulated by a pump connected to the heat exchanger. However, condenser water is forced through the heat exchanger by the pressure differential of the condenser shell input and output.

The cooling loop is filled with water at system commissioning by the service technician. Refer to below.

### COOLING LOOP FILL INSTRUCTIONS: (Refer to FIG.'s 12, 13, 14)

The following procedure details the method of filling the cooling loop. Typically, the loop can be filled with ordinary tap water. However, if local water is highly mineralized, distilled water is preferred. All Style "A" starters and previous style starters equipped with Style "A" SCR assemblies (York P/N 371-01184/01185-XXX) must be filled with distilled water and corrosion inhibitor. Typically, the cooling loop water would never be changed. Exceptions would be if a cooling loop component is changed or those installations that require water evacuation over winter months due to freeze potential.

### REQUIRED MATERIAL:

ITEM	DESCRIPTION	QUANTITY
1	12" length of 1/4" copper tube bent in "U" shape with 1/4" flare nut on one end.	1 EA.
2	Garden hose, 5/8" diameter, cut to 5 ft. length with male garden hose connector on one end. Other end has no connector.*	1 EA.
3	Funnel, wide mouth	1 EA.
4	Bucket	1 EA.
5	Water jug.	1 EA.
6	Heat exchanger garden hose fill adapter (Shipped inside oil drip collection bottle).	1 EA.

(Continued)

\*A 5ft. length will be long enough to fill the smallest to the largest compressor.

ITEM	DESCRIPTION	QUANTITY
7	Corrosion inhibitor, AL/CU - (If required, see above). <u>New chillers</u> 1 oz. bottle provided inside oil drip collection bottle in MicroComputer Control Center. <u>SCR replacement assemblies</u> - 1 oz. bottle supplied with replacement kit (375-03048-XXX).	1 EA.
8	Distilled water (if required, see above).	1/2 GAL.

### FILL PROCEDURE:

1. Assemble the material listed above.
  2. Remove the cap from the air vent located on the upper water header.
  3. Install air vent assembly (Item 1) to air vent. Position to allow water to drain into bucket (Item 4).
  4. Position bucket (Item 4) under air vent assembly to catch water.
  5. Connect heat exchanger garden hose fill adapter (Item 6) to heat exchanger. Connect garden hose (Item 2) to fill adapter. (Item 6).
  6. The service technician should be in position to hold the hose in an upright position so the top of the hose is above the upper (outlet) water header.
  7. Insert the funnel (Item 3) into the top end of the hose.
  8. Style "A" starters and those starters equipped with Style "A" replacement SCR assemblies (P/N 371-01184/01185-XXX):
    - a. Pour approximately 2 pints distilled water (Item 8) from jug (Item 5) into funnel (Item 3) to begin filling cooling loop.
    - b. Mix approximately 1 pint distilled water with corrosion inhibitor (Item 7) in jug and pour solution into funnel.
    - c. Proceed to Step 9.
- All others:
- a. Pour water (distilled or tap - see above) from jug (Item 5) into funnel (Item 3) to fill cooling loop.
  - b. Proceed to Step 9.

SECTION  
5

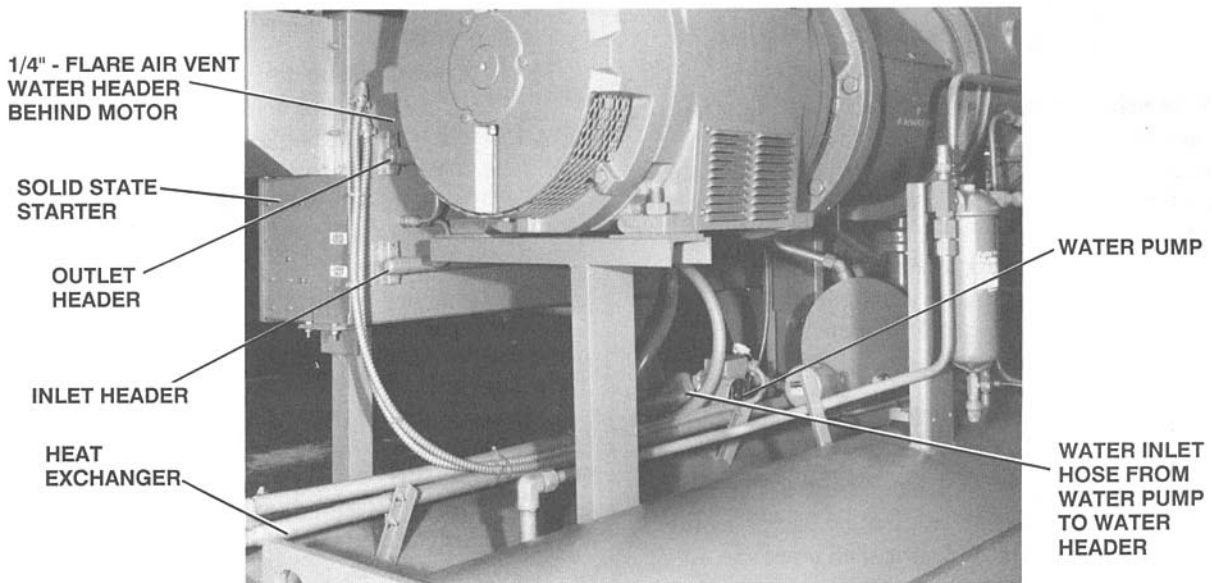

FIG. 14 – LOCATION OF HEATSINK COOLING COMPONENTS

9. Continue filling cooling loop until water begins to flow from air vent removing as much air as possible. If corrosion inhibitor has been added, try to keep loss to a minimum.
10. Lower funnel to level of upper water header to stop water from flowing from air vent.
11. Immediately remove air vent assembly (Item 1) and cap air vent.
12. Remove hose from heat exchanger fill valve and empty residual water from hose into bucket.
13. Run cooling loop pump for 5 minutes by removing connector P2 from J2 on Trigger Board. When 5 minutes have elapsed, stop pump by connecting P2 to J2 on Trigger Board.
14. Repeat steps 1 through 12 to assure that the cooling loop is completely filled with water and all air has been evacuated.
15. Check all water connections for leaks.

#### DRAIN PROCEDURE

Remove drain plug and allow water to drain into bucket.

## SECTION 6 SYSTEM CALIBRATION

Due to the integration of the starter Logic Board into the MicroComputer Control Center, the system calibration in-

structions are included in the MicroComputer Control Center Service Instruction referenced on Page 2.

## SECTION 7 START-UP CHECKLIST

- **IMPORTANT!!!** - Remove all debris from left-hand compartment of starter cabinet where AC powerline cables attach to starter bus bars. This includes nuts, bolts, washers, hand tools, test equipment, etc. Motor starting current creates strong magnetic fields that can pull metal objects into the starter bus bars possibly causing short circuits and damaging the Solid State Starter!!
- Fill SCR heatsink assembly cooling loop with water per instructions on page 19.
- Verify correct position of 300V/600V AC powerline application jumper on starter Logic Board. On 200/208V AC and 220/230/240V AC applications the jumper must be in the 300V position. On 440/460/480V AC, 380/400/415V AC and 550/575/600V AC applications

550/575/600VAC applications the jumper must be in the 600V position.

- On the MicroComputer Control Center, verify the following have been properly entered: (Refer to MicroComputer Control Center Service Instruction referenced on Page 2).
  - a) Chiller full load amps setpoint.
  - b) Supply voltage range setpoint.

- Verify calibration of Logic Board **start current** and **overload current**. (Refer to Calibration Instructions in MicroComputer Control Center Service Instruction referenced on Page 2.
- Verify that jumper J7 has been removed from starter Logic Board.

## SECTION 8 TROUBLESHOOTING

The following procedures are designed to guide the service technician along the path that leads to the identification of the cause of the problem. The service technician should understand the operation of the Liquid Cooled Solid State Starter and function of each major component and PC board. It is recommended that the service technician read and understand the information contained in this instruction prior to troubleshooting this product. Also, the service technician must understand the system interface, and be able to utilize system wiring diagrams to follow signal flow throughout the system. Due to the integration of the Liquid Cooled Solid State Starter with the MicroComputer Control Center, a knowledge of the MicroComputer Control Center is also necessary (Ref. Form listed on Page 2).

Several levels of documentation are required for the troubleshooting process. The Liquid Cooled Solid State Starter wiring diagram, supplied with every starter is the top level document. It provides the overall wiring and configuration. Sections of this instruction provide the required lower levels, Specifically, block diagrams provide signal flow and simplified representations of PC board circuitry. The "Inputs and Outputs" of each board provide details of the required voltage levels at all connectors on the PC boards.

The following are the major categories of problems included in the troubleshooting procedures:

- Starting Problem.
- Overload (while running).
- Overload (while starting).
- Power Fault.
- OOL.
- ØROT/LOSS.
- High Temp.
- Cooling Loop and Water Pump.
- Motor Current Display.
- AC Power Line Voltage Display.
- Half Phase.

Begin the troubleshooting process by selecting the appropriate procedure. It is not necessary to sequentially

perform all of them. Perform a procedure only if there is a problem with that function.

### REPLACING AN SCR ASSEMBLY

If it becomes necessary to replace an SCR, the entire SCR heatsink assembly must be replaced. SCR's are not individually replaceable.

Early vintage starters (7L, 14L, 26L, 33L, - P/N 371-01071/01072-XXX) were supplied with SCR assemblies P/N 371-01085-XXX or 371-01106-XXX.

Style "A" starters (7L-A, 14L-A, 26L-A, 33L-A - P/N 371-01210-01211-XXX) and (26LK-A, 33LK-A - P/N 371-01237-XXX) are supplied with SCR assemblies P/N 371-01184-XXX or 371-01185-XXX. For service replacement purposes, these SCR assemblies are supplied as part of a kit (P/N 375-03048-XXX) (Ref. 160.46-RP1 (Sect. 4) that contains the necessary ancillary items used in SCR assembly replacement. These kits also contain items that allow the Style "A" SCR assemblies to be installed in the early vintage starters. (7L, 14L, 26L, 33L - P/N 371-01071-01072-XXX). The Style "A" SCR assemblies will eventually replace early vintage SCR assemblies for service replacement purposes.

Refer to Replacement Parts List Form 160.46-RP1 (Sect.4) for replacement SCR assembly kit part numbers.

### INSTALLING SCR ASSEMBLIES (371-01085-XXX or 371-01106-XXX) IN EARLY VINTAGE STARTERS (371-01071-XXX or 371-01072-XXX). (7L, 14L, 26L, 33L):

1. Remove AC power from system.
2. Drain water from cooling loop.
3. Loosen both water header connections to the defective heatsink assembly.
4. Remove all connections to Trigger Board. Remove Trigger Board assembly by removing 4 panel mounting screws.

SECTION

6

SECTION

7

SECTION

8

5. Remove all electrical connections.
6. Remove current transformer from mounting studs and fold out of the way. Remove electrical connections if necessary.
7. Remove the four SCR/heatsink assembly mounting nuts from the mounting studs and remove the entire SCR/Heatsink assembly.
8. Place the defective assembly on a work surface and remove the capacitor assembly, resistor assembly and water connections (2).
9. Install the parts removed in step #8 to the new assembly. Refer to Fig.'s 15, 16 and 17.
10. Install the new SCR/heatsink assembly in the starter and install the water and electrical connections.
11. Install Current Transformer, Trigger Board and make all necessary electrical connections.
12. Fill cooling loop with water per COOLING LOOP FILL INSTRUCTIONS in Section 5.

In the following procedures, item numbers refer to items supplied in SCR assembly replacement kits as detailed in Table 2. Refer to YORK Form 160.46-RP1 (Sect. 4) for SCR assembly replacement kit numbers. Do not order individual parts. Order kits only.

**TABLE 2 — STYLE "A" SCR ASSEMBLY REPLACEMENT KITS 375-03048-XXX**

		KIT REPLACEMENT SCR							
		SSS7L-46,50		SSS7L-58		SSS14L-17,28,46,50		SSS14L-58	
		375-03048-002		375-03048-003		375-03048-004		375-03048-005	
DESCRIPTION	ITEM	PART NO.	QTY	PART NO.	QTY	PART NO.	QTY	PART NO.	QTY
Common Parts	20	375-03048-001	1	375-03048-001	1	375-03048-001	1	375-03048-001	1
Rectifier Assy.	21	371-01184-332	1	371-01184-333	1	371-01184-334	1	371-01184-335	1
Standoff	22	—	—	—	—	—	—	—	—

		KIT REPLACEMENT SCR							
		SSS26L-17, 28,46,50 & SSS26LK-46,50			SSS26L-58 & SSS26LK-58		SSS33L-17,28,46,50 & SSS33LK-46,50		
		375-03048-006			375-03048-007		375-03048-005		
DESCRIPTION	ITEM	PART NO.	QTY	PART NO.	QTY	PART NO.	QTY	PART NO.	QTY
Common Parts	1	375-03048-001	1	375-03048-001	1	375-03048-001	1	375-03048-001	1
Rectifier Assy.	1	371-01185-332	1	371-01185-333	1	371-01186-332	1	371-01186-332	1
Standoff	2	021-17565-000	2	021-17565-000	2	021-17565-000	2	021-17565-000	2

PART NO.	ITEM	Quantity Per Unit	DESCRIPTION
075-03048-000	1	1	INSTRUCTION, INSTALLATION
013-02879-000	2	1	INHIBITOR, CORROSION AL/CU
021-17547-000	3	4	CLAMP, HOSE CLUTCH TYPE
023-16247-000	4	2	FITTING, STR. 3/8 I.D. HOSE
028-12239-000	5	1.5 ft.	TUBE, PLASTIC 3/8 I.D.
023-16260-000	6	2	NIPPLE, BRASS 1/4 NPT X 7/8
023-00900-000	7	2	FITTING, 1/4 INT. X 3/8 EXT. FL.
013-02880-000	8	1	COMPOUND, ANTI-OXIDANT
030-00755-000	9	1	BAG, CLOTH W/DRAWSTRING

375-03048-001

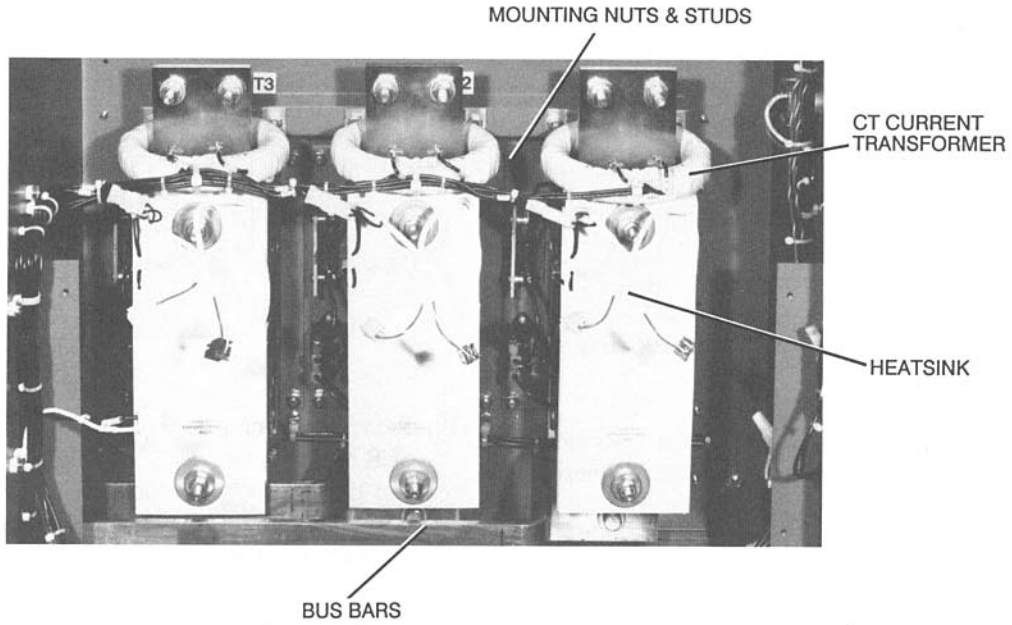

FIG. 15 – REMOVING HEATSINK ASSEMBLY

SECTION  
8

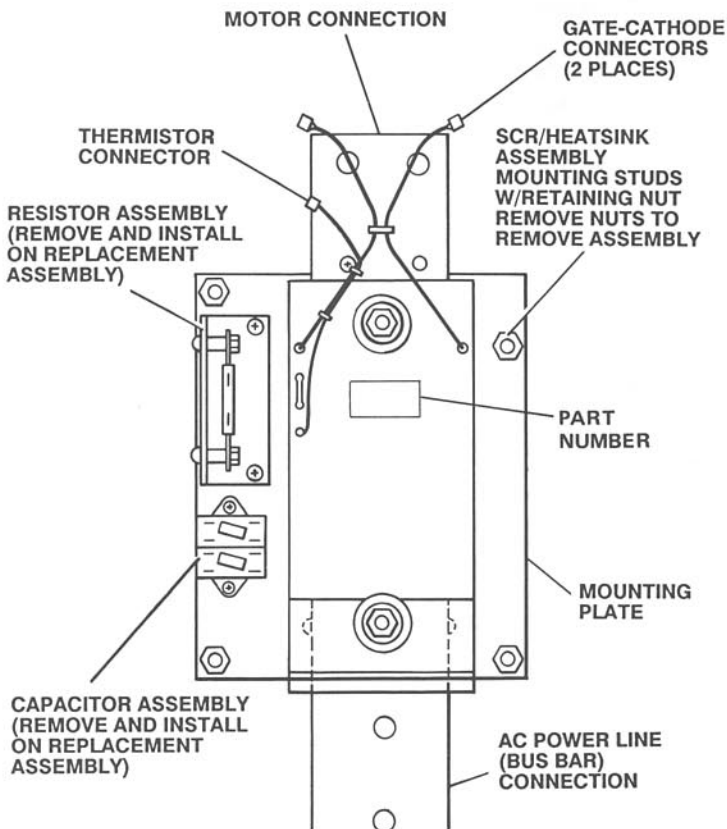

FIG. 16 – ILLUSTRATION OF SCR/HEATSINK ASSEMBLY

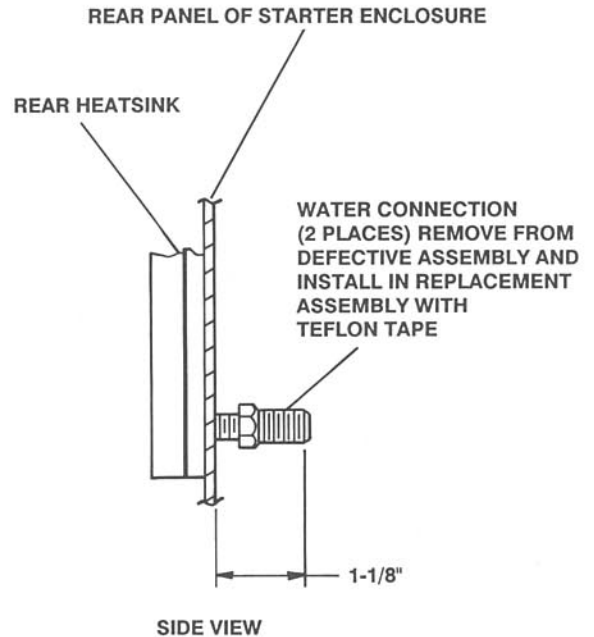
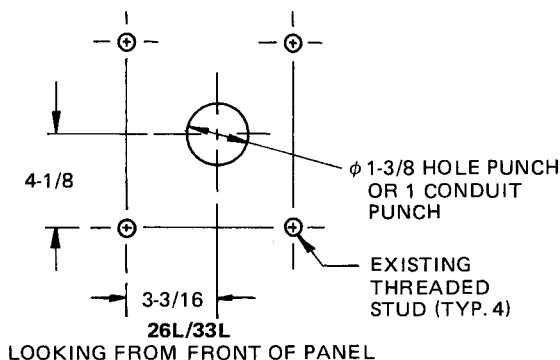
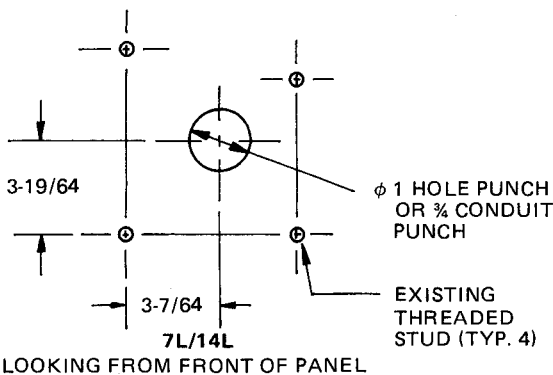

FIG. 17 – HEATSINK WATER CONNECTIONS

**INSTALLING STYLE "A" SCR ASSEMBLIES (371-01184-XXX or 371-01185-XXX) IN EARLY VINTAGE STARTERS (371-01071-XXX or 371-01072-XXX) (7L, 14L, 26L, 33L):**

**NOTE:** When installing in early vintage 7L starter, use 14L SCR assembly (kit P/N 375-03048-004 or -005). Style "A" 7L SCR assembly will not fit in early vintage 7L starter.

1. Remove AC power from system.
2. Drain water from cooling loop.
3. Loosen both water header connections to the defective heatsink assembly.
4. Remove all connections to Trigger Board. Remove Trigger Board assembly by removing 4 panel mounting screws.
5. Remove all electrical connections.
6. Remove current transformer from mounting studs and fold out of the way. Remove electrical connections if necessary.
7. Remove the four SCR/heatsink assembly mounting nuts from the mounting studs and remove the entire SCR/Heatsink assembly.
8. Refer to Fig. below. Using a hole or conduit punch (Greenlee), punch a hole in the rear panel of the starter to allow the SCR bolt head to protrude thru. Remove any metal filings from enclosure before proceeding.



9. Assemble Item 6 to Item 7 using Loctite. Make two assemblies. Install these assemblies into the new SCR assembly per figure below. Use teflon tape on nipple threads which thread into heatsink.

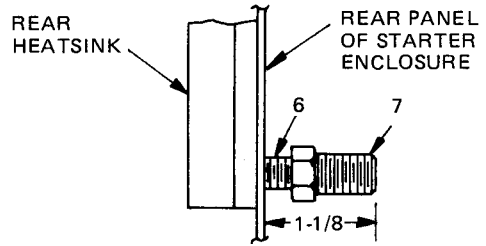

**SIDE VIEW**  
HEATSINK WATER CONNECTION

10. Remove resistor and capacitor assembly from defective SCR assembly and install on new assembly per Fig. 18 and 19, using only one lock washer under each mounting screw. Note connection of resistor and capacitor assembly to SCR assembly.
11. If installing in model 26L or 33L starter, remove the current transformer from the bracket of the phase being replaced. Screw the standoffs (Item 22) onto the existing current transformer bracket studs and install the current transformer onto the standoffs. This allows the SCR assembly motor connection bus bar to properly pass through the CT.
12. Install replacement SCR assembly in starter cabinet. Make all water and electrical connections. On 7L and 14L models, the replacement SCR assembly bus bar is aluminum. The mating surfaces of the SCR assembly and input bus bar must be cleaned with fine emery paper or Scotchbrite® pad and coated with a thin film of joint compound (Item 8) before joining (this prevents corrosion between the copper and aluminum bus bars). Torque bolts to 16-20 ft.-lbs.
13. Fill cooling loop with distilled water. Add corrosion inhibitor (Item 2). Refer to cooling loop fill instructions in Section 5.
14. Kit Items 3, 4 and 5 are not used.

**INSTALLING STYLE "A" SCR ASSEMBLIES (371-01184-XXX or 371-01185-XXX) IN STYLE "A" STARTERS (371-01210-XXX or 371-01211-XXX). (7L-A, 14L-A, 26L-A, 33L-A) AND (371-01237-XXX) (26LK-A, 33LK-A):**

1. Remove AC power from system.
2. Drain water from cooling loop.
3. Loosen both water header connections to the defective heatsink assembly.

4. Remove all connections to Trigger Board. Remove Trigger Board assembly by removing 4 panel mounting screws.
5. Remove all electrical connections.
6. Remove current transformer from mounting studs and fold out of the way. Remove electrical connections if necessary.
7. Remove the four SCR/heatsink assembly mounting nuts from the mounting studs and remove the entire SCR/Heatsink assembly.
8. Remove resistor and capacitor assembly from defective SCR assembly and install on replacement SCR assembly. Refer to Fig. 18 & 19.
9. Install hose fitting (Item 4) in SCR assembly. Use teflon tape on threads.

10. Install SCR assembly in starter. Make all electrical connections. On 7L and 14L models, it is necessary to clean the mating surfaces of the SCR assembly and input bus bar with fine emery cloth or Scotchbrite® pad and coat with a thin film of joint compound (Item 8) before attaching the input bus bar. Torque bolts to 16-20 ft.-lbs.
11. Using hose (Item 5), fabricate water header connections to SCR assembly. Cut to required length (tubing must not be kinked). Secure hose with clamps (Item 3).
12. Fill cooling loop with distilled water. Add corrosion inhibitor (Item 2). Refer to cooling loop fill instructions in Section 5.
13. Kit Items 6 and 7 are not used.

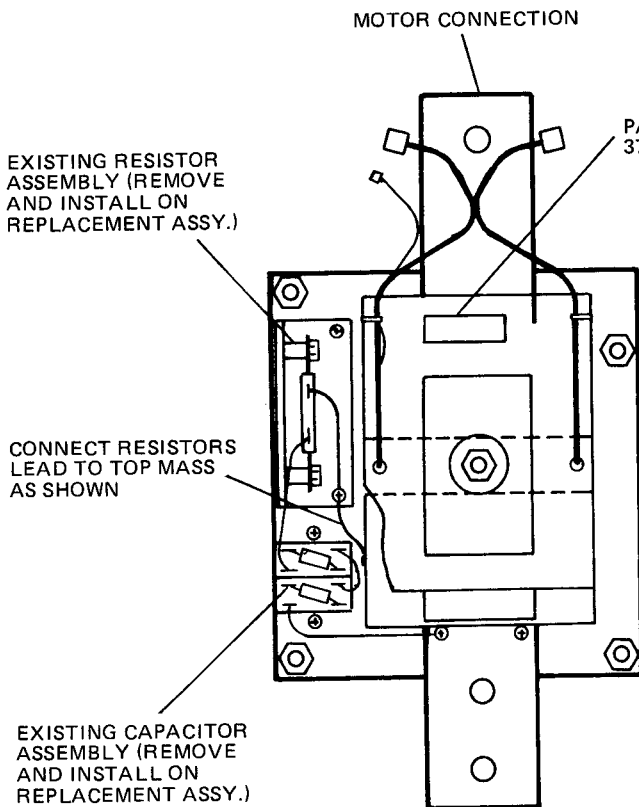

FIG. 18 — 7L / 14L

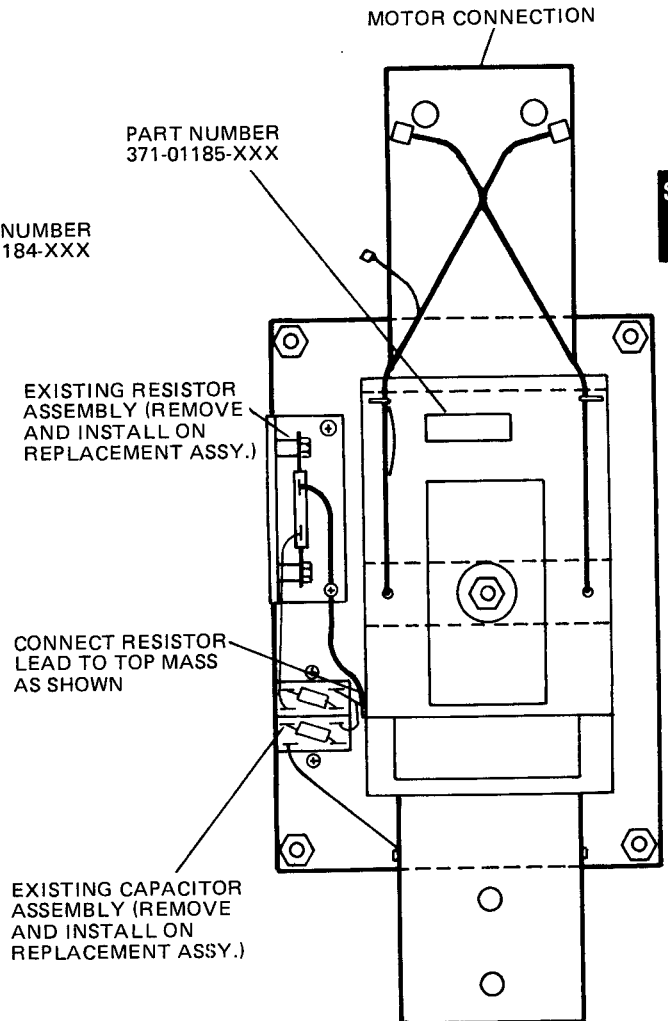
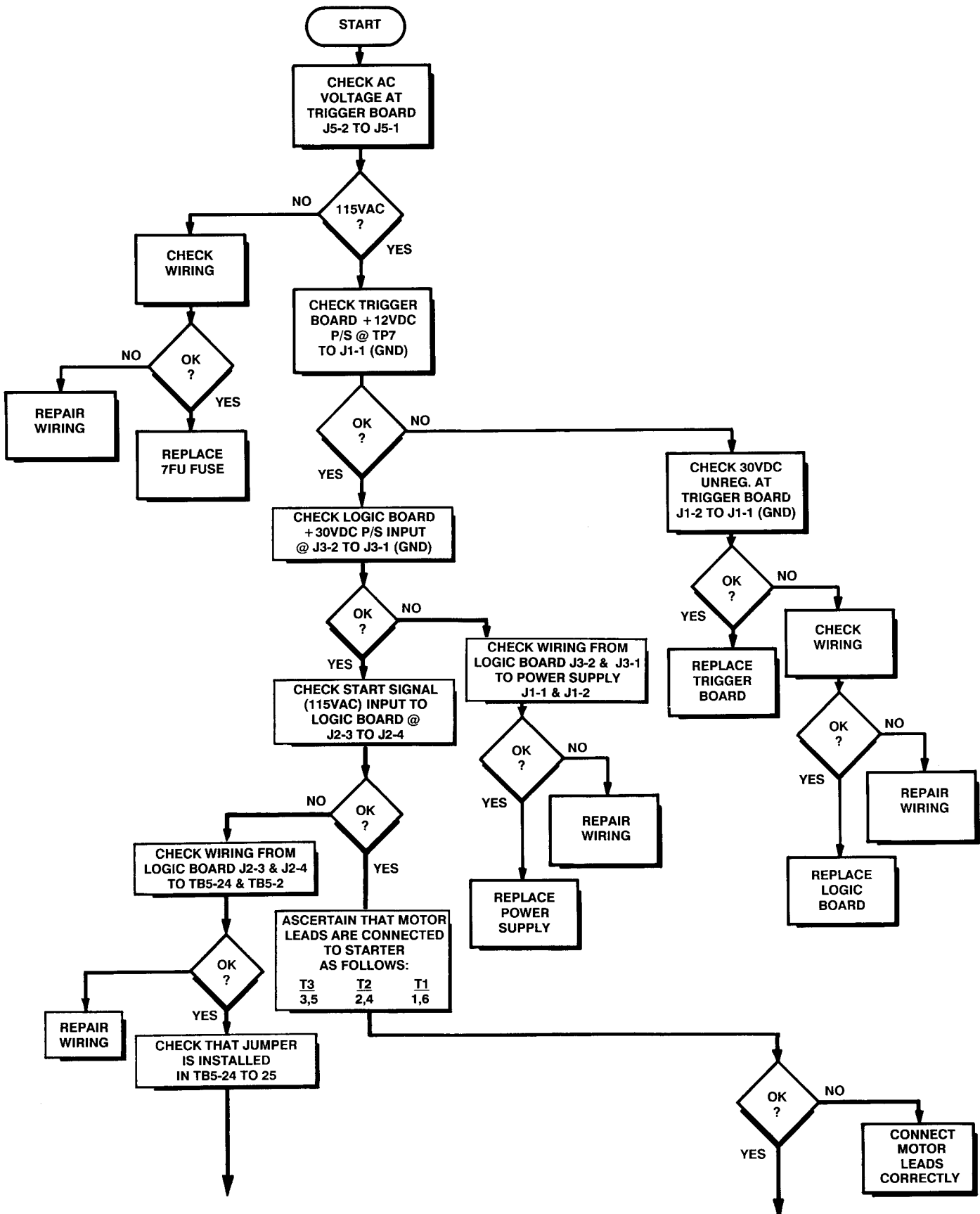

FIG. 19 — 26L / 33L

SECTION 8

# TROUBLESHOOTING STARTING PROBLEM



(Continued on Page 27)

# TROUBLESHOOTING STARTING PROBLEM

(Con't From Page 26)

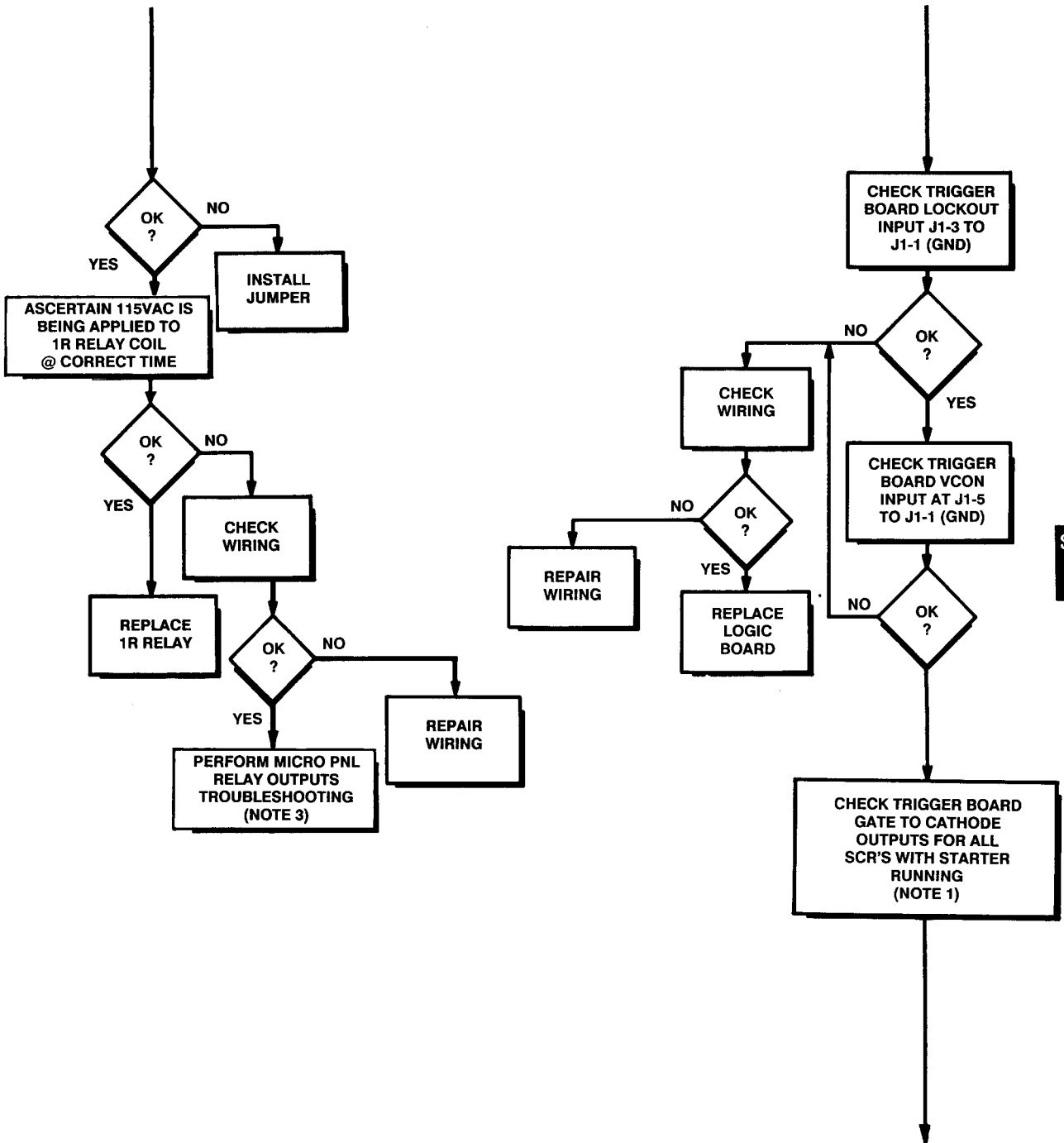

SECTION  
8

(Con't on Page 28)

# TROUBLESHOOTING STARTING PROBLEM

(Con't From Page 27)

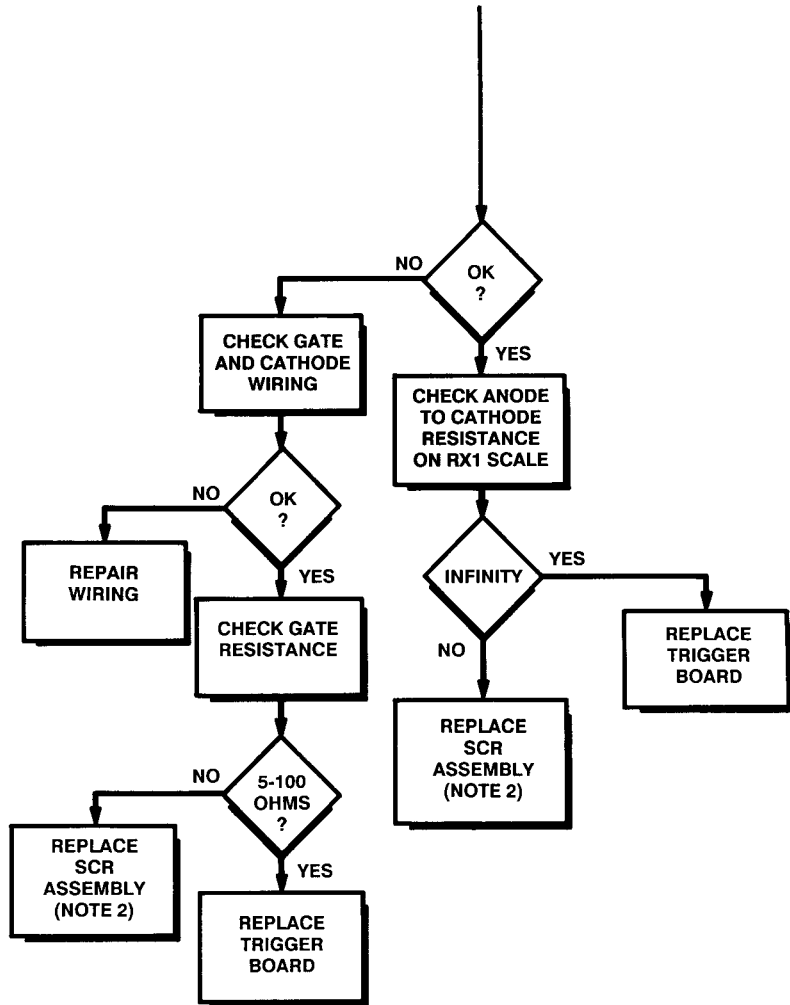

**NOTES:**

1. Remove motor wiring prior to check. Starter will only run 4-7 seconds. Use multiple starts to complete test.
2. Individual SCR's are not field replaceable. Replace the assembly.
3. Refer to appropriate MicroComputer Control Center service manual as follows:
  - Model YT "E" Style Centrifugal - 160.46-M2
  - Model YT "F" Style Centrifugal - 160.48-M2
  - Screw Chiller - 160.47-M2
  - Model YK "A" Style Centrifugal - 160.49-M2

# TROUBLESHOOTING OVERLOAD (WHILE RUNNING)

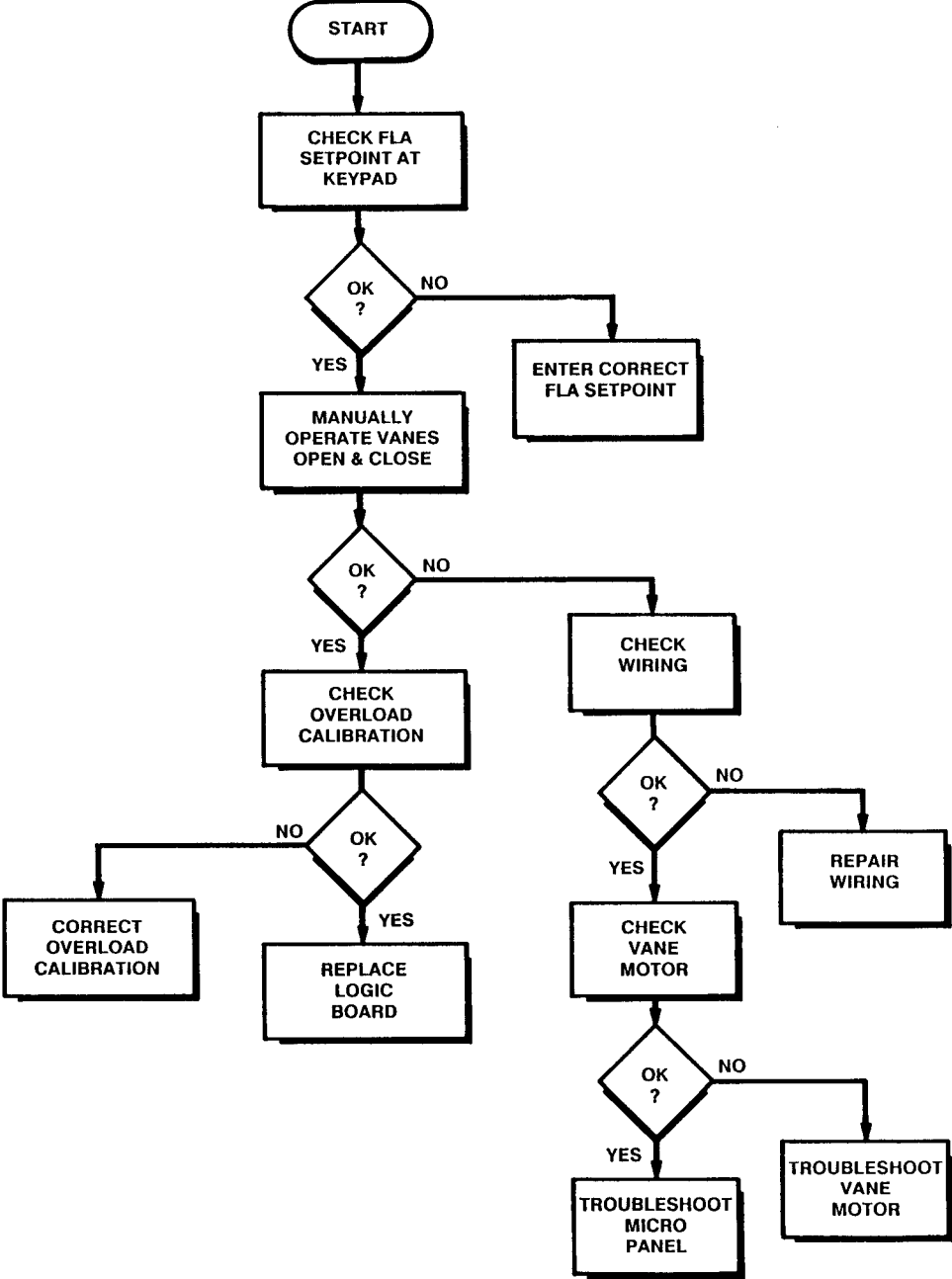

SECTION  
8

# TROUBLESHOOTING

## OVERLOAD (WHILE STARTING)

## POWER FAULT

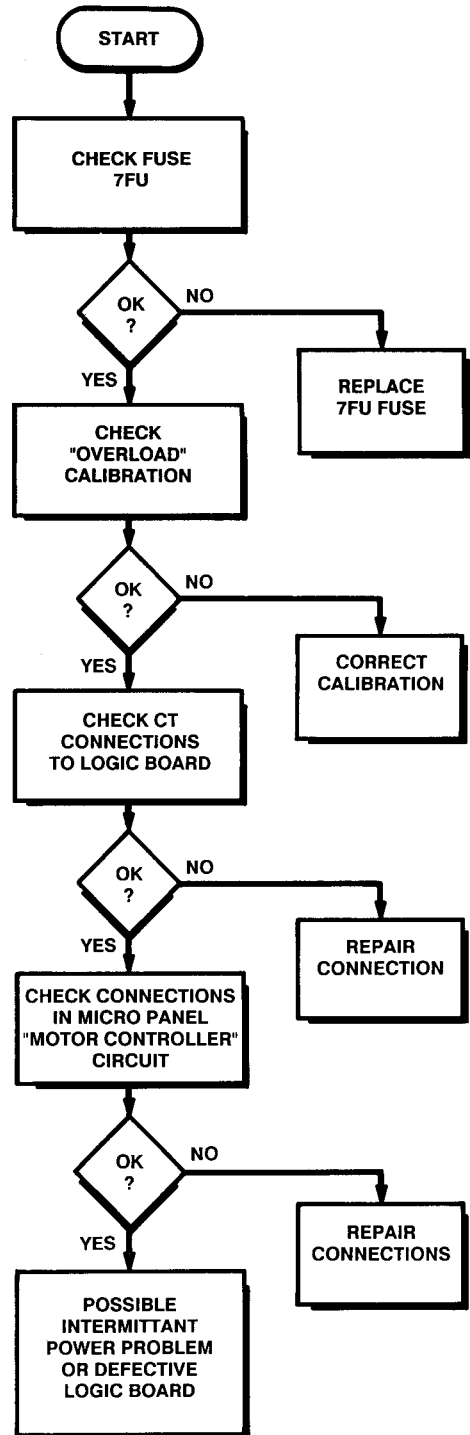
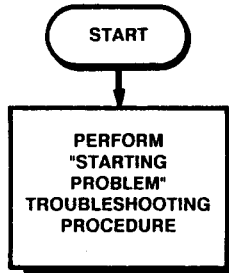

# TROUBLESHOOTING OOL

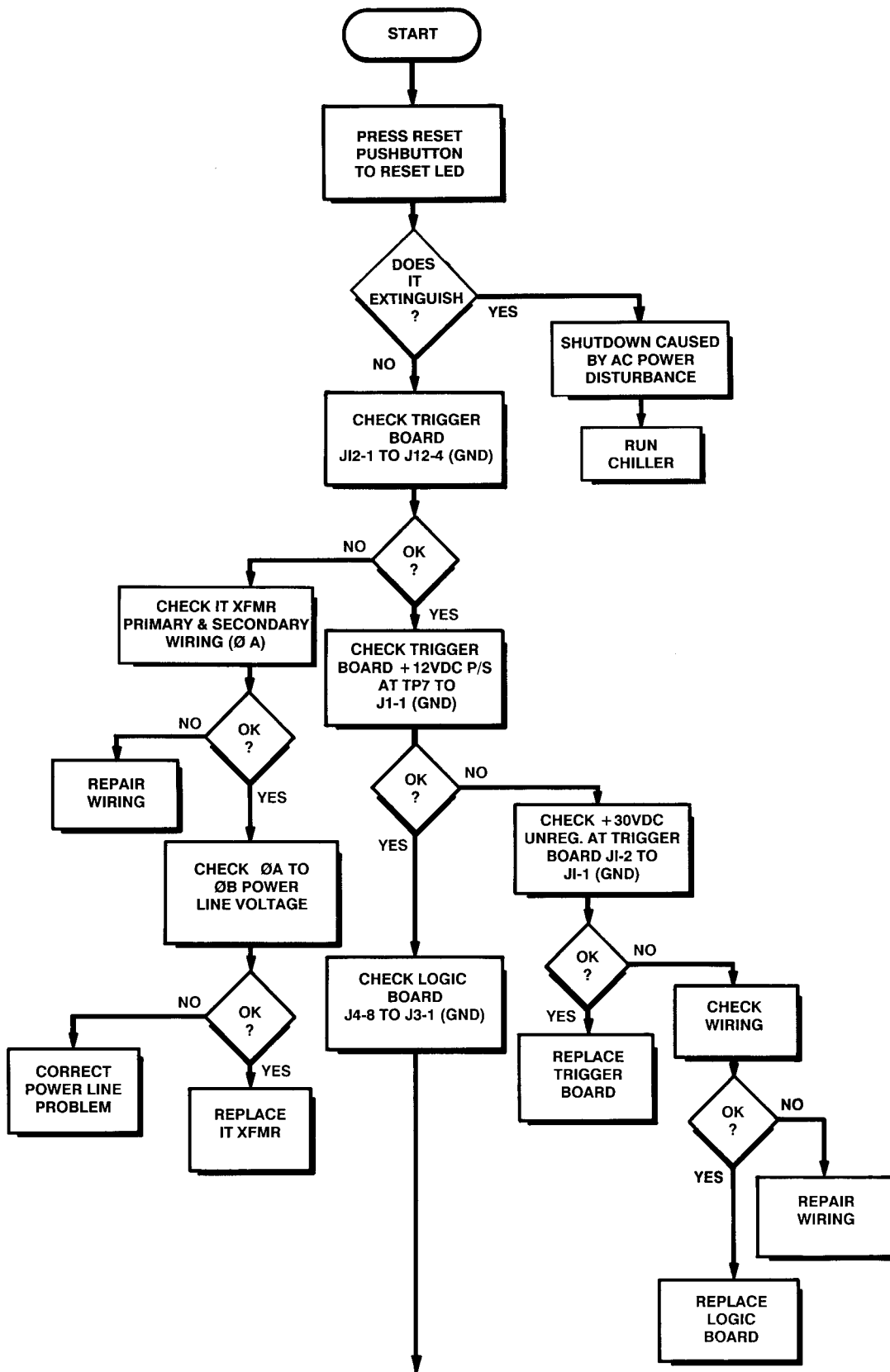

(Con't on Page 32)

# TROUBLESHOOTING OOL

(Con't From Page 31)

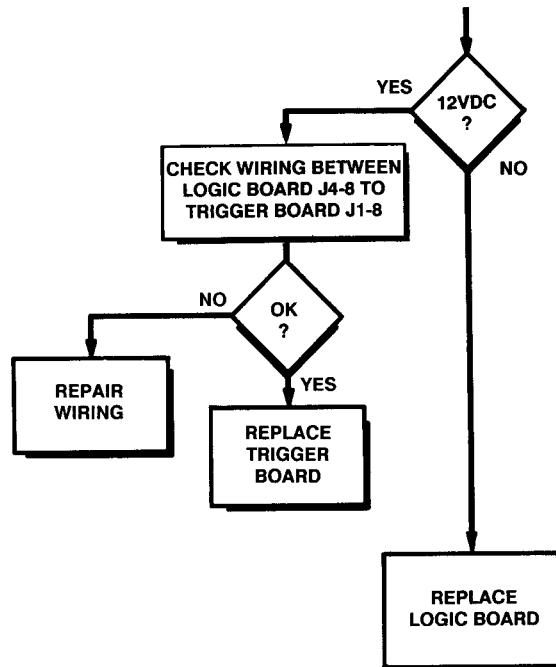

# TROUBLESHOOTING Ø ROT / LOSS

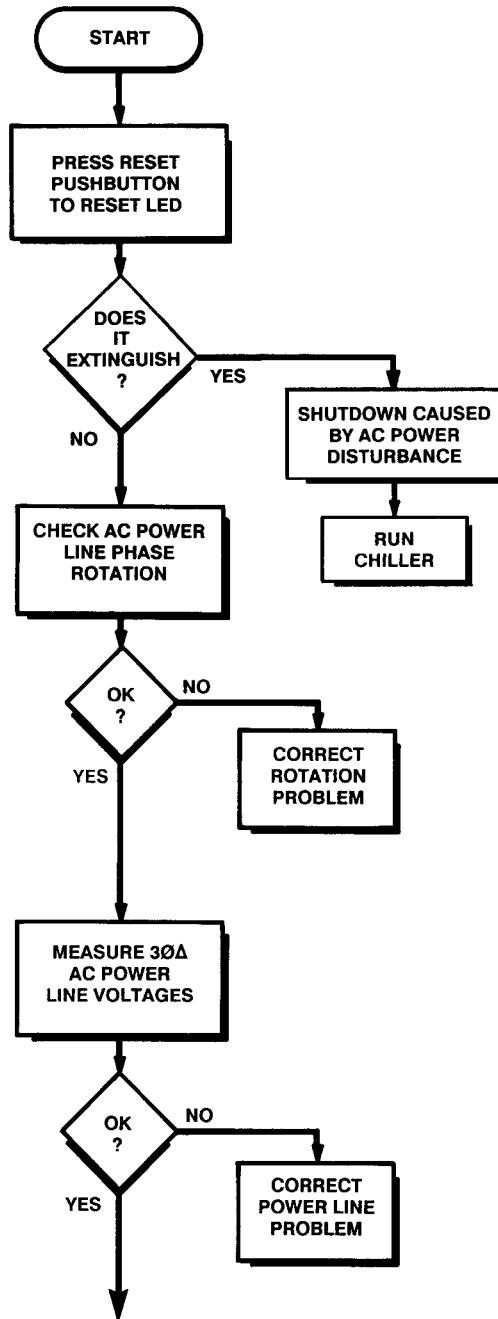

SECTION  
**8**

(Con't on Page 34)

# TROUBLESHOOTING HIGH TEMP

**NOTE:**

1. If starter is operating in high ambient temperatures, it is normal for the HIGH TEMP LED to be illuminated for a few minutes after system is shut-down. The cooling loop water pump will run during this period to cool the SCR heatsink assemblies to below 110°F. If HIGH TEMP LED remains illuminated, proceed with this procedure.

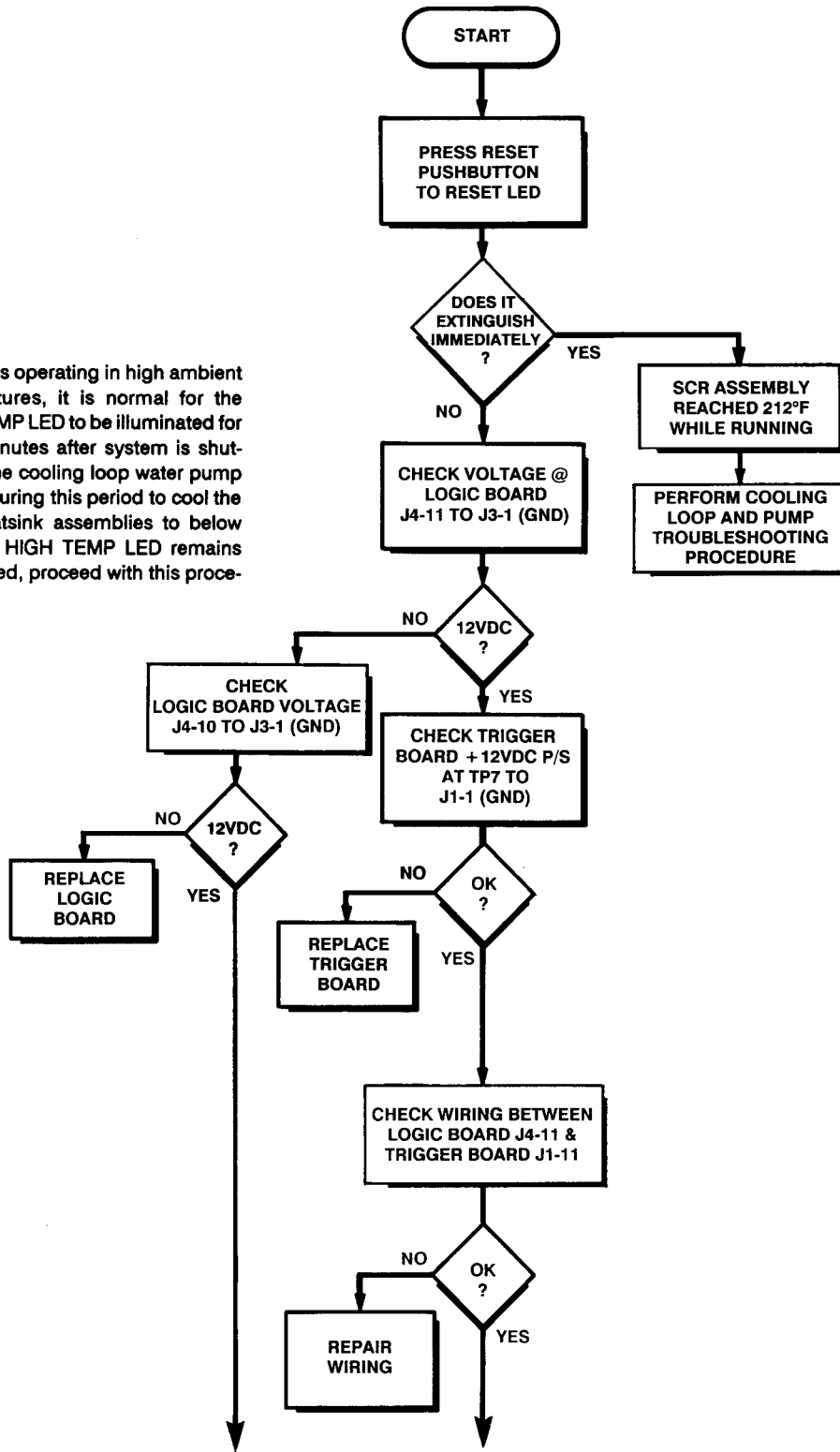

(Con't on Page 36)

# TROUBLESHOOTING HIGH TEMP

(Con't From Page 35)

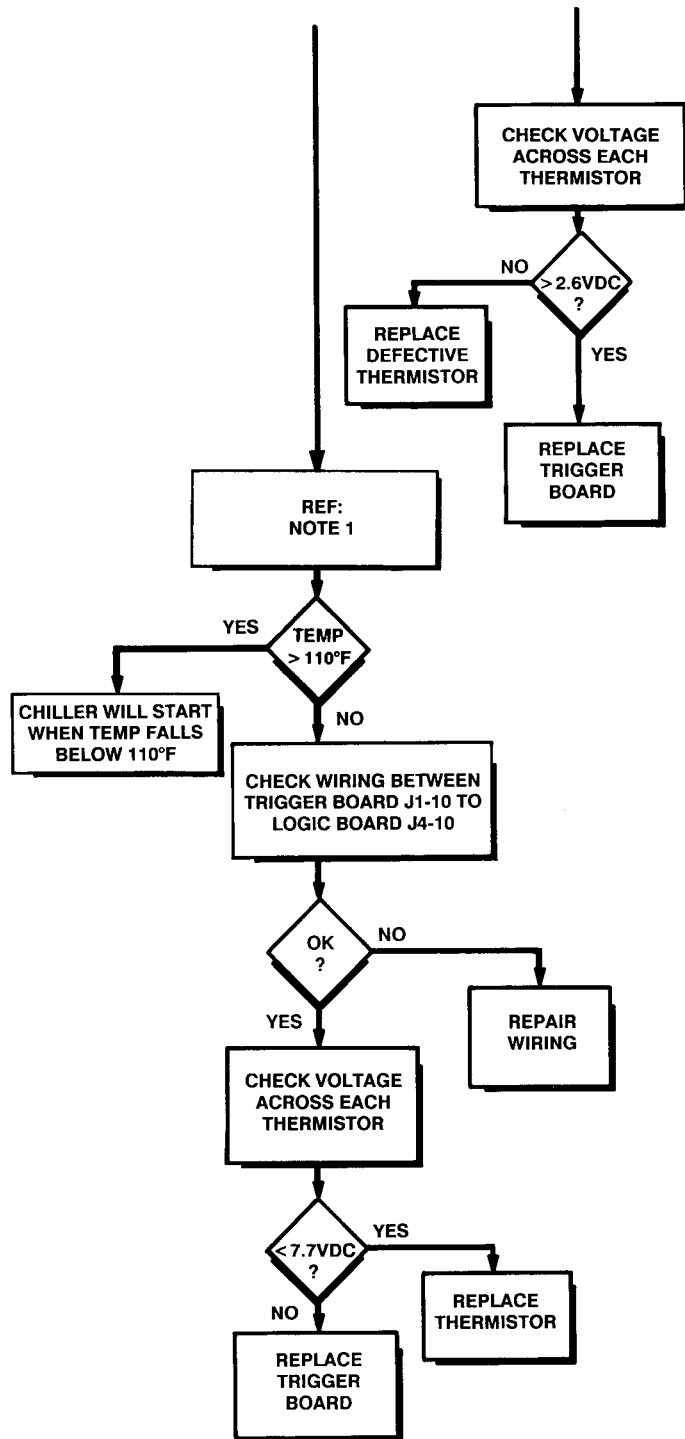

## TROUBLESHOOTING COOLING LOOP & WATER PUMP

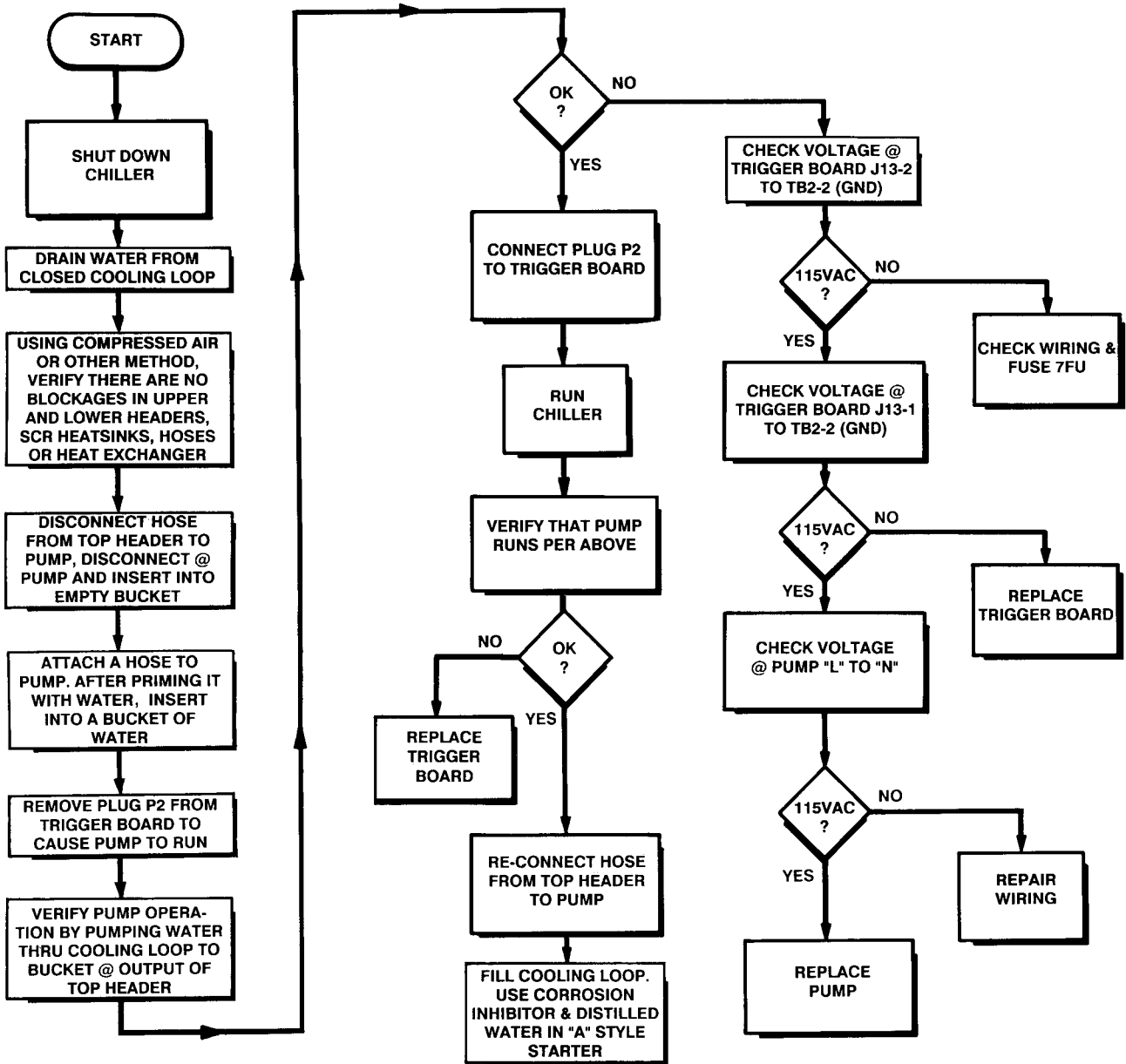

SECTION  
**8**

# TROUBLESHOOTING MOTOR CURRENT DISPLAY

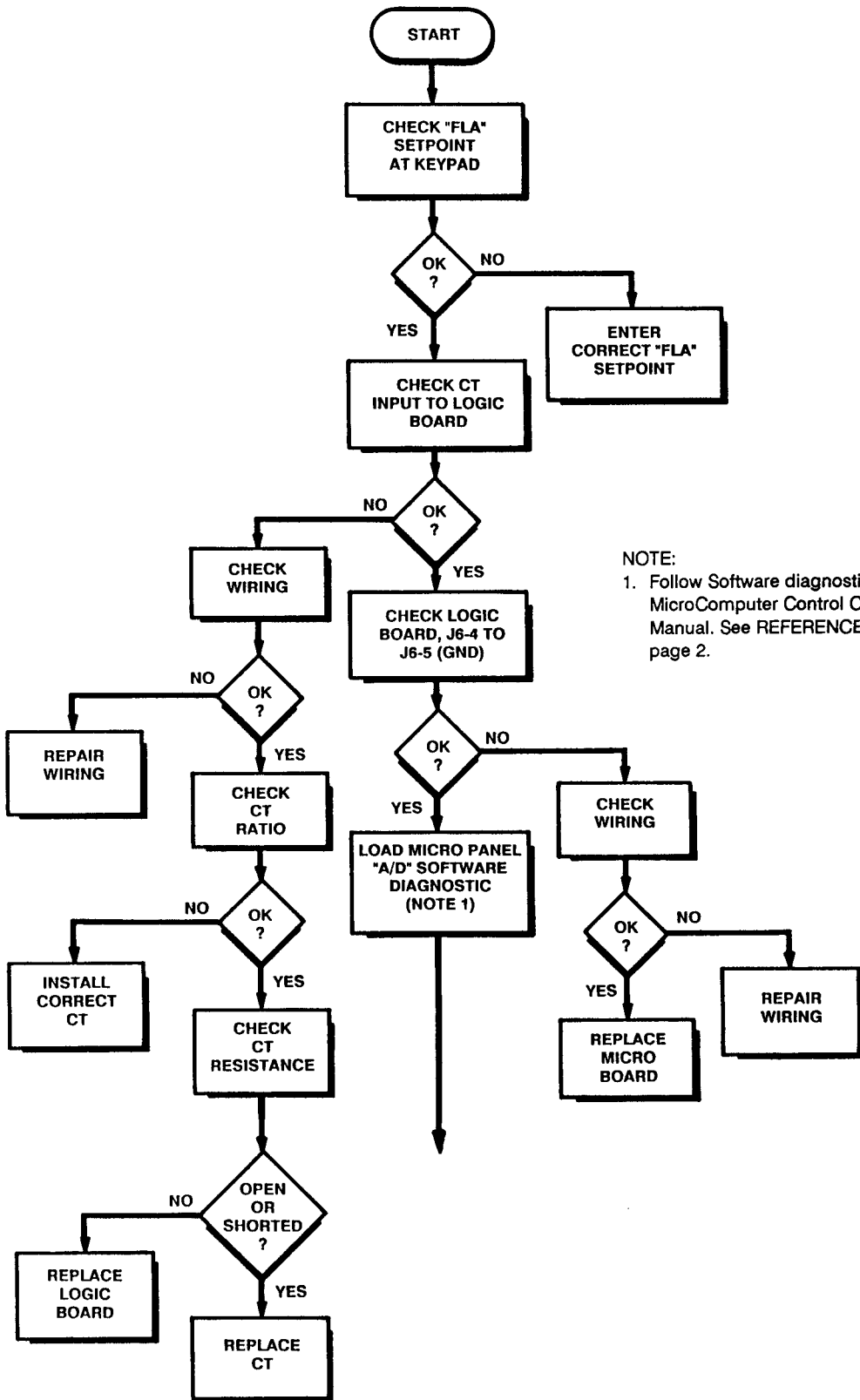

NOTE:  
1. Follow Software diagnostic instructions in MicroComputer Control Center Service Manual. See REFERENCE INSTRUCTIONS, page 2.

(Continued on Page 39)

# TROUBLESHOOTING MOTOR CURRENT DISPLAY

(Con't. From Page 38)

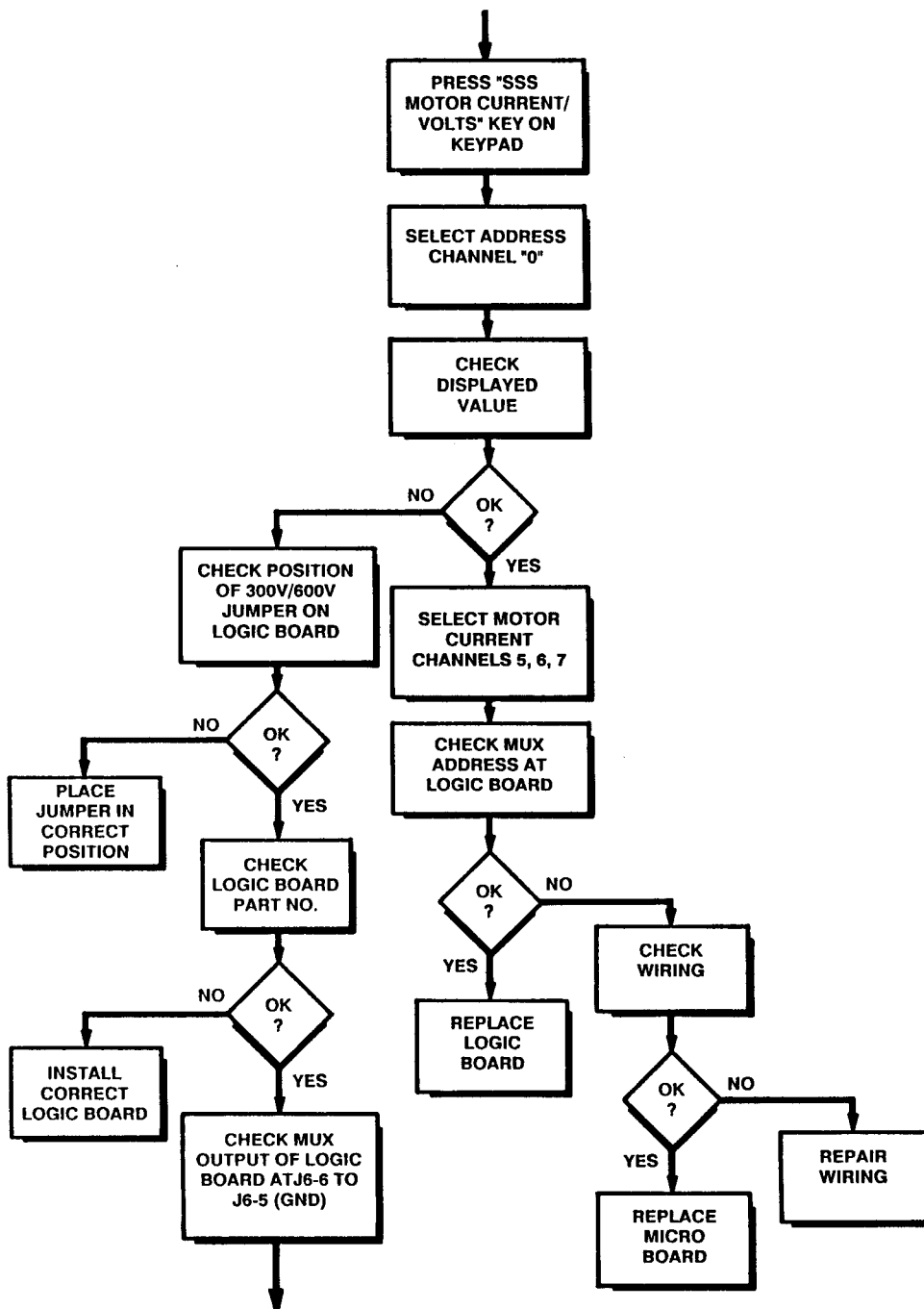

(Con't on Page 40)

SECTION  
**8**

# TROUBLESHOOTING MOTOR CURRENT DISPLAY

(Con't. From Page 39)

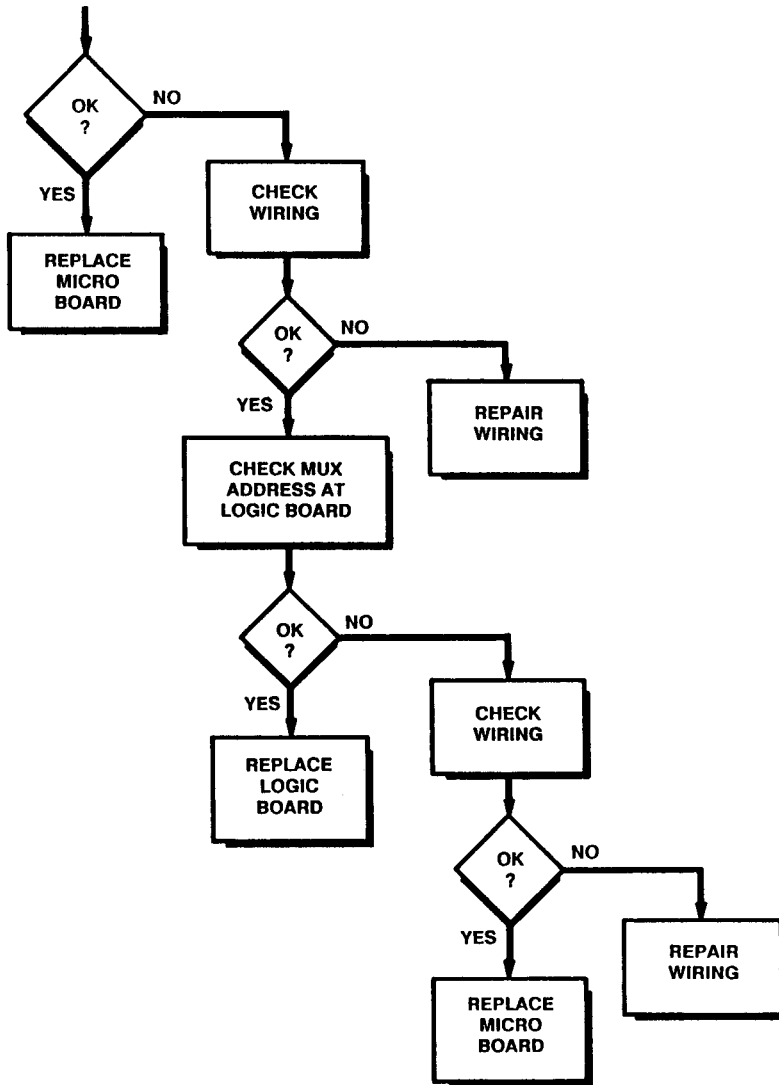

# TROUBLESHOOTING AC POWER LINE VOLTAGE DISPLAY

NOTE:  
1. Follow Software diagnostic instructions in MicroComputer Control Center Service Manual. See REFERENCE INSTRUCTIONS, page 2.

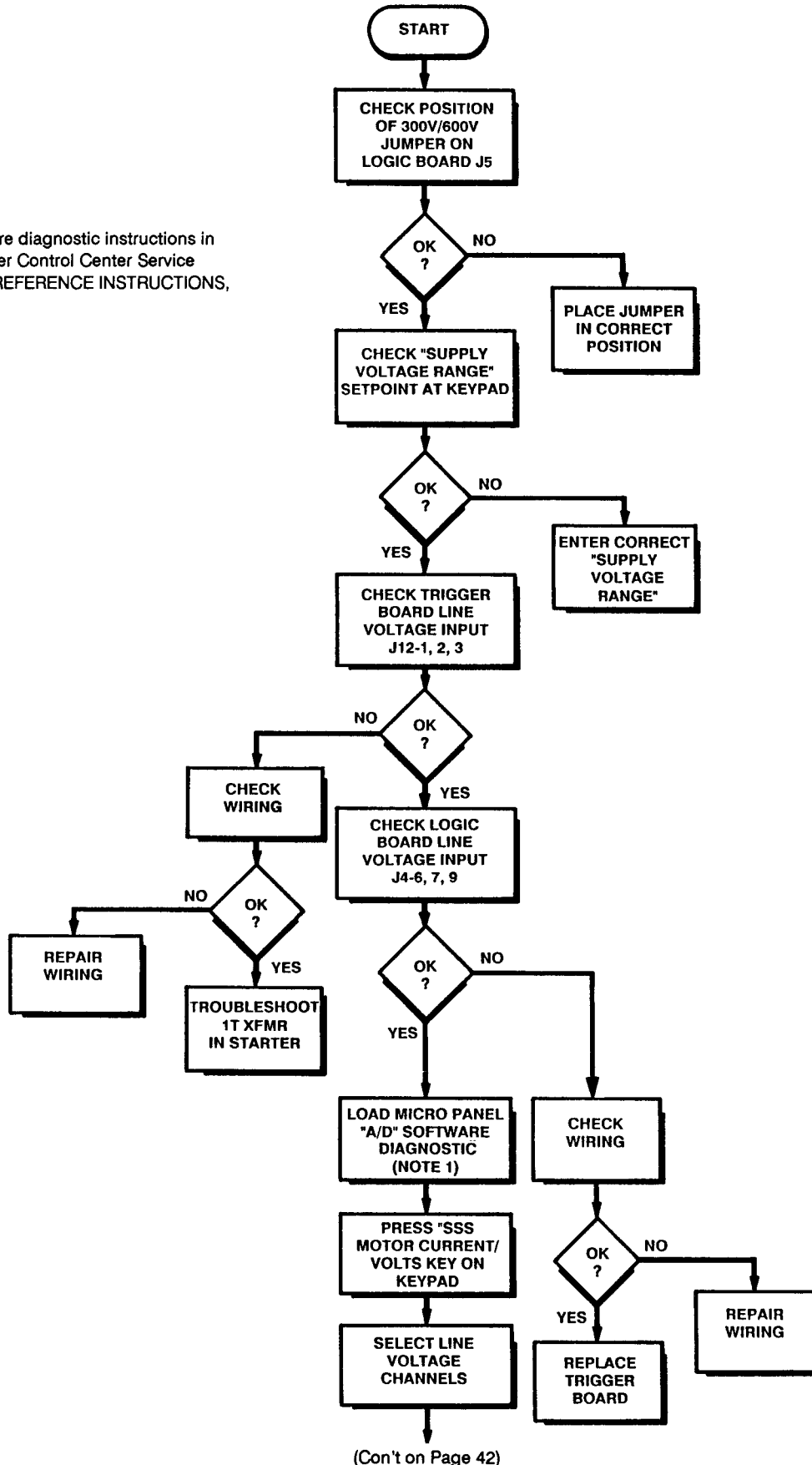

SECTION  
**8**

# TROUBLESHOOTING AC POWER LINE VOLTAGE DISPLAY

(Con't. From Page 41)

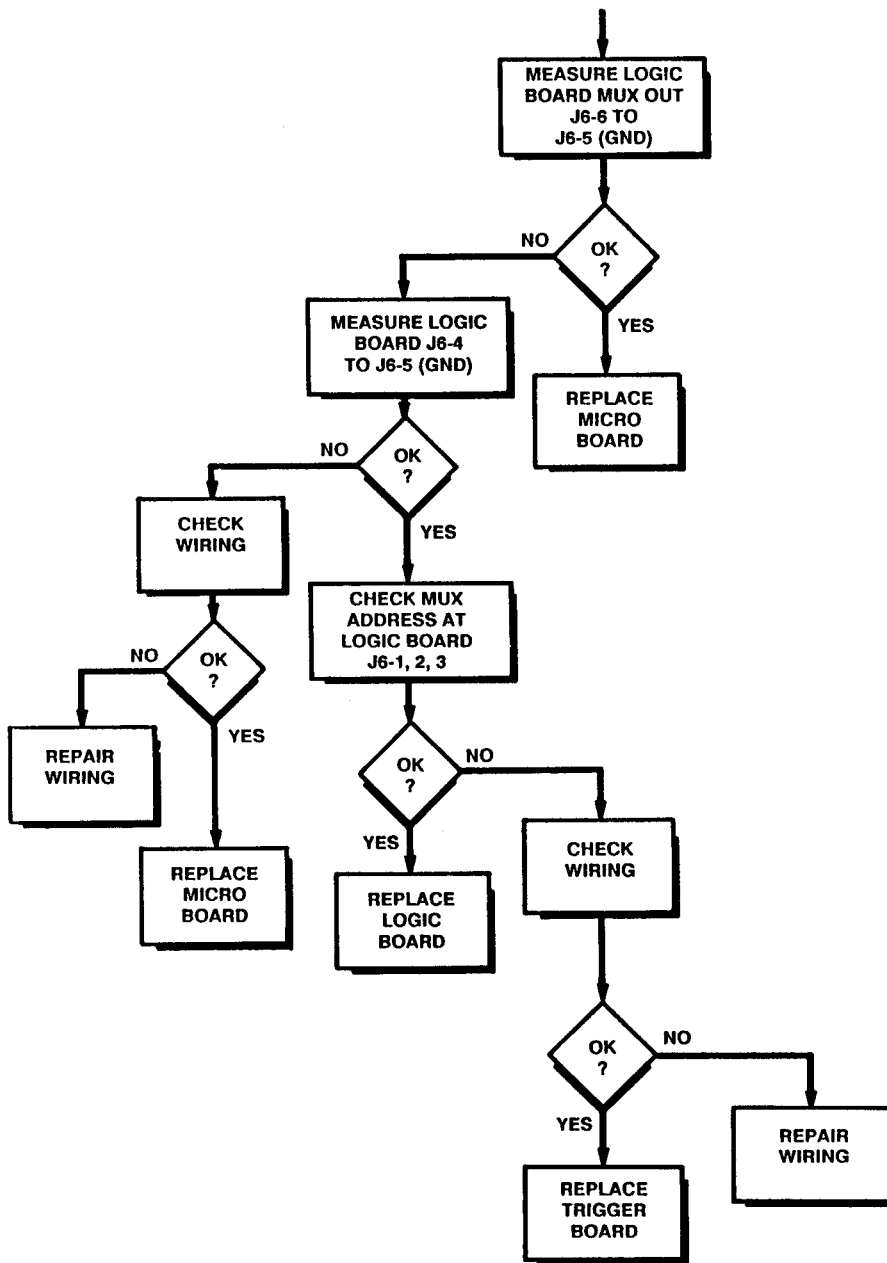

# TROUBLESHOOTING HALF PHASE

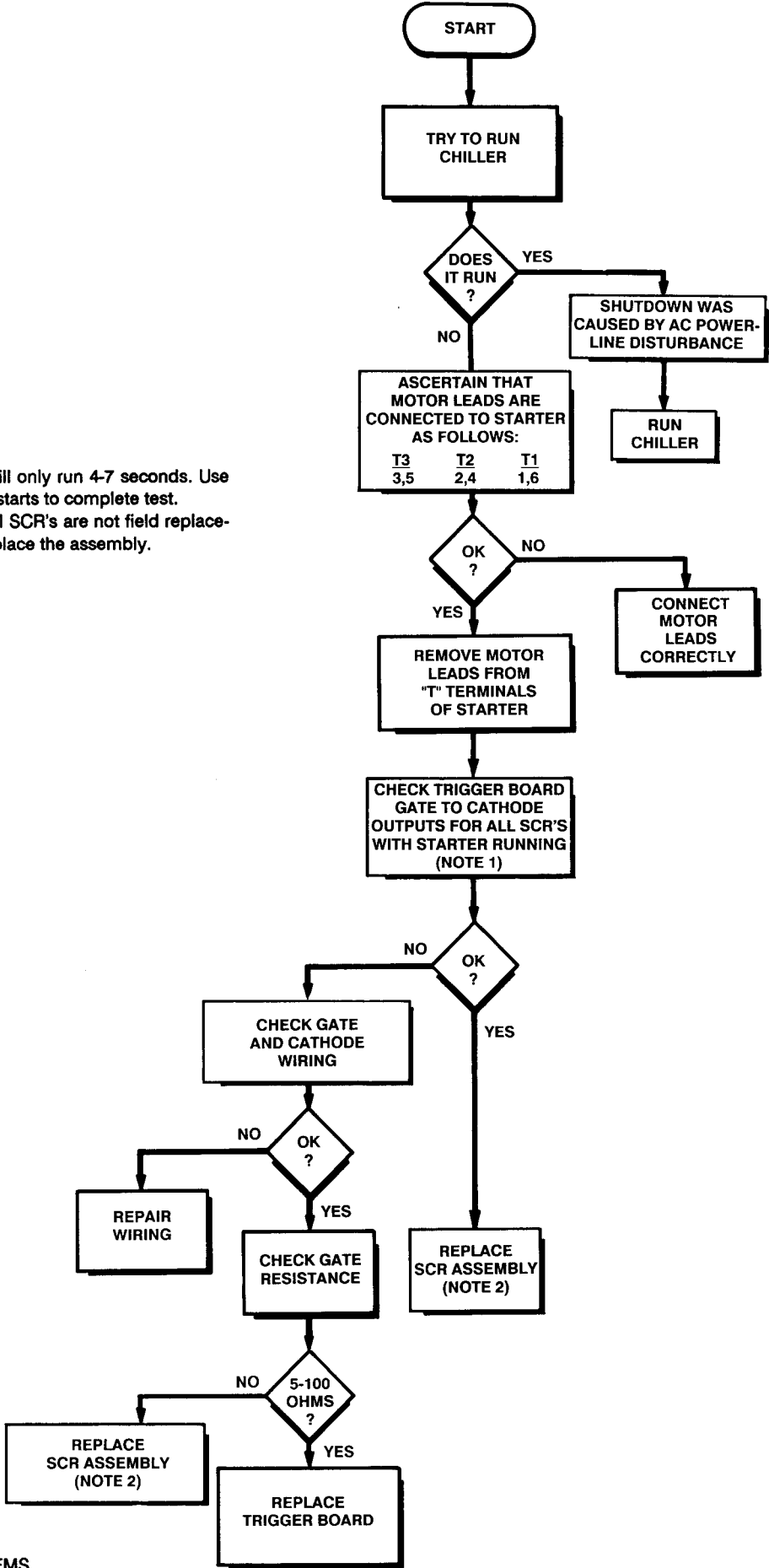

**NOTES:**

- 1. Starter will only run 4-7 seconds. Use multiple starts to complete test.
- 2. Individual SCR's are not field replaceable. Replace the assembly.

SECTION  
8



Proud Sponsor  
of the 1998  
U.S. Olympic Team

36USC380

---

P.O. Box 1592, York, Pennsylvania USA 17405-1592  
Copyright © by York International Corporation 1997  
Form 160.46-OM3.1 (1191)  
Supersedes: 160.46-OM3.1 (491)

Subject to change without notice. Printed in USA  
ALL RIGHTS RESERVED  
RPC 5M 297 2.20  
Codes: ERT & SJ4A