



P.O. Box 4808  
Carrier Parkway  
Syracuse, New York 13221

DOC. NO.	LAST NO.		
<b>Z-416</b>			
ISSUE DATE	12/15/04	PAGE	OF
		1	17
SUPERSEDES DOC. NO.		DATED	
Z-416		9/24/03	
APPROVED BY / DATE	QUALIFICATION APPROVAL / DATE	AUTHORIZATION NO.	REVISION
Scott Nieforth	N/A	194331D	D
REFERENCE:		STATUS:	
		RELEASED FOR PRODUCTION	

# Engineering Requirement

TITLE:		SUPERSEDES DOC. NO.		DATED	
VARIABLE FREQUENCY DRIVE - FOR CENTRIFUGAL CHILLER		Z-416		9/24/03	
APPROVED BY / DATE	QUALIFICATION APPROVAL / DATE	AUTHORIZATION NO.	REVISION		
Scott Nieforth	N/A	194331D	D		
REFERENCE:		STATUS:			
		RELEASED FOR PRODUCTION			

SECTION	TITLE	PAGE
<b>1.0</b>	<b>PURPOSE OF USE</b>	<b>2</b>
<b>2.0</b>	<b>APPLICATION</b>	<b>2</b>
2.1	Compressor Motors	2
2.2	Starting Methods	2
2.3	Non-Standard Equipment	2
<b>3.0</b>	<b>GENERAL</b>	<b>3</b>
3.1	Standards	3
3.2	Order processing documentation	3-5
3.3	Quality	5-6
3.4	Materials and Workmanship	6
3.5	Reliability	6
3.6	Ambient Operating Conditions	6
3.7	Shipping and Storage Conditions	6
3.8	Approved Suppliers	7
<b>4.0</b>	<b>GENERAL VFD EQUIPMENT</b>	<b>7</b>
4.1	Power System Protection	7
4.2	Ampere Rating	7
4.3	Enclosure	7
4.4	Power and Grounding Connections	8
4.5	Control Connections	8
4.6	Conductors	8
4.7	Control Transformer and Disconnect	8
4.8	Control Components	8
4.9	Oil Pump Circuit Breaker	9
4.10	Circuit Breaker With Shunt Trip And Short Circuit Protection	9
4.11	Identification	9-10
<b>5.0</b>	<b>VFD CONTROL INTERFACE WITH PIC I CONTROLS - SMM MODULE</b>	<b>10</b>
5.1	Relay and Contact Ratings	10-11
5.2	Load Limit Control Signal	11
5.3	Starter Management Module (SMM)	11
5.4	Control Power Transformer and Circuit Breaker	11
5.5	Potential Transformer	12
5.6	Pilot Relays	12

**PRINTED COPIES OF THIS DOCUMENT ARE UNCONTROLLED**

NO DEVIATION FROM THE CONSTRUCTION DEFINED BY AN APPROVED SAMPLE OR DETAILED SPECIFICATION (ON FILE IN THE ORDERING DIVISIONS ENGINEERING DEPARTMENT) WILL BE MADE WITHOUT WRITTEN APPROVAL FROM THE ORDERING DIVISIONS ENGINEERING DEPARTMENT.

*This document and the information contained therein is proprietary to Carrier Corporation and shall not be used or disclosed to others, in whole or in part, without the written authorization of Carrier Corporation.*

TITLE: VARIABLE FREQUENCY DRIVE - FOR CENTRIFUGAL CHILLER	DATE 12/15/04	DOCUMENT NUMBER <b>Z-416</b>
--	------------------	---------------------------------

SECTION	TITLE	PAGE
<b>6.0</b>	<b>VFD CONTROLS INTERFACE WITH PIC II CONTROLS - ISM MODULE</b>	<b>13</b>
6.1	Objective	13
6.2	ISM Supply Power, Terminal J1	13
6.3	ISM Contact Inputs, Terminal J2	13
6.4	Line Voltage Monitor, Terminal J3: L1-L3	13
6.5	Line Current Monitor, Terminal J4:IL1-IL3	13
6.6	Ground Fault Currents, Terminal J5: T1-T6	13
6.7	VFD Frequency Input, Configuration	13-14
6.8	ISM Dry Contact Outputs, Terminal J9	14
6.9	ISM Analog Output Terminals, J8	14-15
<b>7.0</b>	<b>OPTIONS</b>	<b>16</b>
7.1	Electromechanical Isolation	16
7.2	Emergency Bypass Starter	16
7.3	Enclosure	16
7.4	Surge Protection	16
7.5	Meters	16
7.6	Pumpout Unit Disconnect	16
7.7	Auxiliary Disconnect Devices	17
7.8	VFD Auxiliary Contacts	17
7.9	Watt Transducer	17
7.10	Modifications to Meet Special Codes	17
7.11	Miscellaneous	17

### 1.0 Purpose of Use:

This engineering requirement provides information and data needed to design, build, and apply a Variable Frequency Drive (VFD) for compressor motors on Carrier models that are controlled with either Carrier PIC I or PIC II controls.

In general, this specification is only applicable to the aforementioned model Chillers that have Carrier product integrated controls, version one and two (PIC I or PIC II).

### 2.0 Application:

#### 2.1 Compressor Motors

Motors to be started and controlled are NEMA B low voltage 50/60 Hz three-phase squirrel cage induction motors driving variable torque centrifugal refrigeration compressors. With a power supply phase rotation A-BC, motors rotate in the proper direction when phase A is connected to T 1, phase B is connected to T2 and phase C is connected to T3.

#### 2.2 Starting and Control Methods

2.2.1 Motors shall be started in the Delta winding configuration. Start commands shall only be honored from the Carrier (VFD) Starter interface module from either the PIC I or PIC II controller.

2.2.2 The PIC I controller will utilize a Carrier Starter Management Module (SMM) and a Carrier Processor Sensor input/output Module (PSIO) to interface with the VFD micro-controller. The VFD manufacturer will be required to integrate the SMM module into their drive, Carrier will be responsible for interfacing the PSIO to the drive for the speed control function. See section 5.0 for SMM interface requirements.

2.2.3 The PIC II controller will utilize a Carrier Integrated Starter Module (ISM) to interface with the VFD Micro-controller.

The VFD manufacturer will be responsible to integrate the ISM module into their drive. See section 6.0 for ISM interface requirements.

#### 2.3 Non-Standard Equipment

Prior approval by Carrier Engineering is required on a per job basis, for equipment not in accordance with or described in this requirement.

*This document and the information contained therein is proprietary to Carrier Corporation and shall not be used or disclosed to others, in whole or in part, without the written authorization of Carrier Corporation.*

TITLE: VARIABLE FREQUENCY DRIVE - FOR CENTRIFUGAL CHILLER	DATE 12/15/04	DOCUMENT NUMBER <b>Z-416</b>
--	------------------	---------------------------------

**3.0 General:**

## 3.1 Standards

VFD design and construction shall comply with the latest editions of the following standards applicable at the time of shipment.

3.1.1 ANSI/NEMA standards publication, industrial controls and systems, Publication # ICS 1,2,3,4,6 UL Standard 508.

3.1.2 Other applicable codes specified on the purchase order e.g. CE Marking.

3.1.3 The VFD shall be suitable for installation in accordance with the national electric code ANSI/NFPA70 or, in Canada, the Canadian Electrical Code.

3.1.4 The VFD shall be capable of meeting IEEE 519 through the use of an optional 12-pulse input and/or optional harmonic filters.

## 3.2 Order Process Documentation

3.2.1 Order Information from Carrier to the manufacturer will include the following information:

## 3.2.1.1 Job data

- (A) Carrier job numbers, name, ship to address and mark for.
- (B) When applicable, reference to customer specification and/or manufacturer quotation #.
- (C) Required manufacturer shipment date.
- (D) Carrier salesperson's name and address.
- (E) Special documentation requirements
- (F) Bill of materials, including the VFD Part Number and all options.
- (G) (If applicable) Drawing hold for approval

## 3.2.1.2 Specification and special codes

- (A) This equipment shall comply with the latest edition of Carrier Engineering Requirement Z-416.
- (B) (Only if applicable) this equipment shall comply with all national codes (name and number of national codes) applicable on the delivery date of the equipment.
- (C) (Only if applicable) this equipment shall comply with all local codes (name and number of local codes) applicable on the delivery date of the equipment.

## 3.2.1.3 Chiller Model and control type:

- (A) 19XL with PIC I controls
- (B) 19XR with PIC I controls
- (C) 19XR with PIC II controls

## 3.2.1.4 Line Data

- (A) Line voltage, phase, and frequency of the compressor drive motor and the oil pump motor.
- (B) Compressor motor rated load amperes, overload trip amperes and locked-rotor amperes.
- (C) (If applicable) Pumpout unit motor voltage phase and frequency.

## 3.2.1.5 VFD Field Installation data

- (A) Distance from motor (total cable length)
- (B) Location elevation if over 3300 ft. (1000 m) above sea level.
- (C) VFD configuration
  - Line Cable Entry: Bottom or top
  - Load Cable entry: Bottom or top.

*This document and the information contained therein is proprietary to Carrier Corporation and shall not be used or disclosed to others, in whole or in part, without the written authorization of Carrier Corporation.*

TITLE: VARIABLE FREQUENCY DRIVE - FOR CENTRIFUGAL CHILLER	DATE 12/15/04	DOCUMENT NUMBER <b>Z-416</b>
--	------------------	---------------------------------

3.2.1.6 Ambient Conditions

- (A) Ambient temperature, if over 104°F (40°C).
- (B) Special environmental conditions.

3.2.1.7 Part Number Legend

Carrier designations for options see section VFD shall be defined by a 14 digit Part Number as follows for PIC I Machines:

PIC II: Use Manufacturers Part Number

Model Design					Volt	Horse Power				VFD Config.		Rev	Part # Position
1	2	3	4	5	6	7	8	9	10	11	12	13	
3	2	V	F	D									Carrier Freestanding
					4								460 Volt Supply
					5								575 Volt Supply
						X	X	X	X				Horsepower
										0	6		6 Pulse Configuration
										1	2		12 Pulse Configuration
												A	Design Revision

3.2.2 Order Confirmation and Submittal Data

3.2.2.1 Order confirmation: This shall consist of:

(A) Acknowledgment copy of Carrier's purchase order reflecting

- 1. Information under 3.2.1
- 2. Promised ship date.
- 3. Price Discrepancies
- 4. Exceptions to any terms and conditions of order.

(B) Transmittal Sheet

Transmittal sheet reflecting job name, job number, Carrier order number, manufacturer references number, location of the manufacturer's service/sales office nearest the destination point (including contact name and phone number), and bill of material of all equipment, accessories, and modifications included in order.

3.2.2.1 Order confirmation continued: This shall consist of:

(C) VFD Outline Drawing, consisting of:

- 1. Overall dimension
- 2. VFD Performance data, Design line power, current/horsepower rating
- 3. Line and load connection detail
- 4. Minimum service clearance requirements.
- 5. Applicable lug sizes provided or to be provided. (Incoming/Outgoing)
- 6. Volt-ampere rating for control transformers.
- 7. This rating must also be indicated on the VFD schematic.
- 8. Short circuit interrupt rating.
- 9. Certification

(D) For accessories not installed within the VFD enclosure, corresponding outline drawings containing similar information, as well as how shipped and where to be installed.

*This document and the information contained therein is proprietary to Carrier Corporation and shall not be used or disclosed to others, in whole or in part, without the written authorization of Carrier Corporation.*

TITLE: VARIABLE FREQUENCY DRIVE - FOR CENTRIFUGAL CHILLER	DATE 12/15/04	DOCUMENT NUMBER <b>Z-416</b>
--	------------------	---------------------------------

### 3.2.2.2 Hold for Approval Submittal

- (A) Transmittal Sheet
- (B) Certified Dimensional Drawings
- (C) Schematic Diagrams
- (D) VFD delivery date based upon return date of approvals.

### 3.2.2.3 Final Submittals

This certified submittal shall include:

- (A) All Documentation under 3.2.2.2
- (B) Installation, Operation and Maintenance instructions parts catalog.

All of the above information except for the acknowledgment copy of Carrier's purchase order is to be sent as indicated on the purchase order to the Carrier salesman at the time of VFD shipment. In addition, one set is to be securely fastened to the VFD when shipped. Additional quantities to be noted on submittal order.

## 3.3 Quality, Testing, and Documentation

- 3.3.1 As part of a production quality program, completeness, correctness, and integrated functionality of each unit shall be verified prior to shipment.
- 3.3.2 Continuity of all wiring within the drive shall be checked, and additional UL or other agency tests shall be conducted including, but not limited to, insulation integrity (hi-pot) tests. Hi-pot tests shall not expose the ISM module to test voltages.
- 3.3.3 Drives shall be given a complete functional test by the supplier in which a 3-phase load is applied. As a minimum, this test shall include the power-up, start-up, transition (if applicable), up-to-speed, and shutdown operations of the drive when controlled by a PIC-II ICVC control module (Carrier part number CEPL 130445-01) or ISM test program (available from Carrier) using SIO communications. The 3-phase load shall be provided by a test motor and shall be made to simulate a minimum of 10% of the rated load current.
- 3.3.4 Functionality shall be demonstrated for all input and output circuitry which involve drive components other than the ISM (for example, ground fault protection).
  - 3.3.4.1 Circuits which are intended for current measurement or detection (e.g., using current transformers) shall have their output measured, calibrated to the required accuracy on each phase. Phase current shall be checked at 10% and 100% RLA, as a minimum. Ground fault or phase-to-phase fault circuits shall be checked at the configured trip level (ISM default = 15A) as a minimum. Appropriate measures shall be taken during both qualification and production to assure that reported currents meet accuracy requirements.
  - 3.3.4.2 The supplier shall enter starter (ISM) configuration parameters for the job in accordance with sales order and this document (except this does not apply to unit-mounted VFDs on 19XRV models).

*This document and the information contained therein is proprietary to Carrier Corporation and shall not be used or disclosed to others, in whole or in part, without the written authorization of Carrier Corporation.*

TITLE: VARIABLE FREQUENCY DRIVE - FOR CENTRIFUGAL CHILLER	DATE 12/15/04	DOCUMENT NUMBER <b>Z-416</b>
--	------------------	---------------------------------

3.3.5 The starter supplier shall establish and maintain records which provide evidence that the drive has been inspected and tested per the requirements of this specification. These records shall include drive assembly serial number, inspection and test failure records, and shall indicate the person who verified conformance to this requirement. Results of current and voltage measurement calibration and/or confirmation shall be included. For microprocessor-based control components, the serial number and version of hardware and version of software shall be permanently marked on the parts and retained in production quality records along with test documentation. The supplier shall maintain documentation which can be accessed either from the supplier's drive serial or from the associated Carrier 5-digit chiller serial number.

3.3.5.1 No hardware or software changes shall be made to the as-qualified assembly without pre-notification of and approval by Carrier Engineering, following Carrier's Supplier Deviation Request procedures.

3.3.5.2 For unit-mounted models, Carrier Engineering shall have review and approval rights regarding the contents of the production test.

3.4 Materials and Workmanship

Use only new materials. Appearance must be neat and orderly, should address Carrier Quality Standards.

3.5 Reliability

System Reliability	As Shipped	99.9%
	First 100 Operating Hours	98.0%
	First 3600 Operating Hours	93.0%
	First 15 Years	90.0
Component Reliability	First 3600 Operating Hours	99.8%

Reliability Requirement assumes scheduled maintenance as recommended by the manufacturer. The typical VFD operates 3600 more hours/year.

Minimum number of starts is 20,000 with a nominal 15-minute interval between starts. (15-minute start-to-start interval provided by Carrier controls. Minimum interval between starts can be 2 minutes with manual override of controls).

3.6 Ambient Operating Conditions

Temperature 40°F. to 104°F. (5°C. to 40°C.)  
 This is the temperature of the space in which the VFD is located. The maximum temperature inside the VFD is 40°C plus the temperature rise of the VFD.

Relative Humidity 0% min., 98% max.  
 Location Elevation 3300-ft. (1000 m) max. with appropriate de-rate at higher elevation.

3.7 Shipping and Storage Conditions

Temperature 13°F. to 140°F. (25°C. to 60°C.)  
 Relative Humidity 10% min., 100% max.(non condensing)  
 Packaging VFD shall be adequately packaged to provide protection  
 From exposure to the elements and damage encountered  
 During normal shipping and sheltered storage

*This document and the information contained therein is proprietary to Carrier Corporation and shall not be used or disclosed to others, in whole or in part, without the written authorization of Carrier Corporation.*

TITLE: VARIABLE FREQUENCY DRIVE - FOR CENTRIFUGAL CHILLER	DATE 12/15/04	DOCUMENT NUMBER <b>Z-416</b>
--	------------------	---------------------------------

### 3.8 Approved Suppliers

3.8.1 Toshiba International

3.8.2 Reliance Electric

### 4.0 General VFD Equipment:

#### 4.1 Power System Protection

The VFD micro controller shall provide protection. Fault contacts shall be connected in the Carrier VFD fault circuit as shown on the schematic.

##### 4.1.1 Under voltage Protection (UV)

Fault contact shall be closed under normal DC Bus voltage conditions and opens when DC Bus voltage is < 90% below design voltage. Automatic fault reset after a 10-second minimum time delay.

##### 4.1.2 Over voltage Protection (OV)

Fault contact shall be closed under normal DC Bus voltage conditions and opens when DC Bus voltage is > 110% above design volts. Automatic reset after a 10-second minimum time delay.

##### 4.1.3 Ground Fault Protection

Low level, instantaneous ground fault.

##### 4.1.4 Motor over Current Protection

Allow continuous operation up to 105% of selected motor rating. Above that utilize I<sup>2</sup>T protection of the motor for all 3 phases.

##### 4.1.5 Phase Failure and Phase Unbalance Protection

Current or voltage sensing three-phase monitor to detect phase loss and phase unbalance. Manual or automatic reset normally closed contacts. Automatic reset after a 10-second minimum time delay. Calibrate relay to trip when voltage unbalance is more than 10%.

#### 4.2 Ampere Rating

The VFD manufacturer shall verify that VFD rating is suitable for motor load specified. If an improper size VFD is specified, the manufacturer shall notify Carrier and defer further action pending receipt official change notice.

4.2.1 VFD Load side over current rating: 105% continuous.

#### 4.3 Enclosure

4.3.1 Floor mounted, sheet steel NEMA type 1 enclosure, hinged front interlocked access door(s), provision for base mounting, free standing, formed, assembled, and braced into a rigid self-supporting structure, accommodating all basic VFD equipment, accessories, and modifications, all completely factory installed, wired, and connected.

4.3.2 Doors must be lockable in the closed position.

4.3.3 All metal surfaces, inside and out, to be phosphatized, or cleaned and primed with a suitable corrosion inhibitor, finish enamel topcoat, or equivalent.

*This document and the information contained therein is proprietary to Carrier Corporation and shall not be used or disclosed to others, in whole or in part, without the written authorization of Carrier Corporation.*

TITLE: VARIABLE FREQUENCY DRIVE - FOR CENTRIFUGAL CHILLER	DATE 12/15/04	DOCUMENT NUMBER <b>Z-416</b>
--	------------------	---------------------------------

#### 4.4 Power and Grounding Connections

Lugs for line and load power connections shall be located to provide adequate clearance for easy connection of cables for either top or bottom entry. Entry location per job order. Terminals and lugs must be UL listed for use with copper conductors. A ground lug or lugs for line and load connections must be provided. All lugs must be sized for cables selected per National Electric Code.

#### 4.5 Control Connections

- 4.5.1 Terminal blocks required for customer connections shall be mounted on a non-hinged stationary part of the enclosure case of access and permanently and clearly identified to match schematic and wiring diagrams.
- 4.5.2 Allow adequate clearance for easy connection of field wiring.
- 4.5.3 Include a field wiring terminal block, which provides all terminals for basic VFD functionality and those required for specified modifications, separated and identified by voltage and arranged in numerical sequence.
- 4.5.4 Use screw clamp pressure plate terminals rated for at least 10 Amps, and for at least line voltage. Class 1 wire size is to be 14 AWG.
- 4.5.5 Keep all internal panel wiring on one side of terminal block. Opposite side shall be used exclusively for field conductors.
- 4.5.6. Do not connect more than three wires per terminal, add extra blocks, and factory formed jumpers to obtain required functionality.

#### 4.6 Conductors

- 4.6.1 Provide continuously rated copper main conductors. Conductors must be properly designed for at least the basic VFD withstand short circuit current, or for the interrupting capacity specified. All control and power cable is to be stranded copper, 18 AWG minimum size type THNN, THWN MTW, or equivalent.
- 4.6.2 Conductors carrying 120 volts shall be Class 1 14 AWG.
- 4.6.3 Conductors carrying 30V or less shall be separated from higher voltage conductors. They shall not be located in the same bundle or raceway.

#### 4.7 Control Transformer and Disconnect

##### 4.7.1 Control Power Circuit Breaker

Provide one 2-pole, 15-amp circuit breaker connected to the line side of the VFD circuit breaker.

##### 4.7.2 Control Power Transformer

- (A) **PIC I:** Provide a 2 KVA control power transformer. Fuse the transformer secondary at 20 amps. Connect the primary to the load side of the control power circuit breaker.
- (B) **PIC II:** Provide a 3 KVA control power transformer.

#### 4.8 Control Components

- 4.8.1 Provide control components in accordance with diagrams and/or to perform all necessary functions stated in this specification.
- 4.8.2 No contacts are allowed in the grounded (neutral side) of relay coils or other devices.
- 4.8.3 Control relays shall have 300V rated contacts for 115V circuits, quantity, and type as required.
- 4.8.4 Only industrial or heavy-duty pushbutton switches, indicating lights, or control switches shall be mounted on front of enclosure.

*This document and the information contained therein is proprietary to Carrier Corporation and shall not be used or disclosed to others, in whole or in part, without the written authorization of Carrier Corporation.*

TITLE: VARIABLE FREQUENCY DRIVE - FOR CENTRIFUGAL CHILLER	DATE 12/15/04	DOCUMENT NUMBER <b>Z-416</b>
--	------------------	---------------------------------

#### 4.9 Oil Pump Circuit Breaker

Provide one 15 amp (except 20 amp for 300line volts and less), 3-phase circuit breaker connected to the line side of the VFD disconnect. Connect the load side of the breaker to terminals labeled OS1, OS2, and OS3.

#### 4.10 Circuit Breaker with Shunt Trip and Short Circuit Protection

Provide a door-interlocked, externally gang-operated, three-pole main power disconnect means, including mechanical position indicator on enclosure exterior and short circuit protective means. Coordinate short circuit protection with the drive fault. Provide a means of pad locking the disconnect in the open position.

##### 4.10.1 Short Circuit Protection

- (A) Circuit breaker will provide short circuit protection for the Fault Rating of the drive.
- (B) Current rating must consider temperature rating within the VFD. Protection will be for each phase.
- (C) Provide a molded cased circuit breaker with an instantaneous over current element in each phase set for the maximum current allowed by code.

##### 4.10.2 Disconnecting

Disconnecting means the circuit breaker shall be capable of disconnecting main power to the drive and be capable of being locked out.

##### 4.10.3 Interlock

The circuit breaker shall be interlocked with the door of the VFD.

#### 4.11 Identification

4.11.1 All identification shall be clearly legible and permanent.

4.11.2 A nameplate on the door of the enclosure shall include the Carrier P/N and the VFD serial number.

4.11.3 Provide symbols and labeling(s) to meet warning and safety requirements of all applicable codes, including but not limited to OSHA (Standards-29 CFR) 1910.145 – specifications for accident prevention signs and tags and American National Standard Z53.1-1967.

4.11.4 Affix a label stating: "This equipment conforms with Carrier Engineering Requirement Z-416."

4.11.5 Permanently attach a copy of the detailed schematic and wiring diagram(s) to inside of control enclosure front door or some other accessible internal surface, or enclose in transparent film. Drawing shall be of best quality reproduction, good definition, non-fading, easy to read and absolutely legible. A basic schematic plus options sheets may be used as long as included options are clearly identified.

4.11.6 Permanently identify all components and terminals corresponding to drawings. Component identification must be attached to a non-removable, unobstructed surface.

4.11.7 Install UL/CUL, ETL, CSA or other agency label on recognized or listed VFDs if specified.

4.11.8 Affix a label adjacent to all 120-volt field wiring terminal strips stating: "Danger! Electrical shock hazard due to back-feeding of voltage through control power transformer. Do not connect external 120 V power source to this terminal strip."

4.11.9 Affix a label in prominent position stating:

"Important: The field wiring terminal connectors supplied on this controller are suitable for use with copper conductors only. If user/installer elects to use aluminum conductors, the sole responsibility for adequate termination is his own. Successful use of aluminum requires special care and maintenance and falls beyond the scope of normal equipment warranties."

*This document and the information contained therein is proprietary to Carrier Corporation and shall not be used or disclosed to others, in whole or in part, without the written authorization of Carrier Corporation.*

TITLE: VARIABLE FREQUENCY DRIVE - FOR CENTRIFUGAL CHILLER	DATE 12/15/04	DOCUMENT NUMBER <b>Z-416</b>
--	------------------	---------------------------------

4.11.10 Affix label near overload relays or in prominent position stating:

"This overload is factory set and shall not be adjusted."

4.11.11 Label each end or color-code all conductors. All conductors which can be above 50 volts when the main disconnect is open shall be colored solid yellow. Neutral conductors shall be white. Ground conductors shall be green.

4.11.12 Affix a label inside the VFD door providing the department and phone number of the person to call in the event that service is required. The name is not required if the number is for a warranty administration or customer service department.

4.11.13 The following warning labels or their equivalent must be applied to the outside of the front door of the enclosure adjacent to the handle of the circuit breaker.

"Danger Electric Shock Hazard this disconnect may not de-energize all internal circuits. Open all internal and remote disconnects including the control power and/or oil heater and/or oil pump disconnects before servicing this equipment."

"Danger Electric Shock Hazard High voltage is at load side terminals and motor terminals when VFD is turned off. Disconnect main power before servicing equipment."

#### **5.0 VFD Control Interface With PIC I Controls - SMM Module:**

Carrier Starter Management Module (SMM): via closure of ICR contact.

Primary speed control shall be a 4-20mA signal.

Backup speed control shall be rated frequency.

The Chiller VFD interface schematic is shown on Figure 2.

Carrier drawing no. 19XB05003001 is to be incorporated into the VFD manufacturer's schematic. All references to "starter" shall assume the meaning "VFD."

#### **5.1 Relay and Contact Ratings**

Relay, contactor coils and contacts, which interface with the chiller control, must operate reliably under the following conditions.

5.1.1 1M Contactor Aux. (for SMM input)-Closes when VFD initiates Start and Opens when VFD is stopped.

5.1.2 2M Run Contactor Aux. -Closes when VFD reaches minimum speed and remains closed until stopped.

5.1.3 1M Feedback contact (for terms 50 & 51) - Closes when VFD initiates start or when there is current to the motor. Opens when VFD stops and there is no current.

5.1.4 Overload Protection

A three-phase solid state or electronic overload shall protect the motor during both start and run.

TITLE: VARIABLE FREQUENCY DRIVE - FOR CENTRIFUGAL CHILLER	DATE 12/15/04	DOCUMENT NUMBER <b>Z-416</b>
--	------------------	---------------------------------

Table 1

## Coil and Contact Requirements

Coil Requirements	Nominal Voltage	Min. Pick-up Voltage	Max. Inrush Current	Max. Sealed Current	Must Drop-Out Amps-Volts
<b>1. Devices</b>	<b>2.</b>	<b>3.</b>	<b>4.</b>	<b>5.</b>	<b>6.</b>
1 CR Pilot Relays	24 VDC	18 VDC	60 mA	60 mA	10 mA@ 24 VDC

Contact Requirements	Nominal Voltage	Min. Voltage	Maximum Current	Minimum Current
<b>6.1. Devices</b>	<b>6.2.</b>	<b>6.3.</b>	<b>6.4.</b>	<b>6.5.</b>
1 M Contactor Aux. (for SMM input) 2M Run Contactor Aux.	24 VDC	18 VDC	2 mA	0.5 mA
Overload Protection relays stop button	24 VDC	18 VDC	60 mA	10 mA @ 24 VDC
IM Contactor Aux. (for terms (50 & 51))	24 VDC	18 VDC	2.0 A	0.4 A
Pilot Relays	115/600 VDC		10/3 A	0.5/0.1 A

## 5.2 Load Limit Control Signal

Provide a  $0.5 \pm 0.1$  VAC load limit control signal proportioned to motor current, i.e.: 0.0 volts at no load and 0.5 volts at rated load amps for the compressor motor. Connect the voltage signal to terminals as indicated in figure 2, using a shielded twisted pair cable with the shield grounded.

If a current transformer and signal resistor combination is used for this purpose, the circuitry must be made continuous and permanent to avoid the possibility of open-circuit transformer voltage. The non-sinusoidal output current waveform shall be considered when sizing the transformer and signal resistor.

If a system other than a current transformer and signal resistor is used to generate this signal, prior approval by Carrier is required.

## 5.3 Starter Management Module (SMM)

Provide a Starter Management Module, Carrier P/N CES0121319, located at least 1foot from all main motor conductors and contactors and wired as shown on Figure 2.

For all VFDs going to European common market country, install an electromagnet shield per Carrier Drawing 19XB050112301 over the SMM.

## 5.4 Control Power Transformer and Circuit Breaker

Provide a 24 V, 40 VA control power transformer and 3 amp circuit breaker to power the starter management module as shown on Figure 2.

*Note: The starter management module with instructions may be ordered as package P/N 9XB04004101.*

*This document and the information contained therein is proprietary to Carrier Corporation and shall not be used or disclosed to others, in whole or in part, without the written authorization of Carrier Corporation.*

TITLE: VARIABLE FREQUENCY DRIVE - FOR CENTRIFUGAL CHILLER	DATE 12/15/04	DOCUMENT NUMBER <b>Z-416</b>
--	------------------	---------------------------------

5.5 Potential Transformer

Provide a potential transformer (separate from the SMM control power transformer) with a 24 +/-6.0 VAC output at motor rated voltage. Connect as shown on Figure 2.

5.6 Pilot Relays

Provide 5 pilot relays and connect as shown on Figure 2. Coil and contact ratings are specified in Section 5.3.

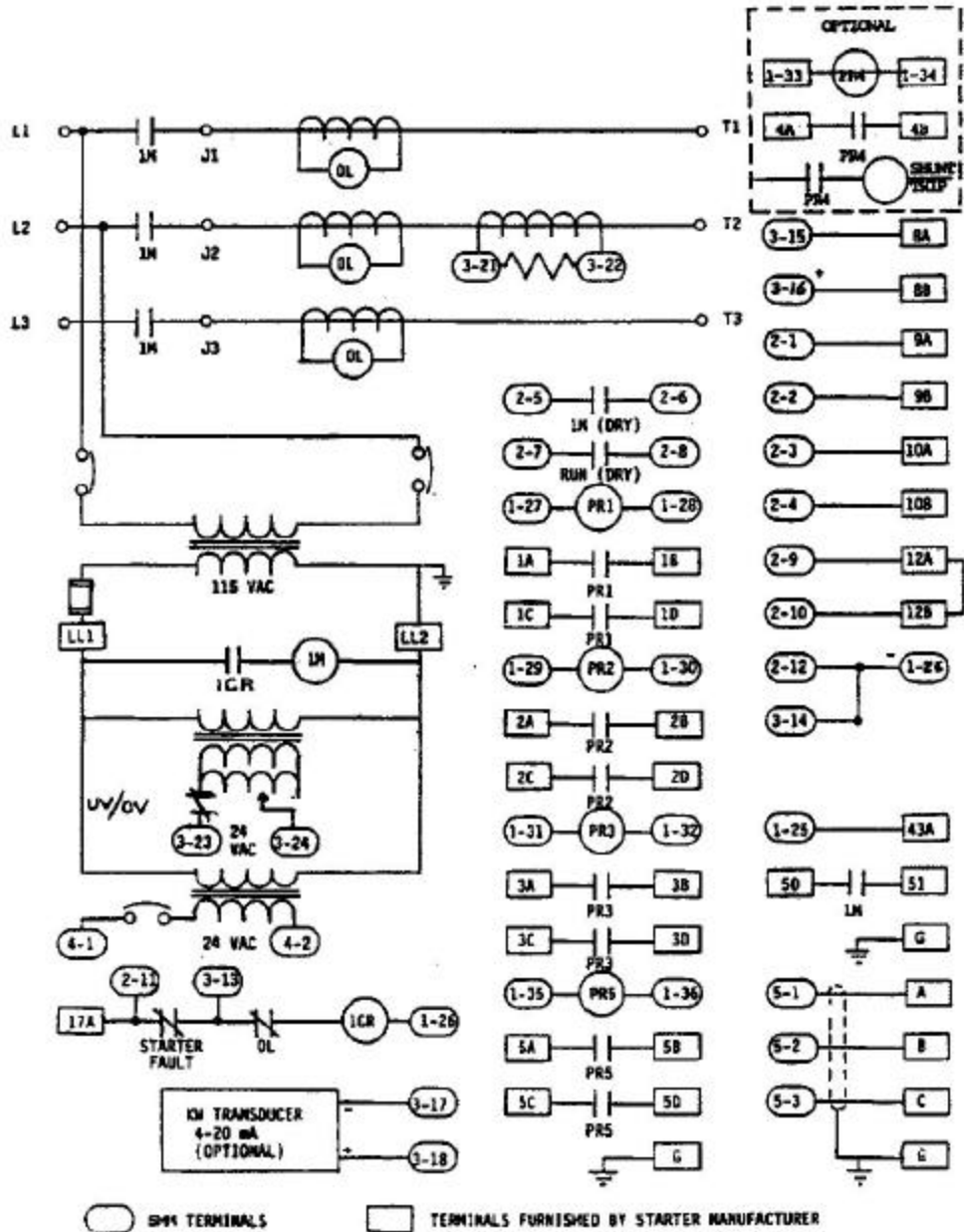

This document and the information contained therein is proprietary to Carrier Corporation and shall not be used or disclosed to others, in whole or in part, without the written authorization of Carrier Corporation.

TITLE: VARIABLE FREQUENCY DRIVE - FOR CENTRIFUGAL CHILLER	DATE 12/15/04	DOCUMENT NUMBER <b>Z-416</b>
--	------------------	---------------------------------

## 6.0 VFD Control Interface with PIC II Controls - ISM Module:

6.1 Objective: The objective of using this module is to provide communication from VFD to Carrier chiller controls and monitoring of safeties. The ISM will be installed by the VFD manufacturer. See Figure # 1

6.1.1 ISM Carrier Part #: CES0130037.

### 6.2 ISM Supply Power, Terminal J1

120 Volt supplies power to terminals LL1 & Terminals LL2. Power from control transformer section 4.8.2.

### 6.3 ISM Contact Inputs, Terminal J2

6.3.1 Spare Safety, (J2: 1, 2), Optional safety, no VFD connection is required.

6.3.2 Ice Build, (J2: 3, 4), Optional safety used by customer to request Chiller Controls operate to build ice. No VFD connection is required.

6.3.3 Remote Start, (J2: 5, 6), Customer remote start request. No VFD connection is required.

6.3.4 Starter Fault, (J2: 7, 8), Starter fault indication. VFD controls will use this to indicate the drive has shut down on a fault condition out of range. Shielded cable must be used between the VFD and the ISM, with the ISM end of the shielding grounded and the VFD end ungrounded.

6.3.5 1M AUX., (J2: 9, 10), Start relay (1M) position indication. Closure provides confirmation from VFD controls of start command. Shielded cable must be used between the VFD and the ISM, with the ISM end of the shielding grounded and the VFD end ungrounded.

6.3.6 2M AUX., (J2: 11, 12), Run Relay(2M) Closure provides confirmation that the VFD has reached the preset minimum speed. Shielded cable must be used between the VFD and the ISM, with the ISM end of the shielding grounded and the VFD end ungrounded.

VFD minimum speed relay must be closed with 20 seconds or chiller controls will trip the VFD.

### 6.4 ISM Line Voltage Monitor, Terminal (J3: L1, L2, L3).

Connects to the line voltage to monitor and verify that the line voltage is within specified design parameters. Potential transformer is required for line voltages over 600 volts AC.

### 6.5 ISM Line Current Monitor, Terminal (J4: IL1, IL2, IL3)

Connects to the current transformers (CT) that are monitoring the VFD line current. Used to monitor and verify that the line current draw is within specified design parameters. Interfaces through CT are defined in Required instruments:

6.5.1 3 Current Transformers.

6.5.2 Located on the line side of the drive.

6.5.3 Ratio selection such that the full loads amps on the primary side translates to 3.75 - 4.5 amps on the secondary. Current transformer ratio must be between 3:1 and 1000:1. Ratio selection such that the full load amps on the primary side translates to 3.75 to 4.5 amps on the secondary with a 1.0 ohm burden.

6.5.4 CT Burden: size for 1 $\Omega$  impedance.

### 6.6 ISM Ground Fault Currents, Terminal (J5: 1, 2, 3, 4, 5, 6)

6.6.1 The Phase/Ground fault current transformer ration shall be 150:1 with accuracy of +/-10% of actual value at a 10 ohm burden with a ground fault current between 1 and 25 amps. Suppliers should verify that CTs selected for this option provide the desired output level for a primary signal which matches the configured ground fault trip level(e.g. default level of 15 amps)

*This document and the information contained therein is proprietary to Carrier Corporation and shall not be used or disclosed to others, in whole or in part, without the written authorization of Carrier Corporation.*

TITLE: VARIABLE FREQUENCY DRIVE - FOR CENTRIFUGAL CHILLER	DATE 12/15/04	DOCUMENT NUMBER <b>Z-416</b>
--	------------------	---------------------------------

6.7 ISM VFD Frequency Input Terminal (J6: 1, 2), Analog input terminal that provides VFD operating frequency feedback, 0-5 VDC signal. Shielded cable must be used between the VFD, the signal isolator, and the ISM with the ISM end of the shielding grounded and the VFD end ungrounded.

6.7.1 60 Hz applications scale

6.7.1.1 0 VDC equates to 0 Hz.

6.7.1.2 5 VDC equates to 60 Hz.

6.7.2 50 Hz applications scale

6.7.2.1 0 VDC equates to 0 Hz.

6.7.2.2 5 VDC equates to 50 Hz.

6.8 ISM Dry Contact Outputs, Terminal J9.

6.8.1 1 CR, (J9: 1, 2), Start, Stop and Run Command. Closes at start and remains closed during chiller operation. One of two devices that complete the circuit to the 1M relay, see section 6.3.5.

6.8.2 Trans, (J9: 3, 4), Transition Command. Control for a reduced voltage starter. Not used with the VFD application.

6.8.3 Shunt Trip, (J9: 5, 6), Control for the shunt trip breaker. Provides a contact for the control of a shunt disconnect/breaker. Shunt breaker is required when PIC II controls are specified

6.8.4 Evaporator Pump (J9: 7, 8), Evaporator Pump run command. Customer connection to interface chiller controls with the evaporator condenser pump starter.

6.8.5 Condenser Pump, (J9: 9, 10), Condenser Pump run command. Customer connection to interface chiller controls with the condenser brine pump starter.

6.8.6 Low Fan, (J9: 11, 12), Tower fan low speed run command. Customer connection to interface the chiller controls with the tower fan controller or starter.

6.8.7 High Fan, (J9: 13, 14), Tower fan high-speed run command. Customer connection to interface the chiller controls with the tower fan controller or starter.

6.8.8 Trip Alarm, (J9: 15, 16), Chiller trip or alarm contact for customer connection or monitoring.

6.9 ISM Analog Output, Terminal J8

Shielded cable must be used between the VFD, the signal isolator, and the ISM with the ISM end of the shielding grounded and the VFD end ungrounded.

6.9.1 VFD, (J8: 1, 2) VFD frequency command signal, 4-20mA. Provides linear speed command to the VFD controller. Configured as follows:

6.9.1.1 60 Hz applications scale.

6.9.1.1.1 4 mA equates to 0 Hz.

6.9.1.1.2 20 mA equates to 60 Hz.

6.9.1.2 50 Hz applications scale

6.9.1.2.1 4 mA equates to 0 Hz

6.9.1.2.2 20 mA equates to 50 Hz.

6.9.2 Isolation for 4-20 mA and 0-5 VDC circuit to ground loop currents.

*This document and the information contained therein is proprietary to Carrier Corporation and shall not be used or disclosed to others, in whole or in part, without the written authorization of Carrier Corporation.*

TITLE:  
VARIABLE FREQUENCY DRIVE - FOR CENTRIFUGAL CHILLER

DATE  
12/15/04

DOCUMENT NUMBER  
**Z-416**

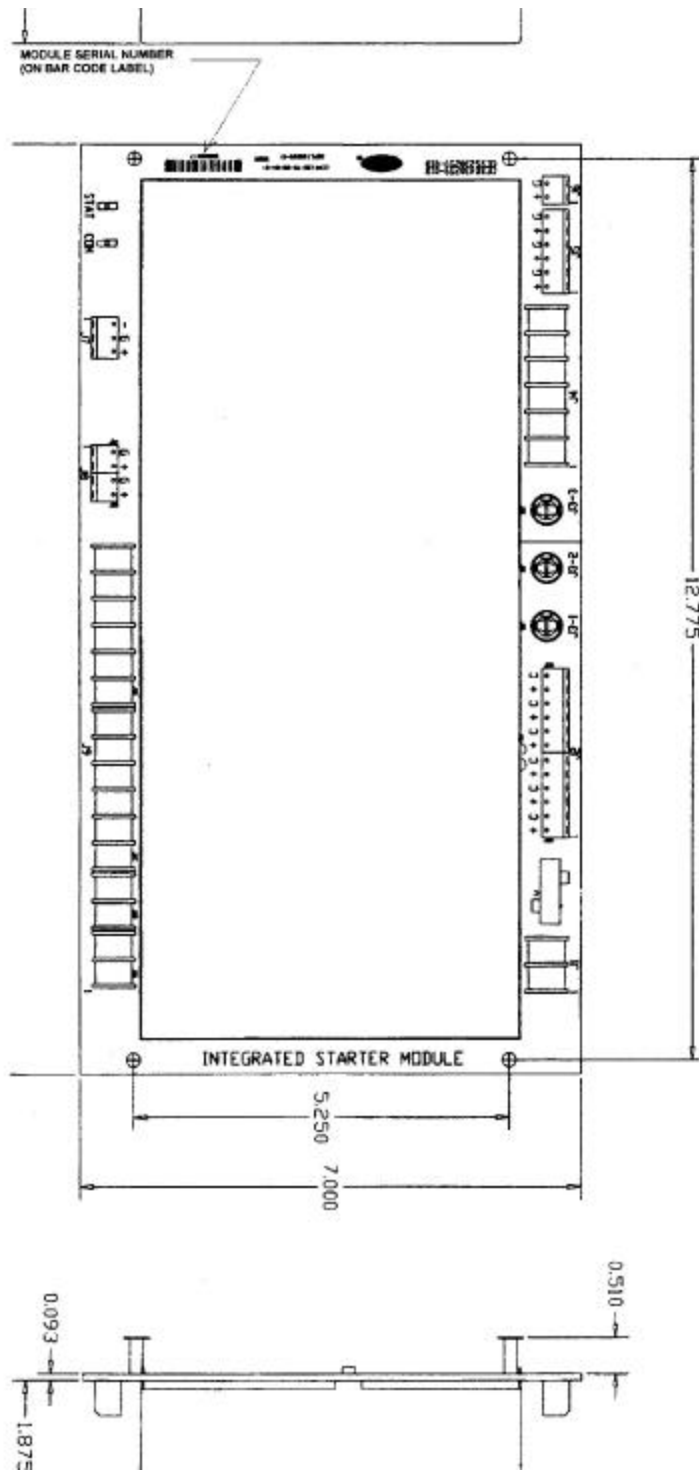

FIGURE 1

*This document and the information contained therein is proprietary to Carrier Corporation and shall not be used or disclosed to others, in whole or in part, without the written authorization of Carrier Corporation.*

TITLE:

VARIABLE FREQUENCY DRIVE - FOR CENTRIFUGAL CHILLER

DATE

12/15/04

DOCUMENT NUMBER

**Z-416****7.0 Options:**

## 7.1 Electromechanical Isolation

An isolation contactor which closes after the motor is stopped may be provided if specified.

If a load break isolation contactor is provided, it may be utilized for electromechanical isolation (auto reset), as well as a means of disconnecting the VFD in the event that a fault is detected (manual reset).

## 7.2 Emergency Bypass Starter

A starter, which bypasses the VFD, may be provided, if specified. This contactor shall operate from the VFD's chiller control interface instead of the VFD to start and stop the motor. All required inputs to the chiller control shall be maintained to satisfy all start, run, and stop requirements. The bypass starter can either be Y-Delta or soft starting solid-state starter.

## 7.3 Enclosure

7.3.1 NEMA types 12, 4.

7.3.2 Special color paint (exterior only) when required.

7.3.3 Special paint (exterior and interior) when required.

7.3.4 Kirk key interlock or equivalent

7.3.5 Space Heater

## 7.4 Surge Protection

Surge protection capacitors and lightning arresters are to be installed on the line side of VFD disconnect, unless otherwise specified.

## 7.5 Meters

Meters are to have a 1 1/2" minimum scale and be installed on the front door of VFD's. Install required current transformers and potential transformers with fuse protection of the appropriate accuracy and burden. Metering current transformers shall be installed on the line side of the VFD module.

7.5.1 Ammeter, single phase

7.5.2 Ammeter with three-phase, four position selector switch

7.5.3 Volt meter, single phase

7.5.4 Volt meter with three-phase, four position selector switch

7.5.5 Watt-hour meter, three-phase

7.5.6 Wattmeter, three-phase

7.5.7 Power factor meter

7.5.8 Analog frequency meter co

*This document and the information contained therein is proprietary to Carrier Corporation and shall not be used or disclosed to others, in whole or in part, without the written authorization of Carrier Corporation.*

TITLE: VARIABLE FREQUENCY DRIVE - FOR CENTRIFUGAL CHILLER	DATE 12/15/04	DOCUMENT NUMBER <b>Z-416</b>
--	------------------	---------------------------------

#### 7.6 Pumpout Unit Disconnect

Install a 600-Volt, min. 15 amp, three-pole circuit breaker mounted in main compressor VFD enclosure. Label accordingly.

#### 7.7 Auxiliary Disconnect Devices

If an additional auxiliary disconnect device, such as for oil pump, control power or oil heater is ordered, it must be installed in the main VFD enclosure, the device shall be installed such that the operating handle is within the main enclosure and not operable from the outside. The taps between the primary over current protection and the power source must be less than 10' long and must have short circuit and over current protection in each leg.

The auxiliary disconnect device shall be wired to the line side of the main motor circuit breaker.

The disconnect device must be a circuit breaker located so that it can be easily tripped without coming near any live metal parts and clearly identified as "control power disconnect... oil pump disconnect" or "oil heater disconnect." A preferred location is eye level in the front portion of the enclosure. Any live metal parts on the circuit breaker must be shielded to prevent personal contact.

#### 7.8 VFD Auxiliary Contacts

Install additional normally open or normally closed auxiliary contact(s) from VFD if specified, rated at least 10 amperes at 115 VAC and wired to terminal blocks.

#### 7.9 Watt Transducer

Watt transducer with 4 to 20 mA output proportional to motor KW. Transducer shall be sized for at least 110% of motor KW.

#### 7.10 Modifications to Meet Special Codes

It shall be the manufacturer's responsibility to ascertain the requirements of, and ensure the VFD includes any necessary accessories and/or modifications, in order to comply with any special codes and regulations specified on the order.

#### 7.11 Miscellaneous

##### 7.11.1 Indicating Light

Color red, labeled "run," installed on VFD door, connect in parallel with 1 CR relay coil or energize through an auxiliary contact when VFD is at or above minimum speed.

##### 7.11.2 Start Counter

Mount and wire a 5 or 6 digit counter to increment by one each time an auxiliary contact of 1 CR closes or wire in parallel with 1 CR coil.

##### 7.11.3 Elapsed Time Meter

Install a 6 or more digit elapsed time meter powered from an auxiliary contact of ICR or wired in parallel with the 1 CR coil.