

***This Service Parts Guide Is compiled for the 23XR machine frame#5
Compressor with either frame #3 ,#4 or # 5 coolers & condensers***

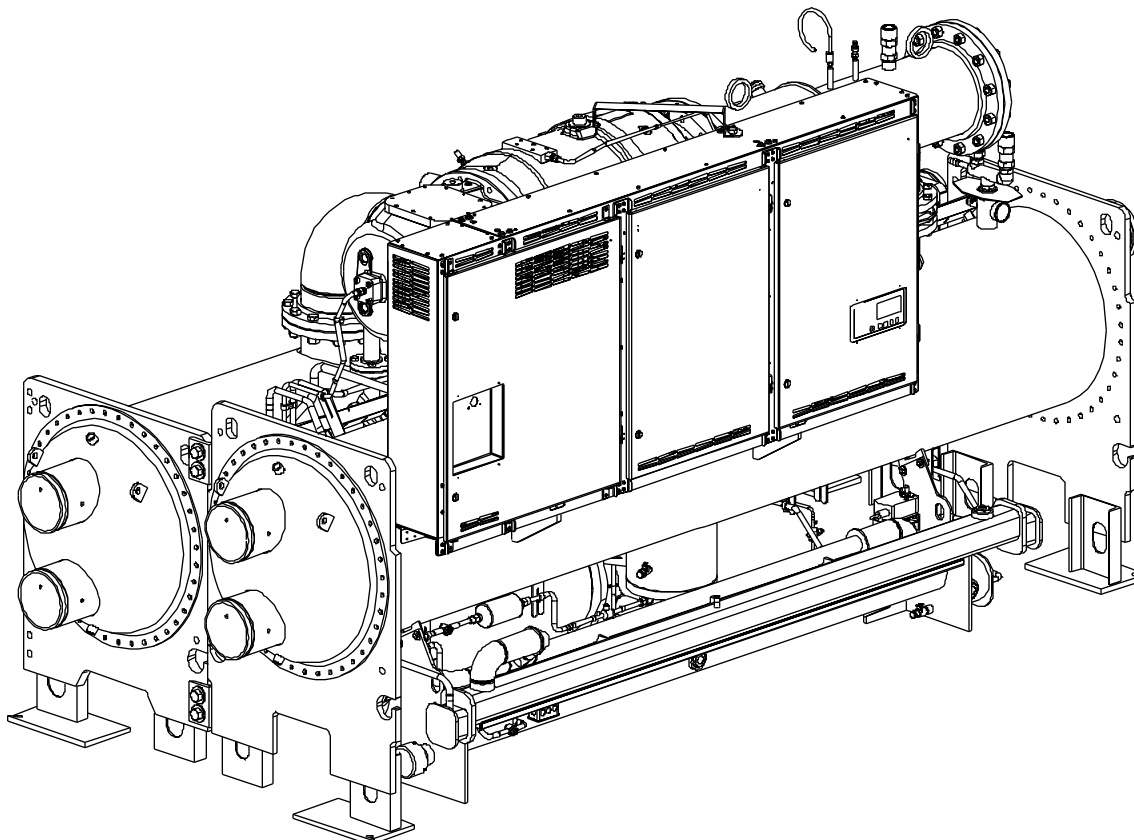

1. This Catalog Presents The Most Commonly Used Specified Parts For The Standard **23XR Hermetic Screw Liquid Refrigeration Machine** And Is Not Applicable To Any Special Order Machines. (Contact Carrier With Machine Serial Number For Any Special Order Machine Service Parts)
2. Occasionally, Due To Limitations Of Illustrations Used, A Part May Not Be Illustrated. These Parts Are Identified By "N" In The Column Next To The Item Number.
3. The Following Parts Are Not Listed In This Catalog:
 - A. Evaporator Tube Part Numbers.
 - B. Condenser Tube Part Numbers.

If Any Of These Parts Are Required Contact Your Carrier (RCD) Representative With Model Number And Serial Number Of Your Machine.

4. Positive Identification Of Your Machine To Properly Select Parts May Be Done By Referring To The Machine Name Plate. See Significance Chart Graphic 23007002.

<u>Date Of Manufacture - Serial Number</u>				
example...1 7 0 6 Q 1 2 3 4 5				
week #17	year 2006	Charlotte	serial number	

MODEL NUMBER SIGNIFICANCE CHART

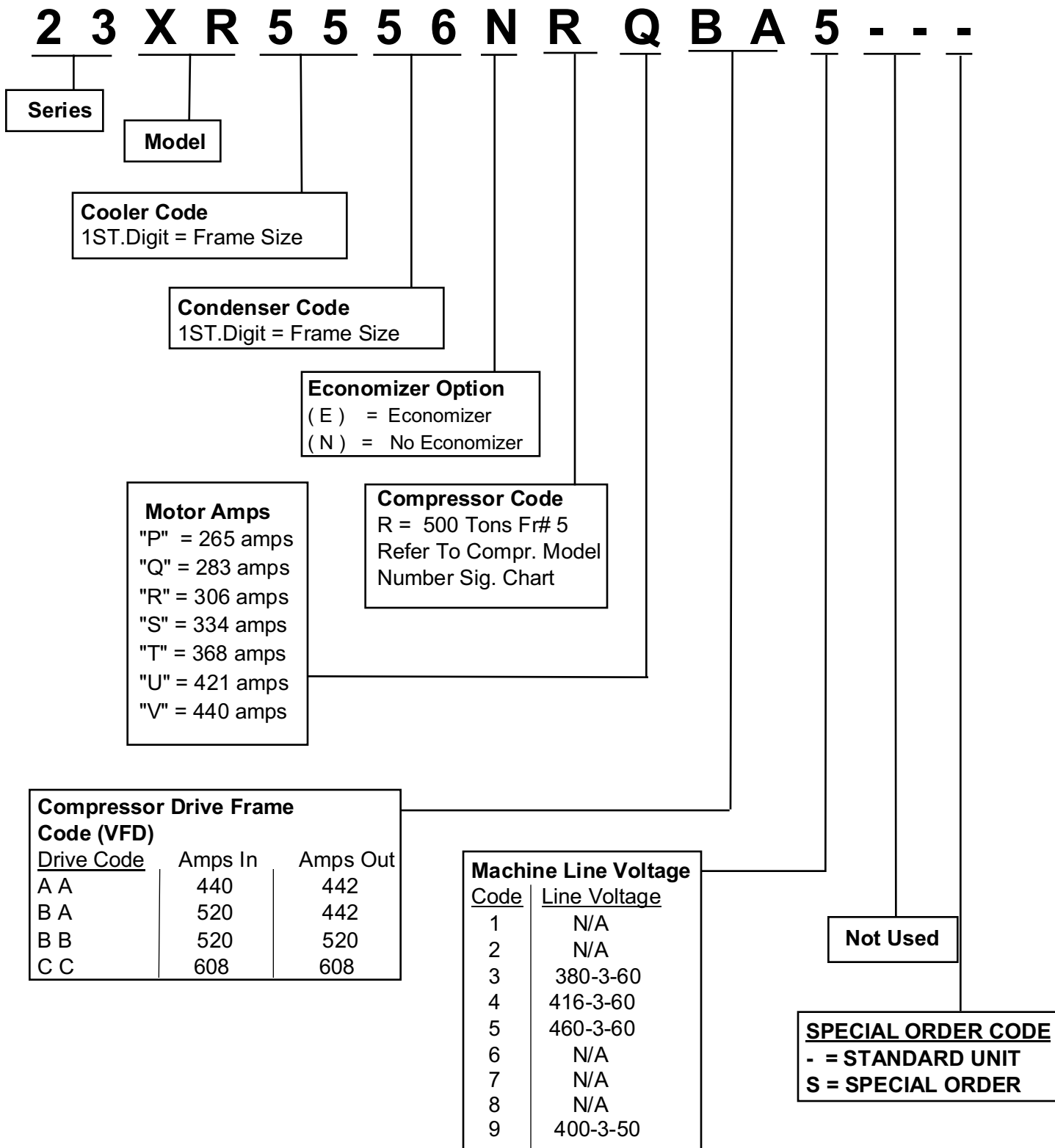

Graphic Pages Table Of Contents

Page 1 (Graphic 23007001).....	Catalog Description
Page 2 (Graphic 23007002).....	Model Number Significance Chart
Page 3 (Graphic 23007003).....	Graphic Pages Table Of Contents
Page 4 (Graphic 23007004).....	Machine Arrangement (w/TR Compr.)
Page 5 (Graphic 23007005).....	Machine Arrangement & Muffler Detail
Page 6 (Graphic 23007006).....	Hot Gas Bypass Line, VFD Cooling Line Float Valve, Vaporizer Vent Line & Bearing Oil Drain Line Details
Page 7 (Graphic 23007007).....	Motor Cooling Line, Vaporizer Hot Gas Line Liquid Refrig. Line, Econ/Compr Gas Refrig. Line
Page 8 (Graphic 23007008).....	Oil Vaporizer Assembly Detail
Page 9 (Graphic 23007009).....	Cooler & Condenser Waterbox Gaskets
Page 10 (Graphic 23007010).....	Cooler & Condenser Waterbox Gaskets
Page 11 (Graphic 23007011).....	Variable Frequency Drive Detail
Page 12 (Graphic 23007012).....	Control Panel Detail
Page 13 (Graphic 23007013).....	"TR" Compressor Details
Page 14 (Graphic 23007014).....	"TR" Compressor Details
Page 15 (Graphic 23007015).....	"TR" Compressor Details
Page 16 (Graphic 23007016).....	"TR" Compressor Details
Page 17 (Graphic 23007017).....	Pumpdown Assembly Detail

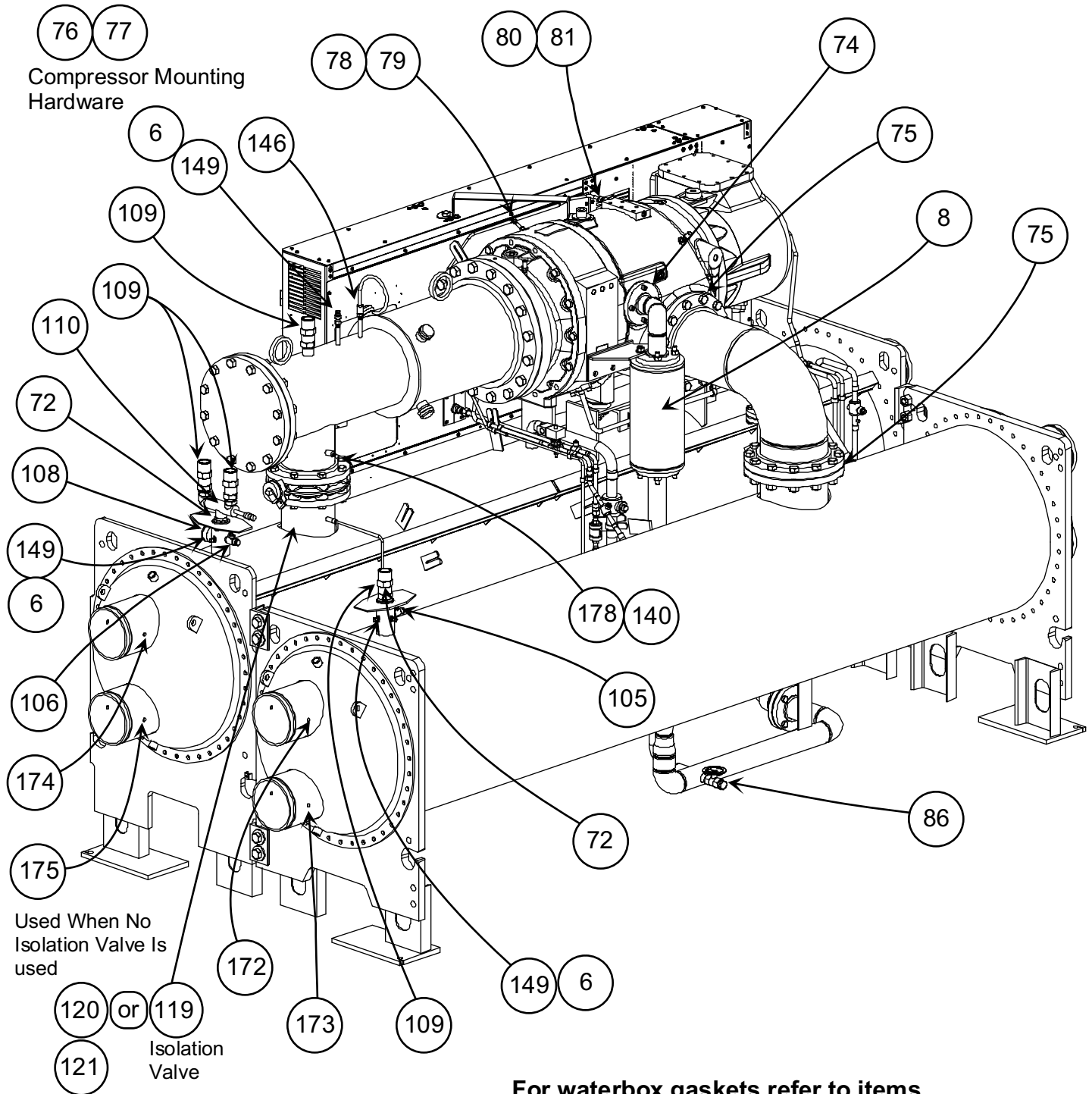

For waterbox gaskets refer to items 132, 133, 134, 135, 136, 137 to determine correct part numbers

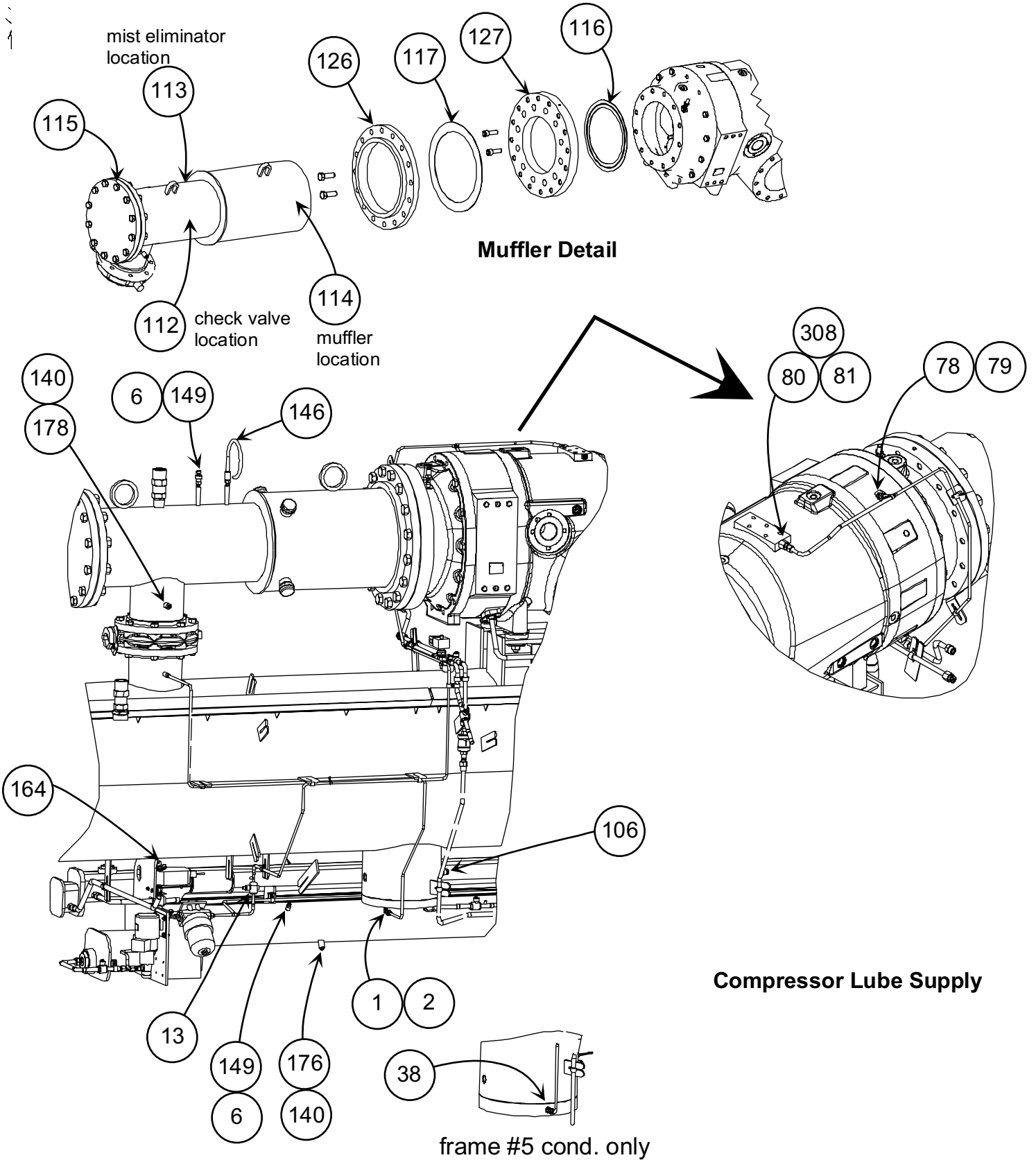

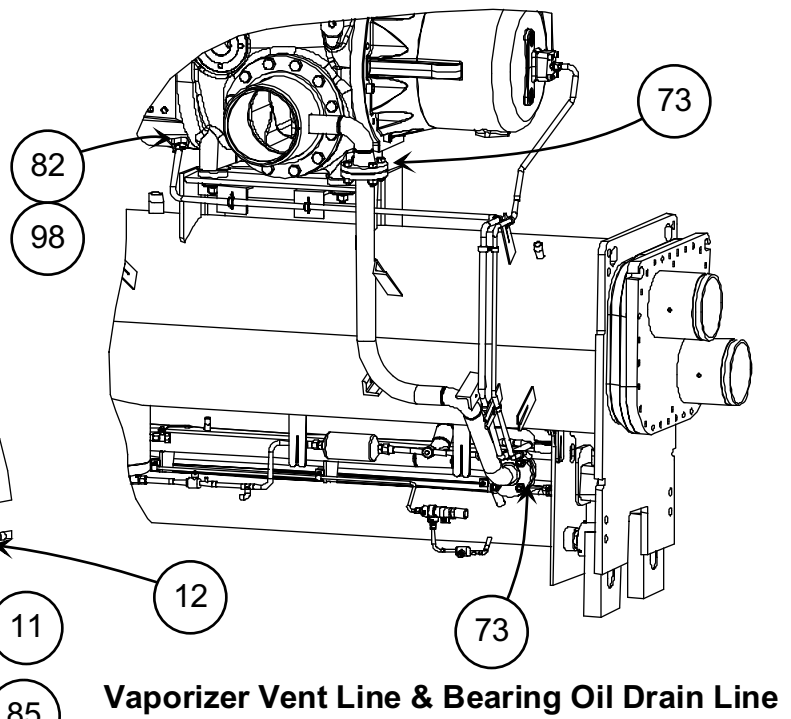
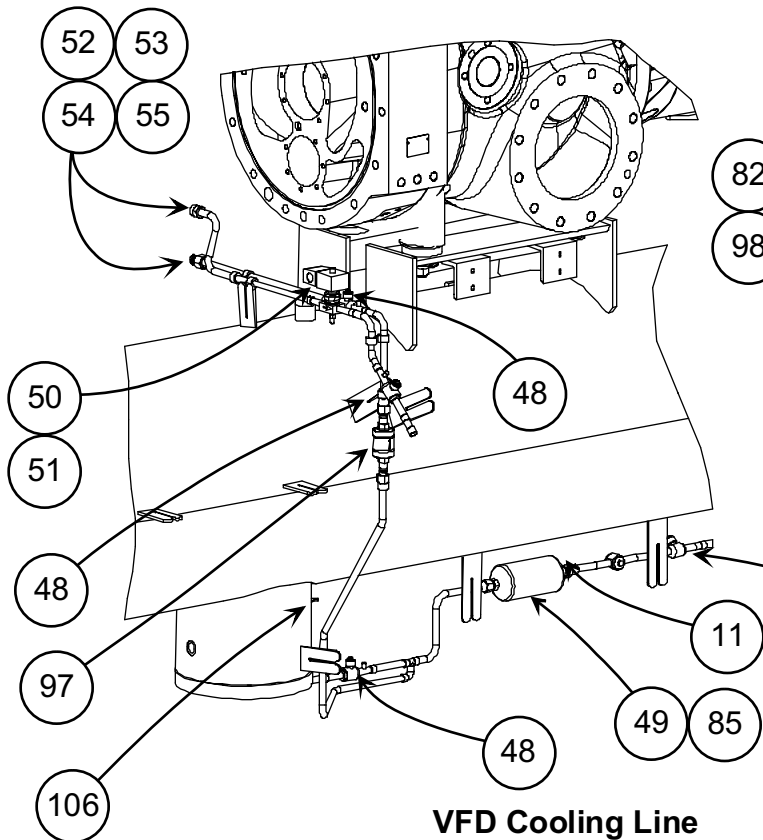
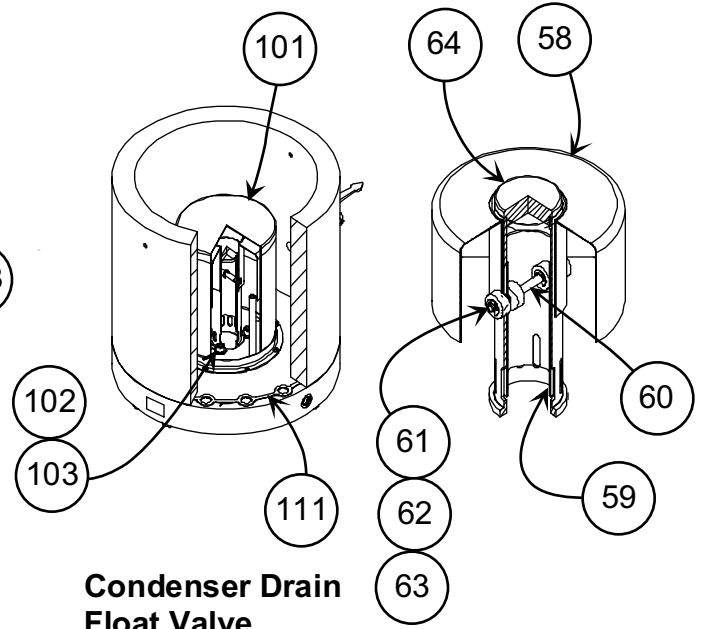
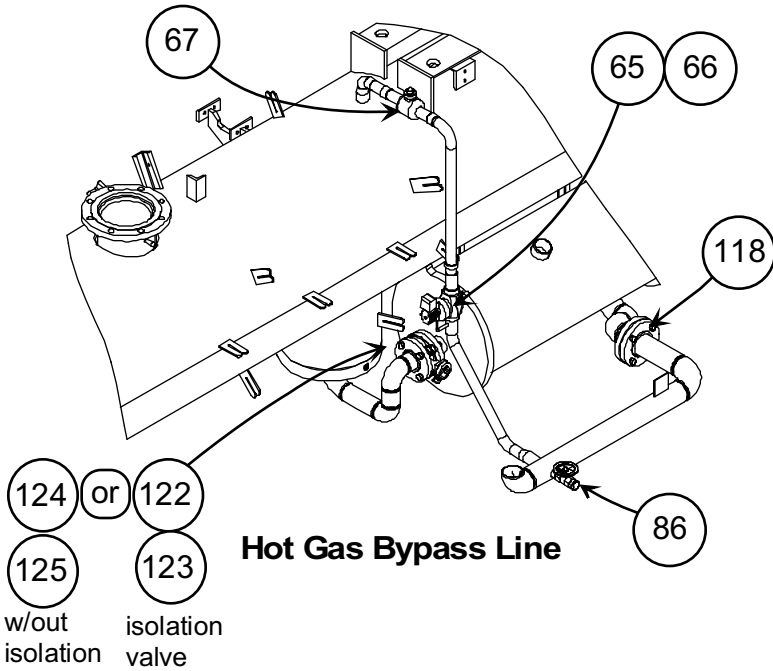

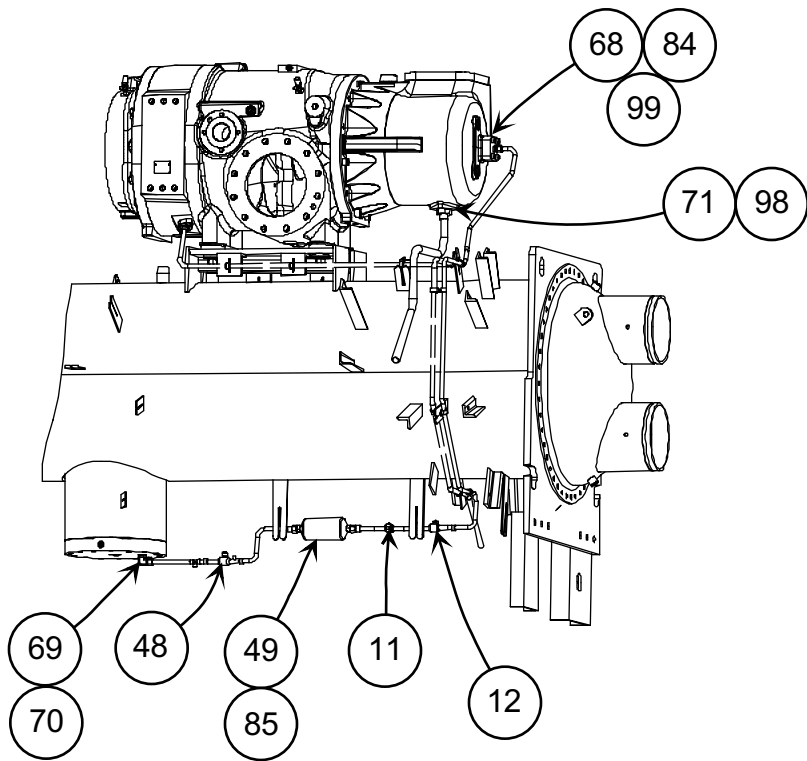

Motor Cooling Line

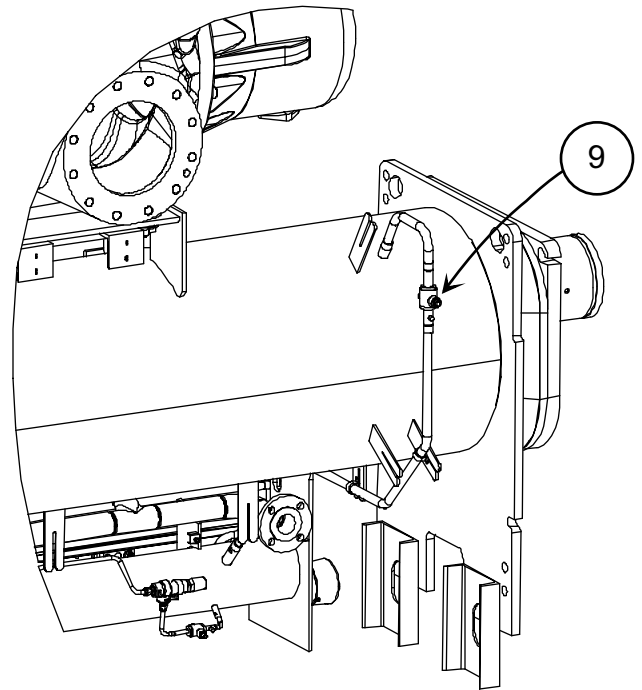

Vaporizer Hot Gas Line

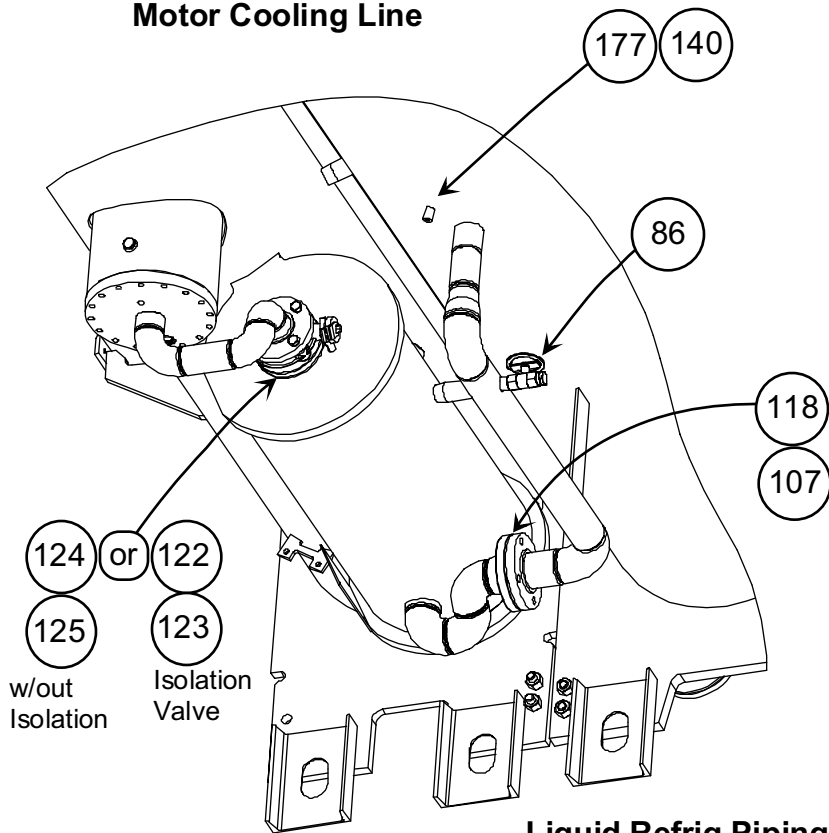

Liquid Refrig Piping

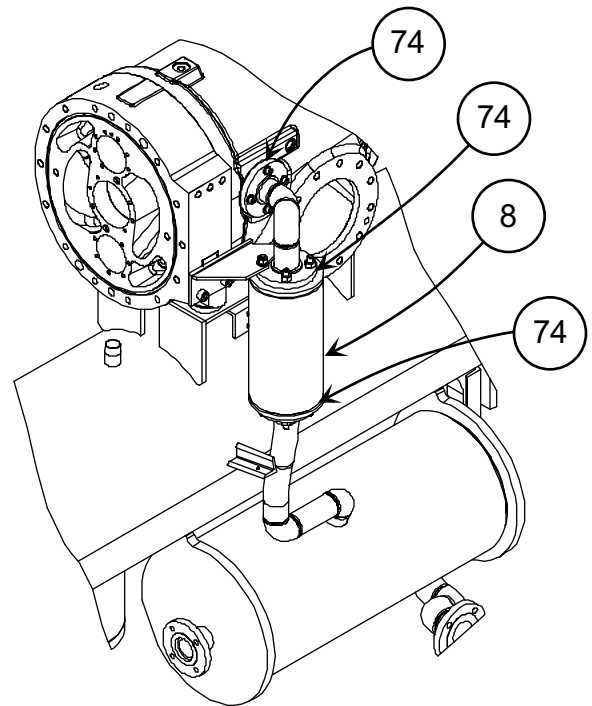

Econ/Compressor Gas Refrig Piping

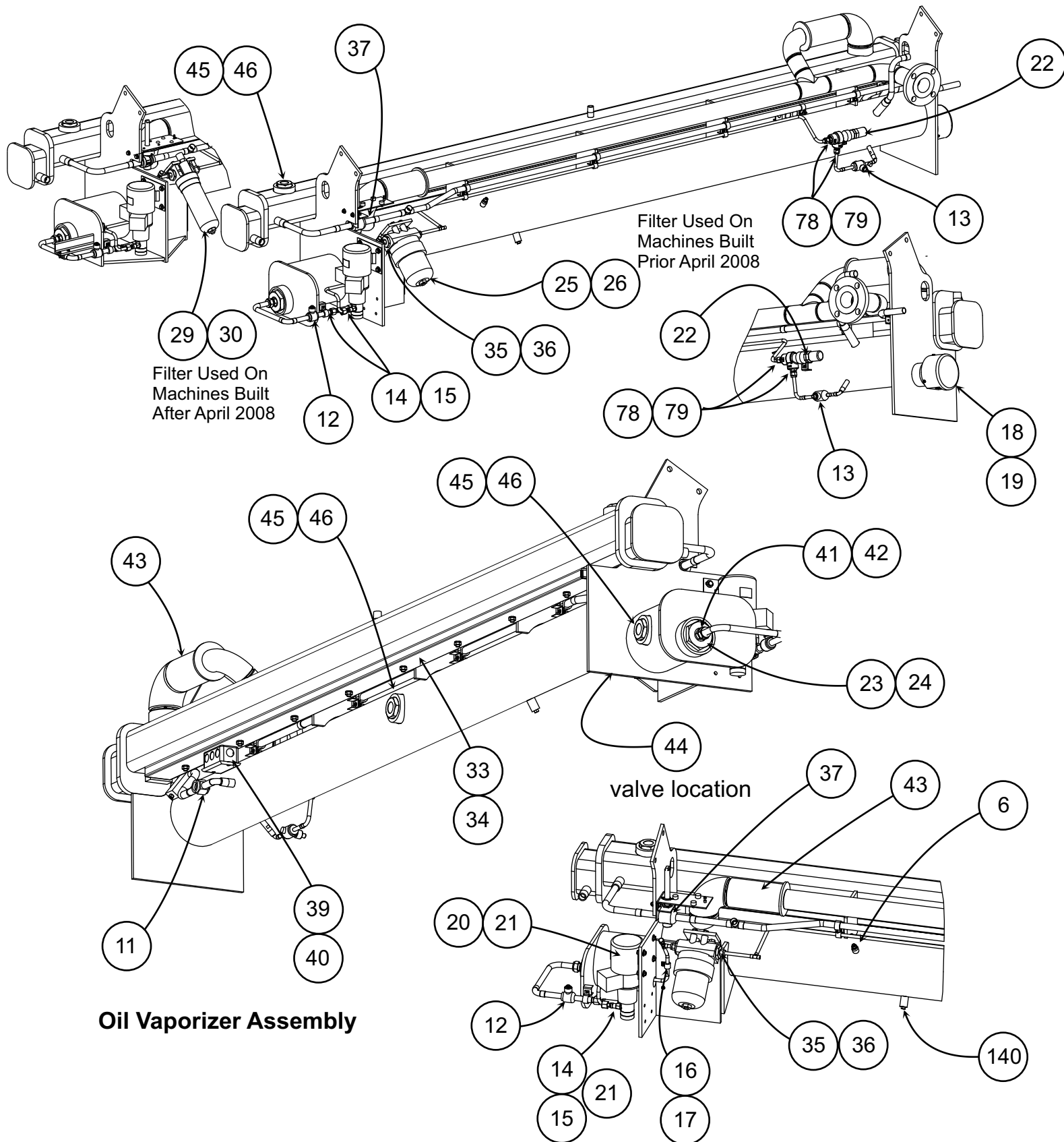

Oil Vaporizer Assembly

Cooler & Condenser Vessel Head & Waterbox Gaskets

- SEE ITEMS
- 132a OR 132d
 - 133a OR 133e
 - 134a OR 134e
- Typical Both Ends

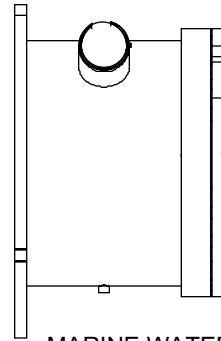
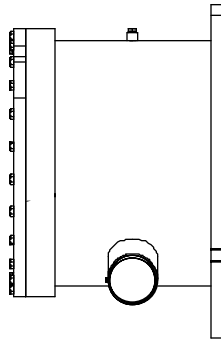

MARINE WATERBOXES
3-PASS

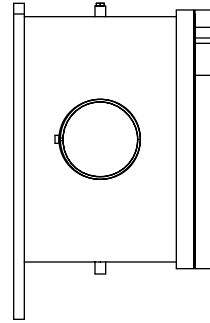
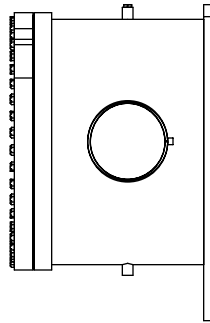

MARINE WATERBOXES
1-PASS

- SEE ITEMS
- 132a OR 132d
 - 133a OR 133e
 - 134a OR 134e
- Typical Both Ends

- SEE ITEMS
- 132c OR 132f
 - 133f
 - 134f
 - 135b OR 135d
 - 136h
 - 137h

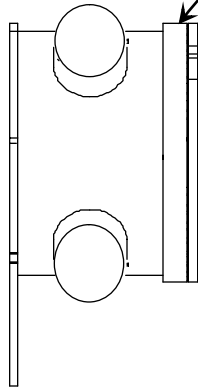

MACHINED HEAD & MARINE WATERBOX
2-PASS

- SEE ITEMS
- 132b OR 132e
 - 133f
 - 134f
 - 135a OR 135c
 - 136g
 - 137g

Cooler & Condenser Vessel Head & Waterbox Gaskets

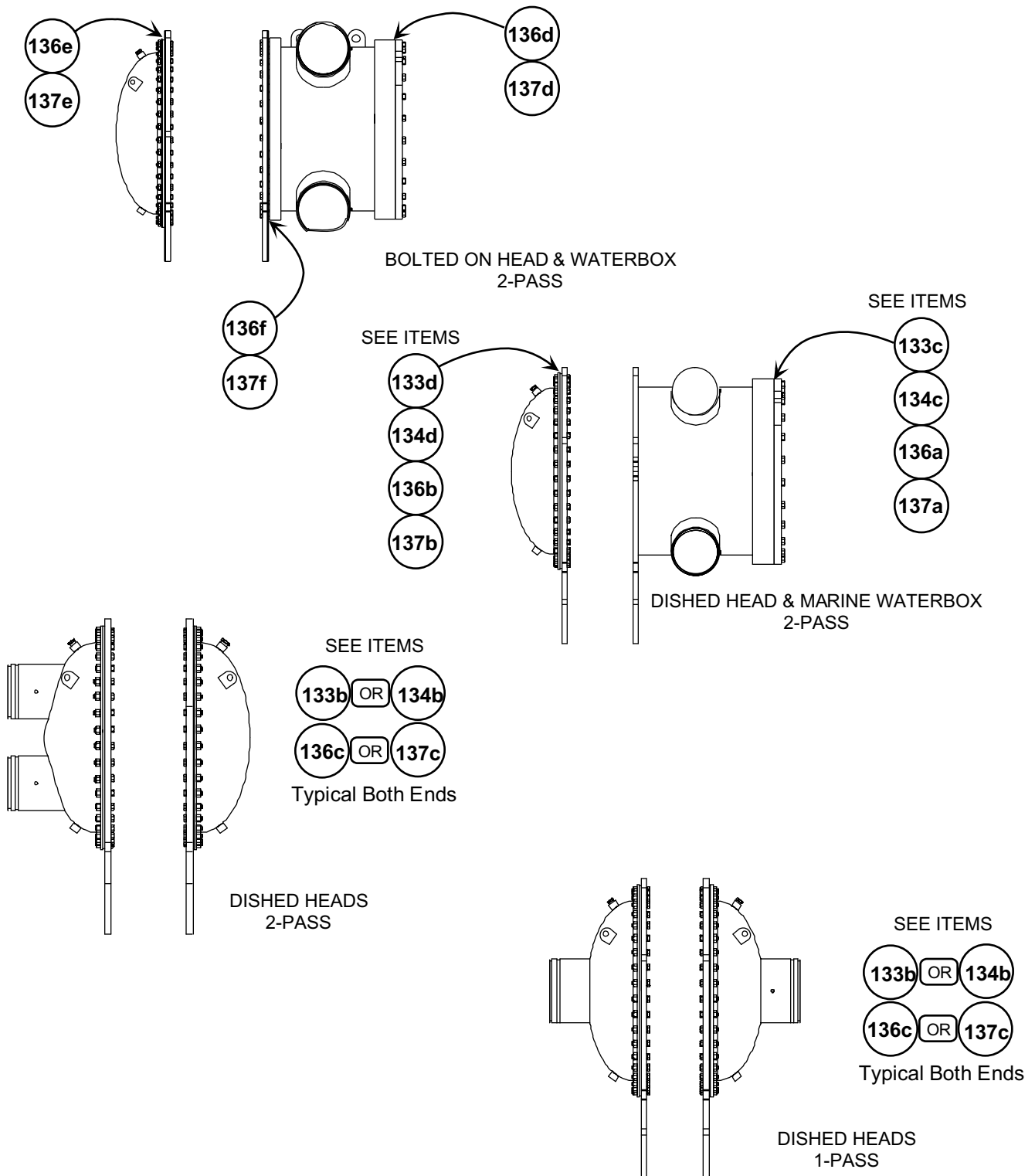

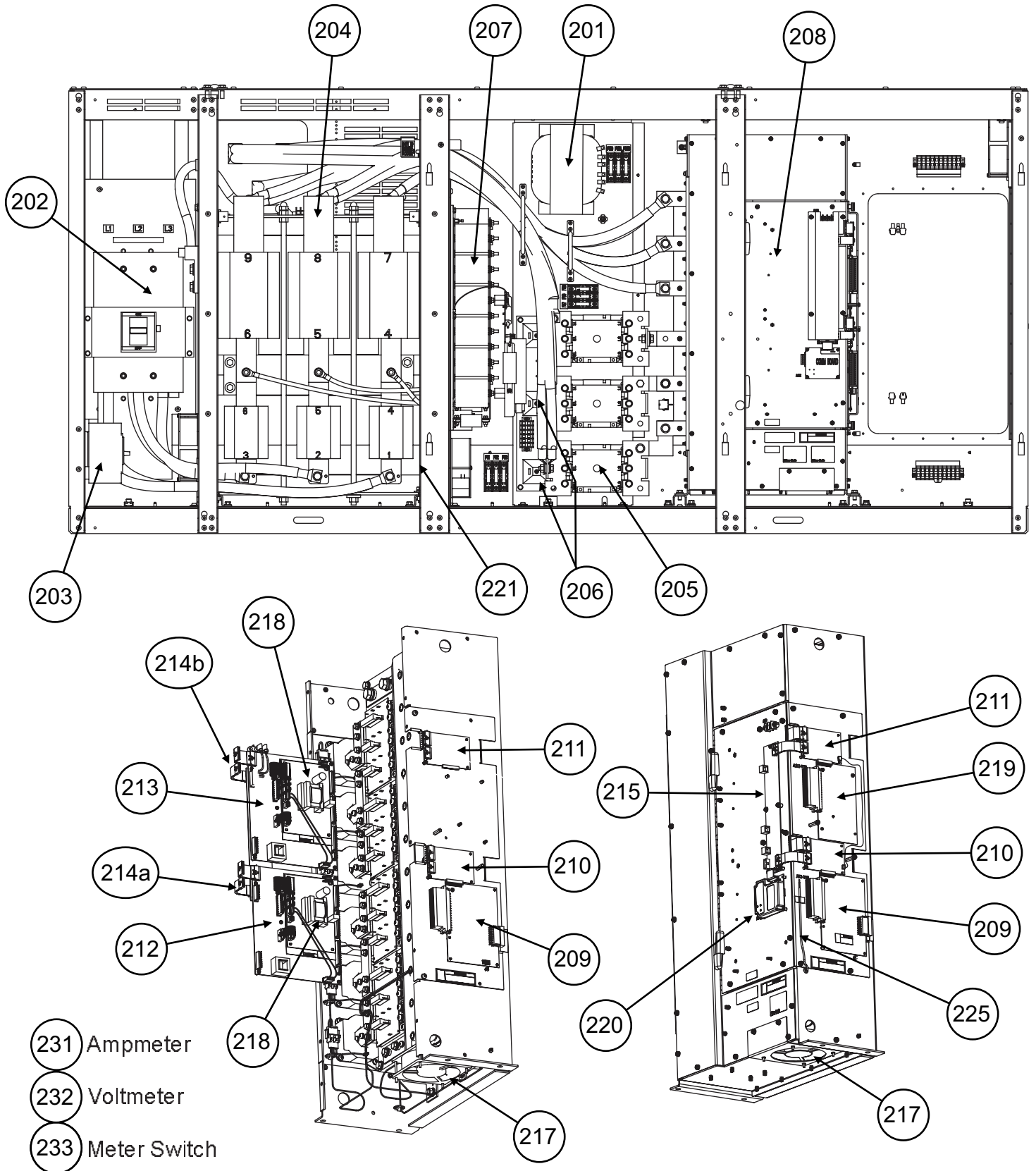

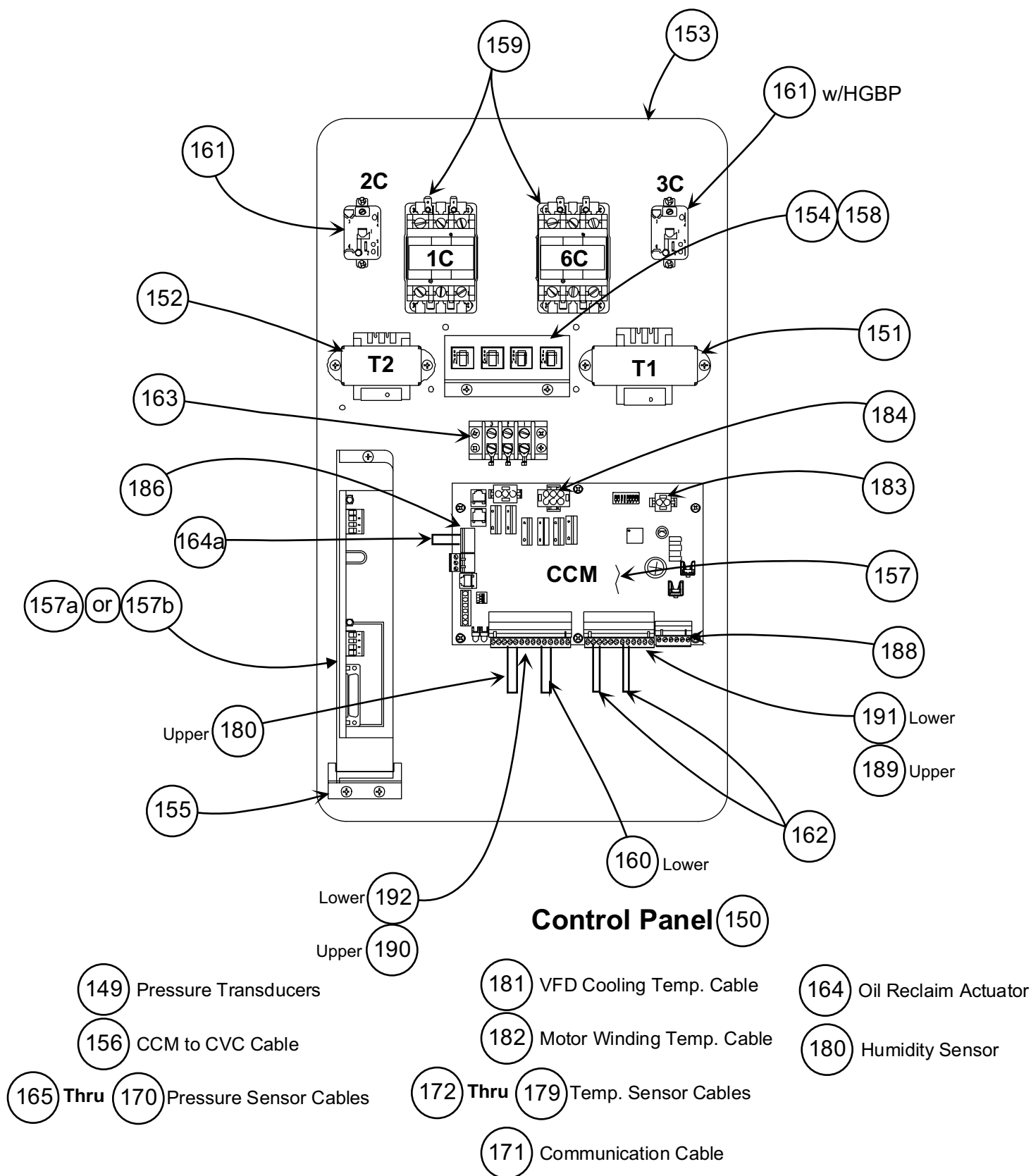

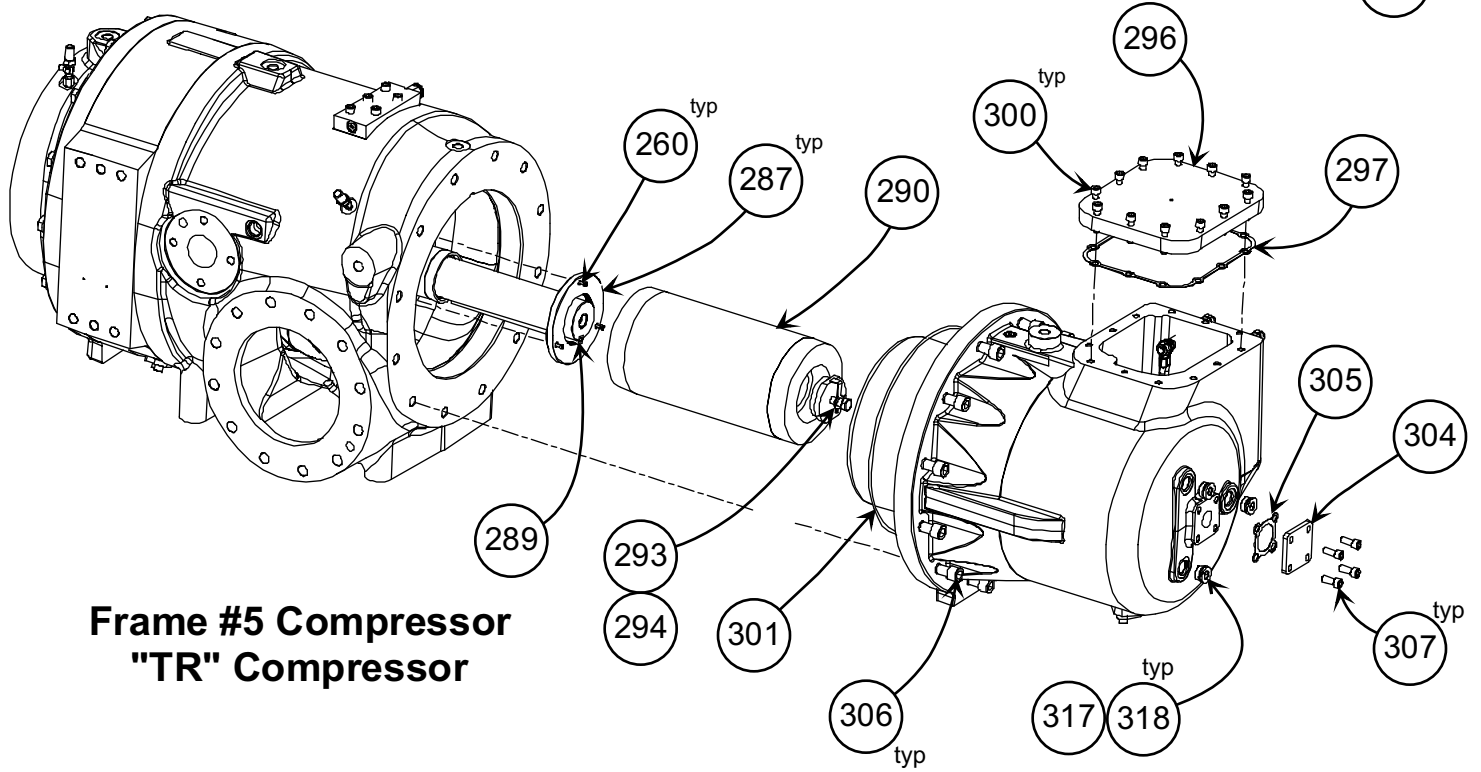
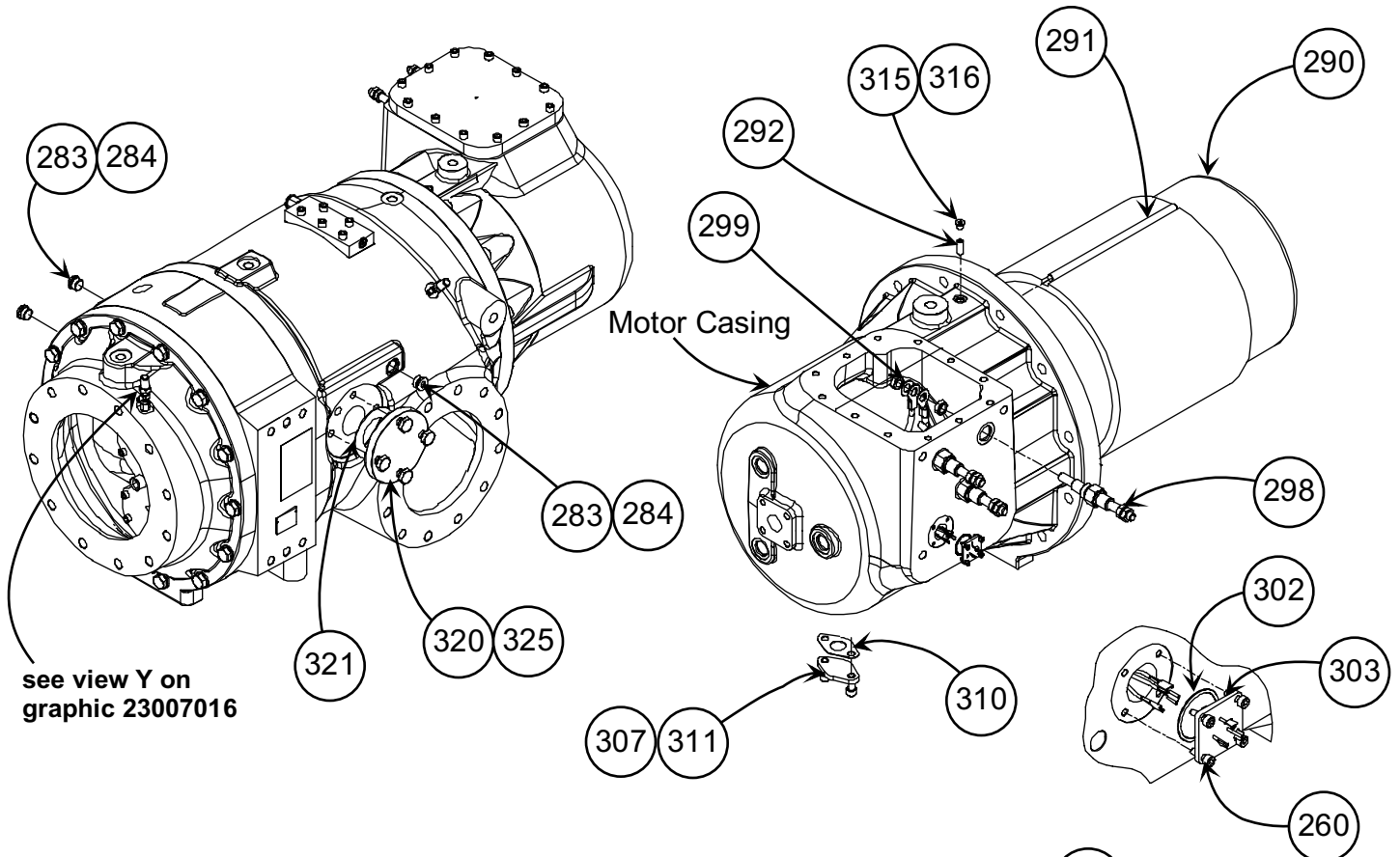

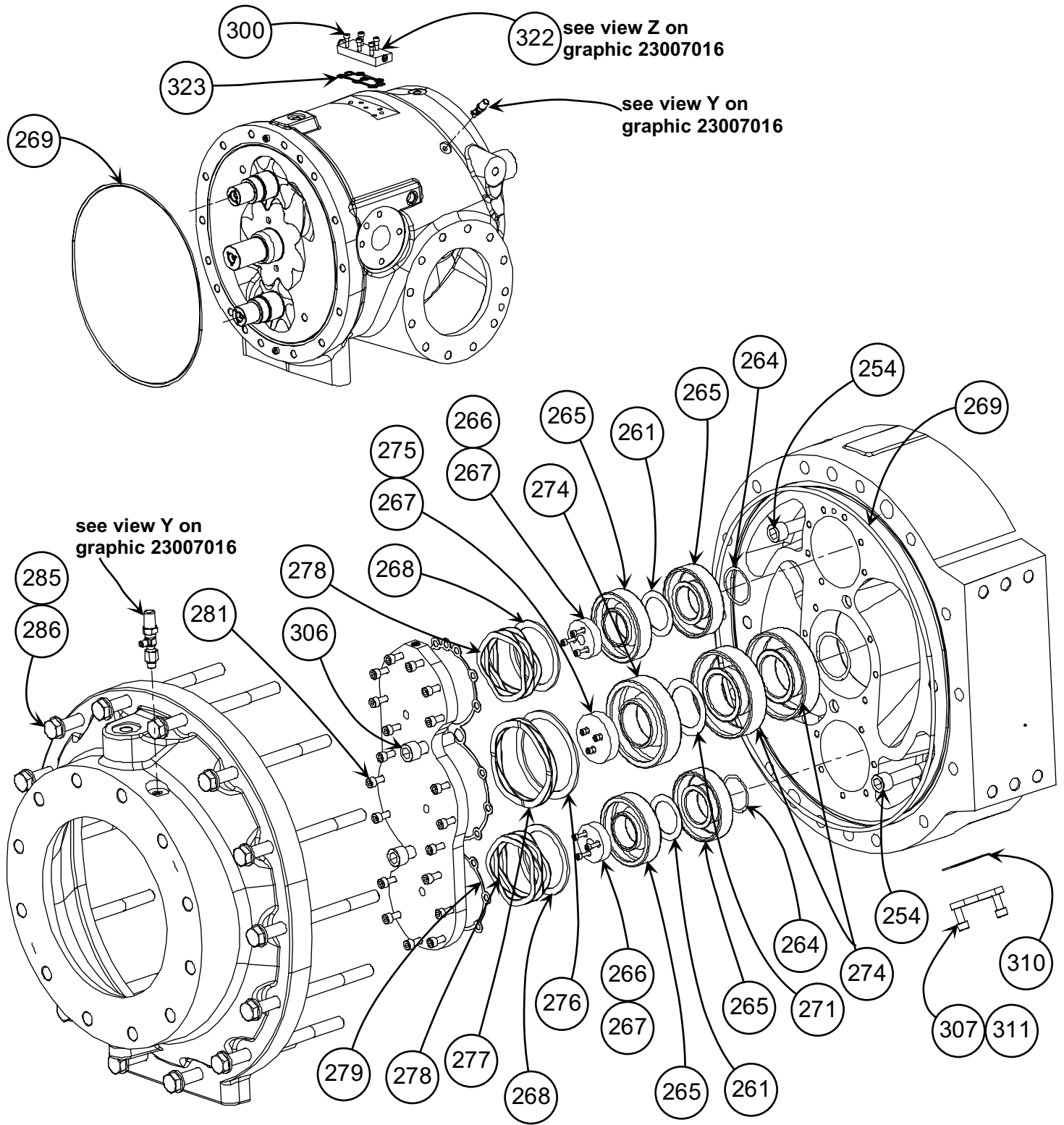

Frame #5 Compressor "TR" Compressor

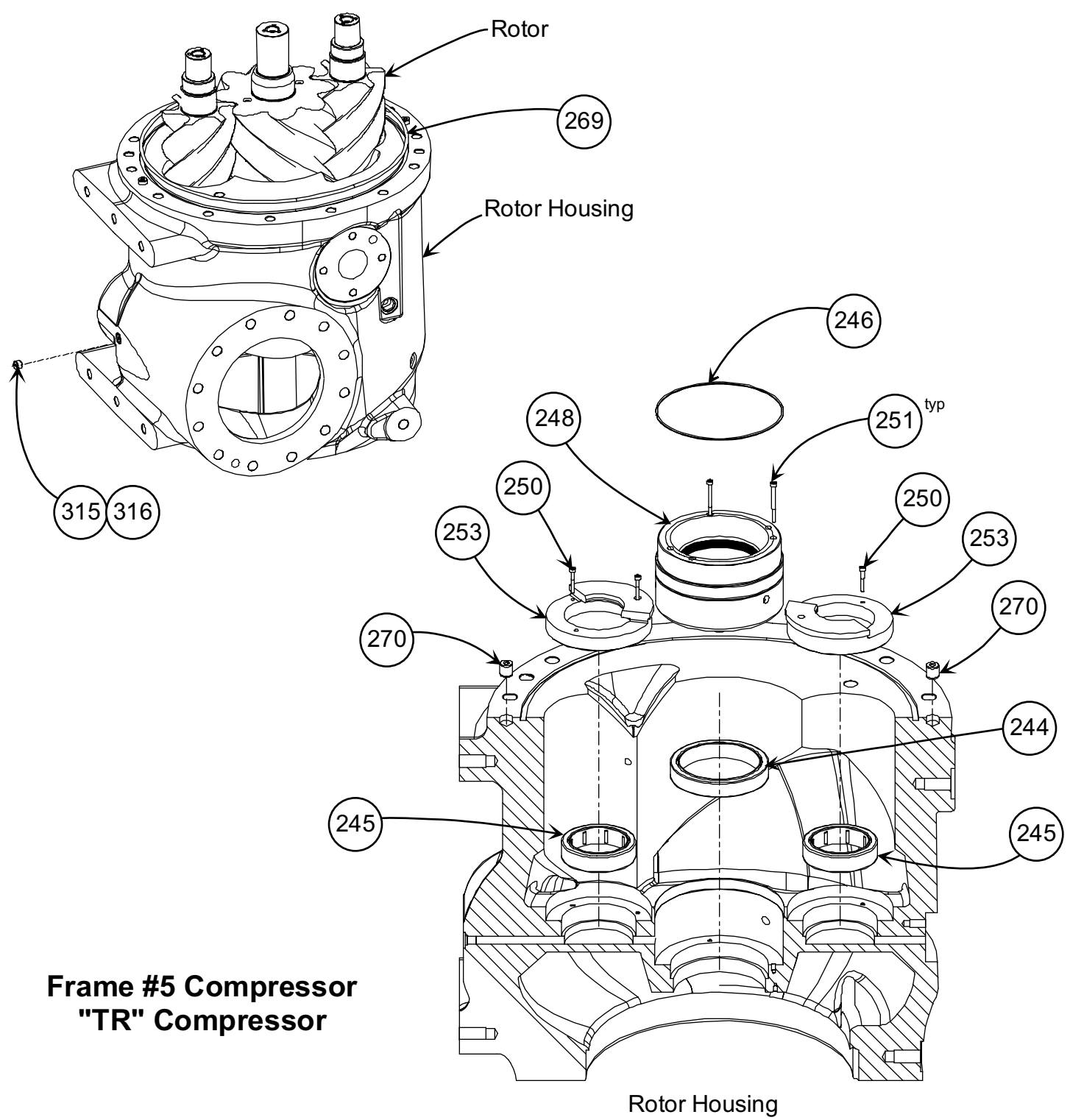

**Frame #5 Compressor
"TR" Compressor**

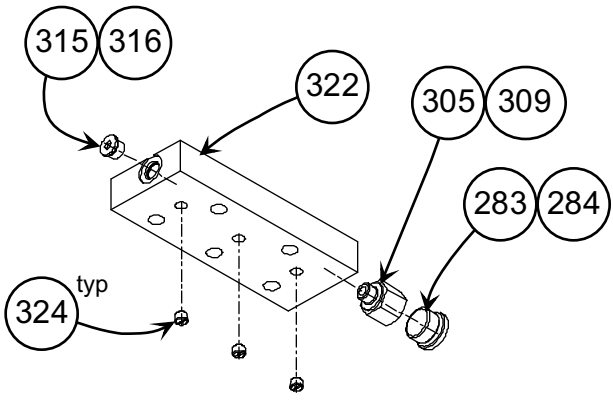
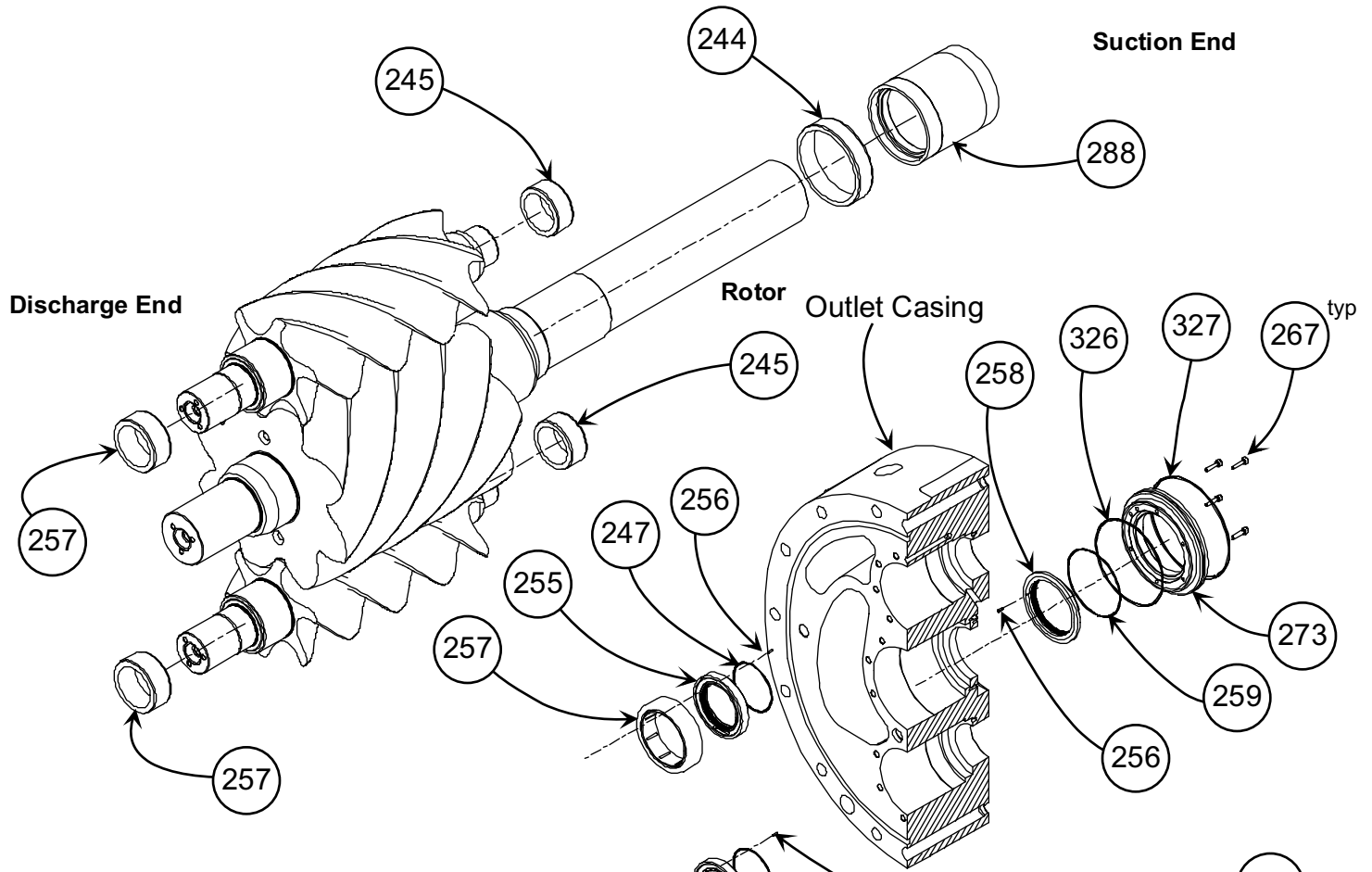

View Z

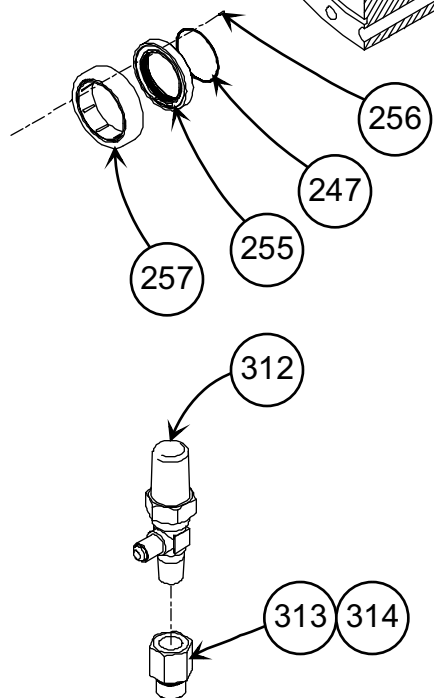

View Y

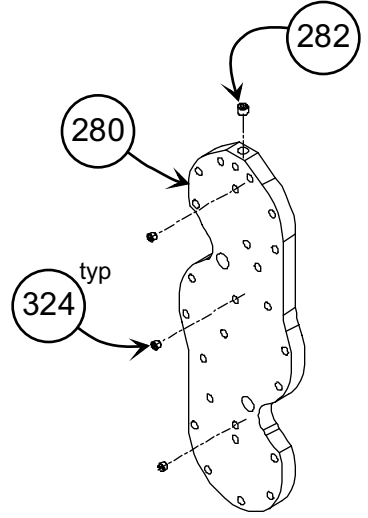

View X

**Frame #5 Compressor
"TR" Compressor**

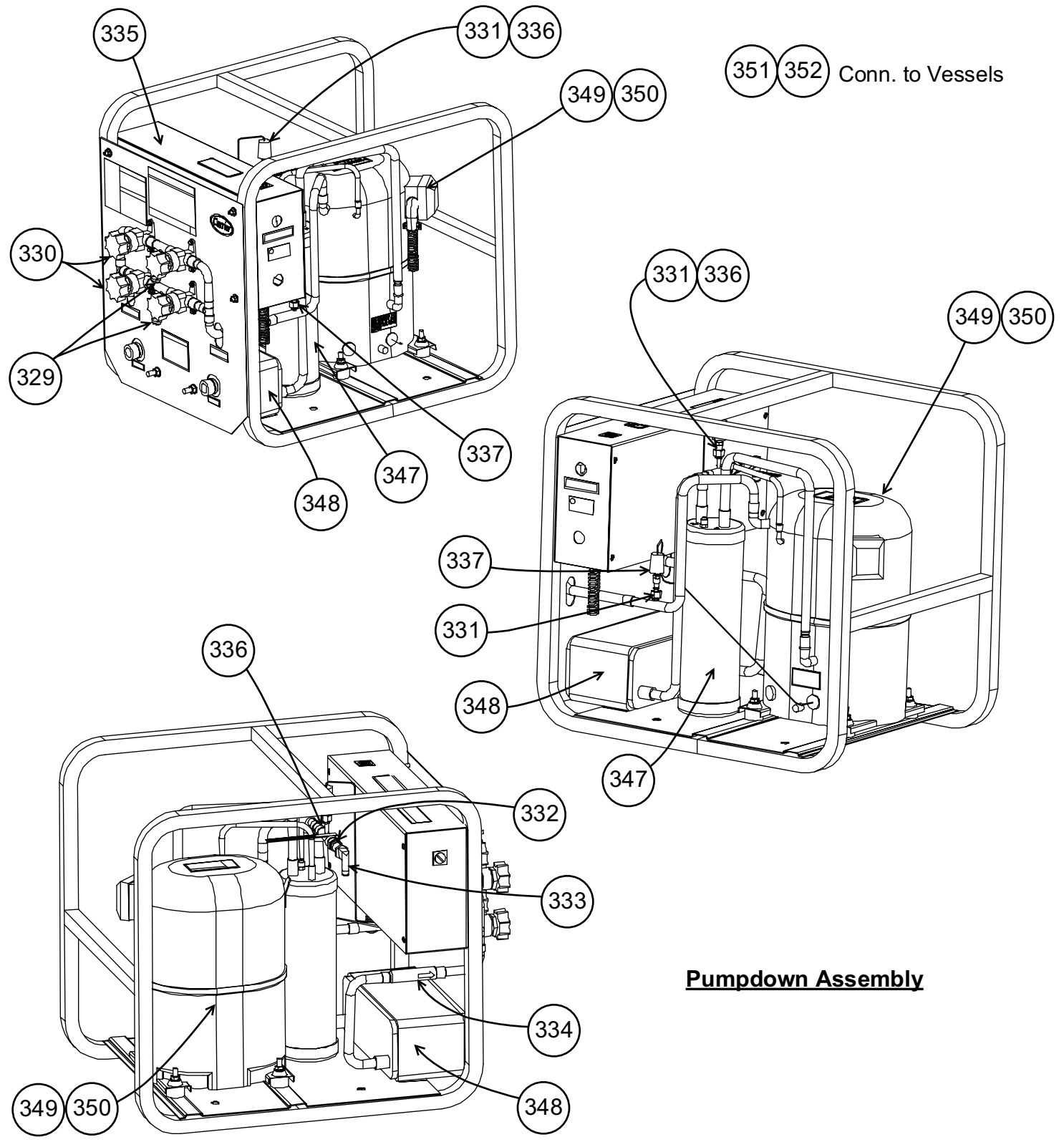

Pumpdown Assembly

Model 23XR

Description HERMETIC SCREW LIQUID CHILLER WITH VARIABLE FREQ. DRIVE, TR COMPR.

Itm#	Qty	Rec	Part Number	Description
1	1	-	02XB05000301	CONNECTOR,STRAIGHT (3/8 X 9/16-18): Includes: Item 2.
2	1	-	KK71EX906	> O-RING (STRAIGHT CONNECTOR)
5	1	-	19XB680001	GASKET,DIVISION PLATE (25' ROLL)
6	5	-	06DA403844	VALVE,SERVICE (SCHRADER)
7	5	-	99CC409372	CAP,FLARE
8	1	-	23XR04010001	MUFFLER ASY (ECONOMIZER GAS)
9	1	-	EP71BA283	VALVE,BALL (7/8)
11	3	-	AMI1SS5	INDICATOR (MOISTURE & LIQUID)
12	3	-	900205	VALVE,BALL (5/8)
13	2	-	EP71BA173	VALVE,BALL (3/8)
14	2	-	DF01CA003	NUT,FITTING
15	2	-	DF02CA005	SLEEVE,FITTING
16	1	-	EC39DM070	VALVE,CHECK
17	1	-	EC39DM072	VALVE,COOLER OIL RECLAIM
18	1	R	23XR05001501	HEATER,OIL: Includes: Item 19.
19	1	-	8TC0288C	> O-RING (OIL HEATER)
20	1	-	23XR05003201	PUMP,OIL: Includes: Item 21.
21	4	-	KK71EW904	> O-RING (OIL PUMP CONNECTIONS)
22	1	-	23XR05023201	VALVE,PRESS. REGULATING
23	1	-	23XR05004501	STRAINER,OIL
24	1	-	KK71EW932	O-RING (STRAINER)
25	1	R	23XR05005601	FILTER HOUSING ASY,OIL: Includes: Items 26 - 27F.
26	1	R	23XR660001	> OIL FILTER KIT (ELEMENT & O-RINGS): Includes: Items 27 - 27F.
27A	1	R	HC9104FKP4PYR19	> > FILTER ELEMENT (REPLACABLE)
27B	1	-	NSS	> > O-RING (HEAD TO BOWL)
27C	1	-	NSS	> > O-RING (FILTER ELEMENT)
27D	1	-	NSS	> > O-RING (DIFF. PORT PLUG)
27E	1	-	NSS	> > O-RING (VENT PORT)
27F	1	-	NSS	> > O-RING (DRAIN)
29	1	-	23XR05026201	FILTER HOUSING ASY,OIL
30	1	-	23XR660003	> OIL FILTER KIT (ELEMENT & O-RINGS)
31A	1	-	NSS	> > FILTER ELEMENT (REPLACABLE)
31B	1	-	NSS	> > O-RING (HEAD TO BOWL)
31C	1	-	NSS	> > O-RING (FILTER ELEMENT)
31D	1	-	NSS	> > O-RING (DRAIN)
33	1	R	23XR05009901	HEATER,OIL (OIL VAPORIZER)
34	1	-	23XR05012001	COVER,HEATER
35	2	-	23XR05005701	CONNECTOR,STRAIGHT (1-5/16-12): Includes: Item 36.
36	1	-	KK71EW916	> O-RING (STRAIGHT CONNECTOR)
37A	1	-	23XR05006301	VALVE,OIL RECLAIM (SEE NOTE): Note: used on machines build prior to October 2007. when NLA item 37B may be used with minimal piping changes.
37B	1	-	23XR04008401	VALVE,OIL RECLAIM (SEE NOTE): Note: used on machines build after October 2007.
38	2	-	DD07DA101	COUPLING,UNION (3/8)
39	1	-	HX08FZ050	COVER, EXT BOX
40	1	-	HX22FS036	BOX, EXT RING
41	1	-	DC80SA020	CONNECTOR,STRAIGHT (5/8 X 7/8-14): Includes: Item 42.
42	1	-	KK71EW910	> O-RING (STRAIGHT CONNECTOR)
43	1	-	23XR55010101	ELIMINATOR,MESH
44	1	-	EP23LA211	VALVE,ANGLE (1/2)
45	3	-	KM36BS162	SIGHT GLASS: Includes: Item 46.

Itm#	Qty	Rec	Part Number	Description
46	1	-	8TC0288C	> O-RING (SIGHT GLASS)
48	3	-	EP71BA211	VALVE,BALL (5/8)
49	1	R	KH45LE120	DRIER,FILTER (MOTOR COOLING)
50	1	-	23XR05006601	VALVE ASY,SOLENOID (VFD RETURN): Includes: Item 51.
51	1	R	EF19XS026	> COIL,SOLENOID (24V)
52	2	-	KK71EW016	O-RING (VFD TO MACHINE CONN.)
53	2	-	DF34CA019	CONNECTOR (VFD TO MACHINE CONN.)
54	2	-	DF01CA007	NUT,BRASS (VFD TO MACHINE CONN.)
55	2	-	DF02CA025	SLEEVE,FITTING (VFD TO MACHINE CONN.)
57	1	-	09XR04005305	VALVE ASY,FLOAT (ECON. & COND. DRAIN): Includes: Items 58 - 64.
58	1	-	09XR04005101	> FLOAT ASY
59	1	-	09XR05012704	> SLEEVE ASY
60	2	-	09XR05013201	> SPACER,FLOAT SLEEVE
61	1	-	09XR05013001	> SHAFT,FLOAT VALVE
62	2	-	09XR05011301	> BEARING,FLOAT VALVE
63	3	-	AU45AZ025	> RETAINING RING
64	1	-	09XR05013301	> END CAP
65	1	-	EF28BS451	VALVE,SOLENOID (HOT GAS BY-PASS): Includes: Item 66.
66	1	R	KS-E42	> REBUILD KIT,SOLENOID (HGBP VALVE)
67A	1	-	EP71BA471	VALVE,BALL (1-5/8)(HGBP)(FR# 3 COND)
67B	1	-	900613	VALVE,BALL (1-5/8)(HGBP)(FR# 4/5 COND)
68	1	-	23XR54002901	SPRAY ASY (MOTOR COOLING)
69	1	-	DC83SA025	FITTING,ELBOW (5/8 X 7/8-14): Includes: Item 70.
70	1	-	KK71EW912	> O-RING,COMPRESSION ELBOW FITTING
71	1	-	DK24CA717	FLANGE,O-RING (MOTOR DRAIN)
72	2	-	CA53AA424	BUSHING,REDUCER (2 MPT X 1 FPT)
73	2	-	CT99QX401	GASKET,RING (2") (VAPOR. VENT LINE)
74	3	-	CR90YA451	GASKET,RING (2-1/2")(ECON/COMPR.)
75	2	-	CT99QN851	GASKET,RING (10")(COOLER/COMPR.)
76	4	-	23XR04000201	MOUNT ASY,COMPRESSOR
77	4	-	23XR05000601	ROD,THREADED (COMPR. MOUNTING)
78	4	-	DC80SA005	CONNECTOR,STRAIGHT (3/8 X 9/16-18): Includes: Item 78.
79	1	-	KK71EX906	> O-RING (STRAIGHT CONNECTOR)
80	1	-	DC80SA010	CONNECTOR,STRAIGHT (1/2 X 3/4-16): Includes: Item 81.
81	1	-	KK71EW908	> O-RING (STRAIGHT CONNECTOR)
82	1	-	23XR05018601	FLANGE,O-RING (BEARING OIL DRAIN)
83	5	-	19EF501-1212	WELL,SENSOR
84	1	-	DC09SA307	CONNECTOR,STRAIGHT
85	10	-	P806-N4-4	NUT,FLARE (5/8)
86	1	-	EP71CQ306	VALVE,BALL (1)
87	4	-	KA66AA038	CLAMP,TUBE (W/CUSHION) (3/8)
88	9	-	KA66AA062	CLAMP,TUBE (W/CUSHION) (5/8)
89	6	-	KA66AA075	CLAMP,TUBE (W/CUSHION) (3/4)
90	3	-	KA66AA138	CLAMP,TUBE (1-3/8)
91	1	-	KA66AA154	CLAMP,TUBE (W/CUSHION) (1-5/8)
92	1	-	KA66FB159	CLAMP,TUBE (W/CUSHION) (1-5/8)
93	1	-	KA66FB214	CLAMP,TUBE (W/CUSHION) (2-1/8)
94	1	-	KA66AA113	CLAMP,TUBE (W/CUSHION) (1-1/8)
95	1	-	KA66FB063	CLAMP,TUBE (5/8)
96	2	-	KA66RA044	CLAMP,TUBE (PLASTIC) (7/16) (ICVC)
97	1	R	KH11NG120	STRAINER,REFRIGERANT
98	2	-	KK71EW223	O-RING (1-5/8 ID)
99	1	-	KK71EW229	O-RING (2-5/16 ID)
100A	1	-	09XB45001901	GASKET,RING (COND. FLT VALVE ACCESS): Note: Used on frame #3 & frame #4 condenser float valves only.

Itm#	Qty	Rec	Part Number	Description
100B	1	-	09XR05002001	GASKET,RING (COND. FLT VALVE ACCESS): Note: Used on frame #5 condenser float valves only.
101	1	-	09XB04000901	SCREEN ASY (COND. FLOAT VALVE)
102	3	-	AA44AA226	SCREW
103	3	-	AU04AV241	WASHER
104	1	-	09XB15002601	GASKET
105	1	-	EP71CQ182	VALVE,BALL (1/2) (COOLER SERVICE)
106A	1	-	EP71CQ182	VALVE,BALL (1/2) (CONDENSER SERVICE): Note: Used on frame #3 & frame #5 condensers only.
106B	1	-	EP71CZ182	VALVE,BALL (1/2) (CONDENSER SERVICE): Note: Used on frame #4 condensers only.
107	1	-	23XR05014501	PLATE,ORIFICE (ECONOMIZER)
108	1	R	KM03AC256	GAUGE,PRESSURE (COND.)
109	4	-	19EB660005	VALVE,RELIEF (1-1/4) (COND,MUFFLER,COOL)
110	2	-	8024	VALVE,SHUT-OFF (1" 3-WAY) (COND.)
111	1	-	23XR54009301	MUFFLER ASSEMBLY (REFERENCE ONLY)
112	1	-	23XR04014101	> VALVE,CHECK (DISCHARGE MUFFLER)
113	1	-	23XR05010301	> ELIMINATOR,MIST
114	1	-	23XR54009401	> MUFFLER
115	1	-	CT99QN951	> GASKET,RING (12") (MUFFLER)
116	1	-	19Q143251LA	GASKET,RING (12") (MUFFLER)
117	1	-	17FA241-1052LA	GASKET,RING (16") (MUFFLER)
118	2	-	CT99QX501	GASKET,RING (3")
119	1	-	19XR05016408	VALVE,DISCHARGE ISOLATION: Note: no gaskets are required to seal this valve.
120	2	-	CT99QN801	GASKET,RING (8") (NO ISOLATION VALVE)
121	1	-	19XR45003401	SPACER,DISCHARGE (NO ISOLATION VALVE)
122	1	-	19XR05016409	VALVE,COOLER ISOLATION (2-1/2): Includes: Item 123.
123	2	-	PARTOFVALVE	> O-RING,VALVE
124	1	-	23XR05016501	SPACER,COOLER INLET (NO ISOL. VALVE)
125	2	-	CT99QX501	GASKET,RING (3") (NO ISOL. VALVE)
126	1	-	CT50EA911	FLANGE,SLIPON (16") (FLAT FACED)
127	1	-	23XR05007701	FLANGE,ADAPTER (12" X 16")
132	1	-	SEENOTESFORUSAGE	FRAME #3 COOLER WATERBOX GASKETS
132A	2	-	10XR35001001	GASKET,WATERBOX 150 PSI (FR#3): Note: Used on 1 and 3 pass frame #3 coolers w/marine W/B, both ends.
132B	1	-	10XR35001001	GASKET,WATERBOX 150 PSI (FR#3): Note: Used on 2 pass frame #3 coolers, marine W/B end only.
132C	1	-	10XR35000201	GASKET,WATERBOX 150 PSI (FR#3): Note: Used on 2 pass frame #3 coolers, blank end only.
132D	2	-	10XR35001101	GASKET,WATERBOX 300 PSI (FR#3): Note: Used on 1 and 3 pass frame #3 coolers w/marine W/B, both ends.
132E	1	-	10XR35001101	GASKET,WATERBOX 300 PSI (FR#3): Note: Used on 2 pass frame #3 coolers, marine W/B end only.
132F	1	-	09XB55009101	GASKET,WATERBOX 300 PSI (FR#3): Note: Used on 2 pass frame #3 coolers, blank end only.
133	1	-	SEENOTESFORUSAGE	FRAME #4 COOLER WATERBOX GASKETS
133A	2	-	09XR45000801	GASKET,WATERBOX 150 PSI (FR#4): Note: Used on 1 and 3 pass frame #4 coolers w/marine W/B, both ends.
133B	2	-	09XR05007001	GASKET,WATERBOX 150 PSI (FR#4): Note: Used on 1 and 2 pass frame #4 coolers w/dished heads,both ends.
133C	1	-	09XR45000801	GASKET,WATERBOX 150 PSI (FR#4): Note: Used on 2 pass frame #4 coolers, marine W/B end only.
133D	1	-	09XR05007001	GASKET,WATERBOX 150 PSI (FR#4): Note: Used on 2 pass frame #4 coolers, dished head end only.
133E	2	-	09XR45001001	GASKET,WATERBOX 300 PSI (FR#4): Note: Used on 1 and 3 pass frame #4 coolers w/marine W/B, both ends.
133F	2	-	09XR45001001	GASKET,WATERBOX 300 PSI (FR#4): Note: Used on 2 pass frame #4 coolers,marine W/B and blank end.
134	1	-	SEENOTESFORUSAGE	FRAME #5 COOLER WATERBOX GASKETS
134A	2	-	09XR55000801	GASKET,WATERBOX 150 PSI (FR#5): Note: Used on 1 and 3 pass frame #5 coolers w/marine W/B, both ends.
134B	2	-	09XR05007002	GASKET,WATERBOX 150 PSI (FR#5): Note: Used on 1 and 2 pass frame #5 coolers w/dished heads,both ends.

Itm#	Qty	Rec	Part Number	Description
134C	1	-	09XR55000801	GASKET,WATERBOX 150 PSI (FR#5): Note: Used on 2 pass frame #5 coolers, marine W/B end only.
134D	1	-	09XR05007002	GASKET,WATERBOX 150 PSI (FR#5): Note: Used on 2 pass frame #5 coolers, dished head end only.
134E	2	-	09XR55001001	GASKET,WATERBOX 300 PSI (FR#5): Note: Used on 1 and 3 pass frame #5 coolers w/marine W/B, both ends.
134F	2	-	09XR55001001	GASKET,WATERBOX 300 PSI (FR#5): Note: Used on 2 pass frame #5 coolers,marine W/B and blank end.
135	1	-	SEENOTESFORUSAGE	FRAME #3 CONDENSOR WATERBOX GASKETS
135A	1	-	09XR35001001	GASKET,WATERBOX 150 PSI (FR#3): Note: Used on 2 pass frame #3 condensers, marine W/B end only.
135B	1	-	09XB45001101	GASKET,WATERBOX 150 PSI (FR#3): Note: Used on 2 pass frame #3 condensers, blank end only.
135C	1	-	09XB45002401	GASKET,WATERBOX 300 PSI (FR#3): Note: Used on 2 pass frame #3 condensers, marine W/B end only.
135D	1	-	09XB45002801	GASKET,WATERBOX 300 PSI (FR#3): Note: Used on 2 pass frame #3 condensers, blank end only.
136	1	-	SEENOTESFORUSAGE	FRAME #4 CONDENSOR WATERBOX GASKETS
136A	1	-	09XR45000801	GASKET,WATERBOX 150 PSI (FR#4): Note: Used on 2 pass frame #4 condensers, marine W/B end only.
136B	1	-	09XR05007001	GASKET,WATERBOX 150 PSI (FR#4): Note: Used on 2 pass frame #4 condensers, dished head end only.
136C	2	-	09XR05007001	GASKET,WATERBOX 150 PSI (FR#4): Note: Used on 1 & 2 pass frame #4 condenser, w/dished heads both ends.
136D	1	-	09XR45000801	GASKET,WATERBOX 150 PSI (FR#4): Note: Used on 2 pass fr #4 condenser, w/bolted on head, marine W/B end
136E	1	-	09XR05007001	GASKET,WATERBOX 150 PSI (FR#4): Note: Used on 2 pass fr #4 condenser, w/bolted on head,dished head end
136F	1	-	09XR45001601	GASKET,WATERBOX 150 PSI (FR#4): Note: Used on 2 pass fr #4 condenser, w/bolted on head, w/b to vessel.
136G	1	-	09XB45001001	GASKET,WATERBOX 300 PSI (FR#4): Note: Used on 2 pass frame #4 condensers, marine W/B end only.
136H	1	-	09XB45001001	GASKET,WATERBOX 300 PSI (FR#4): Note: Used on 2 pass frame #4 condensers, blank end only.
137	1	-	SEENOTESFORUSAGE	FRAME #5 CONDENSOR WATERBOX GASKETS
137A	1	-	09XR55000801	GASKET,WATERBOX 150 PSI (FR#5): Note: Used on 2 pass frame #5 condensers, marine W/B end only.
137B	1	-	09XR05007002	GASKET,WATERBOX 150 PSI (FR#5): Note: Used on 2 pass frame #5 condensers, dished head end only.
137C	2	-	09XR05007002	GASKET,WATERBOX 150 PSI (FR#5): Note: Used on 1 & 2 pass frame #5 condenser, w/dished heads both ends.
137D	1	-	09XR55000801	GASKET,WATERBOX 150 PSI (FR#5): Note: Used on 2 pass fr #5 condenser, w/bolted on head, marine W/B end
137E	1	-	09XR05007002	GASKET,WATERBOX 150 PSI (FR#5): Note: Used on 2 pass fr #5 condenser, w/bolted on head,dished head end
137F	1	-	09XR55001601	GASKET,WATERBOX 150 PSI (FR#5): Note: Used on 2 pass fr #5 condenser, w/bolted on head, w/b to vessel.
137G	1	-	09XR55001001	GASKET,WATERBOX 300 PSI (FR#5): Note: Used on 2 pass frame #5 condensers, marine W/B end only.
137H	1	-	09XR55001001	GASKET,WATERBOX 300 PSI (FR#5): Note: Used on 2 pass frame #5 condensers, blank end only.
138	1	-	TUBEQUANTITY	COOLER TUBES (SEE NOTE): NOTE: TO OBTAIN THE PROPER TUBES FOR YOUR PARTICULAR MACHINE CONTACT YOUR CARRIER REPRESENTATIVE. YOU MUST PROVIDE MACHINE SERIAL NO.
138A	1	-	200	COOLER TUBE QTY. (FR# 30,35)
138B	1	-	240	COOLER TUBE QTY. (FR# 31,36)
138C	1	-	282	COOLER TUBE QTY. (FR# 32,37)
138D	1	-	324	COOLER TUBE QTY. (FR# 40,45)
138E	1	-	364	COOLER TUBE QTY. (FR# 41,46)
138F	1	-	400	COOLER TUBE QTY. (FR# 42,47)
138G	1	-	431	COOLER TUBE QTY. (FR# 50,55)
138H	1	-	485	COOLER TUBE QTY. (FR# 51,56)
138I	1	-	519	COOLER TUBE QTY. (FR# 52,57)
139	1	-	TUBEQUANTITY	CONDENSER TUBES (SEE NOTE): NOTE: TO OBTAIN THE PROPER TUBES FOR YOUR PARTICULAR MACHINE CONTACT YOUR CARRIER REPRESENTATIVE. YOU MUST PROVIDE MACHINE SERIAL NO.
139A	1	-	218	CONDENSER TUBE QTY. (FR# 30,35)
139B	1	-	266	CONDENSER TUBE QTY. (FR# 31,36)

Itm#	Qty	Rec	Part Number	Description
139C	1	-	315	CONDENSER TUBE QTY. (FR# 32,37)
139D	1	-	366	CONDENSER TUBE QTY. (FR# 40,45)
139E	1	-	415	CONDENSER TUBE QTY. (FR# 41,46)
139F	1	-	464	CONDENSER TUBE QTY. (FR# 42,47)
139G	1	-	507	CONDENSER TUBE QTY. (FR# 50,55)
139H	1	-	556	CONDENSER TUBE QTY. (FR# 51,56)
139I	1	-	602	CONDENSER TUBE QTY. (FR# 52,57)
140	4	-	19EF5011212	WELL,SENSOR
142	1	-	23XR05000701	DUCT,WIRING
143	1	-	23XR05000901	DUCT,WIRING
144	2	-	23XR05001001	DUCT,WIRING
145	4	R	HH79NZ024	SENSOR,TEMPERATURE (W/20' CABLE)
146	1	R	HK02ZA165	SWITCH,HIGH PRESSURE (DISCHARGE)
147	1	-	DC99RA015	CONNECTOR (COMPRESSION X MALE MPT)
148	5	-	AS84ZZ102	MOUNT,CABLE
149	5	-	HK05YZ007	TRANSDUCER,PRESSURE
150	1	-	23XR04007501	CONTROLLER (ICVC)
150A	1	-	23XR04001201	CONTROL PANEL ASY (BASIC PANEL): Includes: Items 151 - 192.
150B	1	-	23XR04001202	CONTROL PANEL ASY (BASIC W/DATAPORT)
150C	1	-	23XR04001203	CONTROL PANEL ASY (BASIC W/DATALINK): Includes: Items 151 - 192.
151	1	-	23XR05001701	> TRANSFORMER (T1)
152	1	-	23XR05001601	> TRANSFORMER (T2) (DATAPORT/DATALINK)
153	1	-	23XR05001401	> PANEL,WIRING
154	1	-	23XR05001901	> BRACKET,CIRCUIT BRACKET
155	1	-	23XR05001801	> BRACKET,MODULE (DATAPORT/DATALINK)
156	1	-	23XR05002001	> CABLE ASY (CCM TO CVC)
157	1	-	CES0130038	> MODULE,CHILLER CONTROL (CCM)
157A	1	-	CEPL130363-01	> MODULE (DATAPORT)
157B	1	-	CEFA121549-02	> MODULE (DATALINK)
158	4	R	HH83ZB001	> BREAKER,CIRCUIT (3.2 AMP)
159	2	-	23XR05008201	> CONTACTOR (1C & 6C)
160	1	-	HK99ZZ001	> SURPRESSOR,NOISE (SNUBBER)
161	2	-	HN61KK224	> RELAY (2C) & (3C W/HGBP)
162	2	R	HT21AZ111	> RESISTOR (4.3K)
163	1	-	HY84FE003	> BLOCK,TERMINAL
164	1	-	23XR05006201	> ACTUATOR ASY,OIL RECLAIM W/CABLE)
164A	1	-	ZG-R01	> RESISTOR (500 OHM) (USED W/IT 164)
165	1	-	19XB660008	> CABLE ASY (OIL SUMP PRESS.)
166	1	-	19XB660008	> CABLE ASY (ICVC TO COMM TB)
167	1	-	19XB660008	> CABLE ASY (DISCH. OIL PRESS.)
168	1	-	19XB660008	> CABLE ASY (EVAP. PRESS.)
169	1	-	19XB660008	> CABLE ASY (COND. PRESS.)
170	1	-	19XB660008	> CABLE ASY (DISCH.PRESS.)
171	1	-	19XB660008	> CABLE ASY (COMMUNICATION)
172	1	R	HH79NZ031	> SENSOR ASY (EVAP. LVG. LIQ. TEMP.)
173	1	R	HH79NZ031	> SENSOR ASY (EVAP. ENT. LIQ. TEMP.)
174	1	R	HH79NZ031	> SENSOR ASY (COND. LVG. LIQ. TEMP.)
175	1	R	HH79NZ031	> SENSOR ASY (COND. ENT. LIQ. TEMP.)
176	1	R	HH79NZ031	> SENSOR ASY (COMPR. OIL SUMP TEMP.)
177	1	R	HH79NZ031	> SENSOR ASY (EVAP. SAT. TEMP.)
178	1	R	HH79NZ031	> SENSOR ASY (COMPR. DISCH. TEMP.)
179	1	R	HH79NZ031	> SENSOR ASY (VAPORIZER TEMP.)
180	1	R	23XR04007701	> SENSOR ASY (HUMIDITY)
181	1	-	23XR04005901	> CABLE ASY (VFD COOLANT)
182	1	-	23XR04007101	> CABLE ASY (COMPR. MTR. WINDING TEMP.)
183	1	-	HY06AM015	> PLUG,CONNECTOR (2 PIN)
184	1	-	HY06MP106	> PLUG,CONNECTOR (6 PIN)

Itm#	Qty	Rec	Part Number	Description
185	1	-	HY07MP505	> PLUG,CONNECTOR (5 PIN): Note: Used at CVC connection from CCM.
186	1	-	HY84EE103	> PLUG,CONNECTOR (3 PIN)
187	1	-	HY84EE104	> PLUG,CONNECTOR (4 PIN)
188	1	-	HY84EE106	> PLUG,CONNECTOR (6 PIN)
189	1	-	HY84EE112	> PLUG,CONNECTOR (12 PIN)
190	1	-	HY84EE114	> PLUG,CONNECTOR (14 PIN)
191	1	-	HY84EE132	> PLUG,CONNECTOR (12 PIN)
192	1	-	HY84EE134	> PLUG,CONNECTOR (14 PIN)
193	2	-	DF34CA019	CONNECTOR (VFD TO MACHINE CONN.)
194	2	-	KK71EW016	O-RING (VFD TO MACHINE CONN.)
195	2	-	DF01CA007	NUT,BRASS (VFD TO MACHINE CONN.)
196	2	-	DF02CA025	SLEEVE,FITTING (VFD TO MACHINE CONN.)
200A	1	-	179615-903	VFD DRIVE (903)(LIQ-FLO II)(REF. ONLY): Note: Part number listed is generic with no options listed "00".
200B	1	-	179615-943	VFD DRIVE (943)(LIQ-FLO II)(REF. ONLY): Note: Part number listed is generic with no options listed "00".
200C	1	-	179615-904	VFD DRIVE (904)(LIQ-FLO II)(REF. ONLY): Note: Part number listed is generic with no options listed "00".
200D	1	-	179615-905	VFD DRIVE (905)(LIQ-FLO II)(REF ONLY): Note: Part number listed is generic with no options listed "00".
201	1	-	21T-180086	> CONTROL TRANSFORMER (3KVA)
202A	1	-	21T-317826-Q02	> MAIN BREAKER (65K)(CB1) (FR# 903)
202B	1	-	21T-317826-Q01	> MAIN BREAKER (65K)(CB1) (FR# 904)
202C	1	-	21T-317826-Q01	> MAIN BREAKER (65K)(CB1) (FR# 905)
202D	1	-	21T-317826-Q01	> MAIN BREAKER (65K)(CB1) (FR# 943)
202E	1	-	21T-180623-Q01	> MAIN BREAKER (100K)(CB1) (FR# 903)
202F	1	-	21T-180623-Q02	> MAIN BREAKER (100K)(CB1) (FR# 904)
202G	1	-	21T-180623-Q02	> MAIN BREAKER (100K)(CB1) (FR# 905)
202H	1	-	21T-180623-Q02	> MAIN BREAKER (100K)(CB1) (FR# 943)
203A	1	-	21T-162227	> CONTROL CIRCUIT BREAKER (65K)(CB2)
203B	1	-	21T-371353-Q01	> CONTROL CIRCUIT BREAKER (100K)(CB2)
204A	1	-	21T-179607-Q02	> INPUT INDUCTOR (FRAME 903)
204B	1	-	21T-179607-Q03	> INPUT INDUCTOR (FRAME 943)
204C	1	-	21T-179607-Q03	> INPUT INDUCTOR (FRAME 904)
204D	1	-	21T-179607-Q04	> INPUT INDUCTOR (FRAME 905)
205	1	-	21T-320716	> PRE-CHARGER CONTACTOR
206	1	-	21T-422302-1E	> PRE-CHARGED RESISTOR
207A	1	-	21T-362707-A03	> INPUT FILTER CAP. (FRAME 903)
207B	1	-	21T-362707-A02	> INPUT FILTER CAP. (FRAME 943)
207C	1	-	21T-362707-A02	> INPUT FILTER CAP. (FRAME 904)
207D	1	-	21T-362707-A01	> INPUT FILTER CAP. (FRAME 905)
208A	1	-	21T-RX-LF200460AAR	> POWER MODULE (FRAME 903)
208B	1	-	21T-RX-LF200460BAR	> POWER MODULE (FRAME 943)
208C	1	-	21T-RX-LF200520BBR	> POWER MODULE (FRAME 904)
208D	1	-	21T-RX-LF200608BAR	> POWER MODULE (FRAME 905)
209	1	-	21T-180090-A01	> AC LINE I/O BOARD
210	1	-	21T-180063-A01	> RECTIFIER CONTROL ASSEMBLY
211	1	-	21T-180064-A01	> INVERTER CONTROL ASSEMBLY
212A	1	-	21T-351839-A04	> RECTIFIER INTERFACE ASY (FRAME 903)
212B	1	-	21T-351839-A02	> RECTIFIER INTERFACE ASY (FRAME 943)
212C	1	-	21T-351839-A02	> RECTIFIER INTERFACE ASY (FRAME 904)
212D	1	-	21T-351839-A05	> RECTIFIER INTERFACE ASY (FRAME 905)
213A	1	-	21T-351893-A04	> INVERTER INTERFACE ASY (FRAME 903)
213B	1	-	21T-351893-A04	> INVERTER INTERFACE ASY (FRAME 943)
213C	1	-	21T-351893-A02	> INVERTER INTERFACE ASY (FRAME 904)
213D	1	-	21T-351893-A05	> INVERTER INTERFACE ASY (FRAME 905)
214A	1	-	21T-351893-A10	> RECTIFIER POWER INTERFACE HARNESS
214B	1	-	21T-351893-A10	> INVERTER POWER INTERFACE HARNESS
215	1	-	21T-180062-A01	> COMMUNICATON INTERFACE ASSEMBLY

Itm#	Qty	Rec	Part Number	Description
216	1	-	21T-191673-Q02	> INTERNAL FAN
217	1	-	21T-179196	> FAN
218	1	-	21T-180089-A01	> 80W POWER SUPPLY ASSEMBLY
219	1	-	21T-180060-A01	> STANDARD I/O ASSEMBLY
220	1	-	21T-392134-A01	> RECOMM-CARRIER (GATEWAY)
221	1	-	21T-180043	> LINE SYNC PC BOARD ASSEMBLY
225	1	-	21T-180037-A01	> EXTERNAL NTC ASSEMBLY
226	1	-	21T-69739-48A	> INTERNAL FAN
230	1	-	23XR04000306	METER PACKAGE OPTION (REFERENCE ONLY)
231	1	-	180621-Q01	> AMMETER
232	1	-	180620-Q01	> VOLTMETER
233	1	-	800MR-JH2BLA	> METER SWITCH (PHASE SELECTOR)
244	1	-	8TR0070	ROLLER BEARING,CYL. (MALE INLET)
245	1	-	8TR0068	ROLLER BEARING,CYL. (FEMALE INLET)
246	1	-	8TR0110	O-RING (LAB'Y SEAL)
247	2	-	8TR0254	O-RING (FLOATING BUSHING)
248	1	-	1TR0360	LAB'Y SEAL (MALE ROTOR SIDE-INLET)
249	24	-	8TR0363	SCREW,HEX HEAD CAP (7/8-9UNC X 2LG)
250	6	-	8TR0116	SCREW,SOCKET HEAD CAP (M5 X 0.8 X 30)
251	3	-	8TR0117	SCREW,SOCKET HEAD CAP (M5 X 0.8 X 60)
252	1	-	0TR0218	ROTOR SET (8-6-6)
253	2	-	1TR0348	SEAL,INLET
254	2	-	8TR0304	SCREW,SOCKET HEAD CAP (M20 X 2.5 X 120)
255	2	-	1TR0361	FLOATING BUSHING (FEMALE OUTLET)
256	3	-	8TR0252	SPRING PIN (3 X 10)
257	2	-	8TQ0147	ROLLER BEARING,CYL. (FEMALE OUTLET)
258	1	-	1TR0362	FLOATING BUSHING (MALE OUTLET)
259	1	-	8TR0359	O-RING,FLOATING BUSHING (MALE OUTLET)
260	7	-	8TR0115	SCREW,SOCKET HEAD CAP (M5 X 0.8 X 16)
261	2	-	8TR0228	SPACER,FEMALE INSIDE BEARING (OUTLET)
262	1	-	CT99QN851	RING GASKET,SUCTION COVER (SHIPPING)
263	1	-	CT99QN951	RING GASKET,DISCHARGE COVER (SHIPPING)
264	1	-	SHIMKIT/DWG0TR0222	FEMALE SHIM KIT
265	4	-	8TQ0145	BALL BEARING,ANGULAR CONTACT (FEMALE)
266	2	-	1TR0249	ROTOR CAP,FEMALE (OUTLET)
267	15	-	8TQ0189	SCREW,SOCKET HEAD CAP (M6 X 1.0 X 25)
268	2	-	1TR0235	THRUST WASHER,FEMALE (OUTLET)
269	2	-	KK71EW471	O-RING (ROTOR CASE/OUTLET CASE SEAL)
270	2	-	1TR0088	DOWEL,ROUND (19.05 DIA X 19.05 LG)
271	1	-	1TR0234	SPACER,MALE INSIDE BEARING (OUTLET)
272	1	-	SHIMKIT/DWG0TR0222	MALE SHIM KIT
273	1	-	1TR0245	AXIAL SEAL,MALE
274	3	-	8TR0202	BALL BEARING,ANGULAR CONTACT (MALE)
275	1	-	1TR0248	ROTOR CAP,MALE (OUTLET)
276	1	-	1TR0236	THRUST WASHER,MALE (OUTLET)
277	1	-	8TR0246	SPRING,MALE (OUTLET COUNTERTHRUST)
278	2	-	8TR0247	SPRING,FEMALE (OUTLET COUNTERTHRUST)
279	1	-	1TR0243	GASKET,BEARING COVER PLATE
280	1	-	1TR0242	COVER PLATE,BEARING
281	21	-	8TR0303	SCREW,SOCKET HEAD CAP (M10 X 1.5 X 40)
282	1	-	8TC0290C	FITTING,1/4"NPT(BEARING COVER LUBE PLUG)
283	3	-	8TC0109C	PIPE PLUG,HEX SOCKET (3/4"): Note: for O-ring see item #284.
284	3	-	KK71EW912	O-RING (3/4")
285	14	-	8TR0014	WASHER,FLAT (M20) (HARDENED)
286	14	-	1TR0045	SCREW,HEX HEAD CAP (M20X260)(THRU BOLT)
287	1	-	1TR0017	LAB'Y SEAL (MALE MOTOR SIDE-INLET)
288	1	-	1TR0191	SLEEVE,MOTOR ROTOR (INLET)
289	1	-	1TR0193	KEY,ROTOR (SQUARE)

Itm#	Qty	Rec	Part Number	Description
290	1	-	5TRNRQ31	MOTOR ASSEMBLY (MODEL 5TR0030)
291	1	-	1TR0192	KEY,STATOR (ROUND)
292	1	-	8TC0089C	SET SCREW,SOCKET HEAD (M10 X 1.5 X 30)
293	1	-	1TR0048	LOCKWASHER, MOTOR ROTOR
294	1	-	8TR0121	SCREW,HEX HEAD CAP (M16 X 70 LG)
295	1	-	1TR0024	ROTOR CAP,MOTOR (MOTOR END)
296	1	-	1TR0028	COVER PLATE,MOTOR TERMINAL
297	1	-	1TR0190	GASKET,MOTOR TERMINAL
298	3	-	HY85AA062	MOTOR TERMINAL (POWER)
299	3	-	AU51AS543	SPRING WASHER (1-1/4 OD)
300	17	-	8TR0120	SCREW,SOCKET HEAD CAP (M12 X 1.75 X 50)
301	1	-	8TD0080C	O-RING (COMPR/MOTOR CASE)
302	1	-	KK71EW128	O-RING (HERMETIC TERMINAL)
303	1	-	HY85FP022	HERMETIC TERMINAL (MOTOR SENSOR)
304	1	-	06EA502453	VALVE PAD
305	1	-	7TC0189C	GASKET,VALVE PAD
306	14	-	8TR0122	SCREW,SOCKET HEAD CAP. (M20 X 2.5 X 80)
307	8	-	8TC01044	SCREW,SOCKET HEAD CAP. (M12 X 1.75 X 30)
308	1	-	8TR0358	FITTING,CHOKE ORIFICE
309	1	-	KK71EX906	O-RING (3/8)
310	2	-	DK29GA005LA	GASKET,LUBE COVER PLATE
311	2	-	1TR0046	LUBE CAP
312	2	-	8TC1036	CHARGING VALVE
313	1	-	8TR0358	PIPE ADAPTER,FEMALE (3/8 TO 1/4): Note: for O-ring see item #314.
314	1	-	KK71EX906	O-RING (3/8")
315	3	-	8TC0107C	PIPE PLUG,HEX SOCKET (3/8"): Note: for O-ring see item #316.
316	4	-	KK71EX906	O-RING (3/8")
317	3	-	8TR0128	PIPE PLUG,HEX SOCKET (7/8"): Note: for O-ring see item #318.
318	3	-	8TR0113	O-RING (7/8")
319	2	-	AL81AB123	DRIVE SCREW #6 (.14 X .25)
320	1	-	CT70EA451	COVER,ECONOMIZER
321	1	-	8TR0258	GASKET,ECONOMIZER COVER
322	1	-	1TR0349	BLOCK,LUBE
323	1	-	1TR0350	GASKET,LUBE BLOCK
324	6	-	8TR0357	ORIFICE,LUBRICATION
325	4	-	8TR0238	SCREW,HEX HEAD CAP (5/8 X 11UNC X 1.88)
326	1	-	8TR0256	O-RING (AXIAL SEAL-INNER)
327	1	-	8TR0257	O-RING (AXIAL SEAL-OUTER)
328A	1	-	19XR04026501	PUMPOUT ASSEMBLY (208/230-3-50/60): Includes: Items 329 - 350.
328B	1	-	19XR04026502	PUMPOUT ASSEMBLY (460-3-60): Includes: Items 329 - 350.
328C	1	-	19XR04026503	PUMPOUT ASSEMBLY (400-3-50): Includes: Items 329 - 350.
329	2	-	DE08DA202	> COUPLING (1/2 MFL X 1/2 ODS)
330	4	-	EP10BA211	> VALVE,DIAPHRAGM (5/8 ODS)
331	2	-	DD02CA051	> NUT,FLARE (1/4)
332	1	-	DE06DA204	> ADAPTOR (5/8 ODF X 3/8 INT FPT)
333	1	-	EB51LZ188	> VALVE,RELIEF (3/8)
334	1	-	EC31EZ212	> VALVE,CHECK (5/8)
335A	1	-	19XR04028201	> CONTROL PANEL (208/230-3-50/60): Includes: Items 336 - 346.
335B	1	-	19XR04028202	> CONTROL PANEL (460-3-60): Includes: Items 336 - 346.
335C	1	-	19XR04028203	> CONTROL PANEL (400-3-50): Includes: Items 336 - 346.
336	1	-	19XR05029201	> > SWITCH,HIGH PRESSURE (S.C.O.U.)
337	1	-	19XR05018801	> > SWITCH,VACUUM
338	1	-	HN53CD115	> > CONTACTOR

Itm#	Qty	Rec	Part Number	Description
339A	2	-	KLDR1/2	> > FUSE,PRIMARY (230V)(FU1 & FU2)
339B	2	-	KLDR1/4	> > FUSE,PRIMARY (460V)(FU1 & FU2)
339C	2	-	KLDR4/10	> > FUSE,PRIMARY (400V)(FU1 & FU2)
340	1	-	KLDR1/2	> > FUSE (FU3)
341	6	-	115188.11	> > BLOCK,TERMINAL (TB)
342	1	-	M3SS4-10B	> > SWITCH,SELECTOR (ON/OFF)(SS1)
343	1	-	MCBH-00	> > HOLDER,SWITCH
344	2	-	CBK-CB10	> > BLOCK,CONTACT (SS1)
345	3	-	030722014	> > HOLDER,FUSE (FU1,FU2,FU3)
346A	1	-	1497-A-BASK-O-N	> > TRANSFORMER (230/460V)(XFMR)
346B	1	-	1497-A-M4-O-N	> > TRANSFORMER (380/400/415)(XFMR)
347	1	-	19XR05016701	> SEPARATOR,OIL
348	1	-	19XR05020901	> CONDENSER
349A	1	-	CS27K6E-TF5-970	> COMPRESSOR (200/230V): Includes: Item 350.
349B	1	-	CS27K6E-TFD-970	> COMPRESSOR (380/420/460): Includes: Item 350.
350	1	-	P041-4131	> > CRANKCASE HEATER
351	2	-	P806-NS4-8	NUT,FLARE (1/2)(PUMPOUT TO CLR&COND)
352	2	-	DD07DA201	COUPLING (1/2)(PUMPOUT TO CLR&COND)
353	1	-	PH23GH022	PAINT (SPRAY CAN)(GRAY)
354	1	-	PH23GH022G	PAINT (GALLON CAN)(GRAY)
355	1	-	GTC-21111/16	BRUSH,TUBE CLEANING (3/4" I.D.)
356	1	-	PP23BZ110001	COMPRESSOR OIL (1 GALLON)
357	1	-	PP23BZ110005	COMPRESSOR OIL (5 GALLON)
358	1	-	PP23BZ110055	COMPRESSOR OIL (55 GALLON)
359	1	-	QR0948486434	INSULATION, SHEET (3/4 X 48 X 64)
360	2	-	19XB05010301	UNIT LOGO "CARRIER"
361	1	R	HK06ZC033	FLOW SWITCH,DIFFERENTIAL PRESSURE
362	1	-	T148521	TOOL (MALE OUTLET ROTOR CAP): Note: Put on rotor during outlet case installation.
363	1	-	T148522	TOOL (FEMALE OUTLET ROTOR CAP): Note: Put on rotor during outlet case installation.
364	1	-	T148523	TOOL (MALE INLET ROTOR CAP): Note: Put on bottom of male rotor where motor rotor goes and use when male rotor is lowered into rotor housing to protect bearings.
365	1	-	T148524	TOOL (FEMALE ROTOR END,OUTLET END)
366	1	-	T148525	TOOL (ROTOR KEY PULLER)
367	1	-	T148526	TOOL (DISASSEMBLY TOOL KIT): Note: Includes, safety blocks, guide pins, drive pads & disasy. plate
368	1	-	T148527	TOOL (MOTOR ROTOR GUIDE): Note: Includes, plate, key & socket head cap screws.
369	1	-	T148528	TOOL (BEARING STORAGE CONTAINER)
370	1	-	T148509	TOOL (STATOR LIFT ASSIST)
371	1	-	T148511	TOOL (M5 GUIDE PIN): Note: Used for seals and other internals.
372	1	-	T148512	TOOL (M6 GUIDE PIN): Note: Used for assembling male axial seal and floating bushing at the discharge end of compressor.
373	1	-	T148513	TOOL (M20 GUIDE PIN): Note: Used to assemble outlet casing to rotor casing and discharge case to outlet case.
374	1	-	T148514	TOOL (BRG. DRIVER ASY,MALE OUTLET)
375	1	-	T148515	TOOL (LOCATING PLG,MALE OUTLET SEAL)
376	1	-	T148516	TOOL (TAMPING ROD): Note: used to tamp seals in place.
377	1	-	T148517	TOOL (END TURN PROTECTOR)
378	1	-	T148518	TOOL (TERMINAL PIN SOCKET): Note: Used to assemble terminal pins to compressor.
379	1	-	T148520	TOOL (RAD. BRG HOLD DOWN, FEMALE DISCH)
381	1	-	56507	LOCTITE (6 ML TUBE)
382	1	-	56531	LOCTITE (50 ML TUBE)
383	1	-	56541	LOCTITE (250 ML TUBE)
384	1	-	56571	LOCTITE (300 ML CARTRIDGE)



Itn#	Qty	Rec	Part Number	Description
385	1	-	PP8024	HEAT SHRINK COMPOUND (5 OZ TUBE)
386	1	-	19XL680001	O-RING LUBRICANT
387	1	-	19XL680002	GASKET SEALANT