

Installation, Operation and Start-Up Instructions

CONTENTS

	Page
INSTALLATION	1-8
General	1
Entering Air Thermistor	1
Leaving Air Thermistor	1
Local Interface Device Auxiliary Box	1
Local Interface Device Remote Mounting	2
Field Electrical Connections	2
Two-Step Demand Limit	2
CONTROL SYSTEM	8
General	8
Features	8
CONTROL OPERATION	8-18
Accessing Functions and Subfunctions	8
Display Functions	12
• SUMMARY DISPLAY	12
• STATUS FUNCTION	12
• HISTORY FUNCTION	14
• TEST FUNCTION	14
Programming Functions	15
• SERVICE FUNCTION	15
• SET POINT FUNCTION	16
• SCHEDULE FUNCTION	16
CONTROL OPERATING SEQUENCE	19
START-UP	19-20
Initial Check	19
Quick Test	20
TROUBLESHOOTING	21-32
Self Health Check	21
Control Diagnostic Information	21

SAFETY CONSIDERATIONS

Installation and start-up of air conditioning equipment can be hazardous due to system pressures, electrical components and equipment locations. Only trained and qualified service personnel should install, start up or service air conditioning equipment.

When working on air conditioning equipment, observe precautions in the literature, tags, stickers and labels attached to the equipment and any other safety precautions that may apply.

- Follow all safety codes.
- Wear safety glasses and work gloves.
- Use care in handling, rigging and placing bulky equipment.
- Use care in handling electronic components.

▲ WARNING

Disconnect all power to the unit before performing maintenance or service. Unit may automatically start if power is not disconnected. Electrical shock and personal injury could result.

▲ WARNING

This unit uses a microprocessor-based electronic control system. Do not use jumpers or other tools to short out components, bypass or otherwise depart from recommended procedures. Any short-to-ground of the control board or accompanying wiring may destroy the electronic modules or electrical component.

INSTALLATION

General — Follow all normal installation instructions as described in the 50BJ, BK Installation, Start-Up and Service Instructions shipped with the unit.

Entering Air Thermistor (EAT.) — The EAT. is factory supplied for field installation upstream of the evaporator coil, preferably ahead of the filters. It is pre-wired to the controls on 028 - 064 units.

On 024 units, the EAT. is shipped coiled and taped to the bottom of the local interface device auxiliary box. See Local Interface Device Auxiliary Box section for installation and wiring details.

On 028 and 034 units, the EAT. is shipped coiled and taped in the bottom of the local interface device auxiliary box mounted in the end of the unit. For shipment on 044 - 064 units, the EAT. is coiled and placed in the 24-volt wiring enclosure in the upper right hand corner of the control box.

Leaving Air Thermistor (LAT) — On 024 units, the LAT is factory supplied for field installation downstream of the evaporator coil. See Local Interface Device Auxiliary Box section for installation and wiring details.

On 028 - 064 units, the LAT is factory installed and wired.

Local Interface Device Auxiliary Box (024 units only) (Fig. 1) — The local interface device auxiliary box on size 024 units is shipped behind the filters. It must be removed and relocated for operation.

Remove auxiliary box from shipped location. Remove panel from middle section of control box end of unit. Discard panel, but save the 4 screws. Using the 4 screws, mount the auxiliary box over the opening exposed by the panel removal. See Fig. 2.

Remove cloth bag from inside of auxiliary box. This contains connectors, varnish cloth, wire ties, etc. that will be needed later.

Attach leaving air thermistor cable (labelled '1') to terminals 2 and 3 on terminal block J7 on the processor module (PSIO). Attach entering air thermistor cable (labelled '2') to terminals 5 and 6 on terminal block J7 on the processor module. Route both sensors and wires through the connector at the back of the auxiliary box. Refer to Fig. 2 and unit wiring diagram for wiring details.

Install 1/2-in. connector and varnish cloth on LAT bracket mounted on top of evaporator coil. Route LAT sensor into connector. See View A-A, Fig. 2.

Route EAT sensor to the front of the evaporator coil through the partition at the end of the coil. Fasten the sensor to the liquid line bracket with wire ties provided.

Two plug assemblies (PL5 and PL7) are fastened to the liquid lines with tape. Remove the tape and connect the assemblies to PL4 and PL6 located on the back of the auxiliary box. Coil any excess wire and retape to the liquid line.

Run communication cable from inside of auxiliary box into main control box. Cable should run through connector in back of auxiliary box, through partition at end of evaporator coil, through connector in condensate deck and finally into the main control box through a hole in the right hand side of control box. Attach 4-pin connector (found in cloth bag) to communication cable. Fasten communication cable to relay module (DSIO) COMM connection. Connect RED wire to Pin 1, WHITE wire to Pin 2, and BLACK wire to PIN 3.

NOTE: Be sure communication cable is installed inside main control box BEFORE attaching 4-pin connector. Four-pin connector does not fit through hole in main control box panel.

Seal connector on auxiliary box with RTV sealant. Replace unit access panel.

Local Interface Device Remote Mounting — The local interface device may be removed and mounted in another location. Remove the power and communication plugs at the top of the module, remove the 4 mounting screws, and relocate the module to the desired indoor location. The inter-connecting wiring will consist of 5 field-supplied wires, to be no longer than 1000 feet each. The two 21-volt power wires must be at least 20 gage, and the 3 communication wires must be 20 gage Belden 8772 shielded cable or equivalent. The 2 plugs have screw terminals, for ease in removing and replacing the wires.

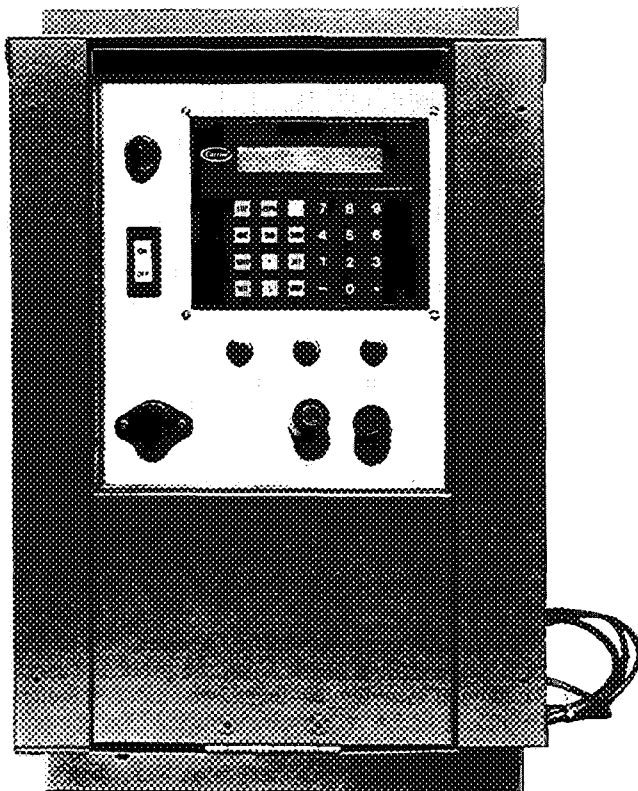

Fig. 1 — Local Interface Device Auxiliary Box (024 Units Only)

Field Electrical Connections

IMPORTANT: This equipment generates, uses and can radiate radio frequency energy. If units are not installed and used in accordance with these instructions, they may cause radio interference. They have been tested and found to comply with limits of a Class A computing device as defined by FCC regulations, Subpart J of Part 15, which are designed to provide reasonable protection against such interference when operated in a commercial environment.

CONTROL WIRING (Fig. 3 and 4) — All control modules are powered by factory-installed 21-vac transformers. Refer to Fig. 5 - 7 for control box component arrangements. Refer to the wiring diagrams at the end of this book for further details.

Outdoor Fan Relay — A separate outdoor fan relay is no longer supplied on 50BK units. This function is now handled by the control relay module. The relay module closes a set of contacts between Terminals 1 and 2 on TB5 (024 - 034 units) or TB6 (044 - 064 units). The outdoor fan contactors can be activated directly from these terminals providing the load is not greater than 2 amps at 115 volts. The circuit can be powered internally from the 115-volt circuit, or from an external 24-volt or 115-volt circuit. See Fig. 3 and 4.

Unoccupied Cooling//Temperature Reset — The Unoccupied Cooling and temperature reset functions utilize the same thermistor. Install a field-supplied thermistor (P/N HH79NZ018 or HH51BX001) in the conditioned space, usually at a location where it will not trigger reset until the majority of the building is satisfactorily cool.

Connect thermistor wires to terminals 4 and 5 of TB4 (024 - 034 units) in the local interface device auxiliary box, or TB5 (044 - 064 units) in the unit panel.

If space temperature sensor HH51BX001 is used, the thermistor cable connects to terminals 1 and 2 on TB1 inside sensor cover. The jumper in the sensor cover is used to configure the sensor. It must be located between Pin E2 and Pin E3. See Fig. 8 for correct connections.

NOTE: On 50BJ, BK units, the network timed override button does not function on the HH51BX001 sensor.

External Time Clock — To control the unit Occupied/Unoccupied modes from an external time clock, the clock must switch a 24-volt signal from terminal 11 of TB3 to terminal 1 of TB3 (024 - 034 units) or from terminal 20 of TB5 to terminal 21 of TB5 (044 - 064 units). When 24 volts is provided at terminal 1 or 21, the unit enters the Occupied mode. When the 24-volt signal is removed, the unit enters the Unoccupied mode.

NOTE: The PIC unit has an internal clock with capability of scheduling up to 8 Occupied or Unoccupied periods. If the external time clock is used, the internal clock should be disabled.

Two-Step Demand Limit — Field-supplied external switching (demand limiter) is required to activate the Demand Limit option. One switch will close a circuit between Terminals 8 and 11 of TB3 (024 - 034 units) or Terminals 8 and 12 of TB5 (044 - 064 units) to activate the first step. Another switch will close a 24-volt circuit between Terminals 9 and 11 of TB3 (024 - 034 units) or Terminals 9 and 12 of TB5 (044 - 064 units) to activate the second step. If both circuits are closed at the same time, the second stage takes priority.

When the unit is connected to the Carrier Comfort Network, unit Demand Limit can be activated using the network Loadshed option. The redline alert acts as the first

step of unit demand. The second level of demand is activated by the network Demand Limit command. The unit Demand Limit set points remain the same.

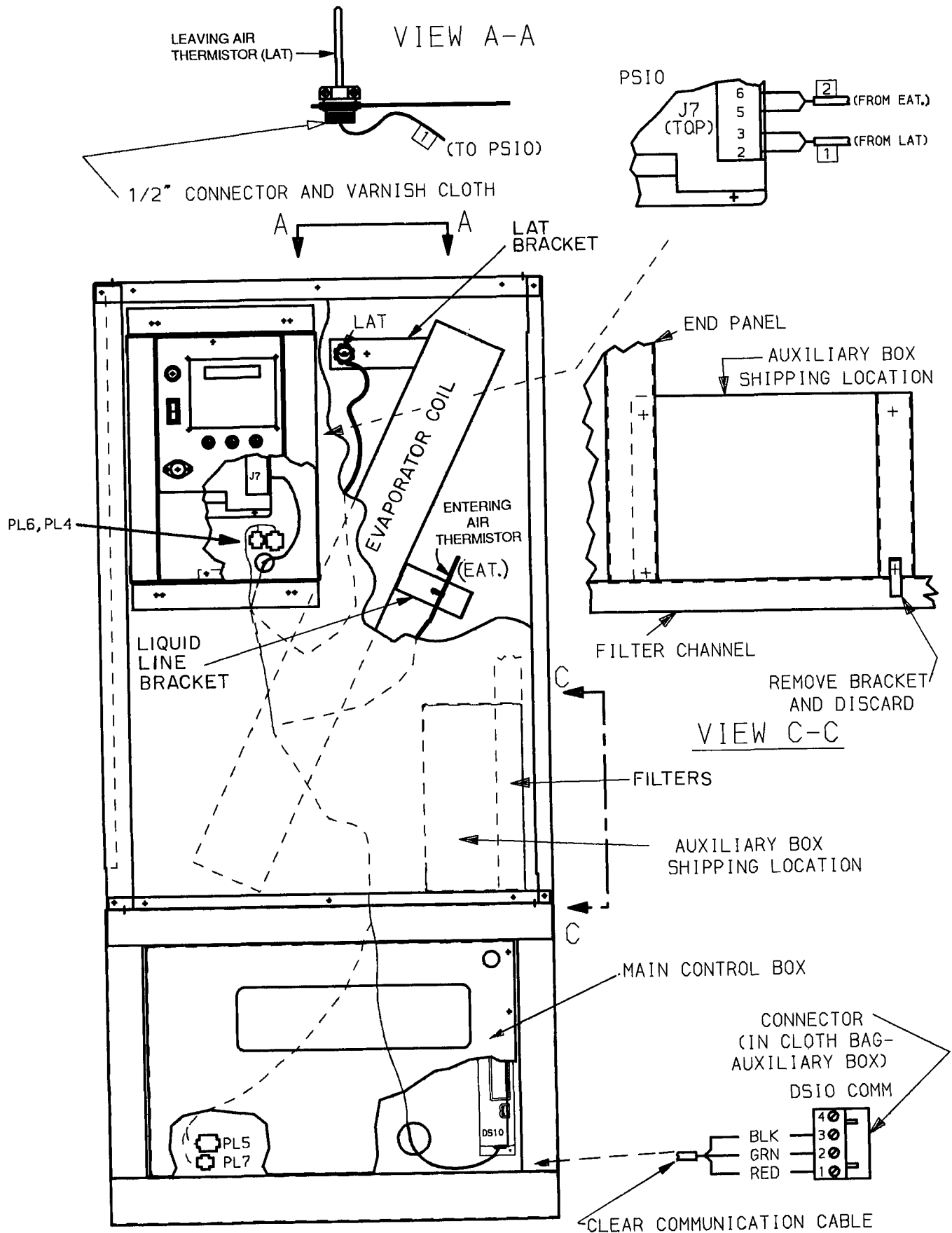
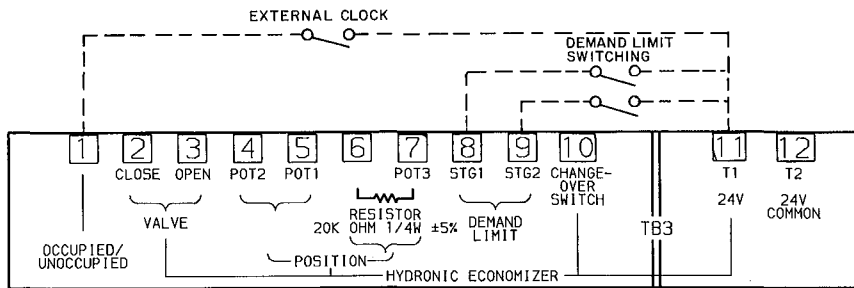
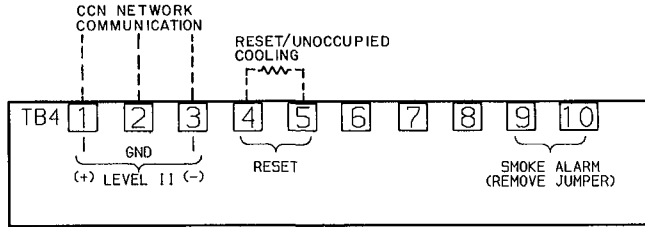
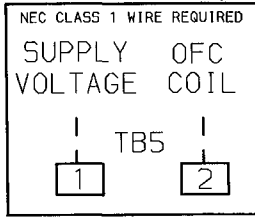

Fig. 2 - Local Interface Device Auxiliary Box Mounting and Sensor Routing (024 Units)

50BK UNITS (120 v max)

50BK UNITS (120 V MAX)



LEGEND

- GND - Ground
- OFC - Outdoor Fan Contactor
- POT. - Potentiometer
- STG - Stage
- T - Terminal
- TB - Terminal Block

Fig. 3 - Field Control Wiring, Models 50BJ, BK024-034

50BK UNITS (120 v max)

50BK UNITS (120 V MAX)

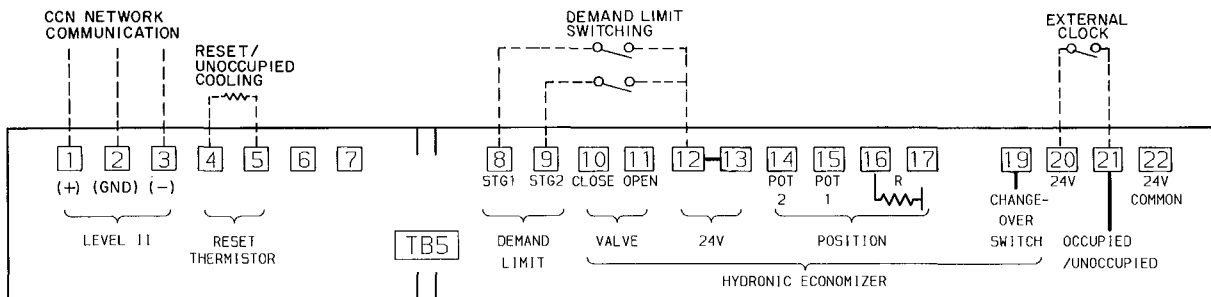
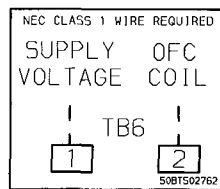

LEGEND

- GND - Ground
- OFC - Outdoor Fan Contactor
- POT. - Potentiometer
- R - Resistor
- STG - Stage
- TB - Terminal Block

Fig. 4 - Field Control Wiring, Models 50BJ, BK044-064

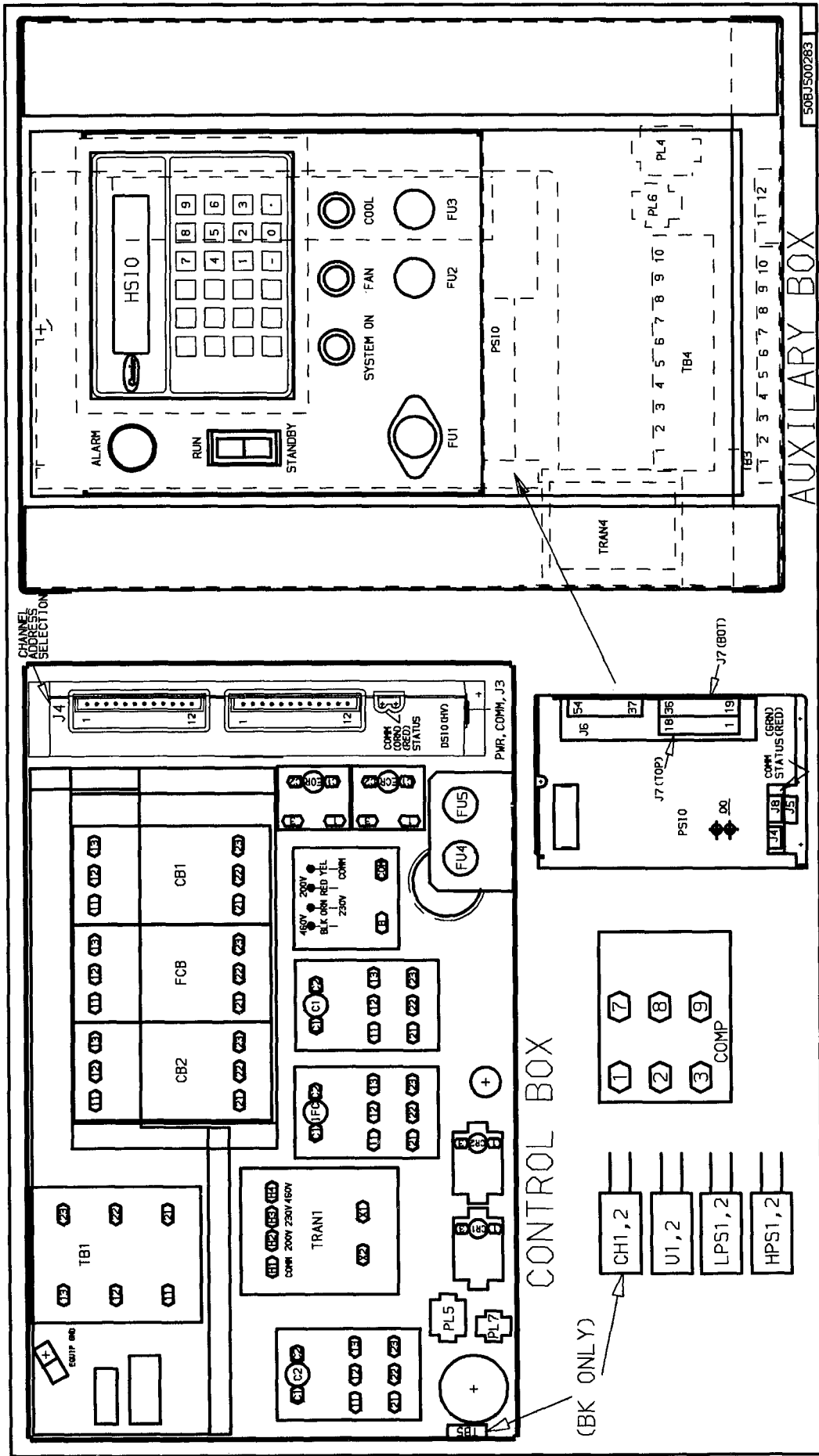

Fig. 5 - Control Box Component Arrangement; 50BJ, BK024

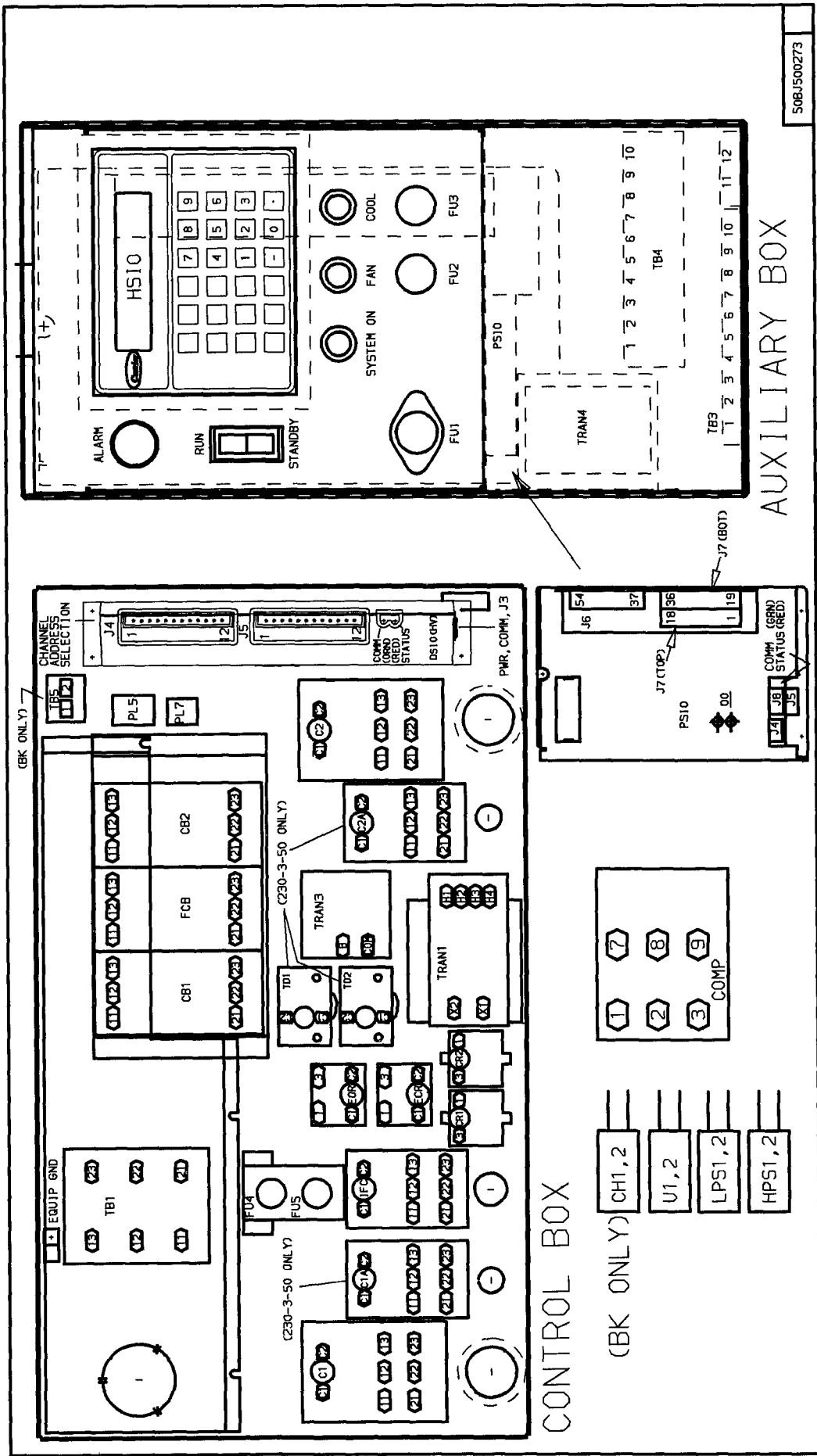

Fig. 6 — Control Box Component Arrangement; 50BJ, BK028 and 034

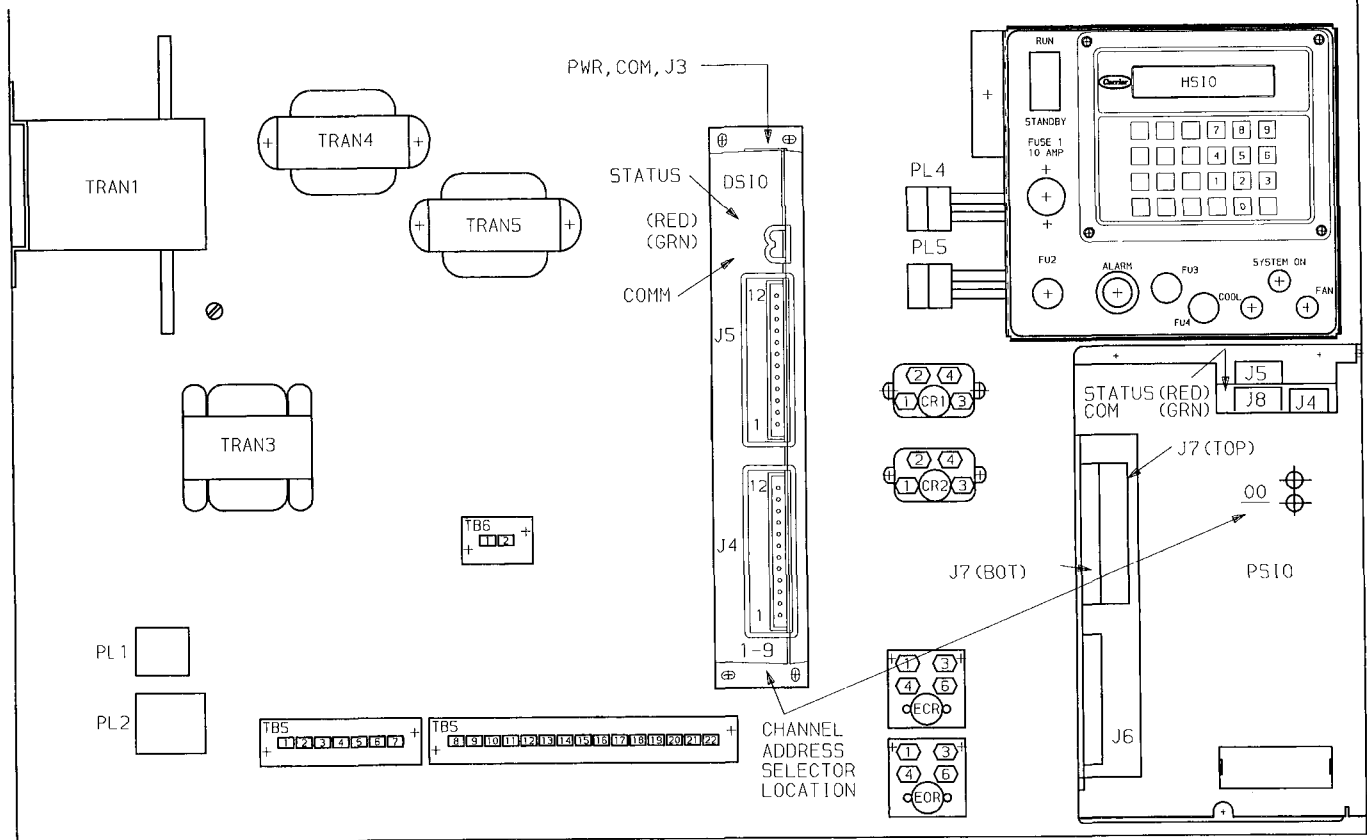

Fig. 7 - Control Box Component Arrangement; 50BJ, BK044-064

LEGEND FOR FIG. 5 - 7

- C** - Contactor
- CB** - Circuit Breaker
- CH** - Crankcase Heater
- COMP** - Compressor
- COMM** - Communication
- CR** - Compressor Relay
- DSIO** - Relay Module
- ECR** - Economizer Close Relay
- EOR** - Economizer Open Relay
- EQUIP** - Equipment
- FCB** - Fan Circuit Breaker
- FU** - Fuse
- GND** - Ground
- HPS** - High-Pressure Switch
- HSIO** - Local Interface Device
- IFC** - Indoor Fan Contactor
- LPS** - Low-Pressure Switch
- PL** - Plug
- PSIO** - Processor Module
- TB** - Terminal Block
- TRAN** - Transformer
- U** - Unloader

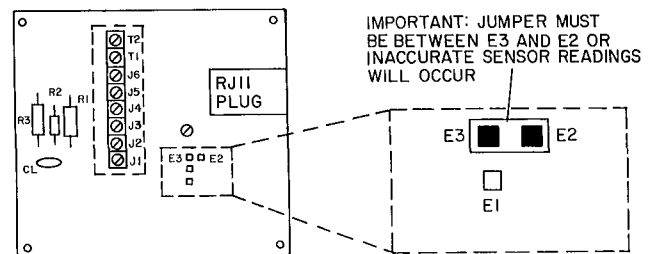

Fig. 8 - Space Temperature Sensor Wiring (HH51BX001)

CARRIER COMFORT NETWORK INTERFACE — The Carrier Comfort Network (CCN) communication bus wiring is supplied and installed by the electrical contractor. It consists of shielded, 3 conductor cable with drain wire.

The system elements are connected to the communication bus in a daisy chain arrangement. The positive pin of each system element communication connector must be wired to the positive pins of the system element on either side of it; the negative pins must be wired to the negative pins; the signal ground pins must be wired to signal ground pins.

NOTE: Conductors and drain wire must be 20 AWG minimum stranded, tinned copper. Individual conductors must be insulated with PVC, PVC/nylon, vinyl, Teflon®, or polyethylene. An aluminum/polyester 100% foil shield and an outer jacket of PVC, PVC/nylon, chrome vinyl or Teflon® with a minimum operating temperature range of -20 C to 60 C is required. See table below for cables that meet the requirements.

MANUFACTURER	CABLE NO.
Alpha	2413 or 5463
American	A22503
Belden	8772
Columbia	02525

When connecting the CCN communication bus to a system element, a color code system for the entire network is recommended to simplify installation and checkout. The following color code is recommended:

SIGNAL TYPE	CCN BUS CONDUCTOR INSULATION COLOR	TERMINAL NUMBER*
+	RED	1
Ground	WHITE	2
-	BLACK	3

*On TB4 (024 - 034 units) or TB5 (044 - 064 units)

If a cable with a different color scheme is selected, a similar color code should be adopted for the entire network.

At each system element, the shields of its communication bus cables must be tied together. If the communication bus is entirely within one building, the resulting continuous shield must be connected to ground at only one single point. If the communication bus cable exits from one building and enters another, the shields must be connected to ground at the lightning suppressor in each building where the cable enters or exits the building (one point only).

To connect the unit to the network, proceed as follows:

1. Turn power to the PIC control box to OFF.
2. Cut the CCN wire and strip the ends of the RED, WHITE, and BLACK conductors.
3. Using a wire nut, connect the 2 drain wires together.
4. Connect the 2 RED wires to Terminal 1 of TB4 (024 - 034 units) or TB5 (044 - 064 units).
5. Connect the 2 WHITE wires to Terminal 2 of TB4 (024 - 034 units) or TB5 (044 - 064 units).
6. Connect the 2 BLACK wires to Terminal 3 of TB4 (024 - 034 units) or TB5 (044 - 064 units).

CONTROL SYSTEM

General — The control system consists of a processor module (PSIO), a high-voltage relay module (DSIO-HV), and a local interface device (HSIO).

Features

PROCESSOR MODULE — This module contains the operating software and controls the operation of the unit. It continuously monitors information received from various thermistors.

HIGH-VOLTAGE RELAY MODULE — This module closes contacts to energize compressors, unloaders and indoor and outdoor fans.

LOCAL INTERFACE DEVICE (Fig. 9) — This device consists of a keyboard with 6 function keys, 5 operative keys, 10 numeric keys (0 to 9) and an alphanumeric 8 character Liquid Crystal Display (LCD). Key usage is explained in Table 1. Each function has one or more subfunction as shown in Table 2. Those functions are described in greater detail in the Control Operation section of this book.

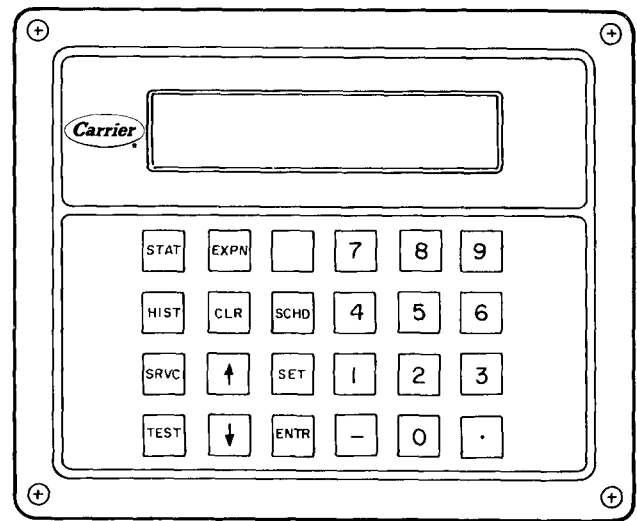

Fig. 9 — Local Interface Device

CONTROL OPERATION

Accessing Functions and Subfunctions — See Table 3. Refer also to Table 2, which shows the 6 functions (identified by name) and the subfunctions (identified by number). Table 4 shows the sequence of all of the elements in a subfunction.

Table 1 – Local Interface Device Key Usage

FUNCTION KEYS	USE	OPERATIVE KEYS	USE
	Status — Displaying diagnostic codes and current operating information about the unit		Expand Display — Displaying a non-abbreviated expansion of the display
	Quick Test — Checking inputs and outputs for proper operation		Clear — Clearing the screen of all displays
	History — Checking most recent alarms		Up Arrow — Returning to previous display position
	Service — Entering specific unit configuration information		Down Arrow — Advancing to next display position
	Set Point — Entering operating set points and day/time information		Entering data
	Schedule — Entering Occupied/Unoccupied schedules for unit operation		

Table 2 – Functions and Subfunctions

SUBFUNCTION NUMBER	FUNCTIONS					
	Status	History	Test	Service	Set Point	Schedule
1	Alarm Displays	Alarm History	Quick Test of Inputs	Log On and Log Off	System	Occupied Mode Override
2	Operating Mode Displays	—	Quick Test of Outputs	Software Version	Reset	Period 1
3	Capacity Stages	—	Quick Test of Compressors	Factory Configurations	Demand Limit	Period 2
4	Current Operating Set Points	—	Terminate Quick Test	Field Configurations	Time	Period 3
5	System Temperatures	—	—	Service Configurations	Unoccupied Cooling	Period 4
6	System Pressures	—	—	Service Variables	—	Period 5
7	System Position	—	—	Network Address	—	Period 6
8	Override	—	—	—	—	Period 7
9	—	—	—	—	—	Period 8

Table 3 – Accessing Functions and Subfunctions

OPERATION	KEYBOARD ENTRY	DISPLAY	DESCRIPTION
To access a function, press the subfunction number and the function name key. The display will show the subfunction group		RESET	Reset Set Points
To move to the other elements, scroll up or down using the arrow keys.		RTS X	Reset Temperature Set Point
		RLS X	Reset Limit
When the last element in a subfunction has been displayed, the subfunction group name will be repeated.		RESET	Reset Set Points
To move to the next subfunction, it is not necessary to use the subfunction number; pressing the function name key will advance the display through all subfunctions within a function and then back to the first.		DEMAND	Demand Limit Set Points
		TIME	Time of Day and Day of Week Display
		SETPOINT	System Set Points
To move to another function, either depress the function name key for the desired function (display will show the first subfunction)		X ALARMS	X Alarms Detected
or			
Access a particular subfunction by using the subfunction number and the function name key.		STAGES	Capacity Stages

Table 4 -- Keyboard Directory

STATUS		
KEYBOARD ENTRY	DISPLAY	COMMENTS
1 STAT	ALARMS	Current alarm displays
↓	ALARM X	Alarm 1
↓	ALARM X	Alarm 2
↓	ALARM X	Alarm 3
↓	ALARM X	Alarm 4
↓	ALARM X	Alarm 5
↓	ALARM X	Alarm 6
↓	ALARM X	Alarm 7
↓	ALARM X	Alarm 8
2 STAT	MODES	Current operating modes
↓	MODE X	Mode 1
↓	MODE X	Mode 2
↓	MODE X	Mode 3
3 STAT	STAGES	Capacity stages
↓	X STAGE	Stage number
4 STAT	SETPOINT	Current operating set point
↓	MLAS X	Control modified leaving air temperature set point
↓	LAT X	Actual leaving air temperature
5 STAT	TEMPS	System Temperatures
↓	EAT X	Entering air temperature
↓	LAT X	Leaving air temperature
↓	CST X	Reset/Unoccupied cooling space temperature
6 STAT	PRESS	System pressures
↓	LCS1 X	Loss of charge switch lead circuit
↓	LCS2 X	Loss of charge switch lag circuit
7 STAT	POSITION	System position values
↓	ECON X	Changeover switch (aquastat)
↓	VLV X	Economizer circuit percent open
8 STAT	OVERRIDE	Unit override status
↓	ENBL X	Enable override (1 = yes, . = no)
↓	DSBL X	Disable override (1 = yes, . = no)

HISTORY		
KEYBOARD ENTRY	DISPLAY	COMMENTS
1 HIST	ALRMHIST	Alarm history
↓	ALARM X	Alarm X (Most recent alarm)
↓	ALARM X	Alarm X
↓	ALARM X	Alarm X
↓	ALARM X	Alarm X
↓	ALARM X	Alarm X

TEST		
KEYBOARD ENTRY	DISPLAY	COMMENTS
1 TEST	INPUTS	Factory/field test of inputs
↓	CHK STAT	Check 1 STAT for any input failures
2 TEST	OUTPUTS	Factory/field test of outputs
↓	VLV OPN	Economizer circuit open test
↓	VLV CLO	Economizer circuit close test
↓	IFC	Indoor fan test
↓	OFC	Outdoor fan test
↓	ULD 1	Unloader 1 test
↓	ULD 2	Unloader 2 test
3 TEST	COMP	Factory/field test of compressors
↓	COMP1	Compressor 1 test
↓	COMP2	Compressor 2 test

⚠ WARNING
 During test of compressors, each compressor will start and run for 10 seconds. Compressor service valves and the liquid line valve must be open. Energize compressor crankcase heaters for 24 hours prior to performing compressor tests.

4 TEST	EXIT TEST	Leave quick test
--------	-----------	------------------

Table 4 – Keyboard Directory (cont)

SERVICE		
KEYBOARD ENTRY	DISPLAY	COMMENTS
[1] [SRVC]	LOGON	Now enter password
[1] [1] [1] [1] [ENTR]	LOGGEDON	
When finished with configurations, log out as follows:		
[1] [SRVC]	LOGGEDON	Shows that configurations are available
[↓]	LOG OFF	
[ENTR]	LOGD OFF	Logged off okay. Configurations are again password protected
[2] [SRVC]	VERSION	Software version number
[↓]	XXX	Software version
[3] [SRVC]	FACT CFG	Factory configurations (requires password entry under [1] [SRVC], else displays DENIED)
[↓]	COMP X	Number of compressors
[↓]	UNLS X	Number of unloaders
[4] [SRVC]	FLD CFG	Field configuration (The [.] key disables the subfunction and the [1] key enables the subfunction.)
[↓]	RST X	Reset enable
[↓]	DMLM X	Demand limit enable
[↓]	ECON X	Economizer enable
[↓]	UCLG X	Unoccupied Cooling enable
[↓]	ECLK X	Electronic time clock enable
[5] [SRVC]	SRV CFG	Service configuration
[↓]	NONE	This device contains no service configuration parameters
[6] [SRVC]	VARIABLE	Service variables
[↓]	NONE	This device contains no service variables
[7] [SRVC]	ADDRESS	Network address
[↓]	ADDR X	Element address
[↓]	BUS X	Bus number

SET POINT		
KEYBOARD ENTRY	DISPLAY	COMMENTS
[1] [SET]	SETPOINT	System set points
[↓]	LAS X	Leaving air temperature set point
[2] [SET]	RESET	Reset set points
[↓]	RTS X	Reset temperature set point
[↓]	RLS X	Reset limit set point
[3] [SET]	DEMAND	Demand limit set points
[↓]	DL1 X	Demand limit set point 1
[↓]	DL2 X	Demand limit set point 2
[4] [SET]	TIME	Current time
[↓]	DAY.HH.MM	Current setting
[5] [SET]	UNOCCUPD	Unoccupied set points
[↓]	COOL X	Unoccupied cooling set point

SCHEDULE		
KEYBOARD ENTRY	DISPLAY	COMMENTS
[1] [SCHD]	OVRD	Number of hours to extend occupied period
[2] [SCHD]	PERIOD 1	Define time schedule period 1
[↓]	OCC X	Start of Occupied time
[↓]	UNO X	Start of Unoccupied time
[↓]	MON X	Monday flag (X = entry codes) (1 = yes, . = no)
[↓]	TUE X	
[↓]	WED X	
[↓]	THU X	
[↓]	FRI X	
[↓]	SAT X	
[↓]	SUN X	
[↓]	HOL X	Holiday flag
[3] [SCHD]		
[↓]		
[↓]		
[↓]		
[9] [SCHD]		
		Time periods 2-8 (same elements as period 1)

Display Functions

SUMMARY DISPLAY — Whenever the keyboard has not been used for 10 minutes, the display will automatically switch to an alternating summary display. This display has 4 parts, shown below, which alternate in continuous rotating sequence.

Display	Expansion
TUE 12:45	TODAY IS TUE, TIME IS 12:45
MODE 23	UNOCCUPIED HEATING
1 STAGE	NUMBER OF STAGES IS 1
2 ALARMS	THERE ARE 2 ALARMS DETECTED

STATUS FUNCTION — The status function shows the current status of alarm (diagnostic) codes, capacity stages, operating modes, set points, all measured system temperatures, pressure switch position, and economizer valve position. These subfunctions are defined on pages 12-14. Refer to Table 3 for additional information.

1 **STAT** (Alarms) — Alarms are messages that one or more faults have been detected. Each fault is assigned a code number which is reported with the alarm. (See Table 5 for code definitions.) The codes indicate failures that cause the unit to shut down, terminate an option (such as reset) or result in the use of a default value as set point.

Up to 8 alarm codes can be stored at once. To view them in sequence, press **1** **STAT** to enter the alarm displays and then press **↓** to move to the individual alarm displays. Press **EXPN** after a code has been displayed and the meaning of the code will scroll across the screen. See Example 1.

Example 1 — Reading Alarm Codes

KEYBOARD ENTRY	DISPLAY RESPONSE	COMMENTS
	TUE 12:45 MODE 25 0 STAGES 3 ALARMS	Keyboard has not been used for at least 9 minutes. Alternating summary display appears on screen
1 STAT	3 ALARMS	3 alarms detected
↓	ALARM 59	First alarm code
EXPN	LOSS OF CHARGE LEAD CIRCUIT	Explanation of alarm code
↓	ALARM 71	Second alarm code
EXPN	LEAVING AIR THERMISTOR FAILURE	Explanation of alarm code
↓	ALARM 81	Third alarm code
EXPN	RESET THERMISTOR FAILURE	Explanation of alarm code

When a diagnostic (alarm) code is stored in the display and the machine automatically resets, the code will be deleted. Codes for safeties which do not automatically reset will not be deleted until the problem is corrected and the unit is switched to STANDBY, then back to RUN.

2 **STAT** (Modes) — The operating mode codes are displayed to indicate the operating status of the unit at a given time. (See Table 5.)

The modes are explained below:

Initialization (20) — In this mode the unit checks the thermistors to verify they are within range and drives the hydronic economizer motor wide open and fully closed.

Temperature Reset (21) — This mode indicates that the unit is using temperature reset to adjust the set point and to control to the modified set point. The set point is modified based on space temperature.

Demand Limit (22) — This mode indicates the capacity of the unit is being limited by the Demand Limit control option. This mode is only available on units connected to the Carrier Comfort Network (CCN) or through the use of the external demand limit switches.

Unoccupied Cooling (24) — This mode indicates that the space temperature is above the Unoccupied Cooling set point and the unit is ON. When the space temperature falls below the set point the unit is turned OFF.

Standby (25) — The unit is being held in the standby mode either because the RUN/STANDBY switch is open or a set of relay contacts in series with the RUN/STANDBY switch is open.

Run (28) — Unit is operating.

To enter the MODE subfunction, depress **2** **STAT** and use the **↓** key to determine if more than one mode applies. See Example 2 to read current mode with expansion.

Example 2 — Reading Current Operating Modes

KEYBOARD ENTRY	DISPLAY RESPONSE	COMMENTS
	TUES 12:45 MODE 25 0 STAGES	Keyboard has not been used for at least 9 minutes. Alternating summary display appears on screen.
2 STAT	MODE	Mode subfunction of status function
↓	MODE 25	Mode 25 is in effect
EXPN	UNIT STANDBY	Explanation of code 25

3 **STAT** (Stages) — This subfunction displays the capacity stage number, from 1 to 6. See Table 6 for compressor loading sequence. To enter the STAGES subfunction, depress

3 **STAT** and use the **↓** key to display the stage number.

4 **STAT** (Set point) — This subfunction displays the modified leaving air set point and actual leaving air temperature. Modified leaving air set point will be the set point programmed in the SET function unless a temperature reset is in effect. If reset is in effect, the modified set point will be displayed.

To enter the set point subfunction, depress **4** **STAT**, then use the **↓** key to display the modified set point followed by the actual leaving air temperature.

Table 5 – Display Codes

OPERATING MODES	
Display	Description
20	Initialization
21	Temperature reset in effect
22	Demand limit in effect
24	Unoccupied cooling
25	Unit standby
27	Unoccupied mode
28	Run mode

ALARMS				
Display	Description	Action Taken By Control	Reset Method	Probable Cause
51	Compressor 2 failure	Lag circuit shut OFF	Manual	High pressure switch or high discharge gas temperature switch trip ON
55	Compressor 1 failure	Lead circuit shut OFF	Manual	
59	Loss of charge — lead circuit	Circuit 1 shut OFF	Manual	Low refrigerant charge or low pressure switch failure
60	Loss of charge — lag circuit	Circuit 2 shut OFF	Manual	
71	Leaving air thermistor failure	Unit shut OFF	Auto	Thermistor failure, or wiring error, or thermistor not connected to processor board
72	Entering air thermistor failure	Use default	Auto	
81	Reset thermistor failure	Stop reset	Auto.	
83	Economizer potentiometer failure	Hydronic economizer valve close	Manual	Potentiometer failure, wiring error, or potentiometer not connected to input terminals

NOTES:

1. All auto. reset failures that cause unit to stop will restart the unit when the error has been corrected.
2. All manual reset errors must be reset by moving the control switch to STANDBY and then to RUN.

Table 6 – Loading Sequences

50BJ/BK024,028,034,054 and 064

STAGE	COMPRESSOR NO. 1	UNLOADER NO. 1	UNLOADER NO. 2	COMPRESSOR NO. 2
0	OFF	OFF	OFF	OFF
1	ON	UNLOADED	UNLOADED	OFF
2	ON	LOADED	UNLOADED	OFF
3	ON	LOADED	LOADED	OFF
4	ON	UNLOADED	UNLOADED	ON
5	ON	LOADED	UNLOADED	ON
6	ON	LOADED	LOADED	ON

50BJ/BK044

STAGE	COMPRESSOR NO. 1	UNLOADER NO. 1	COMPRESSOR NO. 2
0	OFF	OFF	OFF
1	ON	UNLOADED	OFF
2	ON	LOADED	OFF
3	ON	UNLOADED	ON
4	ON	LOADED	ON

6 **STAT** (Pressure) — This subfunction displays the status of the loss of charge switches. The display will show CLOSED or OPEN for the loss of charge switch. To enter Pressure subfunction, depress **6** **STAT** then use the **↓** key to display loss of charge switches.

7 **STAT** (Position) — The position subfunction displays the current position of the hydronic economizer 3-way mixing valve. The changeover switch display will indicate ECON OFF (aquastat open, water temperature too high) or ECON ON (aquastat closed, water temperature suitable or cooling or economizer active). The valve position will be displayed as percent open. Use the **↓** key to display damper position.

NOTE: The position subfunction will not display unless the economizer function is enabled.

5 **STAT** (Temperature) — The temperature subfunction displays the readings at temperature sensing thermistors. To read a temperature, enter **5** **STAT**, then scroll to the desired temperature using the **↓** key. Table 4 shows the order of the readouts.

8 **STAT** (Override) — This subfunction displays the status of the Occupied/Unoccupied mode override. An override of the current operating mode is possible through the use of the local interface device or building supervisor.

To override a current operating mode, enter **8** **STAT** and then scroll to the desired override. See Example 3.

NOTE: Unit will remain in override until **CLR** **ENTR** is depressed or until force is cleared at the building supervisor.

Example 3 – Using the Override Subfunction

KEYBOARD ENTRY	DISPLAY RESPONSE	COMMENTS
8 STAT	OVERRIDE	Unit override status
↓	ENBL NO	Unit is operating normally in the unoccupied mode
1 ENTR	ENBL YES	Unit has been forced into the occupied mode
	FORCED	Display blinks while mode is forced
CLR ENTR	ENBL NO	Unit is once again operating normally in the unoccupied mode
↓	DSBL NO	Unit is operating normally in the occupied mode
1 ENTR	DSBL YES	Unit has been forced into the unoccupied mode
	FORCED	Display blinks while mode is forced
CLR ENTR	DSBL NO	Unit is once again operating normally in occupied mode

HISTORY FUNCTION

1 **HIST** — Displays the 5 latest alarms generated by the unit in the order of their occurrence, with the most recent alarm being first. If 5 alarms are displayed, the occurrence of a sixth alarm shifts the first alarm off the display.

TEST FUNCTION — The Test function operates the Quick Test diagnostic program. When the unit is in STANDBY mode, the Test subfunctions will energize the fans, unloaders, compressors and hydronic economizer actuator motor. The compressors will energize for 10 seconds. The subfunctions are explained below. Refer to Table 4 for all the elements in the subfunction.

1 **TEST** — Displays the status of all inputs.

2 **TEST** — Tests the outputs from the processor, except for compressors.

3 **TEST** — Tests the compressors.

4 **TEST** — Takes the unit out of Quick Test.

NOTE: The Quick Test energizes the alarm light. The alarm light will remain energized as long as the unit is in Quick Test.

To reach a particular test, enter its subfunction number and then scroll to the desired test with the **↓** key. A test can be terminated by pressing **↓** key. Pressing the **↓** key after a test has started will advance the system to the next test, whether the current one is operating or has timed out. Once in the next step, you may start the test by pressing **ENTR** or advance past it by pressing **↓**. While the unit is in Quick Test, you may access another display or function by depressing the appropriate keys; however, the unit will remain in the Quick Test function until **4** **TEST** is entered, or, if the keyboard is not used for 9 minutes, the unit will automatically leave the Quick Test function. See Example 4.

Example 4 – Using Quick Test

KEYBOARD ENTRY	DISPLAY RESPONSE	COMMENTS
3 TEST	COMP	Factory/field test of compressors subfunction of test function (Compressor 1 test)
↓	COMP1	
ENTR	COMP1	Pressing ENTR starts the test; when the compressor should be running the display shows COMP1
↓	COMP1	If the test is allowed to time out, the display will show COMP1
↓	COMP2	Pressing the down arrow key advances the system to compressor 2 test
4 TEST	EXIT TEST	If no other test is desired, exit quick test

Programming Functions

SERVICE FUNCTION — The Service function allows the operator to verify factory configurations and read or change field configurations. The Service subfunctions are listed below. (See Table 4 for details.) Refer to Table 7 for configuration option default values.

1 **SRVC** — The operator must use this subfunction to log on before performing any other subfunction, and to log off after completing service subfunctions. See Example 5.

2 **SRVC** — Used to verify software version.

Example 5 – Logging On and Logging Off Service Function

KEYBOARD ENTRY	DISPLAY RESPONSE	COMMENTS
TO LOG ON: 1 SRVC	LOGON	Ready for password to be entered
1 1 1 1 ENTR	LOGGED ON	Operator can now use service functions
TO LOG OFF: 1 SRVC	LOGGED ON	Configurations are available to operator
↓	LOG OFF	Ready for operator to log off
ENTR		Logged off — password protection enabled

Table 7 – Service Configuration Ranges and Defaults

SUBFUNCTION NUMBER	CONFIGURATION VALUE	RANGE	FACTORY DEFAULT
3	Number of compressors Number of unloaders: Size 024-034, 054, 064 Size 044	2 1-2 1	2 2 1
4	Space temperature reset Demand limit Economizer Unoccupied cooling Electronic time clock	Enable/Disable Enable/Disable Enable/Disable Enable/Disable Enable/Disable	Disable Disable Disable Disable Enable
7	Element address Bus number	0-239 0-239	0 0

3 **SRVC** — Used to verify factory configurations (number of compressors and unloaders). See Example 6.

4 **SRVC** — Used to enable the unit for reset, Demand Limit, hydronic economizer, Unoccupied Cooling, or electronic time clock. See Example 7.

NOTE: The **1** key is used to enable or turn on certain functions, the **CLR** or **•** key is used to disable these functions. When the **•** key is pressed, the display will show 0.

Example 6 – Reading Factory Configurations

KEYBOARD ENTRY	DISPLAY RESPONSE	COMMENTS
3 SRVC	FACT CFG	Factory configuration subfunction of service function
↓	COMP2	Number of compressors is 2
EXPN	NUMBER OF COMPRESSORS IS 2	Explanation is scrolled across screen
↓	UNLS 2	Number of unloaders is 2

Example 7 – Reading and Changing Field Configurations

KEYBOARD ENTRY	DISPLAY RESPONSE	COMMENTS
4 SRVC	FLD CFG	Field Configuration subfunction of service function
↓	RST NO	Temperature reset is disabled
1 ENTR	RST YES	Temperature reset is enabled
CLR ENTR	RST NO	Temperature reset is disabled
↓	DMLM NO	Demand limit is disabled
↓	ECON NO	Hydronic economizer is disabled
1 ENTR	ECON YES	Hydronic economizer is enabled

5 **SRVC** — Unit contains no service configuration parameters.

6 **SRVC** — Unit contains no service variables.

7 **SRVC** — Used to assign network addresses when unit is connected to CCN. See Example 8.

NOTE: Element address and bus number are determined by the building system designer.

Example 8 – Assigning Network Addresses

KEYBOARD ENTRY	DISPLAY RESPONSE	COMMENTS
7 SRVC	ADDRESS	Network address subfunction of service function
↓	ADDR 0	Element address = 0
1 ENTR	ADDR 1	Element address = 1
↓	BUS 0	Bus number = 0
2 ENTR	BUS 2	Bus number = 2

SET POINT FUNCTION — Set points are entered through the keyboard. Set points can be changed within the upper and lower limits, which are fixed. See Table 8.

1 [SET] — Displays leaving air temperature set point.

2 [SET] — Displays temperature reset set point.

3 [SET] — Displays Demand Limit set points.

4 [SET] — Displays time of day and day of week.

5 [SET] — Displays Unoccupied Cooling set points.

Reading and Changing Set Points — Example 9 shows how to read and change system set points. Other set points can be changed by following the same procedure. Refer to Table 4 for the display sequence of set points in each subfunction. To adjust any parameter after enabling a function, depress \downarrow key until desired parameter is displayed. Key in new value and depress [ENTR]. If input is within the allowable range, the display will show the parameter and new value. If the input is not within the allowable range, the old value will still be displayed.

Example 9 — Reading and Changing System Set Points

KEYBOARD ENTRY	DISPLAY RESPONSE	COMMENTS
1 [SET]	SETPOINT	System set points
\downarrow	LAS 55	Present leaving air set point is 55 F
5 0	LAS 50	Key in 50 and depress [ENTR]. Display shows new leaving air set point is 50 F, which is within the allowable range
4 0 [ENTR]	LAS 50	Key in 40 and depress [ENTR]. Display still shows leaving air set point as 50 because 40 is not within the allowable range. See Table 8 for allowable ranges

NOTE: The subfunctions to change reset set points (2 [SET]), Demand Limit set points (3 [SET]), Unoccupied set points (5 [SET]) are performed in the same manner as Example 9.

Table 8 — Set Point Ranges and Defaults

SET POINT	RANGE	FACTORY DEFAULT
Leaving Air Temperature Set Point (F)	45- 70	55
Demand Limit Set Point No. 1 (%)	50-100	100
Demand Limit Set Point No. 2 (%)	0- 49	49
Reset Temperature Set Point (F)	40- 80	70
Reset Limit Set Point (F)	0- 20	10
Unoccupied Cooling Set Point (F)	70-100	85

Reading and Changing Time Display — Time is entered and displayed in 24-hour time. The day of the week is entered as a number: 1 = MON, 2 = TUE...7 = SUN. The \cdot key is used as the colon when entering time. See Example 10.

Example 10 — Setting Time of Day and Day of Week

KEYBOARD ENTRY	DISPLAY RESPONSE	COMMENTS
4 [SET]	TIME	Time display subfunction of set point function
\downarrow	MON 16.00	Current setting is Monday, 4:00 p.m
2 \cdot 1 3 \cdot 0 5 [ENTR]	TUE 13.05	New setting of Tuesday, 1:05 p.m is entered and displayed

SCHEDULE FUNCTION — This function provides a means to automatically switch the unit from an Occupied mode to an Unoccupied mode.

Occupied/Unoccupied time of day scheduling is provided by an internal electronic 7-day clock. This eliminates the need for the accessory time control panel. (On stand-alone units, field-installed contact closures allow an external time clock to be used (instead of an internal time clock) to enable and disable the Occupied mode. The internal time clock must be disabled if using an external clock.

The schedule consists of from one to 8 Occupied time periods, set by the operator. These time periods can be flagged to be in effect or not in effect on each day of the week. The day begins at 00.00 and ends at 24.00. The unit will be in Unoccupied mode unless a scheduled time period is in effect. If an Occupied period is to extend past midnight, it must be programmed in the following manner: Occupied period must end at 00.00 hours (midnight); a new Occupied period must be programmed to begin at 00:00 hours on the next day. The Occupied period must end at 00.00 hours in order for the unit to stay in the Occupied mode past midnight, but not remain locked in the Occupied mode.

The time schedule can be overridden to keep the unit in the Occupied mode for one, 2, 3 or 4 hours on a one time basis.

The unit may be configured for an applicable holiday/shutdown schedule. This function can only be utilized if the unit is connected to the Carrier Comfort Network. The network will send a holiday message (flag) to the unit on the appropriate holiday. The unit will then utilize the schedule that has been set up for the holiday period. The unit will automatically return to its normal schedule after the holiday period is complete.

Figure 10 shows an example for an office building with the unit operating on a set point schedule. The schedule is based on building occupancy with 3-hour off-peak cool-down period from midnight to 3 a.m. following weekend shutdown. To learn how this sample schedule would be programmed, see Example 11.

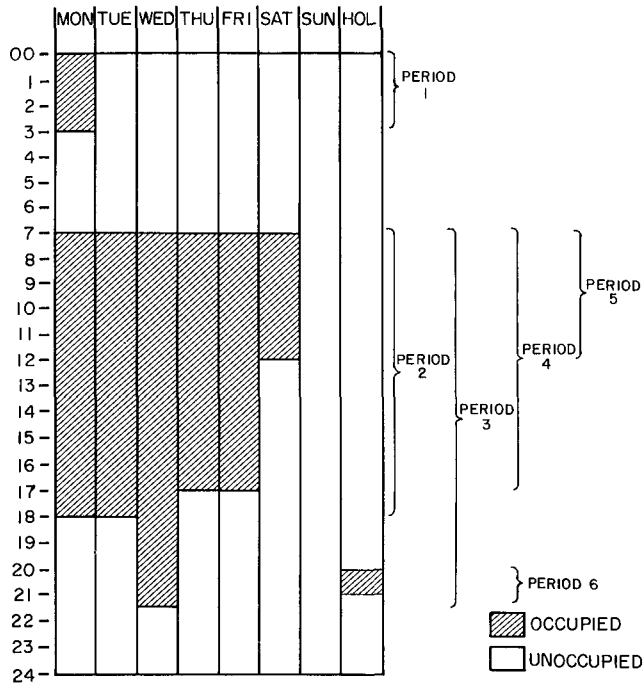

Fig. 10 – Sample Time Schedule

Example 11 – Using the Schedule Function (cont)

KEYBOARD ENTRY	DISPLAY RESPONSE	COMMENTS
PROGRAMMING PERIOD 2:		
For this example, period 2 is used on Monday and Tuesday		
[3] [SCHD]	PERIOD 2	Define scheduling period 2
[↓]	OCC 00 00	Start of occupied time
[7] [.] [0] [0] [ENTR]	OCC 7.00	Occupied time will start at 7:00 a m
[↓]	UNO 00 00	Start of unoccupied time (end of period) for this example, period 2 should end at 18:00 (6:00 p m)
[1] [8] [.] [0] [0] [ENTR]	UNO 18 00	Period 2 ends at 18:00 (6:00 p.m.)
[↓]	MON NO	Monday is not flagged for period 2 To put period 2 into effect on Monday, Monday must be flagged yes
[1] [ENTR]	MON YES	Monday is now flagged for period 2 to be in effect
[↓]	TUE NO	Tuesday is not flagged for period 2 To put period 2 into effect on Tuesday, Tuesday must be flagged yes
[1] [ENTR]	TUE YES	Tuesday is now flagged for period 2 to be in effect
[↓]	WED YES	For this example, period 2 is to be in effect only on Monday and Tuesday. All other days must be checked to be sure that they are flagged no If a day is flagged yes, change to no
[.] [ENTR]	WED NO	Wednesday is now flagged no for period 2

Example 11 – Using the Schedule Function

KEYBOARD ENTRY	DISPLAY RESPONSE	COMMENTS
PROGRAMMING PERIOD 1:		
[2] [SCHD]	PERIOD 1	Define schedule period 1
[↓]	OCC 00 00	Start of occupied time. For this example, first period should start here (at midnight) so no entry is needed
[↓]	UNO 00 00	Start of unoccupied time (end of period) For this example, period 1 should end at 3:00 a m
[3] [.] [0] [0] [ENTR]	UNO 3 00	Period 1 ends at 3:00 a m
[↓]	MON NO	Monday is not flagged for period 1 To put period 1 into effect on Monday, Monday must be flagged yes
[1] [ENTR]	MON YES	Monday is now flagged for period 1 to be in effect
[↓]	TUE YES	For this example, period 1 is to be in effect on Monday only All other days must be checked to be sure that they are flagged no If any day is flagged yes, change to no
[.] [ENTR]	TUE NO	Tuesday is now flagged no for period 1

Example 11 – Using the Schedule Function (cont)

KEYBOARD ENTRY	DISPLAY RESPONSE	COMMENTS
PROGRAMMING PERIOD 3:		
For this example, Period 3 is used on Wednesday only.		
4 [SCHD]	OCC 00 00	Start of occupied time
7 . 0 0 [ENTR]	OCC 7 00	Occupied time will start at 7:00 a.m.
↓	UNO 00.00	Start of unoccupied time (end of period 3). For this example, period 3 should end at 21:30 (9:30 p.m.)
2 1 . 3 0 [ENTR]	UNO 21 30	Period 3 ends at 21:30 (9:30 p.m.)
↓	MON NO	Check to be sure that Monday and Tuesday are flagged no for period 3
↓	TUE NO	
↓	WED NO	Wednesday is flagged no Change to yes
1 [ENTR]	WED YES	Wednesday is now flagged yes for period 3
↓	THU NO	Check to be sure that all other days are flagged no
↓	FRI NO	
↓	SAT NO	
↓	SUN NO	
↓	HOL NO	

Period 4 and 5 can be programmed in the same manner, flagging Thursday and Friday yes for period 4 and Saturday yes for period 5. For this example, periods 7 and 8 are not used; they should be programmed OCC 00 00, UNO 00 00

NOTE: When a day is flagged yes for 2 overlapping periods, occupied time will take precedence over unoccupied time. Occupied times can overlap in the schedule with no consequence

To extend an occupied mode beyond its normal termination for a one-time schedule override, program as shown below:

1 [SCHD]	OVRD 0	Override is set for 0; enter the number of hours of override desired
3 [ENTR]	OVRD 3	Unit will now remain in Occupied mode for an additional 3 hours

Example 11 – Using the Schedule Function (cont)

KEYBOARD ENTRY	DISPLAY RESPONSE	COMMENTS
PROGRAMMING PERIOD 6:		
For this example, Period 6 is used for holiday only.		
5 [SCHD]	OCC 00 00	Start of occupied time
2 0 . 0 0 [ENTR]	OCC 20 00	Occupied time will start at 20:00 (8:00 p.m.)
↓	UNO 00 00	Start of unoccupied time (end of period 6). For this example, period 6 should end at 21:00 (9:00 p.m.)
2 1 . 0 0 [ENTR]	UNO 21 00	Period 6 ends at 21:00 (9:00 p.m.)
↓	MON NO	Check to be sure that Monday through Sunday are flagged no for period 6
↓	TUE NO	
↓	WED NO	
↓	THU NO	
↓	FRI NO	
↓	SAT NO	
↓	SUN NO	
↓	HOL NO	Holiday is flagged no. Change to yes
1 [ENTR]	HOL YES	Holiday is now flagged yes for period 6

CONTROL OPERATING SEQUENCE

Cooling — When the unit enters the Occupied mode, the indoor fan will activate, and the control will compare the leaving air temperature to the leaving air set point. If leaving air is above set point, the control will turn on capacity steps in 4 or 6 stages of compression (depending on unit size) to meet the load. The rate at which capacity stages are turned on and off depends on the differential between leaving air actual temperature and set point, the rate of change of leaving air and return air temperatures, recent load history, etc.

On units with hydronic economizer, the unit will go through a 3-minute initialization period when it enters the Occupied mode. During initialization, the economizer 3-way valve will open and close the economizer circuit before the unit goes into the cooling mode. This allows the processor to program the position of the valve at both extremes, so that it can properly modulate the economizer function during cooling. The indoor fan will not be activated until completion of the initialization process.

An aquastat is utilized with the hydronic economizer to determine if the condenser water is cool enough to provide free cooling. The aquastat set point and differential are adjustable and must be set at installation. When the unit goes into the cooling mode, if the condenser water temperature is below the aquastat set point and differential adjustment, control will attempt to satisfy the cooling load with the economizer before bringing on any stages of mechanical cooling.

Aquastat set point range is 15 - 90 F. The differential adjustment is 3.5 - 16 F.

When the first stage of compression is turned on, the relay module will close a set of contacts between terminals 1 and 2 on TB5 (024 - 034 units) or TB6 (044 - 064 units) to activate the remote condenser fans for 50BK applications. The low-pressure switches are bypassed during the first 2.5 minutes of operation of each compressor, to assist in low-ambient starting situations.

Units Equipped With Temperature Reset —

Temperature reset is a means for preventing overcooling at light loads, while keeping air circulation at reasonable levels. The effect is to reset the leaving air set point upward, as the conditioned space temperature drops below a predetermined temperature level. The leaving air set point is raised 0.33°F for every degree the space temperature drops below the reset set point. The reset set point is equal to the space temperature at which temperature reset is to begin. The maximum reset set point is adjusted by setting the reset limit to the maximum amount of reset desired.

Units Equipped With External Time Clock

— When a 24-volt signal is sent to Terminal 1 of TB3 (024 - 034 units) or Terminal 21 of TB5 (044 - 064 units), the unit enters the Occupied mode. When signal is removed, the unit enters the Unoccupied mode. This signal will override any Unoccupied schedule programmed into the internal clock. However, it cannot override an Occupied schedule. If the external clock is intended to be the permanent control, then the internal clock should be disabled (4 SRVC).

Unoccupied Cooling — The purpose of Unoccupied Cooling is to provide a means for cooling a space before it exceeds some predetermined temperature during the Unoc-

cupied mode. The unit will enter the Occupied mode at 1 degree above the Unoccupied cooling space temperature set point and will reenter the Unoccupied mode at 1 degree below the Unoccupied Cooling space temperature set point.

Demand Limit — Two step Demand Limit is available for the purpose of limiting the number of stages of cooling allowed at a particular time. This is typically used to reduce electrical utility demand charges at peak power consumption periods of the day.

When connected to the Carrier Comfort Network (CCN), demand limiting may be accomplished through the Loadshed option of the CCN instead of the demand limiter. When the Loadshed option issues a redline alert to the controller, first stage demand limit will be used. When the Loadshed option issues a shed command to the controller, second stage demand limit will be used.

START-UP

Initial Check — Prepare the unit for operation in the normal manner. Refer to the base unit Installation, Start-Up and Service Instructions.

1. Put the RUN/STANDBY switch in the STANDBY position. Close the indoor fan circuit breaker, which will energize the control circuit and the crankcase heaters. Crankcase heaters must operate for at least 24 hours before actually running either compressor.
2. Normal operation of the controls is indicated by blinking red and green lights on the processor module and the relay modules. Using the local interface device, verify that no alarms have been detected.
3. To allow easy checkout of initial operation, the controls are pre-set with a 55 F leaving air set point. Put the unit temporarily in the Occupied mode by adding a jumper from terminal 11 to terminal 1 on TB3 (024 - 034 units), or terminal 20 to terminal 21 on TB5 (044 - 064 units). If the unit is water cooled, ensure that water is flowing in the condenser circuits. If it is a condenserless unit, ensure that condenser control circuit wiring is complete at TB5 (024 - 034 units) or TB6 (044 - 064 units).
4. If unit has hydronic economizer, program the controls at the local interface device (4 SERW). See Example 7 for details.
5. To put the unit on line, close compressor circuit breakers. Put the RUN/STANDBY switch in the RUN position. If the unit does not have hydronic economizer, the indoor fan will start immediately. If the supply air is higher than 55 F, the unit will proceed to stage up.
6. If unit has hydronic economizer, it will go through a 3-minute initialization period where the economizer 3-way mixing valve actuator motor will drive full open and back to full closed. After the 3-minute period, the indoor fan will start and the unit will stage up to meet the 55 F set point. If the condenser water is suitable, it will try to satisfy the load using the economizer only before bringing on any compressors.
7. Shut down the unit by putting the RUN/STANDBY switch in STANDBY position.

Quick Test — The Test function provides a check on control inputs and outputs, and can only be conducted when the unit is in the STANDBY mode. The alarm light will be on at all times when in the Test function, and will remain on even if another function (i.e. Status) is entered during the test. The alarm light will go off only when the test is terminated. Always terminate the test by the exit procedure (depressing **4** , then **TEST**).

The failure of any input will generate an alarm, so the input check simply directs the user to check for alarms in the Status function. Note that the Test function remains active even when searching the Status function.

The output check allows the user to confirm the operation of all fans, compressors, unloaders, and the economizer 3-way mixing actuator motor. The test is performed in two steps for each component: the **↓** key will cause the component name to be displayed, and depressing **ENTR** after 2 seconds will cause the component to activate. To terminate the test on a component and step to the next component, simply depress the **↓** key. It is not necessary to activate a component in order to step to the next component. See Table 9.

If it is desired to activate the compressor during Quick Test, verify that service valves are open, circuit breakers are closed, and that all the normal preparatory steps have been taken, per the unit installation instructions. Operating time for the compressors is limited to 10 seconds during Quick Test. If it is not desired to activate the compressors, the compressor circuit breakers can be opened, and operation of the compressor contactors can be verified when **ENTR** is depressed.

Table 9 – Quick Test of Outputs

KEYBOARD ENTRY	DISPLAY RESPONSE	COMMENTS
2 TEST	OUTPUTS	Field test of outputs
↓	VLV OPN	Economizer circuit open check
ENTR		This is the signal to the 3-way valve actuator motor to open the economizer circuit. This step will be ignored if the economizer is not enabled in 4 SRVC
↓	VLV CLO	Economizer circuit close test
ENTR		Verify circuit closes
↓	IFC	Supply fan test
ENTR		Verify indoor fan is activated

⚠ WARNING

If the indoor fan is not activated at this step, it will automatically activate at the first subsequent activated step of the Quick Test. It will remain ON for the duration of the test.

↓	OFC	Outdoor fan test, 50BK units only. This is the only stage of processor controlled fans
↓	ENTR	Verify outdoor fan starts
↓	ULD1	Unloader 1 test
↓	ENTR	Check valve stem with a knife blade or screwdriver to verify the existence of a magnetic field
↓	ULD2	Unloader 2 test. NOTE: This step is ignored on 044 units
↓	ENTR	For 024 - 034, 054, and 064 units, follow the same procedure as unloader 1 test
3 TEST	COMP	Field test of compressors
↓	COMP1	Compressor no. 1 test
↓	ENTR	Verify compressor contactors are operational. Operating time for compressors is limited to 10 seconds during Quick Test
↓	COMP2	Compressor 2 test
↓	ENTR	Verify compressor contactors are operational. Operating time for compressors is limited to 10 seconds during Quick Test
4 TEST	EXIT TEST	
↓	ENTR	Terminate Quick Test

IMPORTANT: Always exit Quick Test before proceeding to another function. If there is no keypad activity for 9 minutes, the controls will automatically exit Quick Test.

TROUBLESHOOTING

▲ CAUTION

Turn controller power OFF before servicing the controls. This is to ensure safety and prevent damage to the controller.

Self Health Check — The PSIO and DSIO modules both perform continuous diagnostic evaluations of the condition of the hardware. Proper operation of these modules is indicated by LEDs (light emitting diodes).

RED LED:

Blinking continuously at a 3 to 5-second rate indicates proper operation

Lit continuously indicates a problem requiring replacement of the module

Off continuously indicates the power should be checked. If there is no input power, check fuses. If fuse is bad, check for shorted secondary of transformer, or for bad module.

GREEN LED: (On a PSIO, this is the green LED closest to the COMM connectors.) The green LED should always be blinking when power is on; it indicates that the modules are communicating properly. If a green LED is not blinking, check the red LED. If the red LED is normal, check the module address switches. The proper addresses are:

PSIO (Processor Module) — 00
DSIO (Relay Module) — 19

If all modules indicate a communication failure, check the COMM plug on the PSIO module for proper seating. If a good connection is assured and the condition persists, replace the PSIO module.

If only a DSIO module indicates a communication failure, check the COMM plug on that module for proper seating. If a good connection is assured and the condition persists, replace the DSIO module.

Control Diagnostic Information — Alarms are a signal that a fault has been detected. The diagnostic routine checks all inputs every 3 seconds, and upon detecting a fault, activates the alarm message and the alarm light. Refer to Table 5 for alarm codes and a brief description of the possible causes.

Codes 51 and 55: Compressor Failure — If the controls are calling for a compressor to run, but the high-pressure switch, compressor internal thermostat (024 - 034 units) or discharge gas thermostat (044 - 064 units) is open, the compressor will be locked out and the appropriate alarm activated. When the fault has been corrected, the compressor circuit must be reset by putting the unit into STANDBY and then back into RUN.

Codes 59 and 60: Low-Pressure Switch — This fault indicates that the low-pressure switch (LPS) is open. When this happens, the compressor in that circuit is shut down and locked out. The low-pressure switch will automatically reset when the circuit pressure rises, but the controls must be reset by going to STANDBY and then back to RUN. When the controls are reset, the alarm message is cancelled and the alarm light de-activates.

To assist in winter start conditions, the low-pressure switches are ignored by the controls during the first 2.5 minutes of compressor operation. (This eliminates the need for the accessory winter start package.) However, if a low-pressure switch is open prior to a compressor starting, this will be recognized as a loss of charge condition and the compressor will be prevented from starting. Also, a low-pressure switch that opens after the 2.5 minute delay must remain open for 30 seconds before the controls will recognize it as a fault.

Opening of the low-pressure switch is usually due to low refrigerant charge, but could be due to other reasons such as low airflow, faulty TXV, or liquid line obstruction.

Codes 71 to 81: Thermistor Failure — All thermistors are routinely checked to verify that their resistance is within normal limits. Any thermistor reading low resistance (or shorted) will cause an alarm, and display 245.0 in the System Temperature portion of the Status function. Any thermistor reading high resistance (or open) will cause an alarm, and display -40.1 or -10.0 in the System Temperature portion of the Status function. All thermistor alarms will clear automatically when the fault is corrected. See Tables 10 and 11 for thermistor resistance.

LEAVING AIR THERMISTOR FAILURE (71) — When a fault is detected in the leaving air thermistor, compressors are locked out and the unit capacity stage set to zero. The economizer (if equipped) will become inactive and enter the full bypass position. The indoor fan will continue to run to provide ventilation. (The leaving air thermistor is a 5 K resistor.)

ENTERING AIR THERMISTOR FAILURE (72) — When a fault is detected in the entering air thermistor (5 K resistor), the unit will continue to run and attempt to meet the leaving air set point. However, the ability to respond properly to changing load conditions will be compromised until the fault is corrected. (The entering air thermistor is a 5 K resistor.)

RESET/UNOCCUPIED COOLING THERMISTOR FAILURE (81) — When a fault is detected in this thermistor, the reset and/or Unoccupied Cooling functions will be disabled. The unit will function normally in all other respects. (The Reset/Unoccupied cooling thermistor is a 10 K resistor.)

Code 83: Economizer Potentiometer Failure — If a fault is detected in the economizer valve motor potentiometer or associated wiring, the valve will move to the full bypass position, the economizer will become inactive and an alarm will be generated. After correction of the fault, reset the controls by moving the RUN/STANDBY switch to STANDBY and back to RUN.

**Table 10 – Thermistor Resistance vs Temperature Values for
Leaving Air Thermistor and Entering Air Thermistor (5 K at 25 C Resistors)**

RESISTANCE (Ohms)	TEMP (F)	RESISTANCE (Ohms)	TEMP (F)	RESISTANCE (Ohms)	TEMP (F)	RESISTANCE (Ohms)	TEMP (F)	RESISTANCE (Ohms)	TEMP (F)
98010	-25	19392	26	4976	77	1614	128	570	179
94707	-24	18843	27	4855	78	1582	129	560	180
91522	-23	18311	28	4737	79	1550	130	551	181
88449	-22	17796	29	4622	80	1519	131	542	182
85485	-21	17297	30	4511	81	1489	132	533	183
82627	-20	16814	31	4403	82	1459	133	524	184
79871	-19	16346	32	4298	83	1430	134	516	185
77212	-18	15892	33	4195	84	1401	135	508	186
74648	-17	15453	34	4096	85	1373	136	501	187
72175	-16	15027	35	4000	86	1345	137	494	188
69790	-15	14614	36	3906	87	1318	138	487	189
67490	-14	14214	37	3814	88	1291	139	480	190
65272	-13	13833	38	3726	89	1265	140	473	191
63133	-12	13449	39	3640	90	1239	141	467	192
61070	-11	13084	40	3556	91	1214	142	461	193
59081	-10	12730	41	3474	92	1189	143	456	194
57162	-9	12387	42	3395	93	1165	144	450	195
55311	-8	12053	43	3318	94	1141	145	444	196
53526	-7	11730	44	3243	95	1118	146	439	197
51804	-6	11416	45	3170	96	1095	147	434	198
50143	-5	11111	46	3099	97	1072	148	429	199
48541	-4	10816	47	3031	98	1050	149	424	200
46996	-3	10529	48	2964	99	1028	150	419	201
45505	-2	10250	49	2898	100	1007	151	415	202
44066	-1	9979	50	2835	101	986	152	410	203
42678	0	9717	51	2774	102	965	153	405	204
41339	1	9461	52	2713	103	945	154	401	205
40047	2	9213	53	2655	104	925	155	396	206
38800	3	8973	54	2598	105	906	156	391	207
37596	4	8739	55	2542	106	887	157	386	208
36435	5	8511	56	2488	107	868	158	382	209
35313	6	8291	57	2436	108	850	159	377	210
34231	7	8076	58	2385	109	832	160	372	211
33185	8	7868	59	2335	110	815	161	366	212
32176	9	7665	60	2286	111	798	162	361	213
31201	10	7468	61	2238	112	782	163	356	214
30260	11	7277	62	2192	113	765	164	350	215
29351	12	7091	63	2147	114	749	165	344	216
28472	13	6911	64	2103	115	734	166	338	217
27624	14	6735	65	2060	116	719	167	332	218
26804	15	6564	66	2018	117	705	168	325	219
26011	16	6399	67	1977	118	690	169	318	220
25245	17	6237	68	1937	119	677	170	311	221
24505	18	6081	69	1898	120	663	171	304	222
23789	19	5929	70	1860	121	650	172	297	223
23096	20	5781	71	1822	122	638	173	289	224
22427	21	5637	72	1786	123	626	174	282	225
21779	22	5497	73	1750	124	614	175		
21153	23	5361	74	1715	125	602	176		
20547	24	5229	75	1680	126	591	177		
19960	25	5101	76	1647	127	581	178		

**Table 11 – Thermistor Resistance vs Temperature Values for
Temperature Reset/Unoccupied Cooling Thermistor (10 K at 25 C Resistors)**

RESISTANCE (Ohms)	TEMP (F)	RESISTANCE (Ohms)	TEMP (F)	RESISTANCE (Ohms)	TEMP (F)	RESISTANCE (Ohms)	TEMP (F)	RESISTANCE (Ohms)	TEMP (F)
173631	-30	38309	22	10698	74	3603	126	1410	178
168222	-29	37304	23	10459	75	3533	127	1386	179
162998	-28	36329	24	10227	76	3466	128	1363	180
157954	-27	35382	25	10000	77	3400	129	1341	181
153083	-26	34463	26	9779	78	3335	130	1319	182
148378	-25	33571	27	9563	79	3272	131	1297	183
143833	-24	32704	28	9353	80	3210	132	1276	184
139442	-23	31863	29	9148	81	3150	133	1255	185
135200	-22	31046	30	8948	82	3090	134	1234	186
131101	-21	30252	31	8754	83	3033	135	1214	187
127139	-20	29481	32	8563	84	2976	136	1195	188
123310	-19	28732	33	8378	85	2920	137	1175	189
119609	-18	28005	34	8197	86	2866	138	1156	190
116031	-17	27298	35	8021	87	2813	139	1138	191
112571	-16	26611	36	7849	88	2761	140	1119	192
109226	-15	25943	37	7681	89	2710	141	1101	193
105992	-14	25295	38	7517	90	2660	142	1084	194
108863	-13	24664	39	7357	91	2611	143	1066	195
99837	-12	24051	40	7201	92	2564	144	1049	196
96910	-11	23456	41	7049	93	2517	145	1033	197
94078	-10	22877	42	6900	94	2471	146	1017	198
91339	-9	22313	43	6755	95	2426	147	1000	199
88687	-8	21766	44	6613	96	2383	148	985	200
86122	-7	21234	45	6475	97	2340	149	969	201
83638	-6	20716	46	6340	98	2298	150	954	202
81235	-5	20212	47	6209	99	2256	151	939	203
78908	-4	19722	48	6080	100	2216	152	925	204
76655	-3	19246	49	5954	101	2176	153	910	205
74474	-2	18782	50	5832	102	2138	154	896	206
72362	-1	18332	51	5712	103	2100	155	882	207
70317	0	17893	52	5595	104	2063	156	869	208
68336	1	17466	53	5481	105	2026	157	855	209
66417	2	17050	54	5369	106	1991	158	842	210
64558	3	16646	55	5260	107	1956	159	829	211
62757	4	16253	56	5154	108	1922	160	817	212
61012	5	15870	57	5050	109	1888	161	804	213
59321	6	15497	58	4948	110	1855	162	792	214
57682	7	15134	59	4849	111	1823	163		
56094	8	14780	60	4752	112	1791	164		
54555	9	14436	61	4657	113	1760	165		
53062	10	14101	62	4564	114	1730	166		
51616	11	13775	63	4474	115	1700	167		
50213	12	13457	64	4385	116	1671	168		
48853	13	13148	65	4299	117	1643	169		
47534	14	12846	66	4214	118	1615	170		
46255	15	12553	67	4132	119	1587	171		
45014	16	12267	68	4051	120	1560	172		
43810	17	11988	69	3972	121	1534	173		
42643	18	11717	70	3895	122	1508	174		
41510	19	11452	71	3819	123	1483	175		
40411	20	11194	72	3745	124	1458	176		
39344	21	10943	73	3673	125	1434	177		

UNIT TROUBLESHOOTING

SYMPTOMS	POSSIBLE CAUSE	CORRECTIVE ACTION
Unit does not run	PIC control is OFF	Check for correct power or blown fuses. Correct any deficiencies.
	Faulty connections	Check LED's on control module (PSIO) If LED is not solidly illuminated, check for loose connections. If all wires and connectors are secure, replace PSIO module.
	PIC control has incorrect time	Verify control shows correct time. If incorrect, enter correct time.
No cooling	Incorrect reading from Space Temperature Sensor, Leaving Air Temperature Sensor, or Entering Air Temperature Sensor	Check status of sensor readings for accuracy. Replace sensor if defective.
	Bad set point	Check for proper cooling set point. Reset set point if necessary.
Overcooling	Incorrect reading from Space Temperature Sensor, Leaving Air Temperature Sensor, or Entering Air Temperature Sensor	Check status of sensor readings for accuracy. Replace sensor if defective.
	Bad set point	Check for proper cooling set point. Reset set point if necessary.

UNIT TROUBLESHOOTING (cont)

SYMPTOMS	POSSIBLE CAUSE	CORRECTIVE ACTION
Sensor not reading correctly	Loose connections	Verify all connections are secure
	Sensor out of calibration	Voltage type sensors may be calibrated using manufacturer's instructions
	Defective sensor	If a sensor cannot be calibrated and its reading is considered unacceptable, replace sensor. Once sensor is replaced, verify sensor is reading correctly
Compressor does not run	Power line open	Reset circuit breaker.
	Control circuit breaker opens	Check control circuit for ground or short. Reset breaker.
	Safety thermostat tripped	Move RUN/STANDBY switch to STANDBY, then back to RUN
	Tripped power breaker	Check the controls. Find cause of trip and reset breaker.
	Loose terminal connection	Check connections.
	Improperly wired controls	Check wiring and rewire.
	Low line voltage	Check line voltage — determine location of voltage drop and remedy deficiency
	Compressor motor defective	Check motor winding for open or short. Replace compressor, if necessary.
Compressor shuts down on high-pressure control	Seized compressor	Replace compressor.
	High-pressure control erratic in action	Replace control switch
Compressor shuts down on low-pressure control	Compressor discharge valve partially closed	Open valve, or replace if defective
	Air in system	Purge
	Condenser fans not running	Check fans, motors and contactors.
	Blocked coil	Remove blockage.
	Low refrigerant charge	Add refrigerant
Unit operates long or continuously	Low-pressure control erratic in action	Replace control switch.
	Low indoor airflow	Clean filters.
	No indoor airflow	Check for broken fan belt Replace belts Check indoor fan circuit breaker (IFCB) If IFCB is tripped, reset.
	Low refrigerant charge	Add refrigerant
System Noises	Control contacts fused	Replace control.
	Air in system	Purge
	Partially plugged or plugged expansion valve or filter drier	Clean or replace.
	Defective insulation	Replace or repair.
	Service load	Keep doors and windows closed.
	Inefficient compressor	Check valves, replace if necessary.
	Piping vibration	Support piping as required. Check for loose pipe connectors
Compressor loses oil	Expansion valve hissing	Add refrigerant. Check for plugged liquid line filter drier.
	Compressor noisy	Check valve plates for valve noise. Replace compressor (worn bearings) Check for loose compressor holddown bolts.
	Leak in system	Repair leak.
Hot liquid line	Mechanical damage (blown piston or broken disch valve)	Repair damage or replace compressor.
	Oil trapped in line	Check piping for oil traps.
Frosted liquid line	Crankcase heaters not energized during shutdown	Replace heaters, check wiring and crankcase heater relay contacts.
	Shortage of refrigerant due to leak	Repair leak and recharge.
Compressor will not unload	Shutoff valve partially closed or restricted	Open valve or remove restriction.
	Restricted filter drier	Remove restriction or replace filter drier.
Compressor will not load	Burned out coil	Replace coil
	Defective capacity control valve	Replace valve.
	Miswired solenoid	Rewire correctly
	Weak, broken or wrong valve body spring	Replace spring
Compressor will not load	Miswired solenoid	Rewire correctly.
	Defective capacity control valve	Replace valve.
	Plugged strainer (high side)	Clean or replace strainer.
	Stuck or damaged unloader piston or piston ring(s)	Clean or replace the necessary parts

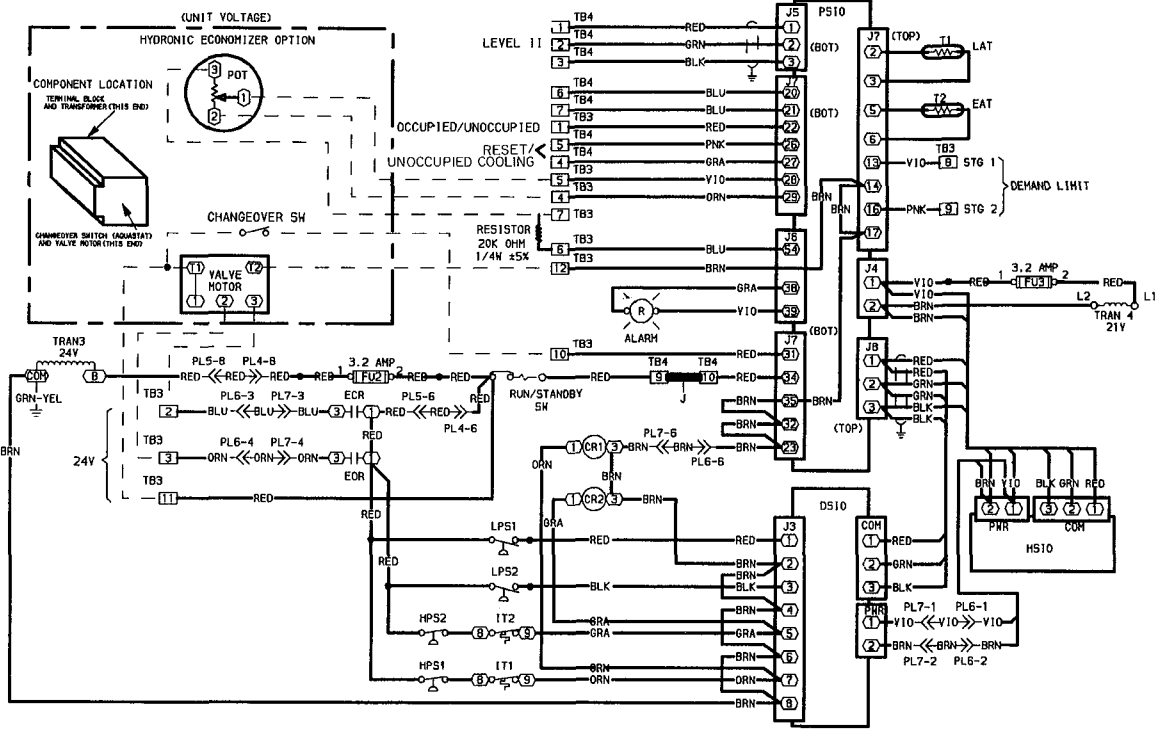
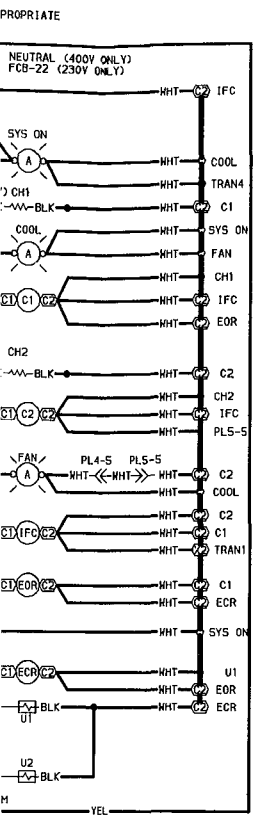

MODEL NO.	VOLTS	CIRCUIT BREAKER (COMP1) MFG. PART NO.		MUST TRIP AMPS	CIRCUIT BREAKER (COMP2) MFG. PART NO.		MUST TRIP AMPS	FAN CIRCUIT BREAKER MFG. PART NO.		MUST TRIP AMPS
		HEINEMANN	AIRPAX		HEINEMANN	AIRPAX		HEINEMANN	AIRPAX	
50BJP024500	208/230	47-100-6	209-3-2599-306	50	47-100-6	209-3-2599-306	50	CF3-Z33-B	219-3-2600-416	21
50BJP024600	460	CF3-Z33-19	219-3-2600-419	22	CF3-Z33-19	219-3-2600-419	22	CF3-Z33-17	219-3-2600-427	18
50BJP024100	575	CF3-Z33-60	219-3-2600-450	18	CF3-Z33-60	219-3-2600-450	18	CF3-Z33-B	219-3-2600-416	21
50BJP024800	230-3-50	47-100-10	209-3-2599-310	37	47-100-10	209-3-2599-310	37	47-100-28	209-3-2599-328	19
50BJP024900	400-3-50	CF3-Z33-19	219-3-2600-419	22	CF3-Z33-19	219-3-2600-419	22	CF3-Z33-17	219-3-2600-427	18
50BKP024500	208/230	47-100-7	209-3-2599-307	62	47-100-7	209-3-2599-307	62	CF3-Z33-B	219-3-2600-416	21
50BKP024600	460	CF3-Z29-2	219-3-2600-400	28	CF3-Z29-2	219-3-2600-400	28	CF3-Z33-17	219-3-2600-427	18
50BKP024100	575	CF3-Z33-19	219-3-2600-419	22	CF3-Z33-19	219-3-2600-419	22	CF3-Z33-B	219-3-2600-416	21
50BKP024800	230-3-50	47-100-15	209-3-2599-315	46	47-100-15	209-3-2599-315	46	47-100-28	209-3-2599-328	19
50BKP024900	400-3-50	CF3-Z29-2	219-3-2600-400	28	CF3-Z29-2	219-3-2600-400	28	CF3-Z33-17	219-3-2600-427	18

- NOTES:
- COMPRESSORS AND FAN MOTORS ARE THERMALLY PROTECTED... THREE PHASE MOTORS PROTECTED AGAINST PRIMARY SINGLE PHASING CONDITIONS.
 - IF ANY OF THE ORIGINAL WIRE FURNISHED MUST BE REPLACED IT MUST BE REPLACED WITH TYPE 90°C (OR ITS EQUIVALENT)
 - THE CB AND FCB MUST TRIP AMPS ARE EQUAL TO OR LESS THAN 140% FLA
 - ON TRANSFORMER-1 YEL WIRE IS CONNECTED TO TERMINAL H4 FOR 460V AND TO TERMINAL H2 FOR 575 & 208V. IF 230V SUPPLY IS USED TRANSFORMER MUST BE RECONNECTED. REMOVE YEL WIRE FROM TERMINAL H2 AND CONNECT TO TERMINAL H3.
 - ON 575V BLK & YEL WIRES CONNECT FROM TRAN-1 TO CB1

Schematic, Models 50BJ, BK024

POWER SCHEMATIC
208/230, 460, 575-3-60, 400-3-50

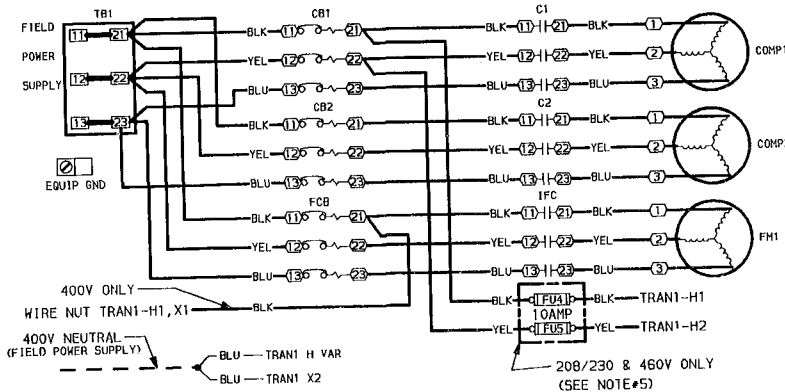

POWER SCHEMATIC
230-3-50

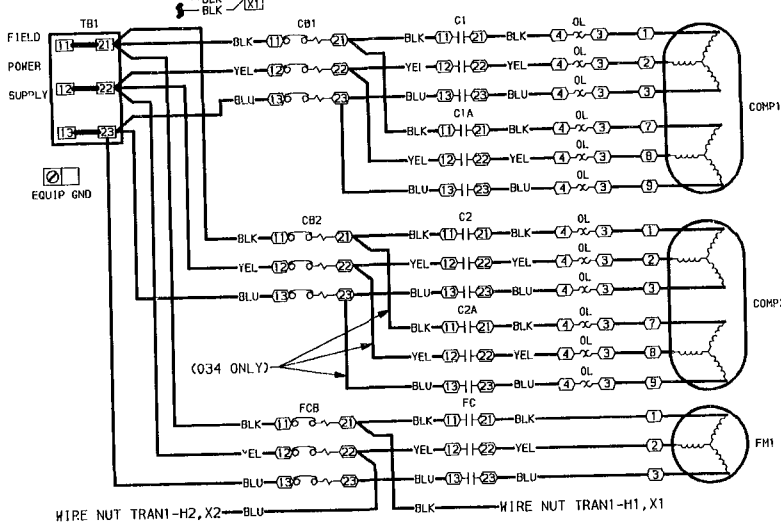

CONTROL SCHEMATIC

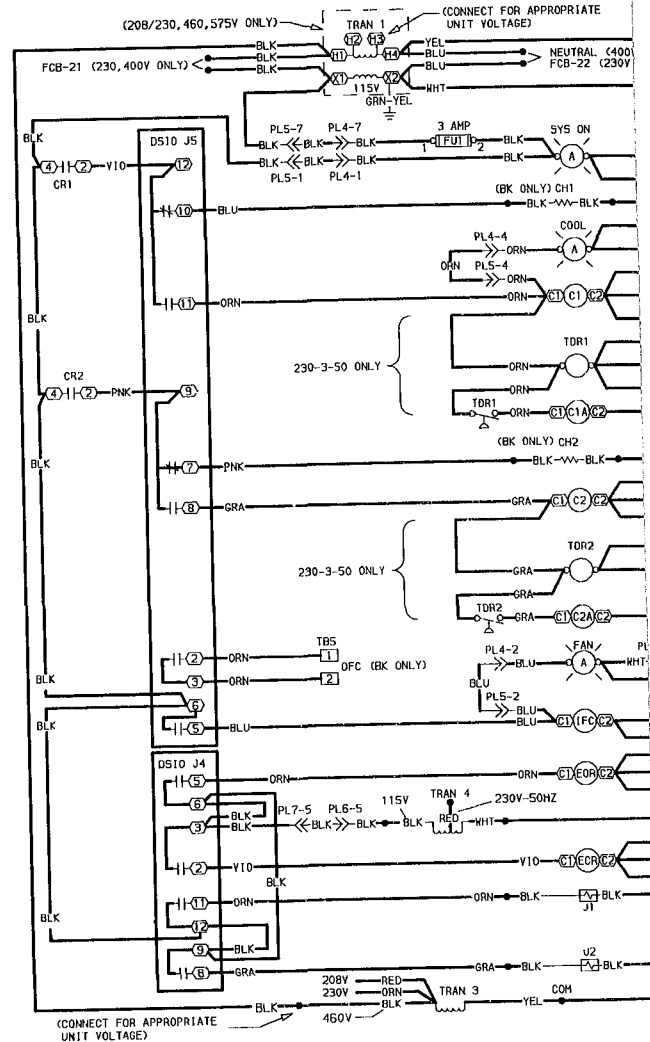

NOTES:

1. COMPRESSORS AND FAN MOTORS ARE THERMALLY PROTECTED AGAINST PRIMARY SINGLE PHASING.
2. IF ANY OF THE ORIGINAL WIRE FURNISHED MUST BE REPLACED WITH TYPE 90°C (OR ITS EQUIVALENT).
3. THE CB AND FCB MUST TRIP AMPS ARE EQUAL TO OR 140% FLA.
4. ON TRANSFORMER YEL WIRE IS CONNECTED TO TERMINAL H2 FOR 575 & 208V. IF 230V SUP TRANSFORMER MUST BE RECONNECTED REMOVE YEL W1 H2 AND CONNECT TO TERMINAL H3.
5. ON 575V BLK & YEL WIRES CONNECT FROM TRAN1 TO

Fig. 12 — Power and Control

CONTROL SCHEMATIC

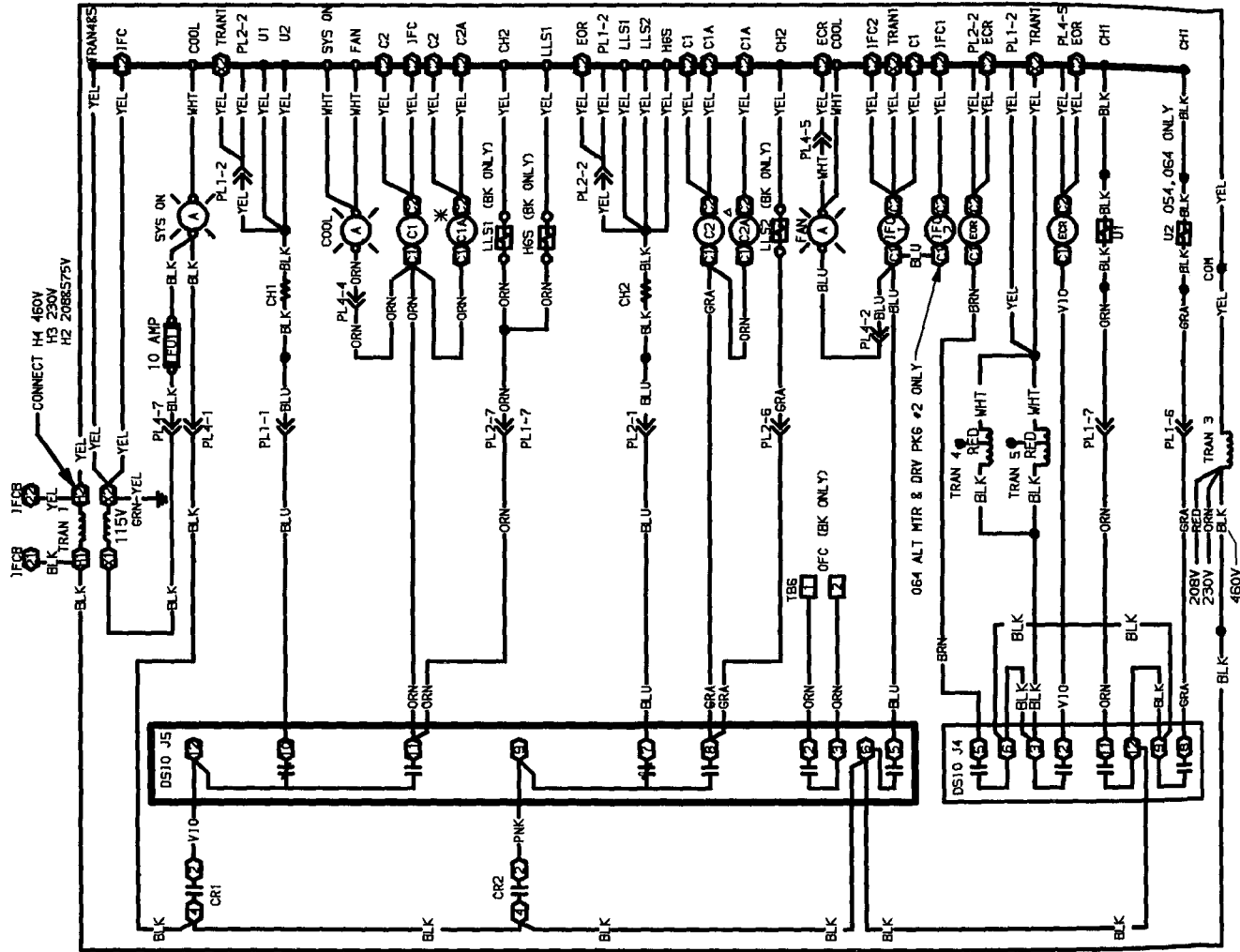

* BK054 208/230
BJ, BK064 208/230

4 BJ, BK064 208/230

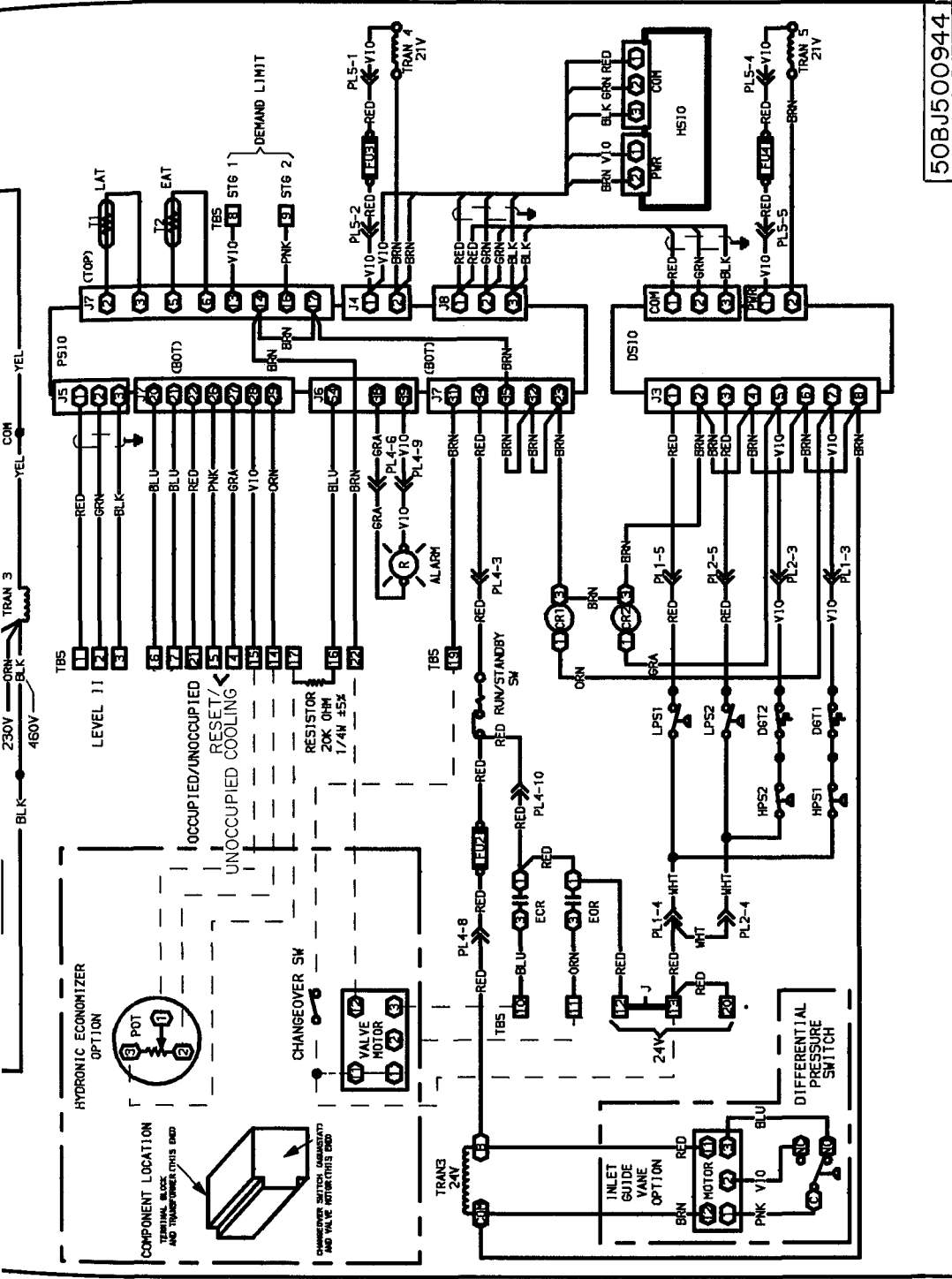
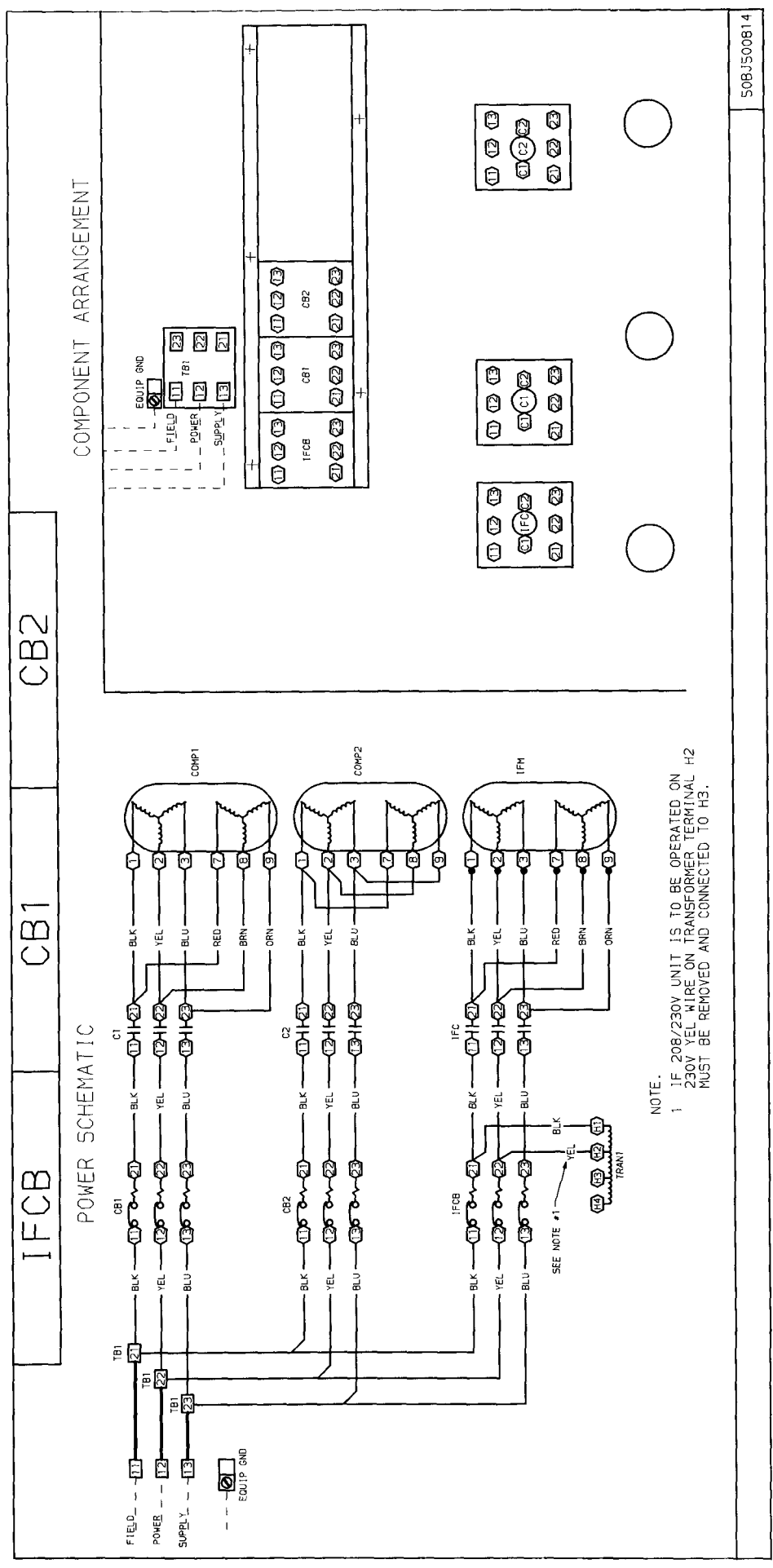











Fig. 13 — Control Wiring Schematic, Models 50BJ, BK044-064



50BJ500814

Fig. 15 -- Power Wiring Schematic, Model 50BJ054, 208/230 volt

LEGEND FOR FIG. 11 - 17

A	— Amber	POT.	— Potentiometer
C	— Compressor Contactor	PL	— Plug
CB	— Circuit Breaker	PR1	— Primary
CH	— Crankcase Heater	PSIO	— Processor Module
CLG	— Cooling	PWR	— Power
COM	— Common	R	— Red
COMP	— Compressor	SEC	— Secondary
CR	— Control Relay	SW	— Switch
DGT	— Discharge Gas Thermostat	SYS ON	— System On
DSIO	— Relay Module	TDR	— Time Delay Relay
ECR	— Economizer Close Relay	TB	— Terminal Block
EOR	— Economizer Open Relay	TRAN	— Transformer
EAT.	— Entering Air Temperature Sensor	U	— Unloader
FCB	— Fan Circuit Breaker		Terminal (Marked)
FM	— Fan Motor		Terminal (Marked)
FU	— Fuse		Terminal Block
GND	— Ground		Splice
HGS	— Hot Gas Solenoid		Splice (Marked)
HPS	— High-Pressure Switch		Factory Wiring
HSIO	— Local Interface Device		Field Wiring
IFC	— Indoor Fan Contactor		Accessory or Optional Wiring
IFCB	— Indoor Fan Circuit Breaker		Common Potential Only Does not represent actual wire.
IFM	— Indoor Fan Motor		
IT	— Internal Thermostat		
L	— Light		
LAT	— Leaving Air Temperature Sensor		
LLS	— Liquid Line Solenoid		
LPS	— Low-Pressure Switch		
OFC	— Outdoor Fan Contactor		
OFR	— Outdoor Fan Relay		
OL	— Overload		

Copyright 1990 Carrier Corporation

Manufacturer reserves the right to discontinue, or change at any time, specifications or designs without notice and without incurring obligations.

Book 1 PC 111 Catalog No 565-149 Printed in U.S.A Form 50BJ,BK-6SI Pg 33 9-90 Replaces: New
Tab 2a