



Installation, Start-Up, and Wiring Instructions

GENERAL

Carrier Temp System — The Carrier Temp System usually consists of more than one thermostat and can be expanded to meet whatever number of single zone systems are required.

The Temp System thermostat maintains proper temperatures by controlling the amount of heated or cooled air supplied to the area it is installed in or the area it controls (if using a Remote Room Sensor).

Each thermostat is responsible for controlling the temperature conditions in its space. Each thermostat will maintain its own independent occupied/unoccupied time schedule and heating/cooling set points. This allows the user to program the Temp System thermostat so that it will maintain different temperature ranges at different times.

Temp System Components — The Carrier Temp System consists of one or more thermostats that communicate by way of a communication bus. Each thermostat controls a relay pack which, in turn controls the HVAC unit. See Fig. 1.

Each thermostat can be connected to others to provide communication between thermostats. Only one thermostat per system can have a timeclock that will broadcast time to the rest of the system. See Fig. 2.

TEMP SYSTEM THERMOSTAT — The MST-01ES (with timeclock) and MS-01ES (without timeclock) Temp System Thermostats (see Fig. 3) have the following features:

- controls temperature to user defined set points
- eliminates external timeclocks, manual override timer, night low limit thermostat, battery backup, or unit time guard
- operates with 3 system switches for supply-air fan and the unit heating and cooling stages.

RELAY PACK — The relay pack (see Fig. 4) has the following features:

- serves as interface between thermostat, HVAC unit, and any external sensors
- powered by 24 VAC/10 VA, supplies thermostat with 10 VDC.

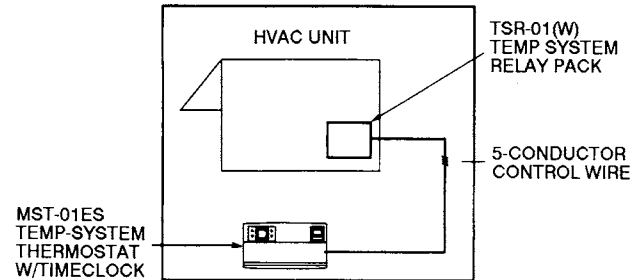

Fig. 1 — Carrier Temp System Components

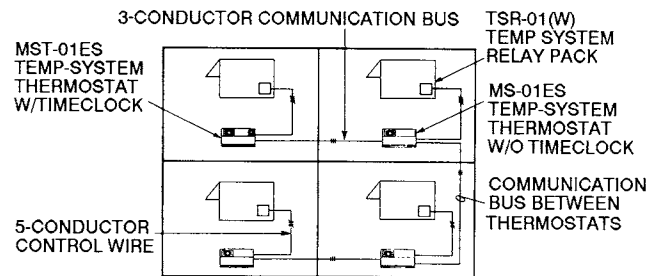

Fig. 2 — Temp System Communication

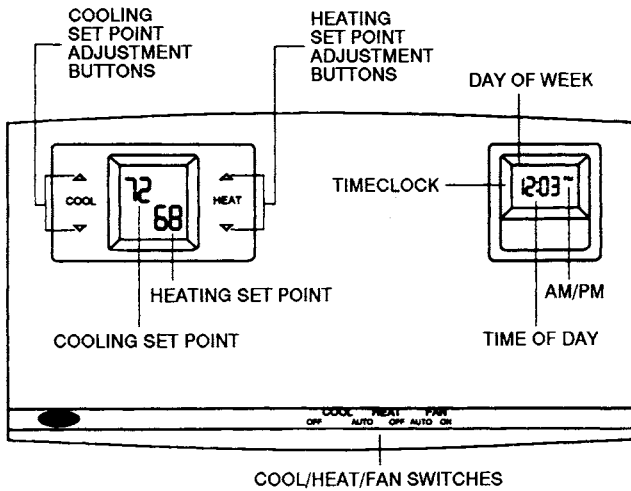

Fig. 3 – Temp System Thermostat (MST-01ES Shown)

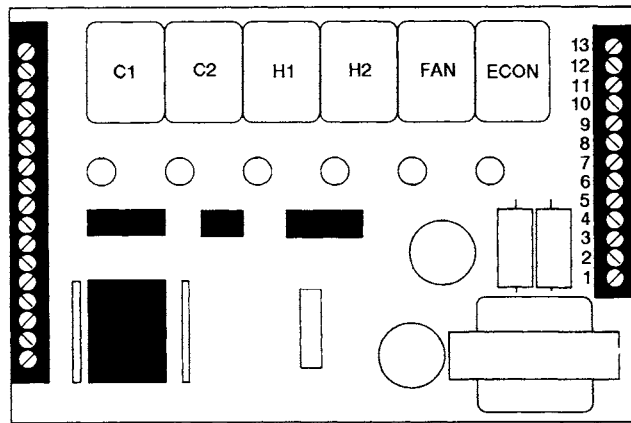

Fig. 4 – Temp System Relay Pack (TSR-01W Shown)

INSTALLATION

Wiring Requirements — The wiring requirements for the Temp System are:

THERMOSTAT TO THERMOSTAT COMMUNICATION BUS — Use 18 or 20 gage, 3-conductor, shielded, stranded wire, color coded (RED, BLACK, GREEN), plenum rated if required, long enough to run from thermostat to thermostat in daisy-chain configuration.

THERMOSTAT TO RELAY PACK — Use 18 or 20 gage, 5-conductor, shielded, stranded wire, color coded (RED, WHITE, BLUE, YELLOW, GREEN), plenum rated if required, long enough to run from thermostat to relay pack.

RELAY PACK TO HVAC UNIT — Use 6, 7, or 8 conductor wire, depending on HVAC unit. Sized to run from relay pack to the wiring terminals of the HVAC unit.

NOTE: Do not run the thermostat communication bus and the control wire in the same conduit for more than 5 ft. Never run wires near any cable carrying AC voltage. For further wiring information, consult the Carrier Temp System distributor.

Power required to each relay pack is 24 VAC/ 10 VA. Typical wiring is 18 gage thermostat wire (standard or plenum cable). Power to the relay pack may be wired to the HVAC unit transformer if of sufficient VA capacity, otherwise a dedicated transformer is recommended. The maximum load of a relay contact is 24 VAC, 1 amp. A short in the field wiring or HVAC unit will cause non-warranty damage to the relay board. Test before attaching to relay pack.

Call the local Carrier representative if more information is needed about wiring the Temp System.

Thermostat Installation — Begin the thermostat installation by determining where the thermostat will be located. In most cases, this will be pre-determined by the building plans.

The thermostat should be located on an interior wall, about 5 ft from the ground. The thermostat should be located away from direct sunlight, drafts, or interior heat sources which may influence temperature readings.

The thermostat may also be mounted in a remote location with the use of an optional remote room sensor. Refer to the thermostat Application Instructions for more information on thermostat installation.

Relay Pack Installation — The relay pack should be installed in the HVAC unit control box if climate or space conditions allow. If the temperature range of 32 to 150 F may be exceeded (at a relative non-condensing humidity of less than 99%), then the relay pack should be installed at another location such as a plenum space or utility room.

Wiring Connections

WIRE RELAY PACK TO THERMOSTAT — Wire each thermostat to its respective relay pack as shown in Fig. 5. Wiring connections should be made at the wiring connector board of the thermostat.

⚠ WARNING

Electric shock can cause injury or death. Ensure power to the HVAC unit has been disconnected before wiring.

NOTE: For more information about wiring the thermostat to the relay pack, refer to the TSR-01 or TSR-01W installation instructions included with each relay pack.

WIRE RELAY PACK TO HVAC UNIT — Wire the relay pack to the HVAC unit as shown in Fig. 6 or 7. Refer to Fig. 6 for TSR-01 relay packs. Refer to Fig. 7 for TSR-01W relay packs. All wiring and the relay pack should be kept a minimum of 12 in. away from any cables carrying AC current. For more information refer to the installation instructions included with each relay pack.

WIRE THERMOSTAT TO COMMUNICATION BUS — The thermostat is connected to the communication bus through the thermostat wiring connection block. Connect the BLACK, RED, and GREEN wires from the communication bus to the thermostat wiring connection block. See Fig. 5. To connect other devices to the communication bus, refer to the application manual for that device.

Provide Power To Relay Pack — After the wiring has been completed, provide power to the relay pack. Once power has been provided to the relay pack, the relay pack will provide power to the thermostat. The heating or cooling set points will appear on the thermostat display screen. The thermostat is now ready to be programmed. If the display is blank or blinking, recheck the wiring connections between the thermostat and relay pack.

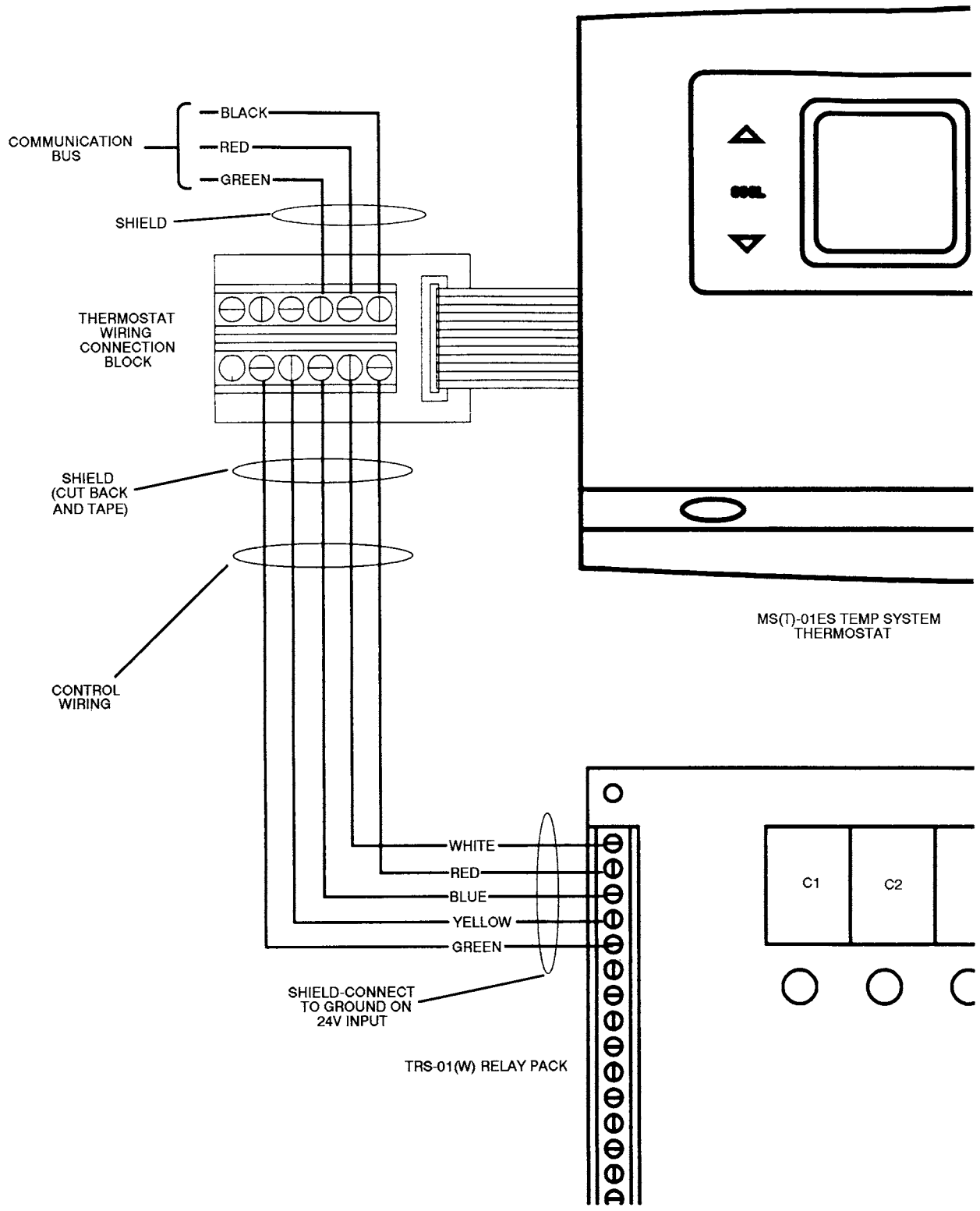

Fig. 5 – Thermostat to Relay Pack Wiring

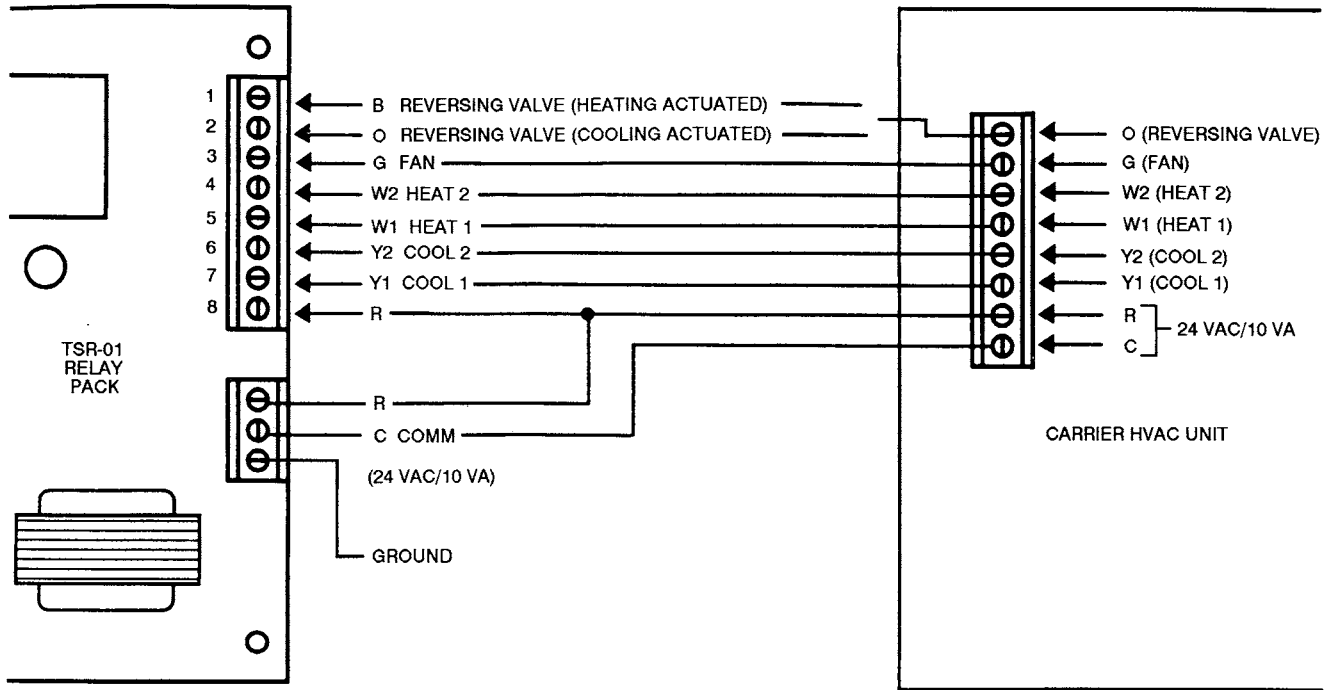

Fig. 6 – TSR-01 Relay Pack Wiring

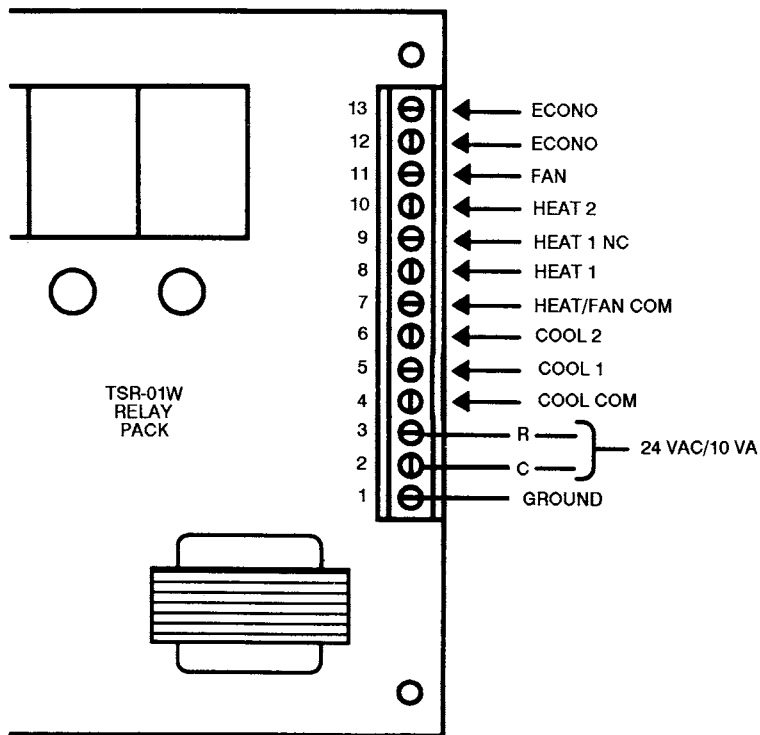

Fig. 7 – TSR-01W Relay Pack Wiring

START-UP

Prior to being shipped from the factory, the thermostat is preset to operate as installed. If the Temp System is being connected to a computer for communication, interfaced with another Carrier Temp system, or a new occupied/unoccupied schedule is to be configured, then a few adjustments will need to be made.

Device Address — The device address gives the thermostat a unique identification on the communication bus. Remove the cover of the thermostat to expose the rotary switch. See Fig. 8. Turn the rotary switch to position 1. Use the left set point buttons to adjust the display to the desired address. All thermostats leave the factory with an address of 1. Acceptable addresses range from 1 to 64. After selecting an address, return the rotary switch to the 0 position. Replace the cover if configuration is complete.

Timeclock Operation — If the thermostat has a timeclock, the clock must be set. To set the time, remove the thermostat cover. After the cover has been removed, follow the instructions on the timeclock. See Fig. 9.

NOTE: Components designated with a W or T are provided with a timeclock.

W973 Economizer Control — If using a TSR-01W, the W973 Economizer Control (F31) option needs to be configured for the thermostat. If using a W973 economizer controller, set option F31 to ON.

Programmable Setback Schedule — The programmable setback schedule (occupied/unoccupied) of the thermostat allows the user to determine when the thermostat maintains comfort set points and when it switches to the setback set points.

To use the programmable setback feature, the Temp System must have access to the time of day. This is typically provided by the timeclock on the thermostat, or by having the time set through communication bus by another thermostat that has a timeclock.

Each Temp System thermostat may be individually programmed for each day of the week. Each day may be programmed for up to 2 ON/OFF times. During an ON time, the thermostat maintains comfort set points and displays them on the thermostat. During an OFF time, the thermostat displays the word SETBACK and the setback set points.

NOTE: The thermostat will not follow the programmed Setback Schedule unless the Local Setback Control option (rotary switch position F2) is set to ON.

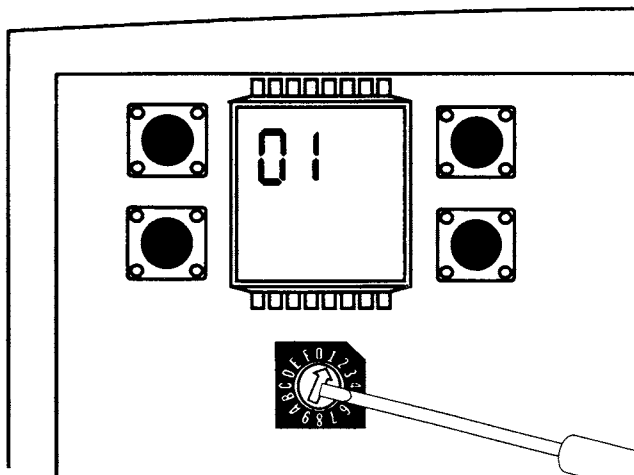

Fig. 8 — Thermostat Cover Removed

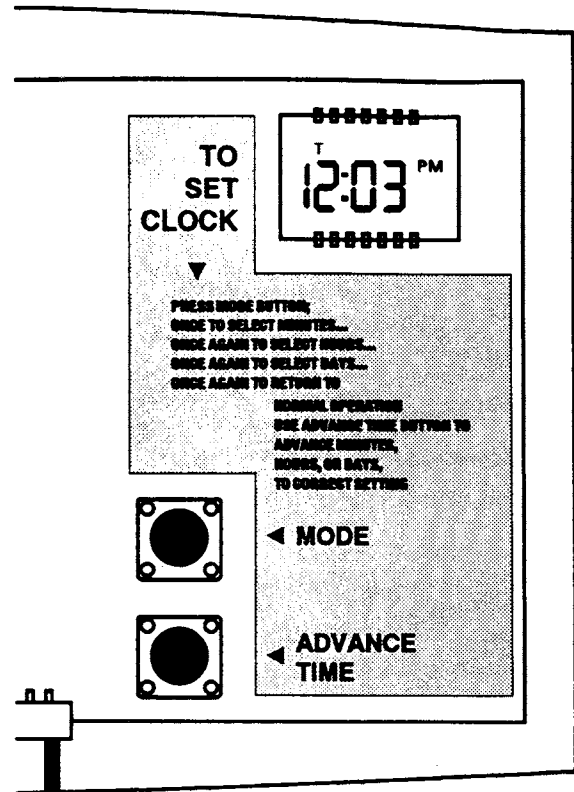

Fig. 9 — Timeclock Operation

Each Temp System thermostat leaves the factory programmed to operate in comfort continuously. To change from the factory program, appropriate ON/OFF times need to be programmed. To enter ON/OFF times, perform the following:

1. Starting with normal Temp System operating display, enter the program mode by pressing either both set point increase buttons or both set point decrease buttons at the same time. The setback configuration will be shown. If there has been no previous program, the default settings will be shown. See Fig. 10.
2. Select the day to be programmed. (1 = Monday, 2 = Tuesday, etc.). See Fig. 11.
3. Erase the current program for this day by pressing the Select Day and Select ON/OFF buttons at the same time. Two zeros and the word ON will be displayed. See Fig. 12.
4. Press the Select Hour button until the time for the beginning of the comfort period is displayed. See Fig. 13.
5. Press the Select ON/OFF button once. The word OFF should now be displayed. See Fig. 14.
6. Press the Select Hour button until the time for the start of the setback period is displayed. See Fig. 15.
7. If a second comfort period for the same day is desired, press the Select ON/OFF button once. The word ON will be displayed. Repeat Steps 4 to 6 to set the second comfort period.
8. Press the Select Day button to change the display to the next day to be programmed. Configure the comfort periods for the remaining days.

NOTE: If the selected day is to have the same comfort schedule as the previous day, the copy previous day button can be used to duplicate the previous comfort schedule. See Fig. 16.

- To exit the program mode, press both set point increase buttons or both set point decrease buttons at the same time.

NOTE: If a button is not pressed for 30 seconds while in program mode, the thermostat will return to the set point display.

To Check System Operation — The Temp System thermostat should select a system mode after power up. To check operation of the Temp System thermostat, perform the following steps. If the Temp System thermostat does not operate, contact the Carrier distributor.

- The zone must be 1.5° F or more from set point.
- The thermostat system switches (FAN, COOL, and HEAT) must be set to AUTO or ON to operate.
- Ensure the thermostat heating and cooling Time Guard has had time to expire. If the Time Guard Between Modes option (rotary switch position F32) has been configured to ON, the system will not operate until Time Guard has expired. Time Guard delay occurs after power up, reset, or system mode has been released. Length of the Time Guard is (2.6 seconds x monitor thermostat device address) + 5 minutes.

If the Time Guard Between Modes option is configured OFF, the length of the Time Guard is approximately 1.5 minutes.

For Temp Systems, the Time Guard Between Modes option is always ON.

The Time Guard Override option may be used to override the Time Guard to 30 seconds for one cycle. To activate the override, turn the thermostat rotary switch to position F. Use the right set point buttons to toggle the option to ON. Return the rotary switch to the 0 position.

- Set the Alternate Information function of the thermostat to ON. Turn the rotary switch to position F. Use the left set point buttons to toggle the display to 3. Use the right set point buttons to toggle the option ON. Return the rotary switch to the 0 position. Check the monitor thermostat display for a flashing HEAT or COOL annunciator. A flashing annunciator indicates that the supply-air temperature has exceeded the configured limits.

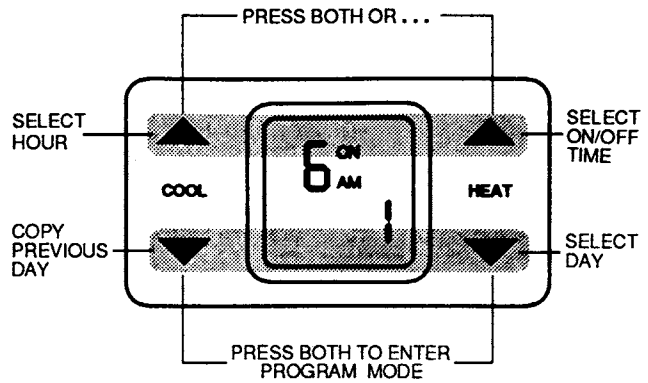

Fig. 10 — Enter Program Mode

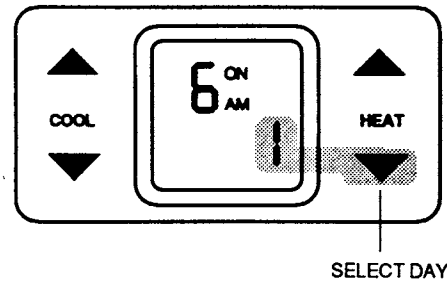

Fig. 11 — Select Day

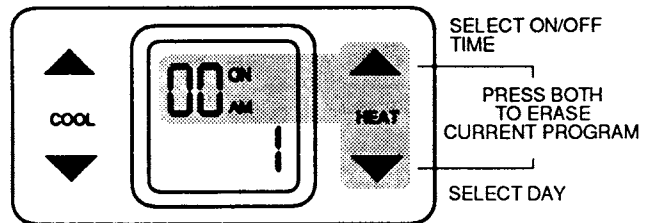

Fig. 12 — Erase Current Day Schedule

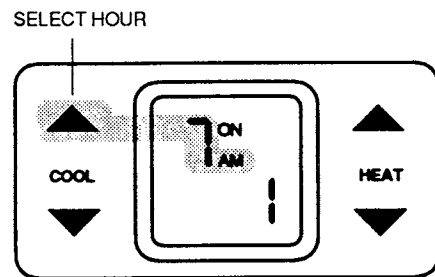

Fig. 13 — Select Hour For ON Time

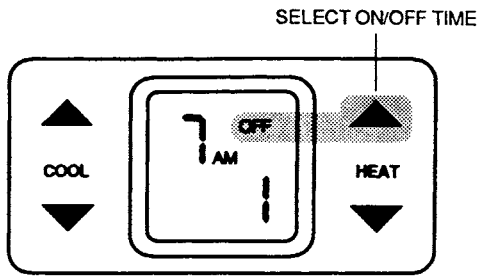

Fig. 14 – Select OFF Time

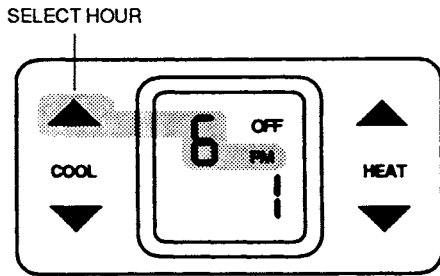

Fig. 15 – Select Hour For OFF Time

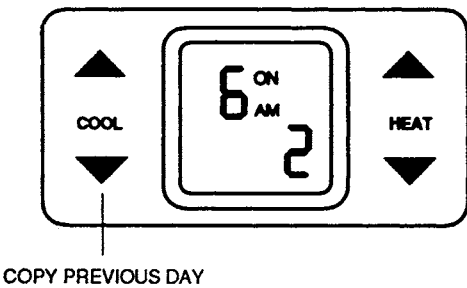

Fig. 16 – Copy Previous Day

5. Ensure the monitor thermostat is free of possible HF (Hardware Failure) or SF (Storage Failure) errors that can lock out the ability of the thermostat to energize a mode. HF and SF errors will be displayed on the thermostat if the Error Code Display option is configured to ON. Turn the rotary switch to position F. Use the left set point buttons to toggle the display to 11. Use the right set point buttons to toggle the option ON. Return the rotary switch to the 0 position.
6. Check the configuration of the thermostat System Heating Mode Lockout, Heating Lockout Temperature Set Point, and Cooling Lockout Temperature Set Point options. Based on the outside-air temperature, the thermostat can lock out either system cooling or heating modes. Refer to the thermostat application data for information on setting the configurable options of the thermostat.

TEMP SYSTEM MONITOR THERMOSTAT CONFIGURATION TABLE

ROTARY SWITCH SETTING	CONFIGURATION OPTION	FACTORY SETTING	DEVICE LOCATIONS					
1	Device Address	1						
2	Setback Override Time Limit	60						
3	Setback Set Points	85/60						
4	Comfort Set Point Limiting	80/66						
5	N/A	-						
6	Zone Temperature Sensor Calibration	-						
7	Supply-Air Temp. Sensor Calibration	-						
8	Airflow Sensor Error Correction	-						
9	Redline/Remote Schedule Group Numbers	0						
A	Smart Start Time Limit	0						
B	N/A	-						
C	Cooling Lockout Temperature Set Point	0						
C	Heating Lockout Temperature Set Point	0						
D	N/A	-						
E	Duct Temperature Heating Limits	05						
F1	Time Guard Override	OFF						
F2	Local Setback Control	ON						
F3	Alternate Information	OFF						
F4	N/A	-						
F5	N/A	-						
F6	Smart Stop	OFF						
F7	Smart Start	OFF						
F8	Celsius Temperature Display	OFF						
F9	N/A	-						
F10	N/A	-						
F11	Error Code Display	ON						
F12	N/A	-						
F13	Local Setback Override Lock	OFF						
F14	Meter Setback Override	OFF						
F15	Meter HVAC	OFF						
F16	N/A	-						
F17	2400 Baud Rate	ON						
F18	DX Coil Temperature Sensor	OFF						
F19	Local Outside Air Temp. Sensor	OFF						
F20	Local Humidity Sensor	OFF						
F21	High/Low Temperature Limit	ON						
F22	Secondary High/Low Temperature Limit	OFF						
F23	Heat Pump System	OFF						
F24	Fan On Cooling Only	OFF						
F25	Temperature Trend Staging	ON						
F26	System Heating Mode Lockout	OFF						
F27	N/A	-						
F28	Setback Relay	OFF						
F29	N/A	-						
F30	N/A	-						
F31	W973 Economizer Control	OFF						
F32	Time Guard Between Modes	OFF						
Com. Only	Comfort Trend Demand Set Point	0						
Com. Only	Comfort Trend Time Limit	0						
Com. Only	Device Security Code	0						
Com. Only	DX Coil Temp. Sensor Calibration	-						
Com. Only	Local Humidity Sensor Calibration	-						
Com. Only	Local Outside Air Temp. Sensor Cal.	-						
Com. Only	Rotary Switch Lock	OFF						
Com. Only	System Airflow Set Point	0						
Com. Only	System Cooling Mode Set Point	0						
Com. Only	System Heating Mode Set Point	0						
Com. Only	System Mode Re-Select	30						
Com. Only	Equipment Usage Meter	0						

N/A — Not used on Temp System monitor thermostat.

Copyright 1994 Carrier Corporation