

# INSTRUCTIONS



**Carrier**

A United Technologies Company

**\*99TA526340\***

Instruction Sheet Number: **99TA526340**

\*99TA526340\* (for RCD use only)

Description: EXTERNAL PUMP CONTROL KIT

Author: Steve Bayes

Date: June 28, 2006

Part Number: 30XA660005

## SAFETY CONSIDERATIONS

Installing, starting up, and servicing air-conditioning equipment can be hazardous due to system pressures, electrical components and equipment location.

Only trained, qualified installers and service technicians should install, start up, and service this equipment.

When working on air-conditioning equipment, observe precautions in the literature, on tags, stickers, and labels attached to the equipment.

Follow all safety codes. Wear safety glasses and work gloves. Use care in handling equipment.

### Warning

Be sure power to equipment is shut off before performing maintenance or service to avoid electrocution. Lock out and safety-tag all disconnects. There may be more than one disconnect.

## GENERAL

This Kit provides required components to integrate the external pump into the 30XA chiller control. As part of the chiller control, the pump will be commanded ON/OFF based on the chiller operation. The pump will also be monitored through the chiller control for its status. And the corresponding alarms will be reported if the pump does not operate normally.

One Kit package is required for 30XA080-500 units

## INSTALLATION

Examine the package contents for correct part numbers. If any of the components are damaged, file a claim with the shipping company and notify a Carrier representative.

See Table 1 for package contents.

The following material is field supplied:

- 18 AWG wires for pump control wiring
- Wire terminals and wire ties

Table 1 - Contents of Kit 30XA660005

PART NUMBER	QUANTITY	DESCRIPTION	USAGE
32GB500432EE	1	Pump Board	Mount in control box
TYZ:TH70400864	1	Harness assembly	Wiring for pump board
HH83ZB001	1	24V circuit breaker (CB14)	Mount on display bracket in control box
A6X10004352	4	No. 8 screw	Mount pump board
A6X10004434	4	Board mounting standoff	Mount pump board (30XA080-120, 200V, 230V, 380V and 30XA140-500 units)
TYZ:TH70400852	1	Communication cable assembly	30XA080-120, 200V, 230V, 380V and 30XA140-500 units.
HY89TB010	5	Wire nut	Splice communication cable (30XA080-120, 460V, 575V units) and pump interlock wiring

## Install Pump Board and Control Wiring

### Warning

Shut off all power to the unit. Lock out and safety-tag all disconnects. Remove refrigerant charge from the circuits using an approved refrigerant recovery device before proceeding with this installation. Follow good piping practices. Severe personal injury could result.

1. Set the board address switch on the pump board per Fig. 2. Mount the pump board in the main control panel with the No. 8 screws (mounting standoffs required for 30XA080-120, 200V, 230V, 380V and 30XA140-500 all voltages). See Fig. 3, 4 for the board mounting place.
2. Mount the 24V circuit breaker(CB14) to the CB14 mounting hole on the display mounting bracket. See Fig. 3, 4 for the mounting hole location. The display mounting bracket can be easily removed by loosening the four mounting screws on the corners.
3. Connect the 24V power from TB10-X1(30XA080-120, 460V, 575V only) or TB11-X1(all other units) to CB14 with a red wire in the harness assembly TYZ:TH70400864 provided in the kit. Find a 2 pin plug marked J1-11,12 with a red wire and a brown in the harness assembly. Connect the plug to the pump board J1. On the other end, connect the red wire from the plug to CB14 and the brown wire to TB10-X2(30XA080-120, 460V, 575V only) or TB11-X2(all other units). Refer to the schematics as Fig. 1.
4. Connect between TB5-11, 15, 13 and pump board CH1, CH2 in J2 per Fig. 2 with harness assembly provided. Use the pins on the back of TB5. If only one pump available in the system (no backup pump), the wiring for pump board CH2 is not required.
5. For 30XA080-120, 200V, 230V, 380V and 30XA140-500 units, disconnect the 3 pin plug on MBB J9B (or EMM board J9A) for communication and plug it to the pump board J9. Use the additional communication cable assembly TYZ:TH70400852 provided in the kit to connect between pump board J9 and MBB J9B (or EMM board J9A when EMM board exists). The communication cable in the TYZ:TH70400864 harness will not be used. For 30XA080-120, 460V, and 575V units, connect the 3 pin plug of the communication cable in the TYZ:TH70400864 harness to the pump board J9 and splice the other end of the cable to the communication network using the wire nuts provided in the kit. Be sure to splice the wires with same color together to ensure correct polarity.
6. Wire the coils of pump contactors to TB5-11, 15 and 13 per schematics shown in Fig. 2 with field supplied 18AWG wires and wire terminals. If only one pump available in the system (no backup pump), the wiring for PMP2 is not required.
7. Locate the main base board in the main control panel. Refer to Fig. 3, 4. Near CH18 (J5C) of the board, there are violet and pink wires tied up outside the wire duct terminated with wire nuts. These wires are for pump auxiliary contact wiring. Remove the wire nuts and connect the two wires to pump auxiliary contacts per Fig. 5 with field supplied wiring. If only one pump is available in the system (no backup pump), the wiring for PMP-2 is not required.

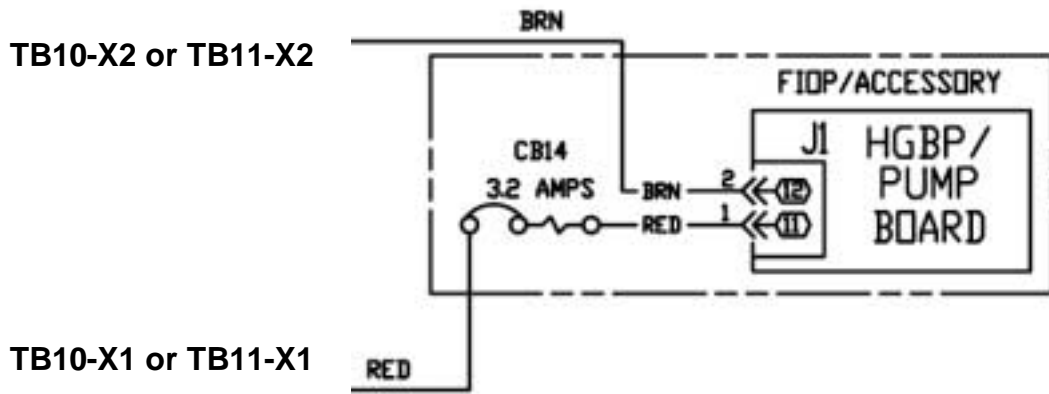

Fig. 1 – Pump Board 24V power wiring

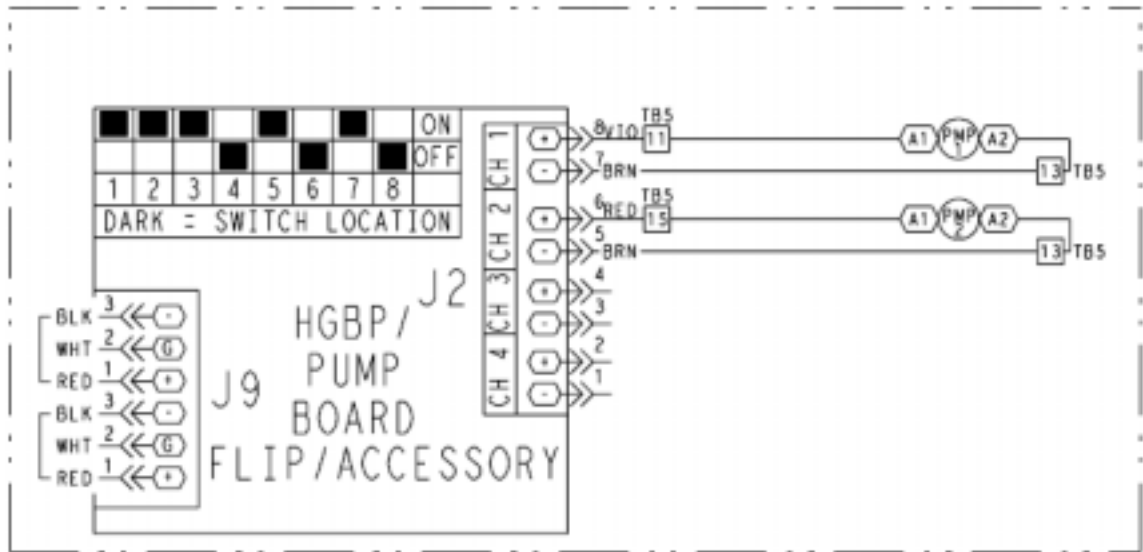

Fig. 2 – Pump Board Address Switch and Wiring for Pump Output

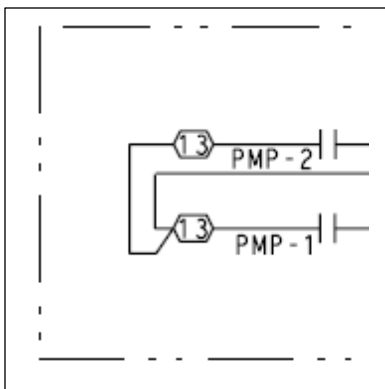

Fig. 5 – Pump Interlock Wiring on Main Base Board

Main Base Board

### Configure Unit for Pump Control –

The control must be configured for the pump control operation. Use the Navigator or Touch Pilot display to configure the system. To configure the system with Navigator, follow the steps below.







1. Set the Enable/Off/Remote switch to OFF position.
2. Press **ESCAPE** until the screen is blank and use the arrow key to select the Configuration mode LED.
3. Press **ENTER**, then use arrow key to select the sub-mode 'OPTN', then press Enter key.
4. Press the down arrow key until 'PUMP' is displayed.
5. Press **ENTER** key twice. The word 'PASS' and 'WORD' will flash.
6. Press 0 1 1 1 then **ENTER** key so that '0' flashes.
7. Use arrow keys to change value to one of the following configurations:

CONFIGURATION	DESCRIPTION
1	One pump only
2	Two pumps auto changeover
3	Pump 1 manual*
4	Pump 2 manual*

\* Used with dual pumps



8. Press the **ENTER** key.
9. Press the **ESCAPE** key until 'DISP' is displayed. Wait 10 seconds and cycle the control power using the On/Off switch. The chiller is now configured for pump control.

To configure the system with Touch Pilot display, follow the steps below.

1. Ensure the unit is in Local Off operating mode by looking at the left upper corner of the group display. If the unit is not in Local Off mode, push the start/stop button  to switch it to the Local Off mode.
2. Push the main menu button  on the bottom line of display, and then follow the path Config→USER to the USER table.
3. Scroll down the screen by pushing scroll down button  or page down button  until the Cooler Pumps Sequence shown on the screen. Push the Cooler Pumps Sequence bar on the screen, the point data menu will pop up.
4. Push modify button  in this point data menu. If the login menu comes up, log in with password of 3333, hit OK button  to confirm the input. The value of CCN variable cpumpseq will show up. Enter 1, 2, 3, or 4 per configuration table below and hit OK button  to confirm the input.

CONFIGURATION	DESCRIPTION
1	One pump only
2	Two pumps auto changeover
3	Pump 1 manual*
4	Pump 2 manual*

\* Used with dual pumps

5. Push the Home button  on the bottom line. A save confirmation menu will pop up. Hit OK button  to confirm the action.

This chiller is now configured for pump control.

**Test Pump Output**—Use the Navigator or Touch Pilot display, the instructions given in the Controls, Start-Up, Operation Service and Troubleshooting manual and the Service Test mode to verify proper operation of the pump output. Be sure to turn off the fuse or circuit breaker for the pump(s) and watch if the pump contactor(s) is being energized during the test. For Navigator, illuminate the Service Test LED, enter the TEST mode, enable the test request, 'T.REQ' and test outputs 'PMP.1', 'PMP.2'. For Touch Pilot display, from main menu, follow the Status→QCK\_TST1,

enable the Quick Test, and test outputs 'Water Exchanger Pump 1', 'Water Exchanger Pump 2'. Once the outputs have been tested, the installation is complete. Return the Enable/Off/Remote contact switch to the desired position.