



Installation Instructions

Part No: 00EFN900000100A

SAFETY CONSIDERATIONS

Installing, starting up, and servicing air-conditioning equipment can be hazardous due to system pressures, electrical components and equipment location.

Only trained, qualified installers and service technicians should install, start up, and service this equipment.

When working on air-conditioning equipment, observe precautions in the literature, on tags, stickers, and labels attached to the equipment.

Follow all safety codes. Wear safety glasses and work gloves. Use care in handling equipment.

⚠ WARNING

Be sure power to equipment is shut off before performing maintenance or service to avoid electrocution. Lock out and safety-tag all disconnects. There may be more than one disconnect.

GENERAL

This control accessory reduces 30RB chiller capacities below the standard lowest capacity step. This capacity reduction provides more precise control of leaving fluid temperature during light load conditions.

The solenoid valve limits the amount of gas that can be bypassed from the condenser without impacting oil return.

One accessory package is required for 30RB060-190 units and for each module of duplex units 30RB315-390. Two accessory packages are required for 30RB210-300 units to accommodate connections for all three refrigerant circuits. See Table 1 for modular unit combinations.

Table 1 — Modular Unit Combinations

UNIT SIZE	MODULE A	MODULE B
30RBA315	30RBA160	30RBA160
30RBA330	30RBA170	30RBA160
30RBA345	30RBA170	30RBA170
30RBA360	30RBA190	30RBA170
30RBA390	30RBA190	30RBA190

NOTE: An "A" in the model number indicates the design series.

INSTALLATION

Examine the package contents for correct part numbers. If any of the components are damaged, file a claim with the shipping company and notify a Carrier representative.

See Table 2 for package contents. See Fig. 1 for dimensional drawings of tubes included in the kit.

The following material is field supplied:

- 1/2 in. OD copper tubing
- standard 1/2 in. copper tube elbows and couplings as required

Install the Solenoid Valve

⚠ WARNING

Shut off all power to the unit. Lock out and safety-tag all disconnects. Remove refrigerant charge from the circuits using an approved refrigerant recovery device before proceeding with this installation. Follow good piping practices. Severe personal injury could result.

1. Shut off power to the unit.
2. Remove refrigerant charge from the unit.
3. Locate the factory-supplied stub on the discharge line for each circuit. Locate the 1/2 in. NPT pipe plugs at the blank end of the cooler for 30RB110 circuit B and for both circuits A and B on 30RB060-300 units. See Fig. 2.
4. Remove the 1/2 in. NPT pipe plugs from the blank end of the cooler. Use an appropriate thread sealing compound and install one 1 in. - 14 ORS adapter for each circuit. Lightly lubricate each O-ring and attach a 5/8 in. ORS tube assembly to each adapter. This nut should be torqued to 30 ft-lb (40 N-m). For 30RB110 circuit A size only, use a tubing cutter to cut off the end of the stub tube. See Fig. 3.
5. Assemble the hot gas bypass line in the following order:
 - Remove the discharge stub tube and braze the correct beaded tube in place.
 - Braze the ball valve to the beaded tube.
 - Braze the solenoid valve into the line.
 - Using field-supplied tubing, connect the solenoid valve to the low side connection, either the cooler or the liquid line.
 - Clamp the 5/8-in. tube to the rail. See Fig. 4 and 5.

Use field-supplied 1/2 in. OD copper tubing and fittings (as required) to plumb from the solenoid valve outlet to either the adapter tube in the cooler or stub tube in the liquid line depending on unit size. Tube support brackets and 1/2 in. tubing clamps are provided with the kit. Install brackets to the bottom of the coil bases to support tubing.

IMPORTANT: The valve is direction specific and must have the arrow pointing toward the cooler. The solenoid valve will not properly seat if installed backwards.

6. Dehydrate and recharge each circuit.
7. Restore power to the unit.

NOTE: When piping is completed, leak test the assembly. Then evacuate, dehydrate, and recharge the circuit using approved refrigeration practices. Be sure to use the correct type and amount of refrigerant listed in the nameplate data and base unit documentation.

Table 2 — Contents of Accessory Kit

PART NUMBER	QUANTITY	DESCRIPTION	USAGE
00PPN50000600A	2	5/8 in. tube assembly with 90-degree bend and 1 in. — 14 ORS nut	Blank end of the cooler except in 30RB110 circuit A
00PPN50001000A	2	Solenoid valve with 1/2 in. ODF connections	All
00PSN500023900A	2	5/8 in. beaded tube with 1/2 in. swage (used with 1 1/8 in. discharge lines)	30RB060,070,110,120, circuit A and 30RB080-100 circuits A and B
00PSN500024000A	1	5/8 in. beaded tube with 1/2 in. swage	30RB060,070 circuit B
00PSN500024400A	2	5/8 in. beaded tube with 1/2 in. swage (used with 1 5/8 in. discharge lines)	30RB110,120 circuit B and 30RB130-390 all circuits
00PSN500023600A	4	Tube support bracket	30RB060-110, circuit A (1 required) 30RB120,130 (2 required) 30RB150 (3 required) 30RB160-390 (4 required)
00PPN50000302A	8	M6 screw	All, mount tube support brackets
00PPN50000401A	7	No. 10 screw	All, mount tube clamps
EP71BA181	2	1/2 in. ball valve	All, put in discharge line after solenoid valve so circuit can be isolated
30GX503492	2	1 in. — 14 ORS by 1/2 in. NPT adapter	All at blank end of cooler except 30RB110 circuit A
KA66AA050	5	1/2 in. tube clamp	30RB060-110 (1 required) 30RB120,130 (2 required) 30RB150 (3 required) 30RB160,170,190,315-390* (4 required) 30RB210-300* (5 required)
KA66AA062	2	5/8 in. tube clamp	All, one per circuit just before solenoid
SF703318	2	Cable assembly	All, one per circuit

*Requires two kits.

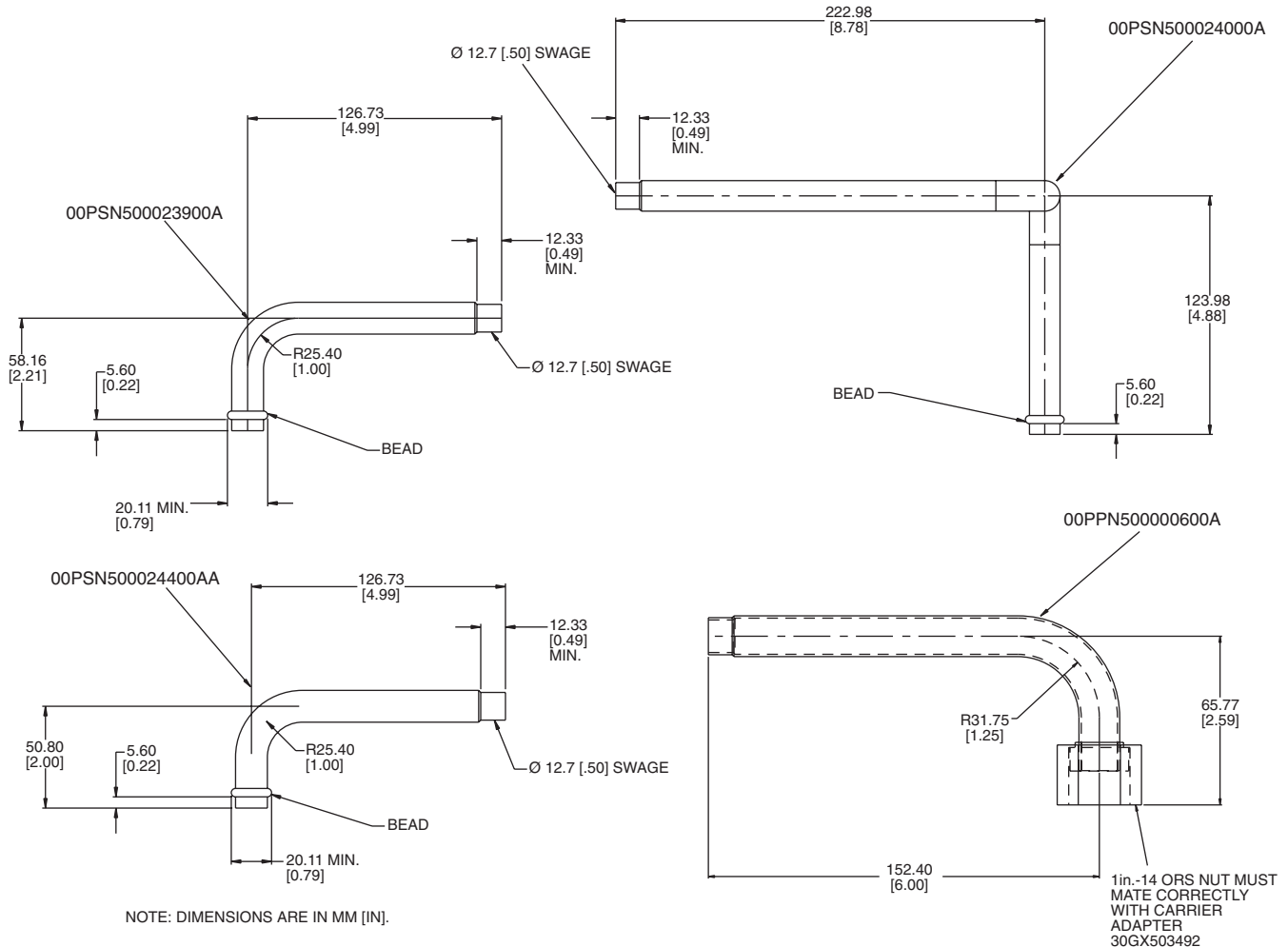

NOTE: Dimensions are in mm [in.].

Fig. 1 — Dimensions of Tubes Provided in Accessory Kit

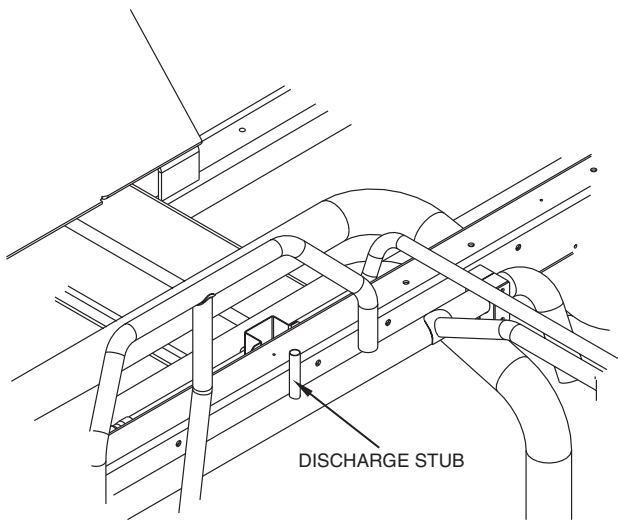

Fig. 2 — Typical Stub Tube View

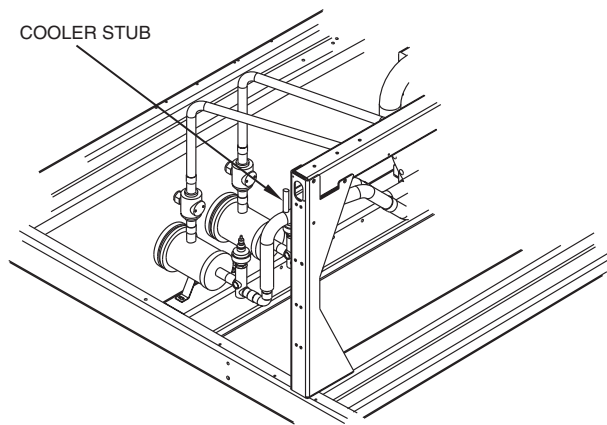

Fig. 3 — Stub Tube for Circuit A of Size 110

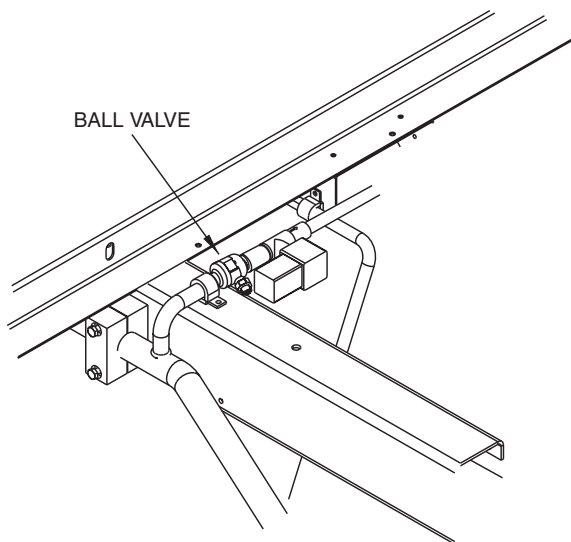

Fig. 4 — Typical View of $\frac{5}{8}$ in. Swage Tube, $\frac{5}{8}$ in. Clamp and Solenoid Valve Installed

Install Control Wiring (See Fig. 6 and 7)

1. One control wire harness is supplied per circuit. Secure the DIN connector end on the solenoid valve coil with the screw in the connector. Verify the square rubber gasket is in place to ensure connection remains watertight.
2. Route the other end of the cable to the main control panel (where the display is located). For the circuit A solenoid, connect leads to TB5-7 and TB5-13. For the B circuit solenoid, connect leads to TB5-8 and TB5-13. For the C circuit solenoid (30RB210-300 only), connect the leads to TB5-6 and TB5-13. In all cases the black wire from the solenoid must be connected to TB5-13 to ensure correct polarity. Incorrect polarity will damage the control boards.
3. For 30RB250-300 units only, locate Fan Board 3 (FB3) in the C circuit power control panel. Route the C circuit solenoid cable to the panel. Locate the orange and brown wires from channel 7 of connector J3 on this board. Connect the red wire from the solenoid to the orange wire from the board. Connect the black wire from the solenoid to the brown wire from the board.

Configure Unit for Minimum Load Control —

The control must be configured for the minimum load control operation. Use the Scrolling Marquee display to configure the system.

1. Set the Enable/Off/Remote switch to OFF position.
2. Press **ESCAPE** until the screen is blank and use the arrow key to select the Configuration mode LED.
3. Press **ENTER**, then use arrow key to select the sub-mode 'UNIT', then press Enter key.
4. Press the down arrow key until 'HGBP' is displayed.
5. Press **ENTER** key twice. The word 'PASS' and 'WORD' will flash.
6. Press 0 1 1 1 then **ENTER** key so that '0' flashes.
7. Use arrow keys to change value to one of the following configurations:

CONFIGURATION	DESCRIPTION
1	Used during chiller start-up only
2	Used during start-up and for close control of leaving fluid temperature
3	Used during start-up, for close control of the leaving fluid temperature and for high ambient unloading

8. Press the **ENTER** key.
9. Press the **ESCAPE** key until 'DISP' is displayed. Wait 10 seconds and cycle the control power using the On/Off switch.

The chiller is now configured for minimum load valve control.

Test Minimum Load Relay Output — Use the Scrolling Marquee display, the instructions given in the Controls, Start-Up, Operation Service and Troubleshooting manual and the Service Test mode to verify proper operation of the solenoid(s) (illuminate the Service Test LED, enter the TEST mode, enable the test request, 'T.REQ' and test outputs 'HGB.A,' 'HGB.B' and for 30RB210-300 only, 'HGB.C.'

Once the outputs have been tested, the installation is complete. Return the Enable/Off/Remote contact switch to the desired position.

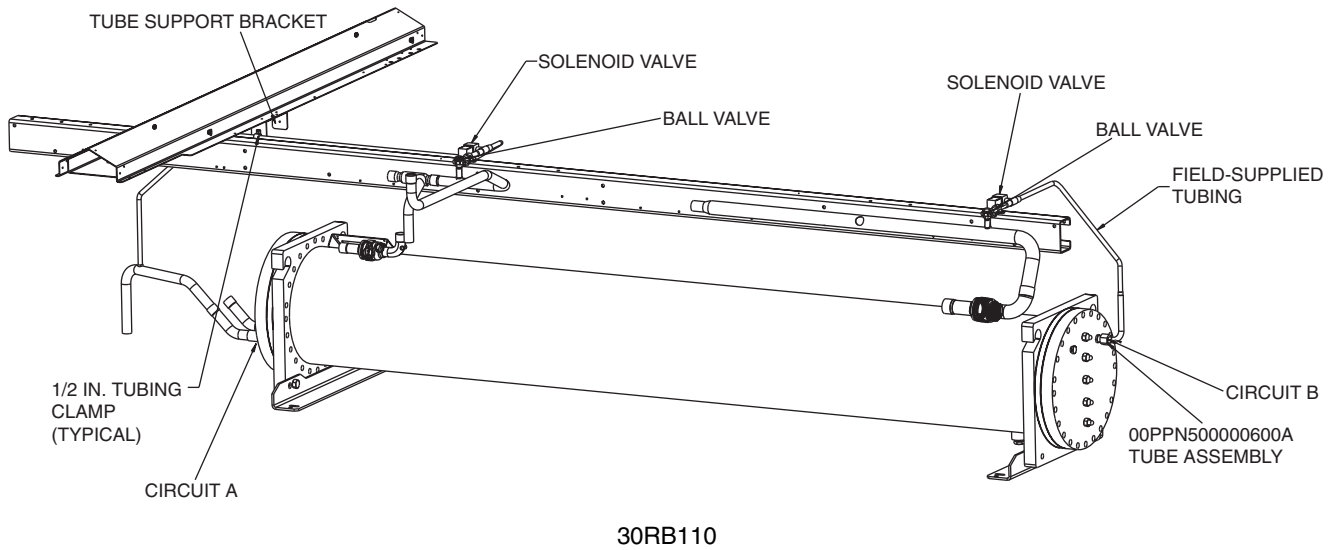
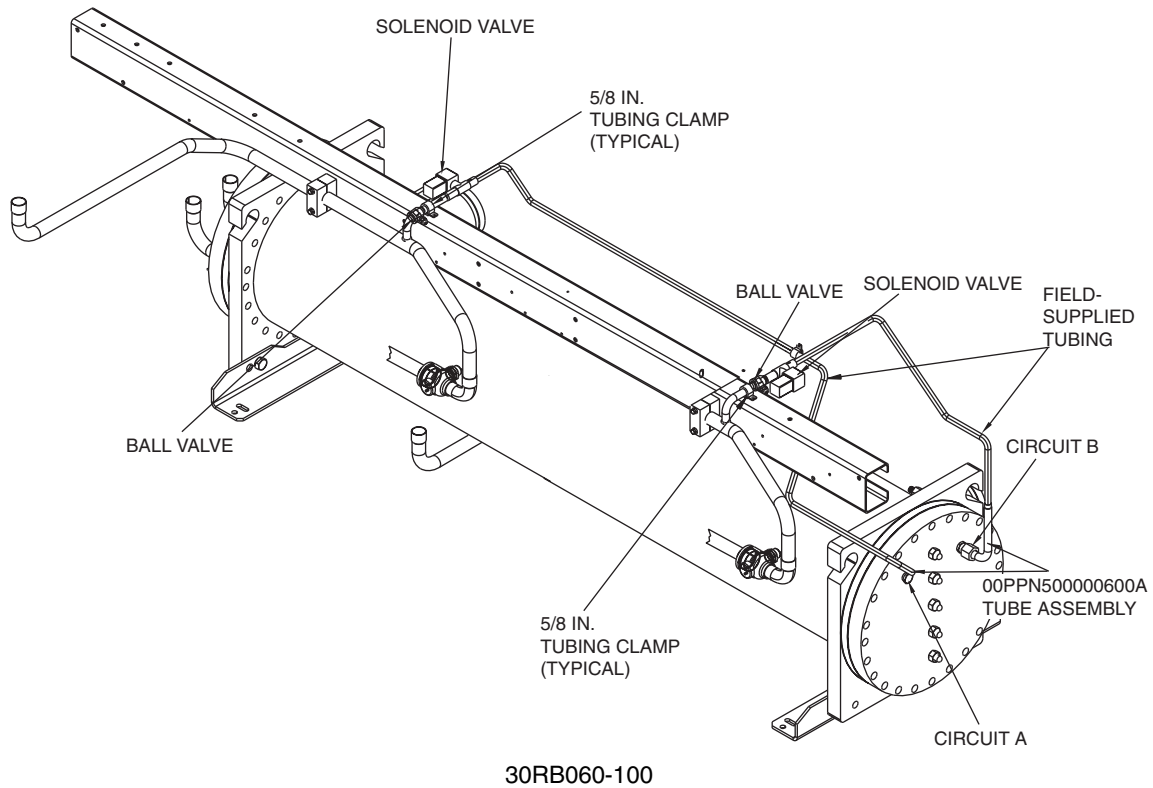
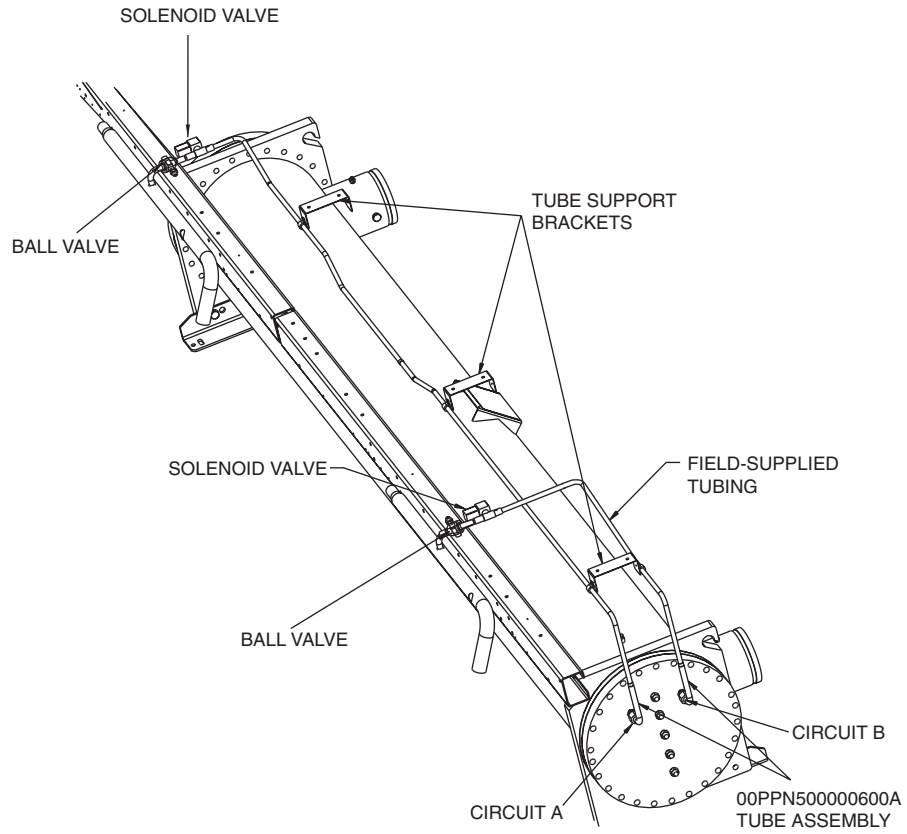
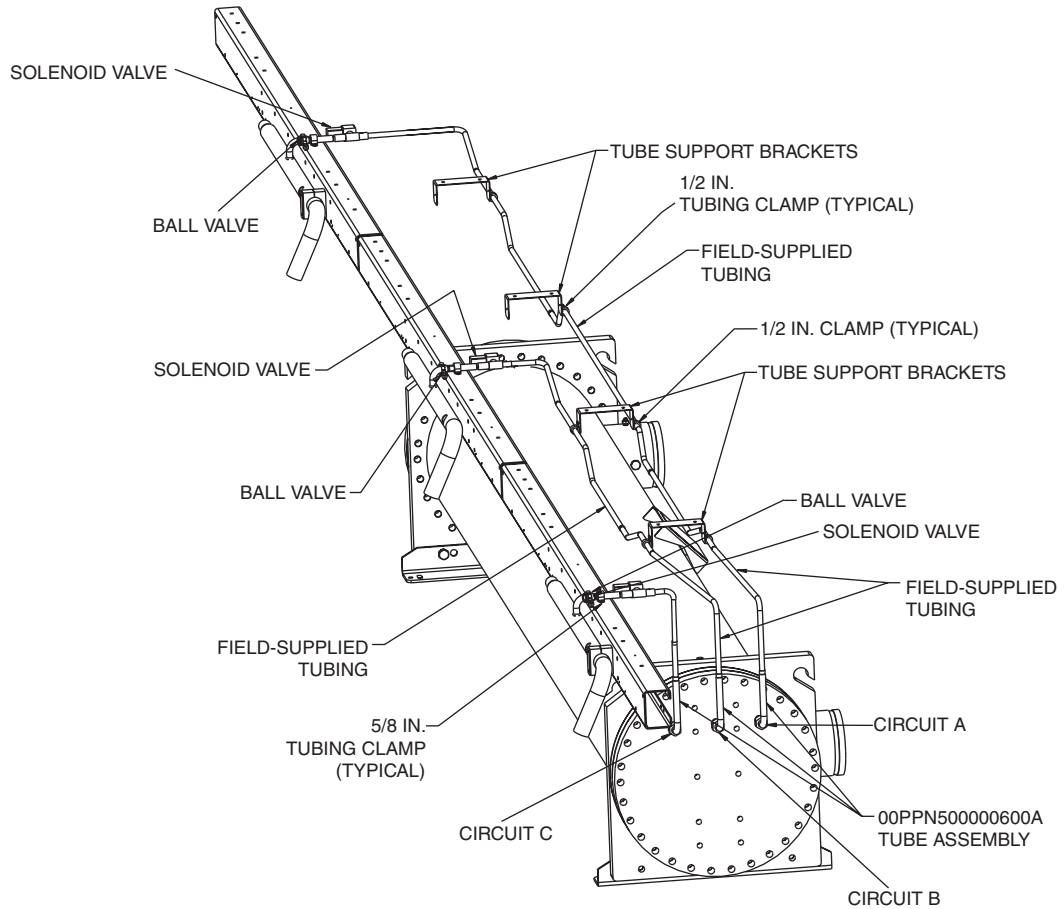

Fig. 5 — Typical Piping Brackets



30RB120-190



30RB210-300

Fig. 5 — Typical Piping Brackets (cont)

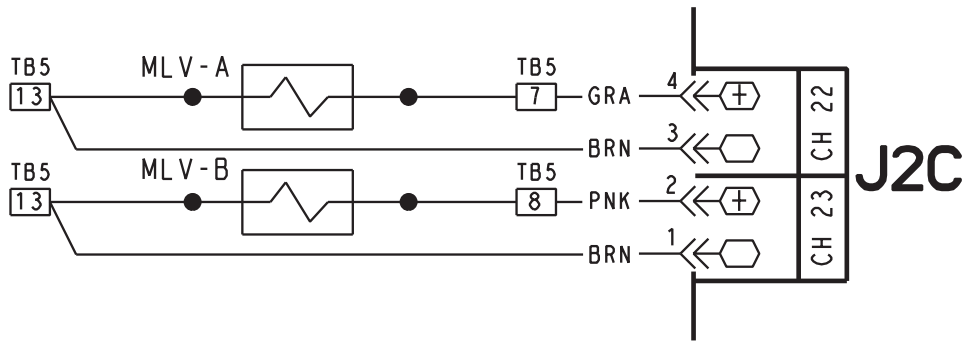

Fig. 6 — Main Base Board Wiring for Circuits A and B, 30RB060-300

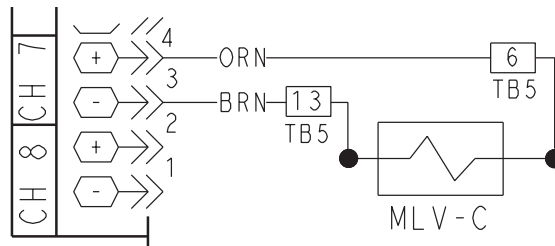

Fig. 7 — Fan Board 3 Wiring for Circuit C, 30RB210-300

