



# Installation Instructions

## SAFETY CONSIDERATIONS

**Screw liquid chillers are designed to provide safe and reliable service when operated within design specifications. When operating this equipment, use good judgment and safety precautions to avoid damage to equipment and property or injury to personnel.**

**Be sure you understand and follow the procedures and safety precautions contained in the machine instructions, as well as those listed in this guide.**

### ▲ DANGER

DO NOT VENT refrigerant relief devices within a building. Outlet from rupture disc or relief valve must be vented outdoors in accordance with the latest edition of ANSI/ASHRAE 15 (American National Standards Institute/American Society of Heating, Refrigeration and Air-Conditioning Engineers) (Safety Code for Mechanical Refrigeration). The accumulation of refrigerant in an enclosed space can displace oxygen and cause asphyxiation.

PROVIDE adequate ventilation in accordance with ANSI/ASHRAE 15, especially for enclosed and low overhead spaces. Inhalation of high concentrations of vapor is harmful and may cause heart irregularities, unconsciousness, or death. Intentional misuse can be fatal. Vapor is heavier than air and reduces the amount of oxygen available for breathing. Product causes eye and skin irritation. Decomposition products are hazardous.

DO NOT USE OXYGEN to purge lines or to pressurize a machine for any purpose. Oxygen gas reacts violently with oil, grease, and other common substances.

DO NOT USE air to leak test. Use only refrigerant or dry nitrogen. NEVER EXCEED specified test pressures. VERIFY the allowable test pressure by checking the instruction literature and the design pressures on the equipment nameplate.

DO NOT VALVE OFF any safety device.

BE SURE that all pressure relief devices are properly installed and functioning before operating any machine.

RISK OF INJURY OR DEATH by electrocution. High voltage is present on motor leads even though the motor is not running. Open the power supply disconnect before touching motor leads or terminals.

### ▲ WARNING

DO NOT WELD OR FLAMECUT any refrigerant line or vessel until all refrigerant (liquid and vapor) has been removed from chiller. Traces of vapor should be displaced with dry air or nitrogen and the work area should be well ventilated. *Refrigerant in contact with an open flame produces toxic gases.*

DO NOT USE eyebolts or eyebolt holes to rig heat exchangers or the entire assembly.

DO NOT work on high-voltage equipment unless you are a qualified electrician.

DO NOT WORK ON electrical components, including control panels, switches, starters, or oil heater until you are sure ALL POWER IS OFF and no residual voltage can leak from capacitors or solid-state components.

LOCK OPEN AND TAG electrical circuits during servicing. IF WORK IS INTERRUPTED, confirm that all circuits are deenergized before resuming work.

AVOID SPILLING liquid refrigerant on skin or getting it into the eyes. USE SAFETY GOGGLES. Wash any spills from the skin with soap and water. If liquid refrigerant enters the eyes, IMMEDIATELY FLUSH EYES with water and consult a physician.

NEVER APPLY an open flame or live steam to a refrigerant cylinder. Dangerous over pressure can result. When it is necessary to heat refrigerant, use only warm (110 F [43 C]) water.

DO NOT REUSE disposable (nonreturnable) cylinders or attempt to refill them. It is DANGEROUS AND ILLEGAL. When cylinder is emptied, evacuate remaining gas pressure, loosen the collar, and unscrew and discard the valve stem. DO NOT INCINERATE.

CHECK THE REFRIGERANT TYPE before adding refrigerant to the machine. The introduction of the wrong refrigerant can cause machine damage or malfunction.

Operation of this equipment with refrigerants other than those cited herein should comply with ANSI/ASHRAE 15 (latest edition). Contact Carrier for further information on use of this machine with other refrigerants.

DO NOT ATTEMPT TO REMOVE fittings, covers, etc., while machine is under pressure or while machine is running. Be sure pressure is at 0 psig (0 kPa) before breaking any refrigerant connection.

CAREFULLY INSPECT all relief valves, rupture discs, and other relief devices AT LEAST ONCE A YEAR. If machine operates in a corrosive atmosphere, inspect the devices at more frequent intervals.

DO NOT ATTEMPT TO REPAIR OR RECONDITION any relief valve when corrosion or build-up of foreign material (rust, dirt, scale, etc.) is found within the valve body or mechanism. Replace the valve.

DO NOT install relief devices in series or backwards.

USE CARE when working near or in line with a compressed spring. Sudden release of the spring can cause it and objects in its path to act as projectiles.

### ▲ CAUTION

DO NOT STEP on refrigerant lines. Broken lines can whip about and release refrigerant, causing personal injury.

DO NOT climb over a machine. Use platform, catwalk, or staging. Follow safe practices when using ladders.

USE MECHANICAL EQUIPMENT (crane, hoist, etc.) to lift or move inspection covers or other heavy components. Even if components are light, use mechanical equipment when there is a risk of slipping or losing your balance.

BE AWARE that certain automatic start arrangements CAN ENGAGE THE STARTER, TOWER FAN, OR PUMPS. Open the disconnect *ahead of* the starter, tower fan, and pumps. Shut off the machine or pump before servicing equipment.

USE only repaired or replacement parts that meet the code requirements of the original equipment.

DO NOT VENT OR DRAIN waterboxes containing industrial brines, liquid, gases, or semisolids without the permission of your process control group.

DO NOT LOOSEN waterbox cover bolts until the waterbox has been completely drained.

DOUBLE-CHECK that coupling nut wrenches, dial indicators, or other items have been removed before rotating any shafts.

DO NOT LOOSEN a packing gland nut before checking that the nut has a positive thread engagement.

PERIODICALLY INSPECT all valves, fittings, and piping for corrosion, rust, leaks, or damage.

PROVIDE A DRAIN connection in the vent line near each pressure relief device to prevent a build-up of condensate or rain water.

## CONTENTS

	Page
<b>SAFETY CONSIDERATIONS</b> .....	1
<b>INTRODUCTION</b> .....	2
<b>General</b> .....	2
<b>Job Data</b> .....	2
<b>INSTALLATION</b> .....	2-42
<b>Receiving the Machine</b> .....	2
• INSPECT SHIPMENT	
• IDENTIFY MACHINE	
• INSTALLATION REQUIREMENTS	
• PROVIDE MACHINE PROTECTION	
<b>Rigging the Machine</b> .....	3
• RIG MACHINE ASSEMBLY	
• RIG MACHINE COMPONENTS	
<b>Separate Machine Components</b> .....	13
• SEPARATE COOLER AND CONDENSER	
• REMOVE THE CONTROLS/DRIVE ENCLOSURE FROM THE CONDENSER	
• REMOVE THE DISCHARGE PIPE ASSEMBLY FROM THE CONDENSER	
• SEPARATE THE COMPRESSOR FROM THE CONDENSER	
• SEPARATE THE VAPORIZER FROM THE CONDENSER	
<b>VFD Installation</b> .....	19
<b>Install Machine Supports</b> .....	22
• INSTALL STANDARD ISOLATION	
• INSTALL ACCESSORY ISOLATION	
• INSTALL SPRING ISOLATION	
<b>Connect Piping</b> .....	24
• INSTALL WATER PIPING TO HEAT EXCHANGERS	
• INSTALL VENT PIPING TO RELIEF VALVES	
<b>Make Electrical Connections</b> .....	30
• GROUNDING THE CONTROLS/DRIVE ENCLOSURE	
• INSTALLING INPUT POWER WIRING	
• WIRING THE FIELD WIRING TERMINAL STRIPS	
• CONNECT CONTROL INPUTS	
• CONNECT CONTROL OUTPUTS	
• CONNECT STARTER	
<b>COMPLETING THE INSTALLATION</b> .....	43-47
<b>Checking the Installation</b> .....	43
<b>Oil Pump and Oil Heater</b> .....	43
<b>Connect Control Wiring</b> .....	43
<b>Carrier Comfort Network Interface</b> .....	43
<b>Lead-Lag Control Wiring</b> .....	44
<b>Install Field Insulation and Lagging</b> .....	44
<b>INSTALLATION START-UP REQUEST CHECKLIST</b> .....	CL-1, CL-2

## INTRODUCTION

**General** — The 23XRV machine is factory assembled, wired, and leak tested. Installation (not by Carrier) consists primarily of establishing water and electrical services to the machine. The rigging, installation, field wiring, field piping, and insulation of waterbox covers are the responsibility of the contractor and/or customer. Carrier has no installation responsibilities for the equipment.

**Job Data** — Necessary information consists of:

- job contract or specifications
- machine location prints
- rigging information
- piping prints and details
- field wiring drawings
- starter manufacturer's installation details
- Carrier certified print

## INSTALLATION

### Receiving the Machine


#### INSPECT SHIPMENT

#### ⚠ CAUTION

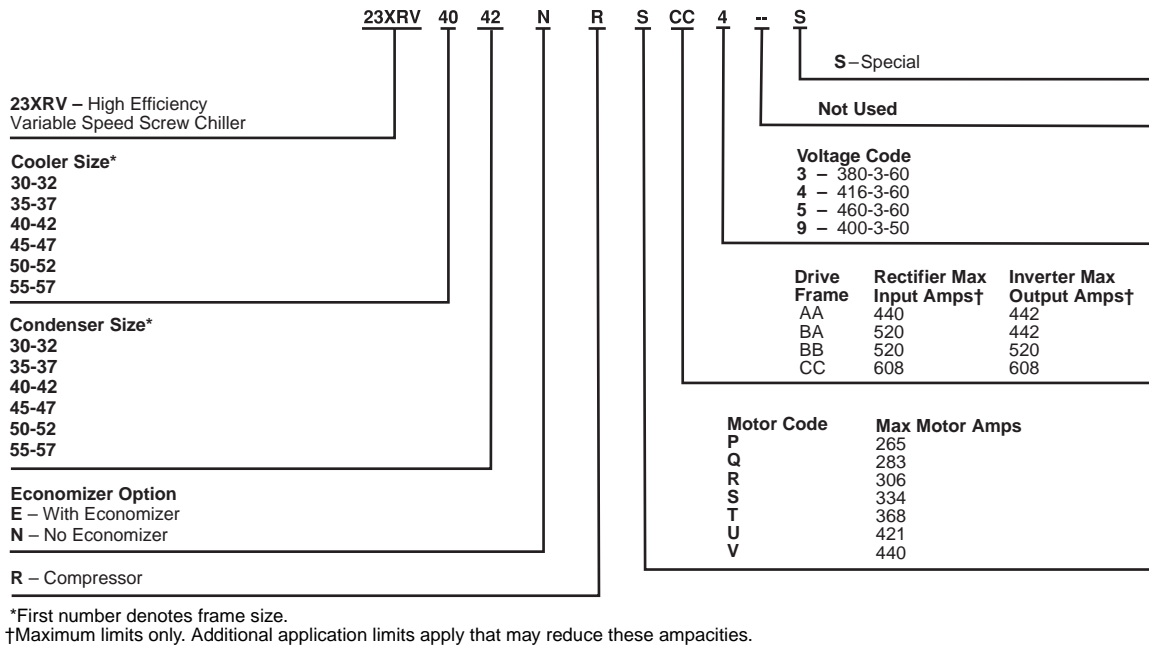
Do not open any valves or loosen any connections. The 23XRV machine may be shipped with a full refrigerant charge. Some machines may be shipped with a nitrogen holding charge as an option.

1. Inspect for shipping damage while machine is still on shipping conveyance. If machine appears to be damaged or has been torn loose from its anchorage, have it examined by transportation inspectors before removal. Forward claim papers directly to transportation company. *Manufacturer is not responsible for any damage incurred in transit.*
2. Check all items against shipping list. Immediately notify the nearest Carrier representative if any item is missing.
3. To prevent loss or damage, leave all parts in original packages until beginning installation. All openings are closed with covers or plugs to prevent dirt and debris from entering machine components during shipping. A full operating oil charge is placed in the oil sump before shipment.

**IDENTIFY MACHINE** (Fig. 1-4) — Refer to machine nameplate in Fig. 1. The machine model number, serial number, and heat exchanger sizes are stamped on the Refrigeration Machine nameplate located on the side of the VFD (variable frequency drive) enclosure. Check this information against shipping papers and job data.

 <b>Carrier</b> <small>A United Technologies Company</small>		
<b>REFRIGERATION MACHINE</b>		
	MODEL NUMBER	SERIAL NO.
MACHINE		
COMPRESSOR		
COOLER		
CONDENSER		
ECON		
STOR TANK		
VFD		
REFRIGERANT	LBS.      KGS.	
<b>R-</b>	CHARGED	
TEST PRESSURE	PSI	KPA
DESIGN PRESSURE	PSI	KPA
CLR. WATER PRESSURE	PSI	KPA
COND. WATER PRESSURE	PSI	KPA
RATED TONS		
RATED IKW		
NAMEPLATE VOLTS/PHASE/HERTZ		
UTILIZATION VOLTAGE		
MIN CIRCUIT AMPACITY		
CARRIER CHARLOTTE 9701 OLD STATESVILLE ROAD CHARLOTTE, NORTH CAROLINA 28269 ASSEMBLED IN USA PRODUCTION YEAR, 20XX		
<b>SAFETY CODE CERTIFICATION</b>		
<small>THIS UNIT IS DESIGNED, CONSTRUCTED, AND TESTED IN CONFORMANCE WITH ANSI/ASHRAE 15 (LATEST REVISION), SAFETY CODE FOR MECHANICAL REFRIGERATION. THE COMPRESSOR MOTOR CONTROLLER AND OVERLOAD PROTECTION MUST BE IN ACCORDANCE WITH CARRIER SPECIFICATION Z-420.</small>		
		<small>230000001 REV. 5.0</small>

**Fig. 1 — Refrigeration Machine Nameplate**



**Fig. 2 — Model Number Identification**

**Identifying the Drive by Part Number** — Each LiquiFlo™ 2.0 AC drive can be identified by its part number. See Fig. 5. This number appears on the shipping label and on the VFD nameplate.

**Drive Input Component Location** — Figure 6 identifies the control center components.

**Identifying the Power Module by I.D. Number** — Each LiquiFlo 2.0 AC power module can be identified by its I.D. number. See Fig. 5. This number appears on the shipping label and on the power module's nameplate. Power ratings are provided in Table 1.

**INSTALLATION REQUIREMENTS** — Certain requirements should be checked before continuing with the chiller's electrical installation. Input power wire sizes, branch circuit protection, and control wiring are all areas that need to be evaluated.

**Determining Wire Size Requirements** — Wire size should be determined based on the size of the conduit openings, and applicable local, national, and international codes (e.g., NEC [National Electric Code]/CEC [California Energy Commission] regulations). General recommendations are included in the Carrier field wiring drawing.

**Conduit Entry Size** — It is important to determine the size of the conduit openings in the enclosure power entry plate so that the wire planned for a specific entry point will fit through the opening. Do NOT punch holes or drill into the top surface of the control center enclosure for field wiring. Do not punch holes or drill into the top surface of the control center enclosure for field wiring. Knockouts are provided in the back of the control center for field control wiring connections.

**Recommended Control and Signal Wire Sizes** — The recommended minimum size wire to connect I/O signals to the control terminal blocks is 18 AWG (American Wire Gage). Recommended terminal tightening torque is 7 to 9 in.-lb (0.79 to 1.02 N-m).

**Recommended Air Flow Clearances** — Be sure there is adequate clearance for air circulation around the enclosure. A 6-in. (152.4 mm) minimum clearance is required wherever vents are located in the VFD enclosure.

**Match Power Module Input and Supply Power Ratings** — It is important to verify that building power will meet the input power requirements of the Machine Electrical Data nameplate

input power rating. Be sure the input power to the chiller corresponds to the chiller's nameplate voltage, current, and frequency. Refer to machine nameplate in Fig. 7. The machine electrical data nameplate is located on the right side of the control center.

**PROVIDE MACHINE PROTECTION** — Protect machine and VFD enclosure from construction dirt and moisture. Keep protective shipping covers in place until machine is ready for installation.

If machine is exposed to freezing temperatures after water circuits have been installed, open waterbox drains and remove all water from cooler and condenser. Leave drains open until system is filled.

It is important to properly plan before installing a 23XRV unit to ensure that the environment and operating conditions are satisfactory. The installation must comply with all requirements in the certified prints.

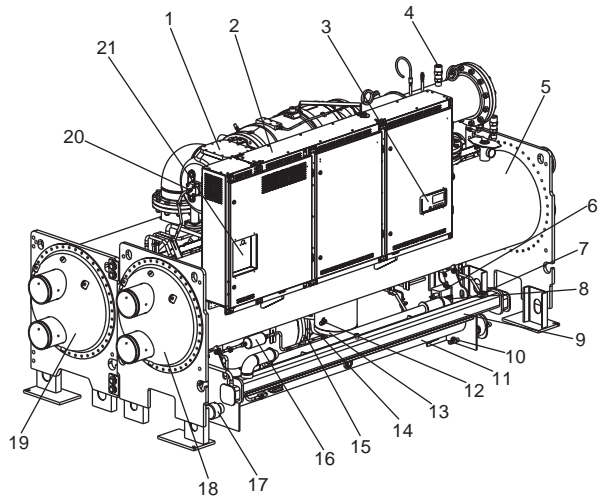
**Rigging the Machine** — The 23XRV machine can be rigged as an entire assembly. Large interconnecting piping has flanged connections that allow the compressor, cooler, and condenser sections to be separated and rigged individually. In addition, the VFD can be removed and rigged separately.

**RIG MACHINE ASSEMBLY** — See rigging instructions on label attached to machine. Also refer to rigging guide (Fig. 8), physical data in Fig. 9, and Tables 2-9B. *Lift machine only from the points indicated in rigging guide.* Each lifting cable or chain must be capable of supporting the entire weight of the machine.

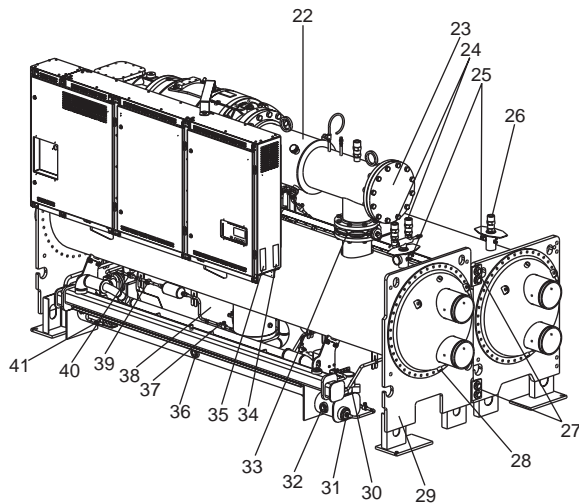
**▲ WARNING**

Lifting machine from points other than those specified may result in serious damage to the unit and personal injury. Rigging equipment and procedures must be adequate for machine weight. See Fig. 8 for machine weights.

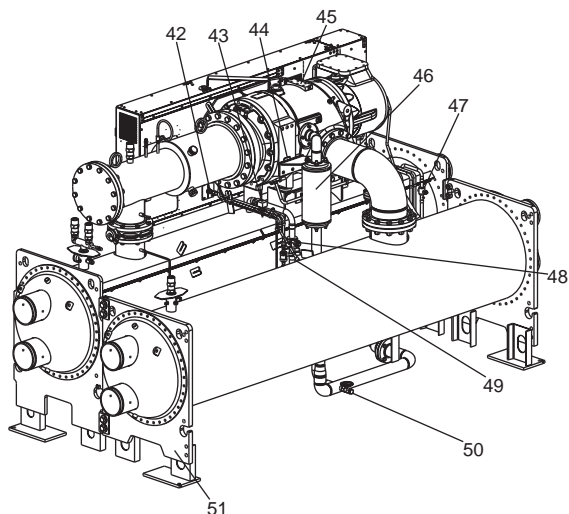
NOTE: These weights are broken down into component sections for use when installing the unit in sections. For the complete machine weight, add all component sections and refrigerant charge together. See Tables 5-9B for machine component weights.



- 1 — Motor Terminal Cover Plate
- 2 — Variable Frequency Drive
- 3 — International Chiller Visual Controller (ICVC)
- 4 — Discharge Pipe Relief Valve
- 5 — Condenser
- 6 — Oil Reclaim Actuator
- 7 — Vaporizer Sight Glass
- 8 — Oil Filter Assembly (Hidden)
- 9 — Vaporizer
- 10 — Oil Charging/Drain Valve
- 11 — Oil Sump
- 12 — Condenser Refrigerant Pumpout Valve
- 13 — Condenser Float Chamber
- 14 — Cooler Inlet Isolation Valve
- 15 — ASME Nameplate, Economizer (Hidden)
- 16 — Filter Drier
- 17 — Oil Sump Heater
- 18 — Condenser Supply/Return End Waterbox
- 19 — Cooler Supply/Return End Waterbox
- 20 — Motor Cooling Supply Line
- 21 — VFD Disconnect

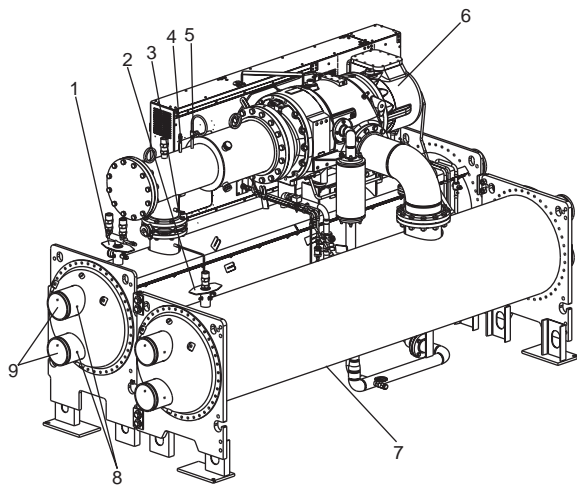


- 22 — Discharge Pipe
- 23 — Compressor Discharge Check Valve Access Cover
- 24 — Condenser Relief Valves
- 25 — Refrigerant Charging Valve
- 26 — Cooler Relief Valve
- 27 — Tubesheet Mounting Brackets
- 28 — Typical Waterbox Drain Coupling
- 29 — ASME Nameplate, Condenser
- 30 — Oil Pump
- 31 — Oil Pump Inlet Strainer
- 32 — Strainer Housing Sight Glass
- 33 — Discharge Isolation Valve (Option or Accessory)
- 34 — Refrigeration Machine Nameplate
- 35 — Machine Electrical Data Nameplate
- 36 — Oil Sump Sight Glass
- 37 — Filter Drier Isolation Valve with Schrader
- 38 — Economizer
- 39 — Motor Cooling Sight Glass
- 40 — Motor Cooling Isolation Valve
- 41 — Vaporizer Drain Sight Glass

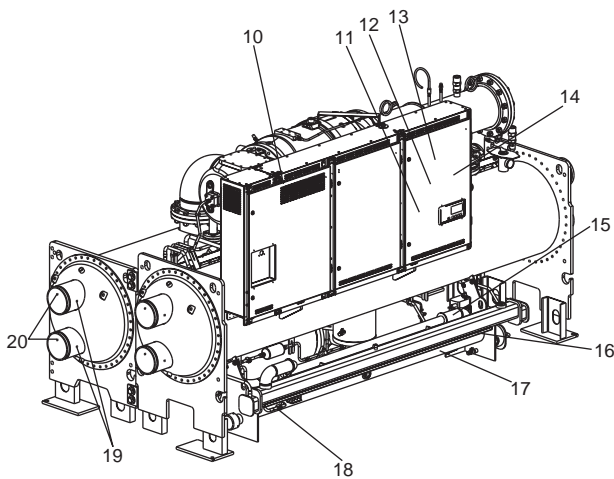


- 42 — VFD Cold Plate Refrigeration Inlet Connection (Outlet Hidden)
- 43 — VFD Cold Plate Solenoid
- 44 — Compressor Nameplate
- 45 — Compressor Lubrication Block
- 46 — Economizer Muffler
- 47 — Vaporizer Condenser Gas Isolation Valve
- 48 — Hot Gas Bypass Isolation and Trim Valve
- 49 — VFD Cooling Refrigerant Strainer
- 50 — Cooler Refrigerant Pumpout Valve
- 51 — ASME Nameplate, Cooler

**Fig. 3 — Typical 23XRV Components**



- 1 — Condenser Pressure
- 2 — Evaporator Pressure
- 3 — Compressor Discharge Temperature
- 4 — Compressor Discharge Pressure
- 5 — Compressor Discharge High Pressure Switch
- 6 — Compressor Motor Winding Temperature (Hidden)
- 7 — Evaporator Refrigerant Liquid Temperature (Hidden)
- 8 — Condenser Liquid Temperature
- 9 — Condenser Liquid Flow (Optional)



- 10 — Inductor Temperature Switch (Inside VFD Enclosure)
- 11 — VFD Rectifier Temperature (Inside Power Module)
- 12 — VFD Cold Plate Temperature (Inside VFD Enclosure)
- 13 — VFD Inverter Temperature (Inside Power Module)
- 14 — Humidity Sensor (Inside VFD Enclosure)
- 15 — Oil Pressure Leaving Filter (Hidden)
- 16 — Oil Sump Pressure (Hidden)
- 17 — Oil Sump Temperature (Hidden)
- 18 — Vaporizer Temperature
- 19 — Evaporator Liquid Temperature
- 20 — Evaporator Liquid Flow (Optional)

Fig. 4 — Typical 23XRV Installation (Sensor Locations)

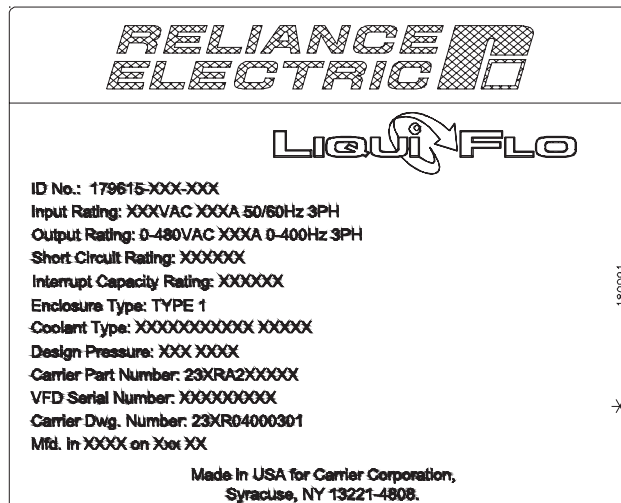
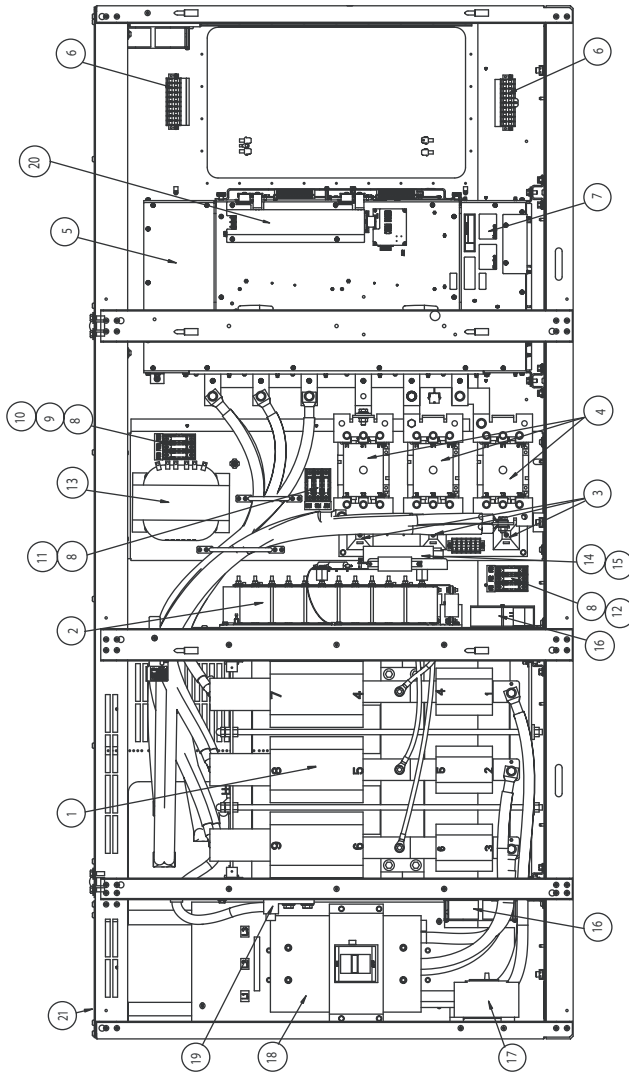



Fig. 5 — VFD Nameplate



- |    |   |                                 |    |   |                                |
|----|---|---------------------------------|----|---|--------------------------------|
| 1  | — | Input Inductor Assembly         | 12 | — | Fuse, Class CC, 600V, 1A (3)   |
| 2  | — | Capacitor Bank Assembly         | 13 | — | Transformer, 3kVA              |
| 3  | — | Pre-Charge Resistor Assembly    | 14 | — | Line Sync PC Board Assembly    |
| 4  | — | AC Contactor (3)                | 15 | — | Line Sync Board Cover          |
| 5  | — | Power Module Assembly           | 16 | — | Fan, 115V (3)                  |
| 6  | — | Terminal Block, 10-Position (2) | 17 | — | Circuit Breaker, 600V, 15A     |
| 7  | — | Power Module Nameplate          | 18 | — | Circuit Breaker, 600V          |
| 8  | — | Fuse Block, 30A, 600V, Class CC | 19 | — | Lug, Ground, 2-600 MCM         |
| 9  | — | Fuse, Class CC, 600V, 15A (2)   | 20 | — | Communications Interface Board |
| 10 | — | Fuse, Class CC, 600V, 5A (1)    | 21 | — | Input Power Wiring Panel       |
| 11 | — | Fuse, Class CC, 600V, 20A (3)   |    |   |                                |

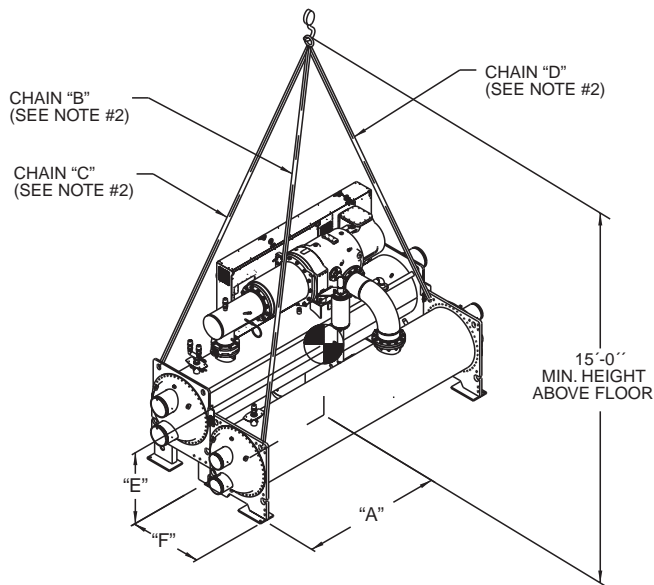
**Fig. 6 — Control Center Components**

 <b>Carrier</b> <small>A United Technologies Company</small>	
<b>MODEL NUMBER</b>	
<b>SERIAL NUMBER</b>	
<b>MACHINE NAMEPLATE SUPPLY DATA</b>	
VOLTS/PHASE/HERTZ	
LOCKED ROTOR AMPS	
OVERLOAD TRIP AMPS	
MAX FUSE/CIRCUIT BREAKER SIZE	
MIN SUPPLY CIRCUIT AMPACITY	
<b>MACHINE ELECTRICAL DATA</b>	
MOTOR NAMEPLATE VOLTAGE	480V
COMPRESSOR 100% SPEED	
RATED LINE VOLTAGE	
RATED LINE AMPS	
RATED LINE KILOWATTS	
MOTOR RATED LOAD KW	
MOTOR RATED LOAD AMPS	
MOTOR NAMEPLATE AMPS	
MOTOR NAMEPLATE RPM	
MOTOR NAMEPLATE KW	
INVERTER PWM FREQUENCY	
<b>CONTROLS, OIL PUMP AND HEATER DATA</b>	
CONTROLS, OIL PUMP AND HEATER CIRCUIT	115V
MAX FUSE SIZE	15A
MIN CIRCUIT AMPACITY	15A
OIL PUMP	115V, 1.48A
OIL SUMP HEATER	115V, 4.35A, 500W
OIL VAPORIZER HTR CIRCUIT	115V
MAX FUSE SIZE	15A
MIN CIRCUIT AMPACITY	15A
OIL VAPORIZER HEATER	115V, 13.04A, 1500W
<small>CARRIER CHARLOTTE            9701 OLD STATESVILLE ROAD            CHARLOTTE, NORTH CAROLINA 28269            PRODUCTION YEAR 20XX            23XK05503001 REV. 4.0</small>	

**Fig. 7 — Machine Electrical Data Nameplate**

HEAT EXCHANGER CODE	COMPRESSOR FRAME SIZE*	MAXIMUM WEIGHT (lb)	VESSEL LENGTH	DIM. "A"	CHAIN LENGTH			DIM. "E"	DIM. "F"
					"B"	"C"	"D"		
30-32	R	19,187	12'	6'-10"	13'- 5"	13'-0"	12'- 5"	3'-11"	3'- 8"
35-37		20,589	14'	7'- 8"	13'-10"	13'-5"	12'-10"	3'-11"	3'- 8"
40-42		23,928	12'	6'-10"	13'- 6"	12'-8"	12'- 3"	4'- 1"	3'-11"
45-47		25,167	14'	7'- 8"	13'-11"	13'-2"	12'- 8"	4'- 1"	3'-11"
50-52		26,950	12'	6'-10"	13'-10"	12'-7"	12'- 9"	4'- 0"	4'- 4"
55-57		28,479	14'	7'- 8"	14'- 4"	13'-1"	13'- 1"	4'- 0"	4'- 4"

\*The 11th character of the chiller model number indicates the frame size of the compressor.

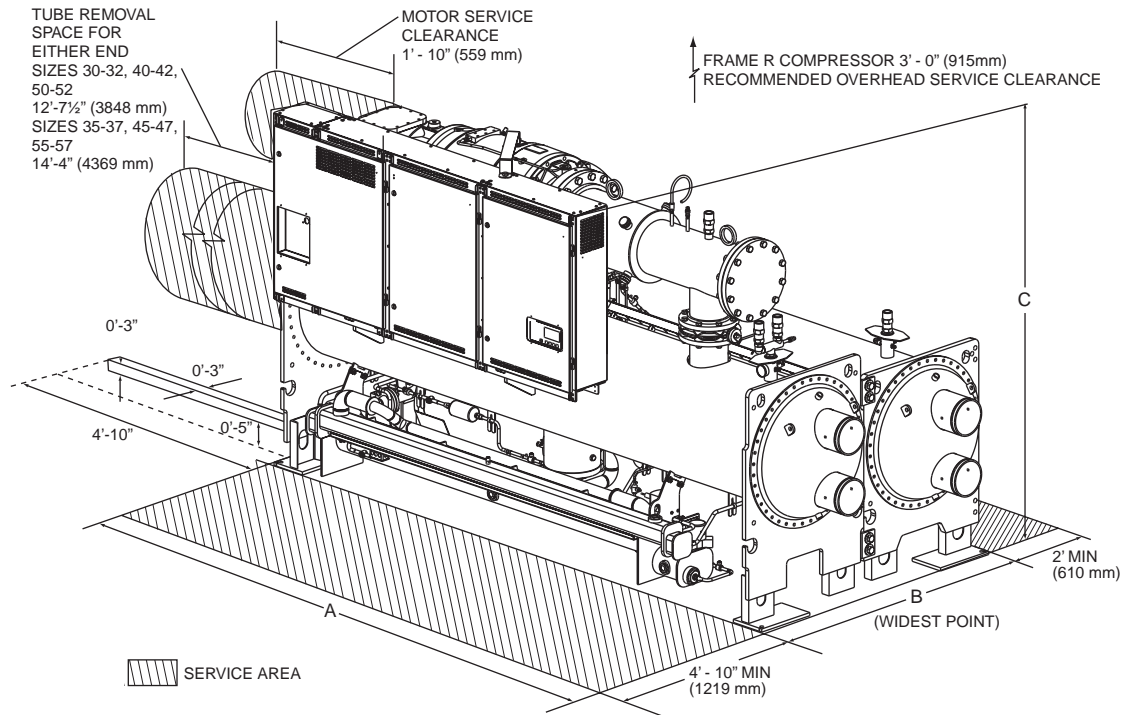


**MACHINE RIGGING GUIDE**

**NOTES:**

1. Each chain must be capable of supporting the entire weight of the machine. See chart for maximum weights.
2. Chain lengths shown are typical for 15' lifting height. Some minor adjustments may be required.

**Fig. 8 — Machine Rigging Guide (Cooler Size 30 Through 57)**



**Fig. 9 — 23XRV Dimensions (Refer to Tables 2 and 3)**

**Table 1 — Drive Assembly and Power Module Ratings**

CARRIER PART NUMBER	FRAME SIZE	ENCLOSURE TYPE	INPUT VOLTAGE (V) RANGE	MAX INPUT CURRENT (AMPS)	MAX OUTPUT CURRENT* at 4kHz (AMPS)
23XRA2AA	Frame 2AA	NEMA 1	380 to 460	440	442
23XRA2BA	Frame 2BA	NEMA 1	380 to 460	520	442
23XRA2BB	Frame 2BB	NEMA 1	380 to 460	520	520
23XRA2CC	Frame 2CC	NEMA 1	380 to 460	608	608

\*110% output current capability for one minute, 150% output current for 5 seconds.

**Table 2 — 23XRV Dimensions (Nozzle-In-Head Waterbox)**

HEAT EXCHANGER SIZE	A (Length, with Nozzle-in-Head Waterbox)						B (Width)		C (Height)	
	1 Pass		2-Pass*		3 Pass†		ft-in.	mm	ft-in.	mm
	ft-in.	mm	ft-in.	mm	ft-in.	mm				
30 to 32	14- 3 <sup>1</sup> / <sub>4</sub>	4350	13- 8 <sup>1</sup> / <sub>4</sub>	4172	14- 3 <sup>1</sup> / <sub>4</sub>	4350	6- 4	1930	7-2 <sup>5</sup> / <sub>8</sub>	2200
35 to 37	15-11 <sup>3</sup> / <sub>4</sub>	4870	15- 4 <sup>3</sup> / <sub>4</sub>	4693	15-11 <sup>3</sup> / <sub>4</sub>	4870	6- 4	1930	7-2 <sup>5</sup> / <sub>8</sub>	2200
40 to 42	14- 9	4496	14- 3 <sup>1</sup> / <sub>8</sub>	4347	14- 6	4420	6- 8 <sup>1</sup> / <sub>2</sub>	2045	7-6 <sup>1</sup> / <sub>2</sub>	2299
45 to 47	16- 5 <sup>1</sup> / <sub>2</sub>	5017	15-11 <sup>5</sup> / <sub>8</sub>	4867	16- 2 <sup>1</sup> / <sub>2</sub>	4940	6- 8 <sup>1</sup> / <sub>2</sub>	2045	7-6 <sup>1</sup> / <sub>2</sub>	2299
50 to 52	14-10	4521	14- 4 <sup>1</sup> / <sub>2</sub>	4382	14- 6 <sup>1</sup> / <sub>2</sub>	4432	6-11 <sup>3</sup> / <sub>4</sub>	2127	7-6 <sup>3</sup> / <sub>4</sub>	2305
55 to 57	16- 6 <sup>1</sup> / <sub>2</sub>	5042	16- 1	4902	16- 3	4953	6-11 <sup>3</sup> / <sub>4</sub>	2127	7-6 <sup>3</sup> / <sub>4</sub>	2305

\*Assumes both cooler and condenser nozzles on same end of chiller.

†1 or 3 pass length applies if either (or both) cooler or condenser is a 1 or 3 pass design.

**NOTES:**

- Service access should be provided per American Society of Heating, Refrigeration, and Air Conditioning Engineers (ASHRAE) 15, latest edition, National Fire Protection Association (NFPA) 70, and local safety code.
- Allow at least 3 ft (915 mm) overhead clearance for service rigging for frame R compressor.
- Certified drawings available upon request.
- Marine waterboxes may add 6 in. to the width of the machine. See certified drawings for details.
- 'A' length dimensions shown are for standard 150 psi design and victaulic connections. The 300 psi design and/or flanges will add length. See certified drawings.
- Dished head waterbox covers not available for 3 pass design.

**Table 3 — 23XRV Dimensions (Marine Waterbox)**

HEAT EXCHANGER SIZE	A (Length, Marine Waterbox — not shown)				MAXIMUM B WIDTH		MAXIMUM C HEIGHT	
	2-Pass*		1 or 3 Pass†		ft-in.	mm	ft-in.	mm
	ft-in.	mm	ft-in.	mm				
<b>30 to 32</b>	14- 9	4496	16-4 <sup>3</sup> / <sub>4</sub>	4997	6-9 <sup>3</sup> / <sub>8</sub>	2067	7-2 <sup>5</sup> / <sub>8</sub>	2200
<b>35 to 37</b>	16- 5 <sup>1</sup> / <sub>2</sub>	5017	18-1 <sup>1</sup> / <sub>4</sub>	5518	6-9 <sup>3</sup> / <sub>8</sub>	2067	7-2 <sup>5</sup> / <sub>8</sub>	2200
<b>40 to 42</b>	15- 2 <sup>3</sup> / <sub>4</sub>	4642	16-8 <sup>1</sup> / <sub>4</sub>	5086	6-9 <sup>3</sup> / <sub>4</sub>	2076	7-6 <sup>1</sup> / <sub>2</sub>	2299
<b>45 to 47</b>	16-11 <sup>1</sup> / <sub>4</sub>	5163	18-4 <sup>3</sup> / <sub>4</sub>	5607	6-9 <sup>3</sup> / <sub>4</sub>	2076	7-6 <sup>1</sup> / <sub>2</sub>	2299
<b>50 to 52</b>	15- 3 <sup>1</sup> / <sub>2</sub>	4661	16-8 <sup>1</sup> / <sub>2</sub>	5093	7-1	2159	7-6 <sup>3</sup> / <sub>4</sub>	2305
<b>55 to 57</b>	17- 0	5182	18-5	5613	7-1	2159	7-6 <sup>3</sup> / <sub>4</sub>	2305

\*Assumes both cooler and condenser nozzles on same end of chiller.

†1 or 3 pass length applies if cooler is a 1 or 3 pass design.

**NOTES:**

1. Service access should be provided per American Society of Heating, Refrigeration, and Air Conditioning Engineers (ASHRAE) 15, latest edition, National Fire Protection Association (NFPA) 70, and local safety code.
2. Allow at least 3 ft (915 mm) overhead clearance for service rigging for frame R compressor.
3. Certified drawings available upon request.
4. Marine waterboxes may add 6 in. to the width of the machine. See certified drawings for details.
5. 'A' length and 'B' width dimensions shown are for standard 150 psi design and victaulic connections. The 300 psi design and/or flanges will add length. See certified drawings.

**Table 4 — 23XRV Waterbox Nozzle Sizes**

FRAME SIZE	PRESSURE psig (kPa)	PASS	NOMINAL PIPE SIZE (in.)		ACTUAL PIPE ID (in.)	
			Cooler	Condenser	Cooler	Condenser
<b>3</b>	150/300 (1034/2068)	1	10	10	10.020	10.020
		2	8	8	7.981	7.981
		3	6	6	6.065	6.065
<b>4</b>	150/300 (1034/2068)	1	10	10	10.020	10.020
		2	8	8	7.981	7.981
		3	6	6	6.065	6.065
<b>5</b>	150/300 (1034/2068)	1	10	10	10.020	10.020
		2	8	10	7.981	10.020
		3	6	8	6.065	7.981

**Table 5 — 23XRV Compressor Weights**

MOTOR CODE	ENGLISH	SI
	Total Compressor Weight* (lb)	Total Compressor Weight* (kg)
P	4866	2207
Q		
R		
S		
T		
U		
V		

\*Compressor weight is comprised of compressor, stator, rotor, and end bell.

**Table 6 — 23XRV Component Weights — TR Compressor**

COMPONENT	FRAME 3 HEAT EXCHANGER*		FRAME 4 HEAT EXCHANGER*		FRAME 5 HEAT EXCHANGER*	
	lb	kg	lb	kg	lb	kg
<b>Suction Elbow</b>	179	81	237	108	232	105
<b>Discharge Pipe Assembly</b>	747	339	747	339	747	339
<b>Control Center</b>	1650	749	1650	749	1650	749
<b>Discharge Pipe Adapter Flange</b>	178	81	178	81	178	81
<b>Optional Isolation Valves</b>	70	32	70	32	115	52
<b>Optional Unit Mounted Pumpout Unit</b>	164	75	164	75	164	75
<b>Vaporizer Oil Sump</b>	700	318	700	318	700	318
<b>Economizer</b>	542	246	542	246	542	246

\*To determine compressor frame size, refer to Fig. 2.

**Table 7 — 23XRV Heat Exchanger Data**

CODE	ENGLISH						SI					
	Dry Rigging Weight (lb)*		Machine Charge				Dry Rigging Weight (kg)*		Machine Charge			
	Cooler Only	Condenser Only	Refrigerant Weight (lb)		Liquid Weight (lb)		Cooler Only	Condenser Only	Refrigerant Weight (kg)		Liquid Weight (kg)	
			With Economizer	Without Economizer	Cooler	Condenser			With Economizer	Without Economizer	Cooler	Condenser
30	4148	3617	800	650	464	464	1877	1676	363	295	210	210
31	4330	3818	800	650	531	542	1959	1769	363	295	241	246
32	4522	4023	800	650	601	621	2046	1860	363	295	273	282
35	4419	4529	910	760	511	513	2000	2089	413	345	232	233
36	4627	4758	910	760	587	602	2094	2195	413	345	266	273
37	4845	4992	910	760	667	692	2193	2299	413	345	303	314
40	5008	4962	900	750	863	915	2675	2746	408	340	391	415
41	5178	5155	900	750	930	995	2758	2839	408	340	422	451
42	5326	5347	900	750	990	1074	2832	2932	408	340	449	487
45	5463	5525	1015	865	938	998	2882	3001	460	392	425	453
46	5659	5747	1015	865	1014	1088	2976	3108	460	392	460	494
47	5830	5967	1015	865	1083	1179	3061	3214	460	392	491	535
50	5827	6013	1250	1100	1101	1225	3182	3304	567	499	499	556
51	6053	6206	1250	1100	1192	1304	3294	3397	567	499	541	591
52	6196	6387	1250	1100	1248	1379	3364	3485	567	499	566	626
55	6370	6708	1430	1280	1201	1339	3429	3620	649	581	545	607
56	6631	6930	1430	1280	1304	1429	3556	3726	649	581	591	648
57	6795	7138	1430	1280	1369	1514	3636	3826	649	581	621	687

\*Rigging weights are for standard tubes of standard wall thickness (Turbo-B3 and Spikefin 2, 0.025-in. [0.635 mm] wall).

NOTES:

1. Cooler includes the suction elbow and 1/2 the distribution piping weight.
2. Condenser includes float valve and sump, discharge stub-out, and 1/2 the distribution piping weight.
3. For special tubes refer to the 23XRV Computer Selection Program.
4. All weights for standard 2-pass NIH (nozzle-in-head) design with victaulic grooves.

**Table 8A — 23XRV Additional Data for Cooler Marine Waterboxes\***

HEAT EXCHANGER FRAME, PASS	ENGLISH			SI		
	Psig	Rigging Weight (lb) (see Note 2)	Water Volume (gal)	kPa	Rigging Weight (kg) (see Note 2)	Water Volume (L)
FRAME 3, 1 AND 3 PASS	150	730	84	1034	331	318
FRAME 3, 2 PASS	150	365	42	1034	166	159
FRAME 4, 1 AND 3 PASS	150	1888	109	1034	856	413
FRAME 4, 2 PASS	150	944	54	1034	428	204
FRAME 5, 1 AND 3 PASS	150	2445	122	1034	1109	462
FRAME 5, 2 PASS	150	1223	61	1034	555	231
FRAME 3, 1 AND 3 PASS	300	860	84	2068	390	318
FRAME 3, 2 PASS	300	430	42	2068	195	159
FRAME 4, 1 AND 3 PASS	300	2162	109	2068	981	413
FRAME 4, 2 PASS	300	1552	47	2068	704	178
FRAME 5, 1 AND 3 PASS	300	2655	122	2068	1204	462
FRAME 5, 2 PASS	300	1965	53	2068	891	201

\*Add to heat exchanger data for total weights or volumes.

NOTES:

1. Weight adder shown is the same for cooler and condenser of equal frame size.
2. For the total weight of a vessel with a marine waterbox, add these values to the heat exchanger weights (or volume).

**Table 8B — 23XRV Additional Data for Condenser Marine Waterboxes\***

HEAT EXCHANGER FRAME, PASS	ENGLISH			SI		
	Psig	Rigging Weight (lb) (see Note 2)	Water Volume (gal)	kPa	Rigging Weight (kg) (see Note 2)	Water Volume (L)
FRAME 3, 1 AND 3 PASS	150	N/A	N/A	1034	N/A	N/A
FRAME 3, 2 PASS	150	365	42	1034	166	159
FRAME 4, 1 AND 3 PASS	150	N/A	N/A	1034	N/A	N/A
FRAME 4, 2 PASS	150	989	54	1034	449	204
FRAME 5, 1 AND 3 PASS	150	N/A	N/A	1034	N/A	N/A
FRAME 5, 2 PASS	150	1195	60	1034	542	227
FRAME 3, 1 AND 3 PASS	300	N/A	N/A	2068	N/A	N/A
FRAME 3, 2 PASS	300	430	42	2068	195	159
FRAME 4, 1 AND 3 PASS	300	N/A	N/A	2068	N/A	N/A
FRAME 4, 2 PASS	300	1641	47	2068	744	178
FRAME 5, 1 AND 3 PASS	300	N/A	N/A	2068	N/A	N/A
FRAME 5, 2 PASS	300	1909	50	2068	866	189

\*Add to heat exchanger data for total weights or volumes.

NOTES:

1. Weight adder shown is the same for cooler and condenser of equal frame size.
2. For the total weight of a vessel with a marine waterbox, add these values to the heat exchanger weights (or volume).

**Table 9A — 23XRV Waterbox Cover Weights — English (lb)**

WATERBOX DESCRIPTION	COOLER						CONDENSER					
	Frame 3		Frame 4		Frame 5		Frame 3		Frame 4		Frame 5	
	Victaulic Nozzles	Flanged	Victaulic Nozzles	Flanged	Victaulic Nozzles	Flanged	Victaulic Nozzles	Flanged	Victaulic Nozzles	Flanged	Victaulic Nozzles	Flanged
NIH,1 pass Cover 150 PSIG	282	318	148	185	168	229	282	318	148	185	168	229
NIH,2 pass Cover 150 PSIG	287	340	202	256	222	276	287	340	191	245	224	298
NIH,3 pass Cover 150 PSIG	294	310	472	488	617	634	294	310	503	519	628	655
NIH Plain End, 150 PSIG	243	243	138	138	154	154	225	225	138	138	154	154
MWB End Cover, 150 PSIG*	243/315	243/315	138/314	138/314	154/390	154/390	225/234	225/234	138/314	138/314	154/390	154/390
NIH,1 pass Cover 300 PSIG	411	486	633	709	764	840	411	486	633	709	764	840
NIH,2 pass Cover 300 PSIG	411	518	626	733	760	867	411	578	622	729	727	878
NIH,3 pass Cover 300 PSIG	433	468	660	694	795	830	433	468	655	689	785	838
NIH Plain End, 300 PSIG	291	291	522	522	658	658	270	270	522	522	658	658
MWB End Cover, 300 PSIG*	445/619	445/619	522/522	522/522	658/658	658/658	359/474	359/474	522/522	522/522	658/658	658/658

\*Rows with two entries list nozzle end and return end weights.

**Table 9B — 23XRV Waterbox Cover Weights — SI (kg)**

WATERBOX DESCRIPTION	COOLER						CONDENSER					
	Frame 3		Frame 4		Frame 5		Frame 3		Frame 4		Frame 5	
	Victaulic Nozzles	Flanged	Victaulic Nozzles	Flanged	Victaulic Nozzles	Flanged	Victaulic Nozzles	Flanged	Victaulic Nozzles	Flanged	Victaulic Nozzles	Flanged
NIH,1 pass Cover 150 PSIG	128	144	67	84	76	104	128	144	67	84	76	104
NIH,2 pass Cover 150 PSIG	130	154	92	116	101	125	130	154	87	111	102	135
NIH,3 pass Cover 150 PSIG	133	141	214	221	280	288	133	141	228	235	285	297
NIH Plain End, 150 PSIG	110	110	63	63	70	70	102	102	63	63	70	70
MWB End Cover, 150 PSIG	110/143	110/143	63/142	63/142	70/177	70/177	102/106	102/106	63/142	63/142	70/177	70/177
NIH,1 pass Cover 300 PSIG	186	220	287	322	347	381	186	220	287	322	346	381
NIH,2 pass Cover 300 PSIG	186	235	284	332	344	393	186	235	282	331	330	398
NIH,3 pass Cover 300 PSIG	196	212	299	315	361	376	196	212	297	313	356	380
NIH Plain End, 300 PSIG	132	132	237	237	298	298	122	122	237	237	298	298
MWB End Cover, 300 PSIG	202/281	202/281	237/237	237/237	298/298	298/298	163/215	163/215	237/237	237/237	298/298	298/298

LEGEND

- NIH — Nozzle-in-Head
- MWB — Marine Waterbox

\*Rows with two entries list nozzle end and return end weights.

NOTE: Weight for NIH 2-pass cover, 150 psig (1034 kPa), is included in the heat exchanger weights shown in Table 7.

RIG MACHINE COMPONENTS — Refer to Fig. 10-26 and Carrier Certified Prints for machine component disassembly.

IMPORTANT: Only a qualified service technician should perform this operation.

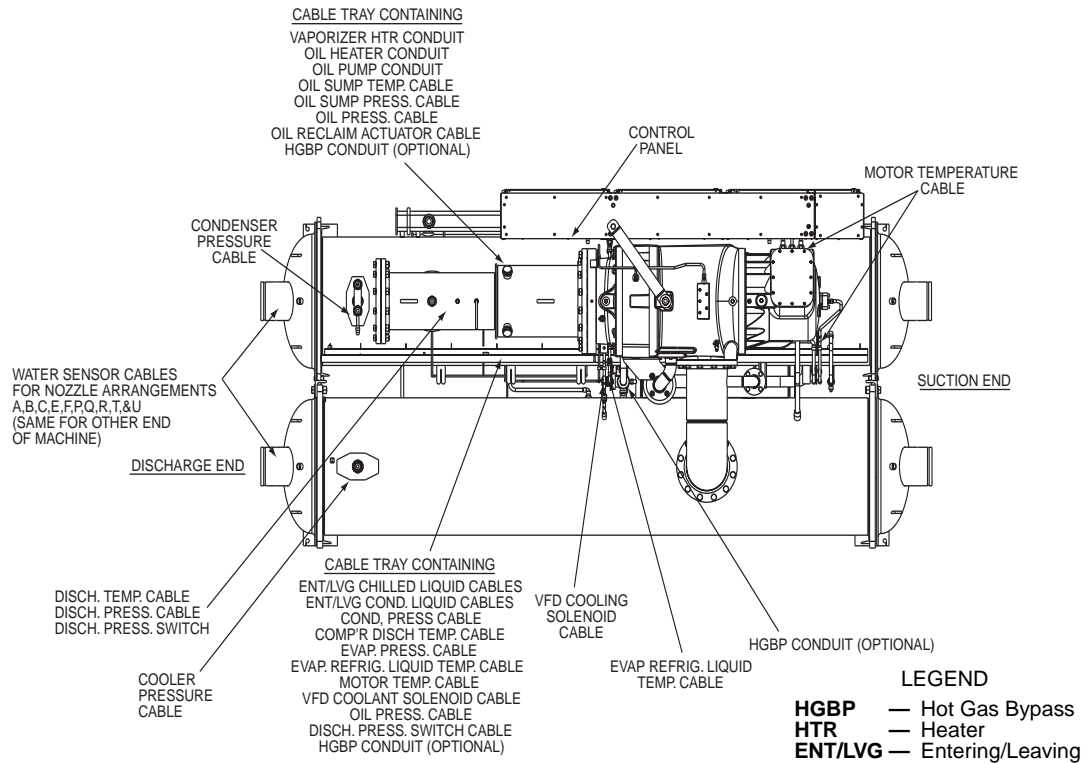
**⚠ WARNING**

Do not attempt to disconnect flanges while the machine is under pressure. Failure to relieve pressure can result in personal injury or damage to the unit.

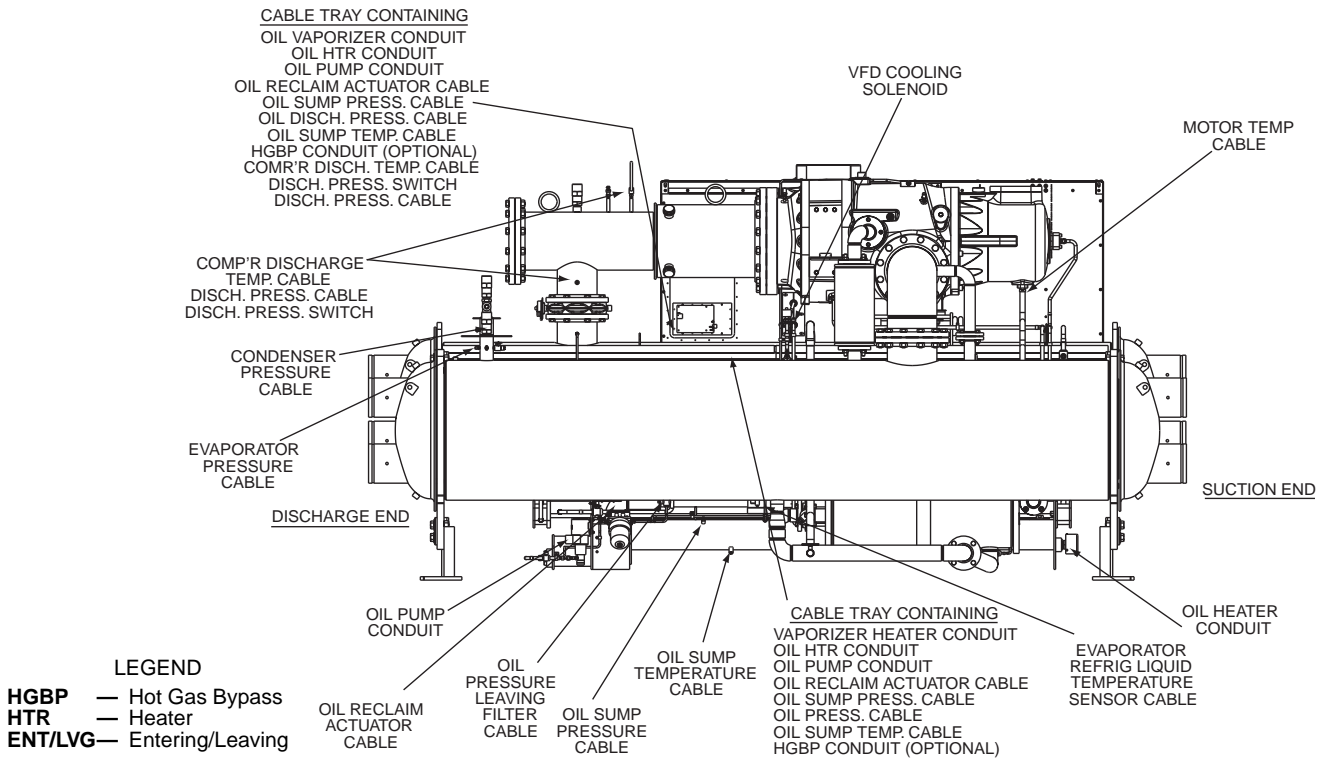
**⚠ CAUTION**

Before rigging the compressor remove control panel and control center.

NOTE: Label each wire before removal when wiring must be disconnected (see Fig. 10 and 11). Clip all wire ties necessary when removing pressure and temperature sensors. Disconnect all pressure transducer wires at the sensor. Temperature sensors cannot be disconnected from their cables; remove temperature sensors from their thermowells and label as required.



**Fig. 10 — Electrical Cable Routing (Top View)**



**Fig. 11 — Electrical Cable Routing (Back View)**

**Separate Machine Components** — The design of the 23XRV allows for disassembly at the job site so that individual components may be moved through existing doorways. Use the following procedures to separate the machine components.

Suggested locations to cut piping will minimize the width of the condenser/economizer assembly.

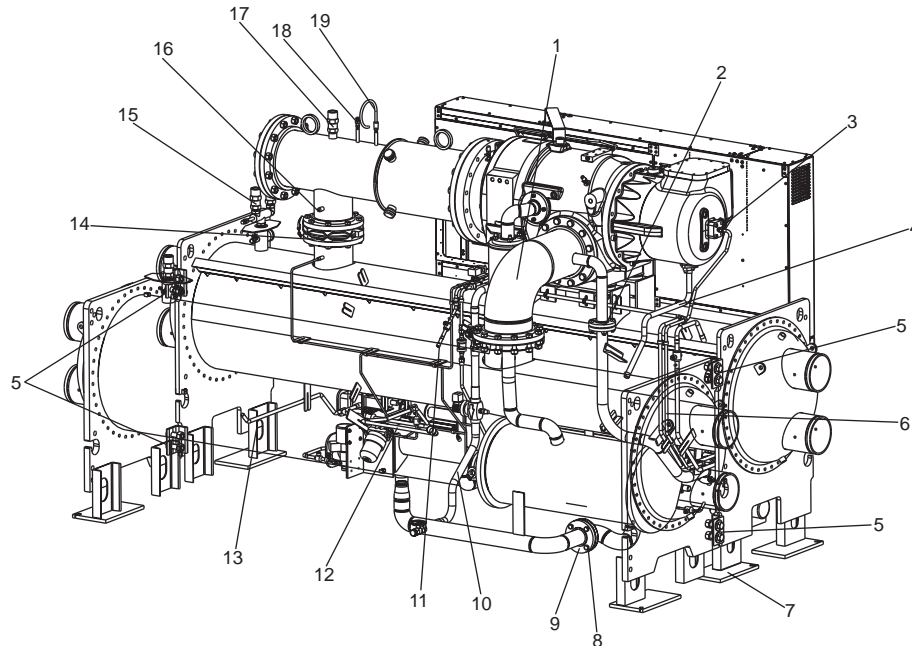
**SEPARATE COOLER AND CONDENSER**

**IMPORTANT:** If the cooler and condenser vessels must be separated, the heat exchangers should be kept level by placing a support plate under the tube sheets. The support plate will also help to keep the vessels level and aligned when the vessels are bolted back together.

**NOTE:** For steps 1 through 13 refer to Fig. 12. The cooler has been removed from the picture to show the pipes and lines that must be cut.

Check that the holding charge has been removed from the chiller.

1. Place a support plate under each tube sheet to keep each vessel level.
2. Remove cooler relief valve and relief valve vent piping.
3. Cut the motor cooling refrigerant drain line.
4. Rig the suction elbow and disconnect the compressor suction line at the cooler and compressor. Remove bolts from the vaporizer vent line flange.
5. Cut the VFD cooling drain line.
6. Cut the oil reclaim line(s).
7. Cut the hot gas bypass line between the HGBP (hot gas bypass) solenoid valve and the cooler feed line.
8. Unbolt the cooler liquid feed line near the economizer or condenser float chamber at the flanged connection. Temporarily secure the in-line economizer orifice plate (economized chillers only) to the economizer flange (see Fig. 12).

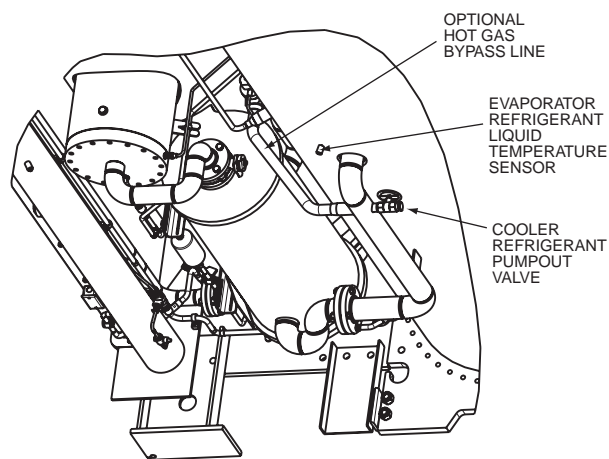


- |                                      |   |
|--------------------------------------|---|
| 1 — Suction Elbow (Unbolt)           | 11 — VFD Cooling Drain Line                         |
| 2 — Vaporizer Vent Line (Unbolt)     | 12 — Oil Reclaim Line (Cut)                         |
| 3 — Motor Cooling Line (Unbolt)      | 13 — Vaporizer Hot Gas Return Line (Cut)            |
| 4 — Motor Cooling Drain Line (Cut)   | 14 — Discharge Isolation Valve (Optional)           |
| 5 — Tubesheet Mounting Bracket       | 15 — Condenser Relief Valves (Unscrew)              |
| 6 — Bearing Oil Drain Line           | 16 — Discharge Temperature Sensor                   |
| 7 — Support Plate                    | 17 — Discharge Pipe Assembly Relief Valve (Unscrew) |
| 8 — In-Line Economizer Orifice Plate | 18 — Discharge Pressure Sensor                      |
| 9 — Cooler Liquid Feed Line (Unbolt) | 19 — Discharge Pressure Switch                      |
| 10 — Hot Gas Bypass Line (Cut)       |   |

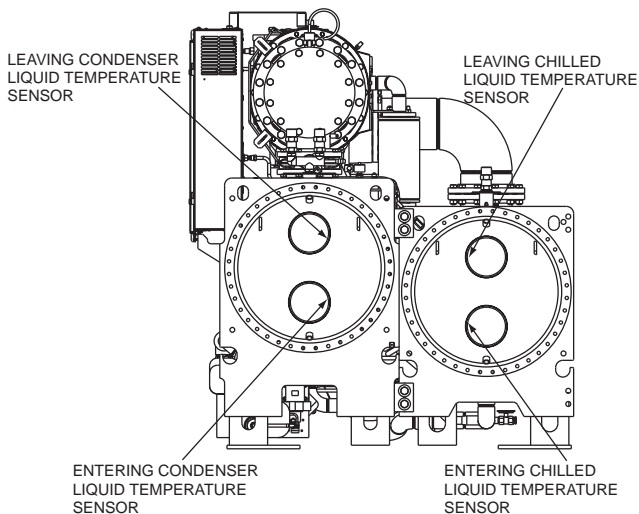
**Fig. 12 — Cooler/Discharge Pipe Assembly Removal**

9. Cut the vaporizer refrigerant return line as shown.
10. Disconnect all sensors with cables that cross from the condenser side of the machine to the cooler side including:
  - a. Evaporator refrigerant liquid temperature sensor. See Fig. 13.
  - b. Entering and leaving chiller liquid temperature sensors. See Fig. 14.
  - c. Evaporator pressure sensor.
11. Disconnect the tubesheet mounting brackets from the vessel connectors on the tube cooler tubesheet.
12. Cover all openings.
13. Rig the cooler away from the condenser/compressor.

NOTE: To reassemble, follow steps in reverse order. Connect sensors and cables after major components have been secured to reduce the risk damaging them.



**Fig. 13 — Evaporator Refrigerant Liquid Temperature Sensor on Bottom of Cooler**



**Fig. 14 — Chiller End View**

**⚠ CAUTION**

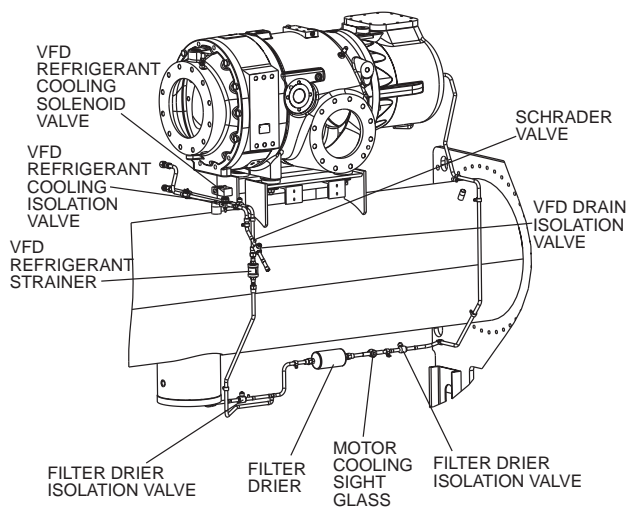
Do not rig the condenser before the control center and compressor are removed. The condenser/compressor assembly has a high center of gravity and may tip over when lifted at the tubesheet rigging points, which could result in equipment damage and/or serious personal injury.

REMOVE THE CONTROLS/DRIVE ENCLOSURE FROM THE CONDENSER — Confirm that the power supply disconnect is open and all safety procedures are observed before removing the VFD. This procedure minimizes the number of sensors and cables that need to be disconnected.

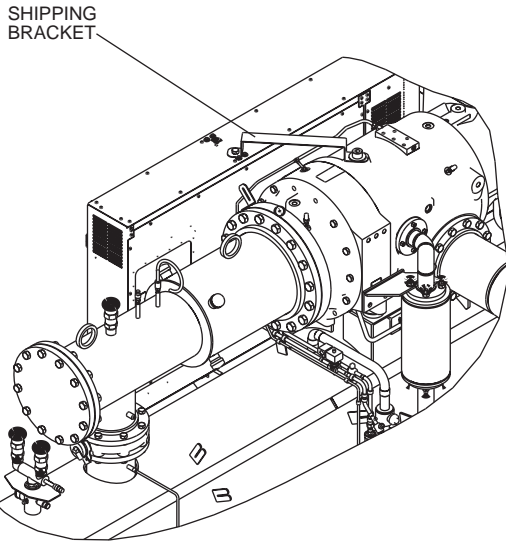
**⚠ WARNING**

Do not attempt to remove the VFD without first isolating the refrigerant charge in the condenser. Damage to one of the motor terminals during VFD removal will result in an uncontrolled refrigerant leak.

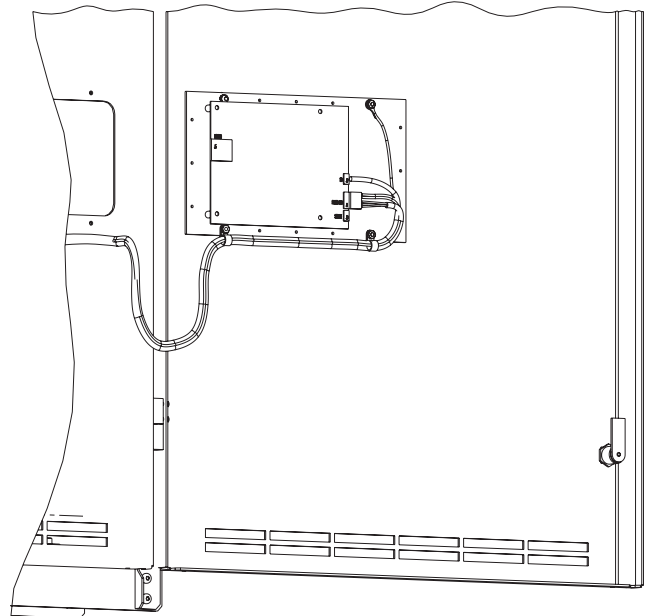
1. Close the 2 filter drier isolation valves (Fig. 15) and the 2 VFD isolation valves. Isolate the refrigerant charge into the condenser to prevent a refrigerant leak if one of the motor terminals is accidentally damaged during VFD removal or installation. Evacuate the VFD coldplate through the Schrader valve (Fig. 15) on the VFD drain isolation valve.
2. Remove the shipping bracket between the VFD and the compressor if it is still in place. Remove any conduits that bring power to the VFD. See Fig. 16.



**Fig. 15 — VFD Refrigerant Isolation Valves**

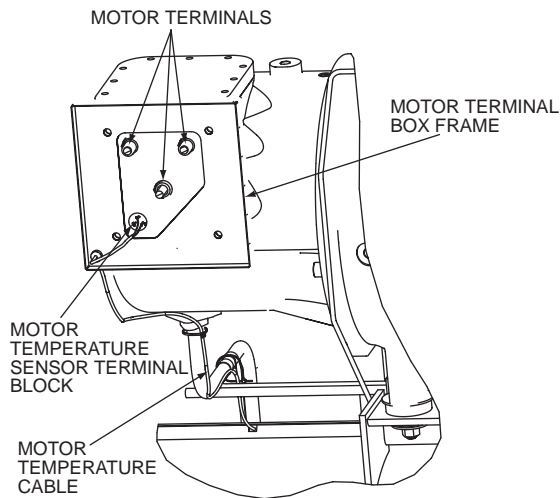


**Fig. 16 — VFD Shipping Bracket**

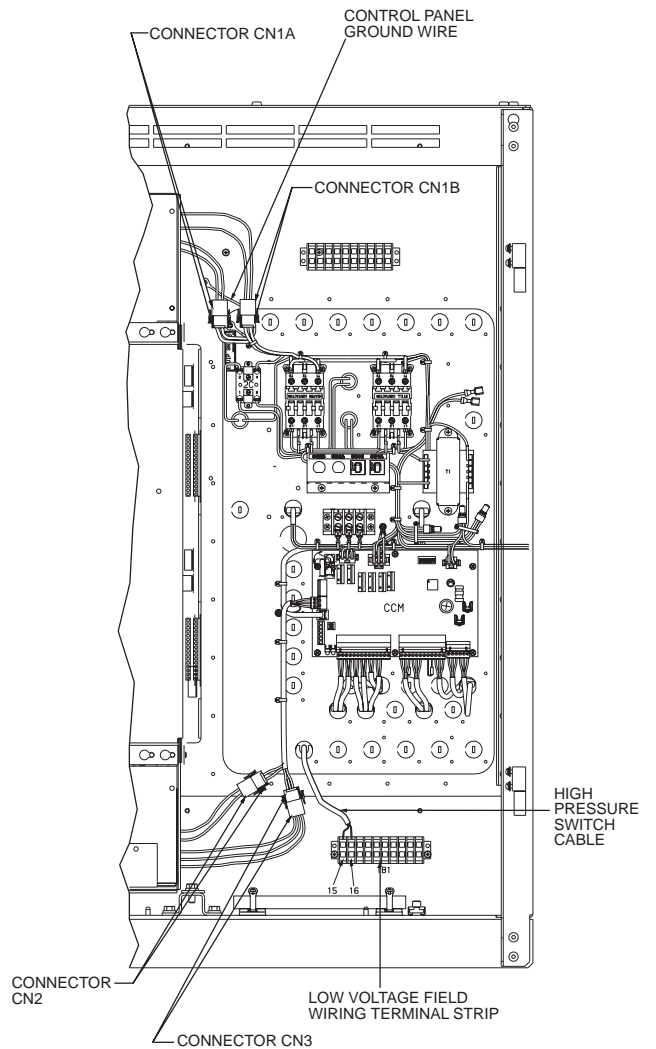


**Fig. 18 — ICVC Communication Cables**

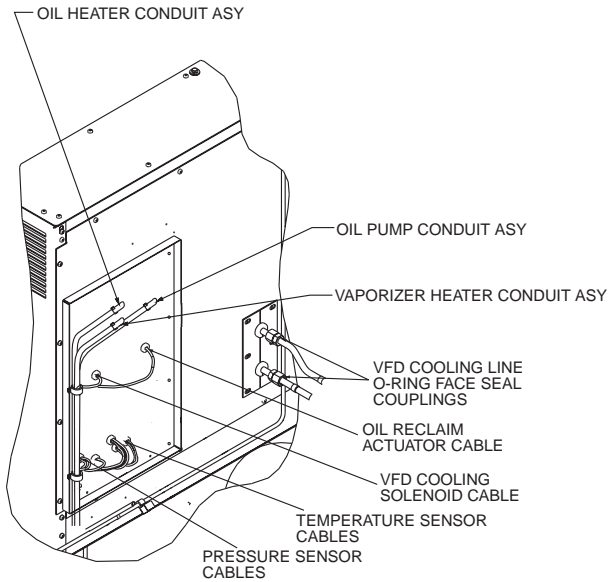
3. Remove the nuts that secure the terminal box transition piece to the motor housing.
4. Disconnect the motor leads from the motor terminals (Fig. 17). Note the position of the motor terminal cable lugs so they can be reinstalled with sufficient clearance away from surrounding structure.
5. Remove the motor temperature sensor leads (Fig. 17), the motor ground lead, and the bolts that secure the VFD enclosure to the terminal box transition piece.
6. Disconnect the communication cables from the back of the ICVC (Fig. 18).
7. Disconnect the high pressure switch leads from terminal strip TB1, terminals 15 and 16 (Fig. 19).
8. Unplug connectors CN1A, CN1B, CN2, and CN3 (Fig. 19).
9. Disconnect the control panel ground wire (Fig. 19) that is located next to connectors CN1A and CN1B.
10. Disconnect the VFD cooling lines (Fig. 20) and cover all openings.
11. Remove the 12 screws that secure the control panel to the VFD enclosure. Tilt the control panel away from the back of the control center.
12. Position the control panel on top of the condenser and secure it in place to prevent damage.



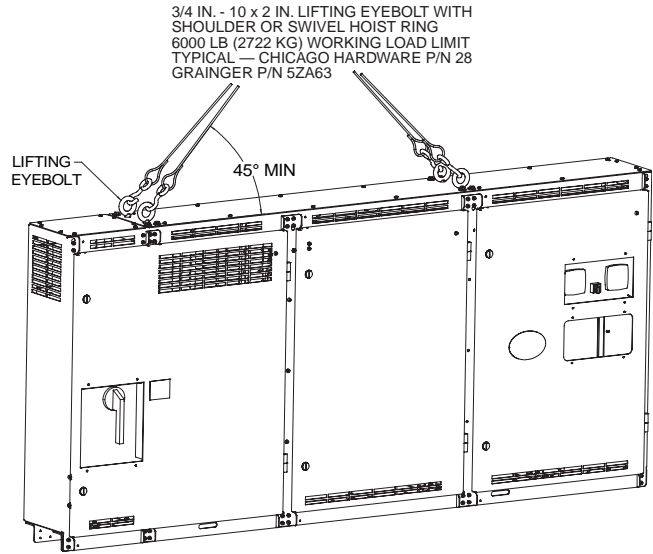
**Fig. 17 — Motor Terminals**



**Fig. 19 — Control Panel Connectors**



**Fig. 20 — Control Panel Back**



**Fig. 21 — Control Center Lifting Points**

**Lifting the Control Center** — Care should be used to prevent damage due to dropping or jolting when moving the control center. A fork truck or similar means of lifting and transporting may be used. Sling in a manner that will equalize the load at the pickup points. Use a spreader bar if the angle of the sling is less than 45 degrees relative to horizontal. Do not jolt while lifting.

Use the following procedure to lift the control center.

1. Remove the rubber hole plugs in the top of the control center and fully thread in 4 eyebolts or swivel hoist rings (see Fig. 21). Lifting hardware must have 3/4 in.-10 x 2 in. long threads and must have a working load limit of at least 6000 lb (2722 kg). Typical eyebolts are Chicago Hardware (size 28) or Grainger (P/N 5ZA63).
2. Attach a sling to the four lifting eyebolts. Make certain that the angle of the sling is not less than 45 degrees relative to horizontal.
3. Using an overhead or portable hoist (minimum 2 ton rated capacity), attach a free-fall chain to the sling secured to the drive. Take up any slack in the chain.
4. Rig the control center and remove the bolts that secure it to the VFD mounting brackets on the condenser (see Fig. 21).
5. Confirm that welding procedures comply with local Pressure Vessel Codes before removing a portion of the VFD support bracket from the condenser. Custom brackets should be fabricated if part of the VFD supports must be cut off of the condenser to reduce the width of the condenser assembly. Clamp 1/4-in. plates over both sides of the VFD bracket and drill two pairs of holes that

straddle the line along which the VFD brackets will be cut. This will allow the VFD brackets to be reinstalled and welded in their original position.

NOTE: To reassemble, follow steps in reverse order. Connect sensors and cables after major components have been secured to reduce the risk damaging them. (See Fig. 22.)

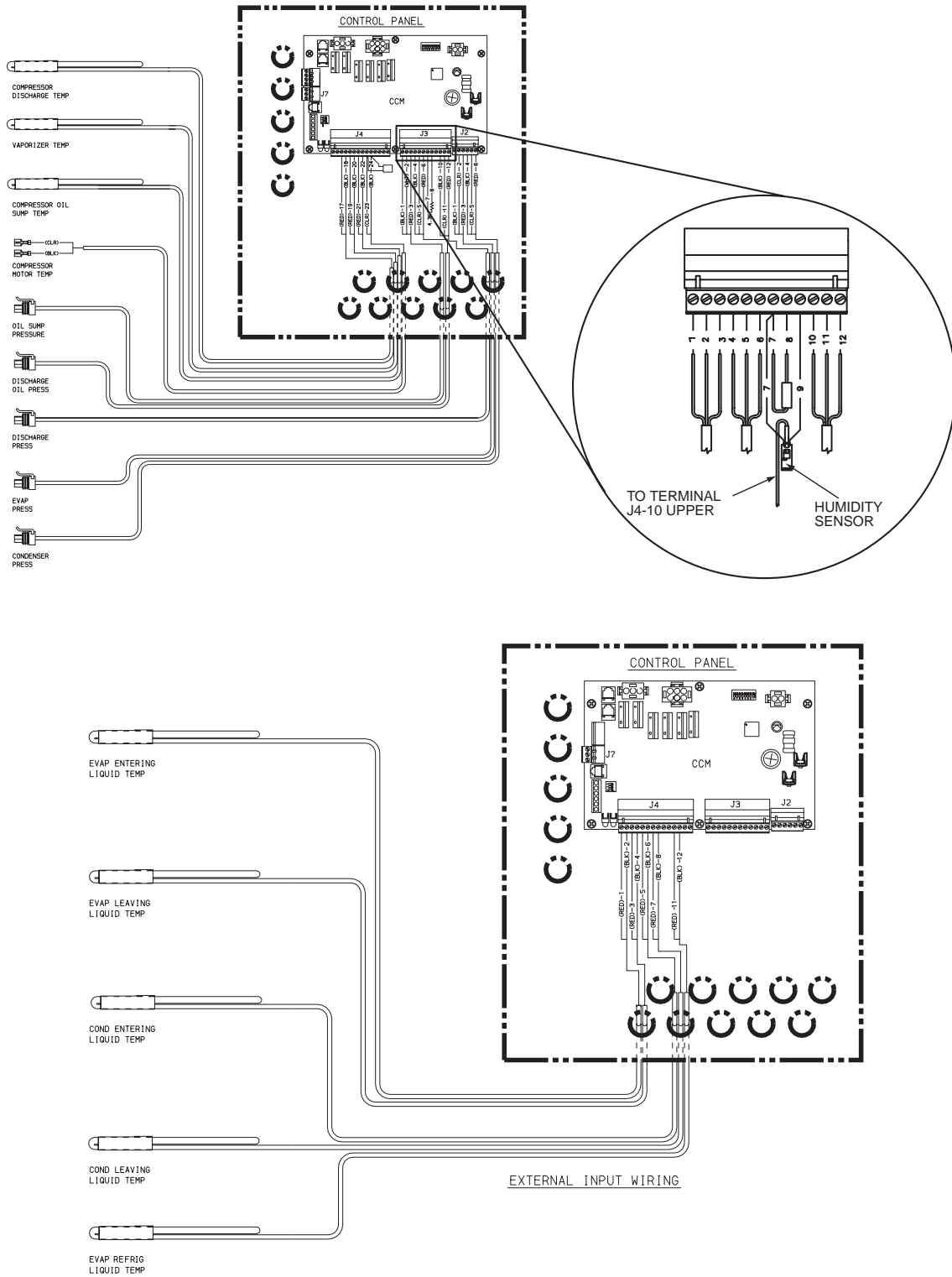
**REMOVE THE DISCHARGE PIPE ASSEMBLY FROM THE CONDENSER**

NOTE: For steps 1 through 6 refer to Fig. 12.

The condenser relief valve and relief valve vent piping should be removed if they will interfere with discharge pipe assembly rigging.

1. Remove the discharge pipe assembly relief valve and relief valve vent piping.
2. Disconnect the compressor discharge temperature sensor.
3. Disconnect the compressor discharge pressure sensor and remove the high discharge pressure switch sensor.
4. Rig the discharge pipe assembly and remove the bolts from the compressor discharge and condenser inlet flange. Note the position and orientation of the discharge isolation valve on the condenser inlet flange.
5. Remove the discharge pipe assembly.
6. Cover all openings.

NOTE: To reassemble, follow steps in reverse order. Connect sensors and cables after major components have been secured to reduce the risk of damaging them.



**Fig. 22 — Control Panel Inputs**

SEPARATE THE COMPRESSOR FROM THE CONDENSER

**⚠ CAUTION**

Do not rig the condenser before the control center and compressor are removed. The condenser/compressor assembly has a high center of gravity and may tip over when lifted at the tubesheet rigging points, which could result in equipment damage and/or serious personal injury.

The VFD blocks access to the compressor mounting bolts. It must be removed before the compressor can be separated from the condenser. See instructions to remove the VFD from the condenser. Refer to Table 10.

**Table 10 — Compressor Fastener Identification**

COMPRESSOR FASTENERS	SIZE
Discharge Pipe Assembly to Compressor Discharge Flange	1 in.-8 Grade 5 Hex Head
Suction Elbow to Compressor Inlet	7/8 in.-9 Grade 5 Hex Head
Compressor Mount to Condenser Economizer Line	3/4 in.-10 Studs (A-449)
Motor Cooling, Motor Drain, Oil Drain	5/8 in.-11 Grade 8 Hex Head
Compressor Lifting Points (2)	M30x3.5 Threaded Holes
Stator Housing Lifting Point	M30x3.5 Threaded Hole
Discharge Housing Lifting Point	M30x3.5 Threaded Hole

1. Disconnect the oil supply line in two places (Fig. 23). Cap the oil lines and fittings.

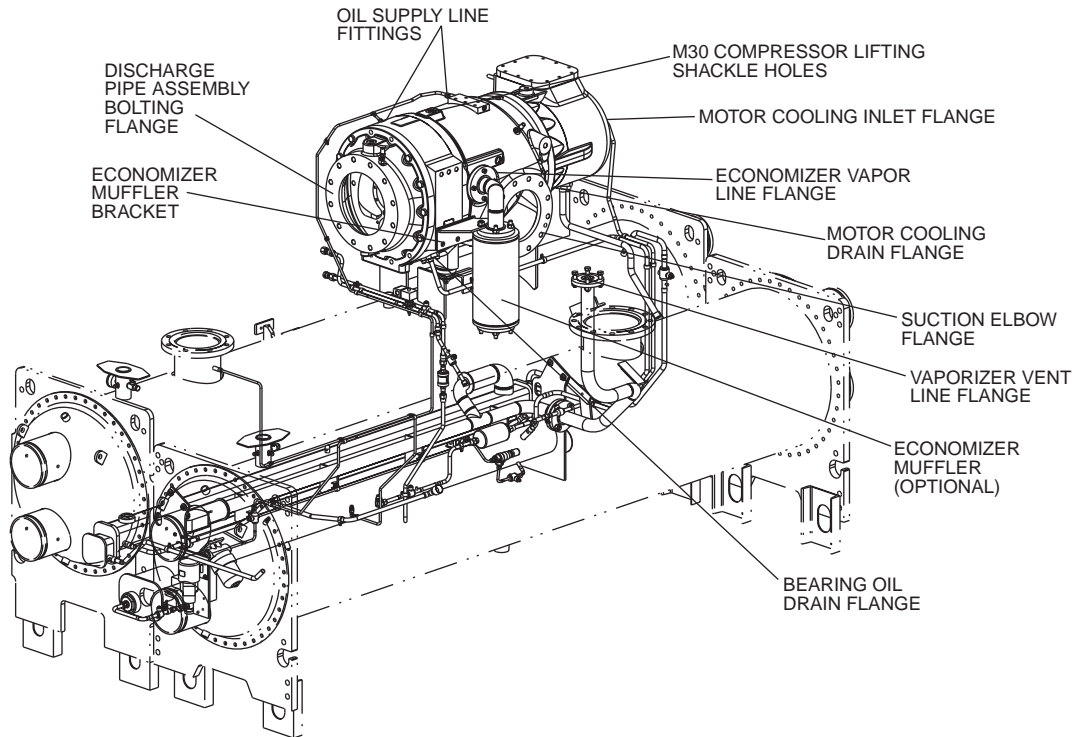
NOTE: Compressor oil lines and fittings between the oil filter and compressor must be kept extremely clean to prevent obstruction of the compressor inlet bearing oil orifice. Cap all orifice lines and fittings during disassembly. The compressor inlet bearing oil orifice is located at the lubrication block on top of the compressor.

2. Disconnect the motor cooling inlet flange, the motor cooling drain flange, optional economizer vapor line flange, and bearing oil drain flange (Fig. 23). Remove the economizer muffler bracket.
3. Brace the end of the discharge pipe assembly closest to the compressor if it has not already been removed. Place an oil pan under the compressor flange to collect oil that may have accumulated in the discharge pipe assembly. Unbolt

the discharge pipe assembly from the compressor. It may also be necessary to loosen the bolts that attach the discharge pipe assembly to the condenser.

4. If the cooler has been removed, rig the suction elbow and unbolt the suction elbow at the compressor and vaporizer vent line flanges (see Fig. 12). If the cooler is still in place, it may be necessary to loosen the bolts that secure the suction elbow to the cooler.
5. Carefully remove the perforated insulation cutouts that cover the compressor lifting points. See Fig. 23. Replace the lifting shackle thread protector after the compressor is re-installed to prevent insulation adhesive from fouling the threads.
6. Rig the compressor with lifting eyelets installed in the two M30 threaded holes provided in the top of the compressor housing (Fig. 23). Use only M30 forged eye bolts or M30 hoist rings with a sufficient working load limit to safely lift the compressor. The rubber vibration isolators may pull out of the compressor mounting bracket when the compressor is lifted off of the condenser. Applying leak detection soap solution to the outside of the vibration isolators will make it easier to press the isolators back into position.
7. Cover all openings.

NOTE: To reassemble, follow steps in reverse order. Connect sensors and cables after major components have been secure to reduce the risk damaging them.



**Fig. 23 — Compressor Removal**

SEPARATE THE VAPORIZER FROM THE CONDENSER — The VFD mounting brackets (Fig. 24) extend beyond the outboard edge of the vaporizer. The vaporizer extends beyond the perimeter of the condenser tubesheet.

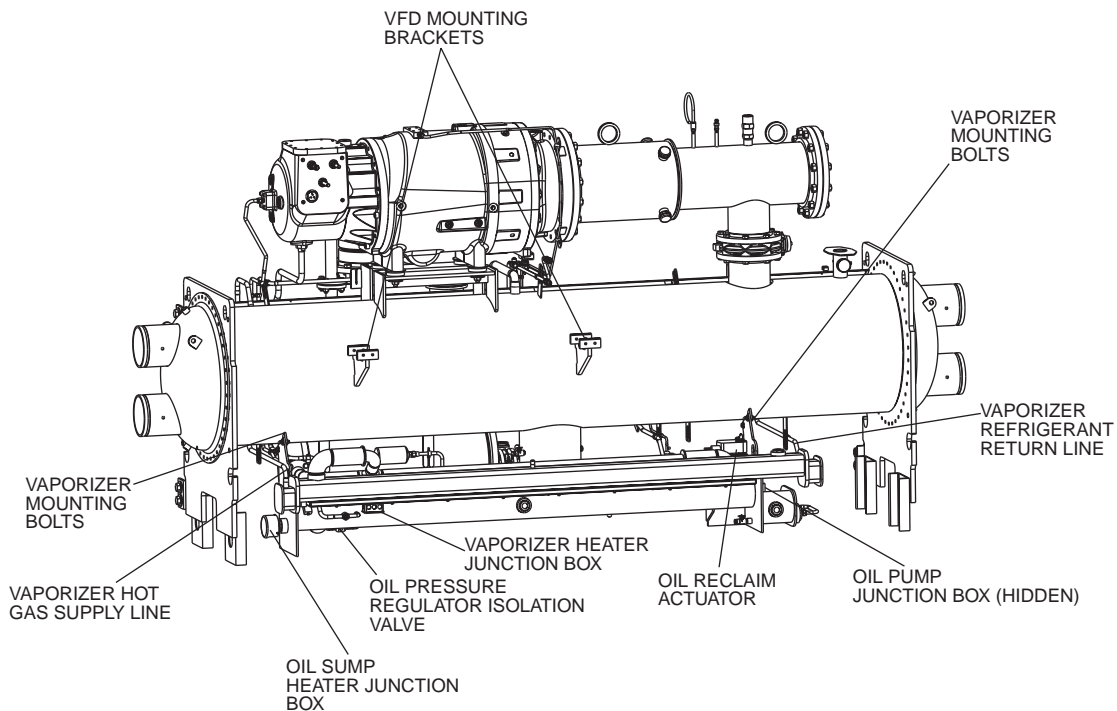
1. Cut the vaporizer hot gas supply line near the oil concentrator (Fig. 24).
2. Cut the vaporizer hot gas return line (Fig. 24).
3. Cut the bearing oil drain line near the oil sump (Fig. 25).
4. Unbolt the vaporizer vent line flange shown in Fig. 25.
5. Cut the oil supply line as shown in Fig. 25.
6. Cut the oil reclaim line as shown in Fig. 25.
7. Disconnect all wires and cable leads to the vaporizer assembly (see Fig 26) including:
  - a. oil sump temperature sensor
  - b. oil sump pressure cable and oil pressure leaving filter cable
  - c. oil reclaim cable
  - d. vaporizer heater cable in the vaporizer heater junction box
  - e. oil pump cable
  - f. oil sump heater conduit (Fig. 24)
  - g. vaporizer temperature sensor
8. Rig the vaporizer with the lifting points on the vaporizer mounting bracket and remove the four bolts that secure it to the condenser (Fig. 24).
9. Cover all openings.

NOTE: To reassemble, follow steps in reverse order. Connect sensors and cables after major components have been secured to reduce the risk damaging them.

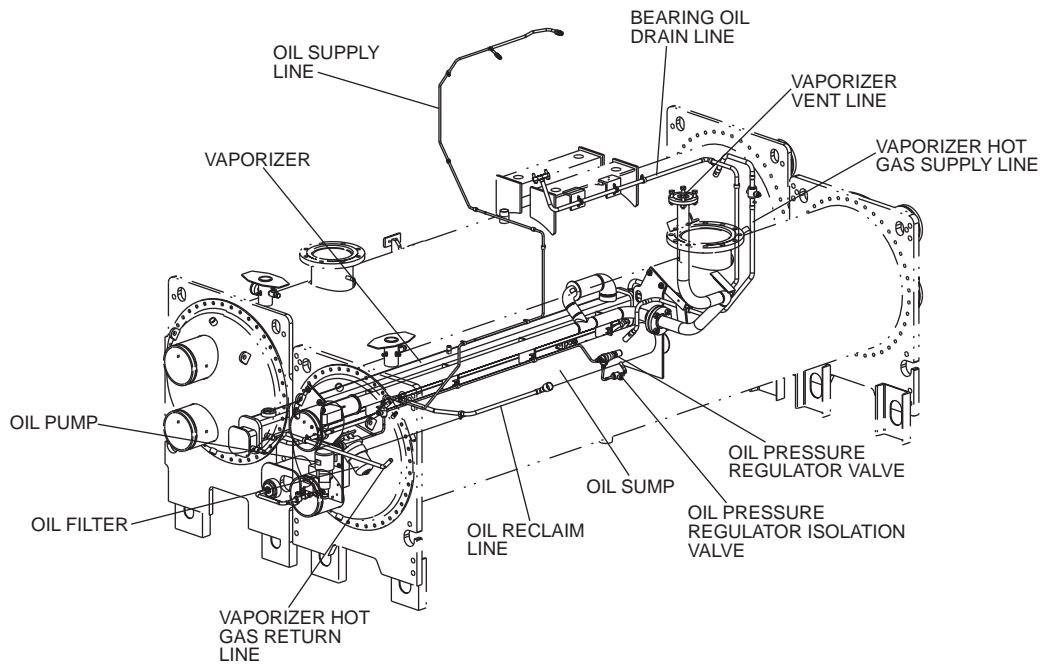
### VFD Installation

1. Install terminal box frame mounting studs into tapped holes using short threaded end (see section E-E in Fig. 27). Do not exceed 120 ft-lb (163 N-m).
2. Install thermal insulators, insulation frame assembly, and terminal box frame prior to attaching motor power cables.
3. Torque motor terminals to 45 to 55 ft-lb (61 to 75 N-m).
4. There may be 1 or 2 motor power cables per terminal identified as T1, T2 and T3. Position motor end lugs on terminal studs with Belleville washer located against the front terminal lug with the convex side facing toward the front terminal nut. Clinch the two cables together with wire ties before tightening terminal nuts. Install front terminal nut finger tight. Hold front terminal nut stationary while tightening rear terminal nut to 45 to 50 ft-lb (61 to 68 N-m). (See Fig. 28.)
5. Check all terminal connections for proper installation.

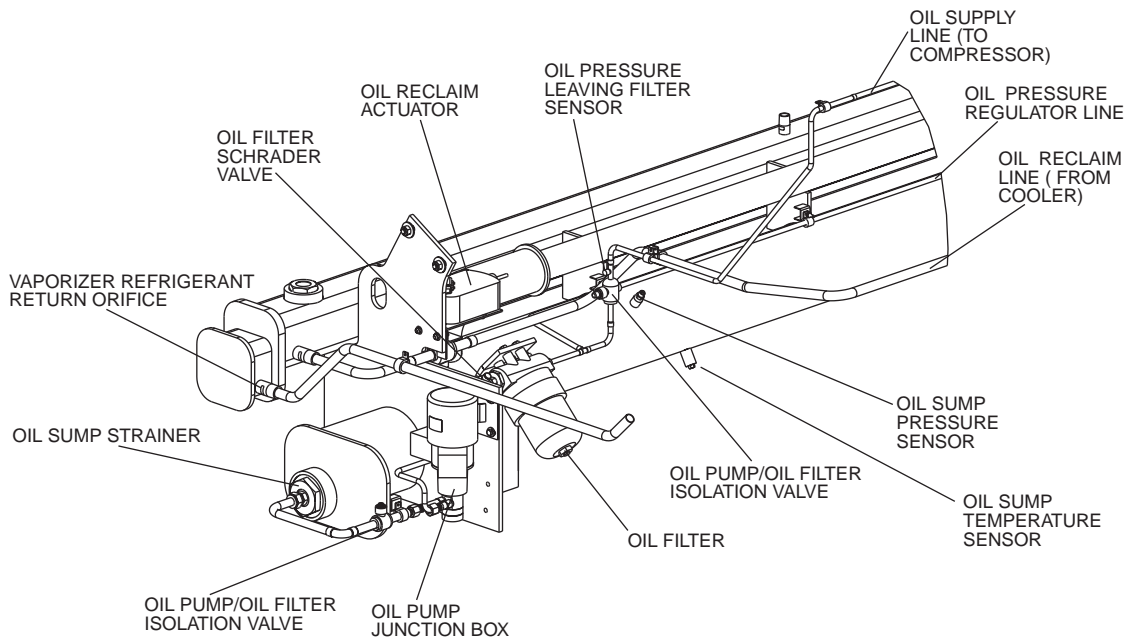
**IMPORTANT:** Do not insulate terminals until wiring arrangement has been checked and approved by Carrier start-up personnel. Motor terminals must be insulated in acceptance with national and local electrical codes.



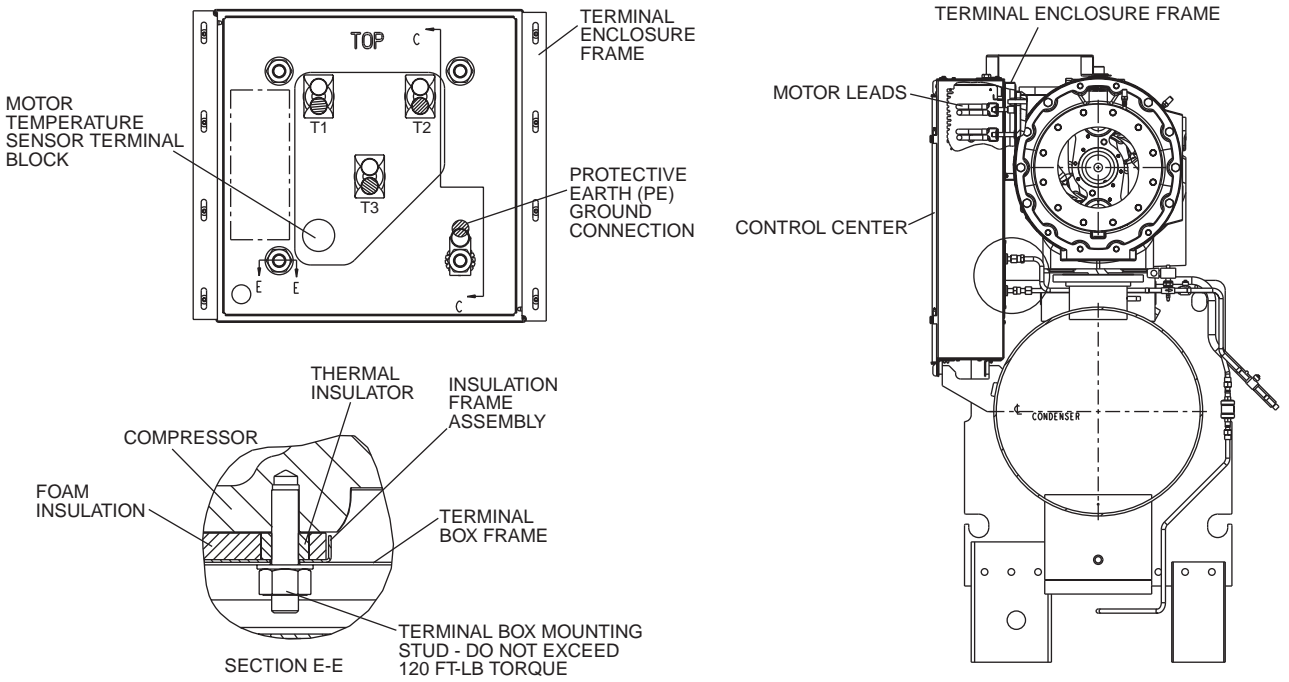
**Fig. 24 — Oil Concentrator Removal**



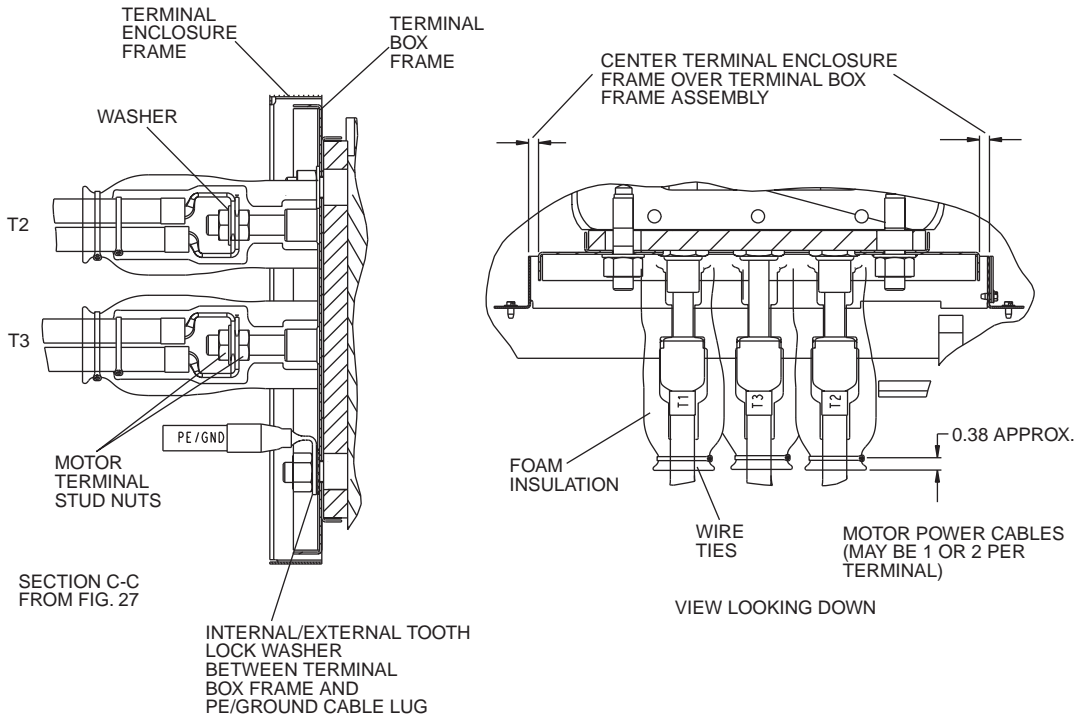
**Fig. 25 — Oil Reclaim Piping**



**Fig. 26 — Oil Reclaim Components**



**Fig. 27 — Motor Terminal Box**



**Fig. 28 — Motor Terminal Insulation**

**Insulate Motor Terminals and Lead Wire Ends** — Locate heat shrink tubing (RCD P/N LF33MM114) over power connections so that they are completely covered and tubing is against motor housing. Shrink into position. Slide foam tubing (3 in. inner diameter closed cell vinyl, neoprene, or nitrile foam) part way over the heat shrink tubing. Apply adhesive for closed cell foam insulation to motor side end of the foam tubing and push tubing the rest of the way over the terminal and against the sheet insulation on the motor side. Secure the opposite end of the foam tubing with a wire tie as shown in Fig. 28.

**Alternate Insulation for Motor Terminals and Lead Wire Ends** — Insulate compressor motor terminals, lead wire ends, and electrical wires to prevent moisture condensation and electrical arcing. Obtain Carrier approved insulation material from RCD (Replacement Components Division) consisting of 3 rolls of insulation putty and one roll of vinyl tape.

- a. Insulate each terminal by wrapping with one layer of insulation putty (RCD P/N 19EA411-1102).
  - b. Overwrap putty with 4 layers of vinyl tape.
6. Orient PE/ground lug as shown in Fig. 28. Assemble internal/external tooth lock washer between the terminal box frame and the PE/ground cable. Torque PE/ground lug nut to 55 to 65 ft-lb (75 to 89 N-m). See section H-H in Fig. 29 for PE/ground cable routing.
  7. Center terminal enclosure frame over terminal box frame assembly so the space between the frames is equal within

$\frac{3}{16}$ -in. (5 mm) at the top and bottom. Use the slots in the terminal enclosure frame. Adjust spacing between the sides of the terminal enclosure frame and terminal box frame assemblies by moving the control center to the left or right.

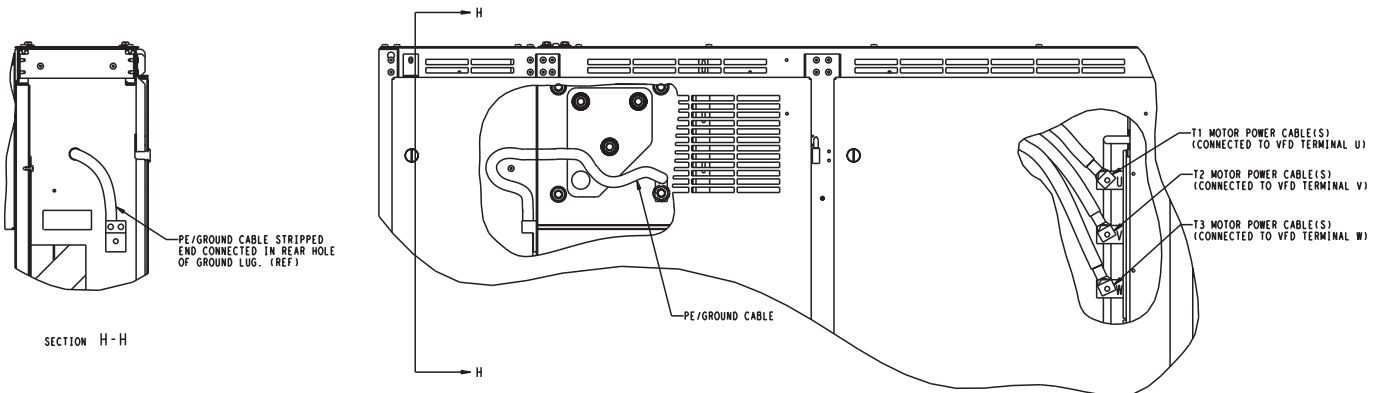
8. Install O-rings on VFD refrigerant connections using silicone grease. Tighten connector using two wrenches to 27 to 33 ft-lb (37 to 45 N-m). (See Detail A in Fig. 30.)
9. Evacuate all piping between the VFD and the VFD isolation valves after assembly and tightening of VFD fittings. Dehydration/evacuation is complete to equalize VFD piping pressure with machine pressure if machine is charged with refrigerant (see Fig. 30).

### Install Machine Supports

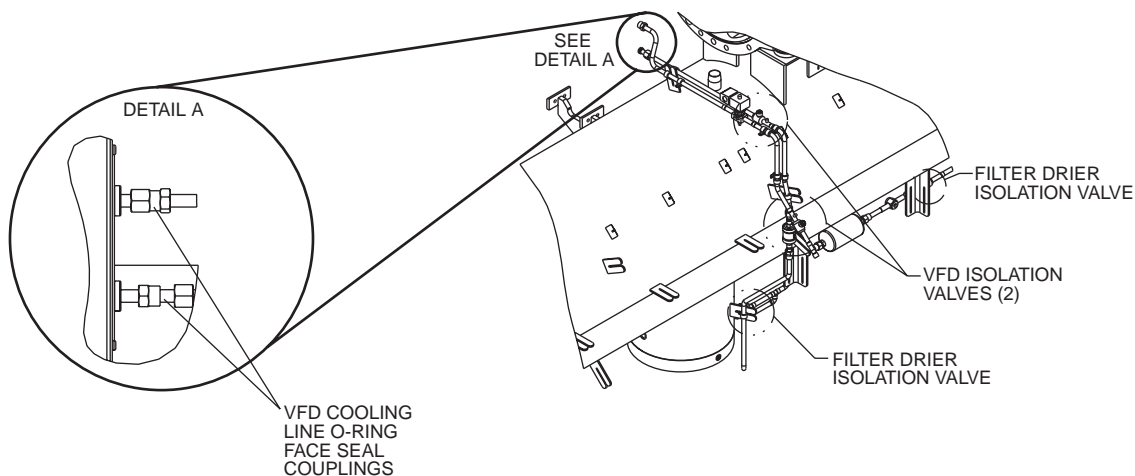
**IMPORTANT:** Chiller housekeeping pad, anchor bolts and attachment points to be designed by others in accordance with all applicable national and local codes.

**INSTALL STANDARD ISOLATION** — Figures 31 and 32 show the position of support plates and shear flex pads, which together form the standard machine support system.

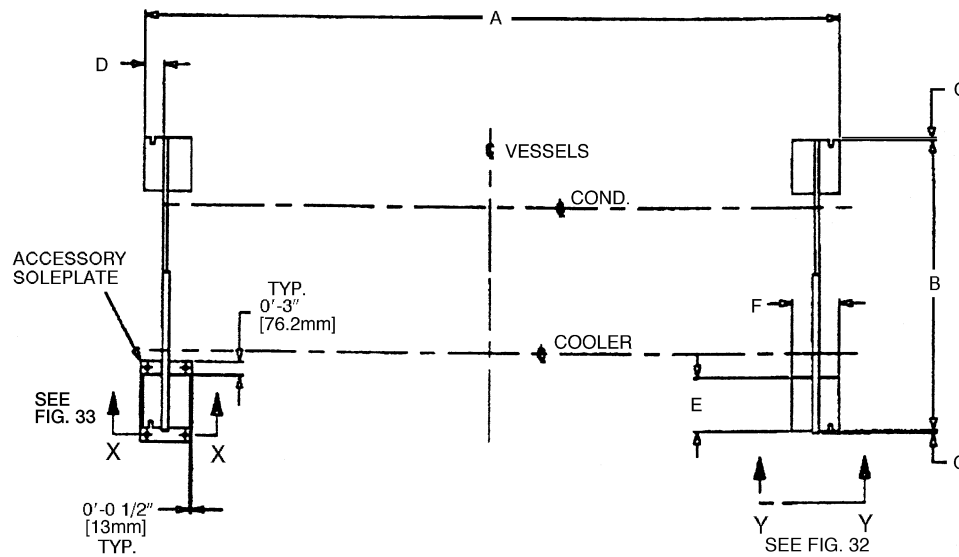
Service clearance under the chiller can be enhanced if the grout is not extended along the entire length of the heat exchangers.



**Fig. 29 — Motor Ground Cable**

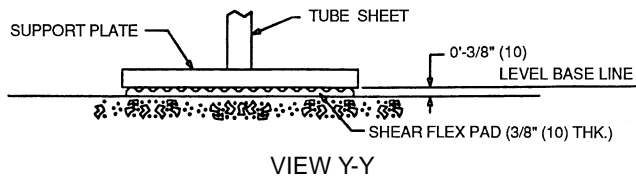


**Fig. 30 — VFD Refrigerant Connectors**



23XRV HEAT EXCHANGER SIZE	DIMENSIONS (ft.-in.)						
	A	B	C	D	E	F	G
30-32	12-10 <sup>3</sup> / <sub>4</sub>	5-5 <sup>1</sup> / <sub>4</sub>	0	0-3 <sup>5</sup> / <sub>8</sub>	1-3 <sup>1</sup> / <sub>4</sub>	0-9	0-1 <sup>1</sup> / <sub>2</sub>
35-37	14- 7 <sup>1</sup> / <sub>4</sub>	5-5 <sup>1</sup> / <sub>4</sub>	0	0-3 <sup>5</sup> / <sub>8</sub>	1-3 <sup>1</sup> / <sub>4</sub>	0-9	0-1 <sup>1</sup> / <sub>2</sub>
40-42	12-10 <sup>3</sup> / <sub>4</sub>	6-0	0-1 <sup>1</sup> / <sub>2</sub>	0-3 <sup>5</sup> / <sub>8</sub>	1-3 <sup>1</sup> / <sub>4</sub>	0-9	0-1 <sup>1</sup> / <sub>2</sub>
45-47	14- 7 <sup>1</sup> / <sub>4</sub>	6-0	0-1 <sup>1</sup> / <sub>2</sub>	0-3 <sup>5</sup> / <sub>8</sub>	1-3 <sup>1</sup> / <sub>4</sub>	0-9	0-1 <sup>1</sup> / <sub>2</sub>
50-52	12-10 <sup>3</sup> / <sub>4</sub>	6-5 <sup>1</sup> / <sub>2</sub>	0-1 <sup>1</sup> / <sub>2</sub>	0-3 <sup>5</sup> / <sub>8</sub>	1-3 <sup>1</sup> / <sub>4</sub>	0-9	0-1 <sup>1</sup> / <sub>2</sub>
55-57	14- 7 <sup>1</sup> / <sub>4</sub>	6-5 <sup>1</sup> / <sub>2</sub>	0-1 <sup>1</sup> / <sub>2</sub>	0-3 <sup>5</sup> / <sub>8</sub>	1-3 <sup>1</sup> / <sub>4</sub>	0-9	0-1 <sup>1</sup> / <sub>2</sub>

Fig. 31 — 23XRV Machine Footprint



NOTES:

1. Dimensions in ( ) are in millimeters.
2. Isolation package includes 4 shear flex pads.

Fig. 32 — Standard Isolation

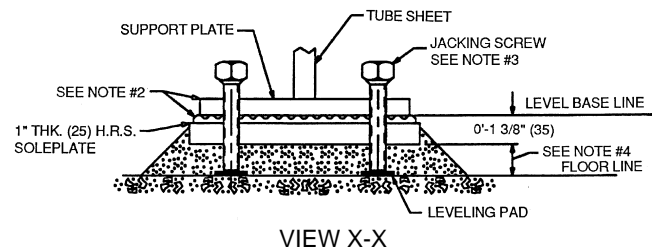
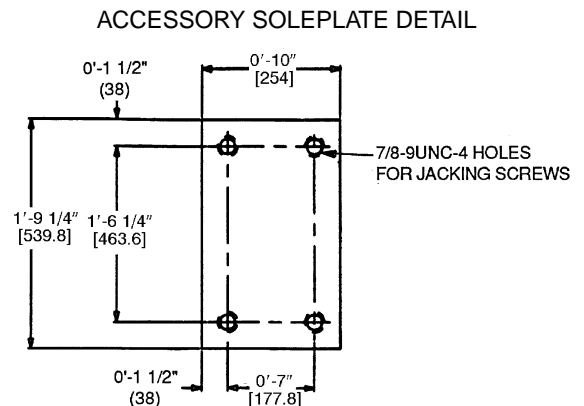
INSTALL ACCESSORY ISOLATION (if required) — Uneven floors or other considerations may dictate the use of accessory soleplates (supplied by Carrier for field installation) and leveling pads. Refer to Fig. 33.

Level machine by using jacking screws in isolation soleplates. Use a level at least 24-in. (610 mm) long.

**IMPORTANT:** Chiller support plates must be level within 1/2 in. from one end to the other end of the heat exchangers for effective oil reclaim system operation.

For adequate and long lasting machine support, proper grout selection and placement is essential. Carrier recommends that only pre-mixed, epoxy type, non-shrinking grout be used for machine installation. Follow manufacturer's instructions in applying grout.

1. Check machine location prints for required grout thickness.
2. Carefully wax jacking screws for easy removal from grout.
3. Grout must extend above the base of the soleplate and there must be no voids in grout beneath the plates.
4. Allow grout to set and harden, per manufacturer's instructions, before starting machine.



LEGEND

HRS — Hot Rolled Steel

NOTES:

1. Dimensions in ( ) are in millimeters.
2. Accessory (Carrier supplied, field installed) soleplate package includes 4 soleplates, 16 jacking screws and leveling pads.
3. Jacking screws to be removed after grout has set.
4. Thickness of grout will vary, depending on the amount necessary to level chiller. Use only pre-mixed non-shrinking grout, Ceilcote 748 OR Chemrex Embeco 636 Plus Grout 0'-1 1/2" (38.1) to 0'-2 1/4" (57) thick.

Fig. 33 — Accessory Isolation

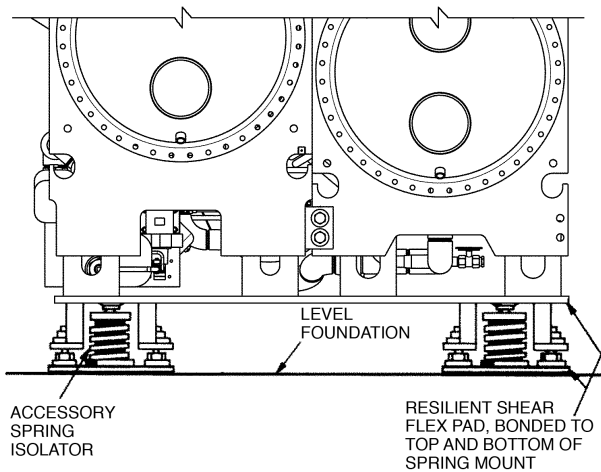
- Remove jacking screws from leveling pads after grout has hardened.

## INSTALL SPRING ISOLATION

**IMPORTANT:** Accessory spring isolation packages are intended solely for non-seismic applications. Seismic applications must be designed by a registered professional in accordance with all applicable national and local codes.

Spring isolation may be purchased as an accessory from Carrier for field installation. It may also be field supplied and installed. Spring isolators may be placed directly under machine support plates or located under machine soleplates. See Fig. 34. Consult job data for specific arrangement. Low profile spring isolation assemblies can be field supplied to keep the machine at a convenient working height.

Obtain specific details on spring mounting and machine weight distribution from job data. Also, check job data for methods to support and isolate pipes that are attached to spring isolated machines.



NOTE: The accessory spring isolators are supplied by Carrier for installation in the field.

**Fig. 34 — 23XRV Accessory Spring Isolation (Shown with Accessory Soleplates)**

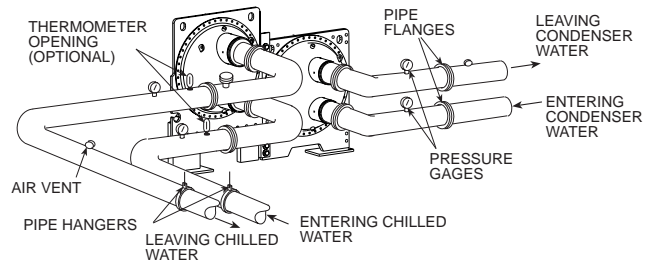
## Connect Piping

**IMPORTANT:** Chiller water nozzle connections to be designed by others in accordance with all applicable national and local codes.

### CAUTION

Remove cooler and condenser liquid temperature and optional pressure sensors before welding connecting piping to water nozzles. Refer to Fig. 15. Replace sensors after welding is complete.

**INSTALL WATER PIPING TO HEAT EXCHANGERS** — Refer to Table 4 for nozzle sizes. Install piping using job data, piping drawings, and procedures outlined below. A typical piping installation is shown in Fig. 35.



**Fig. 35 — Typical Nozzle Piping**

### CAUTION

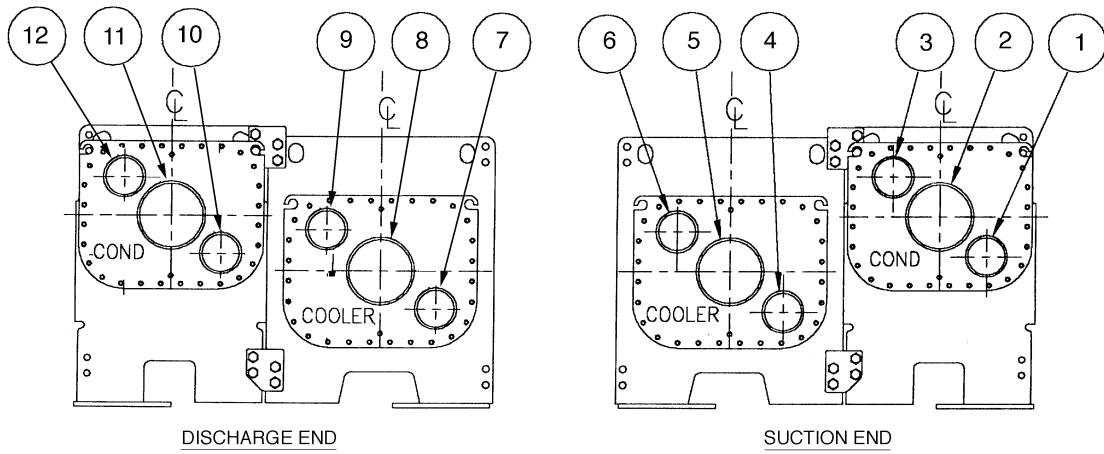
Factory-supplied insulation is not flammable but can be damaged by welding sparks and open flame. Protect insulation with a wet canvas cover.

- Offset pipe flanges to permit removal of waterbox cover for maintenance and to provide clearance for pipe cleaning. No flanges are necessary with marine waterbox option; however, water piping should not cross in front of the waterbox cover or access will be blocked.
- Provide openings in water piping for required pressure gages and thermometers. For thorough mixing and temperature stabilization, wells in the leaving water pipe should extend inside pipe at least 2 in. (51 mm).
- Install air vents at all high points in piping to remove air and prevent water hammer.
- Install pipe hangers where needed. Make sure no weight or stress is placed on waterbox nozzles or flanges.
- Water flow direction must be as specified in Fig. 36 and 37.  
NOTE: Entering water is always the lower of the 2 nozzles. Leaving water is always the upper nozzle for cooler or condenser.
- Install waterbox vent and drain piping in accordance with individual job data. All connections are  $3/4$ -in. FPT.
- Install waterbox drain plugs in the unused waterbox drains and vent openings.
- Install optional pumpout system or pumpout system and storage tank as shown in Fig. 38-42.

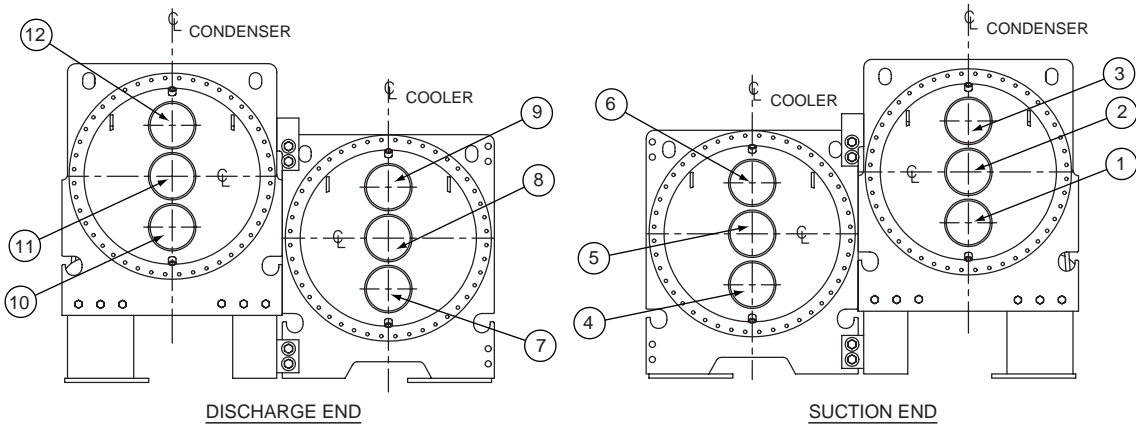
### CAUTION

Never charge liquid 134a refrigerant into the chiller if the pressure is less than 35 psig (241 kPa). Charge as a gas only, with the cooler and condenser pumps running, until 35 psig (241 kPa) is reached using a pumpdown. Terminate the pumpdown mode using the ICVC. Flashing of liquid refrigerant at low pressures can cause tube freeze-up and considerable damage.

### NOZZLE-IN HEAD WATERBOXES



**FRAME 3**



**FRAMES 4 AND 5**

### NOZZLE ARRANGEMENT CODES FOR ALL 23XRV NOZZLE-IN-HEAD WATERBOXES

PASS	COOLER WATERBOXES		
	In	Out	Arrangement Code*
1	8	5	A
	5	8	B
2	7	9	C
	4	6	D
3	7	6	E
	4	9	F

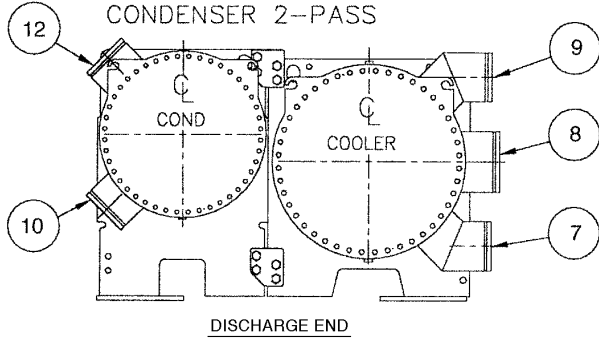
PASS	CONDENSER WATERBOXES		
	In	Out	Arrangement Code*
1	11	2	P
	2	11	Q
2	10	12	R
	1	3	S
3	10	3	T
	1	12	U

\*Refer to certified drawings.

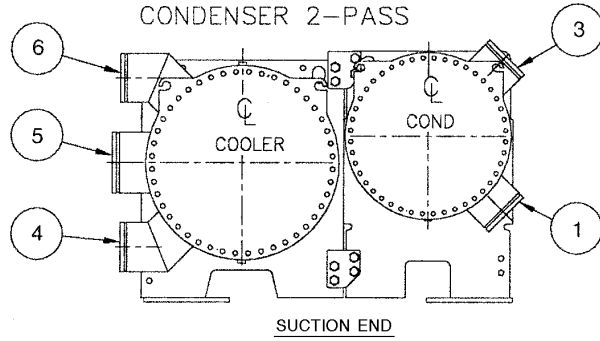
**Fig. 36 — Piping Flow Data (NIH, Frames 3 Through 5)**

**MARINE WATERBOXES**

NOTE :  
COOLER 3-PASS NOZZLE @ 45°  
(NOT SHOWN) SIMILIAR TO  
CONDENSER 2-PASS



NOTE :  
COOLER 3-PASS NOZZLE @ 45°  
(NOT SHOWN) SIMILIAR TO  
CONDENSER 2-PASS

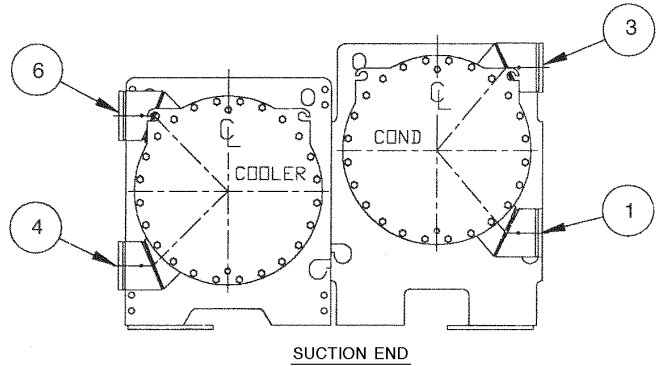
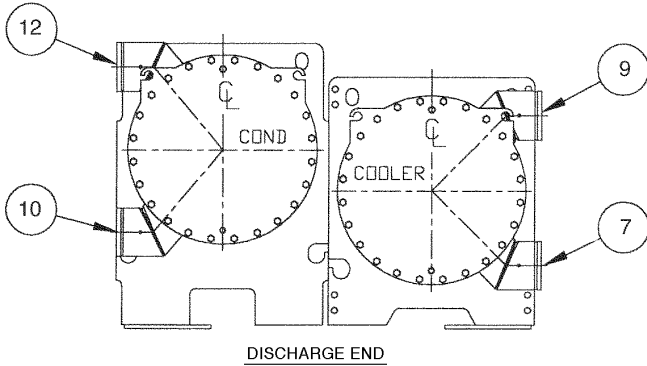


**FRAME 3**

**NOZZLE ARRANGEMENT CODES**

PASS	COOLER WATERBOXES			CONDENSER WATERBOXES		
	In	Out	Arrangement Code	In	Out	Arrangement Code
1	8	5	A	—	—	—
	5	8	B	—	—	—
2	7	9	C	10	12	R
	4	6	D	1	3	S
3	7	6	E	—	—	—
	4	9	F	—	—	—

**MARINE WATERBOXES**

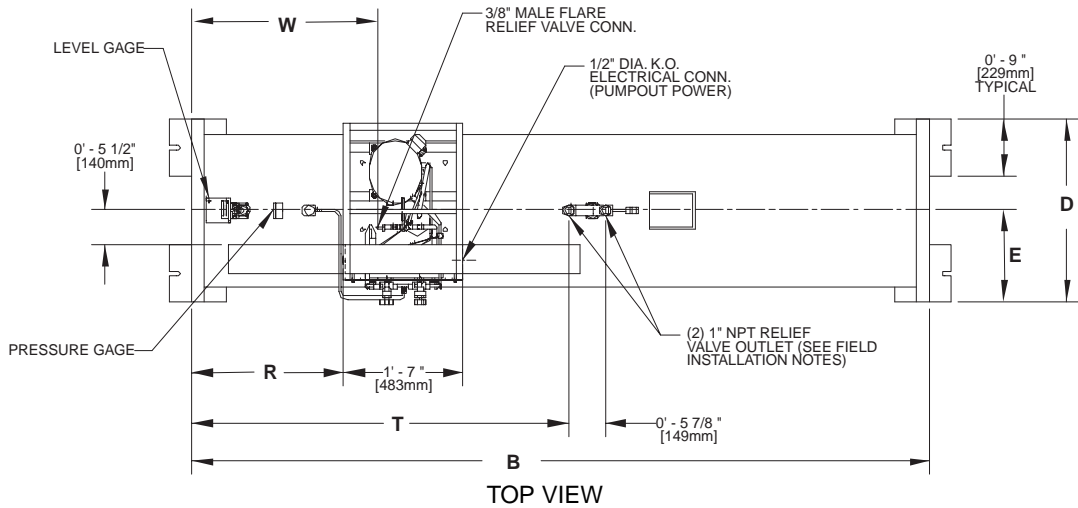


**FRAMES 4 AND 5**

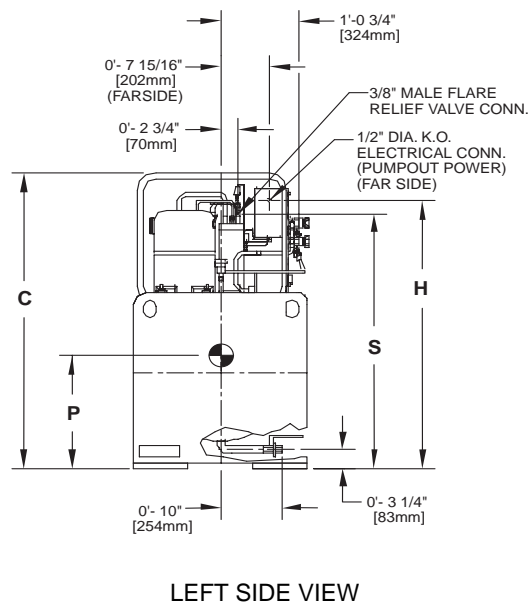
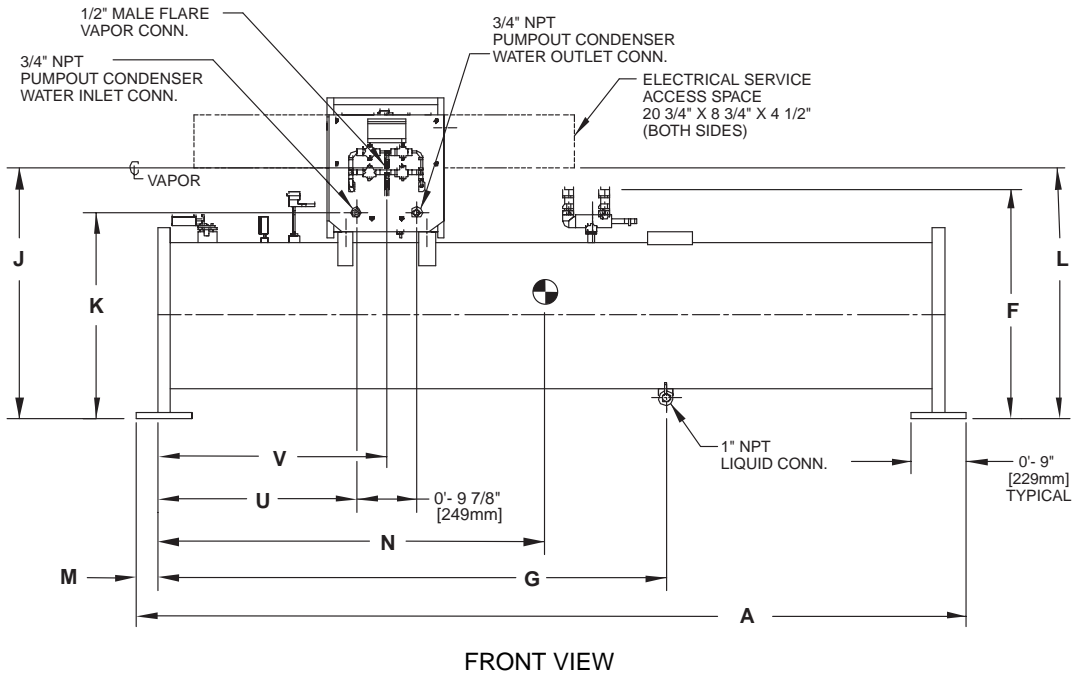
**NOZZLE ARRANGEMENT CODES**

PASS	COOLER WATERBOXES			CONDENSER WATERBOXES		
	In	Out	Arrangement Code	In	Out	Arrangement Code
1	9	6	A	—	—	—
	6	9	B	—	—	—
2	7	9	C	10	12	R
	4	6	D	1	3	S
3	7	6	E	—	—	—
	4	9	F	—	—	—

**Fig. 37 — Piping Flow Data (Marine Waterboxes, Frames 3 Through 5)**



- NOTES:
1. Denotes center of gravity.
  2. Dimensions in [ ] are in millimeters.
  3. The weights and center of gravity values given are for an empty storage tank.
  4. For additional information on the pumpout unit, see certified drawings.
  5. Conduit knockout is located on the side of the control box.
  6. 28 cubic ft storage tank weight: 2334 lb (1059 kg).
  7. 52 cu ft storage tank weight: 3414 lb (1549 kg).



**DIMENSIONS**  
ENGLISH (ft.-in.)

TANK SIZE	A	B	C	D	E	F	G	H	J	K
0428	10- 5	9-10	4-4 <sup>1</sup> / <sub>4</sub>	2-4 <sup>3</sup> / <sub>4</sub>	1-2 <sup>3</sup> / <sub>8</sub>	3-1 <sup>1</sup> / <sub>4</sub>	6-4 <sup>3</sup> / <sub>16</sub>	3-11 <sup>3</sup> / <sub>8</sub>	3-4 <sup>7</sup> / <sub>8</sub>	2-9 <sup>9</sup> / <sub>16</sub>
0452	14-11 <sup>1</sup> / <sub>4</sub>	14- 4 <sup>1</sup> / <sub>2</sub>	4-8 <sup>1</sup> / <sub>4</sub>	2-8 <sup>1</sup> / <sub>2</sub>	1-4 <sup>1</sup> / <sub>4</sub>	3-4 <sup>1</sup> / <sub>2</sub>	7-2 <sup>1</sup> / <sub>4</sub>	4- 3 <sup>1</sup> / <sub>4</sub>	3-8 <sup>3</sup> / <sub>4</sub>	3-1 <sup>7</sup> / <sub>16</sub>

TANK SIZE	L	M	N	P	R	S	T	U	V	W
0428	3-4 <sup>5</sup> / <sub>8</sub>	0-3 <sup>1</sup> / <sub>2</sub>	4- 9 <sup>1</sup> / <sub>2</sub>	1-7 <sup>7</sup> / <sub>8</sub>	2-0 <sup>3</sup> / <sub>8</sub>	3-9	5-0 <sup>1</sup> / <sub>4</sub>	2-5	2-9 <sup>7</sup> / <sub>8</sub>	2-5 <sup>3</sup> / <sub>4</sub>
0452	3-8 <sup>1</sup> / <sub>2</sub>	0-3 <sup>3</sup> / <sub>8</sub>	6-11 <sup>5</sup> / <sub>8</sub>	1-8 <sup>3</sup> / <sub>4</sub>	2-0 <sup>5</sup> / <sub>8</sub>	4-1	5-0 <sup>1</sup> / <sub>2</sub>	2-5 <sup>1</sup> / <sub>4</sub>	2-10 <sup>1</sup> / <sub>8</sub>	2-6

SI (mm)

TANK SIZE	A	B	C	D	E	F	G	H	J	K
0428	3175	2997	1327	730	365	946	1935	1203	1038	852
0452	4553	4381	1429	826	413	1029	2191	1302	1137	951

TANK SIZE	L	M	N	P	R	S	T	U	V	W
0428	1032	89	1451	505	619	1143	1530	737	860	756
0452	1130	86	2124	527	625	1225	1537	742	867	762

**Fig. 38 — Optional Pumpout Unit and Storage Tank**

## RATED DRY WEIGHT AND REFRIGERANT CAPACITY

ENGLISH (lb)

TANK SIZE	TANK OD (in.)	DRY WEIGHT* (lb)	R-134a MAXIMUM REFRIGERANT CAPACITY (lb)	
			ANSI/ASHRAE 15	UL 1963
0428	24.00	2334	1860	1716
0452	27.25	3414	3563	3286

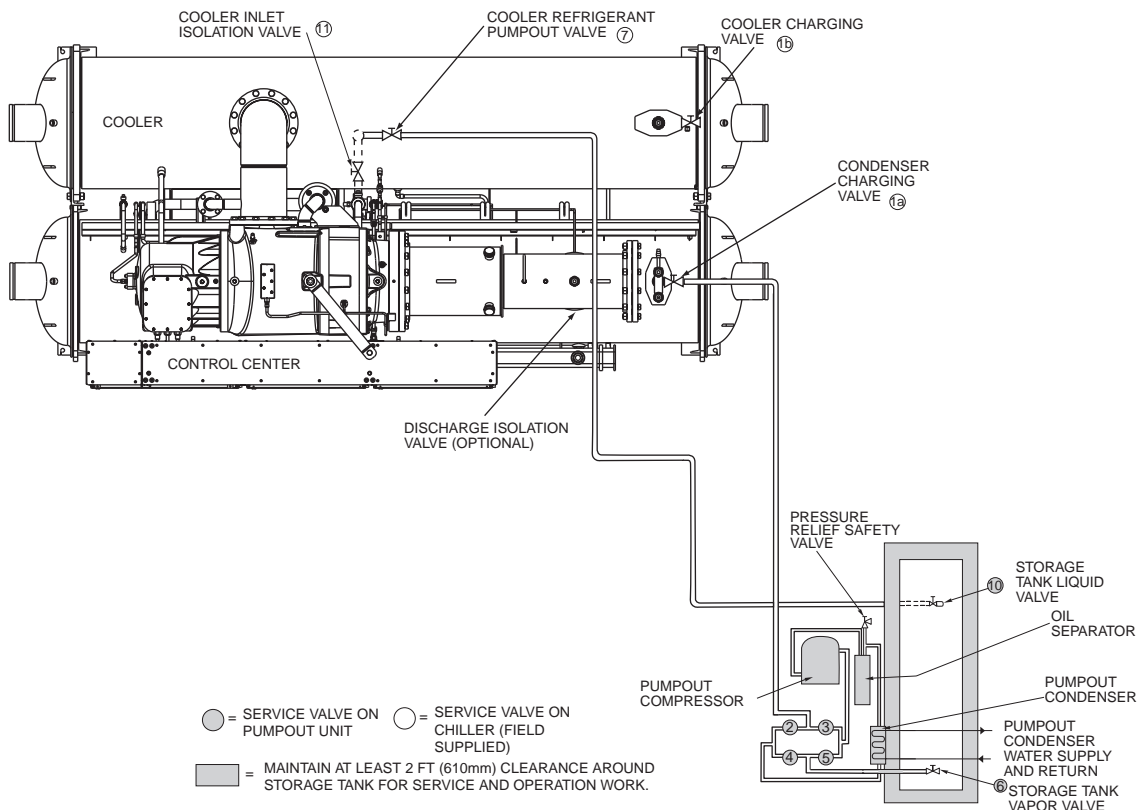
SI (kg)

TANK SIZE	TANK OD (mm)	DRY WEIGHT* (kg)	R-134a MAXIMUM REFRIGERANT CAPACITY (kg)	
			ANSI/ASHRAE 15	UL 1963
0428	610	1059	844	778
0452	692	1549	1616	1491

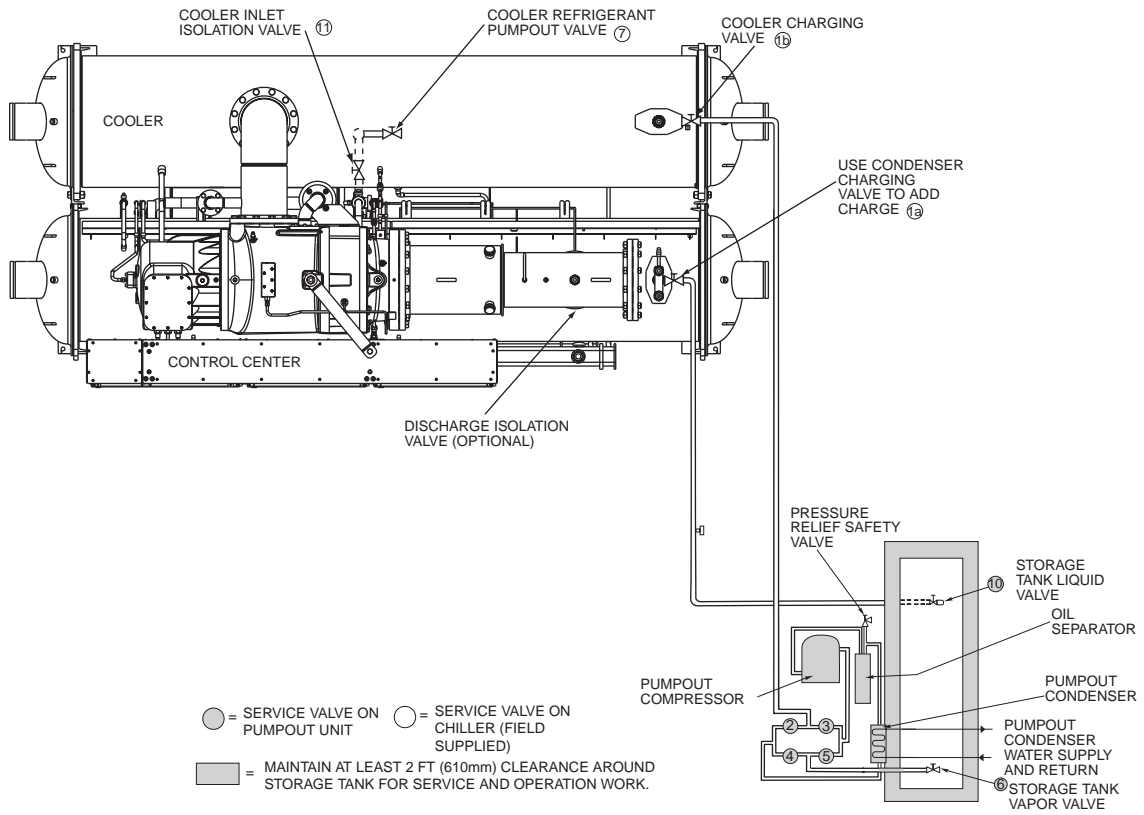
### LEGEND

- ANSI** — American National Standard Institute
- ASHRAE** — American Society of Heating, Refrigeration, and Air Conditioning Engineers
- OD** — Outside Diameter
- UL** — Underwriters Laboratories

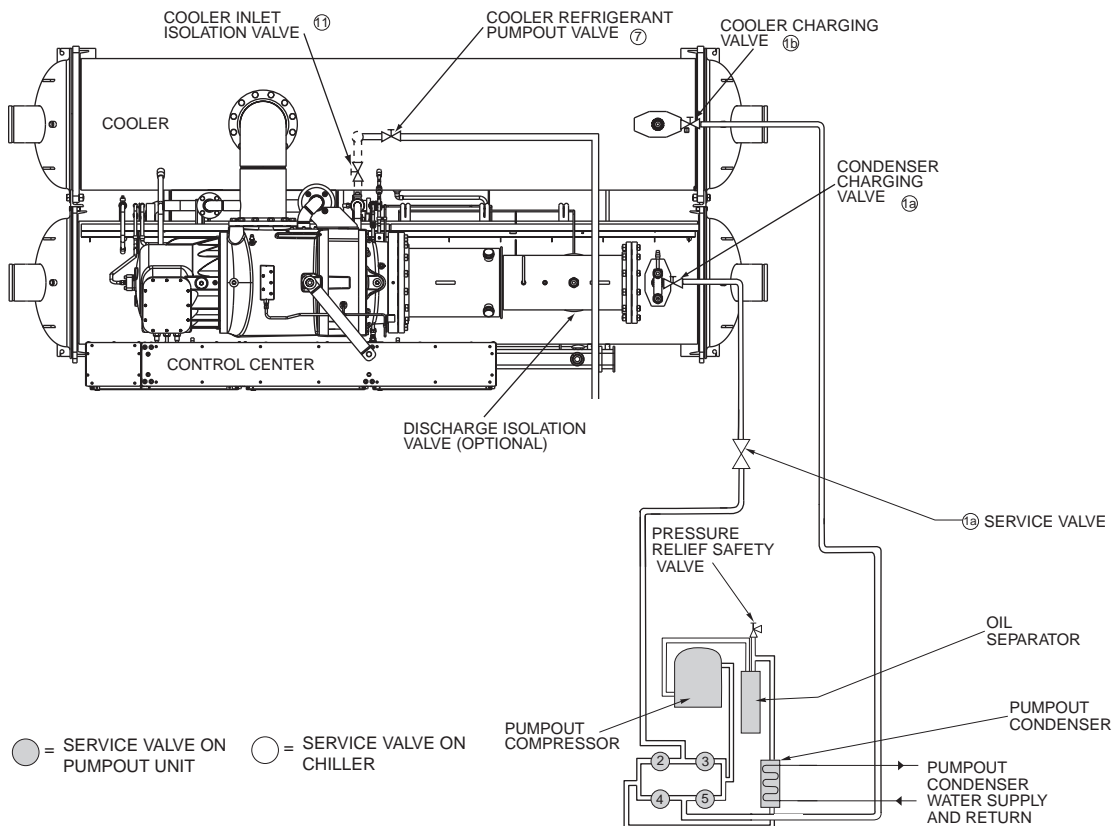
\*The above dry weight includes the pumpout condensing unit weight of 164 lb (75 kg).



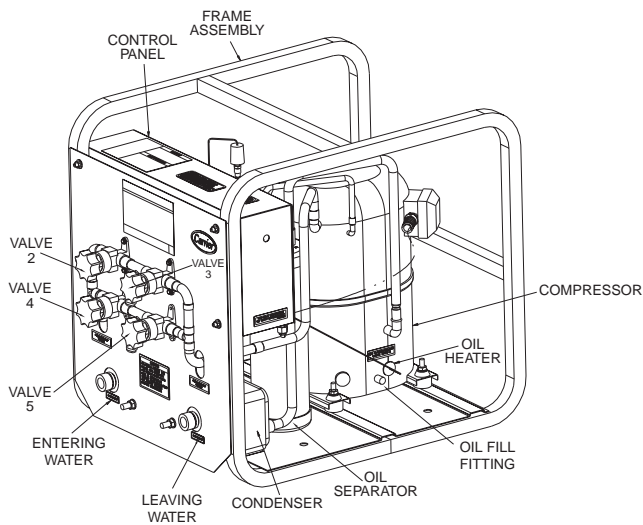
**Fig. 39 — Optional Pumpout System Piping Schematic with Storage Tank (Configured to Push Liquid into Storage Tank)**



**Fig. 40 — Optional Pumpout System Piping Schematic with Storage Tank (Configured to Pull Vapor out of Chiller or to Charge Chiller from Storage Tank)**



**Fig. 41 — Optional Pumpout System Piping Schematic without Storage Tank (Configured to Store Refrigerant in Cooler or Condenser)**



**Fig. 42 — Pumpout Unit**

**INSTALL VENT PIPING TO RELIEF VALVES** — The 23XRV chiller is factory equipped with relief valves on the cooler and condenser shells. Refer to Fig. 43 and Table 11 for size and location of relief devices. Vent relief devices to the outdoors in accordance with ANSI/ASHRAE 15 (latest edition) Safety Code for Mechanical Refrigeration and all other applicable codes.

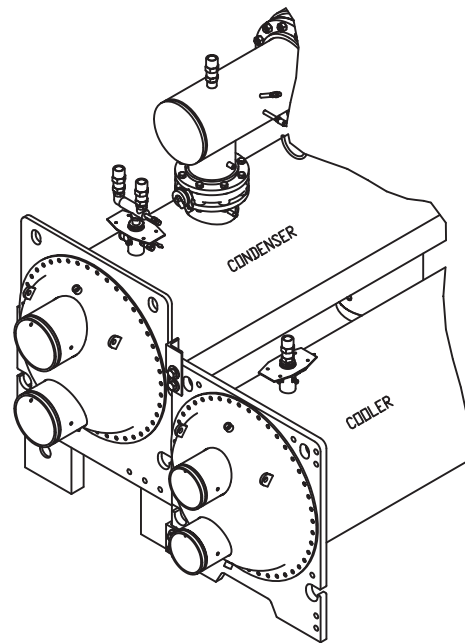
**⚠ DANGER**

Refrigerant discharged into confined spaces can displace oxygen and cause asphyxiation.

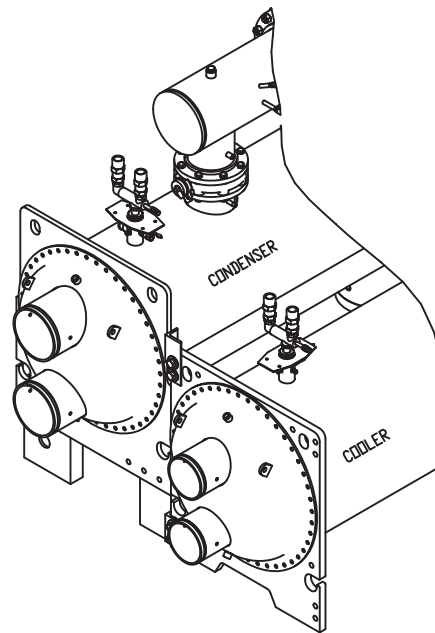
1. Dual pressure relief valves are mounted on the three-way valves in some locations to allow testing and repair without transferring the refrigerant charge. Three-way valve shafts should be turned either fully clockwise or fully counterclockwise so only one relief valve is exposed to refrigerant pressure at a time.

The flow area of discharge piping routed from more than one relief valve, or more than one heat exchanger, must be greater than the sum of the outlet areas of all relief valves that are expected to discharge simultaneously. All relief valves within a machinery room that are exposed to refrigerant may discharge simultaneously in the event of a fire. Discharge piping should lead to the point of final release as directly as possible with consideration of pressure drop in all sections downstream of the relief valves.

2. Provide a pipe plug near outlet side of each relief device for leak testing. Provide pipe fittings that allow vent piping to be disconnected periodically for inspection of valve mechanism.
3. Piping to relief devices must not apply stress to the device. Adequately support piping. A length of flexible tubing or piping near the relief device is essential on spring-isolated machines.
4. Cover the outdoor vent with a rain cap and place a condensation drain at the low point in the vent piping to prevent water build-up on the atmospheric side of the relief device.



WITH ISOLATION VALVES



WITHOUT ISOLATION VALVES

**Fig. 43 — Relief Valve Arrangements**

**Make Electrical Connections** — Field wiring must be installed in accordance with job wiring diagrams and all applicable electrical codes. Refer to Fig. 44 and 45 for typical wiring and component layout.

**⚠ DANGER**

Only qualified electrical personnel familiar with the construction and operation of this equipment and the hazards involved should install, adjust, operate, or service this equipment. Read and understand this manual and other applicable manuals in their entirety before proceeding. Failure to observe this precaution could result in severe bodily injury or loss of life.

**Table 11 — Relief Valve Locations**

LOCATION	FRAME SIZE	RELIEF VALVE OUTLET SIZE	QUANTITY WITHOUT ISOLATION VALVES	QUANTITY WITH ISOLATION VALVES
Discharge Pipe Assembly	3-5	1 <sup>1</sup> / <sub>4</sub> -in. NPT FEMALE CONNECTOR	0	1
Cooler	3-5	1 <sup>1</sup> / <sub>4</sub> -in. NPT FEMALE CONNECTOR	2	1
Condenser	3-5	1 <sup>1</sup> / <sub>4</sub> -in. NPT FEMALE CONNECTOR	2	2
Optional Storage Tank	N/A	1-in. NPT FEMALE CONNECTOR	2	2

NOTE: All valves relieve at 185 psi (1275 kPa).

**⚠ DANGER**

DC bus capacitors in the VFD retain hazardous voltages after input power has been disconnected. After disconnecting input power, wait 5 minutes for the DC bus capacitors to discharge then check both the VFD DPI Communications Interface Board Status LEDs and the VFD with a voltmeter to ensure the DC bus capacitors are discharged before touching any internal components. Failure to observe this precaution could result in severe bodily injury or loss of life.

**⚠ DANGER**

The drive can operate at and maintain zero speed. The user is responsible for assuring safe conditions for operating personnel by providing suitable guards, audible or visual alarms, or other devices to indicate that the drive is operating or may operate at or near zero speed. Failure to observe this precaution could result in severe bodily injury or loss of life.

**⚠ DANGER**

Do not install modification kits with power applied to the drive. Disconnect and lockout incoming power before attempting such installation or removal. Failure to observe this precaution could result in severe bodily injury or loss of life.

**⚠ DANGER**

The drive contains ESD (Electrostatic Discharge) sensitive parts and assemblies. Static control precautions are required when installing, testing, servicing, or repairing the drive. Erratic machine operation and damage to, or destruction of, equipment can result if this procedure is not followed. Failure to observe this precaution could result in bodily injury.

**⚠ CAUTION**

The user is responsible for conforming with all applicable local, national and international codes. Failure to observe this precaution could result in damage to, or destruction of, the equipment.

These instructions are intended for qualified electrical personnel familiar with servicing and installing AC drives. Any questions or problems with the products described in this manual should be directed to your local Carrier Service Office.

Wiring diagrams in this publication are for reference only and are not intended for use during actual installation; follow job specific wiring diagrams.

**⚠ CAUTION**

Do not attempt to start compressor (even for a rotation check) or apply test voltage of any kind while machine is under dehydration vacuum. Motor insulation breakdown and serious damage may result.

**⚠ CAUTION**

Low oil level may result if the oil pump is manually operated for more than a few minutes when the chiller is not running. The oil reclaim system does not return oil to the sump when the compressor is de-energized.

**GROUNDING THE CONTROLS/DRIVE ENCLOSURE —**  
Use the following steps to ground the drive.

1. Open the left door of the control center.
2. Run a suitable equipment grounding conductor unbroken from the drive to earth ground. Tighten these grounding connections to the proper torque. See Fig. 6 and 29.
3. Close the door to the control center.

**INSTALLING INPUT POWER WIRING —** All wiring should be installed in conformance with the applicable local, national, and international codes (e.g., NEC/CEC). Signal wiring, control wiring, and power wiring must be routed in separate conduits to prevent interference with the drive operation. Use grommets, when hubs are not provided, to guard against wire chafing.

Use the following steps to connect AC input power to the main input circuit breaker:

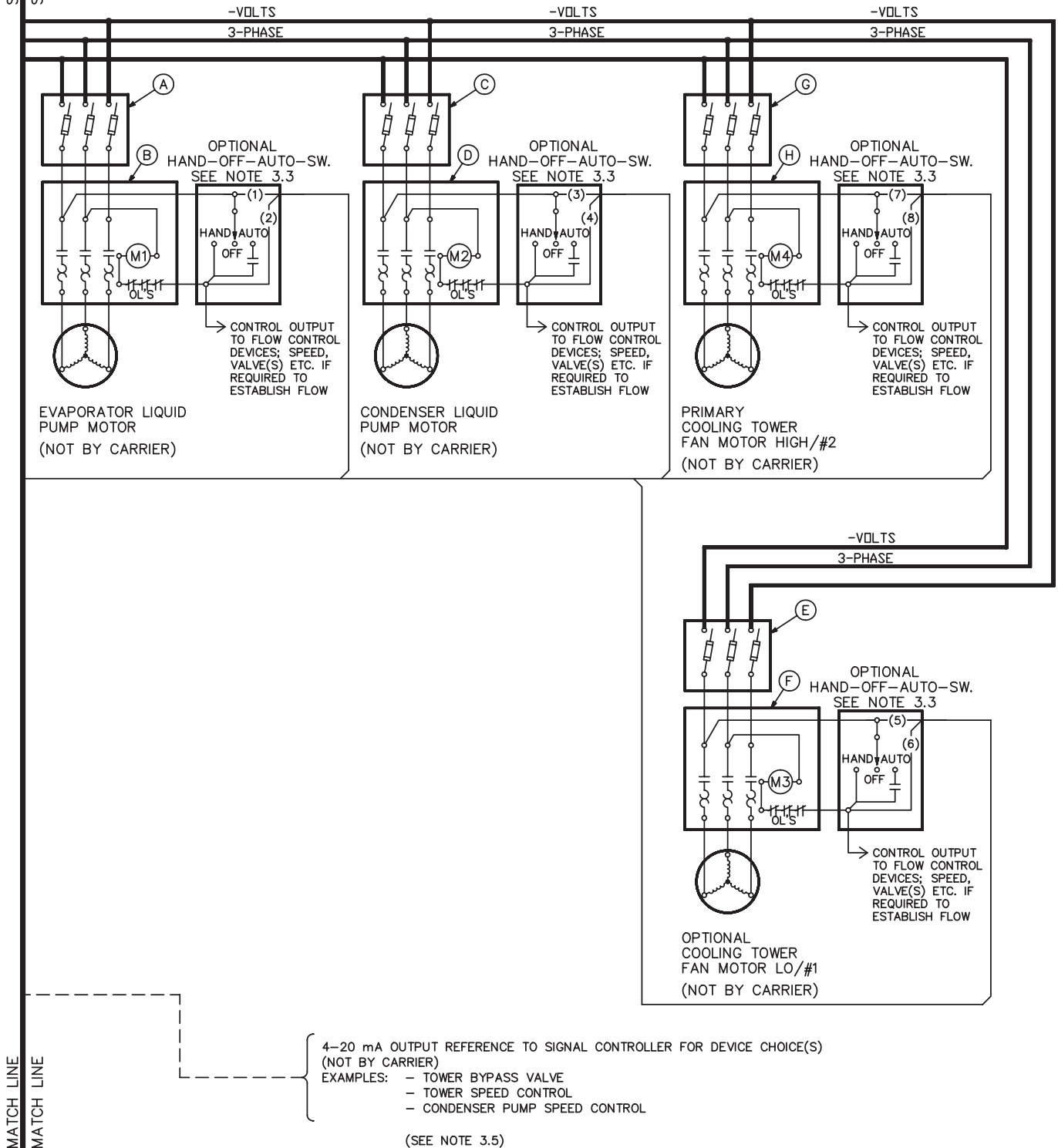
1. Turn off, lock out, and tag the input power to the drive.
2. Remove the input power wiring panel above the VFD circuit breaker and drill the number of openings for the AC input leads (refer to Fig. 6). Mount all conduit hardware on the input power wiring panel before re-installing the input power wiring panel on the VFD enclosure. Take care that metal chips and hardware do not enter the enclosure.
3. Wire the AC input leads by routing them through the openings in the input power wiring panel.

**⚠ CAUTION**

Do not route signal and control wiring with power wiring in the same conduit. This can cause interference with control and drive operation. Failure to observe this precaution could result in damage to, or destruction of, the equipment.

4. Connect the three-phase AC input power leads (per job specifications) to the appropriate input terminals of the circuit breaker. See Fig. 6.
5. Tighten the AC input power terminals and lugs to the proper torque as specified on the input circuit breaker.





4-20 mA OUTPUT REFERENCE TO SIGNAL CONTROLLER FOR DEVICE CHOICE(S)  
(NOT BY CARRIER)  
 EXAMPLES: - TOWER BYPASS VALVE  
 - TOWER SPEED CONTROL  
 - CONDENSER PUMP SPEED CONTROL  
 (SEE NOTE 3.5)

Fig. 44 — Typical Field Wiring Schematic (cont)

ITEM	DESCRIPTION	
1	UNIT MOUNTED VFD WITH SHUNT TRIP CIRCUIT BREAKER (65K AMPS INTERRUPT/SHORT CIRCUIT)	
	UNIT MOUNTED VFD WITH SHUNT TRIP CIRCUIT BREAKER (100K AMPS INTERRUPT/SHORT CIRCUIT)	
	INCLUDES:	
	(1) N.O. CHILLED WATER PUMP CONTACT OUTPUT	
	(1) N.O. CONDENSER WATER PUMP CONTACT OUTPUT	
	(1) N.O. TOWER FAN LOW / #1 CONTACT OUTPUT	
	(1) N.O. TOWER FAN HIGH / #2 CONTACT OUTPUT	
	(1) N.O. ALARM CONTACT OUTPUT	
	(1) 4-20mA HEAD PRESSURE REFERENCE OUTPUT	
	(1) N.C. SPARE SAFETY (DRY) CONTACT INPUT	
	(1) N.O. REMOTE START (DRY) CONTACT INPUT	
	(1) N.O. ICE BUILD (DRY) CONTACT INPUT	
	PROTECTION	3 PHASE UNDER / OVER VOLTAGE PROTECTION (LINE SIDE)
		PHASE LOSS / IMBALANCE / REVERSAL PROTECTION (LINE SIDE)
		FREQUENCY SHIFT PROTECTION (LINE SIDE)
		OVER CURRENT PROTECTION (LINE AND LOAD SIDE)
		PHASE TO GROUND FAULT PROTECTION (LINE AND LOAD SIDE)
	METERING	3 PHASE AMPS (CHILLER DISPLAY LINE AND LOAD SIDE)
		3 PHASE VOLTS (CHILLER DISPLAY LINE SIDE)
		4-20mA KW TRANSDUCER OUTPUT (LINE SIDE) FROM CHILLER CONTROL MODULE (CCM)
KW HOURS / DEMAND KW (CHILLER DISPLAY LINE SIDE)		
KW METERING (CHILLER DISPLAY LINE AND LOAD SIDE)		
ANCILLARY	CONTROL POWER TRANSFORMER (3KVA)	
	CONTROLS AND OIL HEATER DISCONNECT	
	3 PHASE ANALOG VOLTS / AMPS METER PACKAGE (OPTION)	
	CE - MARKING (OPTION)	
2	SYSTEM FEEDER (SHORT CIRCUIT, GROUND FAULT & PROTECTION)	
A	EVAPORATOR LIQUID PUMP STARTER DISCONNECT	
B	EVAPORATOR LIQUID PUMP MOTOR STARTER	
C	CONDENSER LIQUID PUMP STARTER DISCONNECT	
D	CONDENSER LIQUID PUMP MOTOR STARTER	
E	COOLING TOWER FAN STARTER DISCONNECT (LOW FAN/#1)	
F	COOLING TOWER FAN STARTER (LOW FAN/#1)	
G	COOLING TOWER FAN STARTER DISCONNECT (HIGH FAN/#2)	
H	COOLING TOWER FAN STARTER (HIGH FAN/#2)	
J	SPARE SAFETY DEVICES [ N.C. ] SEE NOTE 3.1	
K	REMOTE START / STOP DEVICE [ N.O. ] SEE NOTE 3.1	
L	REMOTE ALARM SEE NOTE 3.3	
M	REMOTE ANNUNCIATOR SEE NOTE 3.3	
N	LINE SIDE LUG ADAPTERS SEE NOTE 2.3	
P	ICE BUILD START / TERMINATE DEVICE SEE NOTE 3.1	

**Fig. 44 — Typical Field Wiring Schematic (cont)**

## NOTES FOR FIG. 44

### GENERAL

- 1.0 Variable frequency drive (VFD) shall be designed and manufactured in accordance with Carrier engineering requirements.
- 1.1 All field-supplied conductors, devices and the field-installation wiring, termination of conductors and devices, must be in compliance with all applicable codes and job specifications.
- 1.2 The routing of field-installed conduit and conductors and the location of field-installed devices, must not interfere with equipment access or the reading, adjusting or servicing of any component.
- 1.3 Equipment installation and all starting and control devices, must comply with details in equipment submittal drawings and literature.
- 1.4 Contacts and switches are shown in the position they would assume with the circuit de-energized and the chiller shutdown.
- 1.5

### ⚠ WARNING

Do not use aluminum conductors. Contractor/installer assumes all liability resulting from the use of aluminum conductors within the VFD enclosure.

### POWER WIRING TO VFD

- 2.0 Provide a means of disconnecting branch feeder power to VFD. Provide short circuit protection and interrupt capacity for branch feeder in compliance with all applicable codes.
- 2.1 If metal conduit is used for the power wires, the last 4 feet or greater should be flexible to avoid transmitting unit vibration into the power lines and to aid in serviceability.
- 2.2 Line side power conductor rating must meet VFD nameplate voltage and chiller minimum circuit ampacity.
- 2.3 Lug adapters may be required if installation conditions dictate that conductors be sized beyond the minimum ampacity required. Circuit breaker lugs will accommodate the quantity (#) and size cables (per phase) as shown in Table 12.
- 2.4 Compressor motor and controls must be grounded by using equipment grounding lug provided inside unit mounted VFD enclosure.

### CONTROL WIRING

- 3.0 Field-supplied control conductors to be at least 18 AWG or larger.

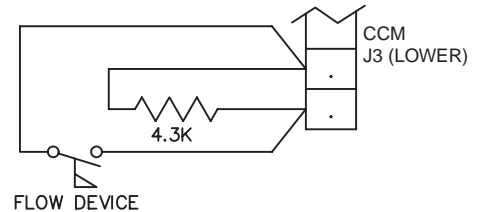
- 3.1 Ice build start/terminate device contacts, remote start/stop device contacts and spare safety device contacts, (devices not supplied by Carrier), must have 24 VAC rating. Max current is 60 mA, nominal current is 10 mA. Switches with gold plated bifurcated contacts are recommended.
- 3.2 Remove jumper wire between TB1-19 and TB1-20 before connecting auxiliary safeties between these terminals.
- 3.3 Each integrated contact output can control loads (VA) for evaporator pump, condenser pump, tower fan low, tower fan high, and alarm annunciator devices rated 5 amps at 115 VAC and up to 3 amps at 277 VAC.

### ⚠ WARNING

Control wiring required for Carrier to start pumps and tower fan motors and establish flows must be provided to assure machine protection. If primary pump, tower fan and flow control is by other means, also provide a parallel means for control by Carrier. Failure to do so could result in machine freeze-up or over-pressure.

Do not use control transformers in the control center as the power source for external or field-supplied contactor coils, actuator motors or any other loads.

- 3.4 Do not route control wiring carrying 30 V or less within a conduit or tray which has wires carrying 50 V or higher or along side wires carrying 50 V or higher.
- 3.5 Spare 4-20 mA output signal is designed for controllers with a non-grounded 4-20 mA input signal and a maximum input impedance of 500 ohms.
- 3.6 Flow devices to confirm evaporator or condenser pump flow are not required. However; if flow devices are used, wire as shown on drawing 23XRC1-1 (J3 lower). Remove jumper installed at these terminals and wire in a 4.3 K resistor in its place.

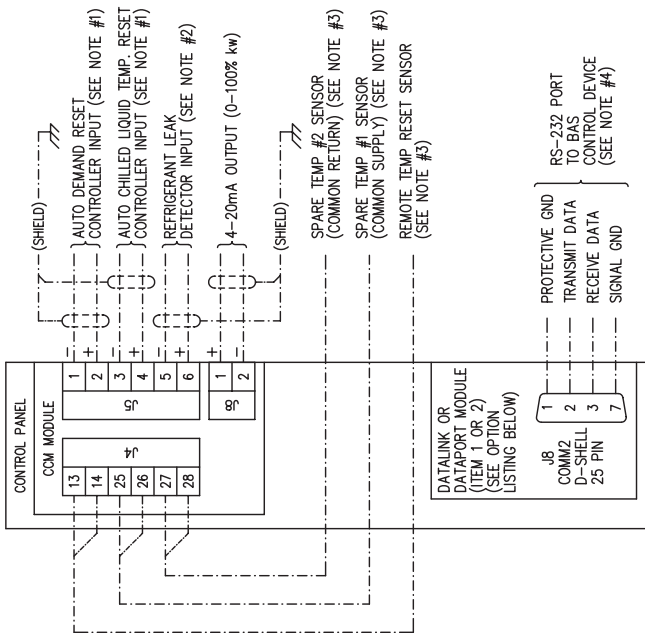


The flow device and resistor must be installed in parallel at these terminals such that the resistor provides a signal when the flow device is open.

**Table 12 — Lug Capacity**

VFD MAX. INPUT AMPS.	STANDARD 65K AIC LUG CAPACITY (PER PHASE)		OPTIONAL 100K AIC LUG CAPACITY (PER PHASE)	
	No. Conductors	Conductor Range	No. Conductors	Conductor Range
<b>225A</b>	3	3/0 — 500MCM	2	3/0 — 250MCM
<b>338A</b>	3	3/0 — 500MCM	2	400 — 500MCM
<b>440A</b>	3	3/0 — 500MCM	2	400 — 500MCM
<b>520A</b>	3	3/0 — 500MCM	3	3/0 — 400MCM
<b>608A</b>	3	3/0 — 500MCM	3	3/0 — 400MCM

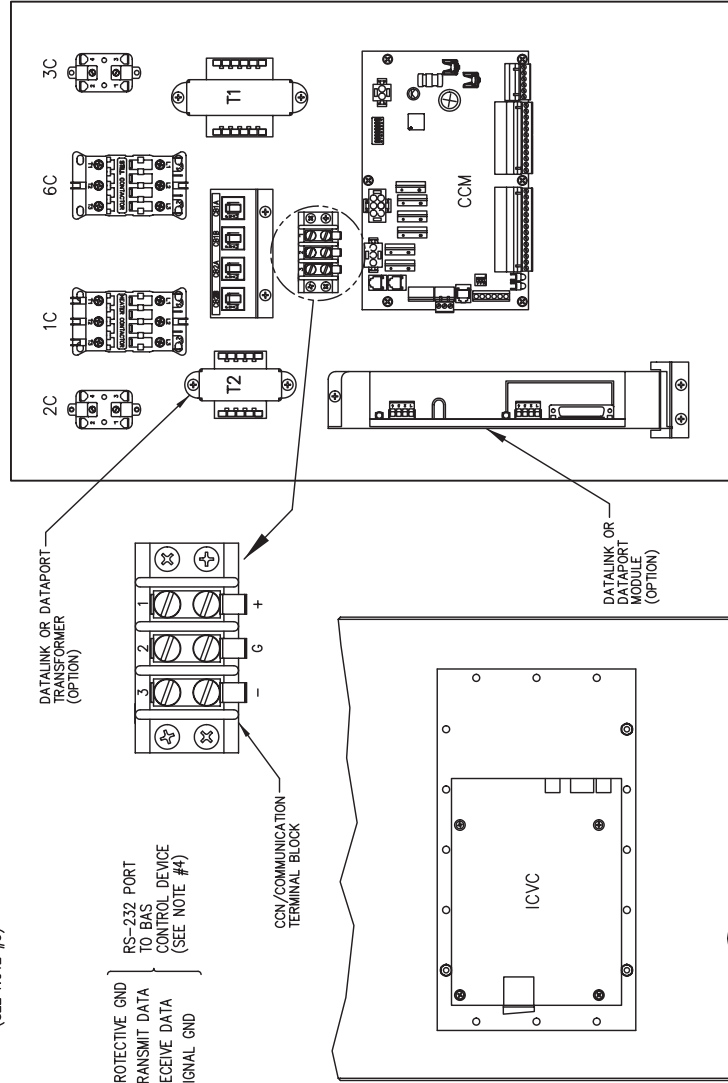
NOTE: If larger lugs are required, they can be purchased from the manufacturer of the circuit breaker (Cutler-Hammer or Square D).



CONTROL PANEL OPTIONAL WIRING

NOTES:

1. THIS FEATURE IS STANDARD IN THE 23XR CONTROLS, BUT REQUIRES CONTROLLER WITH A NON-GROUNDED 4-20mA OR 1-5Vdc OUTPUT SIGNAL, NOT BY CARRIER.
2. THIS FEATURE IS STANDARD IN THE 23XR CONTROLS, BUT REQUIRES AN EXTERNAL CONTROLLER WITH A NON-GROUNDED 4-20mA OUTPUT SIGNAL, NOT BY CARRIER.
3. THIS FEATURE IS STANDARD IN THE 23XR CONTROLS, BUT REQUIRES A SENSOR PACKAGE OPTION, BY CARRIER. (ITEM #3 SEE OPTION LISTING)
4. PINS SHOWN FOR REFERENCE ONLY. ACTUAL PIN LAYOUT NOT SHOWN.



CONTROL PANEL COMPONENT LAYOUT

INSIDE PANEL DOOR

OPTION LISTING		CHECK TO ORDER
ITEM	DESCRIPTION	
1	DATAPORT MODULE	
2	DATALINK MODULE	
3	SENSOR PACKAGE	

Fig. 45 — PIC III Control Component Layout

**WIRING THE FIELD WIRING TERMINAL STRIPS** — This section describes how to wire the field wiring terminal strips shown in Fig. 46 and 47. The control terminal blocks are mounted to the inside of the enclosure, above and below the control panel.

**NOTE:** Up to 30 v may be measured across open contact terminals on the hazardous voltage terminal strip.

1. Turn off, lock out, and tag the input power to the drive. Wait five minutes.
2. Verify that there is no voltage at the input terminals (L1, L2, and L3) of the power module.
3. Verify that the status LEDs on the Communications Interface Board are not lit. See Fig. 48. The location of the Communications Interface Board is shown in Fig. 6.
4. Use a screwdriver to remove conduit twist outs in the control panel. Do not punch holes or drill into the top surface of the control center enclosure for field wiring. Knockouts are provided in the back of the control center for field wiring connections.
5. Connect the control wiring as shown in Fig. 47. Tighten all connections to 7 to 9 in-lb.

**CONNECT CONTROL INPUTS** — Wiring may be specified for a spare safety switch, and a remote start/stop contact can be wired to the starter terminal strip. Additional spare sensors and Carrier Comfort Network® modules may be specified as well. These are wired to the machine control panel as indicated in Fig. 49.

**CONNECT CONTROL OUTPUTS** — Connect auxiliary equipment, chilled and condenser water pumps, and spare alarms as required and indicated on job wiring drawings.

**CONNECT STARTER** — The 23XRV is equipped with a unit-mounted VFD starter (Fig. 50).

**IMPORTANT:** Be sure to ground the power circuit in accordance with the National Electrical Code (NEC), applicable local codes, and job wiring diagrams. Also, make sure correct phasing is observed for proper rotation.

**⚠ CAUTION**

Do not punch holes or drill into the top surface of the control center. Knockouts are provided in the back of the control center for wiring connections.

Remove the VFD shipping bracket shown in Fig. 16.

NOTE:  
GROUND SHIELDS AT SIGNAL  
GENERATING DEVICES.

AUTO DEMAND LIMIT  
(OPTIONAL)

AUTO CHILLED LIQUID TEMP.  
RESET  
(OPTIONAL)

REFRIGERANT LEAK SENSOR  
(OPTIONAL)

EVAP ENT  
LIQUID TEMP  
EVAP LVG  
LIQUID TEMP  
COND ENT  
LIQUID TEMP  
COND LVG  
LIQUID TEMP

EVAP REFRIG  
LIQUID TEMP  
REMOTE TEMP  
RESET  
(OPTIONAL)

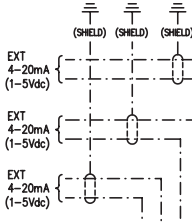
COMP'R  
DISCH TEMP  
VAPORIZER  
TEMP  
COMP'R OIL  
SLUMP TEMP

NOISE  
SUPPRESSOR  
COMP'R MOTOR  
WINDING TEMP  
SPARE TEMP #1  
(OPTIONAL)  
SPARE TEMP #2  
(OPTIONAL)

OIL SLUMP  
PRESSURE  
OIL PRESSURE  
LEAVING FILTER  
LOAD RESISTOR  
RELATIVE  
HUMIDITY  
DISCHARGE  
PRESSURE

LOAD RESISTOR  
EVAP LIQUID FLOW  
CIRCUIT. TO INSTALL  
OPTIONAL FLOW  
DEVICE WIRE AS  
SHOWN (N.O.) AND  
REPLACE JUMPER  
WITH 4.3K RESISTOR  
COND LIQUID FLOW  
CIRCUIT. TO INSTALL  
OPTIONAL FLOW  
DEVICE WIRE AS  
SHOWN (N.O.) AND  
REPLACE JUMPER  
WITH 4.3K RESISTOR

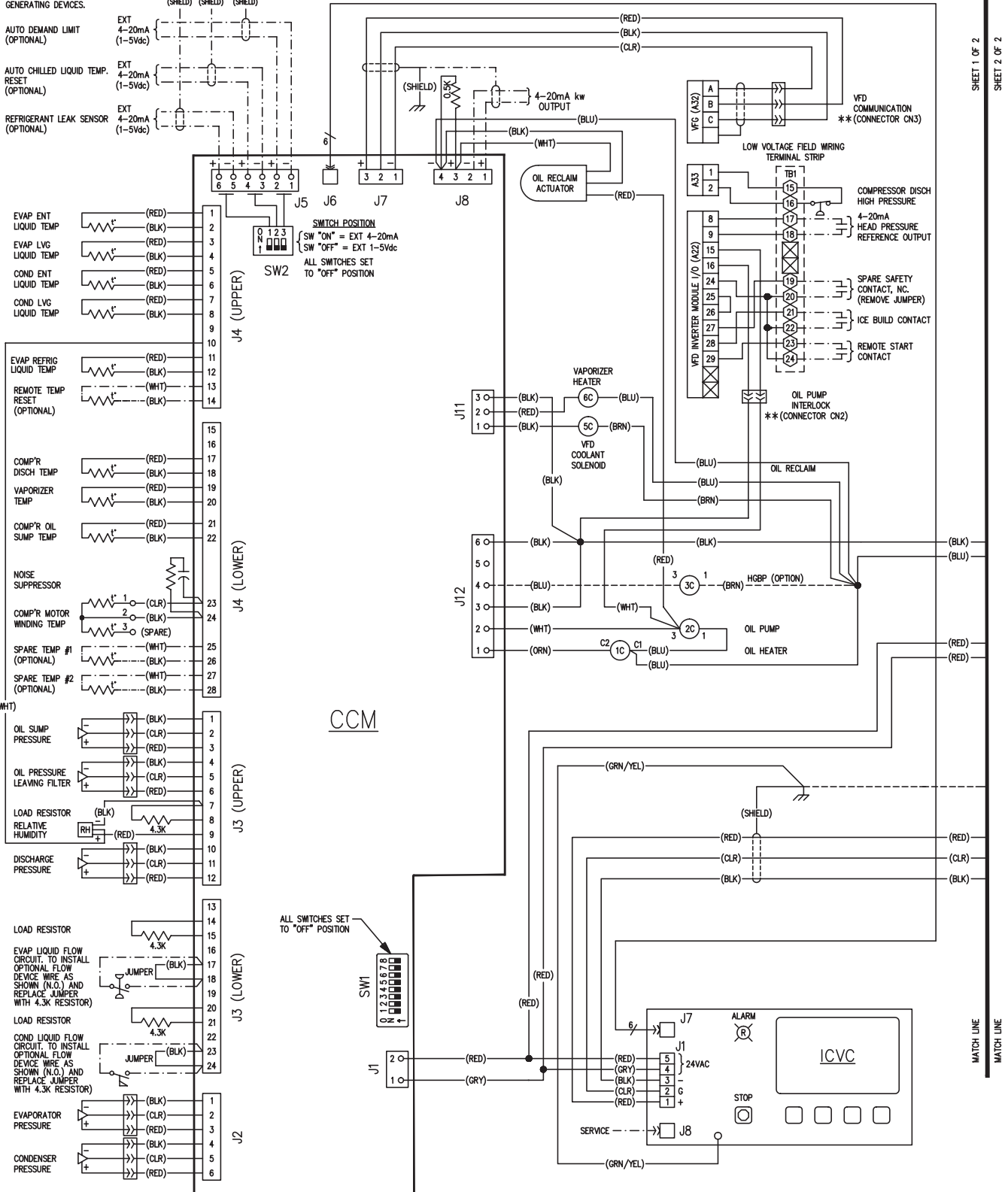
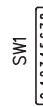
EVAPORATOR  
PRESSURE  
CONDENSER  
PRESSURE



SW2  
SWITCH POSITION  
SW "ON" = EXT 4-20mA  
SW "OFF" = EXT 1-5Vdc  
ALL SWITCHES SET  
TO "OFF" POSITION

CCM

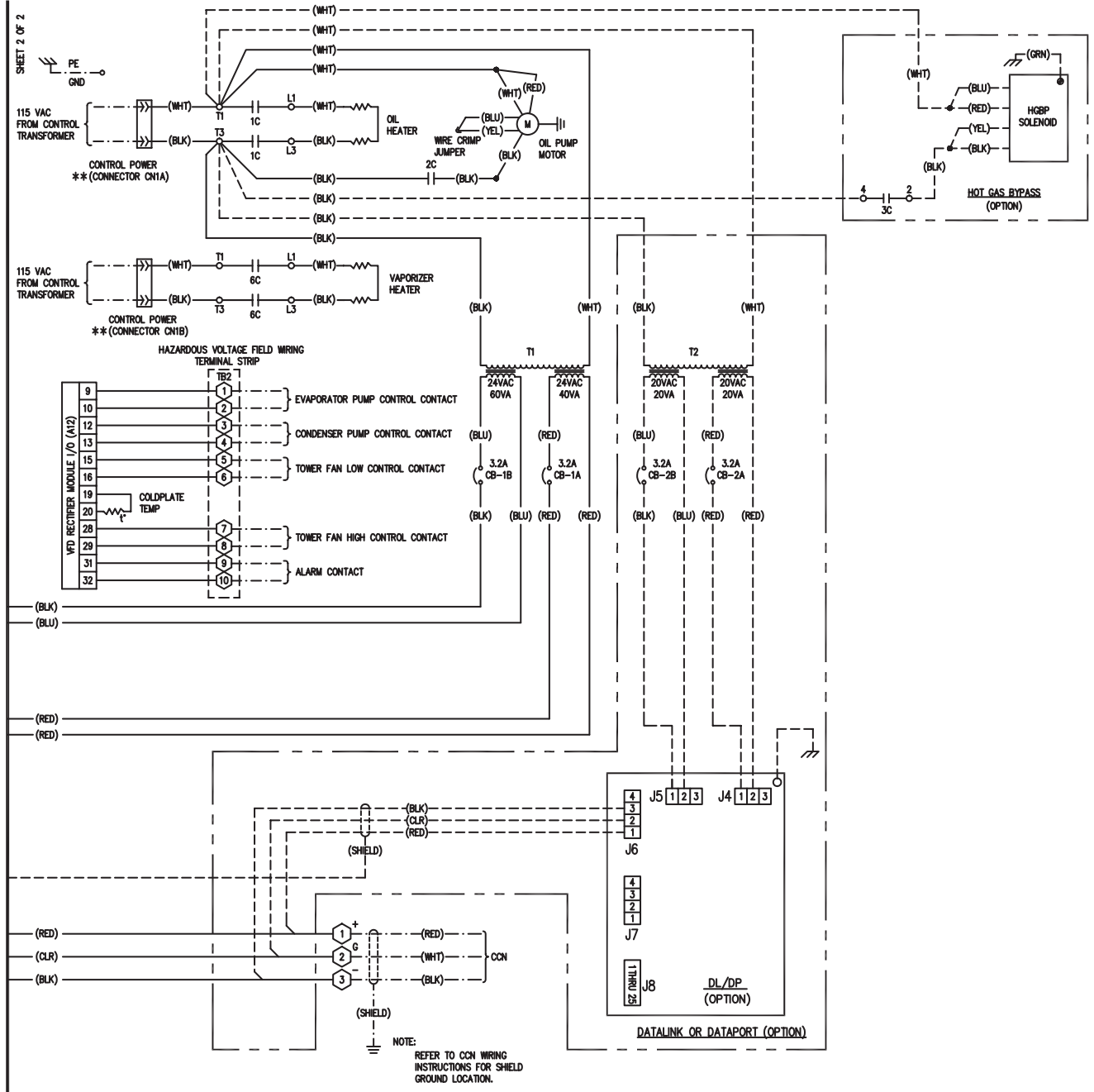
ALL SWITCHES SET  
TO "OFF" POSITION



SHEET 1 OF 2  
SHEET 2 OF 2

MATCH LINE  
MATCH LINE

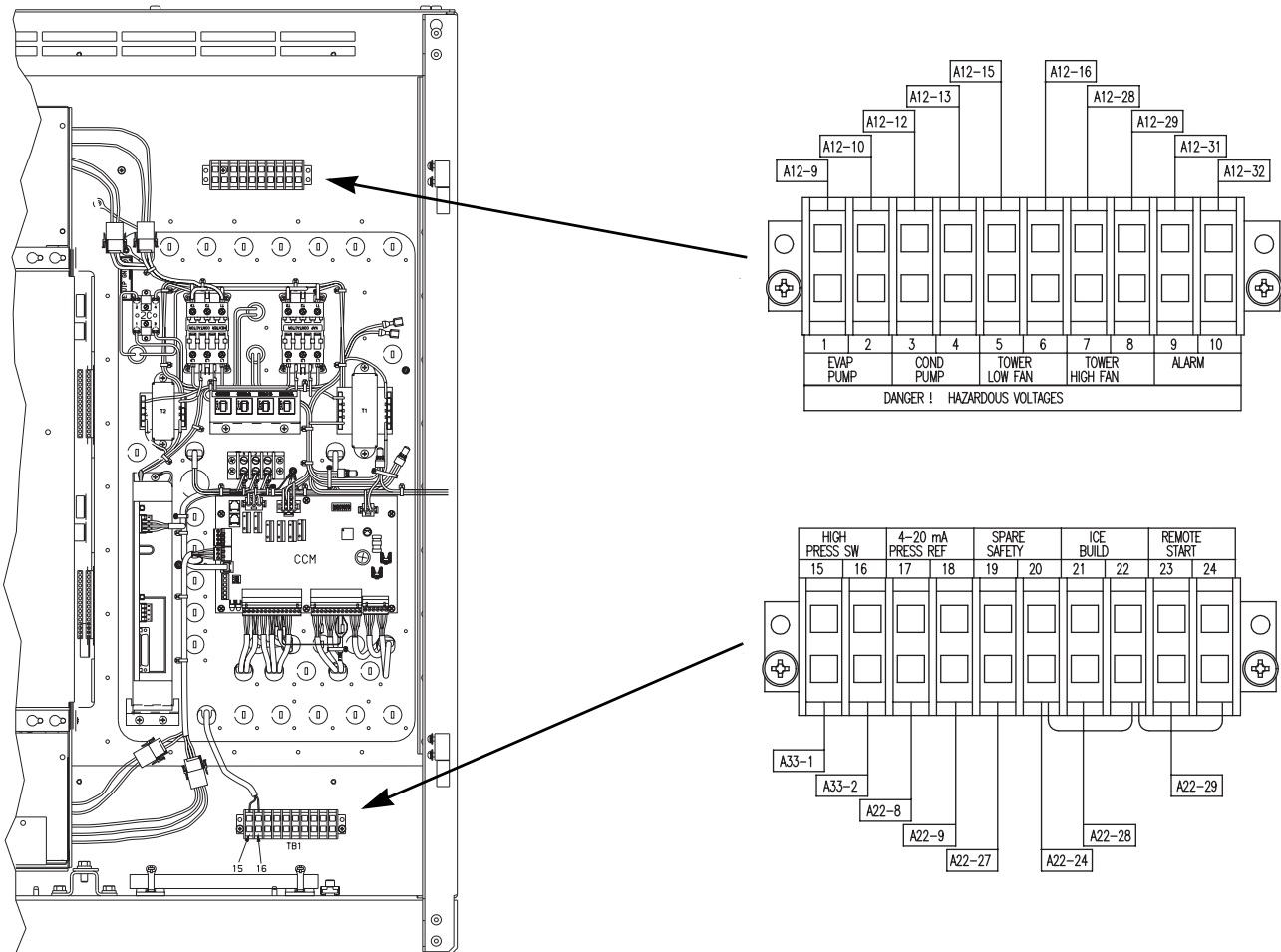
Fig. 46 — 23XRV Controls Schematic



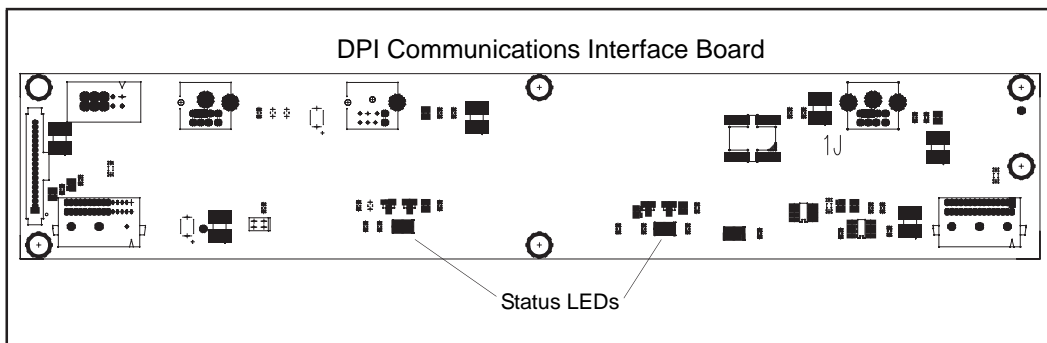
NOTE:  
REFER TO CCN WIRING  
INSTRUCTIONS FOR SHIELD  
GROUND LOCATION.

LEGEND		ABBREVIATION LISTING	
	DENOTES FIELD WIRING TERMINAL	A12	VFD TERMINAL BOARD (EXAMPLE A12)
	DENOTES 3.2A CIRCUIT BREAKER	CB-XX	CIRCUIT BREAKER (EXAMPLE CB-1B)
	DENOTES FACTORY WIRING TERMINAL	CCM	CHILLER CONTROL MODULE
**	DENOTES VFD TO CONTROL PANEL CONNECTOR	CCN	CARRIER COMFORT NETWORK
o	DENOTES 115V COMPONENT TERMINAL	DL/DP	DATALINK OR DATAPORT
•	WIRE SPLICE	HGBP	HOT GAS BYPASS
	DENOTES CONDUCTOR MALE/FEMALE CONNECTOR	ICVC	INTERNATIONAL CHILLER VISUAL CONTROLLER
- - -	OPTION WIRING	VFD	VARIABLE FREQUENCY DRIVE
- · - · -	FIELD WIRING	VFG	VARIABLE FREQUENCY (DRIVE) GATEWAY
	DENOTES HUMIDITY SENSOR		

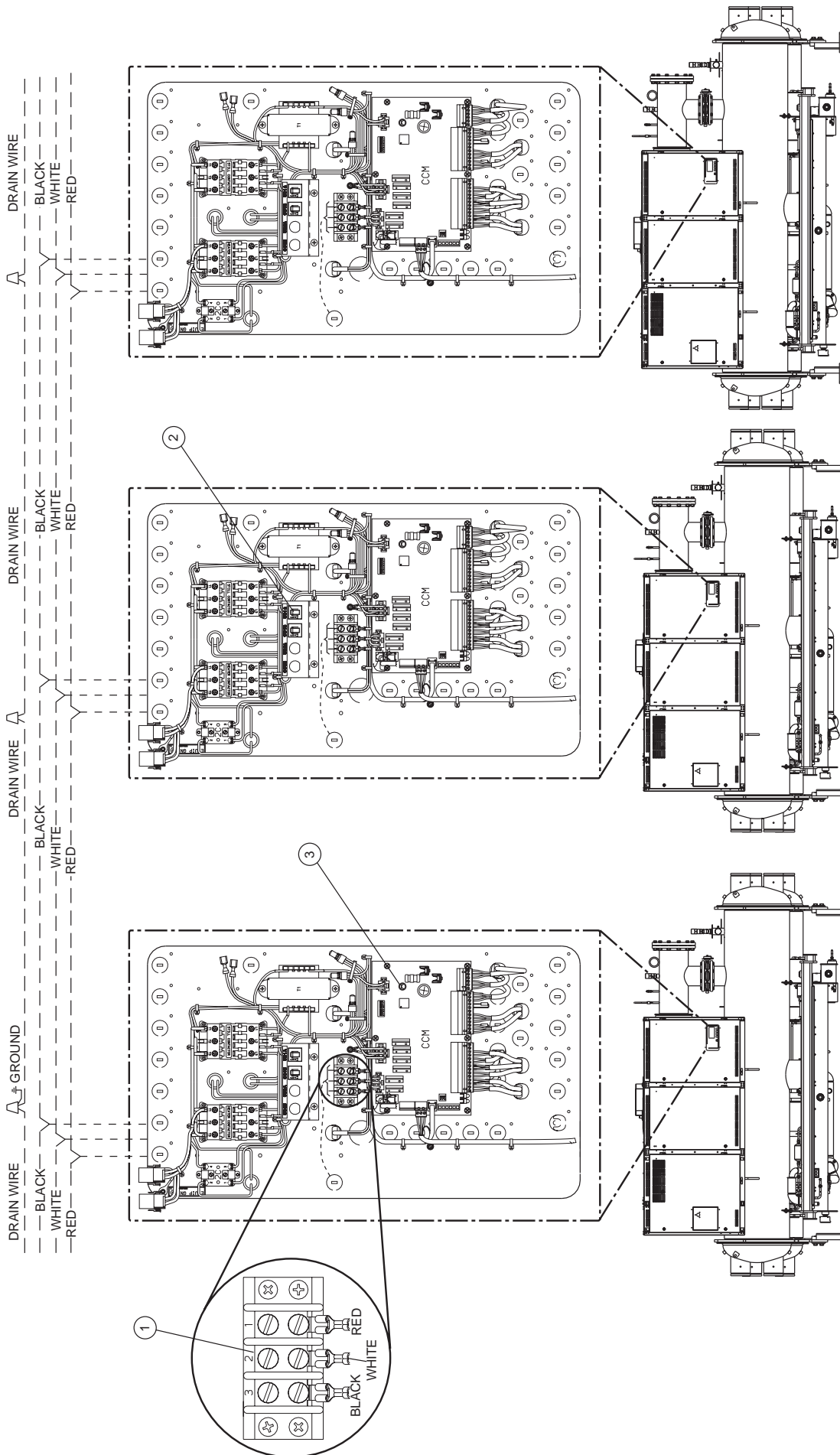
Fig. 46 — 23XRV Controls Schematic (cont)



**Fig. 47 — Control Terminal Blocks**



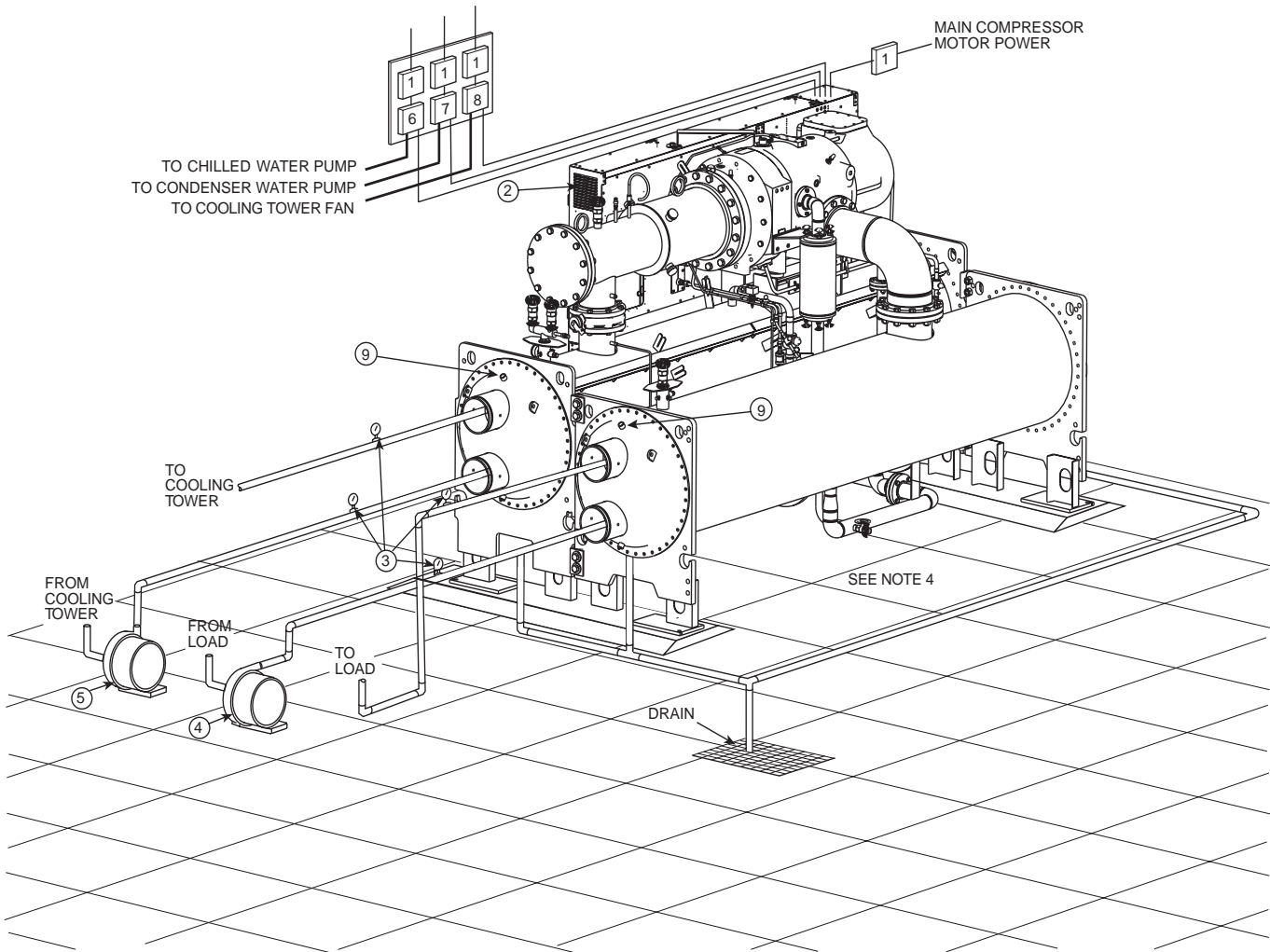
**Fig. 48 — Communications Interface Board Status Lights**



NOTE: Field-supplied terminal strip must be located in control panel.

- LEGEND
- 1 — Carrier Comfort Network® (CCN) Interface
  - 2 — Circuit Breakers
  - 3 — Chiller Control Module (CCM)
  - Factory Wiring
  - - - Field Wiring

Fig. 49 — CCN Communication Wiring For Multiple Chillers (Typical)



**LEGEND**

- 1 — Disconnect (Fused on VFD only) NOT by Carrier
- 2 — Unit Mounted VFD/Control Center
- 3 — Pressure Gages
- 4 — Chilled Water Pump
- 5 — Condenser Water Pump
- 6 — Chilled Water Pump Starter
- 7 — Condensing Water Pump Starter
- 8 — Cooling Tower Fan Starter
- 9 — Vents
- Piping
- Control Wiring
- Power Wiring

**IMPORTANT:** Wiring and piping shown are for general point-of-connection only and are not intended to show details for a specific installation. Certified field wiring and dimensional diagrams are available on request.

**NOTES:**

1. All wiring must comply with applicable codes.
2. Refer to Carrier System Design Manual for details regarding piping techniques.
3. Wiring not shown for optional devices such as:
  - remote start-stop
  - remote alarm
  - optional safety device
  - 4 to 20 mA (1 to 5 VDC) resets
  - optional remote sensors
  - kW output
  - head pressure reference
4. Service clearance under the chiller can be enhanced if the grout is not extended along the entire length of the heat exchangers.
5. Carrier does not recommend pre-fab water piping.

6. Field-installed piping must be arranged and supported to avoid stress on the equipment and transmission of vibrations from the equipment as well as to prevent interference with routine access for the reading, adjusting and servicing of the equipment. Provisions shall be made for adjustment in each plane of the piping and for periodic and major servicing of the equipment.
7. Relief valves on the cooler and condenser must be vented to the outdoors as discharging refrigerant in closed spaces may displace oxygen and cause asphyxiation. All field-supplied refrigerant relief piping and devices must be used in accordance with ANSI/ASHRAE standard 15.

Dual pressure relief valves are mounted on the three-way valves in some locations to allow testing and repair without transferring the refrigerant charge. Three-way valve shafts should be turned either fully clockwise or fully counterclockwise so only one relief valve is exposed to refrigerant pressure at a time.

The flow area of discharge piping routed from more than one relief valve, or more than one heat exchanger, must be greater than the sum of the outlet areas of all relief valves that are expected to discharge simultaneously. All relief valves within a machinery room that are exposed to refrigerant may discharge simultaneously in the event of a fire. Discharge piping should lead to the point of final release as directly as possible with consideration of pressure drop in all sections downstream of the relief valves.

8. Service access should be provided per standards ANSI/ASHRAE 15 and ANSI/NFPA 70 (NEC) and local safety codes. Unobstructed space adequate for inspection, servicing and rigging of all major components of the chiller is required. Shaded service areas are shown on the certified machine assembly drawing plan view and front view. See machine assembly component disassembly drawing for component removal. Space for rigging equipment and compressor removal is not shown.
9. The installation of chilled water and cooling tower water strainers should be considered to prevent debris from collecting in the water-boxes and degrading performance.
10. Flexible conduit should be used for the last few feet to the control center for vibration isolation of power wiring and control wiring.

**Fig. 50 — 23XRV with Unit-Mounted VFD/Control Center**

## COMPLETING THE INSTALLATION

This section provides instructions on how to perform a final check of the installation. Do not energize the VFD circuit breaker. This should only be done by qualified Carrier personnel in accordance with the 23XRV Start-Up and Service Manual.

**Checking the Installation** — Use the following procedure to verify the condition of the installation:

### **⚠ DANGER**

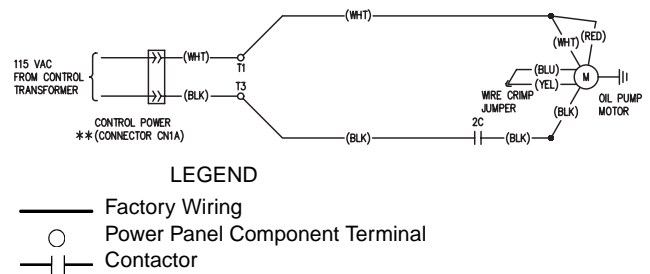
DC bus capacitors in the VFD retain hazardous voltages after input power has been disconnected. After disconnecting input power, wait 5 minutes for the DC bus capacitors to discharge then check both the VFD DPI Communications Interface Board Status LEDs and the VFD with a voltmeter to ensure the DC bus capacitors are discharged before touching any internal components. Failure to observe this precaution could result in severe bodily injury or loss of life.

1. Turn off, lock out, and tag the input power to the drive. Wait five minutes.
2. Verify that there is no voltage at the input terminals (L1, L2, and L3) of the power module.
3. Verify that the status LEDs on the DPI Communications Interface Board are not lit. See Fig. 48. The location of the Communications Interface Board is shown in Fig. 6.
4. Remove any debris, such as metal shavings, from the enclosure.
5. Check that there is adequate clearance around the machine in accordance with the certified print.
6. Verify that the wiring to the terminal strip and the AC input power terminals is correct.
7. Check that the wire size is within terminal specifications and that the wires are tightened properly.
8. Check that specified branch circuit protection is installed and correctly rated.
9. Check that the incoming power is rated correctly.
10. Verify that a properly-sized ground wire is installed and a suitable earth ground is used. Check for and eliminate any grounds between the power leads. Verify that all ground leads are unbroken.

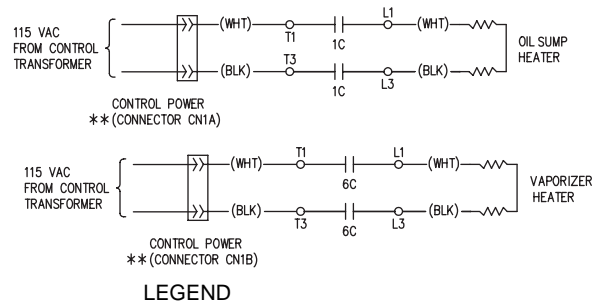
**Oil Pump and Oil Heater** — The oil pump and oil heater are wired at the factory. It is not necessary to connect additional wiring to these components. See Fig. 51 and 52.

### **⚠ WARNING**

Voltage to terminals T1 and T3 on the 1C and 6C contactors comes from a control transformer in the starter built to Carrier specifications. Do not connect an outside source of control power to the chiller (terminals T1 and T3). An outside power source will produce dangerous voltage at the line side of the starter, because supplying voltage at the transformer secondary terminals produces input level voltage at the transformer primary terminals (see Fig. 46, 51, and 52).



**Fig. 51 — Oil Pump Wiring**



**Fig. 52 — Oil Heater and Control Power Wiring**

**Connect Control Wiring** — All control wiring must use shielded cable. Refer to the job wiring diagrams for cable type and cable number. Make sure the control circuit is grounded in accordance with applicable electrical codes and instructions on machine control wiring label.

**Carrier Comfort Network® Interface** — The Carrier Comfort Network (CCN) communication bus wiring is supplied and installed by the electrical contractor. It consists of shielded, 3-conductor cable with drain wire.

The system elements are connected to the communication bus in a daisy chain arrangement. The positive pin of each system element communication connector must be wired to the positive pins of the system element on either side of it. The negative pins must be wired to the negative pins. The signal ground pins must be wired to the signal ground pins. See Fig. 49 for location of the CCN network connections on the terminal strip labelled CCN.

NOTE: Conductors and drain wire must be 20 AWG (American Wire Gage) minimum stranded, tinned copper. Individual conductors must be insulated with PVC, PVC/nylon, vinyl, Teflon, or polyethylene. An aluminum/polyester 100% foil shield and an outer jacket of PVC, PVC/nylon, chrome vinyl, or Teflon with a minimum operating temperature range of -4 F to 140 F (-20 C to 60 C) is required. See Table 13 for cables that meet the requirements.

**Table 13 — Cable Manufacturers**

MANUFACTURER	CABLE NO.
Alpha	2413 or 5463
American	A22503
Belden	8772
Columbia	02525

When connecting the CCN communication bus to a system element, a color code system for the entire network is recommended to simplify installation and checkout. See Table 14 for the recommended color codes:

**Table 14 — Insulator Codes**

SIGNAL TYPE	CCN BUS CONDUCTOR INSULATION COLOR	CCN NETWORK INTERFACE (Control Panel)
+	Red	+
Ground	White	G
-	Black	-

If a cable with a different color scheme is selected, a similar color code should be adopted for the entire network.

NOTE: This color scheme does not apply to SIO wiring between the CCM and Gateway module.

At each system element, the shields of its communication bus cables must be tied together. If the communication bus is entirely within one building, the resulting continuous shield must be connected to ground at only one single point. See Fig. 49. If the communication bus cable exits from one building and enters another, the shields must be connected to ground at the lightning suppressor in each building where the cable enters or exits the building (one point only).

To connect the 23XRV chiller to the network, proceed as follows (see Fig. 49):

1. Route wire through knockout in back of control panel.
2. Strip back leads.
3. Crimp one no. 8 size spring spade terminal on each conductor.

4. Attach red to “+” terminal and white to “G” terminal and black to “-” terminal of CCN Network interface located in the control panel.

**Lead-Lag Control Wiring** — The 23XRV can be wired for lead-lag operation in either series or parallel. See Fig. 53 for applicable wiring schematics.

### Install Field Insulation and Lagging

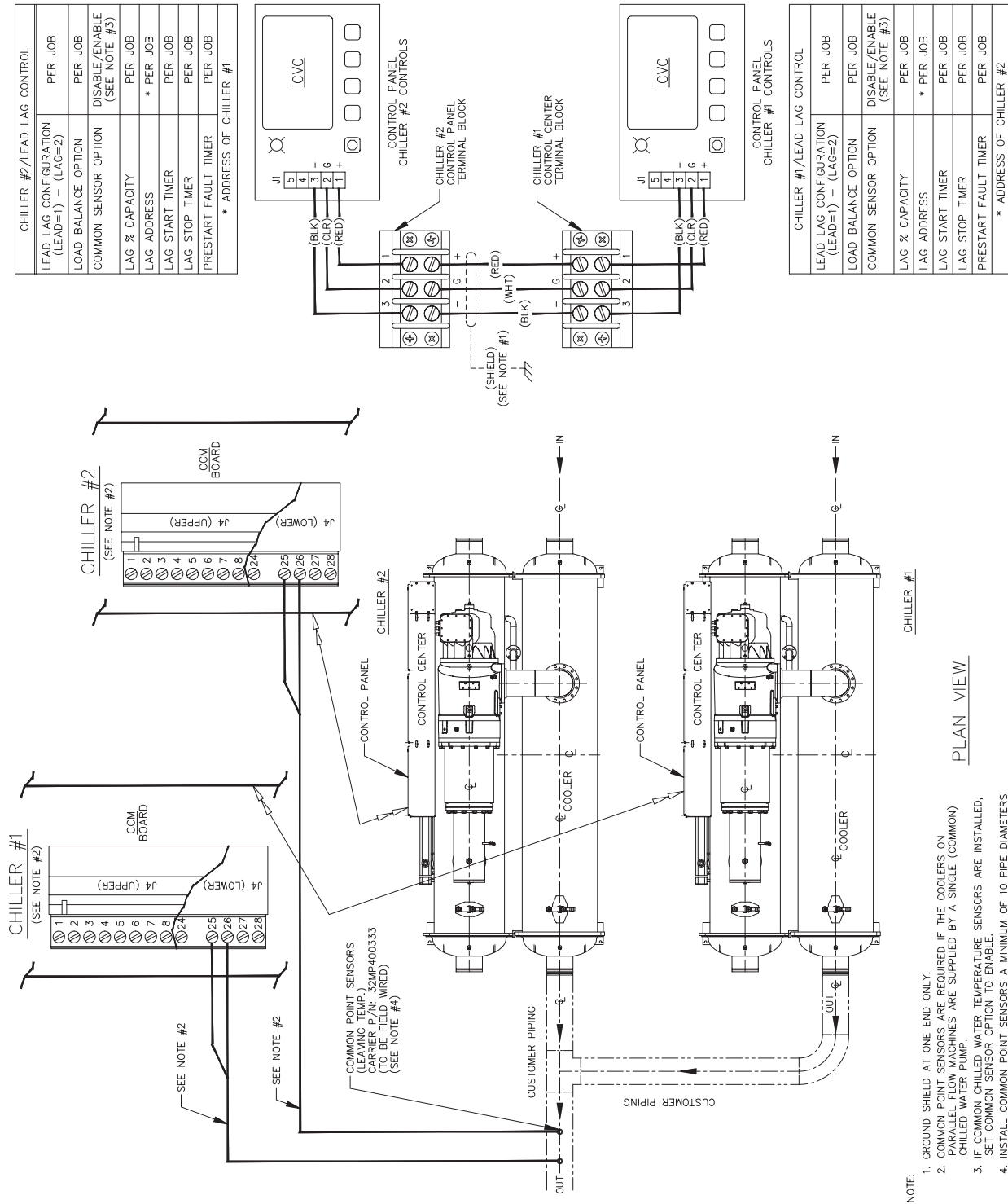
**⚠ CAUTION**

Protect insulation from weld heat damage and weld splatter. Cover with wet canvas cover during water piping installation.

When installing insulation at the job site, insulate the following components:

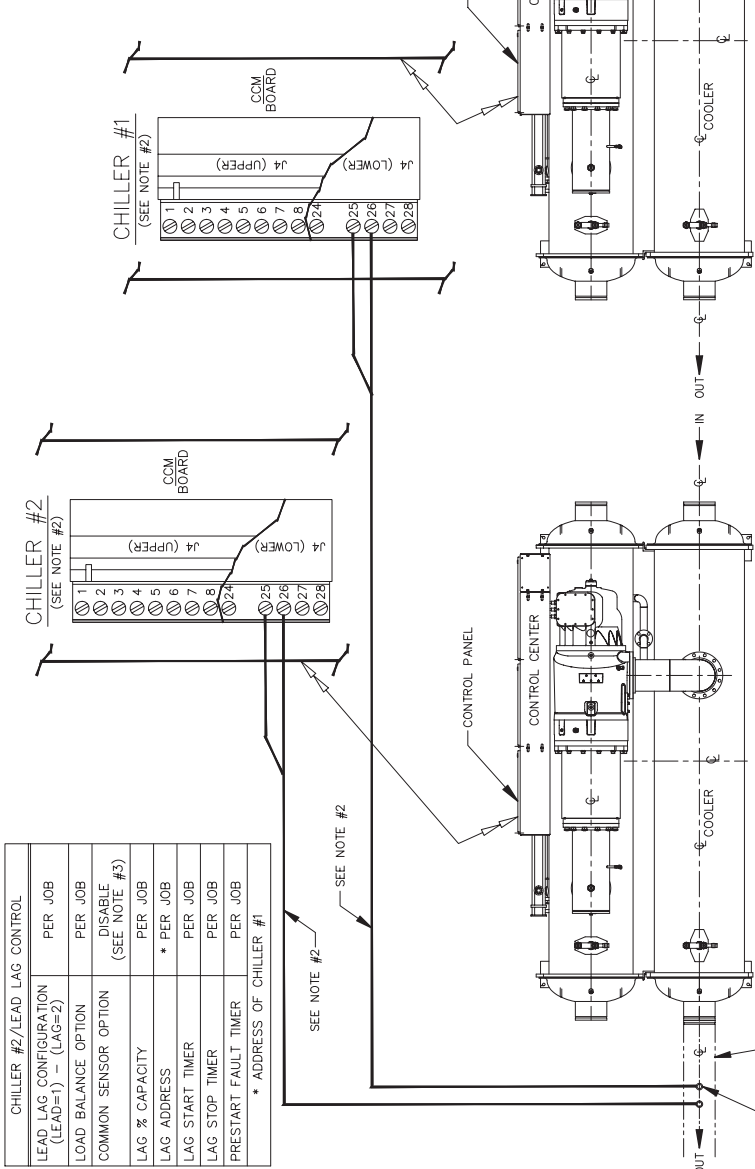
- compressor
- discharge pipe assembly
- cooler shell
- cooler tube sheets
- condenser shell
- condenser tubesheets
- suction piping
- economizer
- economizer muffler
- motor cooling drain
- oil reclaim piping
- vaporizer chamber
- refrigerant liquid line to cooler

NOTE: Insulation of the waterbox covers is applied only at the job site by the contractor. When insulating the covers, make sure there is access for removal of waterbox covers for servicing (Fig. 54).



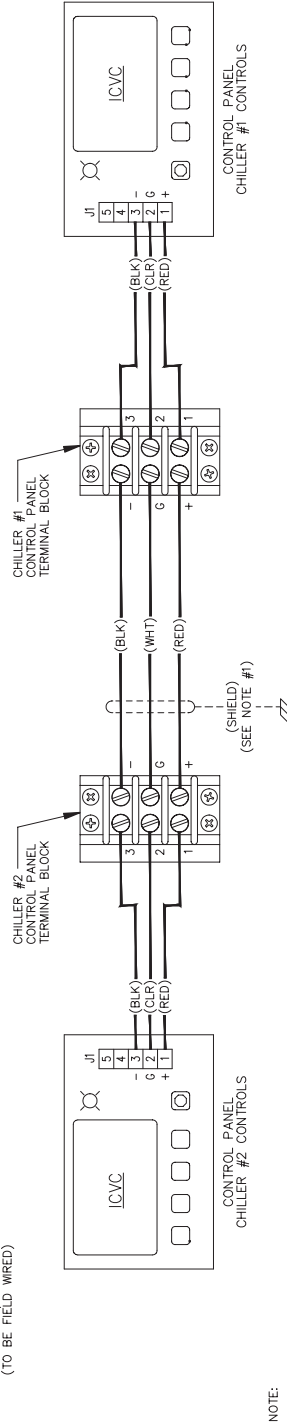
**Fig. 53 — Lead/Lag Control Wiring**

CHILLER #1/LEAD LAG CONTROL	
LEAD LAG CONFIGURATION (LEAD=1) - (LAG=2)	PER JOB
LOAD BALANCE OPTION	PER JOB
COMMON SENSOR OPTION	DISABLE (SEE NOTE #3)
LAG % CAPACITY	PER JOB
LAG ADDRESS	* PER JOB
LAG START TIMER	PER JOB
LAG STOP TIMER	PER JOB
PRESTART FAULT TIMER	PER JOB
* ADDRESS OF CHILLER #2	



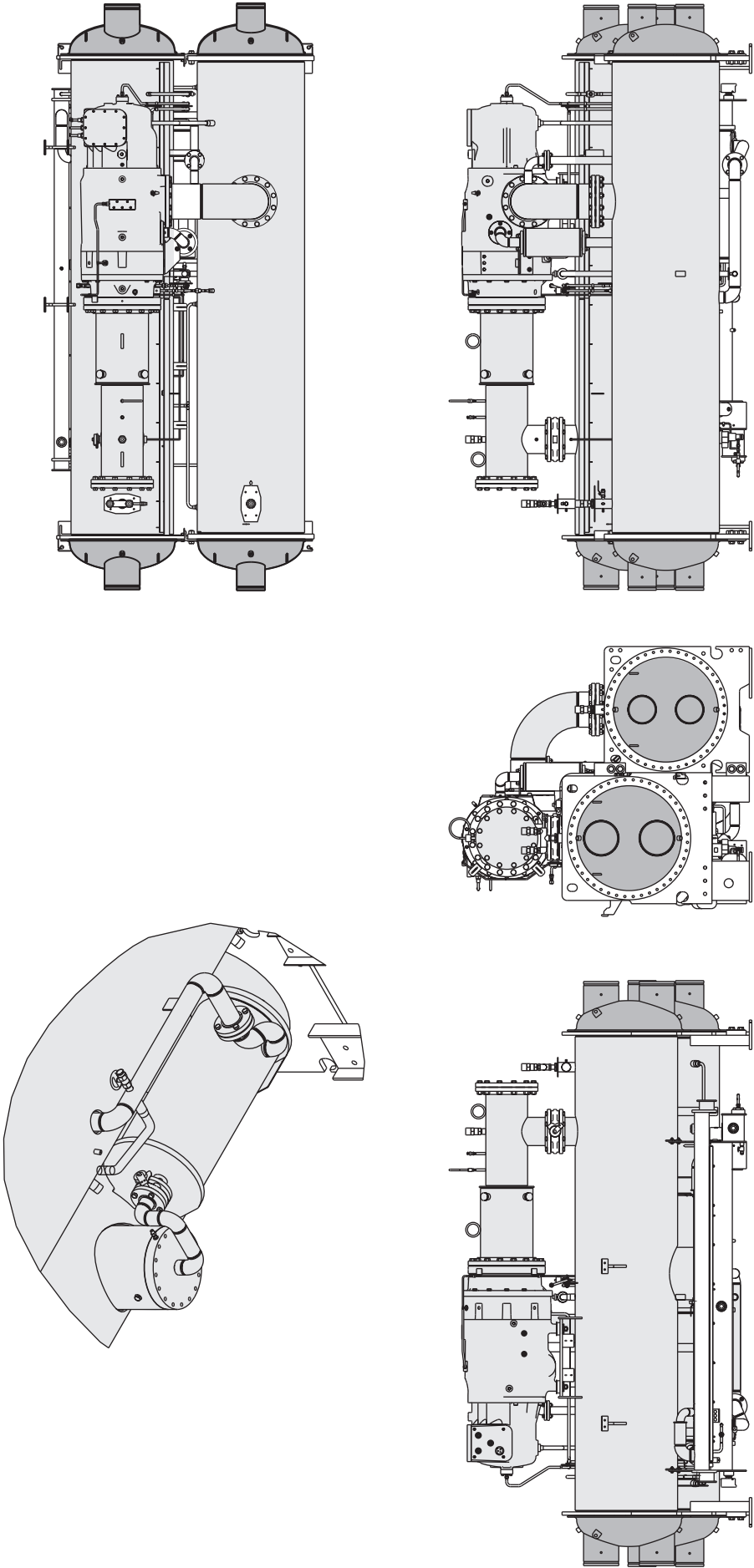
CHILLER #1  
PLAN VIEW

CHILLER #2  
PLAN VIEW



- NOTE:
1. GROUND SHIELD AT ONE END ONLY.
  2. COMMON SENSORS ARE REQUIRED TO ALTERNATE THE LEAD AND LAG CHILLERS IN SERIES FLOW APPLICATIONS.
  3. IF COMMON CHILLED WATER TEMPERATURE SENSORS ARE INSTALLED, SET COMMON SENSOR OPTION TO ENABLE.

Fig. 53 — Lead/Lag Control Wiring (cont)



FACTORY-INSTALLED INSULATION

FACTORY-SUPPLIED AND INSTALLED INSULATION (IF REQUIRED)

**Fig. 54 — 23XRV Insulation Area**







## INSTALLATION START-UP REQUEST CHECKLIST

Machine Model Number: 23XRV Serial Number: \_\_\_\_\_

To: \_\_\_\_\_  
 \_\_\_\_\_  
 \_\_\_\_\_

Attn.: \_\_\_\_\_

Date \_\_\_\_\_

Project Name \_\_\_\_\_

Carrier Job Number \_\_\_\_\_

The following information provides the status of the chiller installation. Send a copy of this checklist to the local Carrier Service office after it has been completed and signed-off by the Purchaser and Job Site Supervisor.

	YES/NO (N/A)	DATE TO BE COMPLETED
1. The machine is level within 1/2 in. end to end.	_____	_____
2. The machine components are installed and connected in accordance with the installation instructions.	_____	_____
3. The isolation package and grouting (if necessary) are installed.	_____	_____
4. The relief valves are piped to the atmosphere.	_____	_____
5. All piping is installed and supported. Direction of flow is indicated in accordance with the installation instructions and job prints.		
a. Chilled water piping	_____	_____
b. Condenser water piping	_____	_____
c. Waterbox drain piping	_____	_____
d. Pumpout unit condenser piping (if installed)	_____	_____
e. Other _____	_____	_____
6. Gages are installed as called for on the job prints required to establish design flow for the cooler and condenser.		
a. Water pressure gages IN and OUT	_____	_____
b. Water temperature gages IN and OUT	_____	_____
7. The machine's control center wiring is complete. The wiring is installed per installation instructions and certified prints.		
a. Power wiring to VFD circuit breaker. (If chiller was disassembled during installation, motor leads must not be taped until the Carrier technician megger tests the motor.)	_____	_____
b. Carrier controls can independently energize water pumps and tower fan.	_____	_____
c. Line side voltage is within ±10% of chiller nameplate voltage.	_____	_____
d. Other _____	_____	_____

COMMENTS:

\_\_\_\_\_

\_\_\_\_\_

\_\_\_\_\_

