

ITEM	PART NUMBER	QTY	PART NAME
1	111-16-73-XN	1	Run/Test Switch
2	179725-8	1	LABEL, WARNING
3	19XR04021301	1	TUBE ASY
4	19XR04021401	1	TUBE ASY.
5	19XR05023001	1	CUSTOMER GROUND
6	19XV04003201	1	DRIVE UNIT
7	19XV04003301	1	PLATE ASY
8	19XV05004802	1	VFD ASY
9	19XV05005001	1	STRIP, TERMINAL
10	19XV05005101	1	TERMINAL BLOCK
11	19XV05005201	3	TRANSFORMER-CURRENT
12	19XV05005401	1	FUSE ASY
13	19XV05005502	2	RELAY
14	19XV05005503	1	RELAY SOCKET
15	19XV05005601	1	DISCONNECT SWITCH
16	19XV05005701	1	CABLE ASY
17	19XV05005801	1	CABLE ASY
18	19XV05005901	1	CABLE ASSY
19	19XV05006001	1	CABLE ASSY
20	19XV05007201	1	TRANSFORMER
21	19XV05007501	1	CIRCUIT BREAKER
22	19XV05011501	1	LABEL, WIRING
23	19XV04003801_MU	1	CABLE-L1
24	19XV04003802_MU	1	CABLE-L2
25	19XV04003803_MU	1	CABLE-L3
26	19XV04003804_MU	1	CABLE-L4
27	19XV04003805_MU	1	CABLE-L5
28	19XV04003806_MU	1	CABLE-L6
29	19XV04003901_MU	1	GROUND CABLE
30	23XL05005303	1	LABEL
31	410267-12	1	LABEL
32	50D00032	1	LABEL-TORQUE 275 IN-LBS
33	50D00034	1	LABEL-CONDUCTORS
34	616300-243	1	NAMEPLATE, DATA
35	616300-250	1	LABEL, WARNING
36	616300-253	1	LABEL-VFD ORDER CODE
37	616300-251B	1	LABEL-OIL PUMP
38	64676-75AD	3	15 AMP FUSE
39	CSE0130037	1	ISM
40	GES144FA-C-08	1	EDGING
41	GSE144FA-C	1	EDGING
42	KK71EW016	2	O-RING
43	QR09-47-625-28	1	INSULATION
44	QR09-47-625-40	1	INSULATION
45	T_B-2522	1	GLAND, CABLE
46	Z-417	1	LABEL-Z-417
52	19XV05006101	1	CONFIGURATION, VFD

THESE PARTS NUMBERS ARE
UNIQUE TO THIS BILL

179725-8
19XV05004802
19XV05005101
50D00032

ORDER CODE NUMBER:
19XVR0414300, 19XVR0414400
19XVR0414500, 19XVR0414900

UNCONTROLLED WHEN PRINTED

REV	REVISION RECORD	DATE	BY	CHK'D	APP'D	NPCA NO.
7.0	ITEM #22 WAS 19XV05010601	1/24/06	JHG	JER	CBH	195307DJ
6.0	ITEM #22 WAS 19XV05010001	5-5-06	MHW	CM	MB	196313D
5.0	ITEM #22 WAS 19XV05008101.	03-13-06	RS-I	TC	MB	195360D
4.0	ADDED ITEM #52 TO CHART.	04-04-05	SK-I	JER	CBH	195264D

DRAWING RELEASE LEVEL: PRODUCTION		Carrier A United Technologies Company	
THIRD ANGLE PROJECTION		UNLESS OTHERWISE SPECIFIED DIMENSIONS ARE IN INCHES TOLERANCES ON: 1 DEC 2 DEC 3 DEC ANG $\pm .12$ $\pm .060$ $\pm 1^\circ$	
MATERIAL	SEE PARTS LIST PER ORDER CODE NUMBER ON THIS DRAWING	AUTHORIZATION NUMBER 195307DJ	
ENGINEERING REQUIREMENTS	-	ENGINEERING	MANUFACTURING
WEIGHT: -		CBH	-- -- --
SURFACE FINISH	MFG/PURCH	DRAFTER	CHECKER
-	PURCH	JHG 1/24/06	JER 1/24/06
		CAD MODEL (INTERNAL USE ONLY) 19XV04003001 8.0	
TITLE		VFD ASY	
SIZE	DRAWING NUMBER	414 FRAME	
D	19XV04003001	REV 7.0	
		SHEET 2 OF 7	
NEXT DRAWING	SCALE	DISTRIBUTION	
-	N/A	27	

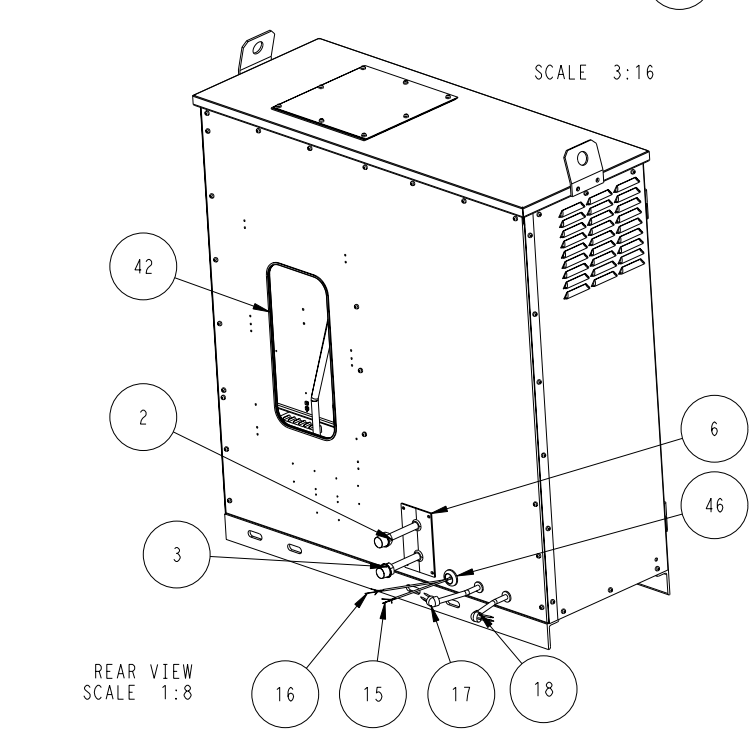
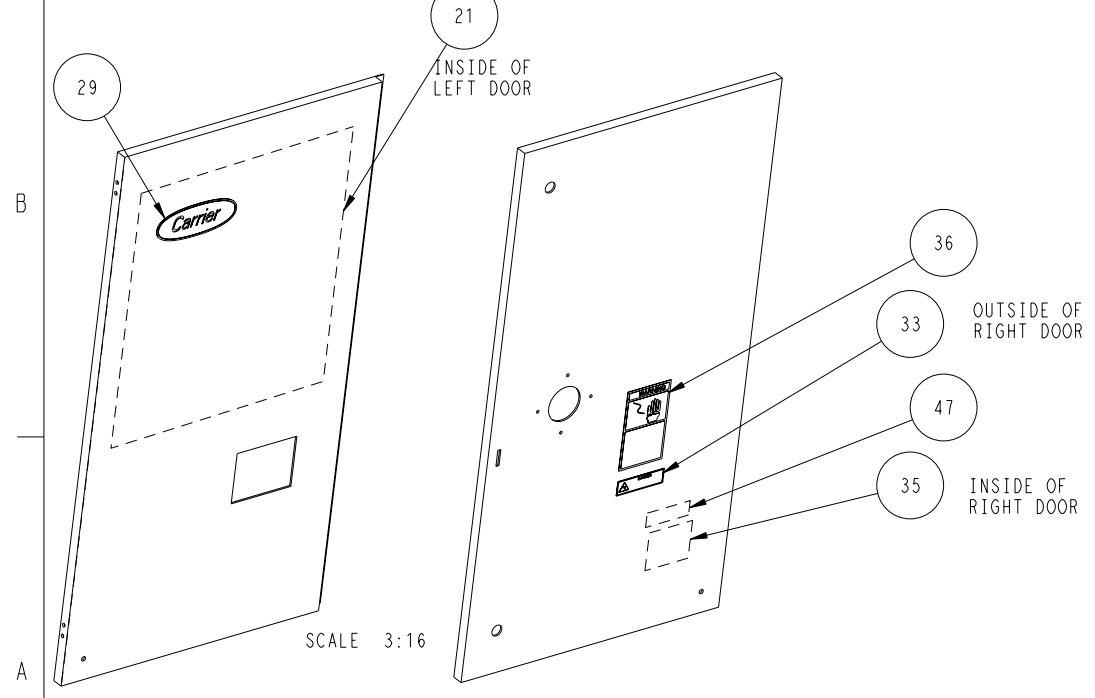
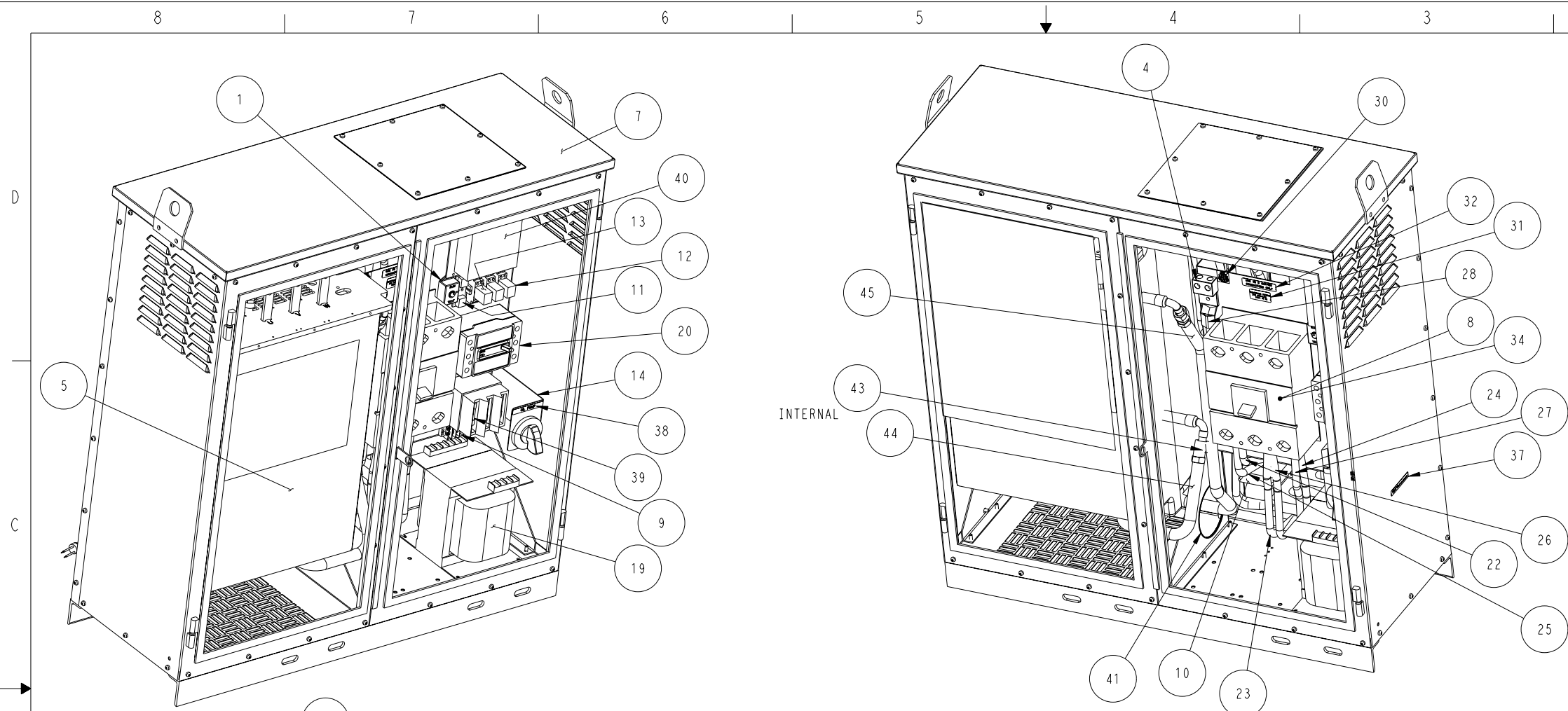

ITEM	PART NUMBER	QTY	PART NAME
1	111-16-73-XN	1	Run/Test Switch
2	19XR04021301	1	TUBE ASY
3	19XR04021401	1	TUBE ASY.
4	19XR05023001	1	CUSTOMER GROUND
5	19XV04003201	1	DRIVE UNIT
6	19XV04003301	1	PLATE ASY
7	19XV05004802	1	VFD ASY
8	19XV05004901	1	600A BREAKER
9	19XV05005001	1	STRIP, TERMINAL
10	19XV05005201	3	TRANSFORMER-CURRENT
11	19XV05005401	1	FUSE ASY
12	19XV05005502	2	RELAY
13	19XV05005503	1	RELAY SOCKET
14	19XV05005601	1	DISCONNECT SWITCH
15	19XV05005701	1	CABLE ASY
16	19XV05005801	1	CABLE ASY
17	19XV05005901	1	CABLE ASSY
18	19XV05006001	1	CABLE ASSY
19	19XV05007201	1	TRANSFORMER
20	19XV05007501	1	CIRCUIT BREAKER
21	19XV05011501	1	LABEL, WIRING
22	19XV04003801_MU	1	CABLE-L1
23	19XV04003802_MU	1	CABLE-L2
24	19XV04003803_MU	1	CABLE-L3
25	19XV04003804_MU	1	CABLE-L4
26	19XV04003805_MU	1	CABLE-L5
27	19XV04003806_MU	1	CABLE-L6
28	19XV04003901_MU	1	GROUND CABLE
29	23XL05005303	1	LABEL
30	410267-12	1	LABEL
31	50D00033	1	LABEL-TORQUE 375lb
32	50D00034	1	LABEL-CONDUCTORS
33	610293-201A	1	LABEL, WARNING
34	616300-242	1	INSULATOR
35	616300-243	1	NAMEPLATE, DATA
36	616300-250	1	LABEL, WARNING
37	616300-253	1	LABEL-VFD ORDER CODE
38	616300-251B	1	LABEL-OIL PUMP
39	64676-75AD	3	15 AMP FUSE
40	CSE0130037	1	ISM
41	GES144FA-C-08	1	EDGING
42	GSE144FA-C	1	EDGING
43	KK71EW016	2	O-RING
44	QR09-47-625-28	1	INSULATION
45	QR09-47-625-40	1	INSULATION
46	T_B-2522	1	GLAND, CABLE
47	Z-417	1	LABEL-Z-417
52	19XV05006101	1	CONFIGURATION, VFD

THESE PARTS NUMBERS ARE
UNIQUE TO THIS BILL

19XV05004802
19XV05004901
50D00033
610293-201A
616300-242

ORDER CODE NUMBER:
19XVR0414301, 19XVR0414401
19XVR0414501, 19XVR0414901

UNCONTROLLED WHEN PRINTED

REV	REVISION RECORD	DATE	BY	CHK'D	APP'D	NPCA NO.
7.0	ITEM #21 WAS 19XV05010601.	1/24/06	JHG	JER	CBH	195307DJ
6.0	ITEM #21 WAS 19XV05010001	5-5-06	MHW	CM	MB	196313D
5.0	ITEM #21 WAS 19XV05008101.	03-13-06	RS-I	TC	MB	195360D

DRAWING RELEASE LEVEL: PRODUCTION		Carrier A United Technologies Company	
THIRD ANGLE PROJECTION		UNLESS OTHERWISE SPECIFIED DIMENSIONS ARE IN INCHES TOLERANCES ON:	
MATERIAL		1 DEC	2 DEC
SEE PARTS LIST PER ORDER CODE NUMBER ON THIS DRAWING		±	±
ENGINEERING REQUIREMENTS		±0.12	±0.060
WEIGHT: -		ANG	±1°
SURFACE FINISH		AUTHORIZATION NUMBER	
MFG/PURCH		195307DJ	
PURCH		ENGINEERING	MANUFACTURING
		CBH	-- -- --
		DRAFTER	CHECKER
		JHG 1/24/06	JER 1/24/06
		CAD MODEL (INTERNAL USE ONLY)	
		19XV04003001 8.0	
		TITLE	
		VFD ASY	
		414 FRAME	
SIZE	DRAWING NUMBER	REV	
D	19XV04003001	7.0	
		SHEET 3 OF 7	
NEXT DRAWING		SCALE	DISTRIBUTION
		N/A	27

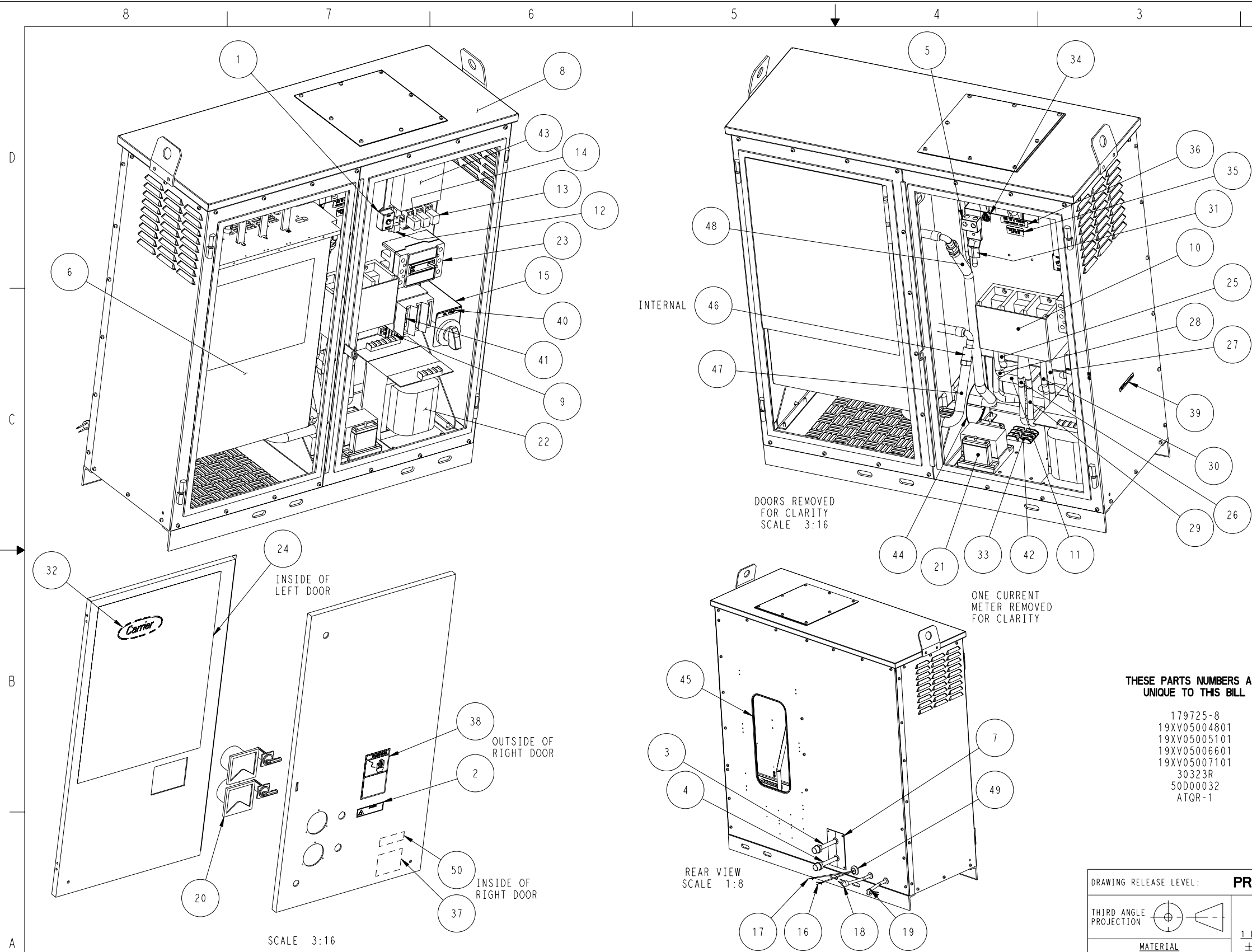

ITEM	PART NUMBER	QTY	PART NAME
1	111-16-73-XN	1	Run/Test Switch
2	179725-8	1	LABEL, WARNING
3	19XR04021301	1	TUBE ASY.
4	19XR04021401	1	TUBE ASY.
5	19XR05023001	1	CUSTOMER GROUND
6	19XV04003201	1	DRIVE UNIT
7	19XV04003301	1	PLATE ASY
8	19XV05004801	1	VFD ASY
9	19XV05005001	1	STRIP, TERMINAL
10	19XV05005101	1	TERMINAL BLOCK
11	19XV05005201	3	TRANSFORMER-CURRENT
12	19XV05005401	1	FUSE ASY
13	19XV05005502	2	RELAY
14	19XV05005503	1	RELAY SOCKET
15	19XV05005601	1	DISCONNECT SWITCH
16	19XV05005701	1	CABLE ASY
17	19XV05005801	1	CABLE ASY
18	19XV05005901	1	CABLE ASSY
19	19XV05006001	1	CABLE ASSY
20	19XV05006601	1	METER KIT
21	19XV05007101	2	POTENTIAL TRANSFORMER
22	19XV05007201	1	TRANSFORMER
23	19XV05007501	1	CIRCUIT BREAKER
24	19XV05011501	1	LABEL, WIRING
25	19XV04003801_MU	1	CABLE-L1
26	19XV04003802_MU	1	CABLE-L2
27	19XV04003803_MU	1	CABLE-L3
28	19XV04003804_MU	1	CABLE-L4
29	19XV04003805_MU	1	CABLE-L5
30	19XV04003806_MU	1	CABLE-L6
31	19XV04003901_MU	1	GROUND CABLE
32	23XL05005303	1	LABEL
33	30323R	1	FUSE BLOCK/Ferraz Shawmut
34	410267-12	1	LABEL
35	50D00032	1	LABEL-TORQUE 275 IN-LBS
36	50D00034	1	LABEL-CONDUCTORS
37	616300-243	1	NAMEPLATE, DATA
38	616300-250	1	LABEL, WARNING
39	616300-253	1	LABEL-VFD ORDER CODE
40	616300-251B	1	LABEL-OIL PUMP
41	64676-75AD	3	15 AMP FUSE
42	ATOR-1	3	1A fuse from Ferraz Shawmut
43	CSE0130037	1	ISM
44	GES144FA-C-08	1	EDGING
45	GSE144FA-C	1	EDGING
46	KK71EW016	2	O-RING
47	QR09-47-625-28	1	INSULATION
48	QR09-47-625-40	1	INSULATION
49	T_B-2522	1	GLAND, CABLE
50	Z-417	1	LABEL-Z-417
52	19XV05006101	1	CONFIGURATION, VFD

THESE PARTS NUMBERS ARE UNIQUE TO THIS BILL

179725-8
19XV05004801
19XV05005101
19XV05006601
19XV05007101
30323R
50D00032
ATOR-1

ORDER CODE NUMBER:
19XVR0414302, 19XVR0414402
19XVR0414502

REV	REVISION RECORD	DATE	BY	CHK'D	APP'D	NPCA NO.
7.0	ITEM #24 WAS 19XV05010601.	1/24/06	JHG	JER	CBH	195307DJ
6.0	ITEM #24 WAS 19XV05010001	5-5-06	MHW	CM	MB	196313D
5.0	ITEM #24 WAS 19XV05008101.	03-13-06	RS-I	TC	MB	195360D
4.0	ADDED ITEM #52 TO CHART.	04-04-05	SK-I	JER	CBH	195264D

DRAWING RELEASE LEVEL: PRODUCTION		Carrier A United Technologies Company	
THIRD ANGLE PROJECTION		UNLESS OTHERWISE SPECIFIED DIMENSIONS ARE IN INCHES TOLERANCES ON: 1 DEC 2 DEC 3 DEC ANG ±.001 ±0.12 ±.060 ±1°	
MATERIAL	SEE PARTS LIST PER ORDER CODE NUMBER ON THIS DRAWING	AUTHORIZATION NUMBER 195307DJ	
ENGINEERING REQUIREMENTS	-	ENGINEERING	MANUFACTURING
WEIGHT: -	-	JHG	JER
SURFACE FINISH	MFG/PURCH	CAD MODEL (INTERNAL USE ONLY) 19XV04003001 8.0	
TITLE VFD ASY		SIZE	414 FRAME
DRAWING NUMBER 19XV04003001		REV	7.0
SHEET 4 OF 7		NEXT DRAWING SCALE DISTRIBUTION	

UNCONTROLLED WHEN PRINTED

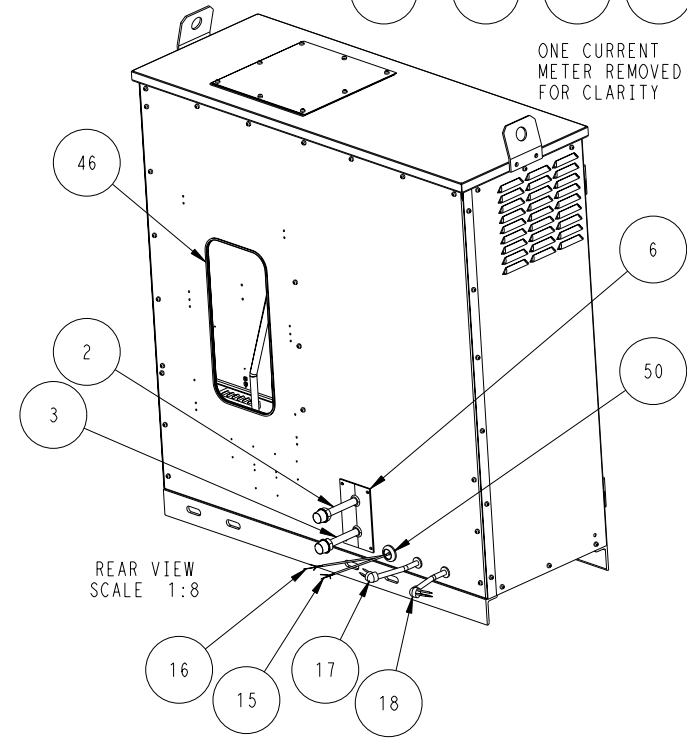
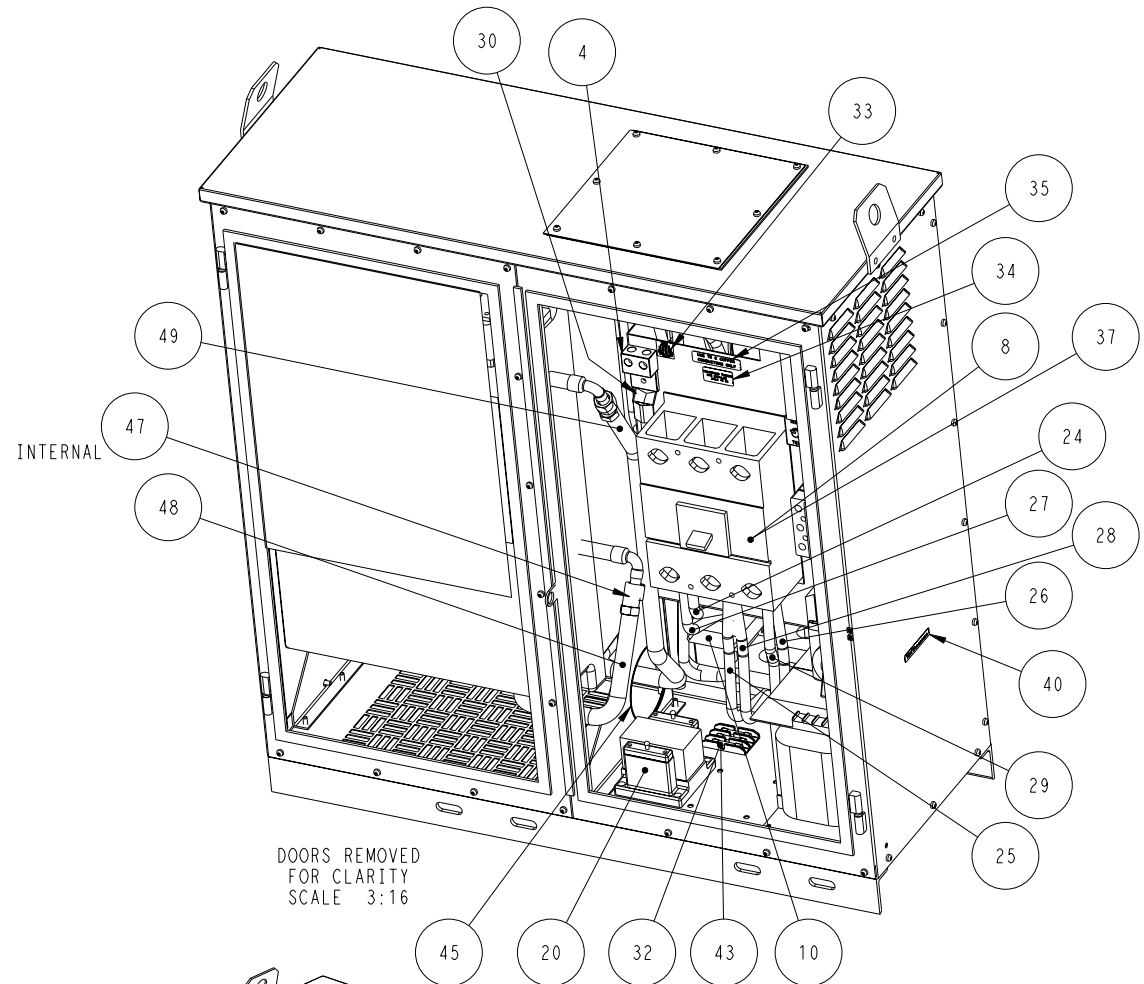
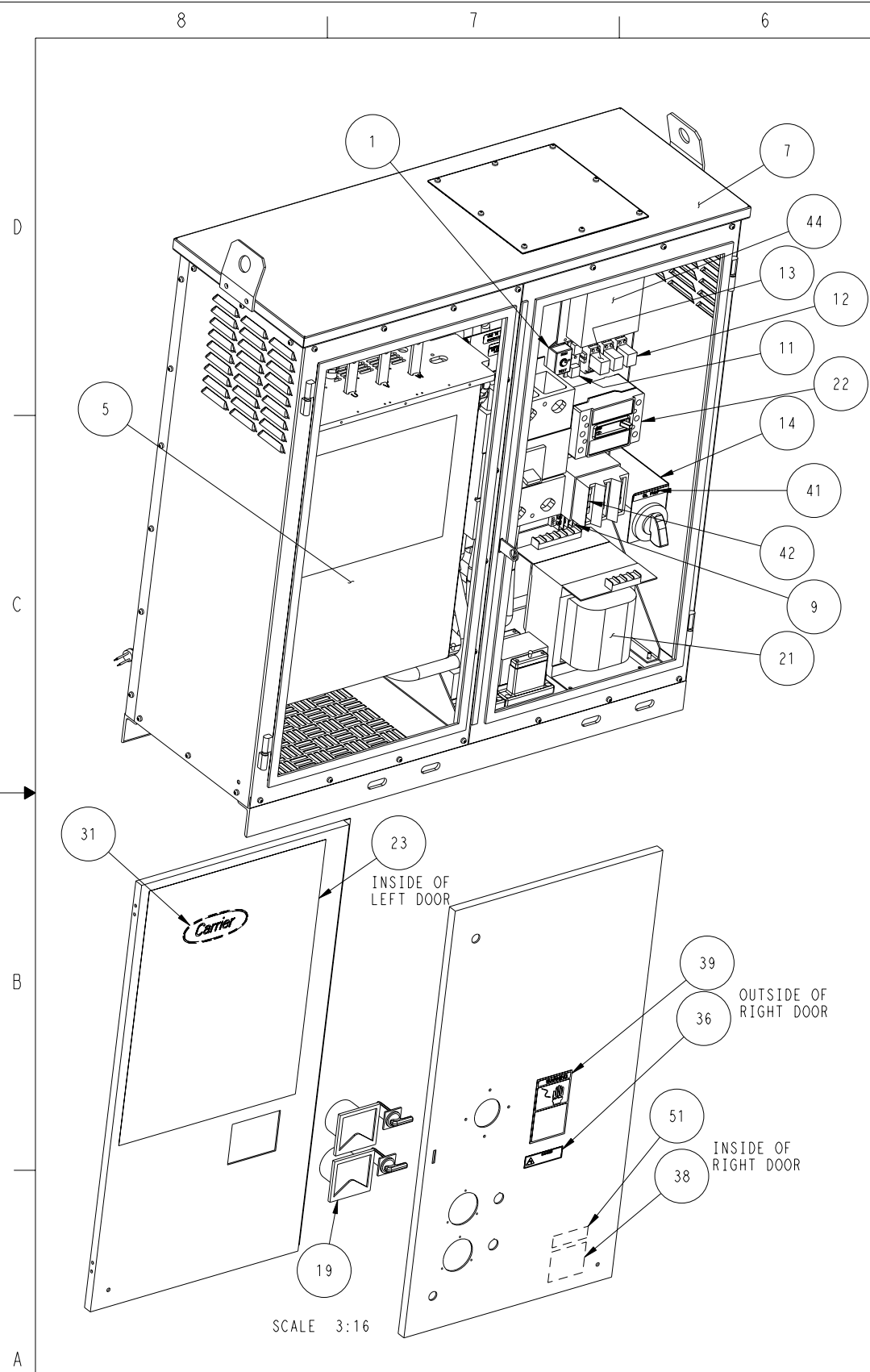

THESE PARTS NUMBERS ARE UNIQUE TO THIS BILL

19XV05004801
 19XV05004901
 19XV05006601
 19XV05007101
 30323R
 50D00033
 610293-201A
 616300-242
 ATOR-1

ITEM	PART NUMBER	QTY	PART NAME
1	111-16-73-XN	1	Run/Test Switch
2	19XR04021301	1	TUBE ASY
3	19XR04021401	1	TUBE ASY.
4	19XR05023001	1	CUSTOMER GROUND
5	19XV04003201	1	DRIVE UNIT
6	19XV04003301	1	PLATE ASY
7	19XV05004801	1	VFD ASY
8	19XV05004901	1	600A BREAKER
9	19XV05005001	1	STRIP, TERMINAL
10	19XV05005201	3	TRANSFORMER-CURRENT
11	19XV05005401	1	FUSE ASY
12	19XV05005502	2	RELAY
13	19XV05005503	1	RELAY SOCKET
14	19XV05005601	1	DISCONNECT SWITCH
15	19XV05005701	1	CABLE ASY
16	19XV05005801	1	CABLE ASY
17	19XV05005901	1	CABLE ASSY
18	19XV05006001	1	CABLE ASSY
19	19XV05006601	1	METER KIT
20	19XV05007101	2	POTENTIAL TRANSFORMER
21	19XV05007201	1	TRANSFORMER
22	19XV05007501	1	CIRCUIT BREAKER
23	19XV05011501	1	LABEL, WIRING
24	19XV04003801_MU	1	CABLE-L1
25	19XV04003802_MU	1	CABLE-L2
26	19XV04003803_MU	1	CABLE-L3
27	19XV04003804_MU	1	CABLE-L4
28	19XV04003805_MU	1	CABLE-L5
29	19XV04003806_MU	1	CABLE-L6
30	19XV04003901_MU	1	GROUND CABLE
31	23XL05005303	1	LABEL
32	30323R	1	FUSE BLOCK/Ferraz Shawmut
33	410267-12	1	LABEL
34	50D00033	1	LABEL-TORQUE 3751b
35	50D00034	1	LABEL-CONDUCTORS
36	610293-201A	1	LABEL, WARNING
37	616300-242	1	INSULATOR
38	616300-243	1	NAMEPLATE, DATA
39	616300-250	1	LABEL, WARNING
40	616300-253	1	LABEL-VFD ORDER CODE
41	616300-251B	1	LABEL-OIL PUMP
42	64676-75AD	3	15 AMP FUSE
43	ATOR-1	3	1A fuse from Ferraz Shawmut
44	CSE0130037	1	ISM
45	GES144FA-C-08	1	EDGING
46	GES144FA-C-50	1	EDGING
47	KK71EW016	2	O-RING
48	QR09-47-625-28	1	INSULATION
49	QR09-47-625-40	1	INSULATION
50	T_B-2522	1	GLAND, CABLE
51	Z-417	1	LABEL-Z-417
52	19XV05006101	1	CONFIGURATION, VFD

ORDER CODE NUMBER:
 19XVR0414303, 19XVR0414403
 19XVR0414503

7.0	ITEM #23 WAS 19XV05010601.	1/24/06	JHG	JER	CBH	195307DJ
6.0	ITEM #23 WAS 19XV05010001	5-5-06	MHW	CM	MB	196313D
5.0	ITEM #23 WAS 19XV05008101.	03-13-06	RS-I	TC	MB	195360D
REV	REVISION RECORD	DATE	BY	CHK'D	APP'D	NPCA NO.

DRAWING RELEASE LEVEL: PRODUCTION		Carrier A United Technologies Company	
THIRD ANGLE PROJECTION		UNLESS OTHERWISE SPECIFIED DIMENSIONS ARE IN INCHES TOLERANCES ON: 1 DEC ±.005 2 DEC ±.003 3 DEC ±.002 ANG ±1°	
MATERIAL	SEE PARTS LIST PER ORDER CODE NUMBER ON THIS DRAWING	AUTHORIZATION NUMBER 195307DJ	
ENGINEERING REQUIREMENTS	-	ENGINEERING	MANUFACTURING
WEIGHT: -	-	CBH	-- -- --
SURFACE FINISH	MFG/PURCH	DRAFTER	CHECKER
-	PURCH	JHG 1/24/06	JER 1/24/06
		CAD MODEL (INTERNAL USE ONLY) 19XV04003001 8.0	
TITLE		VFD ASY 414 FRAME	
SIZE	DRAWING NUMBER	REV	
D	19XV04003001	7.0	
		SHEET 5 OF 7	
NEXT DRAWING	SCALE	DISTRIBUTION	
-	N/A	27	

UNCONTROLLED WHEN PRINTED

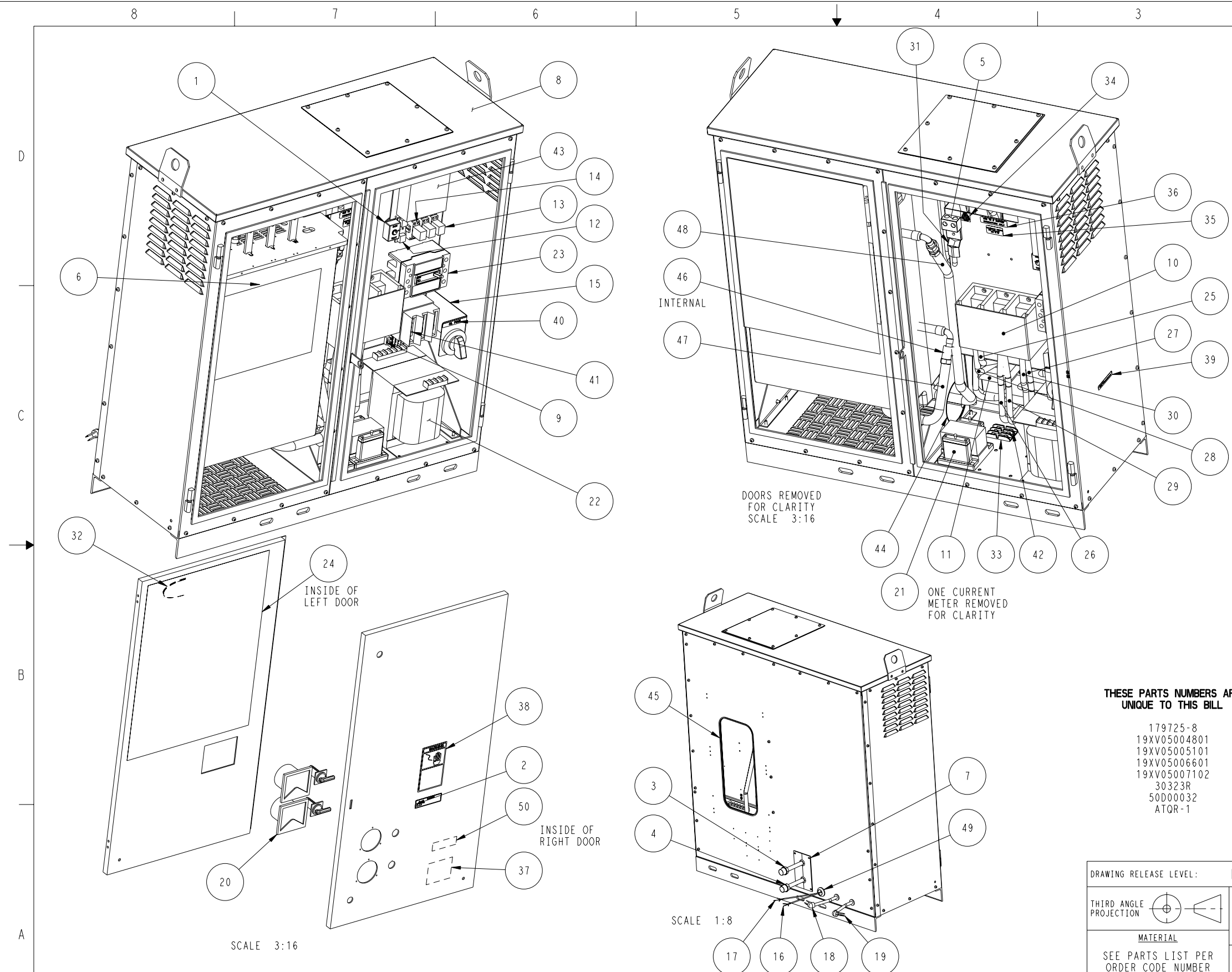

ITEM	PART NUMBER	QTY	PART NAME
1	111-16-73-XN	1	Run/Test Switch
2	179725-8	1	LABEL, WARNING
3	19XR04021301	1	TUBE ASY
4	19XR04021401	1	TUBE ASY
5	19XR05023001	1	CUSTOMER GROUND
6	19XV04003201	1	DRIVE UNIT
7	19XV04003301	1	PLATE ASY
8	19XV05004801	1	VFD ASY
9	19XV05005001	1	STRIP, TERMINAL
10	19XV05005101	1	TERMINAL BLOCK
11	19XV05005201	3	TRANSFORMER-CURRENT
12	19XV05005401	1	FUSE ASY
13	19XV05005502	2	RELAY
14	19XV05005503	1	RELAY SOCKET
15	19XV05005601	1	DISCONNECT SWITCH
16	19XV05005701	1	CABLE ASY
17	19XV05005801	1	CABLE ASY
18	19XV05005901	1	CABLE ASSY
19	19XV05006001	1	CABLE ASSY
20	19XV05006601	1	METER KIT
21	19XV05007102	2	POTENTIAL TRANSFORMER
22	19XV05007201	1	TRANSFORMER
23	19XV05007501	1	CIRCUIT BREAKER
24	19XV05011501	1	LABEL, WIRING
25	19XV04003801_MU	1	CABLE-L1
26	19XV04003802_MU	1	CABLE-L2
27	19XV04003803_MU	1	CABLE-L3
28	19XV04003804_MU	1	CABLE-L4
29	19XV04003805_MU	1	CABLE-L5
30	19XV04003806_MU	1	CABLE-L6
31	19XV04003901_MU	1	GROUND CABLE
32	23XL05005303	1	LABEL
33	30323R	1	FUSE BLOCK/Ferraz Shawmut
34	410267-12	1	LABEL
35	50D00032	1	LABEL-TORQUE 275 IN-LBS
36	50D00034	1	LABEL-CONDUCTORS
37	616300-243	1	NAMEPLATE, DATA
38	616300-250	1	LABEL, WARNING
39	616300-253	1	LABEL-VFD ORDER CODE
40	616300-251B	1	LABEL-OIL PUMP
41	64676-75AD	3	15 AMP FUSE
42	ATOR-1	3	1A fuse from Ferraz Shawmut
43	CSE0130037	1	ISM
44	GES144FA-C-08	1	EDGING
45	GSE144FA-C	1	EDGING
46	KK71EW016	2	O-RING
47	QR09-47-625-28	1	INSULATION
48	QR09-47-625-40	1	INSULATION
49	T_B-2522	1	GLAND, CABLE
50	Z-417	1	LABEL-Z-417
52	19XV05006101	1	CONFIGURATION, VFD

THESE PARTS NUMBERS ARE UNIQUE TO THIS BILL

179725-8
19XV05004801
19XV05005101
19XV05006601
19XV05007102
30323R
50D00032
ATOR-1

**ORDER CODE NUMBER:
19XVR0414902**

7.0	ITEM #24 WAS 19XV05010601.	1/24/06	JHG	JER	CBH	195307DJ
6.0	ITEM #24 WAS 19XV05010001	5-5-06	MHW	CM	MB	196313D
5.0	ITEM #24 WAS 19XV05008101.	03-13-06	RS-I	TC	MB	195360D
REV	REVISION RECORD	DATE	BY	CHK'D	APP'D	NPCA NO.

DRAWING RELEASE LEVEL: PRODUCTION		Carrier A United Technologies Company	
THIRD ANGLE PROJECTION	UNLESS OTHERWISE SPECIFIED DIMENSIONS ARE IN INCHES TOLERANCES ON: 1 DEC 2 DEC 3 DEC ANG ± .012 ± .060 ± 1°		
MATERIAL SEE PARTS LIST PER ORDER CODE NUMBER ON THIS DRAWING	AUTHORIZATION NUMBER 195307DJ		
ENGINEERING REQUIREMENTS -	ENGINEERING CBH	MANUFACTURING --	TITLE VFD ASY
WEIGHT: -	DRAFTER JHG 1/24/06	CHECKER JER 1/24/06	414 FRAME
SURFACE FINISH -	CAD MODEL (INTERNAL USE ONLY) 19XV04003001 8.0		SIZE D
MFG/PURCH PURCH	NEXT DRAWING -		DRAWING NUMBER 19XV04003001
	SCALE N/A	REV 7.0	
	DISTRIBUTION 27		SHEET 6 OF 7

UNCONTROLLED WHEN PRINTED

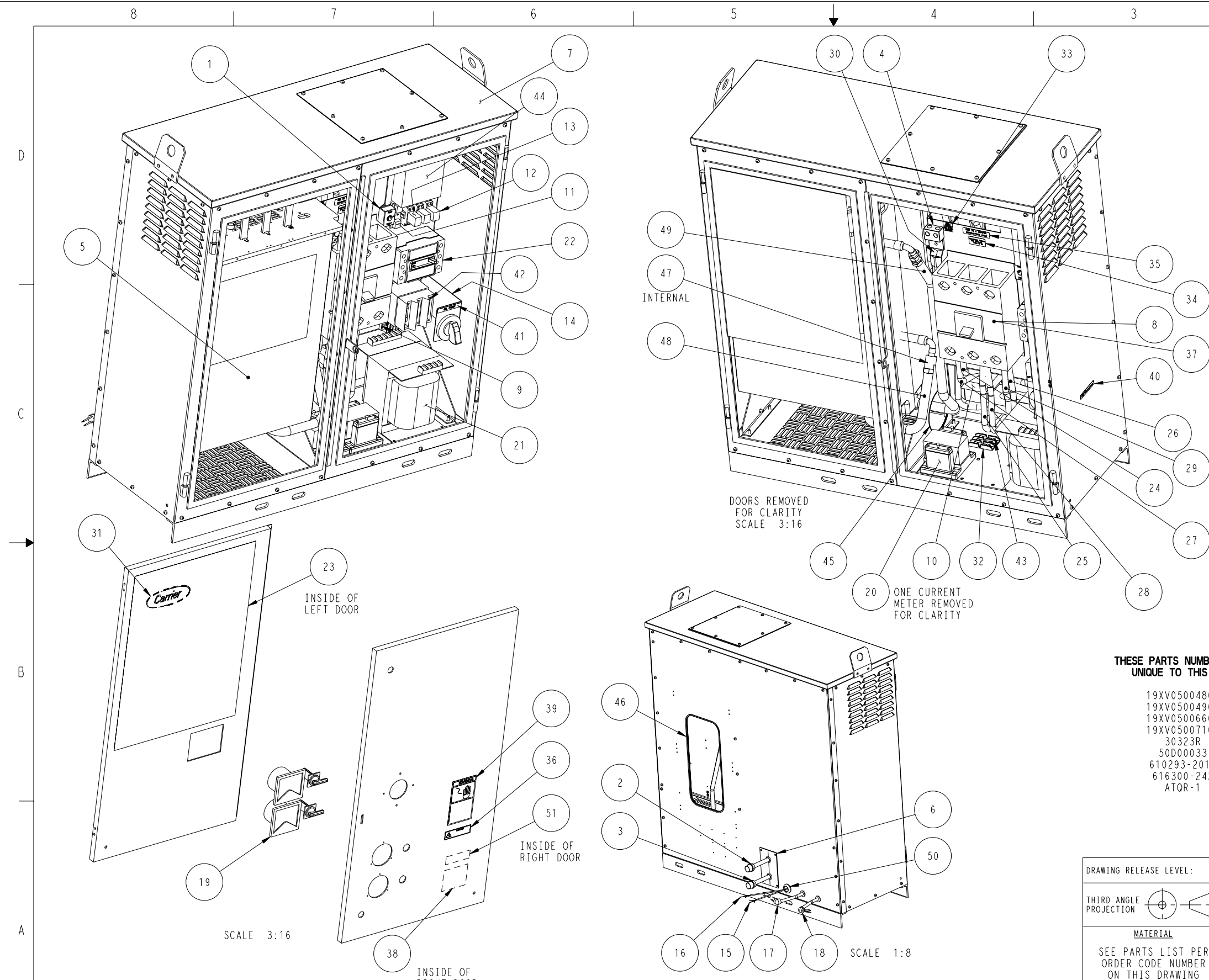

ITEM	PART NUMBER	QTY	PART NAME
1	111-16-73-XN	1	Run/Test Switch
2	19XR04021301	1	TUBE ASY
3	19XR04021401	1	TUBE ASY.
4	19XR05023001	1	CUSTOMER GROUND
5	19XV04003201	1	DRIVE UNIT
6	19XV04003301	1	PLATE ASY
7	19XV05004801	1	VFD ASY
8	19XV05004901	1	600A BREAKER
9	19XV05005001	1	STRIP, TERMINAL
10	19XV05005201	3	TRANSFORMER-CURRENT
11	19XV05005401	1	FUSE ASY
12	19XV05005502	2	RELAY
13	19XV05005503	1	RELAY SOCKET
14	19XV05005601	1	DISCONNECT SWITCH
15	19XV05005701	1	CABLE ASY
16	19XV05005801	1	CABLE ASY
17	19XV05005901	1	CABLE ASSY
18	19XV05006001	1	CABLE ASSY
19	19XV05006601	1	METER KIT
20	19XV05007102	2	POTENTIAL TRANSFORMER
21	19XV05007201	1	TRANSFORMER
22	19XV05007501	1	CIRCUIT BREAKER
23	19XV05011501	1	LABEL, WIRING
24	19XV04003801_MU	1	CABLE-L1
25	19XV04003802_MU	1	CABLE-L2
26	19XV04003803_MU	1	CABLE-L3
27	19XV04003804_MU	1	CABLE-L4
28	19XV04003805_MU	1	CABLE-L5
29	19XV04003806_MU	1	CABLE-L6
30	19XV04003901_MU	1	GROUND CABLE
31	23XL05005303	1	LABEL
32	30323R	1	FUSE BLOCK/Ferraz Shawmut
33	410267-12	1	LABEL
34	50D00033	1	LABEL-TORQUE 3751b
35	50D00034	1	LABEL-CONDUCTORS
36	610293-201A	1	LABEL, WARNING
37	616300-242	1	INSULATOR
38	616300-243	1	NAMEPLATE, DATA
39	616300-250	1	LABEL, WARNING
40	616300-253	1	LABEL-VFD ORDER CODE
41	616300-251B	1	LABEL-OIL PUMP
42	64676-75AD	3	15 AMP FUSE
43	ATQR-1	3	1A fuse from Ferraz Shawmut
44	CSE0130037	1	ISM
45	GES144FA-C-08	1	EDGING
46	GES144FA-C-50	1	EDGING
47	KK71EW016	2	O-RING
48	OR09-47-625-28	1	INSULATION
49	OR09-47-625-40	1	INSULATION
50	T_B-2522	1	GLAND, CABLE
51	Z-417	1	LABEL-Z-417
52	19XV05006101	1	CONFIGURATION, VFD

THESE PARTS NUMBERS ARE UNIQUE TO THIS BILL

- 19XV05004801
- 19XV05004901
- 19XV05006601
- 19XV05007102
- 30323R
- 50D00033
- 610293-201A
- 616300-242
- ATQR-1

**ORDER CODE NUMBER:
19XVR0414903**

UNCONTROLLED WHEN PRINTED

7.0	ITEM #23 WAS 19XV05010601.	1/24/06	JHG	JER	CBH	195307DJ
6.0	ITEM #23 WAS 19XV05010001	5-5-06	MHW	CM	MB	196313D
5.0	ITEM #23 WAS 19XV05008101.	03-13-06	RS-I	TC	MB	195360D
REV	REVISION RECORD	DATE	BY	CHK'D	APP'D	NPCA NO.

DRAWING RELEASE LEVEL: PRODUCTION		Carrier A United Technologies Company	
THIRD ANGLE PROJECTION	UNLESS OTHERWISE SPECIFIED DIMENSIONS ARE IN INCHES TOLERANCES ON: 1 DEC 2 DEC 3 DEC ANG ± .012 ± .060 ± 1°		
MATERIAL	AUTHORIZATION NUMBER 195307DJ		
SEE PARTS LIST PER ORDER CODE NUMBER ON THIS DRAWING	ENGINEERING	MANUFACTURING	TITLE VFD ASY
ENGINEERING REQUIREMENTS	CBH	-- --	414 FRAME
WEIGHT: -	DRAFTER	CHECKER	SIZE D
SURFACE FINISH	JHG 1/24/06	JER 1/24/06	DRAWING NUMBER 19XV04003001
MFG/PURCH	CAD MODEL (INTERNAL USE ONLY) 19XV04003001 8.0		SHEET 7 OF 7
PURCH	SCALE N/A	DISTRIBUTION 27	REV 7.0