

Carrier Packaged Hermetic Centrifugal Liquid Chillers

19FA
200 — 1600 Tons

The single-piece Performance Machine
for high-lift industrial use
and commercial comfort cooling

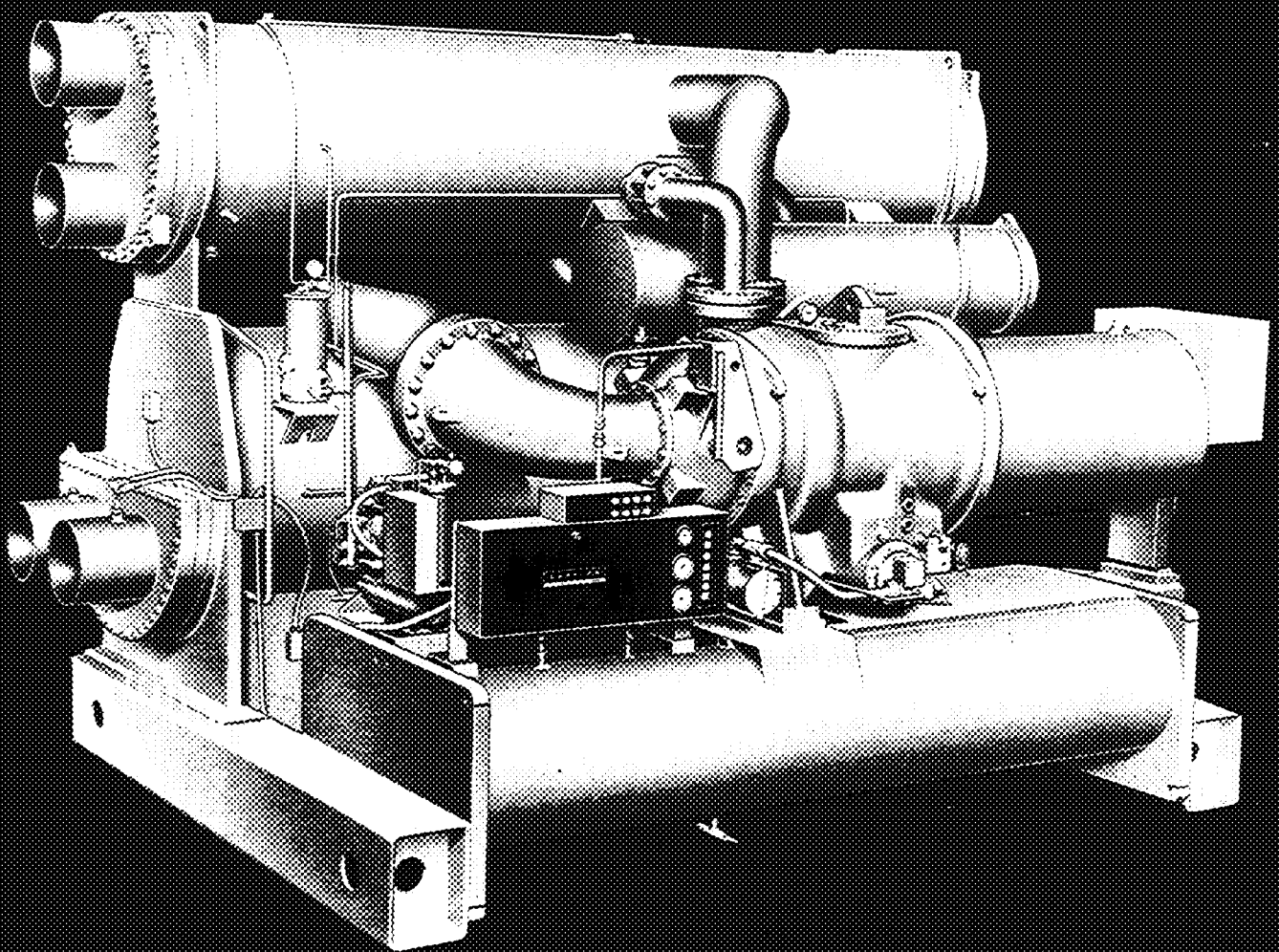

→ For the design flexibility, high-lift capability, and cost savings you've always wanted, specify

Carrier 19FA Series centrifugal chillers are today's high performance answer to the industrial and commercial refrigeration challenges associated with process cooling, comfort air conditioning, and nuclear power plant cooling applications.

As Carrier's most versatile chiller in the 200 thru 1600 ton range, the 19FA Performance Machine offers nearly unlimited flexibility for both commercial and industrial use, including water chilling service (1000 - 1600 tons) and process liquid cooling.

The 19FA unit has high-lift capability (up to 100 F), making it ideally suited to brine chilling and ice rink applications. In areas where there are cooling tower restrictions, the 19FA Performance Machine's high-lift capabilities make it suitable for use with closed circuit water condensing systems. High-lift qualifies the 19FA for an almost endless variety of industrial applications.

And Carrier's 19FA offers significant cost-saving features in every phase of the job, from easy equipment selection thru installation, day-to-day machine operation and routine maintenance, to long-range servicing programs under the auspices of the Carrier Factory Service Team.

In every area, the 19FA answers the challenge with the kind of performance you'd expect from the people who invented centrifugal refrigeration... at the kind of costs your budget can handle. Every 19FA has the rugged quality tough enough to qualify for the coveted "N" stamp for use in nuclear power plants. The 19FA is today's kind of centrifugal, a true Performance Machine.

→ Only the 19FA Performance Machine offers you these key benefits

- low wear, lowest cost, low wear installation costs
 - one-piece, factory-assembled package
 - compact, lightweight unit construction
 - integral storage tank, machine base
 - integral chilled water sensor
 - precharged, pretested
 - factory start-up
- low wear operating costs, excellent interchiller flexibility
 - high-lift capability
 - smooth, precise capacity control
 - high performance with low temperature condenser water
 - hermetic design
 - 400 rigorous quality tests on every unit
 - two separate economizer systems
- low wear maintenance and service costs
 - modular components
 - accessible internal parts
 - easily changed filters
 - Carrier's factory service organization
- highest savings cost control
 - exclusive selection and performance computer programs
- additional performance options
 - lead-lag control
 - remote control setpoint
 - safety indicator panel
 - hot gas bypass
 - thermal purge
 - pumpout unit
 - pneumatic capacity control

Lower first costs, lower installation costs

One-piece, factory assembled package

Your 19FA chiller is shipped in one piece from the factory, ready for connection to water and electrical sources at the jobsite. Save up to \$5000 on installation time and expense because there's no field assembly of components.

Compact, lightweight unit construction

Install the 19FA in a variety of sites from rooftop to basement. The compact, lightweight 19FA saves space, so the extra room may be used for other needs, or a smaller equipment room may be possible.

Integral storage tank, machine base

The 19FA storage tank is an integral part of the machine, located under the compressor, acting as a full-time support for it

and the machine control center. No more extensive refrigerant piping. At start-up, no bulky high-pressure refrigerant containers are needed: the charge is already in the storage tank when the machine leaves the factory. Permanent, integral box beam base speeds rigging, eliminates the need for costly concrete bases or supports.

Integral chilled water sensor

A chilled water thermistor probe is furnished as part of the 19FA's standard control system. A signal from this sensitive device to the control center automatically initiates immediate adjustments to compressor capacity; this eliminates the need for accessory pneumatic equipment, separate sensing devices, saves you initial equipment cost, and makes installation easier, more economical.

Precharged, pretested

Your chiller is shipped precharged and pretested with Refrigerant 12 or 500, eliminating the additional time and expense of pressure testing, dehydrating, and charging the unit after installation at the jobsite. Factory pretesting means that your unit is completely assembled at the factory by expert technicians, carefully checked and double-checked by Carrier inspectors, and fully leak tested as a complete system. And the time you save means savings in your budget too.

Factory start-up

Carrier start-up service for your 19FA is included in the purchase price, is not an extra. This assures you of a trouble-free, working installation, right from the start. It includes refrigerant transfer, leak testing and complete precision-calibrating of the solid state control settings and safety control settings.

Lower operating costs, greater machine reliability

High lift capability

The 19FA compressor has internal parts that are precision-machined to computer-designed aerodynamic contours, so that it can provide the smoothest, most efficient gas flow possible in a centrifugal compressor. The airfoil shape of the inlet guide vane gives minimal resistance to suction gas flow and permits stable operation down to 10% of full load. Impellers are precision-cast of a lightweight, high-strength aluminum alloy. The multiplicity of gear ratio combinations possible with the 19FA is computer-programmed to handle high lifts. So the 19FA has the kind of high-lift capability to make it an ideal choice for most industrial applications.

Smooth, precise capacity control

The capacity control center offers solid state compactness and reliability, with smooth and precise capacity modulation from 100% to 10% of full load. The control center provides fully automatic machine operation, complete with a full complement of safety interlocks. Check operating status at a glance, easily monitor all system operating points from a convenient, central location. The highly

sensitive thermistor probe, solid state amplifier, and guide vane actuator are precisely matched and fully responsive to changes in leaving chilled water temperature. They help to maintain your selected design temperature throughout all operating load conditions. The result is efficient, trouble-free operation with longer life. All electrical connections can be made quickly to a single terminal strip, and once the solid state control has been calibrated, control settings may be changed without additional field calibration.

Integral prearranged with low-temperature condenser water

Your 19FA centrifugal chiller is designed for efficient operation with entering condenser water temperature as low as 55 F. The ability to operate with lower temperature condenser water means correspondingly lower horsepower requirements, lower energy and operating costs. The 19FA is engineered so that flow of motor coolant, maintenance of the oil-refrigerant separation, and the metering of refrigerant is precisely and carefully matched to the machine components. This ensures a degree of pin-point efficiency of operation that allows you to

take advantage of the cost savings possible with lower temperature condenser water. You can count on the 19FA for that kind of performance.

Hermetic design

Your 19FA machine is hermetically sealed following a rigorous factory leak test. It remains free of dirt and moisture, and as an extra dividend, hermetic design helps to isolate heat from the equipment room.

ASME "N" stamp

Over the years, Carrier's quality control effort has been constantly refined and updated. A result is that the 19FA assembly and test facilities have become a model of uncompromising dedication to quality and manufacturing excellence for the industry. This excellence is manifest in the fact that the Carrier 19FA is the first hermetic centrifugal machine to qualify for the coveted ASME "N" stamp, symbolic of compliance with current regulations regarding the use of equipment in a nuclear power plant. That kind of quality is more reason than ever for you to count on Carrier for the optimum in refrigeration machine reliability.

Lower operating costs...

Two separate economizer systems

A thermal economizer in the bottom section of the condenser brings warm condensed refrigerant into contact with the inlet (coldest) water tubes. This cools the refrigerant even more, subcools it so that when it reaches the cooler, it has greater cooling potential. The overall refrigeration cycle efficiency is increased and the power/ton requirement is reduced.

A flash economizer, located between the condenser and cooler, uses the normal flashing of part of the refrigerant into gas as it goes from the condenser to the cooler to cool the remaining refrigerant. At the same time, the flash gas is diverted to the compressor second stage, so that it need not be pumped thru the full compression cycle. The net effect of the flash economizer is energy savings and lower operating costs.

→ Lower maintenance, service costs

Modular components

The 19FA control panel is easily accessible at the front of the machine. All field control wiring is made at a single terminal strip. Extra terminal contacts make the addition of field-supplied monitoring devices such as a remote indicator panel a relatively simple procedure. Every machine safety switch can be readily isolated because each is wired across its own set of terminals. One common spare part relay replaces any of the factory-supplied relays. And the capacity control module can be replaced in its entirety in a matter of minutes.

Accessible internal parts

A large inspection cover on the compressor permits easy examination of such vital parts as bearings and transmission. The float valves may be inspected by removing the float box covers on the economizer vessel. All tubes in both heat exchangers may be inspected by removal of the waterbox cover at either end of the vessel.

Easily changed filters

Shutoff valves permit quick isolation of the oil filter for removal and replacement at any time the machine is off.

Carrier's Factory Service Organization

Carrier maintains full-line centrifugal service centers in over 140 locations throughout the U.S. and Canada. More than 1000 Carrier employees are on this service "team" on call to assist you to ensure long life at maximum performance for your 19FA machine. This extraordinary full-time commitment to service is what separates Carrier from other manufacturers of centrifugal equipment. Carrier Factory Service is your assurance that your machine is in the care of people who are fully versed on the design, manufacturing, installation, start-up, and maintenance of the equipment. Why should you settle for less?

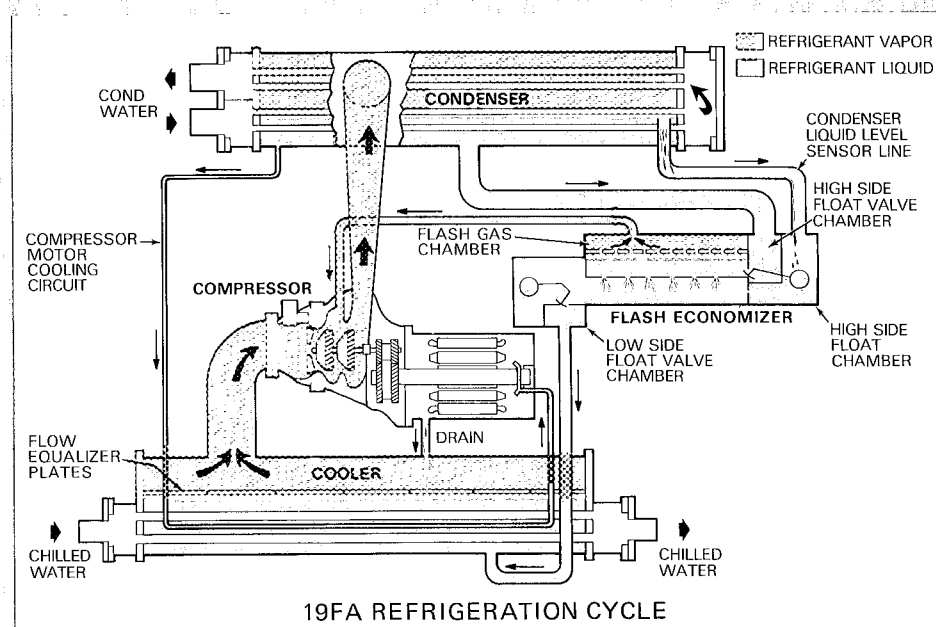
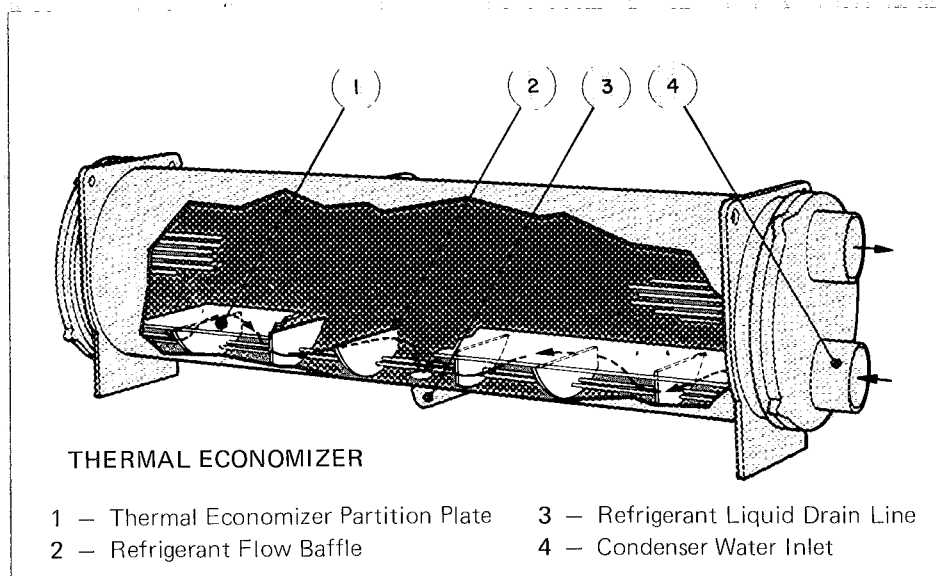

Time-saving ease of unit selection

Supplementing the ratings in this publication, Carrier has, for your convenience, developed computer selection and performance programs for 19FA units that incorporate over 20,000 combinations of condenser, compressor, and cooler components. Computerization of this data allows you to take full advantage of Carrier's tremendous job-matching flexibility and assures you of:

- unprecedented ease of selection
- comprehensive data comparing best first cost and best operating cost selections
- comparative flow rates applied to various condenser water temperatures to assist you in selecting the cooling tower
- a clear picture of how the chiller functions with the other components of your system
- accurate matching of components at full and part load
- reliable forecasting of owning and operating costs

Only Carrier offers you this truly optimized selection which is far superior to the competition's severely limited, combination manual/computer, "compromise" selection systems. With Carrier you have the ultimate in flexibility — you can specify an entering OR a leaving condenser water temperature; a temperature differential OR a water flow rate. And this unique service normally takes just overnight, and is yours completely free of charge when you select Carrier equipment.

Added convenience options

Centralized control

Desirable when 2 machines are installed in series or parallel. This centralized control permits manual or automatic starting, allows transfer of part-load recycle function from one machine to the other, alters chilled water setpoint. Panel lights indicate system operating mode.

Remote control setpoint

Select or alter chilled water temperature from a remote location by specifying this solid state control option.

Emergency indicator panel

Specify this factory-mounted and wired accessory to provide the machine operator with an instant troubleshooting capability. Seven panel lights monitor high

motor or bearing temperature, low refrigerant temperature, high condenser pressure, starter (overloads and protective features), low water flow, low oil pressure, and chilled water temperature. When safety is tripped, the light goes on. Panel does not affect the integrity of the central control system and, when ordered separately, is easily connected to the machine without disturbing factory wiring.

High gas bypass

Factory-mounted and wired; manual or automatic. Virtually eliminates compressor surging at extreme part load conditions, smooths out the machine's full operating cycle, whatever the load fluctuation.

High pressure pumpout

Factory-mounted; manual or automatic. Effectively removes air, water and non-condensables from the refrigerant system. Promotes greater operating economy and lower maintenance costs.

Pumpout unit

Factory mounted; complete with starter, controls, and all necessary interconnecting refrigerant piping. Permits easy transfer of refrigerant between machine and storage tank. Speeds servicing and minimizes downtime. On multiple machine applications, a single pumpout unit saves first costs.

Pneumatic capacity control

Available for convenient interface with existing pneumatic control systems.

SAMPLE INPUT	SAMPLE OUTPUT
Program Ident	Machine Description
Series — Model	Series — Model
Type Drive	Cooler — Cond Sizes
	Cooler — Cond Passes
Cooler	Compressor — Drive
Lvg Temp	Compressor Gear
Ent Temp	Refrigerant
Temp Diff	Chiller Base
gpm	
Tons	BHP and RPM
	Capacity (tons)
Condenser	Input bhp
Ent Temp	Input rpm
Lvg Temp	
Temp Diff	Weights
gpm	Refrig Charge
	Total Oper Weight
Optional Input	Total Rigging Weight
Cooler Size	Cooler Conditions
Cond Size	Ent Temp
Cooler Passes	Lvg Temp
Cond Passes	gpm
Cooler Length	Pres Drop
Max Input bhp	
Input rpm	Condenser Conditions
Type Refrig	Total Heat Rej
Max Pres Drops	Lvg Temp
Max Velocities	Ent Temp
Fouling Factors	gpm
Tube Material	Pres Drop
Tube Wall Thk	
W/B Oper Pres	Costs
Type Brine	Annual Owning
Brine Concentrations	Annual Operating
	Annual Own and Oper
Optional Cost Input	Optional Output
Amortization Period	As required to match optional input.
Interest Rate	
Tax and Ins Rate	
Cost of Extra Items	
Chiller Operating Rate	
Chiller Load Factor	
Power Cost	

Electrical data

Electrical data note

Listed motor voltages are design center voltages. Motors are suitable for use with system voltages as noted, and will operate satisfactorily at 10% below the minimum and at 10% above the maximum system voltage.

- 460 v – for use on 440 to 480 v systems
- 575 v – for use on 550 to 600 v systems
- 2400 v – for use on 2300 to 2500 v systems
- 4160 v – for use on 4000 to 4300 v systems

To establish electrical data for the voltage you have selected, if other than listed voltage, use the following formulas

$$FLA = \text{listed FLA} \times \frac{\text{listed voltage}}{\text{selected voltage}}$$

$$OLTA = \text{listed OLTA} \times \frac{\text{listed voltage}}{\text{selected voltage}}$$

$$LRA = \text{listed LRA} \times \frac{\text{selected voltage}}{\text{listed voltage}}$$

where FLA is full load amps per each kw input
 OLTA is overload trip amps per each kw input
 LRA is locked rotor amps

EXAMPLE Find the FLA for an EC motor at 550 volts

$$FLA = 1.10 \times \frac{575}{550} = 1.15$$

Part-load energy requirements

At part load, chiller energy requirements are affected by many variables, including degree of load, chilled water flow, condenser water flow, entering condenser water temperature, leaving chilled water temperature, and the percentage of compressor loading at design conditions.

Because of these many variables, a typical part-load curve (% Standard Rating Tons vs % Standard Rating Kw Input) may have appreciable inaccuracies when applied to a specific chiller and set of conditions. For this reason, Carrier does not recommend the use of such curves in making operating cost studies.

Instead, thru computer analysis, Carrier will provide you with accurate and detailed information on the energy requirements of your selected 19FA chiller at the expected jobsite conditions.

→ Since conditions of design load and design wet-bulb occur rather infrequently, an opportunity for significant energy savings exists over most of the chiller operating season, *if the chiller can operate at relatively low-temperature entering condenser water.*

The 19FA chiller is capable of operating with low entering condenser water temperatures. This capability assures you of both energy conservation and excellent part-load performance.

Compressor motor controller

Compressor motor controller (starter) operates from 19FA control circuit and requires special interlocks. Consult local Carrier representative before selecting controller.

Capacitors

Power factor considerations may indicate use of capacitors. Properly sized capacitors will improve power factors (see Typical Power Factors curves). Before selecting compressor motor controller (starter), consult Carrier to determine capacitor size

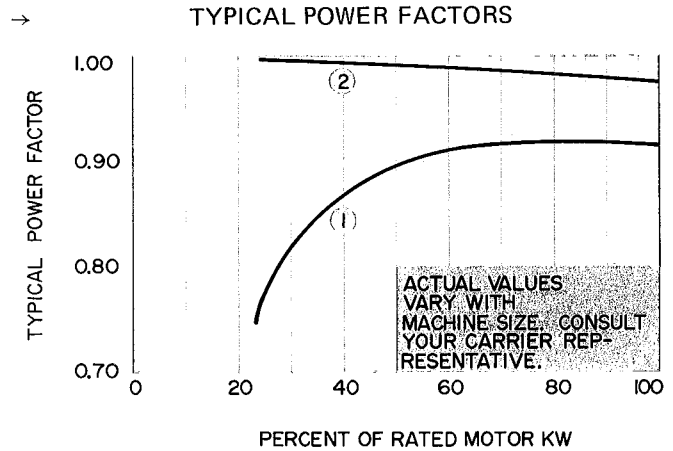

- 1 – Uncorrected Power Factor
- 2 – Max Power Factor Correction

→ Control transformer requirements

Transformers must meet the requirements of ANSI C89 1.

CONTROL CIRCUIT	ELECTRONIC		PNEUMATIC	
	Inrush	Sealed	Inrush	Sealed
	390 va	270 va	350 va	250 va
Oil Heater:	Inrush 1000 va		Sealed 1000 va	

Heater must be on separate circuit providing continuous service

→ OIL PUMP ELECTRICAL DATA (1½-Hp, 3-Phase, 60-Hz)

DESIGN CENTER VOLTAGE	SUPPLY VOLTAGE RANGE	FLA	LRA
220	200 – 240	5.2	28.2
430	380 – 480	2.6	13.8
575	550 – 600	2.1	10.7

FLA – Full Load Amps

LRA – Locked Rotor Amps

PUMPOUT COMPRESSOR ELECTRICAL DATA

HP	VOLTS	PHASE	HERTZ	FLA	LRA
2	208	3	60	8.8	48.5
	230			7.6	43.0
	460			3.8	22.5

FLA – Full Load Amps

LRA – Locked Rotor Amps

Selection procedure (with example)

→ **Selection data note**

The Selection Data tables list typical combinations of heat exchangers (HE), compressor size (CS), motor size (MS), gear and refrigerant usage (GR), and compressor power input (kw) that will effectively produce the stated refrigeration tons at the indicated condenser and chilled water temperatures

Selections have been made at commonly used design conditions of 2-pass cooler and condenser, 10 F water temperature rise and 0005 fouling factor in accordance with ARI Standard 550-74 for centrifugal chillers

Use the shaded area data in the Selection Data tables only when adjustments for pass arrangement and temperature rise place the unit selection in that area. Selections for actual chilled water temperatures below 40 F should not be made without consulting Carrier.

Maximum tonnage for any of the listed component combinations, component selections at other than the listed conditions, or component selections requiring lower input kw per ton can be obtained from Carrier's computer selection service thru your local Carrier office.

→ **I Determine design conditions**

Required capacity 1290 tons
 Leaving chilled water temperature (LCWT) . . . 45 F
 Leaving condenser water temperature (LWT) . . . 95 F
 Chilled water temperature rise 6 F
 Condenser water temperature rise 10 F
 Water quantity (cooler/condenser) . . . 5160/3740 gpm
 Fouling factor (cooler/condenser) . . . 0005/ 0005
 Pressure drop limits (cooler/condenser) . . . 15/28 ft

II Make preliminary selection of unit at a capacity equal to or higher than required capacity

Enter Selection Data table and find that

A 19FA unit producing 1300 tons at a LCWT of 45 F and a condenser LWT of 95 F has a heat exchanger combination (HE) of 2425.

III Determine number of passes for cooler and condenser in this selected unit

Enter pressure drop curves for size 24 cooler and size 25 condenser and find that at 5160 gpm (cooler), 1 pass(es) will satisfy pressure drop requirements, and at 3740 gpm (condenser), 2 pass(es) is/are satisfactory.

IV Adjust leaving water temperature for number of passes selected and for temperature rise

Enter Pass-Rise Temperature Adjustment table at 6 F rise and 1 pass (cooler) and find

45 F (LCWT) - 2.5 F = 42.5 F final LCWT

Repeating for condenser (10 F rise and 2 pass)

95 F (LWT) ± 0° F = 95 F final LWT

NOTE Round off final adjusted temperature, if required, to next lowest chilled water temperature or next highest condensing water temperature.

V Make final unit selection and determine power input (KW)

Reenter Selection Data table for 1300 tons at 42 F final LCWT and 95 F final condenser LWT and find that compressor size (CS) is 563, gear and refrigerant combination (GR) is B and 500 respectively, heat exchanger combination (HE) is 2425, motor size (MS) is EC and power input (KW) is 1093.

VI Adjust power input (KW) if the required capacity is less than the selected capacity

$$1093 \text{ KW} \times \frac{1290 \text{ tons required cap.}}{1300 \text{ tons selected cap}} = 1084 \text{ req'd kw}$$

Actual kw input may vary slightly from the estimated value. For exact kw requirement, contact your local Carrier representative.

VII Determine size of unit base - Enter step V and obtain the compressor size (CS) and the cooler size (first 2 digits of HE) Enter the Dimensions table on page 10 with this compressor-cooler combination and find the base size (S or L)

Compressor size is 563
 Cooler size is 24
 Base size is L (from page 10 table)

VIII Construct ordering number for selected unit

Refer to the ordering system below and determine that

Selected unit is 19FA563-B-500-2425-L-EC

Selection formulas

Cooler water flow (gpm) = $\frac{\text{cooling load (tons)}}{\text{temp drop}} \times 24$

Cond water flow (gpm) = $\frac{\text{cooling load (tons)}}{\text{temp rise}} \times 29$

→ **PASS-RISE TEMPERATURE ADJUSTMENT (F)**

WATER TEMP RISE	COOLER PASSES				CONDENSER PASSES			
	1	2	3	4	1	2	3	4
5	-2.0	+0.5	-	-	+2.5	0	-	-
6	-2.5	+0.5	+1.5	-	+3.0	0	-1.0	-
8	-3.5	0	+2.0	-	+3.5	0	-1.5	-
10	-4.5	0	+2.0	+3.0	+4.0	0	-1.5	-2.0
12	-5.5	0	+2.0	+3.0	+5.0	0	-1.5	-2.5
14	-6.5	0	+2.0	+3.0	+6.0	0	-2.0	-2.5
15	-	-0.5	+2.0	+3.0	+6.5	0	-2.0	-3.0
20	-	-0.5	+2.0	+3.5	-	0	-2.5	-3.5
25	-	-	+2.5	+4.0	-	-	-3.5	-4.0

NOTE: Add to (indicated by +) or subtract from (indicated by -) design leaving water temperatures per step IV of Selection Procedure

→ **Using the 19FA Model Number**

When ordering 19FA chillers, use the ordering system described below.

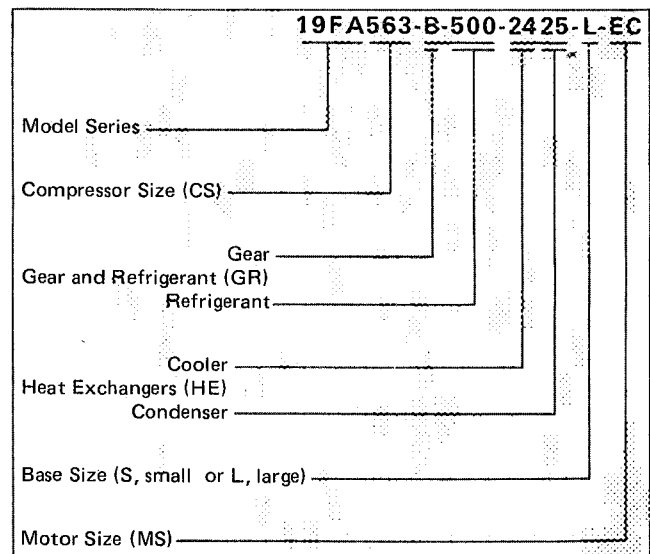

ADJ. COND TEMP
90.0
92.5
95.0
97.5
100.0
ADJ. COND TEMP
90.0
92.5
95.0
97.5
100.0
ADJ. COND TEMP
90.0
92.5
95.0
97.5
100.0

19FA Selection data

See Selection Data Note, page 6 foldout.
 HE — Heat Exchanger
 CS — Compressor Size
 KW — Kilowatt Input
 GR — Gear and Refrigerant
 MS — Motor Size

ADJ. LVG COND WTR TEMP (F)	ADJUSTED LEAVING CHILLED WATER TEMP (F)											
	38	39	40	41	42	43	44	45	46	47	48	
90.0	CS	551	565	563	541	541	541	551	551	551	555	545
	GR	8500	A 12	A 12	B500	B500	B500	A 12	A 12	A 12	A500	A500
	HE	2122	2122	2122	2122	2121	2121	2122	2122	2121	2121	2121
	MS	EA	EA	EA	EA	EA	EA	EA	EA	EA	EA	EA
	KW	836	820	790	797	798	793	729	712	702	707	692
92.5	CS	553	565	565	541	541	553	541	551	551	561	561
	GR	8500	A 12	A 12	B500	B500	A 12	B500	A 12	A 12	A 12	A 12
	HE	2122	2122	2122	2122	2122	2122	2121	2122	2122	2121	2121
	MS	EA	EA	EA	EA	EA	EA	EA	EA	EA	EA	EA
	KW	871	856	836	828	809	782	804	739	724	735	727
95.0	CS	553	553	543	551	551	541	553	553	551	551	561
	GR	8500	B500	B500	B500	B500	A 12	B500	A 12	A 12	A 12	A 12
	HE	2122	2122	2122	2122	2122	2122	2122	2122	2122	2121	2121
	MS	EA	EA	EA	EA	EA	EA	EA	EA	EA	EA	EA
	KW	885	885	874	862	854	824	795	777	754	737	746
97.5	CS	551	551	553	553	543	555	541	553	553	553	551
	GR	C500	B500	B500	B500	B500	A 12	B500	A 12	A 12	A 12	A 12
	HE	2122	2122	2122	2122	2122	2122	2122	2122	2122	2122	2122
	MS	EA	EA	EA	EA	EA	EA	EA	EA	EA	EA	EA
	KW	946	936	903	893	871	864	839	811	791	779	751
100.0	CS	551	551	555	541	553	543	543	555	555	553	553
	GR	A 12	B 12	B500	C500	B500	B500	B500	A 12	A 12	A 12	A 12
	HE	2122	2122	2122	2122	2122	2122	2122	2122	2122	2122	2122
	MS	EA	EA	EA	EA	EA	EA	EA	EA	EA	EA	EA
	KW	974	966	956	923	914	885	874	855	836	807	791

ADJ. LVG COND WTR TEMP (F)	ADJUSTED LEAVING CHILLED WATER TEMP (F)											
	38	39	40	41	42	43	44	45	46	47	48	
90.0	CS	553	561	551	551	551	551	551	551	563	563	561
	GR	8500	B500	B500	B500	B500	B500	B500	B500	A 12	A 12	A 12
	HE	2224	2224	2224	2224	2224	2224	2224	2224	2224	2224	2224
	MS	EA	EA	EA	EA	EA	EA	EA	EA	EA	EA	EA
	KW	968	940	917	906	899	895	866	859	824	806	830
92.5	CS	563	553	553	551	551	551	551	551	563	563	561
	GR	8500	B500	B500	B500	B500	B500	B500	B500	A 12	A 12	A 12
	HE	2224	2224	2224	2224	2224	2224	2224	2224	2224	2224	2224
	MS	EA	EA	EA	EA	EA	EA	EA	EA	EA	EA	EA
	KW	995	977	968	933	920	914	906	880	871	838	820
95.0	CS	551	551	553	553	551	553	553	551	551	551	561
	GR	C500	C500	B500	B500	B500	B500	B500	B500	B500	A 12	A 12
	HE	2224	2224	2224	2224	2224	2224	2224	2224	2224	2224	2224
	MS	EA	EA	EA	EA	EA	EA	EA	EA	EA	EA	EA
	KW	1024	1022	992	979	954	934	929	922	892	874	853
97.5	CS	553	561	551	553	553	553	553	551	551	551	563
	GR	C500	C500	B500	B500	B500	B500	B500	B500	B500	A 12	A 12
	HE	2224	2224	2224	2224	2224	2224	2224	2224	2224	2224	2224
	MS	EA	EA	EA	EA	EA	EA	EA	EA	EA	EA	EA
	KW	1094	1052	1036	1010	990	984	955	944	939	906	884
100.0	CS	553	553	565	551	551	553	553	553	553	551	565
	GR	C500	C500	B500	C500	C500	B500	B500	B500	B500	A 12	A 12
	HE	2224	2224	2224	2224	2224	2224	2224	2224	2224	2224	2224
	MS	EA	EA	EA	EA	EA	EA	EA	EA	EA	EA	EA
	KW	1119	1101	1093	1055	1047	1009	1002	995	964	955	925

ADJ. LVG COND WTR TEMP (F)	ADJUSTED LEAVING CHILLED WATER TEMP (F)											
	38	39	40	41	42	43	44	45	46	47	48	
90.0	CS	553	551	551	563	541	541	541	541	551	551	551
	GR	8500	B500	B500	A 12	B500	B500	B500	B500	A 12	A 12	A 12
	HE	2122	2122	2122	2122	2122	2122	2122	2222	2122	2122	2122
	MS	EA	EA	EA	EA	EA	EA	EA	EA	EA	EA	EA
	KW	888	864	859	837	836	823	814	811	737	735	724
92.5	CS	553	553	551	551	565	541	541	541	541	541	547
	GR	8500	B500	B500	B500	A 12	B500	B500	B500	B500	B500	A500
	HE	2122	2122	2122	2122	2122	2122	2122	2122	2122	2122	2122
	MS	EA	EA	EA	EA	EA	EA	EA	EA	EA	EA	EA
	KW	909	905	873	873	861	851	835	831	821	816	786
95.0	CS	551	553	553	553	551	565	541	541	553	541	551
	GR	C500	C500	B500	B500	B500	A 12	B500	B500	A 12	B500	A 12
	HE	2122	2122	2122	2122	2122	2122	2122	2122	2122	2122	2122
	MS	EA	EA	EA	EA	EA	EA	EA	EA	EA	EA	EA
	KW	961	929	919	914	879	863	867	851	824	838	773
97.5	CS	555	551	551	553	553	565	565	541	541	553	553
	GR	8500	C500	C500	B500	B500	A 12	A 12	B500	B500	A 12	A 12
	HE	2122	2122	2122	2122	2122	2122	2122	2122	2122	2122	2122
	MS	EA	EA	EA	EA	EA	EA	EA	EA	EA	EA	EA
	KW	987	971	963	935	929	900	879	869	864	834	816
100.0	CS	561	561	555	551	551	553	543	543	557	541	553
	GR	B 12	B 12	B500	C500	C500	B500	B500	A 12	B500	A 12	A 12
	HE	2122	2122	2122	2122	2122	2122	2122	2122	2122	2122	2122
	MS	EA	EA	EA	EA	EA	EA	EA	EA	EA	EA	EA
	KW	1029	1019	993	983	974	947	932	913	920	867	849

ADJ. LVG COND WTR TEMP (F)	ADJUSTED LEAVING CHILLED WATER TEMP (F)											
	38	39	40	41	42	43	44	45	46	47	48	
90.0	CS	563	553	561	551	551	551	551	551	551	563	561
	GR	8500	B500	B500	B500	B500	B500	B500	B500	B500	A 12	A500
	HE	2224	2224	2224	2224	2224	2224	2224	2224	2224	2224	2224
	MS	EA	EA	EA	EA	EA	EA	EA	EA	EA	EA	EA
	KW	1013	1001	964	956	939	933	922	914	888	889	831
92.5	CS	551	563	553	563	551	551	551	551	551	551	541
	GR	C500	B500	B500	B500	B500	B500	B500	B500	B500	B500	B500
	HE	2224	2224	2224	2224	2224	2224	2224	2224	2224	2224	2224
	MS	EA	EA	EA	EA	EA	EA	EA	EA	EA	EA	EA
	KW	1059	1029	1018	1011	967	952	946	940	930	921	903
95.0	CS	561	561	563	563	553	561	551	551	551	551	541
	GR	C500	C500	B500	B500	B500	B500	B500	B500	B500	B500	B500
	HE	2225	2224	2224	2224	2224	2224	2224	2224	2224	2224	2224
	MS	EA	EA	EA	EA	EA	EA	EA	EA	EA	EA	EA
	KW	1040	1074	1054	1035	1015	993	963	961	954	950	936
97.5	CS	553	561	551	551	553	553	553	551	551	551	551
	GR	C500	C500	C500	C500	B500	B500	B500	B500	B500	B500	B500
	HE	2225	2225	2225	2224	2224	2224	2224	2224	2224	2224	2224
	MS	EA	EA	EA	EA	EA	EA	EA	EA	EA	EA	EA
	KW	1136	1105	1078	1074	1053	1032	1019	980	968	966	962
100.0	CS	563	553	553	551	551	551	551	551	551	553	551
	GR	C500	C500	C500	C500	C500	B500	B500	B500	B500	B500	B500
	HE	2225	2225	2225	2225	2225	2224	2224	2224	2224	2224	2224
	MS	EA	EA	EA	EA	EA	EA	EA	EA	EA	EA	EA
	KW	1170	1151	1132	1095	1078	1080	1075	1036	1028	985	980

ADJ. LVG COND WTR TEMP (F)	ADJUSTED LEAVING CHILLED WATER TEMP (F)											
	38	39	40	41	42	43	44	45	46	47	48	
90.0	CS	553	551	551	551	551	541	557	557	541	541	547
	GR	8500	B500	B500	B500	B500	B500	A500	A500	B500	B500	A500
	HE	2222	2222	2222	2222	2222	2222	2222	2222	2222	2222	2222
	MS	EA	EA	EA	EA	EA	EA	EA	EA	EA	EA	EA
	KW	923	885	877	874	864	863	829	812	832	826	799
92.5	CS	551	553	551	551	551	551	541	541	541	541	551
	GR	C500	B500	B500	B500	B500	B500	B500	B500	B500	B500	A 12
	HE	2222	2224	2222	2222	2222	2222	2222	2222	2222	2222	2422
	MS	EA	EA	EA	EA	EA	EA	EA	EA	EA	EA	EA
	KW	966	933	906	892	887	880	865	863	852	845	776

ADJ. LVG COND WTR TEMP (F)	ADJUSTED LEAVING CHILLED WATER TEMP (F)											
	38	39	40	41	42	43	44	45	46	47	48	
90.0	CS	563	563	563	561	561	551	551	551	551	551	557
	GR	8500	8500	8500	8500	8500	8500	8500	8500	8500	8500	A500
	HE	2425	2425	2425	2425	2425	2425	2425	2425	2425	2425	2425
	MS	EC	EC	EC	EB	EB	EB	EB	EB	EA	EA	EA
	KW	1100	1077	1061	1022	1011	991	973	972	966	958	931
92.5	CS	561	563	563	563	561	561	551	551	551	551	551
	GR	C500	8500	8500	8500	8500	8500	8500	8500	8500	8500	8500
	HE	2425	2425	2425	2425	2425	2425	2425	2425	2425	2425	2425
	MS	EC	EC	EC	EB	EB	EB	EB	EB	EA	EA	EA
	KW	1139	1119	1093	1077	1039	1023	1009	994	983	976	970
95.0	CS	563	561	561	563	563	561	561	551	551	551	551
	GR	C500	C500	C500	B500	B500	B500	B500	B500	B500	B500	B500
	HE	2425	2425	2425	2425	2425	2425	2425	2425	2425	2425	2425
	MS	ED	EC	EC	EC	EC	EB	EB	EB	EB	EB	EB
	KW	1192	1157	1141	1112	1093	1061	1040	1028	1009	1003	992
97.5	CS	563	563	565	561	563	563	553	561	551	551	551
	GR	C500	C500	B500	C500	B500	B500	B500	B500	B500	B500	B500
	HE	2426	2425	2425	2425	2425	2425	2425	2425	2425	2425	2425
	MS	ED	ED	ED	EC	EC	EC	EC	EB	EB	EB	EB
	KW	1221	1212	1194	1158	1132	1108	1098	1056	1047	1027	1018
100.0	CS	563	563	563	561	561	551	563	563	563	551	551
	GR	C500	C500	C500	C500	C500	B500	B500	B500	B500	B500	B500
	HE	2426	2426	2426	2426	2425	2425	2425	2425	2425	2425	2425
	MS	ED	ED	ED	EC	EC	EC	EC	EC	EA	EA	EA
	KW	1264	1239	1220	1182	1177	1162	1128	1117	1110	1065	1043

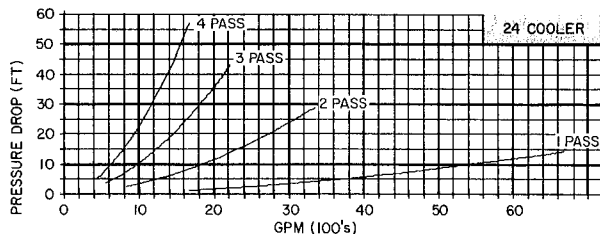
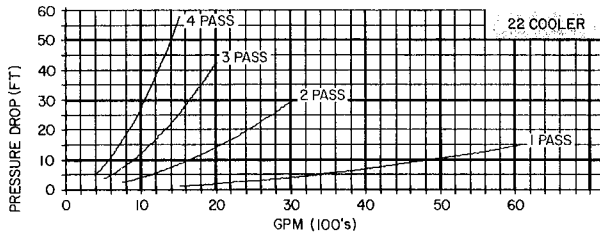
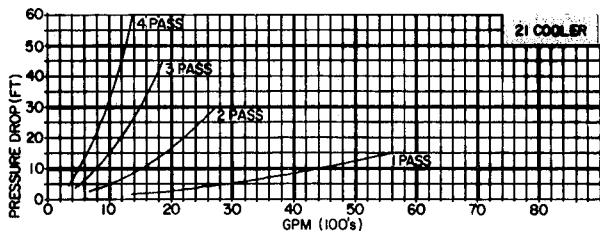
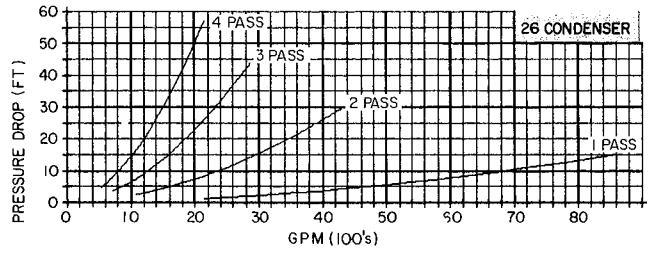
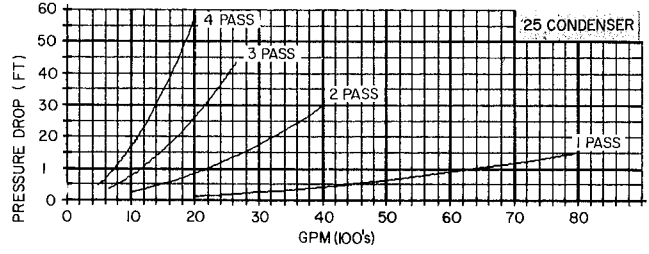
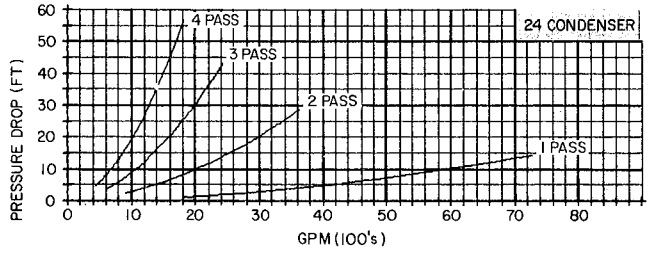
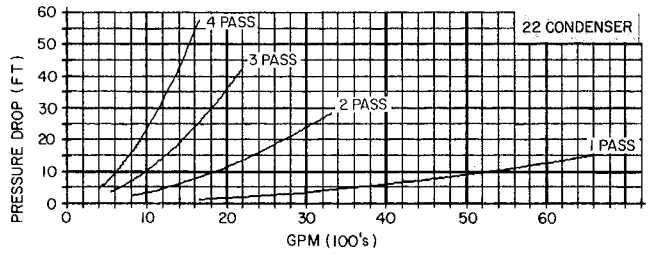
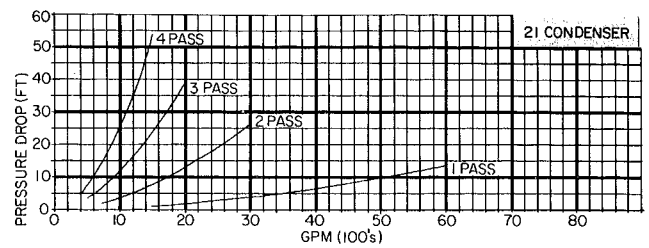

ELECTRICAL DATA

MOTOR	MAX KW	460 VOLT LRA		575 VOLT LRA		2400 VOLT LRA	4160 VOLT LRA
		Star	Delta	Star	Delta		
DM	746	1.39 FLA/KW	1.11 FLA/KW	.270 FLA/KW	.156 FLA/KW	900	519
DP	875	1.38 FLA/KW	1.10 FLA/KW	.264 FLA/KW	.153 FLA/KW	1060	613
EA	968	2250	7025	1800	5620	1346	770
EB	1080	2510	7845	2010	6275	1502	866
EC	1188	2770	8655	2218	6930	1660	958
ED	1310	3050	9540	2440	7630	1828	1053

FLA — Full Load Amps
 KW — Compressor Power Input (Kilowatts)
 LRA — Locked Rotor Amps
 NOTE: Overload Trip Amps = FLA x 1.08

PHYSICAL DATA

	HEAT EXCHANGER COMBINATION							
	2121	2122	2222	2224	2225	2422	2425	2426
RIGGING WEIGHT (lb)	35,600	35,900	37,680	38,960	39,420	39,480	42,670	43,100
OPERATING WEIGHT (lb)	37,900	38,300	40,160	41,530	42,180	42,160	45,620	46,140
OPERATING CHARGE, R-500* (lb)	2,150	2,150	2,250	2,400	2,390	2,410	2,550	2,550
AREA TO INSULATE (sq ft)	200	200	200	200	200	213	213	213

*For approximate R-12 charge, multiply by 1.2

→ 19FA Selection data

See Selection Data Note, page 6 foldout.
CS — Compressor Size
GR — Gear and Refrigerant
HE — Heat Exchanger
KW — Kilowatt Input
MS — Motor Size

ADJ. LVG COND WTR TEMP (F)	ADJUSTED LEAVING CHILLED WATER TEMP (F)										
	38	39	40	41	42	43	44	45	46	47	48
90.0	CS	563	563	561	561	561	551	551	551	551	551
	GR	8500	8500	8500	8500	8500	8500	8500	A500	8500	8500
	HE	2526	2526	2526	2526	2526	2526	2526	2525	2526	2525
	MS	EC	EC	EB	EB	EB	EB	EB	EB	EB	EB
	KW	1133	1104	1073	1049	1031	1023	1002	990	989	975
92.5	CS	561	561	563	563	561	561	551	551	551	551
	GR	C500	C500	8500	8500	8500	8500	8500	8500	8500	8500
	HE	2526	2526	2526	2526	2526	2526	2526	2526	2526	2526
	MS	EC	EC	EC	EC	EB	EB	EB	EB	EB	EB
	KW	1171	1149	1125	1101	1068	1051	1038	1017	1009	999
95.0	CS	563	561	561	563	563	561	551	551	551	551
	GR	C500	C500	C500	8500	8500	8500	8500	8500	8500	8500
	HE	2526	2526	2526	2526	2526	2526	2526	2526	2526	2526
	MS	ED	ED	EC	EC	EC	EC	EB	EB	EB	EB
	KW	1227	1184	1168	1142	1119	1084	1065	1054	1035	1024
97.5	CS	563	563	561	561	563	563	561	561	551	551
	GR	C500	C500	C500	C500	8500	8500	8500	8500	8500	8500
	HE	2526	2526	2526	2526	2526	2526	2526	2526	2526	2526
	MS	ED	ED	ED	EC	EC	EC	EC	EC	EB	EB
	KW	1271	1246	1205	1186	1163	1139	1131	1081	1074	1054
100.0	CS	563	563	563	561	563	563	563	561	561	551
	GR	C500	C500	C500	C500	8500	8500	8500	8500	8500	8500
	HE	2528	2527	2526	2526	2526	2526	2526	2526	2526	2526
	MS	ED	ED	ED	ED	ED	EC	EC	EC	EC	EB
	KW	1295	1281	1266	1224	1201	1182	1161	1146	1100	1087

ADJ. LVG COND WTR TEMP (F)	ADJUSTED LEAVING CHILLED WATER TEMP (F)											
	38	39	40	41	42	43	44	45	46	47	48	
90.0	CS	563	563	561	561	563	561	551	551	551	551	
	GR	C500	C500	C500	C500	8500	8500	8500	8500	8500	8500	
	HE	2629	2627	2627	2627	2627	2627	2627	2627	2627	2627	
	MS	ED	ED	ED	ED	ED	ED	ED	ED	ED	EB	
	KW	1307	1302	1245	1220	1195	1156	1128	1102	1091	1085	1071
92.5	CS	563	563	561	561	561	561	561	563	561	561	
	GR	C500	C500	C500	C500	8500	8500	8500	8500	8500	8500	
	HE	2929	2729	2628	2627	2627	2627	2627	2627	2627	2627	
	MS	ED	ED	ED	ED	ED	ED	ED	ED	ED	EC	
	KW	1302	1302	1282	1259	1238	1210	1174	1144	1119	1116	1101
95.0	CS	561	561	561	561	561	561	561	563	561	561	
	GR	C500	C500	C500	C500	8500	8500	8500	8500	8500	8500	
	HE	2929	2729	2628	2627	2627	2627	2627	2627	2627	2627	
	MS	ED	ED	ED	ED	ED	ED	ED	ED	ED	EC	
	KW	*	1300	1300	1295	1277	1253	1226	1187	1166	1142	1128
97.5	CS	561	561	561	561	561	561	561	563	561	561	
	GR	C500	C500	C500	C500	8500	8500	8500	8500	8500	8500	
	HE	2828	2629	2627	2627	2627	2627	2627	2627	2627	2627	
	MS	*	*	*	*	ED	ED	ED	ED	ED	EC	
	KW					1307	1297	1297	1272	1244	1210	1183
100.0	CS	561	561	561	561	563	563	563	563	563	561	
	GR	C500	C500	C500	C500	8500	8500	8500	8500	8500	8500	
	HE	2929	2729	2628	2627	2627	2627	2627	2627	2627	2627	
	MS	*	*	*	*	ED	ED	ED	ED	ED	ED	
	KW					1303	1303	1305	1293	1268	1244	1201

ADJ. LVG COND WTR TEMP (F)	ADJUSTED LEAVING CHILLED WATER TEMP (F)										
	38	39	40	41	42	43	44	45	46	47	48
90.0	CS	561	561	563	561	561	561	551	551	551	567
	GR	C500	C500	8500	8500	8500	8500	8500	8500	A500	8500
	HE	2526	2526	2526	2526	2526	2526	2526	2526	2526	2526
	MS	ED	EC	EC	EC	EC	EC	EB	EB	EB	EB
	KW	1185	1167	1146	1110	1079	1062	1051	1039	1019	1012
92.5	CS	563	561	561	563	563	561	561	561	551	551
	GR	C500	C500	C500	8500	8500	8500	8500	8500	8500	8500
	HE	2526	2526	2526	2526	2526	2526	2526	2526	2526	2526
	MS	ED	ED	EC	EC	EC	EC	EC	EB	EB	EB
	KW	1250	1205	1187	1162	1137	1099	1077	1073	1054	1034
95.0	CS	563	563	561	561	563	563	561	561	551	551
	GR	C500	C500	C500	C500	8500	8500	8500	8500	8500	8500
	HE	2526	2526	2526	2526	2526	2526	2526	2526	2526	2526
	MS	ED	ED	ED	EC	EC	EC	EC	EC	EB	EB
	KW	1293	1267	1226	1202	1181	1156	1121	1097	1085	1071
97.5	CS	563	563	563	561	563	563	561	561	561	551
	GR	C500	C500	C500	C500	8500	8500	8500	8500	8500	8500
	HE	2529	2527	2526	2526	2526	2526	2526	2526	2526	2526
	MS	ED	ED	ED	ED	ED	EC	EC	EC	EC	EC
	KW	1307	1301	1290	1245	1222	1199	1178	1139	1117	1107
100.0	CS	563	563	563	563	563	561	563	563	563	561
	GR	C500	C500	C500	C500	C500	8500	8500	8500	8500	8500
	HE	2829	2629	2529	2526	2526	2526	2526	2526	2526	2526
	MS	ED	ED	ED	ED	ED	ED	ED	ED	EC	EC
	KW	1308	1309	1301	1310	1290	1243	1223	1194	1179	1136

ADJ. LVG COND WTR TEMP (F)	ADJUSTED LEAVING CHILLED WATER TEMP (F)										
	38	39	40	41	42	43	44	45	46	47	48
90.0	CS	561	561	561	561	561	561	561	563	561	561
	GR	C500	C500	C500	C500	C500	8500	8500	8500	8500	8500
	HE	2928	2728	2627	2627	2627	2627	2627	2627	2627	2627
	MS	*	ED	ED	ED	ED	ED	ED	ED	ED	EC
	KW		1288	1289	1289	1259	1241	1205	1166	1142	1119
92.5	CS	561	561	561	561	561	561	561	563	563	561
	GR	C500	C500	C500	C500	8500	8500	8500	8500	8500	8500
	HE	2829	2728	2627	2627	2627	2627	2627	2627	2627	2627
	MS	*	*	ED	ED	ED	ED	ED	ED	ED	EC
	KW			1308	1302	1306	1278	1254	1224	1181	1154
95.0	CS	561	561	561	561	561	561	561	561	563	561
	GR	C500	C500	C500	C500	8500	8500	8500	8500	8500	8500
	HE	2929	2729	2628	2627	2627	2627	2627	2627	2627	2627
	MS	*	*	ED	ED	ED	ED	ED	ED	ED	ED
	KW			1306	1307	1306	1292	1270	1241	1194	1177
97.5	CS	561	561	561	561	561	561	561	563	563	561
	GR	C500	C500	C500	C500	8500	8500	8500	8500	8500	8500
	HE	2829	2728	2628	2627	2627	2627	2627	2627	2627	2627
	MS	*	*	*	*	ED	ED	ED	ED	ED	ED
	KW					1307	1310	1302	1288	1259	1215
100.0	CS	561	561	561	561	561	561	561	561	563	561
	GR	C500	C500	C500	C500	8500	8500	8500	8500	8500	8500
	HE	2829	2629	2529	2526	2526	2526	2526	2526	2628	2628
	MS	*	*	*	*	ED	ED	ED	ED	ED	ED
	KW					1303	1306	1293	1268	1244	1201

ADJ. LVG COND WTR TEMP (F)	ADJUSTED LEAVING CHILLED WATER TEMP (F)										
	38	39	40	41	42	43	44	45	46	47	48
90.0	CS	563	561	561	561	563	561	561	561	551	551
	GR	C500	C500	C500	C500	8500	8500	8500	8500	8500	8500
	HE	2527	2527	2527	2526	2526	2526	2526	2526	2526	2526
	MS	ED	ED	ED	EC	EC	EC	EC	EB	EB	EB
	KW	1274	1223	1199	1187	1160	1115	1093	1078	1073	1054
92.5	CS	563	563	561	561	563	563	561	561	561	551
	GR	C500	C500	C500	C500	8500	8500	8500	8500	8500	8500
	HE	2528	2527	2527	2527	2527	2526	2526	2526	2526	2526
	MS	ED	ED	ED	ED	ED	EC	EC	EC	EC	EB
	KW	1305	1289	1236	1211	1189	1166	1133	1111	1097	1084
95.0	CS	563	563	561	561	561	563	563	561	561	551
	GR	C500	C500	C500	C500	8500	8500	8500	8500	8500	8500
	HE	2729	2529	2528	2527	2527	2527	2527	2526	2526	2526
	MS	ED	ED	ED	ED	ED	ED	EC	EC	EC	EC
	KW	1301	1308	1276	1254	1232	1205	1185	1145	1129	1117
97.5</											

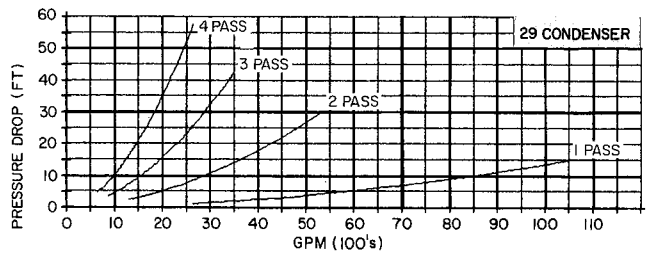
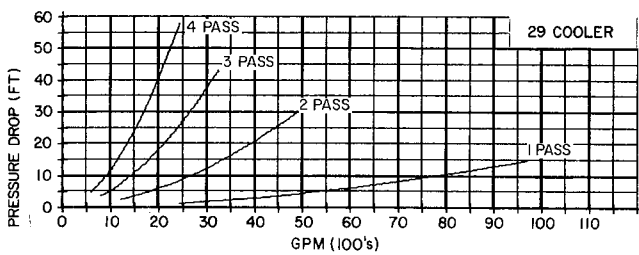
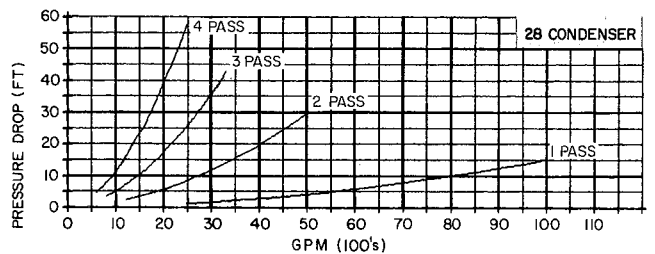
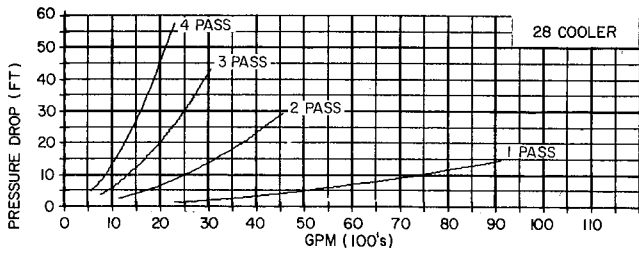
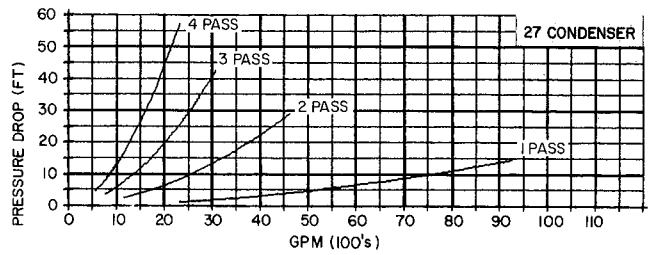
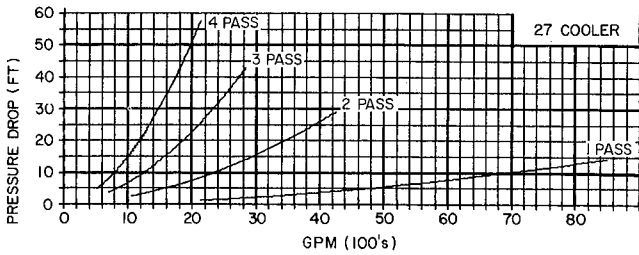
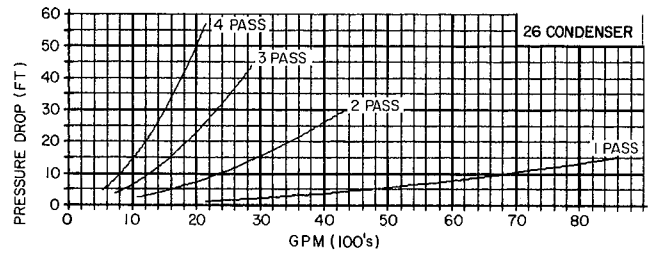
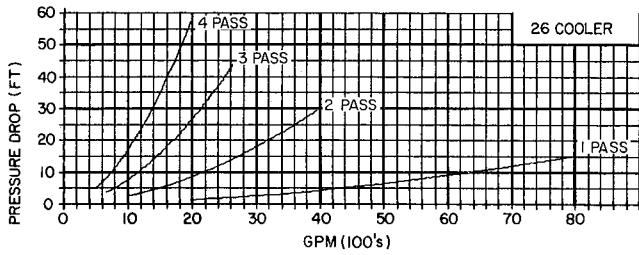
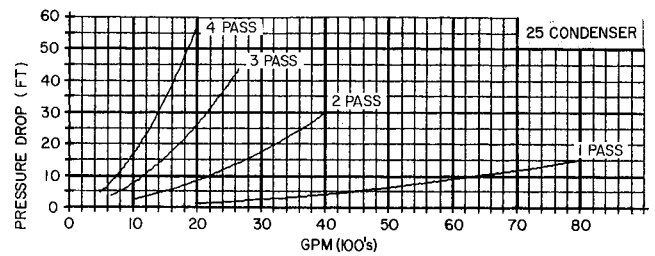
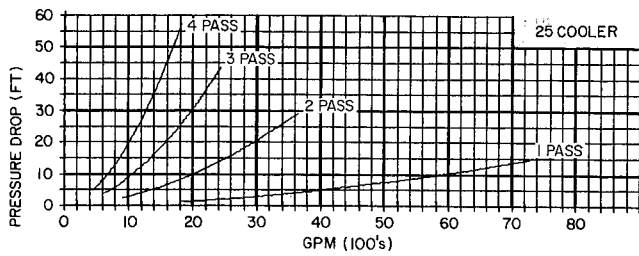

ELECTRICAL DATA

MOTOR	MAX KW	460 VOLT LRA		575 VOLT LRA		2400 VOLT LRA	4160 VOLT LRA
		Star	Delta	Star	Delta		
EB	1080	2510	7845	2010	6275	1502	866
EC	1188	2770	8655	2218	6930	1660	958
ED	1310	3050	9540	2440	7630	1828	1053

FLA — Full Load Amps
 KW — Compressor Power Input (Kilowatts)
 LRA — Locked Rotor Amps
 NOTE: Overload Trip Amps = FLA x 1.08

PHYSICAL DATA

	HEAT EXCHANGER COMBINATION													
	2525	2526	2527	2528	2529	2627	2628	2629	2728	2729	2828	2829	2929	
RIGGING WEIGHT (lb)	42,780	43,230	44,740	45,050	45,350	45,000	45,310	45,610	48,930	49,240	49,200	49,500	49,780	
OPERATING WEIGHT (lb)	45,820	46,360	47,960	48,420	48,820	48,320	48,780	49,170	52,570	52,960	52,930	53,320	53,680	
OPERATING CHARGE R-500* (lb)	2,580	2,580	2,780	2,780	2,780	2,820	2,820	2,810	3,050	3,050	3,100	3,090	3,150	
AREA TO INSULATE, (sq ft)	213	213	213	213	213	213	213	213	242	242	242	242	242	

*For approximate R-12 charge, multiply by 1.2

Dimensions

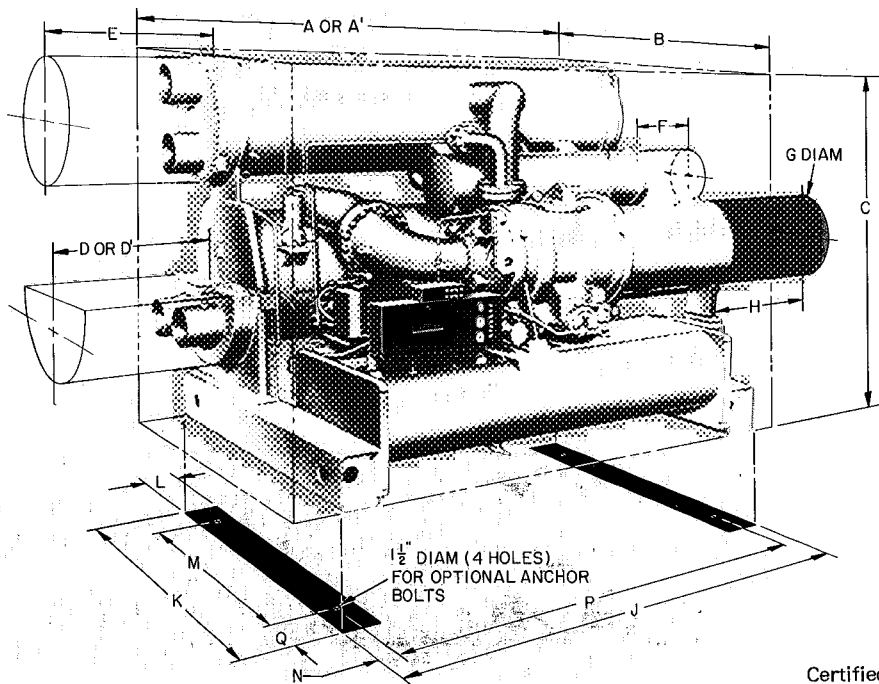

- SPACE REQUIRED FOR TUBE REMOVAL, EITHER END
- SPACE REQUIRED FOR FLOAT BOX MAINTENANCE
- SPACE REQUIRED FOR REMOVAL OF STATOR AND ROTOR
- MACHINE CONTACT SURFACE

Certified dimension drawings available upon request.

DIMENSIONS (ft-in.)

COMPR SIZE	BASE SIZE	COOLER SIZE		CONDENSER SIZE		Length*		Width B	Ht C	SPACE FOR SERVICE			
		Short	Long			TUBES				Econ F			
						Cooler D	Cond E						
421 thru 469	S	10,11,12	40,41,42	10,11,12 14,15,16	18-11 1/4	14-4 1/2	19- 0 3/4	8-6	7- 4 1/2	12-3	17-1	12-3	1-0
		14,15,16	44,45,46	10,11,12 14,15,16 18,19	7- 6 1/4								
		18,19	48,49	14,15,16 18,19	7- 2 3/4								
421 thru 569	L	20,21,22	50,51,52	20,21,22 24,25,26	19- 1 1/2	14-8 3/4	19- 6 1/2	10-0	7- 7	12-3	17-1	12-3	1-0
		24,25,26	54,55,56	18,19	7- 9								
		27,28,29	57,58,59	20,21,22 24,25,26 27,28,29	7- 9								
531 thru 569	L	24,25,26	54,55,56	20,21,22 24,25,26	19- 1 1/2	14-8 3/4	19- 6 1/2	10-0	8- 1 1/4	12-3	17-1	12-3	1-0
		27,28,29	57,58,59	18,19	8-11								
				24,25,26 27,28,29	9- 3								
				24,25,26 27,28,29					9- 8 1/4				
				24,25,26 27,28,29					9- 9 3/4				
				24,25,26 27,28,29					10- 3				
				24,25,26 27,28,29					10- 5				
				24,25,26 27,28,29					11- 0				
				27,28,29					11- 2				

*Length including nozzles on both ends. Dimensions A' and D' apply to machines with long coolers (Sizes 40 thru 59)

MACHINE CONTACT SURFACES

BASE SIZE	DIMENSIONS (ft-in.)						
	J	K	L	M	N	P	Q
S	12-11	8-6	0-8	6-6	0-4	12-3	1-0
L	13- 2 3/4	10-0	1-0	8-0	0-6	12-2 3/4	1-0

NOZZLE SIZES

COOLER SIZE	CONDENSER SIZE	NOZZLE SIZES (in.)*							
		Cooler Passes				Condenser Passes			
		1	2	3	4	1	2	3	4
10,11,12 40,41,42	10,11,12	10	6	5	5	10	8	6	5
14,15,16 44,45,46	14,15,16	10	8	6	6	12	8	6	6
18,19 48,49	18,19	12	10	8	6	14	10	8	8
20,21,22 50,51,52	20,21,22	16	10	10	8	16	12	10	8
24,25,26 54,55,56	24,25,26	18	12	10	10	18	12	10	10
27,28,29 57,58,59	27,28,29	20	14	12	10	20	14	12	10

SERVICE CLEARANCE FOR MOTORS (ft-in)

COMPR SIZE	MOTOR SIZE	SERVICE SPACE REQ'D (ft-in.)	
		G diam	H length
421 thru 469	CB - CN	1- 9	2- 7 1/4
	DB - DH	1-11 1/4	3- 2
	DK - DM	1-11 1/4	3- 7 1/2
531 thru 569	DF - DH	1-11 1/4	3- 2
	DK - DP	1-11 1/4	3- 7 1/2
	EA - ED	2- 2 3/4	3-10 1/4

*5- and 6-in nozzles are Schedule 40. 8-, 10- and 20-in nozzles are Schedule 20. 12-in nozzles are 250W, 312W or 375W. 14-, 16-, and 18-in nozzles are 312W or 375W.

Nozzle arrangements

COOLER NOZZLE NO.			ARR	CONDENSER NOZZLE NO.			ARR
Pass	In	Out		Pass	In	Out	
1	12	15	A	1	3	8	Q
	15	12	B	1	8	3	R
	11	13	C	2	5	1	S
2	13	11	D	2	10	6	T
	14	16	E	3	4	7	U
	16	14	F	3	9	2	V
3	11	14	G	4	4	2	W
	13	16	H	4	9	7	X
	14	11	J				
4	16	13	K				
	11	13	L				
	13	11	M				
	14	16	N				
	16	14	P				

Complete nozzle arrangement consists of cooler arrangement followed by condenser arrangement. For example

- 2-pass cooler — leaving nozzle no 14 = Arr F
- 1-pass cond — leaving nozzle no 3 = Arr R
- Complete nozzle arrangement = FR

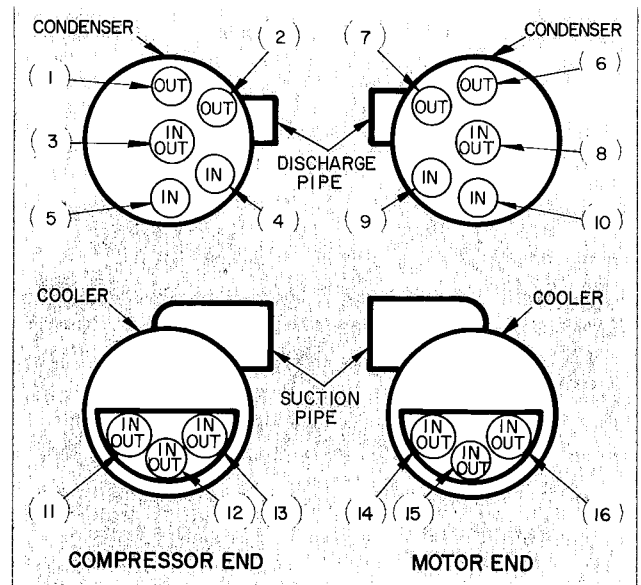

Typical piping and wiring

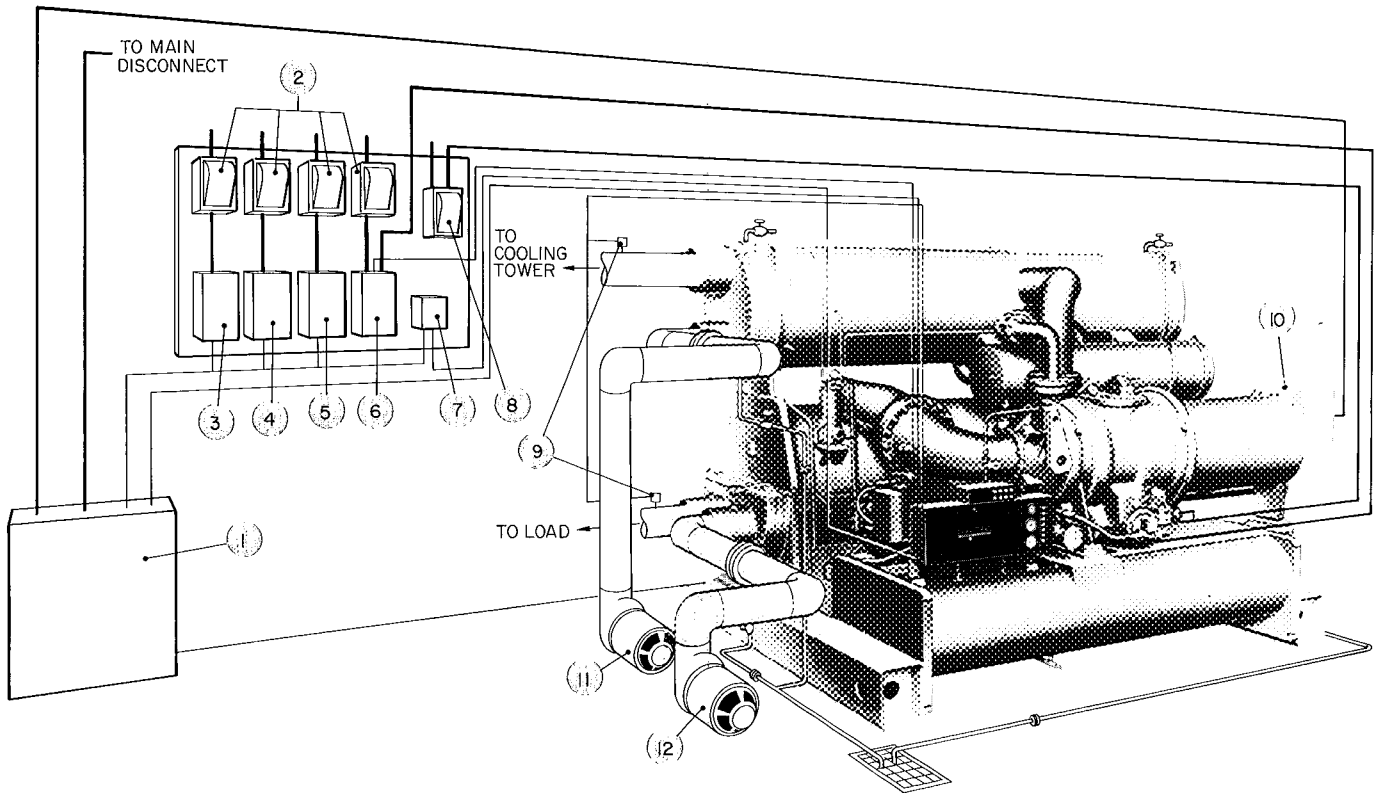

- 1 — Compressor Motor Starter
- 2 — Fused Disconnect
- 3 — Cooling Tower Fan Starter
- 4 — Condenser Water Pump Starter
- 5 — Cooler Water Pump Starter
- 6 — Lube Oil Pump Starter
- 7 — Pilot Relay
- 8 — Fused Disconnect for Oil Heater and Heater Controller (115 v)
- 9 — Water Flow Switches
- 10 — Compressor Motor Terminal Box
- 11 — Condenser Water Pump
- 12 — Cooler Water Pump

NOTES:

- 1 Separate 115-volt source for controls, unless transformer is furnished with compressor motor starter
- 2 Wiring and piping shown do not include all details for a specific installation. Refer to certified electrical drawings
- 3 Wiring must conform to applicable local and national codes
- 4 Pipe per standard techniques. See Carrier System Design Manual for details

- 5 Oil cooler water source must be clean and noncorrosive. City water or chilled water may be used. Recommended flow condition is: 30 gpm water at 85 – 100 F. Vary gpm to obtain 100 F leaving water
- 6 Oil heater must be on separate circuit providing continuous service

Controls

→ Control system

Chiller safety controls are electronic. Chiller capacity controls may be either solid state or pneumatic.

Chiller operating capacity is determined by the position of guide vanes at the entrance to the compressor suction. As cooling needs change, the vanes open and close automatically as follows

A thermistor probe in the chilled water line constantly monitors chilled water temperature. The probe signals any temperature change to a capacity control module in the machine control center. The module, in turn, initiates a response from the guide vane actuator.

When chilled water temperature drops, the vane actuator causes the guide vanes to move towards the closed position, chiller capacity decreases. Conversely, a rise in chilled water temperature causes the guide vanes to open and increase chiller capacity. If the water temperature continues to rise, the vanes open further to compensate. Built-in safeguards prevent motor overloads and, to minimize start-up demand, control interlocks keep the guide vanes closed (at minimum capacity position) until the compressor reaches run condition.

Control sequence

Before starting chiller, start condenser water pumps, chilled water pumps and cooling tower fan. Field-supplied pilot relays for this purpose should be applied as indicated in the Typical Control Wiring schematic.

Press the ON-STOP switch to energize the temperature control circuits in the compressor safety circuit and allow the chiller control circuit to be energized. If refrigerant low temperature, condenser high pressure and chilled water temperature switches are closed, the chiller control circuit may be energized by pressing the chiller START button. A program timer then executes a series of timed steps (PT-1, PT-2 and PT-3 consecutively), during which the oil pump starts and then the compressor. When the compressor starter reaches run condition, contact M closes to energize relay K3. K3 locks in control circuit power to oil pump and water pump motors whenever the compressor is operating. When relay K3 is energized, the capacity control circuit can position the compressor guide vanes as required to maintain the selected chilled water temperature.

Stop the chiller by pressing the ON-STOP button. The auxiliary water pumps and fan motor are stopped by pressing the STOP button. After compressor stop, the
→ program timer initiates a 15-minute minimum delay before restart is possible.

Control components

Condenser high-pressure cutout (manual reset) shuts compressor off if condenser pressure reaches setpoint.

Refrigerant low-temperature cutout (manual reset) protects cooler tubes from freeze-up by shutting off compressor if refrigerant temperature drops to setpoint.

Discharge and bearing temperature control circuit (manual reset) shuts compressor off if temperature reaches setpoint, and prevents compressor restart until temperature drops to acceptable level.

Motor temperature control circuit (manual reset) shuts compressor off if motor temperature reaches setpoint, prevents compressor restart until temperature drops to acceptable level.

Chilled water low-temperature cutout and recycle switch stops compressor if leaving chilled water temperature drops below setpoint. Switch automatically recycles compressor to start when water temperature rises above the differential
→ setpoint and program timer has completed 15-minute cycle.

Oil low-temperature cutout prevents compressor start until oil pressure has reached satisfactory level, automatically stops compressor if oil pressure falls to setpoint.

→ **Vane-closed switch (electronic control only)** prevents compressor start unless guide vanes are closed, ensures low-load starting.

→ **Capacity control module (electronic control only)** amplifies and modulates input from temperature sensing element in the leaving chilled water line. Solid state module then signals guide vane actuator to position guide vanes as required to match chiller load. When there is a possibility of motor overload, a motor current control within the module overrides the chilled water temperature input and closes the guide vanes.

Guide vane actuator (electric or pneumatic) positions guide vanes in response to signals from capacity control module.

Program timer sequences the start of oil pump and compressor motor to ensure adequate lubrication before compressor start, throughout compressor operation, and during the coasting period at shutdown. The timer also provides a 15-minute delay between compressor stop and restart for protection of the motor.

Motor start relay (1CR) energizes the compressor motor controller at start-up and acts as a holding relay for the compressor motor. When compressor shuts down, a normally closed 1CR contact allows program timer to begin the chiller stop-to-restart delay cycle.

Time-delay relay prevents compressor start for at least 10 seconds after oil pressure has been established, ensures that all running gear is fully lubricated at start-up.

Relay K3 (capacity control circuit) permits capacity control module to open the guide vanes only during compressor operation. Other K3 contacts act as holding relays for water pumps and compressor oil pump.

Elapsed time indicator registers and displays the actual machine running time in hours and tenths to 100,000 hours.

→ Typical control schematic

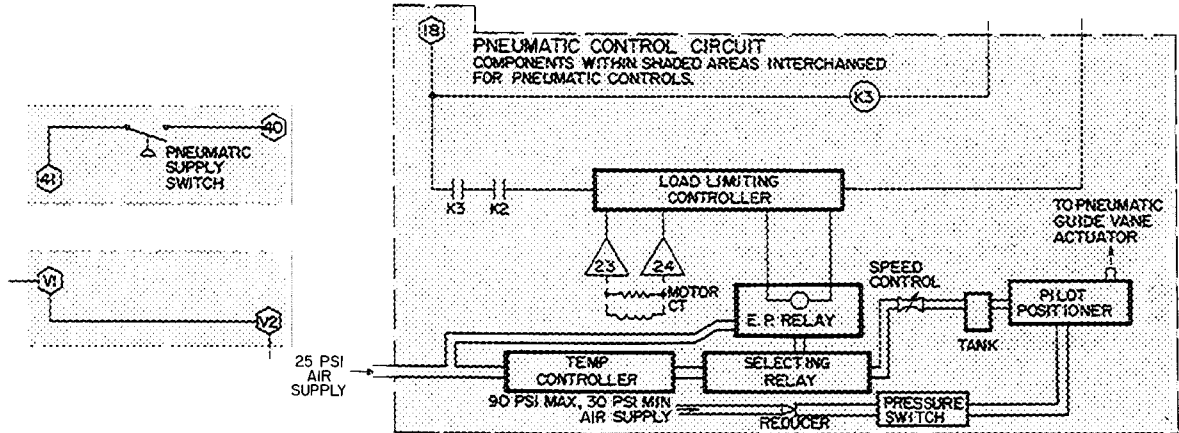
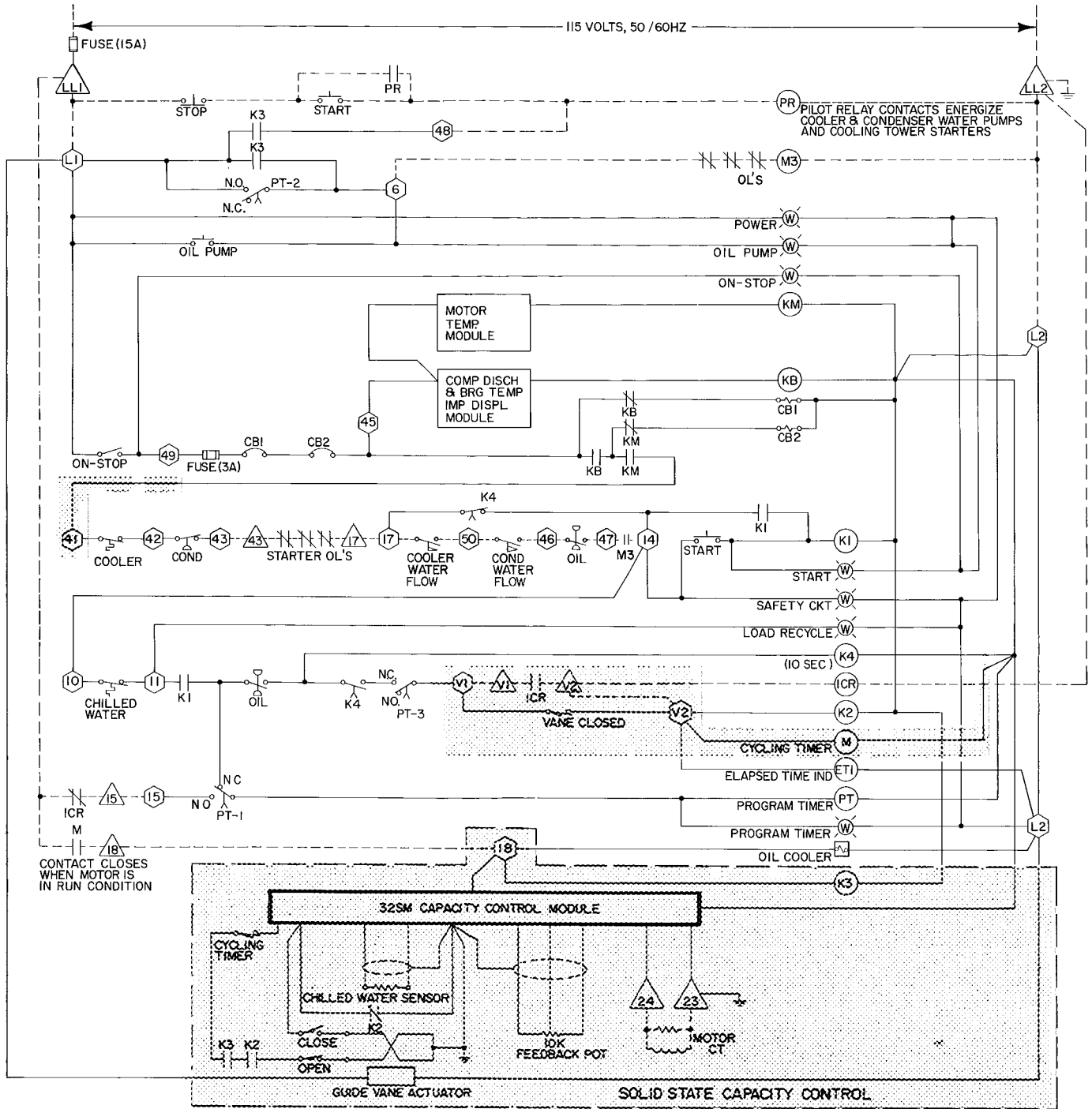

Technical support data

Compressor

The 2-stage, hermetic centrifugal compressor is furnished with variable inlet guide vanes to ensure stable operation, without surge, cavitation or undue vibration, from full load to 10% of full load, without hot gas bypass, when supplied with design entering water quantity

The compressor shaft and impeller assembly, and the rotor, shaft and bull gear assembly are both statically and dynamically balanced. There is no critical speed within the compressor operating range.

The transmission is an integral part of the compressor and is lubricated thru the compressor lubrication system. It is a 2-section, helical herringbone transmission, symmetrical and center supported by a spherically seated, self-aligning bearing. The bearing and the gears are accessible for inspection by removing an access cover.

The compressor lubrication system is of the forced lubrication type with an electrically-driven pump plus an oil cooler and filter. Pressure lubrication of bearings and seal is provided at start-up, during operation and at coastdown. The seal and bearings are also adequately protected against damage from loss of lubrication during coastdown as a result of power failure.

The 4 journal bearings are steel-backed, babbitted, split sleeve type bearings and are accessible for inspection and replacement. To contain any unbalanced axial forces, the compressor shaft is equipped with a tilting pad, self-leveling, babbitted thrust bearing and a babbitted counterthrust bearing.

The hermetically sealed, 2-pole motor is an integral part of the compressor. The motor is cooled by subcooled liquid refrigerant, sprayed on all internal motor components. The motor stator can be serviced with only minor disassembly and without breaking major refrigerant piping.

Motors under 600 volts are built for connection to across-the-line full voltage, star-delta or reduced voltage starters. Motors above 600 volts are suitable for use with across-the-line or reduced voltage starters.

Cooler

The construction and materials of this welded steel vessel are in accordance with the ASME Code for Unfired Pressure Vessels. The water boxes are of high-grade fabricated steel, with weld-end stubouts for fluid connections and with tapped connections for both vent and drain.

The cooler tubes are 3/4-in. OD seamless finned copper. Tubes are not finned in the area adjacent to and in contact with the tube sheets and the tube support sheets. The tubes are rolled and expanded into grooved holes in the cooler tube sheets. They can be removed without affecting the strength and durability of the tube sheet and without causing leakage at adjacent tubes.

The tube sheets are of carbon steel and are welded to the cooler shell. The tube support sheets are spaced at intervals of 2-1/2 ft or less (depending on cooler size) to minimize tube vibration.

A refrigerant distribution system ensures uniform delivery of liquid refrigerant to all parts of the cooler tube bundle. In addition, a flow equalizing system provides balanced suction pressure throughout the cooler. This equalizing system also serves to prevent liquid carryover into the compressor.

The cooler is equipped with a refrigerant transfer connec-

tion. Gage connections and a refrigerant thermowell are also provided. Cooler relief valves are sized in accordance with the ANSI B9.1 Safety Code and are suitable for the attachment of vent piping.

Condenser

Like the 19FA cooler, the condenser is a welded steel vessel constructed in accordance with the ASME Code for Unfired Pressure Vessels wherever applicable. The nozzle-in-head water boxes are fabricated from certified materials and are machine welded to the condenser tube sheets. Vent and drain connections are provided on each box. Water nozzles are normally weld-end stubouts.

The 3/4-in. OD seamless copper tubes are finned except in the area of the tube sheet and tube support sheets. Each tube is rolled into a double-grooved hole in the condenser tube sheet for maximum strength and seal.

Four 1/2-in. thick steel tube support sheets, spaced at approximately 2 1/2-ft intervals, maintain proper tube clearance and minimize tube vibration. Several smaller sheets support the thermal economizer tubes and also act as baffles to bring the condensed refrigerant into full contact with the economizer tubes.

A curved inlet baffle in the path of the compressor discharge gas prevents direct impingement of high velocity gas on the condenser tubes and also distributes the refrigerant flow uniformly over the length of the vessel.

Economizer

The flash economizer is a single-stage economizer with a high-side float chamber, flash gas chamber and low-side float chamber. The flow control valve in the high-side chamber maintains condenser liquid at a level that completely immerses the thermal economizer section in liquid refrigerant. The low-side flow control valve maintains cooler liquid at a level sufficient to keep cooler tubes adequately wetted thru the full range of machine capacity. In the flash gas chamber, a portion of the liquid refrigerant flashes to vapor and is directed to the compressor inter-stage impeller. An economizer damper valve in the vapor line to the compressor ensures liquid refrigerant flow to the cooler under low-lift conditions. In addition, the damper valve blocks the flow of economizer gas to the compressor during start-up and thus minimizes motor load.

Storage tank (receiver)

The receiver is sized so that the entire refrigerant charge occupies not more than 90% of the tank volume at 90 F, in accordance with ANSI B9.1. The receiver is equipped with a means for determining refrigerant liquid level and is provided with relief valves and all necessary connections for refrigerant transfer.

Control system

Capacity control is fully automatic. Either solid state or full pneumatic control may be specified. Both types provide stable operation from design load thru 10% load under normal operating conditions. The throttling range for solid state capacity control can be limited to 1.5 F, the range for pneumatic control can be limited to 3 F.

All safety and control devices are suitable for 115-volt, single-phase, 60-Hz, a.c. service.

Machine safety devices are so arranged that the tripping of any one device will shut down the machine and require hand reset before machine restart.

Build your system around matched Carrier components

DEPENDABLE REFRIGERATION

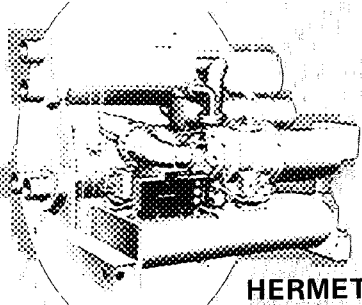

HERMETIC CENTRIFUGAL

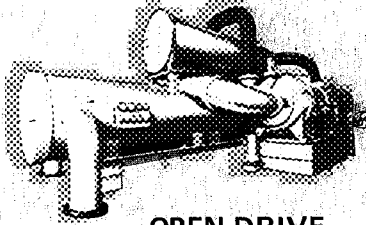

OPEN-DRIVE CENTRIFUGAL

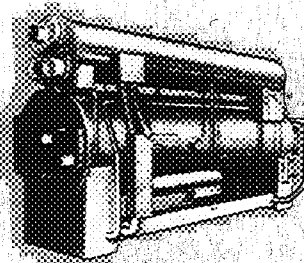

ABSORPTION

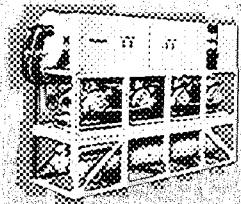

RECIPROCATING

RUGGED AIR HANDLING

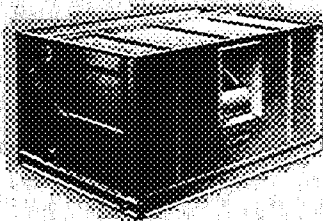

CENTRAL STATION

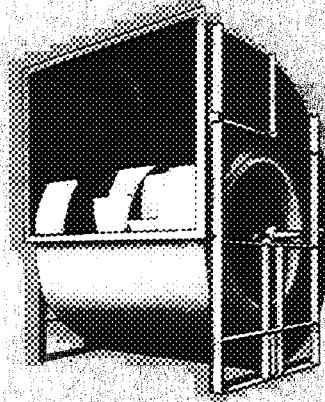

FANS

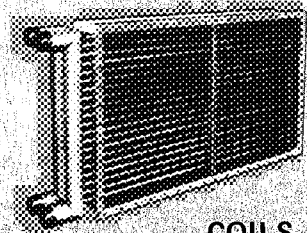

COILS



PACKAGED FAN COILS

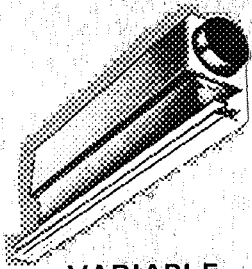

VARIABLE VOLUME

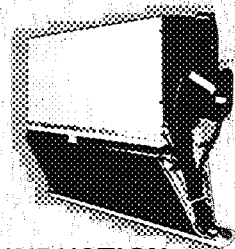

INDUCTION

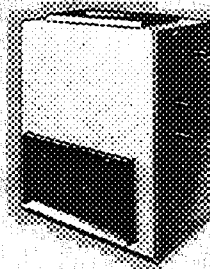

SMALL FAN COILS

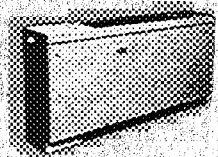

VERSATILE AIR TERMINALS

PLUS-many other specialized product lines...both packaged units and system components. Call your Carrier representative for information.

<p>Number One Air Conditioning Maker</p>	
<p><small>Division of Carrier Corporation Carrier Parkway • Syracuse N.Y. 13201</small></p>	

Manufacturer reserves the right to discontinue, or change at any time, specifications or designs without notice and without incurring obligations.