

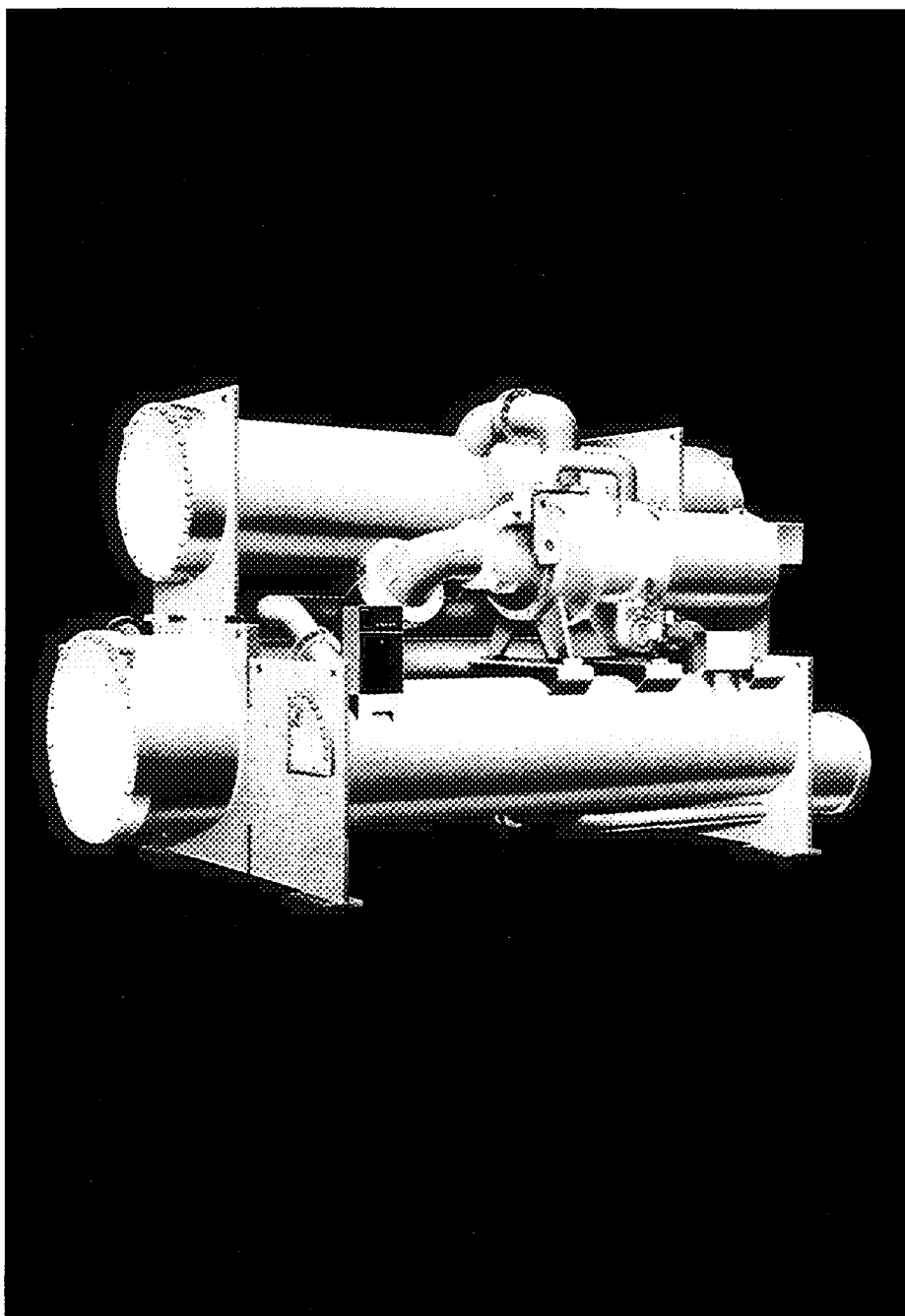

Product Data

19EX Hermetic Centrifugal Liquid Chiller 50/60 Hz

800 to 1300 Nominal Tons (2810 to 4570 kW)



Carrier's 19EX Hermetic Centrifugal Liquid Chillers operate with environmentally safe HFC-134a. These chillers combine industrial quality with superior efficiency in a packaged design for minimized system costs. The Carrier 19EX features:

- Single-Piece Modular Construction
- Hermetic 2-Stage Compressor Design with Interstage Economizer
- Positive Pressure Design Using Environmentally Safe HFC-134a Refrigerant

Features/Benefits

The 19EX hermetic centrifugal liquid chiller features:

Single-piece factory package — The 19EX is completely assembled in the factory and shipped as one piece to the jobsite, allowing each unit to be tested before customer delivery. This ensures that every aspect of the unit meets stringent quality standards specified by Carrier. One piece shipment also eliminates costly and time consuming field assembly

Modular construction — The cooler, compressor, condenser, and economizer/storage vessel assemblies are completely bolted together, making the 19EX ideally suited for replacement projects where ease of disassembly and re-assembly at the jobsite are essential.

Application flexibility — By providing a wide assortment of compressor and gear arrangements, the 19EX is an efficient, quality package ideally suited for domestic chilled water, export chilled water, brine chilling, and ice making duty applications.



The 2-Stage Hermetic compressor features:

Hermetic design — The motor is hermetically sealed from the machine room, with cooling being accomplished by spraying liquid refrigerant on the motor windings. This highly efficient motor cooling method enables the use of smaller motors than those of air-cooled designs of the same type. Thus, hermetic motors require less inrush current, and are smaller and lighter than comparable air-cooled motors. In addition, Carrier's hermetic design eliminates:

- **Compressor shaft seals** — These seals are common with open drive designs which require maintenance and increase the likelihood of refrigerant leaks.
- **Shaft alignment problems** — These problems occur with open drive designs during start-up and operation when equipment temperature variations cause thermal expansion.
- **High level noise** — Air cooled motors radiate noise to the machine room and adjacent areas.
- **Machine room cooling** — Because they are exposed to the environment, air-cooled motors require additional machine room cooling or ventilation.

Lubrication system — This forced lubrication system consists of an electrically-driven oil pump, filter, heater, and refrigerant-cooled oil cooler. It provides an adequate supply of oil to the transmission gears, and all bearing surfaces during start-up, operation, an coastdown. The electrically-driven oil pump is supplied by a separate power line ensuring an adequate oil supply in the event of compressor power interruptions. A microprocessor-controlled oil heater prevents excessive absorption of refrigerant into the oil during compressor shutdown. The refrigerant-cooled oil cooler eliminates field water piping, reducing installation expense.

Variable inlet guide vanes — These vanes are connected with aircraft-quality linkages and controlled by a precise electronic actuator. Chilled water temperature is maintained within $\pm .5$ F (3 C) of desired set point without surge, cavitation, or undue vibration. The vanes regulate inlet flow to provide high efficiency through a wide, stable operating range without hot gas bypass.

Double helical industrial type gears — Unlike single helical gears, double helical gears have greater tooth-contact area which can transmit higher horsepower loads more smoothly. In addition, this design absorbs axial thrust loads that are generated in the transmission of power, ensuring long dependable life for all components in the system.

Split-sleeve, steel back, babbitt-lined journal bearing — The 19EX uses two steel back, babbitt-lined

journal bearings on both sides of the thrust bearing to form a "fully supported" internal shaft. The steel backing provides structural strength for the bearing, while the babbitt material provides a superior bearing surface. The split-sleeve design facilitates bearing inspection without shaft removal. This makes for a very solid rotating assembly which reduces: heat, wear, vibration, and the possibility of shaft failure.

Table of contents

	Page
Features/Benefits	1-6
Model Number Nomenclature	2
Options and Accessories	6
Machine Components	7
Physical Data	8
Dimensions	9
Performance Data	10-13
Electrical Data	13,14
Application Data	15-20
Controls	21-25
Typical Control Wiring	26
Typical Field Wiring	27
Typical Piping and Wiring	28
Guide Specifications	29-34

Model number nomenclature

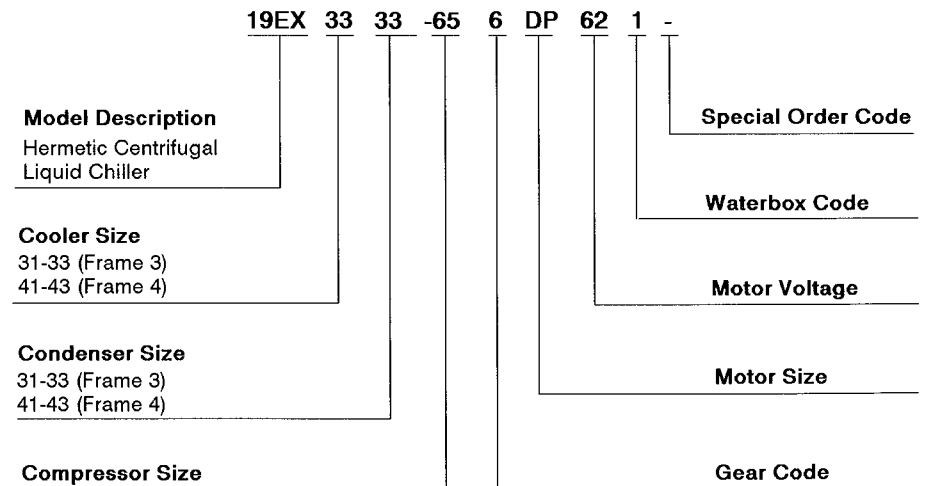

UNDERWRITERS' LABORATORIES



ARI (Air Conditioning and Refrigeration Institute) PERFORMANCE CERTIFIED

Features/Benefits (cont)

HEAT EXCHANGERS

- ASME stamp on both refrigerant and water-sides of heat exchangers for increased reliability
- Standard marine waterboxes eliminate disassembly of field piping, saving on service time during tube cleaning
- High-performance internally and externally enhanced tubes provide excellent heat transfer efficiencies
- Closely spaced intermediate support sheets prevent tube sagging and/or vibration
- Double-grooved tube sheets, with tubing rolled and expanded at both end sheets, provides leak-tight integrity
- Condenser impingement baffle eliminates tube vibration and increases heat exchanger efficiency
- Condenser thermal economizer increases refrigerant cycle efficiency

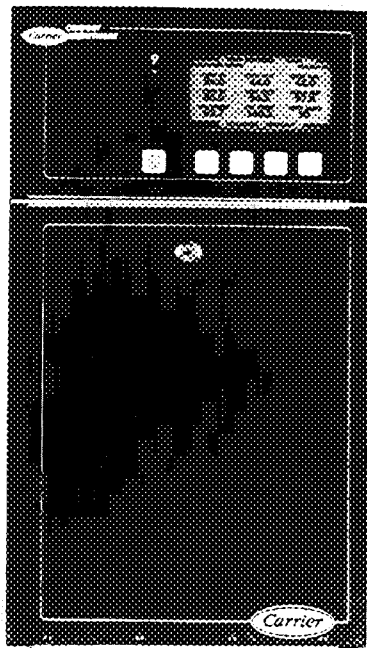

MICROPROCESSOR CONTROL SYSTEM

- Easy to read 16 line by 40 character LCD display
- "All in one glance" access to key chiller operating data simplifies machine-user interface
- Monitors over 100 functions and conditions for complete system control
- Displays over 125 operating and diagnostic conditions for the most detailed information available
- Carrier Comfort Network (CCN) compatibility provides a system solution to controls applications

19EX HERMETIC CENT

- Single-piece modular construction for new construction, or replacement
- Hermetic 2-stage compressor increases refrigeration efficiency
- Positive pressure design uses refrigerant

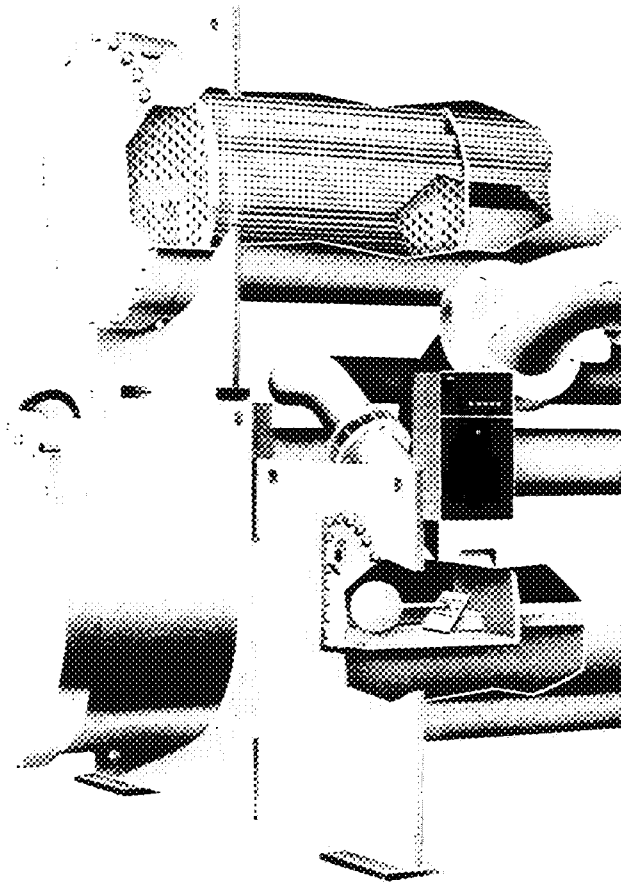

FLASH ECONOMIZER/PUMPOUT UNIT

- Increased refrigeration efficiency
- Reliable float valves provide liquid at any load condition
- Bolt-on covers allow for easy access
- Eliminates remote storage space
- Meets EPA standards
- Prevents refrigerant leakage
- Allows for evacuation without refrigerant
- Saves on service time

Features/Benefits (cont)

HEAT EXCHANGERS

- ASME stamp on both refrigerant and water-sides of heat exchangers for increased reliability
- Standard marine waterboxes eliminate disassembly of field piping, saving on service time during tube cleaning
- High-performance internally and externally enhanced tubes provide excellent heat transfer efficiencies
- Closely spaced intermediate support sheets prevent tube sagging and/or vibration
- Double-grooved tube sheets, with tubing rolled and expanded at both end sheets, provides leak-tight integrity
- Condenser impingement baffle eliminates tube vibration and increases heat exchanger efficiency
- Condenser thermal economizer increases refrigerant cycle efficiency

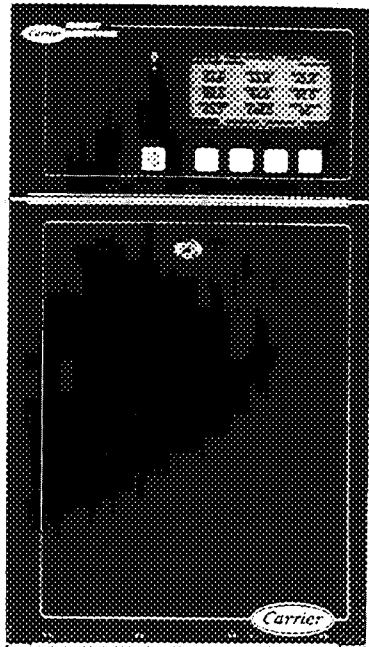

MICROPROCESSOR CONTROL SYSTEM

- Easy to read 16 line by 40 character LCD display
- "All in one glance" access to key chiller operating data simplifies machine-user interface
- Monitors over 100 functions and conditions for complete system control
- Displays over 125 operating and diagnostic conditions for the most detailed information available
- Carrier Comfort Network (CCN) compatibility provides a system solution to controls applications

19EX HERMETIC CENTRI

- Single-piece modular construction for new construction, or replacement
- Hermetic 2-stage compressor design increases refrigeration effect and efficiency
- Positive pressure design uses e refrigerant

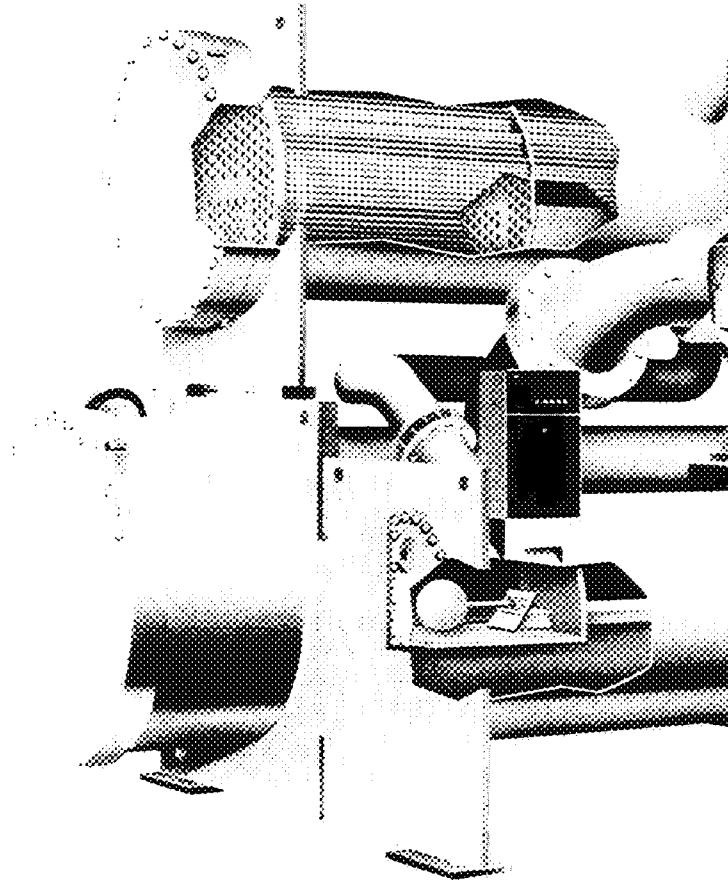

FLASH ECONOMIZER/STORAGE PUMPOUT UNIT

- Increased refrigeration effect and efficiency
- Reliable float valves provide protection at any load condition
- Bolt-on covers allow for easy inspection
- Eliminates remote storage system
- Meets EPA standards
- Prevents refrigerant leakage
- Allows for evacuation without oil
- Saves on service time

MODULAR LIQUID CHILLER

Carrier makes the 19EX ideally suited for replacement projects. The design features an interstage economizer for improved cycle efficiency and an environmentally safe HFC-134a refrigerant.

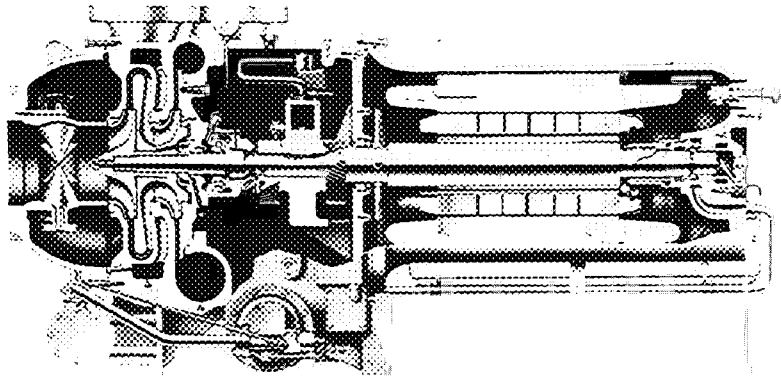

2-STAGE HERMETIC COMPRESSOR

- Hermetic design eliminates high noise level, shaft seal leakage, shaft alignment, and machine room cooling
- Hermetically sealed lubrication package provides adequate oil supply at start-up, operation, and coastdown
- Variable inlet guide vane capacity control provides stable operation without hotgas bypass
- Double helical gears transmit higher shaft load, and eliminate gear thrust load
- Split-sleeve, steel back, babbitt-lined journal bearings facilitates bearing inspection without shaft removal
- Tilting pad, self-leveling, babbitted Kingsbury-type thrust bearing absorbs axial thrust, increasing compressor life
- Large inspection opening facilitates bearing and gear inspection without compressor disassembly
- Refrigerant-cooled oil cooler eliminates field water piping and reduces installation expense
- Compressor is run-tested, ensuring proper and reliable operation

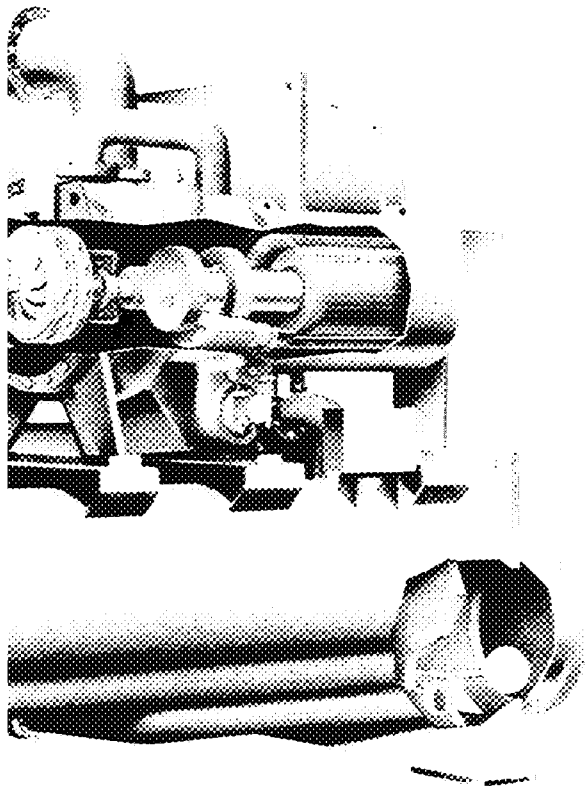

SINGLE-PIECE MODULAR CONSTRUCTION

- Single-piece factory package eliminates field assembly on new construction projects, reducing installation expense
- Modular construction allows for field disassembly and re-assembly on replacement projects, also reducing installation expense

STORAGE VESSEL AND

Carrier provides precise refrigerant flow control and accurate refrigerant flow control.

Inspection and maintenance.

Operation of main compressor.

Features/Benefits (cont)



Tilting pad, self-leveling, babbitt-lined, Kingsbury-type thrust bearing

— The Kingsbury-type thrust bearing employs an expanded equalized surface that faces a rotating disc on the shaft. This surface is comprised of eight pads made from babbitt. Each pad is supported by plates which give the pads a self-aligning nature, allowing for field adjustments. During operation, the pads take on a wedge-shape formation. This formation ensures that the load-carrying surfaces of the bearing are separated by a relatively thick film of lubricant, preventing metal-to-metal contact. In case of accidental reverse shaft rotation, the pads on the thrust bearing can realign themselves, and form a wedge-shape in the opposite direction, which will reduce wear and increase bearing life

Large inspection opening — Each compressor is equipped with an access cover to facilitate bearing and gear inspection without compressor disassembly. This makes the 19EX ideal for yearly inspections and preventive maintenance programs.

Compressor run tested — Every compressor assembly is overspeed run-tested in accordance with stringent Carrier engineering requirements. These tests, performed prior to final machine assembly, ensure proper and reliable operation.

The heat exchangers feature:

Pressure tested vessels — Each heat exchanger (water-side) is hydrostatically tested at 150% of design pressure. The entire machine assembly is pneumatically burst-tested at 125% of design pressure and then subjected to a standing vacuum test. This increases unit reliability and ensures safe machine operation.

ASME certified construction — ASME "U" stamp and nameplate on both refrigerant and water-sides of the chiller for safety, reliability and long life.

Marine waterboxes — The marine waterboxes, standard on both cooler and condenser, facilitate tube cleaning and eliminate the need to disassemble piping.

High-performance tubing — Heat exchanger tubes can be internally and externally enhanced for high efficiency. A wide range of alternate tube types and materials is available.

Double-grooved tube sheet holes — Tubing is rolled and expanded into double grooved tube sheets to eliminate the possibility of leaks between the water and refrigerant system.

Closely-spaced intermediate support sheets — Tubes in the cooler and condenser are supported by closely-spaced intermediate support sheets which prevent tubes from sagging and vibrating.

Tube expansion at intermediate support sheets — Because of the volatile environment in the cooler heat exchanger, tubes are expanded into each intermediate support sheet, preventing unwanted tube movement and vibration.

Condenser impingement baffle — This feature prevents direct impingement of high velocity compressor discharge gas onto the condenser tubes. The baffle eliminates the related vibration and wear of the tubes, and distributes the refrigerant flow evenly over the length of the vessel for improved efficiency.

Thermal economizer — The thermal economizer (subcooler), located in the bottom of the condenser, brings warm condensed refrigerant into contact with the inlet (coldest) water tubes. This subcools the liquid to a temperature less than its condensing temperature. Therefore, the overall refrigeration cycle efficiency is increased, resulting in lower power consumption.

The flash economizer/storage vessel features:

Integrated economizer/storage vessel with pumpout unit — This system is self-contained, easy to operate, and more cost effective than remote storage options. As a self-contained unit, the 19EX can be applied to applications that incorporate more than one type of refrigerant, without the cost penalty of requiring additional remote storage systems. Additionally, the optional pump-down compressor meets EPA's vacuum level requirements, which minimizes refrigerant emissions during service.

Interstage flash economizer — The liquid refrigerant leaving the condenser passes through two pressure reducing devices in the economizer/storage vessel before reaching the cooler. After going through the first device, some of the liquid flashes due to the sudden drop in pressure and is drawn off to the inlet of the compressor second stage, reducing the first stage weight flow and horsepower. As a result, the economizer increases refrigerant effect and cycle efficiency.

Ball-type float valves — These valves provide precise refrigerant metering at any load. As a result, optimal refrigerant levels can be maintained in the condenser and cooler to achieve the greatest efficiency, without gas bypass or flooding.

Bolt-on covers — These covers allow access to the float valves to facilitate inspection.

Storage tank — This tank is sized so that the entire refrigerant charge occupies no more than 90% of the tank volume at 90 F (32 C). This feature speeds up service work, minimizes downtime, eliminates the additional space required

for a separate tank, and the need for costly field-erected transfer piping.

Isolating valves — These valves isolate the integrated economizer/storage vessel from the condenser, cooler, and compressor during pump-out and servicing.

Microprocessor controls feature:

Direct digital Product Integrated Control (PIC) — The PIC provides unmatched flexibility and functionality. Each unit integrates directly with the Carrier Comfort Network (CCN) providing a system solution to controls applications.

Local Interface Device (LID) — This device, configured to display in either English or metric, provides unparalleled ease of human interface. A 16 line by 40 character LCD (liquid crystal display) intuitive display features four menu-specific soft keys. Default display offers "all in one glance" access to key chiller operating data, simplifying machine-user interface.

Optional modules — These modules offer control expandability by allowing chilled water reset and demand limit set points to be controlled from remote sources. Optional temperature sensors can also be connected and monitored by these modules.

Modular pull-out/plug-in design — Plug design reduces wiring requirements for easy installation.

Low voltage design — The class 2 control panel design provides the ultimate assurance of personal safety and control integrity.

Over 100 PIC monitoring functions and conditions — PIC displays over 125 operating, state, and diagnostic messages for improved user interface.

Battery backup — Battery backup provides protection during power failures and eliminates time consuming control reconfiguration.

Extensive service menu — The service menu can be password-protected to prevent unauthorized access. Built-in diagnostic capabilities aid troubleshooting and recommend proper corrective action for pre-set alarms resulting in greater uptime. The control test allows the user to confirm operation of inputs and outputs for increased confidence.

Automatic capacity override — This function unloads the compressor whenever key safety limits are approached, increasing unit life.

Encapsulated circuit board — Designed and built in-house, each board must meet Carrier's stringent quality standards resulting in superior reliability compared to open board designs.

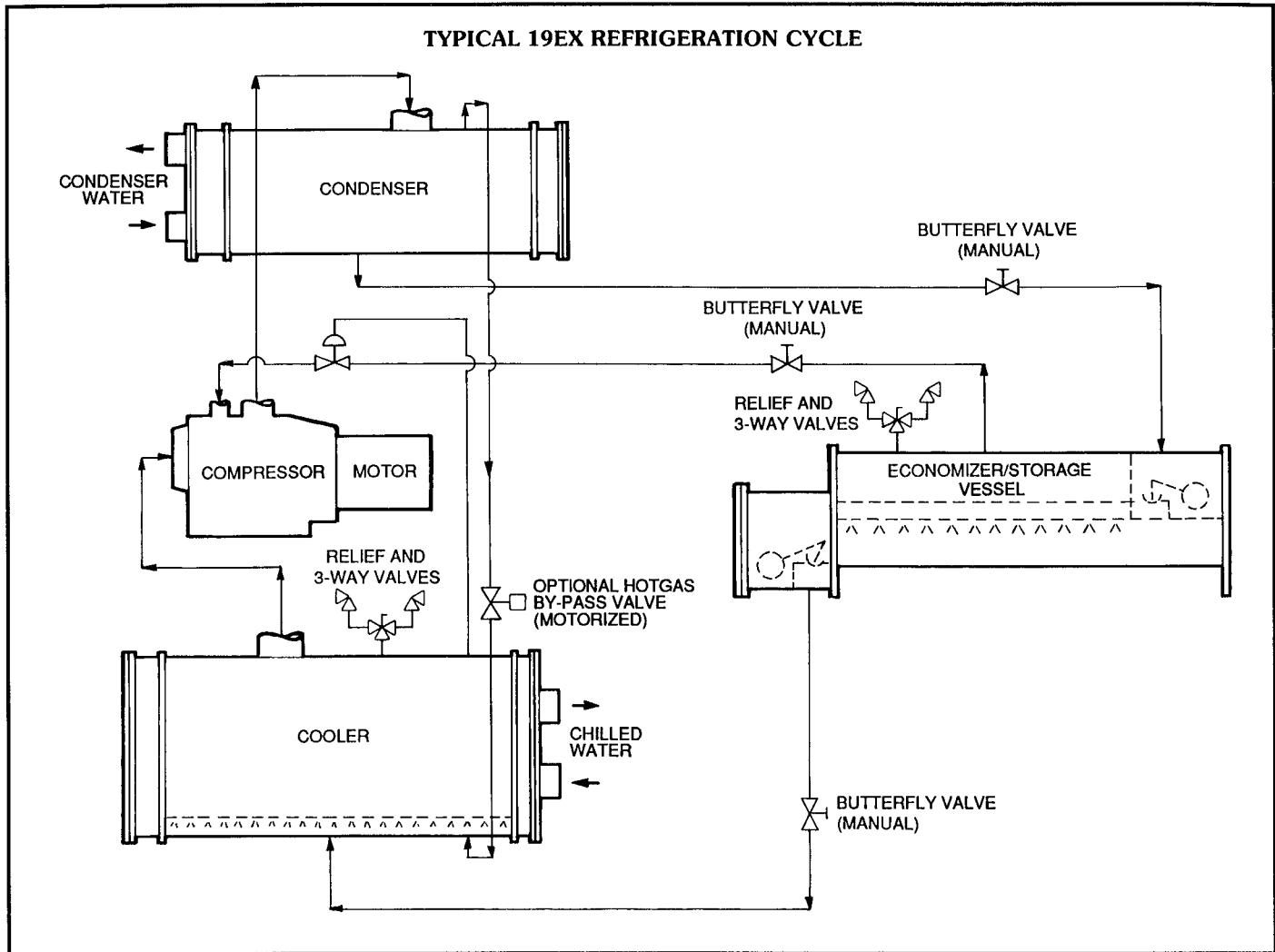

19EX refrigeration cycle

The machine compressor continuously draws large quantities of refrigerant vapor from the cooler, at a rate determined by the amount of guide vane opening. This compressor suction reduces the pressure within the cooler and causes the remaining refrigerant to boil vigorously at low temperature typically 35 to 40 F (2 to 4 C).

The energy required for boiling is obtained as heat from the water (or brine) flowing through the cooler tubes. With heat removed, the chilled water (brine) can then be used for air conditioning or for process liquid cooling.

After removing heat from the water, the refrigerant vapor passes through the compressor first stage, is then compressed and moves into the compressor second stage. Here it is mixed with flash-economizer gas and is further compressed.

Compression raises the refrigerant temperature above that of the water flowing through the condenser tubes. When the warm (typically 130 to 160 F) refrigerant is discharged into the condenser, the relatively cool condensing water removes some of the heat and the vapor condenses to a liquid. In water chilling machines, further removal of heat occurs in the thermal economizer at the bottom of the condenser. Here the liquefied refrigerant is subcooled by contact with the coolest (entering water) condenser tubes.

The liquid refrigerant drains into the flash economizer/storage vessel where a valve system maintains pressure intermediate between the condenser and the cooler pressure. At this lower pressure, part of the liquid refrigerant flashes to a gas, thus cooling the

remaining liquid. The flash gas is returned directly to the compressor. Here it is mixed with gas already compressed by the first-stage impeller. Since the economizer gas has to pass through only half of the compression cycle to reach condenser pressure, a saving in power is achieved, hence the term "economizer."

The cooled liquid refrigerant in the economizer is metered through the low-side float chamber to the cooler. Since cooler pressure is lower than the economizer pressure, some of the liquid flashes and cools the remainder to cooler temperature. The cycle is now complete.

Three manual butterfly valves are provided to allow isolation of the refrigerant charge in the economizer/storage vessel during chiller service.

COMPRESSOR COMPONENTS

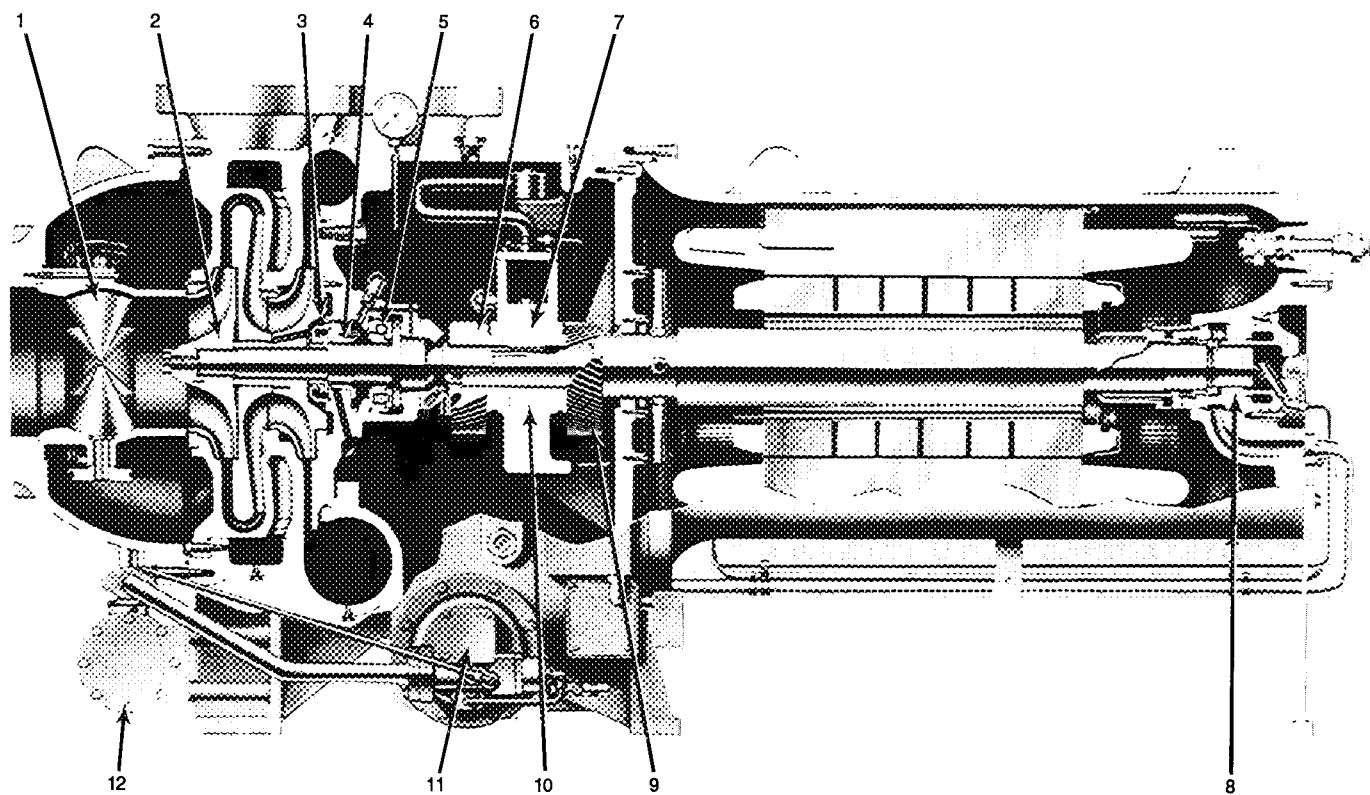

LEGEND

- | | | |
|------------------------------------|------------------------------------|----------------------------------|
| 1 — Variable Inlet Guide Vanes | 5 — Thrust Bearing Assembly | 9 — Low Speed Bull Gear |
| 2 — First-Stage Impeller | 6 — High-Speed Pinion | 10 — Motor Shaft Journal Bearing |
| 3 — Second-Stage Impeller | 7 — Impeller Shaft Journal Bearing | 11 — Oil Pump |
| 4 — Impeller Shaft Journal Bearing | 8 — Motor-End Journal Bearing | 12 — Oil Cooler |

Options and accessories

ITEM	OPTION*	ACCESSORY†
Full Insulation Including: Motor Shell Motor Cooling Lines Cooler Shell, Cooler Waterboxes and Covers Compressor Suction Elbow and Interconnecting Piping and Tubing	X	
Automatic Hot Gas Bypass	X	
Controls Option Module, Factory Mounted	X	
.028-in. Wall Copper Tubes, Internally Enhanced, Condenser	X	
.035-in. Wall Copper Tubes, Internally Enhanced, Cooler or Condenser	X	
.028 or .035-in. Wall Copper Tubes, Smooth Bore, Cooler or Condenser	X	
.028 or .035-in. Wall 90/10 CuNi Tubes, Internally Enhanced, Cooler or Condenser	X	
.028 or .035-in. Wall 90/10 CuNi Tubes, Smooth Bore, Cooler or Condenser	X	
.028-in. Wall Tubes, Condenser, Titanium, Smooth Bore	X	
Water Side Construction 1 or 3 Pass, Cooler and Condenser	X	
Waterbox Covers, 150 psig (1034 kPa)	X	
Water Nozzles, Flanged, Cooler and Condenser	X	
Factory Performance Test	X	
Export Crating	X	
Export Bagging	X	
Pumpout Unit: Factory Mounted, Piped and Wired	X	
Soleplate Package		X
Spring Isolators		X
Spare Sensors with Leads		X
Control Options Module Upgrade Kit		X

*Factory installed.

†Field installed.

Machine components

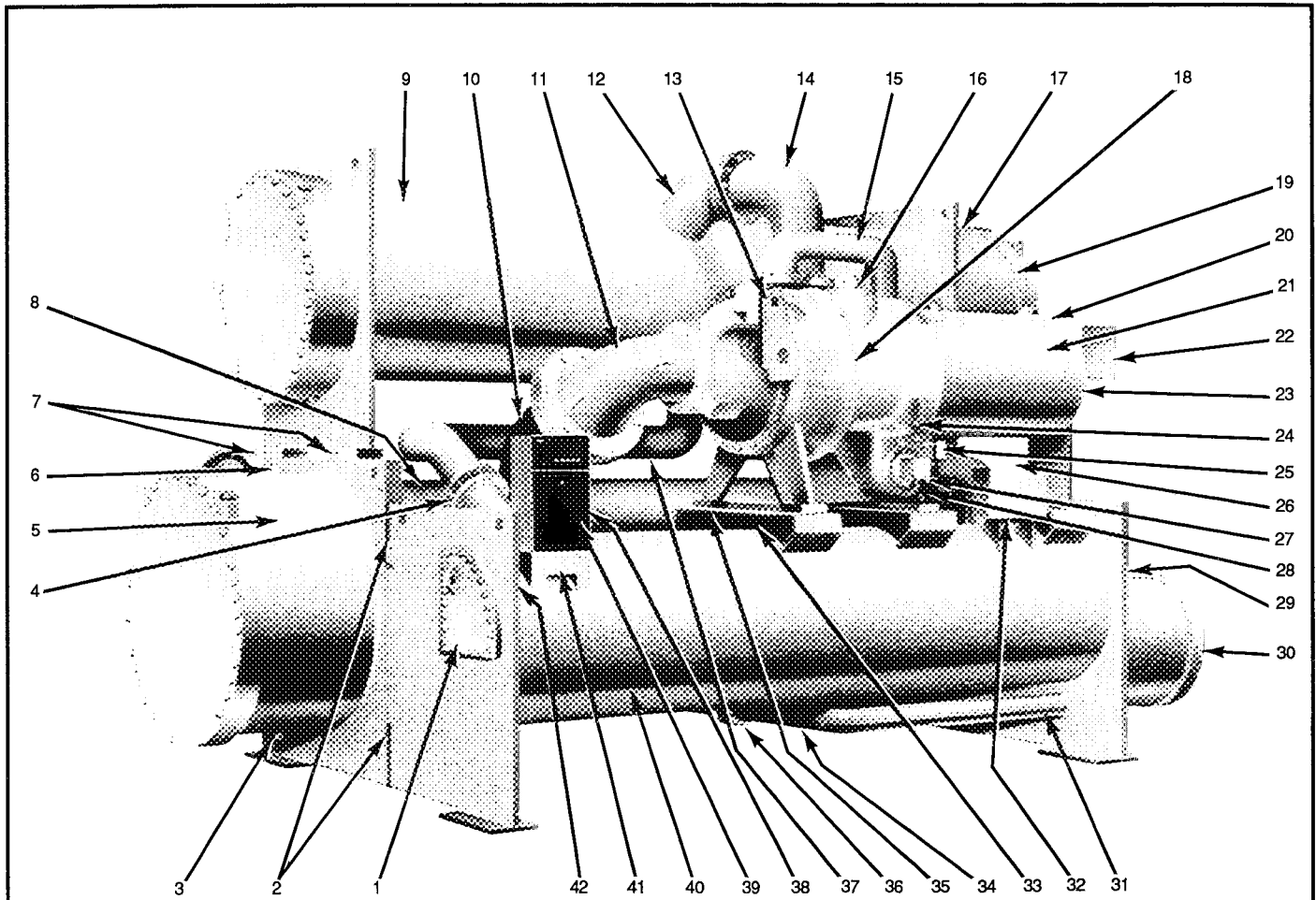

LEGEND

- | | | | |
|----|---|----|--|
| 1 | — High-Side Float Box Cover | 23 | — Motor Sight Glass (Not Shown) |
| 2 | — Take-Apart Connections | 24 | — Oil Level Sight Glasses (2) |
| 3 | — Cooler Waterbox Drain,
¾ in. FPT Connection | 25 | — Oil Heater |
| 4 | — Isolation Valves | 26 | — Cooler Relief Valves (Not Shown) |
| 5 | — Cooler Marine Waterboxes | 27 | — Oil Pump |
| 6 | — Cooler Waterbox Vent | 28 | — Oil Drain and Charging Valve |
| 7 | — Take-Apart Connections | 29 | — Pumpdown Unit (Not Shown) |
| 8 | — Cooler | 30 | — Low-side Float Box Cover |
| 9 | — Condenser | 31 | — Refrigerant Liquid Line to Cooler |
| 10 | — Cooler Suction Pipe | 32 | — Auxiliary Power Panel (Field Wiring Terminals) |
| 11 | — Compressor Suction Elbow | 33 | — Refrigerant Filter (Not Shown) |
| 12 | — Condenser Discharge Pipe | 34 | — Refrigerant Charging Valve
Service Valve 10 (Not Shown) |
| 13 | — Guide Vane Actuator | 35 | — Oil Cooler/Filter (Not Shown) |
| 14 | — Compressor Discharge Elbow | 36 | — Isolation Valve |
| 15 | — Economizer Gas Line to Compressor | 37 | — Refrigerant Liquid Line
to Economizer/Storage Vessel |
| 16 | — Gear Inspection Cover | 38 | — Economizer/Storage Vessel
Relief Valve (Not Shown) |
| 17 | — Condenser Waterbox Vent | 39 | — Local Interface Display Control Panel |
| 18 | — 2-Stage Hermetic Compressor | 40 | — Economizer/Storage Vessel |
| 19 | — Condenser Marine Waterboxes | 41 | — Machine Identification Plate (Not Shown) |
| 20 | — Condenser Waterbox Drain,
¾ in. FPT Connection (Not Shown) | 42 | — Rigging Guide (Not Shown) |
| 21 | — Hermetic Compressor Motor | | |
| 22 | — Compressor Motor Terminal Box | | |

Physical data



RIGGING AND OPERATING WEIGHTS* ENGLISH (lb)

HEAT EXCHANGER COMBINATIONS	3131	3232	3333	4141	4242	4343
Cooler	18,012	18,436	18,861	24,542	24,966	25,390
Condenser	12,025	12,381	12,736	15,772	16,121	16,471
Economizer/Storage Vessel	5,797	5,797	5,797	5,797	5,797	5,797
Controls	51	51	51	51	51	51
Compressor/Motor/Suction Elbow	8,107	8,107	8,107	9,500	9,500	9,500
Pumpout	210	210	210	210	210	210
Factory Piping	1,476	1,476	1,476	1,915	1,915	1,915
Cooler Water	3,370	3,496	3,622	4,645	4,771	4,897
Condenser Water	2,790	2,926	3,062	3,704	3,841	3,977
Cooler Refrigerant	1,935	2,035	2,140	2,255	2,342	2,449
Condenser Refrigerant	955	955	950	1,085	1,098	1,091
Economizer Refrigerant	610	610	610	610	610	610
Total Refrigerant Charge (134a)	3,500	3,600	3,700	3,950	4,050	4,150
Total Rigging Weight†	45,678	46,458	47,238	57,787	58,560	59,334
Total Operating Weight**	55,338	56,480	57,622	70,086	71,222	72,358

SI (kg)

HEAT EXCHANGER COMBINATIONS	3131	3232	3333	4141	4242	4343
Cooler	8 170	8 363	8 555	11 132	11 325	11 517
Condenser	5 455	5 616	5 777	7 154	7 312	7 471
Economizer/Storage Vessel	2 630	2 630	2 630	2 630	2 630	2 630
Controls	23	23	23	23	23	23
Compressor/Motor/Suction Elbow	3 677	3 677	3 677	4 309	4 309	4 309
Pumpout	95	95	95	95	95	95
Factory Piping	670	670	670	869	869	869
Cooler Water	1 529	1 586	1 643	2 107	2 164	2 221
Condenser Water	1 266	1 327	1 389	1 680	1 742	1 804
Cooler Refrigerant	878	923	971	1 023	1 062	1 111
Condenser Refrigerant	433	433	431	492	498	495
Economizer Refrigerant	277	277	277	277	277	277
Total Refrigerant Charge (134a)	1 588	1 633	1 678	1 792	1 837	1 882
Total Rigging Weight†	20 720	21 073	21 427	26 212	26 563	26 914
Total Operating Weight**	26 101	25 619	26 137	31 791	32 306	32 822

*Based on 2-pass marine waterboxes, 300 psig (2068 kPa) covers, maximum compressor, refrigerant 134a, and maximum motor and voltage.

†Total rigging weight does not include refrigerant.

**Total operating weight includes refrigerant and water

Dimensions

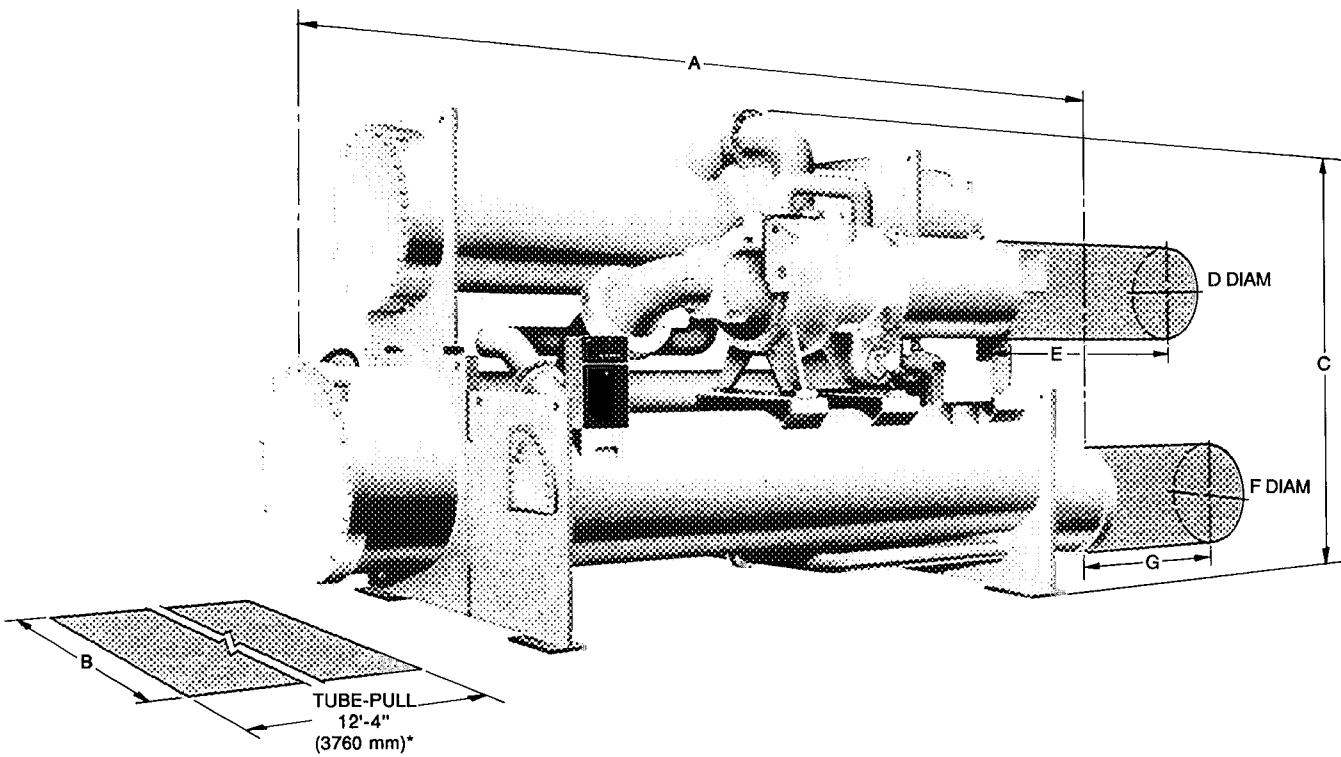

*Distance required for tube removal may be either end.
NOTE: Certified drawings available upon request

DIMENSIONS

HEAT EXCHANGER SIZE	FRAME SIZE	A (LENGTH)*		B (WIDTH)		C (HEIGHT)	
		ft-in.	mm	ft-in.	mm	ft-in.	mm
3133 3232 3333	3	18-3¼	5569	8-10	2692	10-11¼	3346
4141 4242 4343	4	18-8½	5702	9- 6½	2908	12- 7	3835

*Length includes marine waterbox on both ends.

SERVICE CLEARANCE

COMPONENT	D (DIAMETER)		E (LENGTH)		F (DIAMETER)		G (LENGTH)	
	ft-in.	mm	ft-in.	mm	ft-in.	mm	ft-in.	mm
MOTOR DK-DQ	1-11¼	591	3- 7½	1105	—	—	—	—
MOTOR EA-ED	2- 2¾	679	3-10¼	1175	—	—	—	—
LOW SIDE FLOAT	—	—	—	—	2-6½	775	1-0	305

NOZZLE SIZES

HEAT EXCHANGER SIZE	FRAME SIZE	NOZZLE SIZES (in.)*					
		Cooler Passes			Condenser Passes		
		1	2	3	1	2	3
3133 3232 3333	3	18	12	10	18	12	10
4141 4242 4343	4	20	14	12	20	14	12

*10 and 20-in nozzles are Schedule 20.
12-in. nozzles are .250W, .312W, or .375W.
14 and 18-in nozzles are .312W or .375W.
Victaulic grooves are standard for these nozzles.

Performance data



Computerized ratings

Because of the large number of available Carrier 19EX chiller component combinations and the wide variability in required operating conditions, it is impractical to provide tabular performance information. Tabulated performance ratings predict "typical" chiller performance. Actual chiller performance may vary significantly at actual operating conditions and as chiller components are optimized around these conditions.

Computerized performance ratings are available through your local Carrier sales representative. These ratings are custom matched to meet project-specific operating conditions and energy efficiency requirements.

ARI Certification Program

The computerized performance ratings of the Carrier 19EX chiller are certified by the Air Conditioning and Refrigeration Institute (ARI). The Certification Program requires that the manufacturer's ratings be regularly checked for accuracy through a program of chiller testing in strict compliance with ARI Standard 550. This independent verification provides assurance of chiller performance.

Part-load performance

Frequently, a chiller will operate at part-load for a large majority of its total operating hours. In some cases, a chiller with better part-load performance will offer an annualized operating cost advantage over one which performs less efficiently at lower loads.

Established by ARI, the Integrated Part-Load Value (IPLV) is a weighted average of kW/ton values over a wide range of chiller operation. IPLV provides a convenient method of comparing the part-load performance of different chillers at standardized typical conditions. The IPLV rating method has been incorporated into the ARI Certification Program. The 19EX chiller computerized ratings are certified in accordance with this program.

Variables such as local weather data, building load profiles, and local utility rate structures may significantly alter the impact of part-load performance on actual operating cost. Any operating cost analysis should include all factors relevant to a particular application.

TYPICAL COOLER PRESSURE DROP
19EX, 1 PASS COOLER, MARINE WATERBOX — STANDARD TUBING
FRESH WATER AT 50 F (10 C), WATER VELOCITIES FROM 3 TO 12 FT/SEC (0.9 TO 3.6 M/SEC)

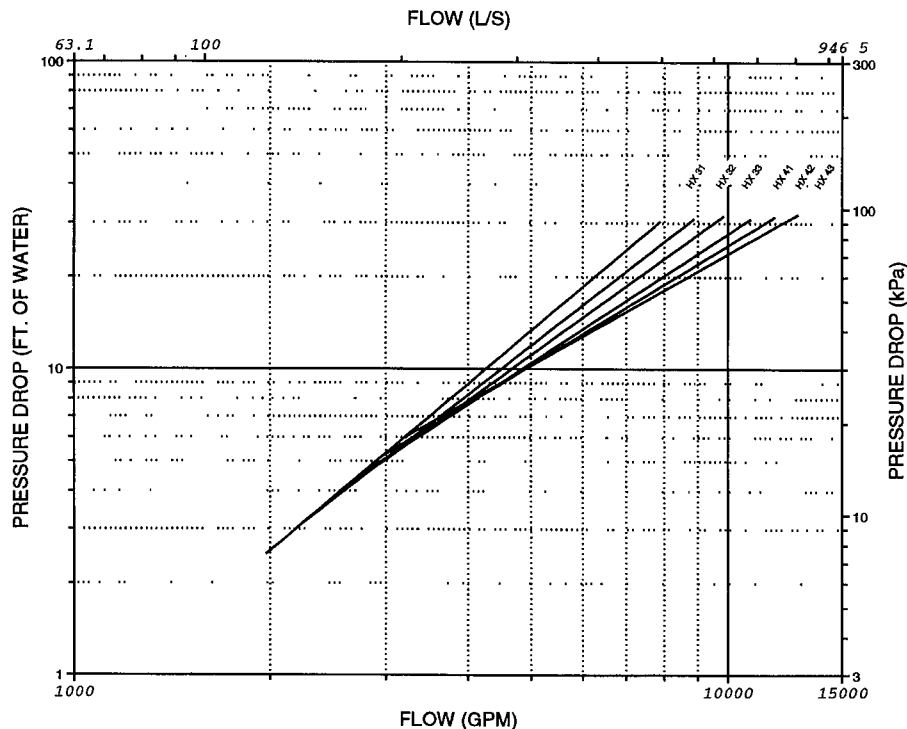

NOTES:

1. HX-- designations are cooler heat exchanger sizes.
2. To determine pressure drops more accurately and to compensate for actual water temperature, use the computerized selection service available through your local Carrier Sales office

Performance data (cont)

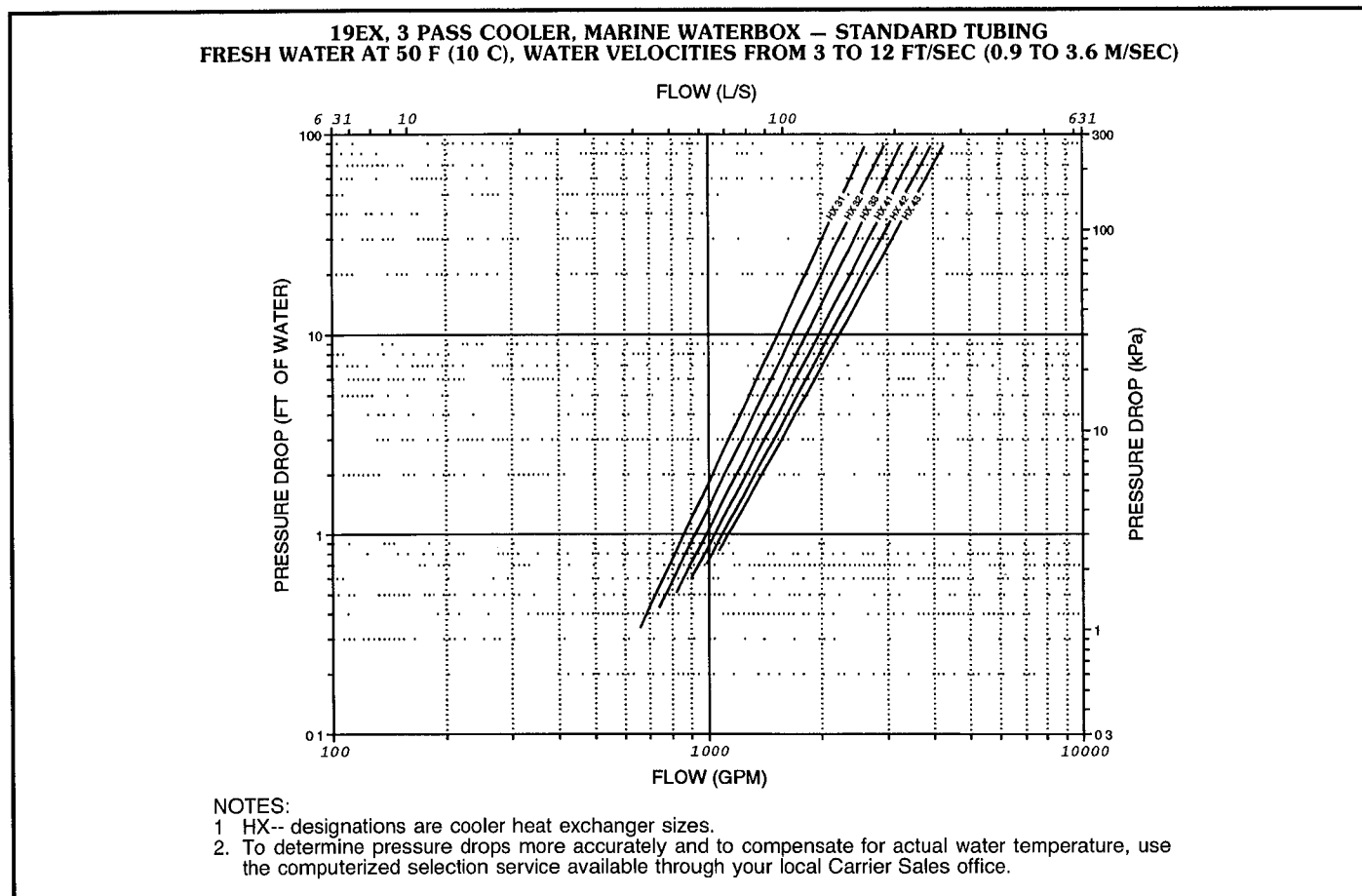
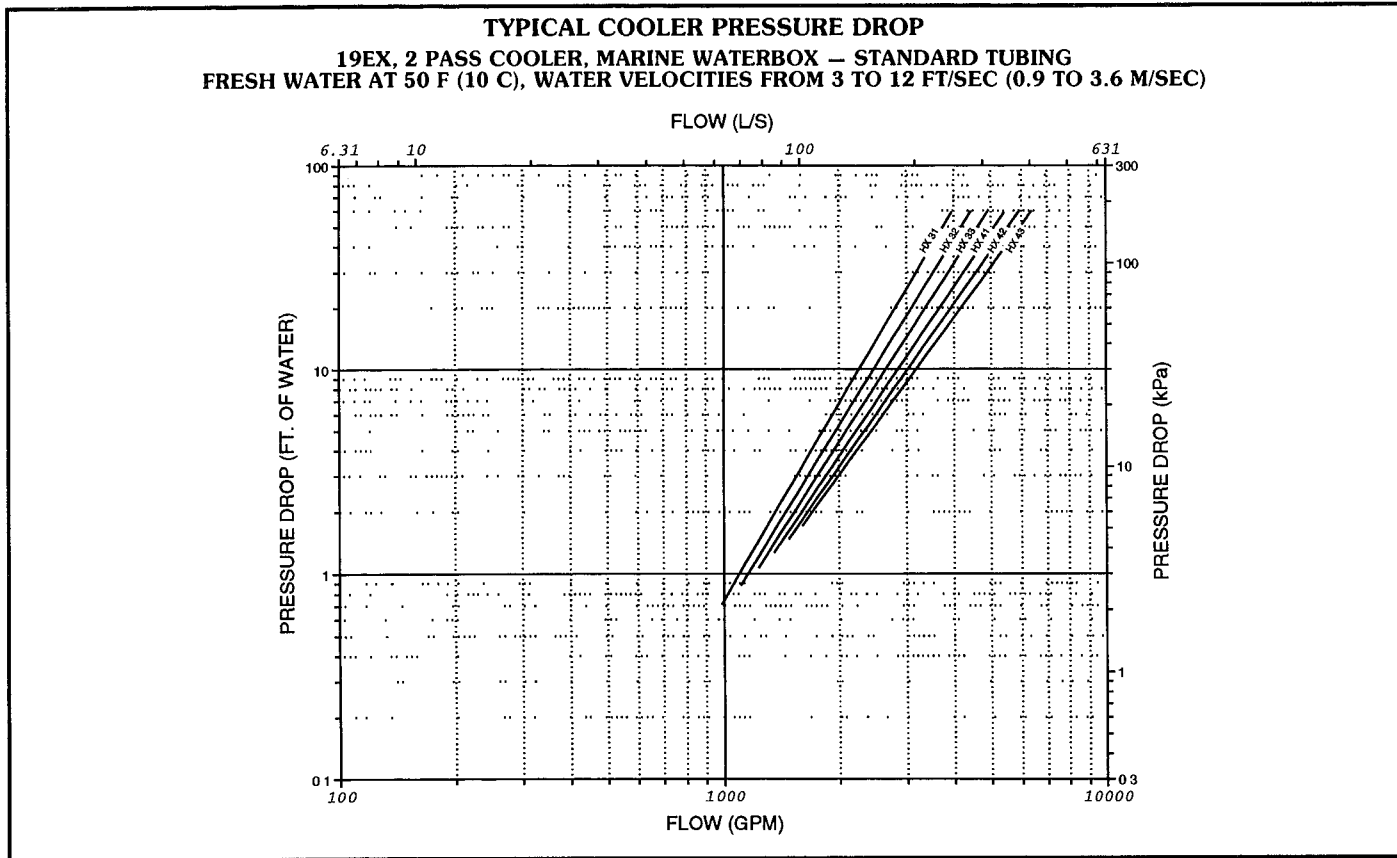



TYPICAL CONDENSER PRESSURE DROP
19EX, 1 PASS CONDENSER, MARINE WATERBOX – STANDARD TUBING
FRESH WATER AT 90 F (32 C), WATER VELOCITIES FROM 3 TO 12 FT/SEC (0.9 TO 3.6 M/SEC)

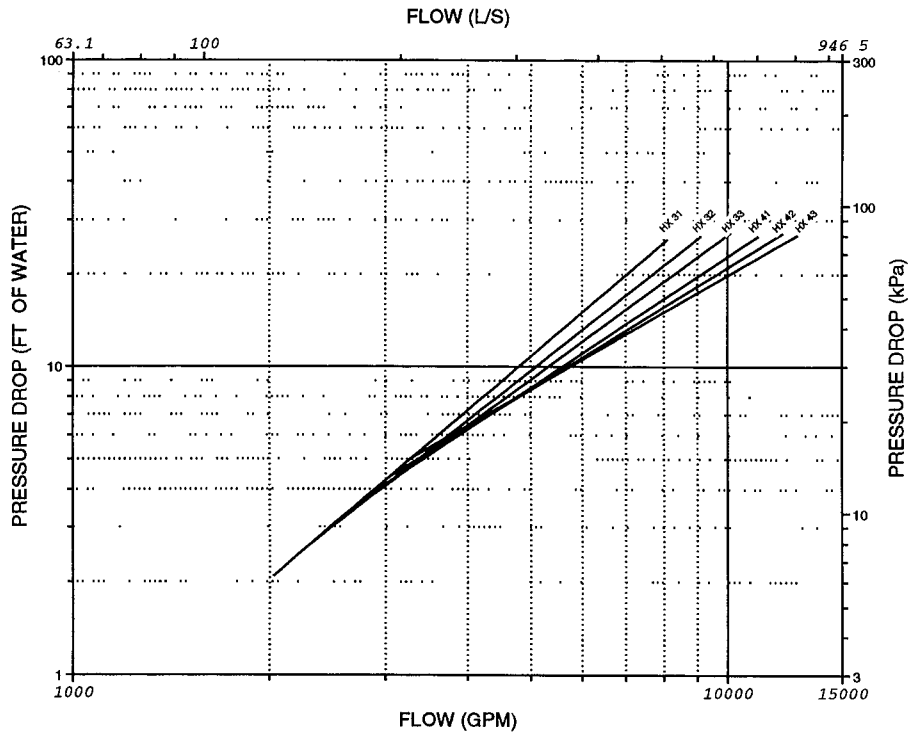

19EX, 2 PASS CONDENSER, MARINE WATERBOX – STANDARD TUBING
FRESH WATER AT 90 F (32 C), WATER VELOCITIES FROM 3 TO 12 FT/SEC (0.9 TO 3.6 M/SEC)

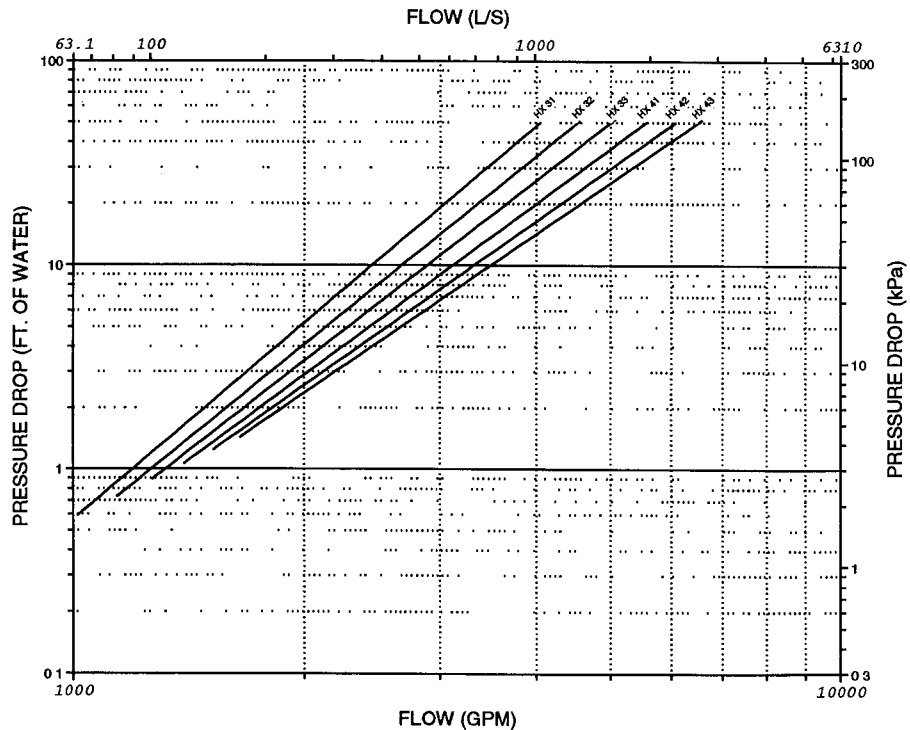

- NOTES:
1 HX-- designations are condenser heat exchanger sizes.
2 To determine pressure drops more accurately and to compensate for actual water temperature, use the computerized selection service available through your local Carrier Sales office

Performance data (cont)

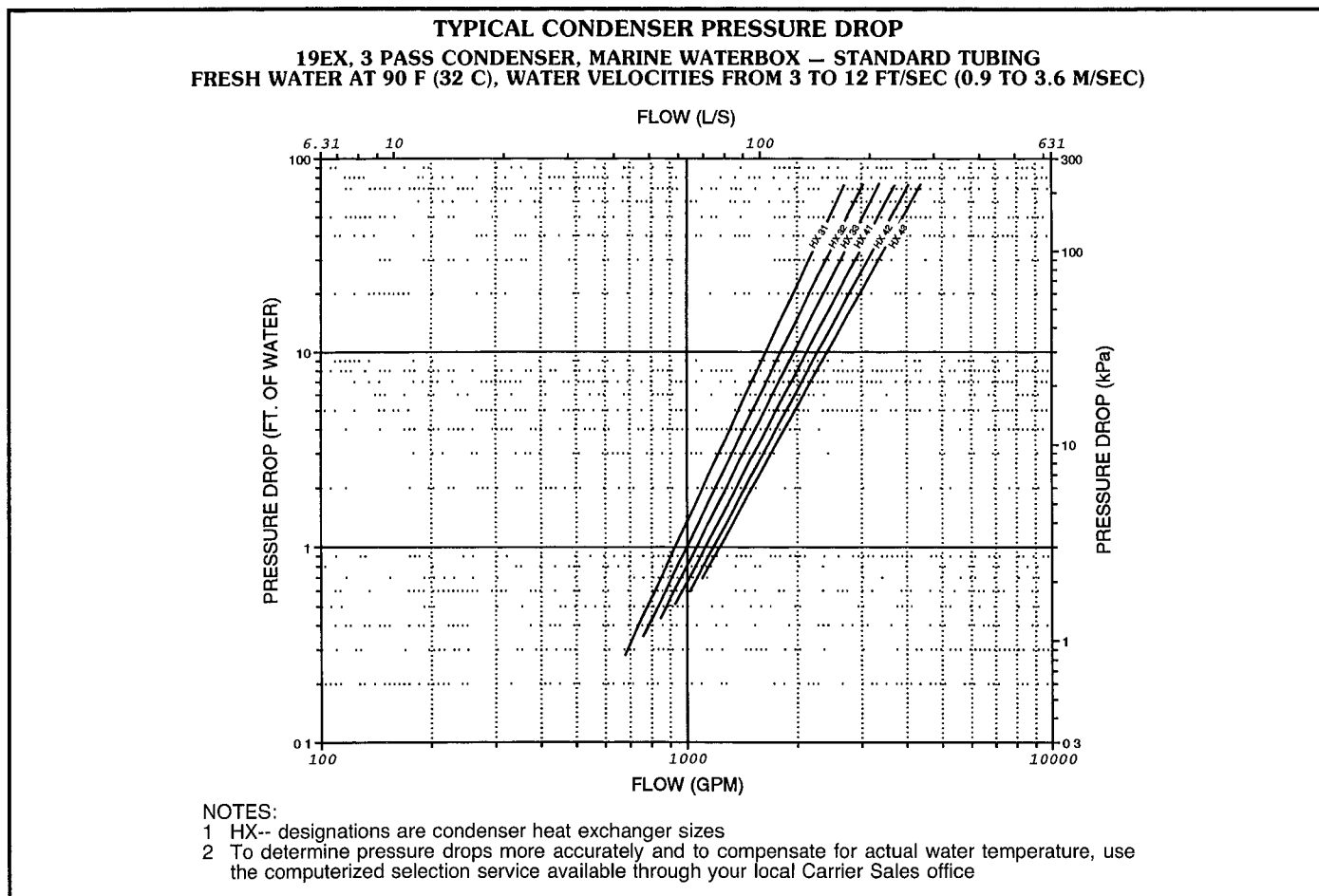

Electrical data

AUXILIARY RATINGS

POWER SOURCE	ITEM	AVERAGE kW	DESIGN CENTER VOLTAGE	SUPPLY V-PH-HZ	FLA	LRA
1	Control Module and Actuator	0.253	115	115-1-60 115-1-50	2.20	—
	Oil Sump Heater	1.0	115	115-1-60 115-1-50	8.70	—
2	Oil Pump	1.65	220	200/240-3-60	4.32	24.5
		1.60	430	380/480-3-60	2.00	12.2
		2.08	563	507/619-3-60	2.09	24.5
		1.93	230	220/240-3-50	4.83	28.0
		1.76	393	380/440-3-50	2.49	11.7
3 (Optional)	Pumpout Compressor	3.34	204	200/240-3-60	8.80	48.5
			230	220/240-3-60	7.60	43.0
			460	440/480-3-60	3.80	22.5
			220	210/230-3-50	6.40	35.8
			398	380/415-3-50	3.80	21.5

NOTES

- The oil pump is powered through a field wiring terminal into the power panel, see Machine Components section.
- Power to the controls and oil heater via the power panel must be on circuits that can provide continuous service when the compressor starter is disconnected.

Compressor motor controllers

Compressor motors, as well as controls and accessories, require the use of starting equipment systems specifically designed for 19 Series Chillers. See Application Data or starting equipment publications, or consult Carrier regarding design information for selection of controllers.

Capacitors and power factors

Power factor considerations may indicate the need to use capacitors. Properly sized capacitors improve power factors, especially at part-load. Contact local Carrier sales office for further information on power factors.

Electrical data (cont)



LOW-VOLTAGE MOTORS — 60 HZ

MOTOR SIZE	MAX kW	VOLTS*	380 V	460 V	575 V
DK	639	FLA per kW	1.69	1.39	1.12
		LRA Star	1847	1526	1221
		LRA Delta	5772	4769	3815
DL	685	FLA per kW	1.69	1.39	1.12
		LRA Star	1993	1647	1317
		LRA Delta	6228	5145	4116
DM	740	FLA per kW	1.68	1.39	1.11
		LRA Star	1901	1749	1185
		LRA Delta	6463	5920	4037
DN	801	FLA per kW	1.68	1.38	1.11
		LRA Star	2087	1665	1332
		LRA Delta	7090	5659	4528
DP	869	FLA per kW	1.68	1.39	1.11
		LRA Star	2057	1714	1344
		LRA Delta	7011	5846	4587
EA	968	FLA per kW	—	1.38	1.11
		LRA Star	—	2250	1800
		LRA Delta	—	7025	5620
EB	1080	FLA per kW	—	1.38	1.11
		LRA Star	—	2510	2010
		LRA Delta	—	7845	6275
EC	1188	FLA per kW	—	1.38	1.11
		LRA Star	—	2770	2218
		LRA Delta	—	8655	6930
ED	1310	FLA per kW	—	1.38	1.11
		LRA Star	—	3050	2440
		LRA Delta	—	9540	7630

MEDIUM AND HIGH-VOLTAGE MOTORS — 60 HZ

MOTOR SIZE	MAX kW	VOLTS*	2400 V	3300 V	4160 V	6900 V
DK	609	FLA per kW	.270	.197	.156	.094
		LRA Star	—	—	—	—
		LRA Delta	758	551	437	269
DL	659	FLA per kW	.270	.197	.156	.094
		LRA Star	—	—	—	—
		LRA Delta	829	604	479	291
DM	709	FLA per kW	.270	.197	.156	.094
		LRA Star	—	—	—	—
		LRA Delta	909	660	524	313
DN	770	FLA per kW	.270	.197	.156	.094
		LRA Star	—	—	—	—
		LRA Delta	972	707	561	336
DP	835	FLA per kW	.270	.197	.156	.094
		LRA Star	—	—	—	—
		LRA Delta	1054	766	608	370
DQ	875	FLA per kW	.270	.197	.156	.094
		LRA Star	—	—	—	—
		LRA Delta	1121	815	646	388
EA	968	FLA per kW	.265	.197	.153	.092
		LRA Star	—	—	—	—
		LRA Delta	1346	980	770	469
EB	1080	FLA per kW	.265	.197	.153	.092
		LRA Star	—	—	—	—
		LRA Delta	1502	1094	866	523
EC	1188	FLA per kW	.265	.197	.153	.092
		LRA Star	—	—	—	—
		LRA Delta	1660	1209	958	577
ED	1310	FLA per kW	.265	.197	.153	.092
		LRA Star	—	—	—	—
		LRA Delta	1828	1331	1053	636

LEGEND

FLA — Full Load Amps per kW Input
LRA — Locked Rotor Amps

*Listed motor voltages are design voltages. Motors are suitable for use with supply voltages as noted, and will operate satisfactorily at 10% below the minimum and at 10% above the maximum supply voltage

- 380 v — for use on 360- to 400-v systems
- 460 v — for use on 440- to 480-v systems
- 575 v — for use on 550- to 600-v systems
- 2400 v — for use on 2300- to 2500-v systems
- 3300 v — for use on 3150- to 3450-v systems
- 4160 v — for use on 4000- to 4300-v systems
- 6900 v — for use on 6600- to 7200-v systems

†3 Leads

Power Factor: Low voltage — .90
High voltage — .89

Listed motor voltages are design voltages. Motors are suitable for use with supply voltages as noted, and will operate satisfactorily at 10% below the minimum and at 10% above the maximum supply voltage

LOW-VOLTAGE MOTORS — 50 HZ

MOTOR SIZE	MAX kW	VOLTS*	346 V	400 V
DK	603	FLA per kW	1.85	1.60
		LRA Star	1655	1431
		LRA Delta	5173	4474
DL	649	FLA per kW	1.84	1.59
		LRA Star	1772	1759
		LRA Delta	6020	5944
DM	698	FLA per kW	1.84	1.59
		LRA Star	1904	1744
		LRA Delta	6469	5919
DN	756	FLA per kW	1.84	1.59
		LRA Star	2116	1887
		LRA Delta	7178	6401
DP	825	FLA per kW	—	1.60
		LRA Star	—	1940
		LRA Delta	—	6062
DQ	876	FLA per kW	—	1.60
		LRA Star	—	2124
		LRA Delta	—	6639
EA	968	FLA per kW	—	1.57
		LRA Star	—	2589
		LRA Delta	—	8093
EB	1080	FLA per kW	—	1.56
		LRA Star	—	2893
		LRA Delta	—	9041
EC	1188	FLA per kW	—	1.57
		LRA Star	—	3192
		LRA Delta	—	9976
ED	1310	FLA per kW	—	1.56
		LRA Star	—	3517
		LRA Delta	—	10,993

MEDIUM AND HIGH-VOLTAGE MOTORS — 50 HZ

MOTOR SIZE	MAX kW	VOLTS*	3000 V	3300 V	6300 V
DK	609	FLA per kW	216	197	103
		LRA Star	—	—	—
		LRA Delta	620	527	295
DL	660	FLA per kW	.216	.197	.103
		LRA Star	—	—	—
		LRA Delta	672	611	320
DM	710	FLA per kW	.216	.197	.103
		LRA Star	—	—	—
		LRA Delta	722	656	344
DN	770	FLA per kW	.216	.197	.103
		LRA Star	—	—	—
		LRA Delta	774	703	368
DP	835	FLA per kW	.216	.197	.103
		LRA Star	—	—	—
		LRA Delta	851	773	405
DQ	878	FLA per kW	.216	.197	.103
		LRA Star	—	—	—
		LRA Delta	903	821	430
EA	968	FLA per kW	.216	.197	.101
		LRA Star	—	—	—
		LRA Delta	1080	980	513
EB	1080	FLA per kW	.216	.197	.101
		LRA Star	—	—	—
		LRA Delta	1202	1094	573
EC	1188	FLA per kW	.216	.197	.101
		LRA Star	—	—	—
		LRA Delta	1329	1209	632
ED	1310	FLA per kW	.216	.197	.101
		LRA Star	—	—	—
		LRA Delta	1463	1331	696

- 346 v — for use on 320- to 360-v systems
- 400 v — for use on 380- to 415-v systems
- 3000 v — for use on 2900- to 3100-v systems
- 3300 v — for use on 3200- to 3400-v systems
- 6300 v — for use on 6000- to 6600-v systems

NOTE: To establish electrical data for your selected voltage, if other than listed voltage, use the following formulas

$$FLA = \text{listed FLA} \times \frac{\text{selected voltage}}{\text{listed voltage}}$$

$$OLTA = \text{listed OLTA} \times \frac{\text{listed voltage}}{\text{selected voltage}}$$

$$LRA = \text{listed LRA} \times \frac{\text{listed voltage}}{\text{selected voltage}}$$

EXAMPLE: Find the full load amperage for a motor listed at 1.12 amps per kW input and 550 volts

$$FLA = 1.12 \times \frac{575}{550} = 1.17$$

Application data



Range of application

The 19EX refrigeration machine is designed for standard water chilling applications using HFC-134a.

ASME stamping

All 19EX heat exchangers are constructed in accordance with ASME code requirements for Unfired Pressure Vessels (Section VIII) ASME nameplates with "U" stamps are affixed to the refrigerant side and water side of all vessels.

Design pressure

Design and test pressures for 19EX heat exchangers are listed below

DESIGN AND TEST PRESSURES

COMPONENT	DESIGN		HYDROSTATIC		AIR TEST	
	psi	kPa	psi	kPa	psi	kPa
SHELL SIDE (Refrigerant) Cooler	225	1551	—	—	281	1957
Condenser	225	1551	—	—	281	1937
TUBE SIDE (Water) Cooler	300	2061	450	3103	—	—
Condenser	300	2069	450	3103	—	—
Economizer/ Storage Vessel	225	1551	—	—	281	1937

HEAT EXCHANGER MATERIAL SPECIFICATIONS

COMPONENT	MATERIAL	SPECIFICATION
Shell Tube Sheet Waterbox Cover Waterbox Shell	HR Steel	ASME SA516 Gr70
Tubes	Finned Copper	ASME SB359
Discharge/Suction	Steel Pipe	ASME SA106 GrA
	and Pipe Fittings	ASME SA105

INSULATION REQUIREMENTS

SHEET FOAM INSULATION

COMPONENT	ft ²	m ²
Motor Shell	27	2.5
Economizer Low Side	48	4.5
Cooler and Waterboxes	273	25.4
Suction Line	25	2.3

FOAM TUBING INSULATION

TYPE	Ft	m
1½" Foam Tubing	9	2.7
1½" Foam Tubing	2	0.6
2" Foam Tubing	6	1.8
4" Foam Tubing	11	3.4

NOTES:

- Cooler value includes marine waterbox on one end (even-pass arrangement)
- Values are approximate.
- Factory insulation is optional.
- Includes entire cooler motor shell, cooler waterboxes and covers suction elbow, interconnecting pipes and tubing.

Insulation at jobsite

The Condensation versus Relative Humidity table indicates the degree of surface condensation that will occur for specific conditions of temperature and relative humidity. Carrier recommends that insulation be added to the cooler waterboxes (including the tube sheet) and suction elbow if the actual operating conditions would cause condensation.

Insulation of the cooler waterboxes should allow for service access and removal of covers.

The recommended insulation is ¾ in. (19 mm) thick closed-cell neoprene with a thermal conductivity K value of $0.28 \frac{\text{Btu} \cdot \text{in.}}{\text{hr} \cdot \text{ft} \cdot ^\circ\text{F}^2}$ ($0.0404 \frac{\text{W}}{\text{m}} ^\circ\text{C}$). Insulation should conform with UL (Underwriters' Laboratories) Standard 94 and have classification 94 HBF.

Factory insulation (optional) — Optional factory insulation is available for the evaporator shell and tube sheets, suction pipe, compressor motors, and refrigerant drain line(s). Insulation applied at the factory is ¾ in. (19.0 mm) thick and has a thermal conductivity K value of $0.28 \frac{\text{Btu} \cdot \text{in.}}{\text{hr} \cdot \text{ft} \cdot ^\circ\text{F}^2}$ ($0.0404 \frac{\text{W}}{\text{m}} ^\circ\text{C}$). Insulation conforms with UL Standard 94, Classification 94 HBF.

CONDENSATION VS RELATIVE HUMIDITY*

AMOUNT OF CONDENSATION	ROOM DRY-BULB TEMP			
	80 F (27 C)	90 F (32 C)	100 F (38 C)	
	% Relative Humidity			
None	80	76	70	
Slight	87	84	77	
Extensive	94	91	84	

*These approximate figures are based on 35 F (1.7 C) saturated suction temperature. A 2 F (1.1 C) change in saturated suction temperature changes the relative humidity values by 1% in the same direction.

Vent and drain connections

All vent and drain connections are found in the waterbox shell. Vent and drain connection size is ¾ in. NPT.

Provide high points of the machine piping system with vents and the low points with drains. If shutoff valves are provided in the main water pipes near the unit, a minimum amount of system water is lost when the heat exchangers are drained. This reduces the time required for drainage and saves on the cost of re-treating the system water.

It is recommended that pressure gages be provided at points of entering and leaving water to measure pressure drop through the heat exchanger. Gages may be installed as shown in the Pressure Gage Location table. Pressure gages installed in the vent and drain connections do not include nozzle pressure losses.

Use a reliable manometer to measure pressure differential when determining water flow. Regular gages are insensitive and do not provide accurate measurement of flow conditions.



PRESSURE GAGE LOCATION

NUMBER OF PASSES	GAGE LOCATION (Cooler or Condenser)
1 and 3	One gage in each waterbox.
2	Two gages in waterbox with nozzles.

Refrigerant temperature sensors

All 19EX chillers are supplied with evaporator and condenser temperature sensors.

Thermometers

Recommended ranges for water temperature thermometers are:

Entering and leaving chilled water, 20 F to 80 F (-7 to 27 C);

Entering and leaving condenser water, 30 F to 120 F (-1 to 49 C)

Thermometers for measuring chilled water and condensing water temperatures are field purchased, as required, for individual jobs. It is recommended that thermometer wells be provided in cooler and condenser water piping. Wells in the leaving water pipes should be 6 to 10 pipe diameters from the waterboxes. This provides sufficient distance for complete mixing of water as it leaves the heat exchanger tubes. Extend thermometers into pipe at least 2 in. (51 mm).

Relief devices

The 19EX is equipped with 7 relief valves as standard. The quality of devices and the outlet connection size of each valve is listed in the Relief Valve Data table below:

RELIEF VALVE DATA

LOCATION	OUTLET SIZE	
	1 1/4 in. FPT	3/8 in. Male Flare
	No. of Valves	
Cooler	4*	—
Economizer/Storage Vessel	2*	—
Pumpout Unit Condenser	—	1

*To ensure relief valve serviceability, and as required in ASHRAE 15, three-way valves and redundant relief valves are installed. Only one half of the "No. of Valves" listed are in service at any time.

Relief-valve discharge piping sizing should be calculated per the current version of the ASHRAE 15 (American Society of Heating, Refrigeration, and Air Conditioning Engineers) code using the tabulated C-factors in the Relief-Valve Discharge Piping table shown below.

Carrier further recommends that an oxygen sensor be installed to protect personnel. The sensor should be of a type that senses the depletion or displacement of oxygen in the machine room below 19.5% volume oxygen per ASHRAE 15, latest edition.

AUXILIARY CONNECTIONS

SIZE AND STYLE	USAGE
1/2 in. NPT Conduit	Power Panel Oil Pump Power Connection
1 1/4 in. FPT	Cooler Relief Valve Connection
1 1/4 in. FPT	Economizer/Storage Vessel Connection
1/2 in. FPT	Pumpout Water Inlet Connection
1/2 in. FPT	Pumpout Water Outlet Connection
3/8 in. Male Flare	Pumpout Condenser Refrigerant Vapor Connection (Rupture Disc)
3/4 in. NPT	Waterbox Vent Connection
1 in. NPT	Waterbox Drain Connection

ASME stamping

All 19EX heat exchangers are constructed in accordance with ASHRAE 15 Safety Code for Mechanical Refrigeration (latest edition). This code, in turn, requires conformance with ASME (American Society of Mechanical Engineers) Code for Unfired Pressure Vessels whenever applicable.

RELIEF-VALVE DISCHARGE PIPING

RELIEF VALVE LOCATION	HEAT EXCHANGER SIZES	REQUIRED C FACTOR (lb air/min.)	NOMINAL OUTLET PIPE SIZE (IN. FPT)	RATED RELIEF PRESSURE
Cooler	Frame 3	139.7	1 1/4	225 psig (1551 kPa)
Cooler	Frame 4	158.8	1 1/4	225 psig (1551 kPa)
Economizer/Storage Vessel	All	64.2	1 1/4	255 psig (1551 kPa)
Pumpout Unit Condenser	All	1.5	3/8 in. Male Flare	385 psig (2655 kPa)

NOTES:

- The cooler relief C-factor is for both cooler and condenser vented through the cooler in accordance with ASHRAE 15.
- Relief valve discharge pipe sizing is to be calculated per latest version of ASHRAE 15, using the tabulated C-factors and nominal pipe size listed above. Rated relief valve pressure is 225 psig (1551 kPa).

- The pumpout condenser contains less than 110 lb (50 kg) of HFC-134a, which is a Group A1 refrigerant. The ASHRAE 15 standard exempts small-volume vessels from the requirement to vent outside. However, Carrier recommends that the pumpout condenser be connected to the rest of the vent system.

Application data (cont)



HEAT EXCHANGER MINIMUM/MAXIMUM FLOW RATES* ENGLISH (Gpm)

FRAME SIZE	COOLER SIZE	1 PASS		2 PASS		3 PASS	
		min	max	min	max	min	max
3	31	1971	7,885	986	3942	657	2628
	32	2218	8,870	1109	4435	739	2957
	33	2464	9,856	1232	4928	821	3285
4	41	2710	10,842	1355	5421	903	3614
	42	2957	11,827	1478	5914	986	3942
	43	3203	12,813	1602	6406	1068	4271

FRAME SIZE	CONDENSER SIZE	1 PASS		2 PASS		3 PASS	
		min	max	min	max	min	max
3	31	2026	8,104	1013	4052	675	2701
	32	2279	9,117	1140	4559	760	3039
	33	2533	10,130	1266	5065	844	3377
4	41	2786	11,143	1393	5572	929	3714
	42	3039	12,156	1520	6078	1013	4052
	43	3292	13,169	1646	6585	1097	4390

FRAME SIZE	COOLER SIZE	SI (L/sec)		2 PASS		3 PASS	
		min	max	min	max	min	max
3	31	124	497	62	249	41	166
	32	140	560	70	280	47	187
	33	155	622	78	311	52	207
4	41	171	684	85	342	57	228
	42	187	746	93	373	62	249
	43	202	808	101	404	67	269

FRAME SIZE	CONDENSER SIZE	1 PASS		2 PASS		3 PASS	
		min	max	min	max	min	max
3	31	128	511	64	256	43	170
	32	144	575	72	288	48	192
	33	160	639	80	320	53	213
4	41	176	703	88	351	59	234
	42	192	767	96	383	64	256
	43	208	831	104	415	69	277

*Flow rates are based on standard tubes, cooler and condenser, and marine waterboxes. Minimum flow based on tube velocity of 3 ft/sec (0.9 m/sec); maximum based on 12 ft/sec. (3.6 m/sec).

MACHINE CONTACT SURFACES (cont)

SOLEPLATE ISOLATION

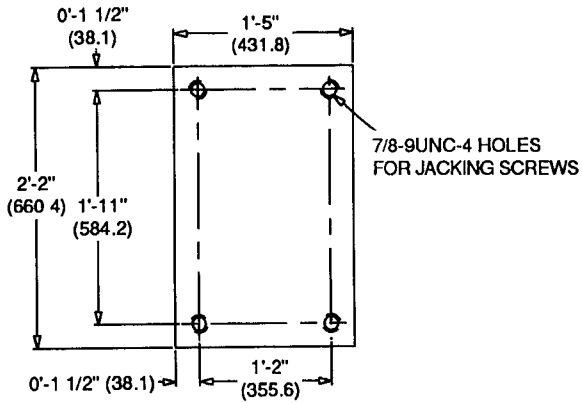

TYPICAL ISOLATION

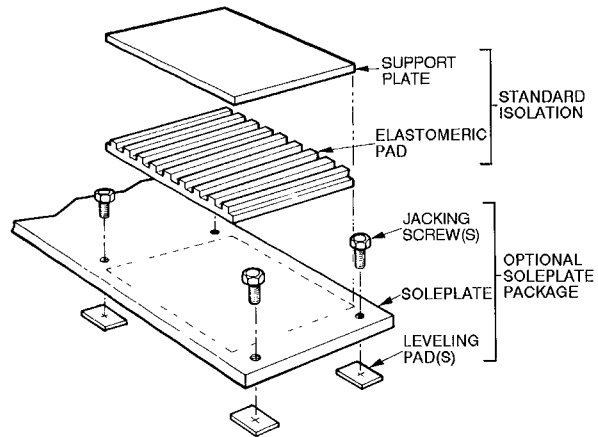

OPTIONAL ISOLATION SOLEPLATE DETAIL SECTION A-A

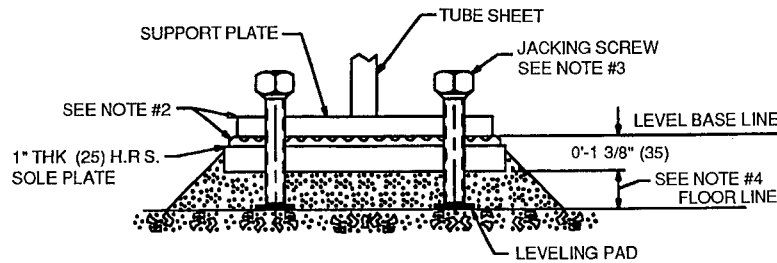

NOTES:

1. Dimensions in () are in millimeters
2. Optional soleplate package includes 4 soleplates, 16 jacking screws and leveling pads. Requires isolation package.
3. Jacking screws to be removed after grout has set
4. Thickness of grout will vary, depending on the amount necessary to level chiller. Use only pre-mixed non-shrinking grout, Celcote HT-648 or Master Builders 636, 0'-1 1/2" (38.1) to 0'-2 1/4" (57) thick

STANDARD ISOLATION VIEW B-B

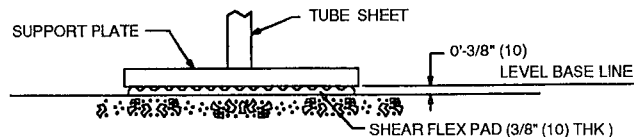

ISOLATION WITH ISOLATION PACKAGE ONLY (STANDARD)

NOTE: Isolation package includes 4 shear flex pads.

NOZZLE ARRANGEMENTS MARINE WATERBOXES

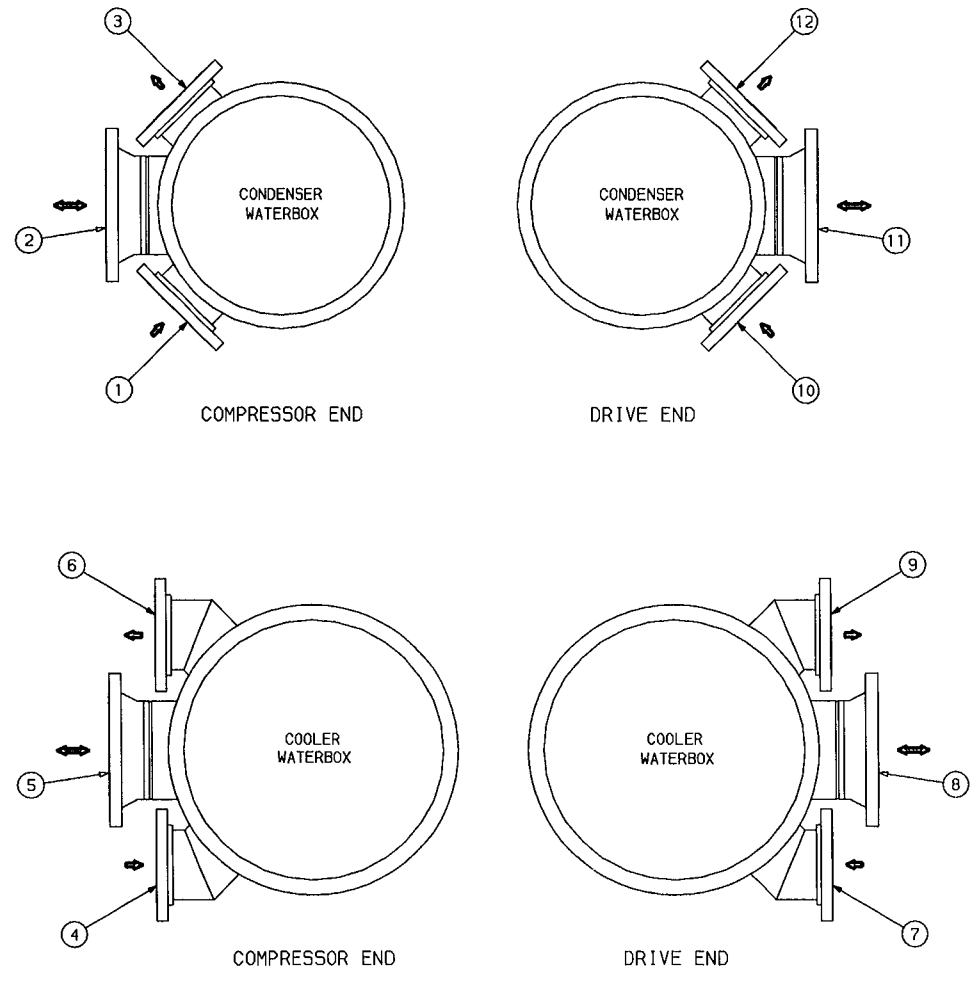

COOLER AND CONDENSER NOZZLE ARRANGEMENTS

COOLER				CONDENSER			
Pass	In	Out	Code	Pass	In	Out	Code
1	8	5	A	1	11	2	P
	5	8	B		2	11	Q
2	7	9	C	2	10	12	R
	4	6	D		1	3	S
3	7	6	E	3	10	3	T
	4	9	F		1	12	U

- NOTES:**
1. Victaulic connections are standard
 2. Flanged waterbox connections are optional
 3. Cooler/condenser nozzle code arrangements C/R and D/S are valid only for butt-weld applications

Controls



Microprocessor controls

Microprocessor controls provide the safety, interlock, capacity control, and indications necessary to operate the chiller in a safe and efficient manner.

Control system

The microprocessor control on each Carrier centrifugal system is factory mounted, wired, and tested to assure machine protection and efficient capacity control. In addition, the program logic assures proper starting, stopping, and recycling of the machine and provides a communication link to the Carrier Comfort Network (CCN).

Features

Control system

- Component Test and Diagnostic Check
- Menu-Driven Keypad Interface for Status Display, Set Point Control, and System Configuration
- CCN Compatible
- Primary and Secondary Status Messages
- Individual Start/Stop Schedules for Local and CCN Operation Modes
- Recall of Up to 25 Alarm/Alert Messages with Diagnostic Help

Safety cutouts

- Bearing Oil High Temperature*
- Motor High Temperature*†
- Refrigerant (Condenser) High Pressure*†
- Refrigerant (Cooler) Low Temperature*†
- Lube Oil Low Pressure††
- Compressor (Refrigerant) Discharge Temperature*
- Under Voltage††
- Over Voltage††
- Oil Pump Motor Overload
- Cooler and Condenser Water Flow**
- Motor Overload†
- Motor Acceleration Time
- Intermittent Power Loss||
- Compressor Starter Faults
- Compressor Surge Protection*

Capacity Control

- Leaving Chilled Water Control
- Entering Chilled Water Control
- Soft Loading Control by Temperature or Load Ramping
- Guide Vane Actuator Modulation
- Hot Gas Bypass Valve
- Power (Demand) Limiter
- Auto. Chilled Water Reset

Interlocks

- Manual/Automatic Remote Start
- Starting/Stopping Sequence
 - Pre-Lube/Post-Lube
 - Pre-Flow/Post-Flow
 - Compressor Starter Run Interlock
- Pre-Start Check of Safeties and Alerts
- Low Chilled Water (Load) Recycle
- Monitor/Number Compressor Starts and Run Hours
- Manual Reset of Safeties

Indications

- Chiller Operating Status Message
- Power-On
- Pre-Start Diagnostic Check
- Compressor Motor Amps
- Pre-Alarm Alert*
- Alarm
- Contact for Remote Alarm
- Safety Shutdown Messages
- Elapsed Time (Hours of Operation)
- Chiller Input kW¶

*These can be configured by user to provide alert indication at user-defined limit.

†Override protection: Causes compressor to first unload and then, if necessary, shut down.

**Required: Field or factory supplied flow switch (installed at jobsite).

††Alert limit pre-configured. Non-adjustable.

||Will not require manual reset or cause an alarm if auto-restart after power failure is enabled

¶kW transducer must be supplied in motor starter.

MICROPROCESSOR CONTROL PANEL

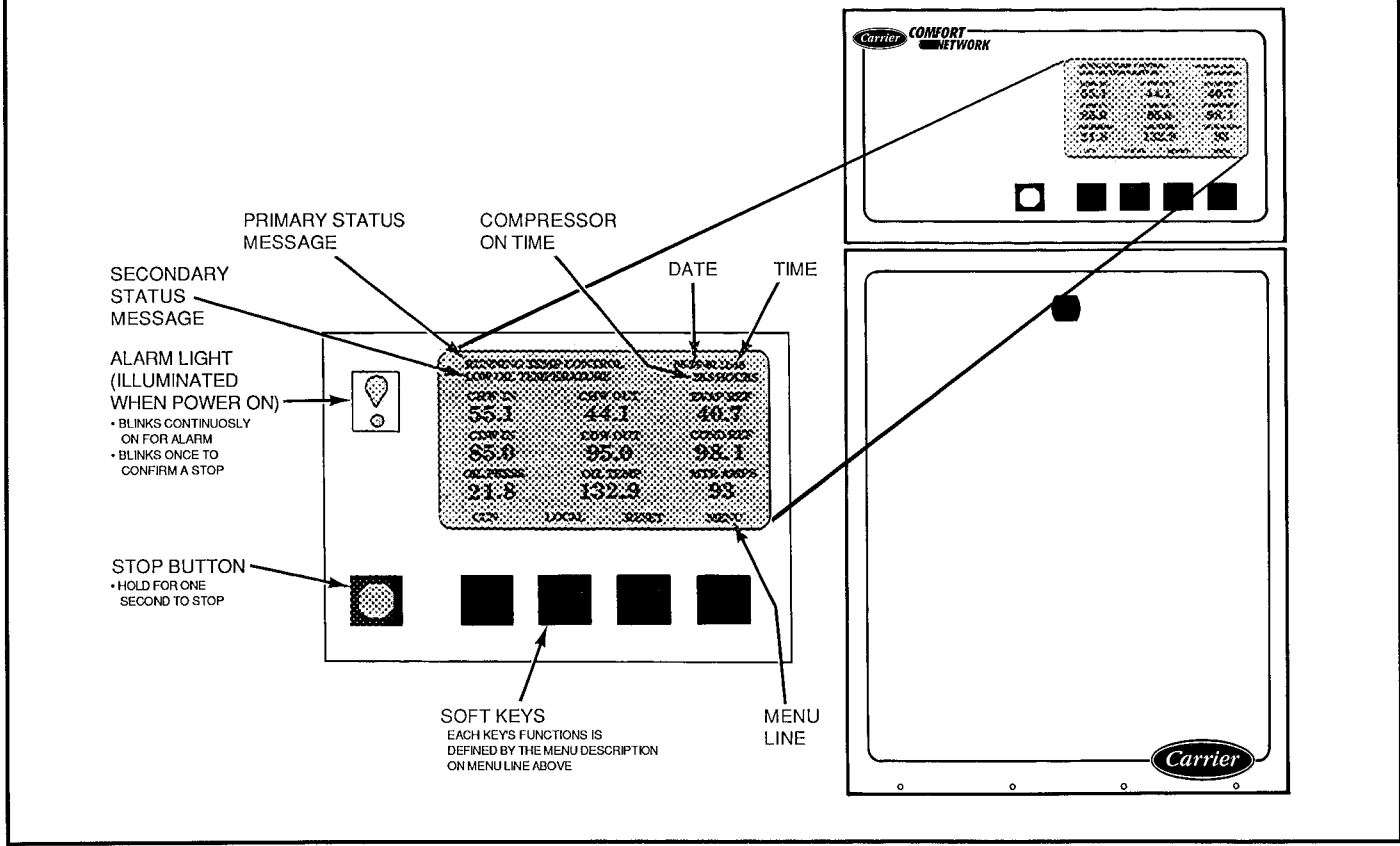

CONTROL PANEL WITH OPTIONS (Front View)

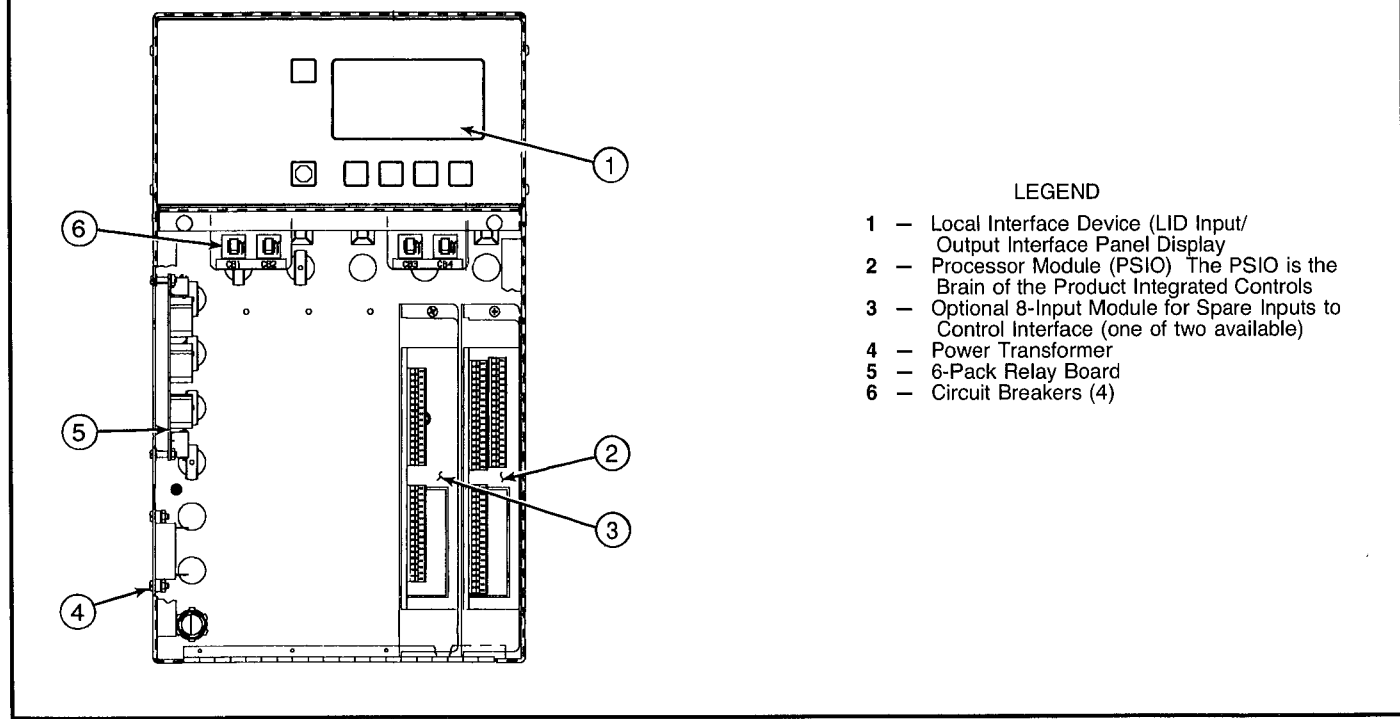

LOCAL INTERFACE DEVICE (LID) TYPICAL DISPLAY PANELS

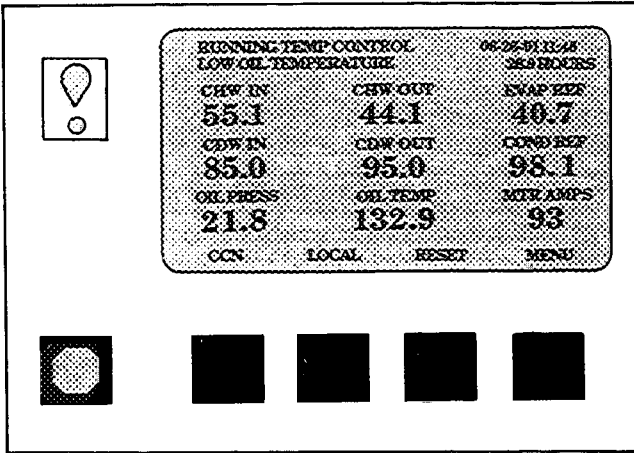

Default Display — Displays information most commonly required for chiller operating logs. Two line system status messages inform the operator of mode of operation or any alert or alarm messages. The four "softkeys" allow access to other control functions.

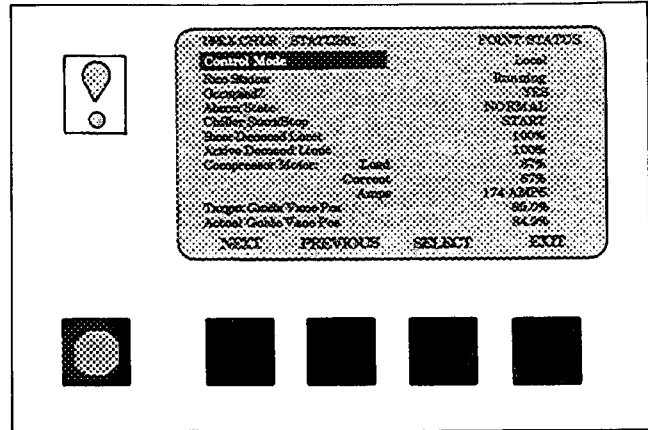

Status Screens — Displays readings of every point monitored by the microprocessor. Cooler, condenser, and oil pressure are included in the status screens.

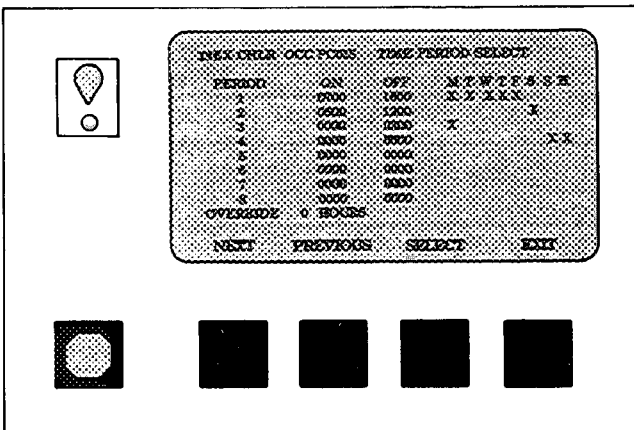

Schedule Screen — A user established occupancy schedule can easily be configured for your particular application. A 365-day, real time, battery backed up clock will automatically start and stop the chiller according to your established schedule, or per the building master schedule in a CCN system.

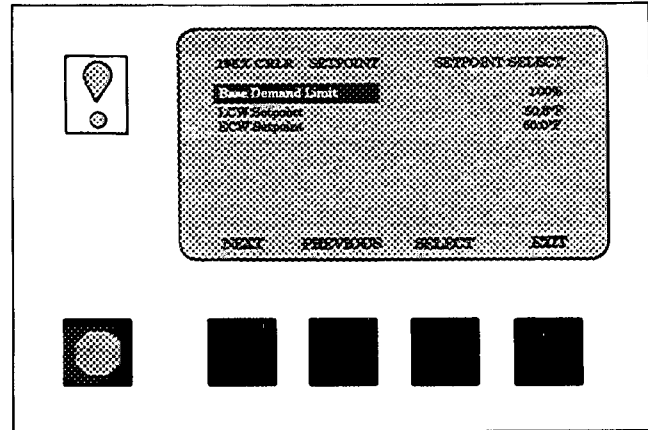

Set Point Screen — The chilled water and demand limit set points can be entered, stored, viewed, or changed easily from this screen.

LOCAL INTERFACE DEVICE (LID) TYPICAL DISPLAY PANELS (cont)

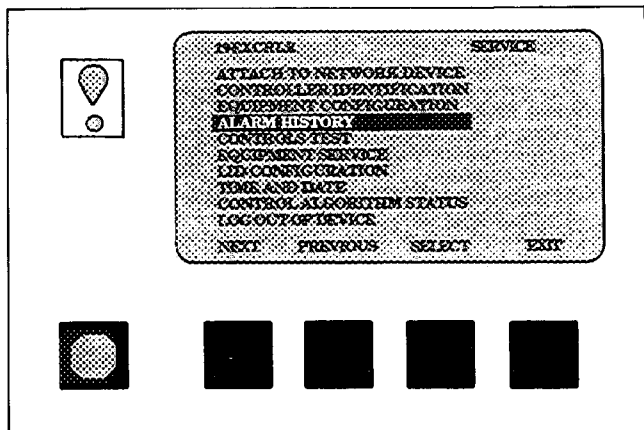

Service Screens — The password protected service screens provide an array of information available to configure the chiller for your particular application and troubleshoot any problems that may occur

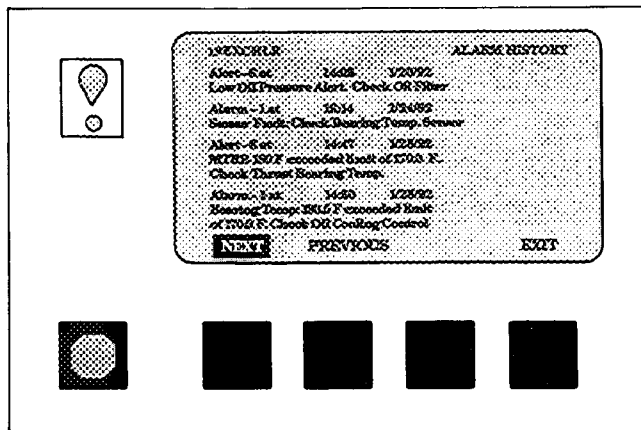

Alarm History File — Stores last 25 alarms or alerts that have occurred along with time and date indication. Allows service technician to quickly review alarm or alert history to identify problems that exist as well as action required to resolve the problem.

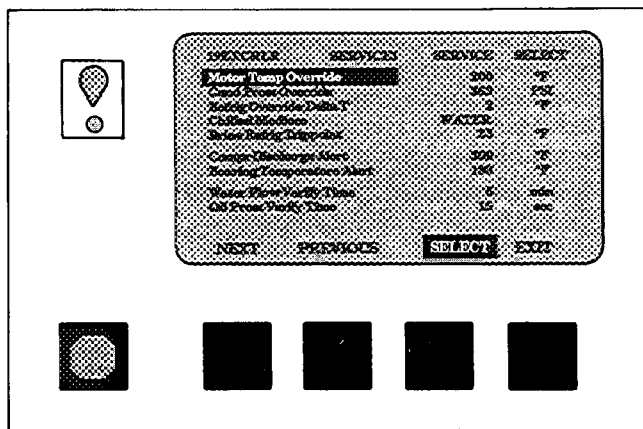

The Service Configuration Screens — Allow configuration of the controls for your particular application and setting override and alert levels for several points monitored by the control system.

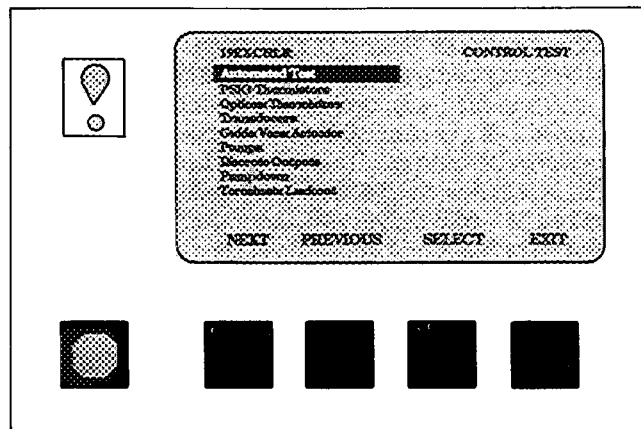

The Controls Test Screen — Allows access to the various controls tests available to the service technician to quickly identify sources of problems and to get the chiller back on line rapidly

Controls (cont)

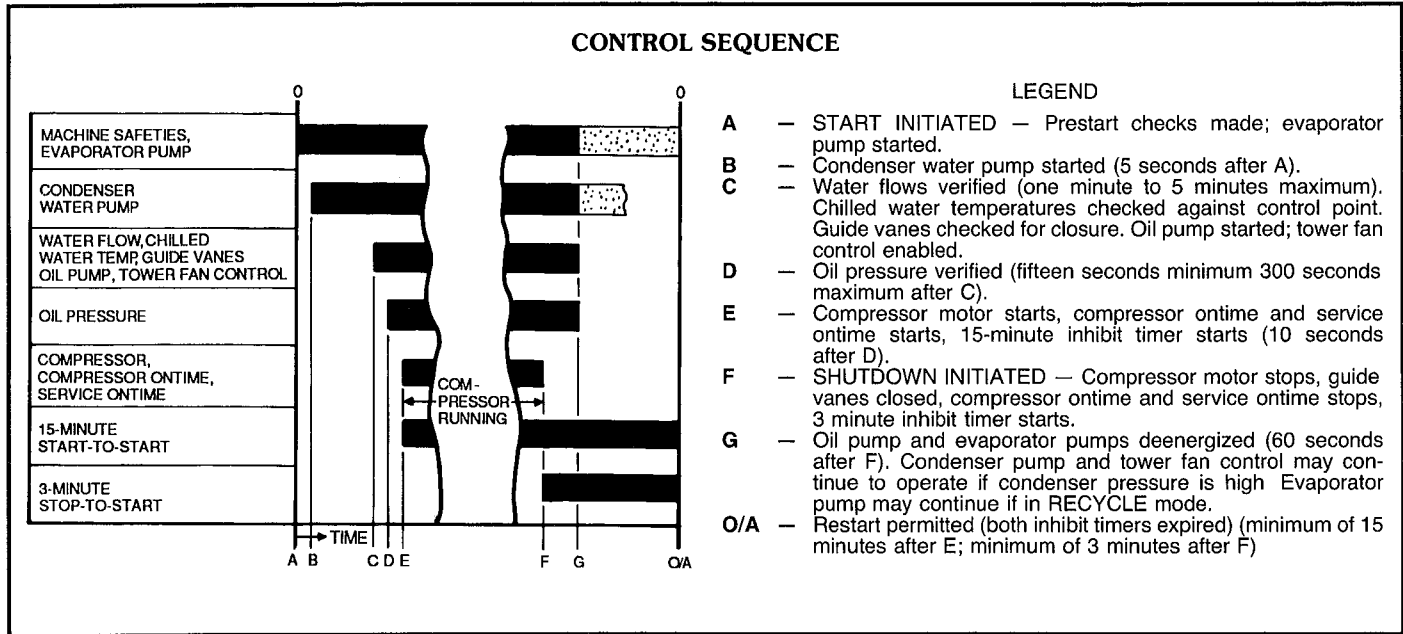

Control sequence

To start: Local start-up (manual start-up) is initiated by pressing the LOCAL menu softkey which is indicated on the default local interface device (LID) screen. Time schedule 01 must be in the occupied mode and the internal 15 minute start-to-start and the 3-minute stop-to-start inhibit timers must have expired. All pre-start alerts are checked to verify that they are within limits. If not, start-up is delayed and the reason is displayed until conditions are within limits. All safeties are checked to verify if they are confirmed within limits (if one is not an indication of the fault will be displayed and the start aborted) The signal is sent to start the chilled water pump. Five seconds later, the condenser water pump is energized, and the tower fan control is enabled. One minute later the controls check to see if flow has been confirmed by the closure of the chilled water and condenser water flow switches. If not confirmed, it will continue to monitor flows for a maximum of five minutes. When confirmed, it checks the chilled water temperature against the control point. If the temperature is less than or equal to the control point the condenser water pump will turn off and the controls will go into a recycle mode.

If the water/brine temperature is high enough the start-up sequence continues on to check the guide vane position. If the guide vanes are more than 6% open, start-up waits until the vanes are closed. If the vanes are closed, and the oil pump pressure is less than 3 psi (21 kPa), the oil pump will be energized. The controls will wait 15 seconds for the oil pressure to reach 15 psi (103 kPa). After oil pressure is verified, the controls wait 10 seconds, and then the compressor start relay is energized to start the compressor. Compressor ontime and service ontime "timers" start and the 15 minute start-to-start timer will start 10 seconds after oil pressure was verified.

Once started: The controls will enter the ramp loading mode to slowly open the guide vanes to prevent a rapid increase in compressor power consumption. Once completed, the controls will enter the capacity control mode. Any failure after the compressor is energized that results in a safety shutdown, will energize the alarm light, advance the starts in 12 hours counter by one, and display the applicable shutdown status on the local interface device (LID) display screen.

Shutdown sequence: Shutdown of the chiller can occur if any of the following events happen:

- The stop button is pressed for at least one second
- A recycle shutdown was initiated
- Time schedule has gone into unoccupied mode
- Machine or starter protective limit has been reached and machine is in alarm
- The start/stop status is overridden to stop from the CCN network or LID

Once the controls are placed in shutdown mode, the shutdown sequence first stops the compressor by deactivating the start relay. The guide vanes are then brought to the closed position. Compressor ontime and service ontime stops. The 3 minute stop-to-start will not start to count down. The oil pump relay and chilled water/brine pump are shut down 60 seconds after the compressor stops. The condenser water pump will be shut down when the refrigerant temperature or entering condenser water are below preestablished limits.

If the compressor motor load is greater than 10% after shutdown, or the starter contacts remain energized, the oil pump and chilled water pump remain energized and the alarm is displayed.

Restart: Restart is permitted after both inhibit timers have expired. If shutdown was due to a safety shutdown the reset button must be depressed prior to restarting the chiller.

Typical control wiring

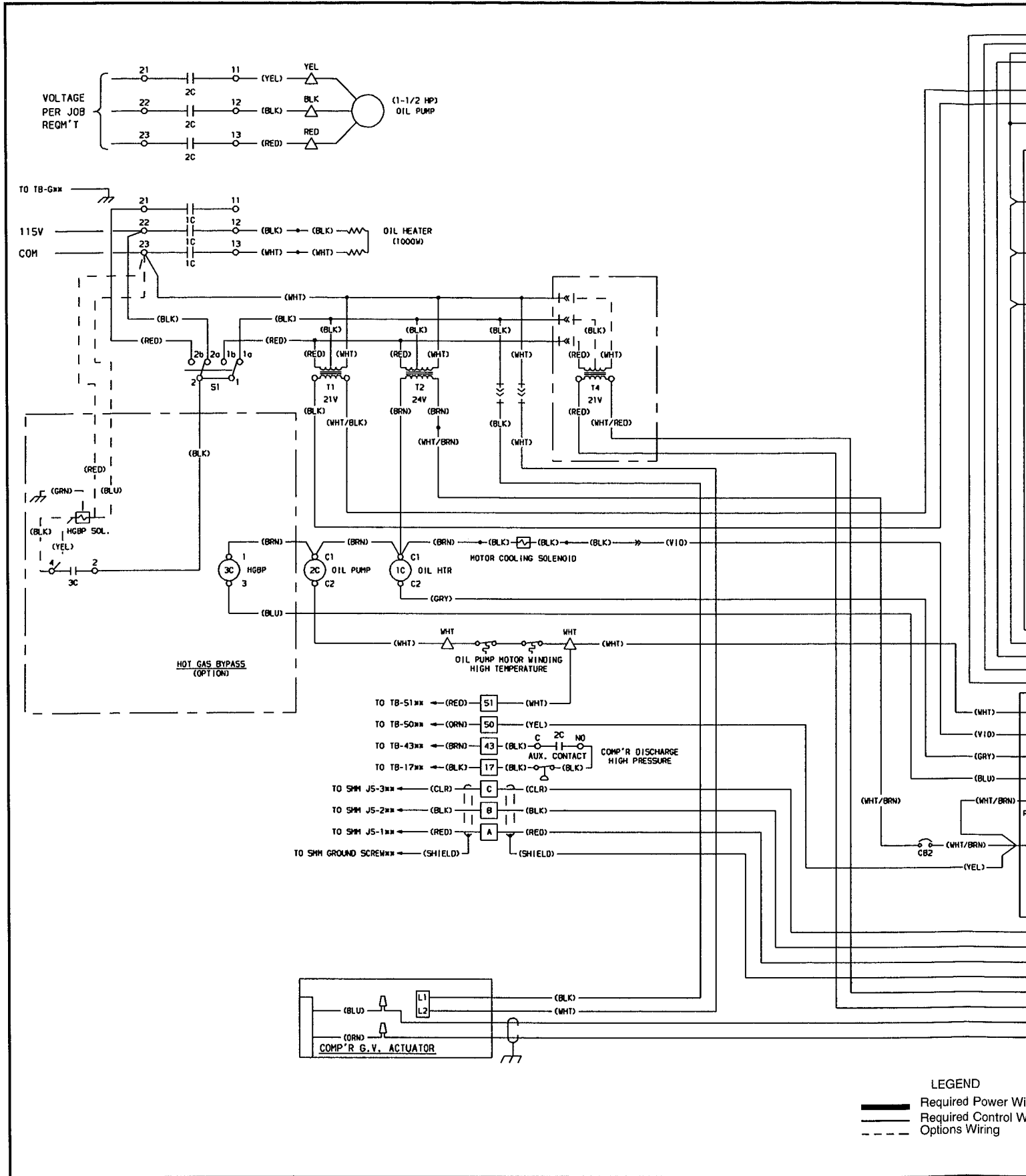

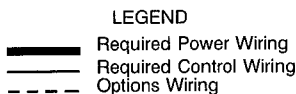
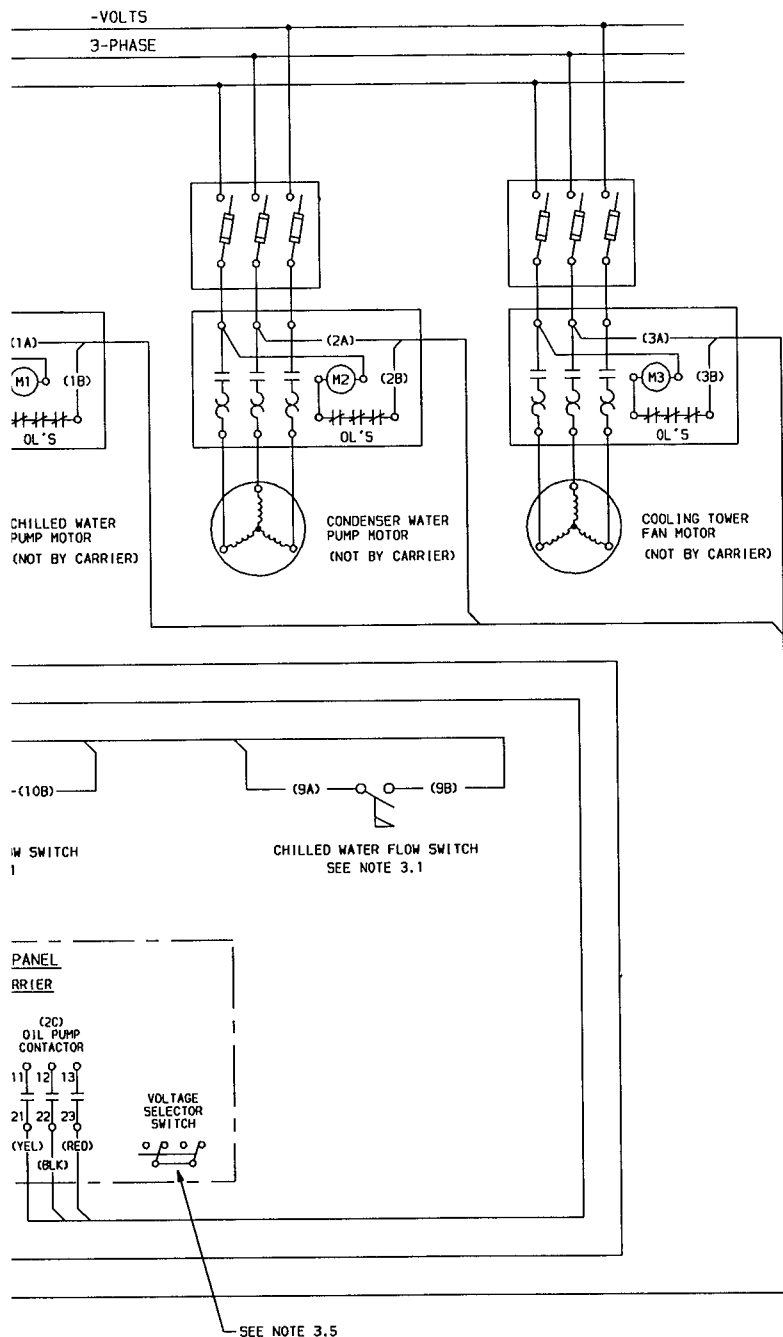

NOTES:

I GENERAL

- 10 Starters shall be designed and manufactured in accordance with Carrier Engineering requirement Z-375
- 11 All field-supplied conductors, devices and the field-installation wiring, termination of conductors and devices, must be in compliance with all applicable codes and job specifications
- 12 The routing of field-installed conduit and conductors and the location of field-installed devices, must not interfere with equipment access of the reading, adjusting, or servicing of any component
- 13 Equipment installation and all starting and control devices must comply with details in equipment submittal drawings and literature
- 14 Contacts and switches are shown in the position they would assume with the circuit deenergized and the chiller shut down
- 15 **WARNING:** Do not use aluminum conductors.
- 16 Installer is responsible for any damage caused by improper wiring between starter and machine

II POWER WIRING TO STARTER

- 20 Power conductor rating must meet minimum unit nameplate voltage and compressor motor RLA (rated load amps)
When (3) conductors are used:
Minimum ampacity per conductor = 1.25 x compressor RLA
When (6) conductors are used:
Minimum ampacity per conductor = 0.721 x compressor RLA
- 21 Lug adapters may be required if installation conditions dictate that conductors be sized beyond the minimum ampacity required. Contact starter supplier for lug information
- 22 Compressor motor and controls must be grounded by using equipment grounding lugs provided inside starter enclosure.

III CONTROL WIRING

- 30 Field supplied control conductors to be at least 18 AWG (American Wire Gauge), or larger
- 31 Chilled water and condenser water flow switch contacts, optional remote start device contacts, and optional spare safety contacts must have 24 vdc rating. Maximum current is 60 ma, nominal current is 10 ma. Switches with gold plated bifurcated contacts are recommended
- 32 Remove jumper wire between 12A and 12B before connecting auxiliary safeties between these terminals
- 33 Pilot relays can control cooler and condenser pump and tower fan motor contactor coil loads rated 10 amps at 115 vac up to 3 amps at 600 vac. Do not use starter control transformer as the power source for pilot relay loads.
- 34 Do not route control wiring carrying 30 v or less within a conduit which has wires carrying 50 v or higher or along side wires carrying 50 v or higher
- 35 Voltage selector switch in machine power panel is factory set for 115 v control and oil heater power source. If switch is set to 230 v position, oil heater will not function
- 36 Control wiring cables between starter and power panel must be shielded with minimum rating of 600 v, 80 C. Ground shield at starter
- 37 If optional oil pump circuit breaker is not supplied within the starter enclosure as shown, it must be located within sight of the machine with wiring routed to suit

IV POWER WIRING BETWEEN STARTER AND COMPRESSOR MOTOR

- 40 Medium voltage (over 600 volts) compressor motors have 3 terminals. Connections out of terminals are 3 in. long no. 4 stranded wire pigtails. Use suitable splice connectors and insulation for high-voltage alternating current cable terminations (these items are not supplied by Carrier). Compressor motor starter must have nameplate stamped as to conforming with Carrier requirement Z-375.
- 41 When more than one conduit is used to run conductors from starter to compressor motor terminal box, one conductor from each phase must be in each conduit, to prevent excessive heating, (e.g., conductors to motor terminals 1, 2, and 3 in one conduit, and those to 1, 2, and 3 in another)
- 42 Compressor motor power connections can be made through top of compressor motor terminal box by using holes cut by contractor to suit conduit. Flexible conduit should be used for the last few feet to the terminal box for unit vibration isolation. Use of stress cones or 12 conductors larger than 500 MCM may require an oversize (special) motor terminal box (not supplied by Carrier)
- 43 Compressor motor frame to be grounded in accordance with the National Electrical Code (NFPA-70) and applicable codes. Means for grounding compressor motor is (1) pressure connector for 300 to 800 MCM wire, supplied and located in the lower left side corner of the compressor motor terminal box
- 44 Do not allow motor terminals to support weight of wire cables, use cable supports and strain reliefs as required

Typical piping and wiring



19EX CHILLER WITH FREE-STANDING STARTER

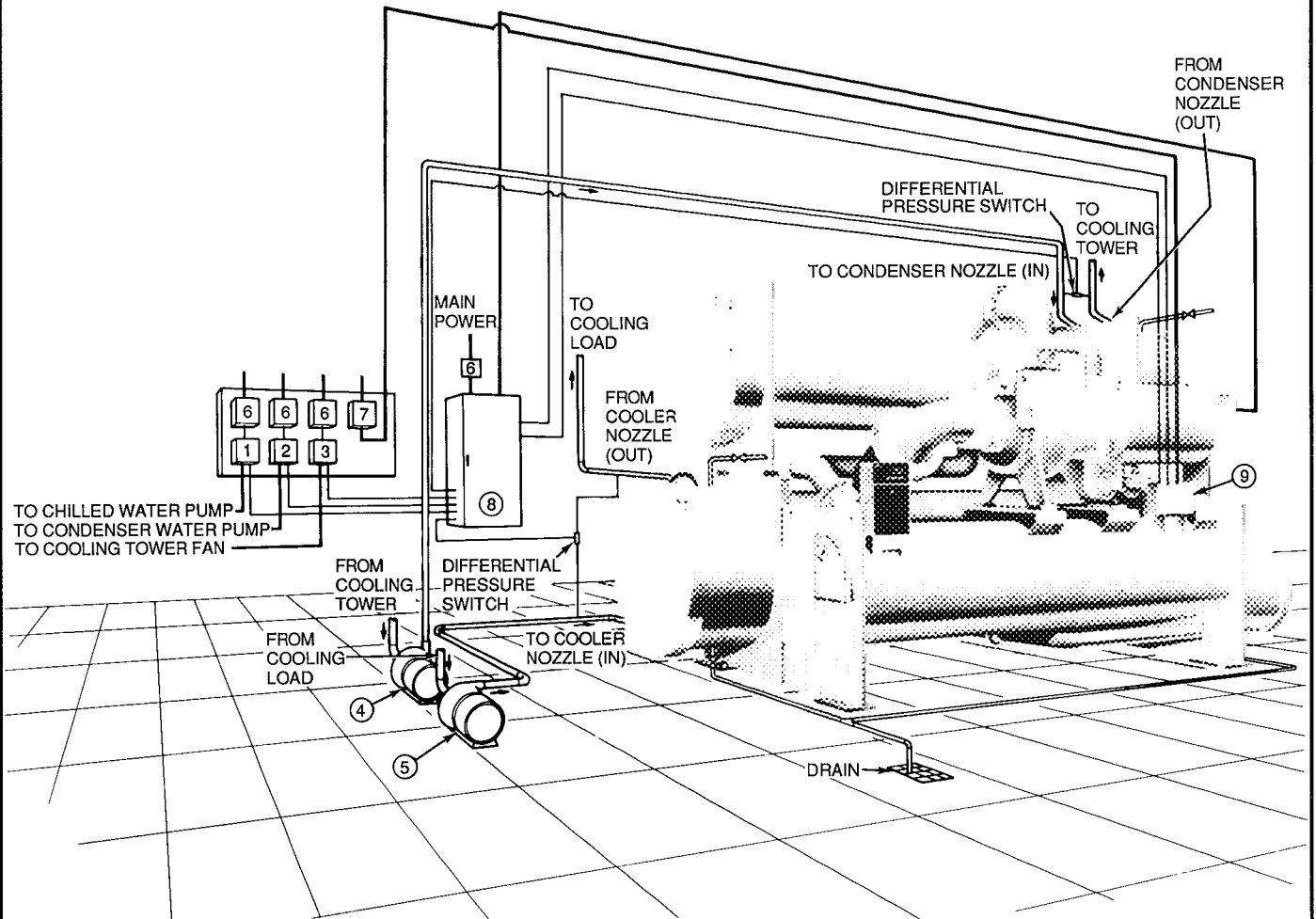

LEGEND

- 1 — Chilled Water Pump Starter
- 2 — Condenser Water Pump Starter
- 3 — Cooling Tower Fan Starter
- 4 — Condenser Water Pump
- 5 — Chilled Water Pump
- 6 — Disconnect
- 7 — Oil Pump Disconnect (See Note 5)
- 8 — Freestanding Compressor Motor Starter
- 9 — Chiller Auxiliary Power Panel
- Piping
- Control Wiring
- Power Wiring

NOTES:

- 1 Wiring and piping shown are for general point-of-connection only and are not intended to show details for a specific installation. Certified field wiring and dimensional diagrams are available on request.
- 2 All wiring must comply with applicable codes.
- 3 Refer to Carrier System Design Manual for details regarding piping techniques.
- 4 Wiring not shown for optional devices such as:
 - Remote Start/Stop
 - Remote Alarms
 - Optional Safety Device
 - 4 to 20 mA Resets
 - Optional Remote Sensors
- 5 Oil pump disconnect may be located within the enclosure of Item 8 — Freestanding Compressor Motor Starter.

Guide specifications



Hermetic Centrifugal Chiller

Size Range: **800 to 1300 Tons**
(2810 – 4570 kW) Nominal

Carrier Model Number: **19EX**

Part 1 – General

1.01 SYSTEM DESCRIPTION

- A. Microprocessor controlled liquid chiller utilizing two-stage hermetic centrifugal compressor with HFC-134a refrigerant. Chillers using CFC refrigerants such as CFC-11, 12 or 500 are not acceptable.
- B. If a manufacturer proposes a liquid chiller utilizing HCFC-123 refrigerant, then the manufacturer shall include in the chiller price:
 1. A vapor activated alarm system consisting of all alarms, sensors, safeties, and ventilation equipment as required by ASHRAE Standard 15 (latest edition) with the quotation. System shall be capable of responding to HCFC-123 levels of 10 ppm Allowable Exposure Limit (AEL).
 2. External refrigerant storage tank and pumpout unit.
 3. High efficiency purge unit.
 4. Relief valve installed in series with rupture disk.

1.02 QUALITY ASSURANCE

- A. Chiller performance shall be rated in accordance with Air Conditioning & Refrigeration Institute (ARI) Standard 550 (latest edition).
- B. Equipment and installation shall be in compliance with Safety Code for Mechanical Refrigeration, ASHRAE 15 (latest edition)
- C. Cooler and condenser, refrigerant and water side, shall include ASME "U" stamp and nameplate certifying compliance with ASME Section VIII, Division 1 code for unfired pressure vessels.
- D. Chillers shall be designed and constructed to meet UL and CSA requirements and have labels appropriately affixed.
- E. Starter enclosure shall be NEMA 1.
- F. Compressor impellers shall be over-speed tested by manufacturer to a minimum of 20% above operating conditions.

1.03 DELIVERY, STORAGE AND HANDLING

- A. Unit shall be stored and handled in accordance with manufacturer's instructions
- B. Unit shall be shipped with all refrigerant piping and control wiring factory-installed
- C. Unit shall be shipped with firmly attached metal plates that indicate name of manufacturer, chiller model number, compressor type, and refrigerant used.

Part 2 – Products

2 01 EQUIPMENT

A. General:

Factory assembled, single-piece, liquid chillers shall consist of a hermetic compressor and motor, lubrication system, cooler, condenser, interstage flash economizer/storage vessel, vibration isolation assembly, electrical microprocessor control system, and documentation required prior to start-up. Motor starter, initial oil, and refrigerant charges shall be supplied by the chiller manufacturer for field installation

B. Compressor.

1. One centrifugal compressor of the high performance two-stage hermetic type.
2. Compressor, motor, and transmission shall be hermetically sealed into a common assembly and arranged for easy service. Connections to the compressor shall be flanged for easy disassembly.
3. Journal bearings shall be split-sleeve, steel back, babbitt-lined, and pressure lubricated.
4. Transmission gears shall be of the double helical-type and must be arranged for visual inspection without disassembly or removal of compressor casing or impeller
5. Compressor to be supplied with variable inlet guide vanes for capacity control.
6. Thrust bearing shall be tilting pad self-leveling, babbitt-lined, Kingsbury-type with equalizer piston.
7. Compressor shall be provided with a factory-installed lubrication system to deliver oil under pressure to bearings and transmission gears. Included in the system shall be:
 - a. Hermetic motor driven oil pump.
 - b. Refrigerant-cooled oil cooler.
 - c. Oil pressure regulator.
 - d. Twenty-micron oil filter with isolation valves.
 - e. Oil pump starter factory mounted on the chiller and factory wired to pump motor and control circuit.
 - f. Oil pump heater (115 v, 50 or 60 Hz) controlled from unit microprocessor.
 - g. Oil reservoir temperature sensor with main control panel digital readout.
 - h. Oil pump and motor for a separate 200-240, 380-480 or 507-619 volt, 3 phase, 60 Hz power source, (or 220-240 or 346-440 volt, 3 phase, 50 Hz power source).

C. Motor

1. Compressor motors shall be of the single speed, non-reversing, squirrel cage induction type suitable for the voltage shown on the equipment schedule.
2. Motors design speed shall be 3550 rpm at 60 Hz or 2950 rpm at 50 Hz.
3. Motors shall be suitable for operation in a refrigerant atmosphere and shall be cooled by atomized subcooled refrigerant in contact with the motor windings.
4. Motor stator shall be arranged for service or removal with only minor compressor disassembly and without breaking of main refrigerant piping connections.
5. Full load operation of the motor shall not exceed nameplate rating.
6. Low voltage motors (600 v or less) shall be built for connection to wye-delta type reduced inrush starters.

D. Cooler and Condenser:

1. Cooler and condenser shall be in separate shells Exchangers shall be fabricated with high performance copper tubing, steel shell-and-tube sheets, and fabricated steel marine waterboxes.
2. Tubing shall be copper, high-efficiency type, with integral internal and external fins. Tubes shall be nominal $\frac{3}{4}$ in OD with wall thickness of .025 or .028-in. measured at the root of the fin. Tubes shall be rolled into tube sheets, and shall be individually replaceable. End sheets shall be double grooved, for joint structural integrity. Cooler tubes shall be expanded into intermediate support sheets. Intermediate tube support sheet spacing shall not exceed 37 in (940 mm).
3. Marine waterboxes and nozzle connections shall be designed for 300 psig (2068 kPa) maximum working pressure unless otherwise noted. Nozzles should have grooves to allow for victaulic couplings.
4. The vessel shall display an ASME nameplate which shows pressure and temperature data and the "U" stamp for ASME Section VIII, Division 1.
5. Marine waterboxes shall have vents, drains, and covers to permit tube cleaning within the space shown on the drawings. Suitable tapping shall be provided in waterboxes and nozzles for control sensors, gages, and thermometers.
6. Tubes shall be removable from either end of the heat exchanger without affecting strength and durability of the tube sheet and without causing leakage in adjacent tubes.
7. The condenser shell shall include a thermal economizer which cools the condensed liquid refrigerant to a reduced temperature, thereby increasing the refrigerant cycle efficiency.
8. The tube sheets of the cooler, condenser, and economizer/storage vessel shall be bolted together to allow for field disassembly and reassembly.

E. Interstage Flash Economizer/Storage Vessel.

1. Unit shall include an interstage flash economizer/storage vessel that shall be an integral part of the chiller.
2. The vessel shall be large enough to hold the entire refrigerant charge.
3. To improve part load performance, liquid refrigerant shall be metered from the condenser to the cooler using a float type metering valve to maintain the proper liquid level of refrigerant in the heat exchangers under both full load and part load operating conditions. By maintaining a liquid seal at the flow orifice, bypassed hot gas from the condenser to the cooler is eliminated. The float valve chambers shall have bolted access covers.
4. Isolation valves shall be factory installed on the condenser liquid line, cooler liquid line, and compressor second stage suction line. These valves shall allow isolation of the refrigerant charge in the economizer/storage vessel during chiller service.

F. Insulation:

1. Chillers provided with insulation applied at the chiller manufacturer's factory shall require the chilled water piping insulated by the contractor.
2. Chillers provided with no insulation shall be insulated at the job site per manufacturer's instructions.
3. Insulation shall be $\frac{3}{4}$ -in. (19 mm) thick with a thermal conductivity not exceeding $0.28 \frac{\text{Btu} \cdot \text{in.}}{\text{hr} \cdot \text{ft}^2 \cdot ^\circ\text{F}}$ ($0.0404 \frac{\text{W}}{\text{m}} ^\circ\text{C}$) and shall conform to UL Standard 94, have classification 94 HBF.

G. Vibration Isolation:

1. Chiller manufacturer shall furnish isolator pads for mounting equipment on a level concrete pad surface
2. If the equipment room floor is not level, the chiller should be ordered with optional soleplates, jacking screws and leveling pads for field installation.

H. Controls:

1. The chiller shall be provided with a factory installed and wired microprocessor control center with individually replaceable modular components construction. Components included shall be the main processor/input-output module, power supply, starter management module (located in starter cabinet), relay board, temperature and pressure (thermistor and transducer) sensors. An optional input module (8 input channels) can be factory or field-installed. The control center includes a 16-line by 40 character liquid crystal display, 4 function keys, stop button, and alarm light. The microprocessor can be configured to display either English or SI units.

Guide specifications (cont)



2. The default standard display screen shall simultaneously indicate the following information:
 - a. Date and time of day
 - b. 24-character primary system status message
 - c. 24-character secondary status message
 - d. Chiller operating hours
 - e. Entering chilled water temperature
 - f. Leaving chilled water temperature
 - g. Evaporator refrigerant temperature
 - h. Entering condenser water temperature
 - i. Leaving condenser water temperature
 - j. Condenser refrigerant temperature
 - k. Oil differential pressure
 - l. Oil sump temperature
 - m. Percent motor rated load amps (RLA)

The default screen shall be displayed if there is no manual activity at the control console for 15 minutes.

3. The 4 function keys are identified at STATUS, SCHEDULE, SET POINT, and SERVICE.

- a. Status Functions:

- 1) Evaporator pressure
- 2) Condenser pressure
- 3) Compressor discharge temperature
- 4) Bearing oil supply temperature
- 5) Motor winding temperature
- 6) Quantity of compressor starts
- 7) Control point settings
- 8) Discrete output status of various devices
- 9) Compressor motor stater status

- b. Schedule Function:

Start-up and shutdown shall be manual or automatic. Automatic operation is activated by the user establishing an occupancy schedule based on a 365-day, real-time clock that shall automatically start and stop the chiller according to a configurable stored time. A minimum of 8 separate occupied or unoccupied periods may be scheduled by the user. The periods can have any day of the week or holiday assigned to the occupied or unoccupied periods. Up to 18 user-defined holidays can be configured up to one year in advance (month, day, and duration in days). Simultaneous display of the occupancy schedules shall be visible on the LCD screen. The chiller can also be started and stopped remotely by contact closure from a customer-supplied relay (once this option has been activated in the configuration mode), or from a building management system software command

- c. Set Point Function:

The leaving chilled water set point, entering chilled water set point, and demand limit set point shall be entered, stored, viewed, or changed by depressing the set point function key. The operator shall be able to modify these set points by entering the set point function and modifying the set points anytime during chiller operation or shutdown periods.

- d. Service Function:

By depressing the service function key and entering a 4-digit password, the operator shall be able to:

- 1) View the alarm history file which contains up to 25 alarm/alert messages with time and date stamp.
- 2) Execute the chiller controls test function for quick identification of malfunctioning components.
- 3) View/modify chiller configuration.
- 4) View/modify chiller occupancy periods.
- 5) View/modify schedule holiday periods.
- 6) View/modify schedule override periods.
- 7) View/modify system time and date.

4. Capacity control shall be by means of variable inlet guide vanes located at the impeller inlet. Load modulation shall be from 100% to 10% of full load under normal ARI conditions without the use of hot gas bypass. The guide vanes are precisely positioned by the PID (proportional-integral-derivative) control algorithm to ensure precise control ($\pm .5$ F or $.3$ C) of desired chilled water temperature without hunting or overshooting the set point.

5. The microprocessor control system shall include a programmed sequence to meet pre-lube and post-lube needs prior to machine start-up and during coast-down after machine stop. The microprocessor shall automatically activate and interlock the chilled water pump, condenser water pump, and cooling tower fans upon chiller activation.

6. Upon request to start the compressor the control system shall start the chilled water pump, condenser water pump, and enable tower fan control; verify that flow has been established; and then compare leaving chilled water temperature with the chilled water set point. If the chilled water temperature is less than the chilled water set point, the control system will shut down the condenser water pump and wait for the cooling load to be established.

7. A user-configurable ramp loading rate, effective during the chilled water temperature pulldown period, slows the rate of guide vane opening to prevent a rapid increase in compressor power consumption. Ramp loading limits the rate (degrees/minute) of chilled water temperature pulldown or percent demand limit to the user-configurable rate. During the ramp loading period, a message shall be displayed informing the operator that the chiller is operating in ramp loading mode
8. The control system shall include 2 compressor cycle-timers to protect the motor from rapid cycling. The start-inhibit timer shall prevent rapid compressor restart by limiting the start-to-start time to 15 minutes minimum and stop-to-start time to 3 minutes minimum. In addition, the compressor will be inhibited from restarting if more than 8 manual starts per 12-hour period have occurred.
9. The control system shall automatically cycle the compressor off to minimize energy usage whenever the leaving chilled water temperature is 5 F or 3 C below the desired chilled water set point. The chilled water pump will remain on, and when the leaving chilled water temperature rises above the desired set point, the compressor will automatically restart. During the shutdown period, a message shall be displayed informing the operator a recycle restart is pending.
10. The control center will monitor line voltage. If loss of voltage, high or low line voltage, or single cycle dropout is sensed, the chiller will shut down. Upon restoration of line voltage, if the auto-start after power failure algorithm was activated in the configuration mode, the chiller shall automatically restart and resume the mode of operation prior to shutdown.
11. The control center will allow reset of chilled water temperature set point based on any one of the following criteria:
 - a. Chilled water reset based on an external 4-20 mA signal.
 - b. Chilled water reset based on a remote temperature sensor (such as outdoor air).
 - c. Chilled water reset based on water temperature rise across the evaporatorWhen reset is active a message shall be displayed indicating the source of reset signal.
12. The control center will limit amp draw of the compressor to the rated load amps or to a value lower based on the following criteria:
 - a. Demand limit based on a user input ranging from 40% to 100% of compressor rated load amps.

- b. Demand limit based on an external 4-20 mA signal

When demand limit is active, a message shall be displayed indicating the source of the demand signal.

I. Safeties:

1. Unit shall automatically shut down when any of the following conditions occur: (Each of these protective limits shall require manual reset and cause an alarm message to be displayed on the LCD screen informing the operator of the shutdown cause.)
 - a. Motor overcurrent
 - b. Over voltage
 - c. Under voltage
 - d. Single cycle dropout
 - e. Bearing oil high temperature
 - f. Low evaporator refrigerant temperature
 - g. High condenser pressure
 - h. High motor temperature
 - i. High compressor discharge temperature
 - j. Low oil pressure
 - k. Prolonged surge
 - l. Loss of cooler water flow
 - m. Loss of condenser water flow
 - n. Starter fault
2. The control system shall detect conditions which approach protective limits and take self-corrective action prior to an alarm occurring. The system shall automatically reduce chiller capacity when any of the following is out of normal operating range:
 - a. High condenser pressure
 - b. High motor temperature
 - c. Low evaporator refrigerant temperature

During the capacity override period, a pre-alarm (alert) message shall be displayed informing the operator which condition is causing the capacity override. Once the condition is again within acceptable limits, the override condition shall be terminated and the chiller will revert to normal chilled water control. If during either condition the protective limit is reached, the chiller will shut down and a message will be displayed informing the operator which condition caused the shutdown and alarm

J. Diagnostics and Service:

1. The control system shall execute a series of pre-start checks whenever a start command is received to determine if pressures, temperatures, and times are within normal limits, thereby allowing a normal start-up to commence. If any of the limits are exceeded, an alert message will be displayed informing the operator of the cause of the prestart alert.

Guide specifications (cont)



2. A self-diagnostic controls test shall be an integral part of the control system to allow quick identification of malfunctioning components. Once the controls tests has been initiated, all pressure and temperature sensors shall be checked to ensure they are within normal operating range. A pump test will automatically energize the chilled water pump, condenser water pump, and oil pump. The control system will confirm that water flow and oil pressure have been established and require operator confirmation prior to proceeding to the next test. A guide vane actuator test shall open and close the guide vanes to check for proper operation. The operator manually acknowledges proper guide vane operation prior to proceeding to the next test.

In addition to the automated controls test, a thermistor test and transducer test shall allow display on the LCD screen of the actual reading of each transducer and each thermistor installed on the chiller. All sensors will have quick disconnects to allow replacement of the sensor without replacement of the entire sensor wire.

K. Building Control System Interface

The chiller control system shall have the ability to interface and communicate directly to the building control system without the use of additional field installed hardware or software. The building control system and the centrifugal chiller must be supplied by the same manufacturer.

L. Multiple Chiller Control:

Multiple chiller installations shall be capable of being regulated by the addition of a multiple chiller control module, field-installed, located in the control center of one of the chillers and does not require any additional hardware, software, or human interface to operate. If desired, other components of the chilled water plant, such as towers, pumps, and valves can be controlled by hardware and software supplied by the chiller manufacturer, coordinated with the Chillervisor System Manager (CSM).

M. Electrical Requirements:

Electrical Contractor shall:

1. Handle and install the compressor motor starter in accordance with the diagrams and instructions of the chiller manufacturer.
2. Supply and install all electric lines, disconnect switches, circuit breakers, electrical protection devices, and motor terminal lugs.
3. Wire the water flow switches in the control circuit to ensure that chiller will not operate until flows are established and maintained.
4. Supply electrical power to the oil pump starter and oil heater contactor terminals with the characteristics as noted in the equipment schedule. Supply shall be independent of main compressor motor breaker or disconnect.

5. Supply electrical power to the unit at the voltage, phase, and frequency listed in the equipment schedule.

N. Piping Requirements:

Mechanical Contractor shall:

1. Supply and install the water piping to the nozzles of the cooler and condenser and shall make provisions for removal and replacement of piping when required to provide access for cleaning of cooler and condenser tubes.
2. Make water connections to all water supply drain and vent connections as required by equipment drawings and local codes.
3. Supply and install refrigerant vent (relief) lines to outdoors as required on equipment drawings.
4. Supply and install pressure gages in readily accessible locations in piping adjacent to the chiller such that they can be easily read from a standing position on the floor. Gages shall be Marsh Master or equal with 4½-in. (114 mm) nominal diameter dial face. Scale range shall be such that design values shall be indicated at approximately mid-scale. Gages shall be installed in the entering and leaving water lines to the cooler and condenser.
5. Supply and install thermometers in readily accessible locations in piping adjacent to the chiller such that they can be easily read from a standing position on the floor. Thermometers shall be Moeller or equal; adjustable, mercury-filled with 7-in. (178 mm) long glass-faced metal cases, separable sockets and wells. Bulbs shall project sufficiently into the pipe to accurately measure fluid temperature. Cases shall have extensions of sufficient length to clear insulation. Thermometers shall be installed in the entering and leaving water lines to the cooler and condenser.
6. Supply and install United Electric differential pressure switches or equal flow switches in chilled water and condenser water piping. Switches shall make contact when flow is established. Flow switches shall be installed in horizontal runs at least five pipe diameters downstream from any bend or tee.

O. Start-up:

1. The chiller manufacturer shall provide a factory-trained representative, employed by the chiller manufacturer, to perform the start-up procedures as outlined in the Start-Up, Operation and Maintenance manual provided by the chiller manufacturer.
2. After the above services have been performed, the same factory-trained representative shall be available for a period of classroom instruction not to exceed an 8-hour day to instruct the owner's personnel in the proper operation and maintenance of the chiller.

3. Contractor shall supply the owner with the following literature as furnished by the manufacturer prior to start-up:
 - a. One complete set of installation drawings.
 - b. Installation Instructions
 - c. Start-Up, Operation and Maintenance Instructions.
 - d. Field wiring diagrams.

P Field-Installed Accessories:

The following standard accessories are available for field installation:

1. Soleplate Package — Unit manufacturer shall furnish a soleplate package consisting of soleplates, jacking screws, leveling pads and neoprene pads.
2. Spring Isolators — Field furnished and selected for the desired degree of isolation
3. Spare Sensors with Leads — Unit manufacturer shall furnish additional temperature sensors and leads to be used in conjunction with the controls options module kit.
4. Control Options Module Kit — Unit manufacturer shall furnish an 8 input control module required to provide chilled water reset from 4-20 mA signal or remote temperature sensor, auto demand limit from 4-20 mA signal, or monitoring common supply and return chilled water temperature for multiple chiller control. Accessory includes options transformer for installation in power panel. The 8-input module shall be capable of generating a 20 mA current supply for modulation by others or accepting a 4-20 mA input from others.

Q. Factory Installed Options:

The following standard options, if selected, are factory installed. Certain options will supersede the standard features listed previously, and are indicated by an (*).

- * 1. Insulation — Unit manufacturer shall insulate the cooler shell, cooler waterboxes, covers, compressor suction elbow, motor shell, motor cooling lines, and all interconnecting piping and tubes. Insulation shall be ¾ in. (19 mm) thick with a thermal conductivity not exceeding $0.28 \frac{\text{Btu} \cdot \text{in.}}{\text{hr} \cdot \text{ft}^2 \cdot ^\circ\text{F}}$ ($0.0404 \frac{\text{W}}{\text{m}} ^\circ\text{C}$) and shall conform to UL Standard 94, classification 94 HBF.
- * 2. Automatic Hot Gas Bypass — Hot gas bypass valve and piping, designed to artificially load the evaporator, shall be factory furnished to permit chiller operation down to 0% or full load capacity for extended periods of time.

3. Controls Option Module — Unit manufacturer shall install an 8-input control module required to provide chilled water reset from 4-20 mA signal or remote temperature sensor, auto demand limit from 4-20 mA signal or monitoring common supply and return water temperature for multiple chiller control. Option includes transformer in power panel.

* 4. Cooler and Condenser Tubes:

- a. Unit manufacturer shall provide ¾ in. outside diameter copper tubes in the condenser that are internally enhanced and have 0.028 in. wall thickness.
- b. Unit manufacturer shall provide ¾ in. outside diameter copper tubes in the cooler and/or condenser that are internally enhanced and have 0.035 in. wall thickness.
- c. Unit manufacturer shall provide ¾ in. outside diameter copper tubes in the cooler and/or condenser that are smooth bore and have 0.028 in. wall thickness
- d. Unit manufacturer shall provide ¾ in. outside diameter copper tubes in the cooler and/or condenser that are smooth bore and have 0.035 in. wall thickness.
- e. Unit manufacturer shall provide ¾ in. outside diameter 90/10 CuNi tubes in the cooler and/or condenser that are smooth bore and have 0.028 in. wall thickness
- f. Unit manufacturer shall provide ¾ in. outside diameter 90/10 CuNi tubes in the cooler and/or condenser that are smooth bore or internally enhanced and have 0.035 in. wall thickness.
- g. Unit manufacturer shall provide ¾ in. outside diameter titanium tubes in the condenser that are smooth bore and have 0.028 in. wall thickness.

* 5. Cooler and Condenser Passes:

- a. Unit manufacturer shall provide the cooler and/or condenser with 1 pass configuration on the water side.
- b. Unit manufacturer shall provide the cooler and/or condenser with 3 pass configuration on the water side.

* 6. Waterbox Covers — Unit manufacturer shall furnish waterbox covers rated at 150 psig (1034 kPa).

* 7. Flanged Water Nozzles — Unit manufacturer shall furnish standard flanged piping connections on the cooler and/or condenser

Guide specifications (cont)



8. Factory Performance Test — Unit manufacturer shall provide a certified (nonwitnessed) or witnessed single point performance test per the latest version of ARI-550 test procedures. Additional points shall be available as an option.
9. Export Crating — Unit manufacturer shall crate the unit to prevent damage which might occur with overseas shipping and handling.
10. Export Bagging — Unit manufacturer shall enclose the entire chiller within a bag to prevent rust and corrosion during shipment.
11. Pumpout System — A refrigerant pumpout system shall be installed on the chiller. The pumpout system shall include a 2-hp pumpdown compressor and drive, piping, wiring and motor. The storage vessel shall be integral to the machine, external to the unit cooler or condenser shells and shall be large enough to hold the entire refrigerant charge. Isolation of the refrigerant in the cooler or condenser during servicing is unacceptable.

