

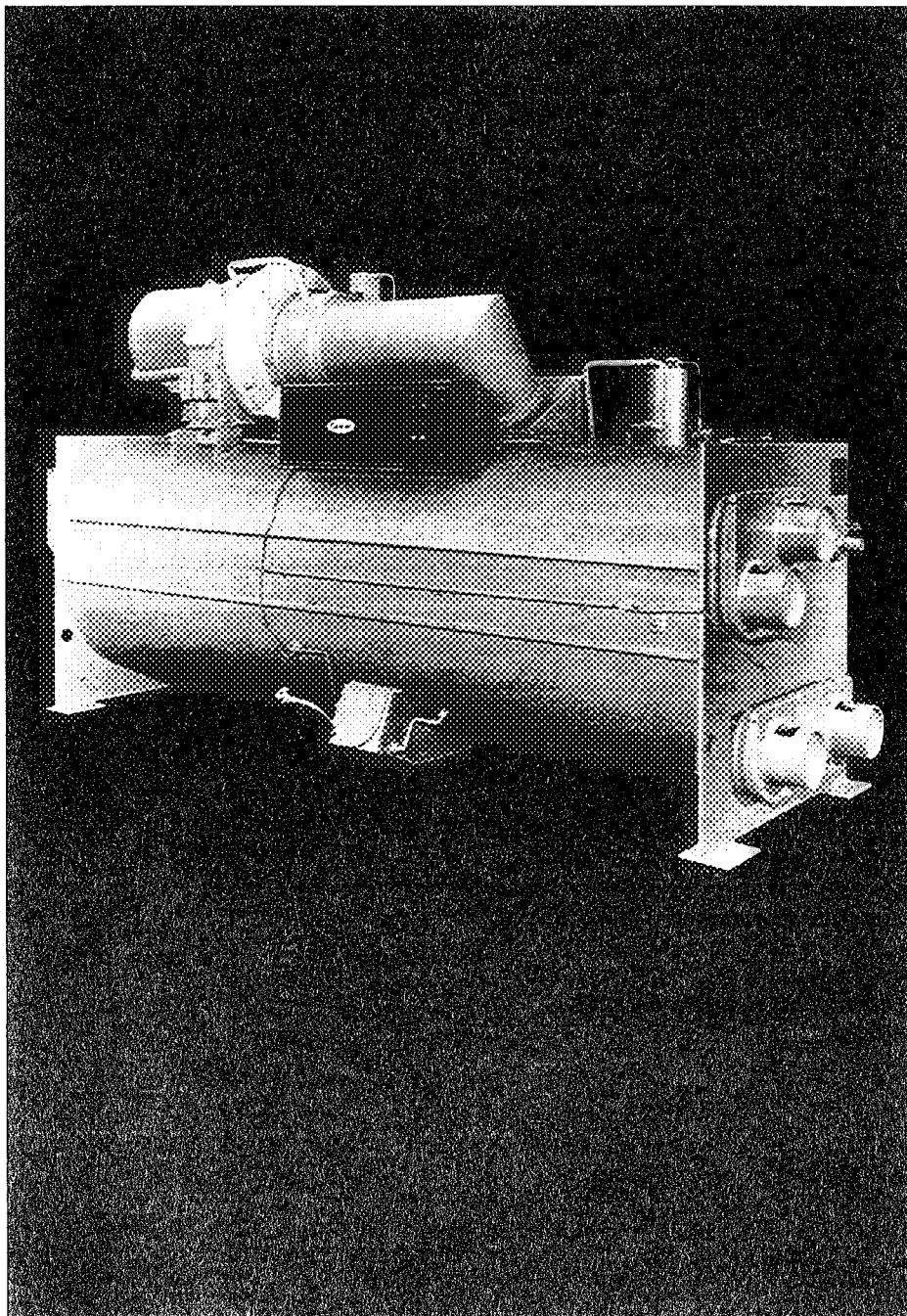

## Product Data

# 19DK,DM Packaged Hermetic Centrifugal Liquid Chiller D-1000 Series 50/60 Hz

150-500 Nominal Tons, (500-1750 kW)



Carrier's 19DK/DM hermetic centrifugal liquid chillers combine superior design and reliability with optimum operating efficiency to extend equipment life and reduce operating costs.

## Features/Benefits

**Superior design, economical, efficient cooling, and dependable performance**

**Simple and reliable single stage hermetic centrifugal compressors**

**Dynapoise® transmission** — Self-aligning Dynapoise transmission assures uniform contact of gear teeth under all operating conditions. Double helical design reduces thrust forces to assure extended life of thrust bearing surfaces.

**Industrial-type bearings** — Continuously lubricated industrial type split sleeve, steel backed bearings and multishoe kingsbury type thrust bearing provide long life and facilitate replacement.

**Hermetic motors** — Low and medium voltage, 50 and 60 Hz Carrier refrigerant cooled hermetic motors have over 20 years of operating experience. They have proven their ability to meet the rigorous starting and operating requirements of both industrial and commercial cooling applications. The hermetic design reduces plant room ventilation and periodic shaft seal maintenance costs required for open drive compressors.

**Lubrication system** — The proven Carrier oil pump, filter and cooler assembly assures proper supply of oil to all bearing surfaces during start-up, operation, and coast down. Thermo-

statically controlled oil heaters prevent excessive absorption of refrigerant into the oil during compressor shut down.

**Inlet guide vanes** — Aerodynamically designed, precision cast, adjustable inlet guide vanes, connected by aircraft-style linkages and controlled by a precise electric actuator, maintain chilled water temperature within .5 F (.3 C) of desired set point.

**Variable diffuser option** — The M style compressor design incorporates a hydraulically actuated adjustable diffuser wall and fixed diffuser vanes to increase stability and efficiency across your entire load spectrum. This unique design is ideally suited to applications where relatively constant entering condenser water temperature is maintained at both full and part load. The adjustable diffuser wall is precisely positioned by the microprocessor in response to both compressor load and lift. The precise positioning of the diffuser wall avoids compressor surge and maintains optimum chiller efficiency over a wide range of operating conditions.

**Serviceable compressor** — Simple V-band type vertical compressor casing connectors allow quick access to all compressor parts when servicing or inspection is required. Inspection covers on the transmission casing permit gear and bearing inspection without costly teardowns.

**Compressor run tests** — Every compressor assembly is run tested prior to assembly to the chiller to ensure proper lubrication, low vibration, and smooth guide vane travel in accordance with stringent Carrier engineering requirements.

**Heat exchanger design ensures reliable operation.**

**Double-grooved tubesheet holes** — All tubing is rolled into double-grooved tubesheet holes to prevent costly water leaks into the refrigeration system.

**Pressure tests** — Each heat exchanger is hydrostatically tested at 150% design operating water pressure and air tested on the refrigerant side to detect and correct any leaks prior to shipment.

**Refrigerant distribution system** — The cooler refrigerant distribution system evenly distributes liquid along the entire length of the vessel to assure all heat exchange surfaces are equally submerged in liquid refrigerant.

**Condenser impingement baffle** — A condenser entrance baffle prevents direct impingement of high velocity compressor discharge gas onto the condenser tubing, eliminating tube vibration and wear. The Carrier baffle is designed specifically to provide low flow losses and increase overall operating efficiency.

**Liquid metering device** — Carrier's simplified liquid metering design precisely meters refrigerant flow from the condenser to the cooler ensuring the proper amount of refrigerant is supplied to the cooler under all operating conditions.

**Thermal purge system** — The corrosion resistant stainless steel thermal purge utilizes a Carrier patented design to remove water and noncondensables directly from the center of the condenser bundle, preventing blanketing of the heat exchange surface for predictable and efficient operation.

**Intelligent microprocessor controls increase reliability and facilitate maintenance.**

**Self-diagnostic controls** — Self-diagnostic intelligent controls instantaneously identify the cause of all safety shutdowns and retain the cause in memory for later recall, reducing maintenance time and cost.

**Ramp loading** — User programmable ramp loading at start-up prevents rapid opening of inlet guide vanes, permits a smooth, gradual pull-down of loop water temperature and eliminates overshoot of desired chilled water set point. As a result, there is less likelihood of exceeding utility demand limits and incurring demand charges during start-up.

**Prestart and post shutdown protection** — The microprocessor automatically scans all chiller sensors prior to start-up and provides pre- and post-start compressor lubrication ensuring all components are properly lubricated and protected from misuse.

**Motor and starter protection** — Motor and starter protection is provided with continuous monitoring of motor current, motor winding temperature, voltage fluctuations, starter transition time, motor acceleration time, starting intervals, and number of starts.

**Nuisance shutdowns avoided** — Automatic capacity override feature unloads the compressor whenever 3 key safety limits are approached, thereby eliminating nuisance shutdowns whenever possible.

**Pump and tower fan control** — Control of system chilled water pump, condenser water pump, and cooling tower fans from the chiller microprocessor reduces installation cost and ensures correct sequence of operation.

**Automatic recycle control** — The microprocessor continuously monitors chiller load and actual supply chilled water temperature. When the supply chilled water temperature exceeds the set point and low chiller capacity is sensed, the chiller automatically shuts down and enters a recycle mode. Tower fans and condenser pumps are de-activated while the chilled water pump continues operation. The microprocessor monitors the supply water temperature and automatically reenergizes the chiller when the temperature drifts above the desired set point.

**Troubleshooting ease** — A comprehensive controls test, activated from the chiller control panel, allows the operator to manually check all safeties and to energize water pumps, tower fans, oil pump, and purge pump for quick identification of faulty components.

### Optimum operating efficiency

**Precisely machined impellers** — Precision cast aluminum impellers are machined on computer controlled machining centers for a perfect match of blade contour and impeller diameter to your specified operating conditions, resulting in optimum compressor efficiency under all loads.

**Refrigerant-cooled hermetic motors** — High efficiency hermetic motors provide optimum full-load and increased part-load efficiency as a result of the cooler winding operating temperatures inherent in the Carrier hermetic motor design.

**Integral thermal economizer** — Improved refrigerant cycle efficiency is obtained through the patented Carrier integral thermal economizer. Condensed saturated liquid is metered through precisely sized orifices to the economizer chamber where a portion of the liquid flashes to vapor and is recondensed to a lower saturated temperature and pressure by the cold incoming condenser water. The result is an increased refrigeration effect, less compressor work, and reduced chiller power consumption.

**High efficiency tubing** — High efficiency heat exchanger tubing with unique external finning dramatically improves refrigerant side heat transfer efficiency while internal enhancement increases water turbulence. This reduces fouling tendencies and increases overall chiller efficiency.

## Table of contents

	Page
Model Number Nomenclature .....	3
Options and Accessories .....	3
Machine Components .....	4
Physical Data .....	5
Dimensions .....	6
Performance Data .....	7
Electrical Data .....	13
Controls .....	14
Typical Piping and Wiring .....	17
Application Data .....	18
Guide Specifications .....	22



## Model number nomenclature

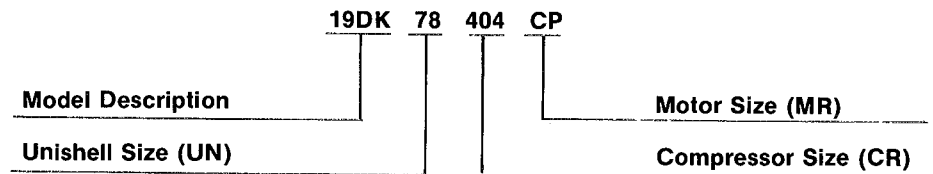

NOTE: All items contained in this model number description are obtainable from a computerized chiller selection for specific operating conditions

## Options and Accessories

ITEM	OPTION*	ACCESSORY†
Marine Water Boxes	X	
Water Nozzles (Victaulic Grooves or Flanges)	X	
Factory-Insulated Cooler, Suction Elbow, Cooler Tubesheets	X	
Hot Gas Bypass	X	
Expanded Services Panel	X	
Data Logging System		X
Soleplates		X

\*Factory installed  
†Field installed

# Machine components

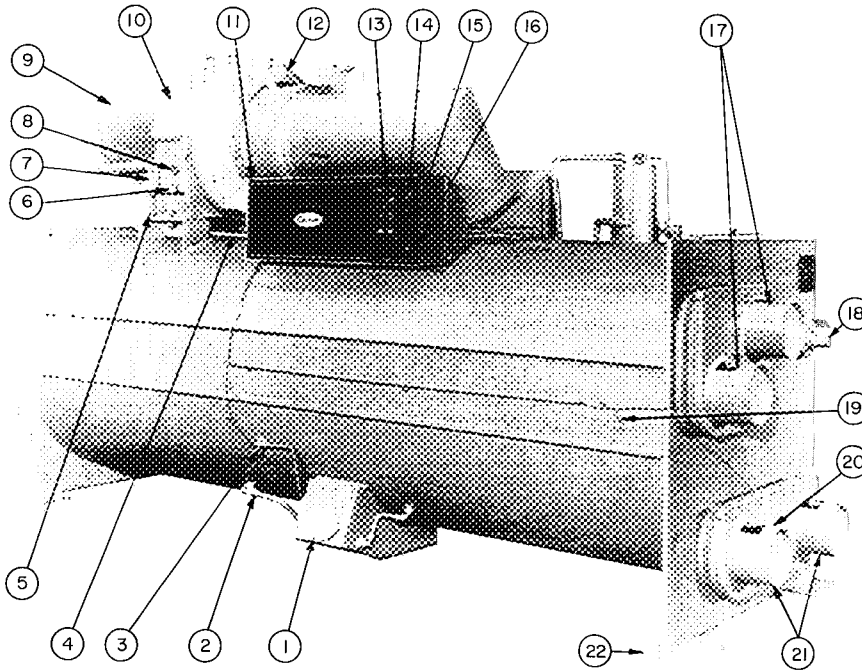

- 1 — Flow Valve Chamber
  - 2 — Cooler Charging Valve
  - 3 — Cooler Refrigerant Temperature Sensor
  - 4 — Field Wiring Knockouts
  - 5 — Oil Heater and Thermostat Terminal Box
  - 6 — Oil Reservoir Temperature Gage
  - 7 — Oil Level Sight Glass
  - 8 — Return-Oil Temperature Gage
  - 9 — Compressor Nameplate (Hidden)
  - 10 — Compressor Access Plate
  - 11 — Diffuser Feedback Potentiometer (Hidden)\*
  - 12 — Diffuser Actuator (Hidden)\*
  - 13 — Microprocessor Control Panel
  - 14 — Condenser Pressure Gage
  - 15 — Cooler Pressure Gage
  - 16 — Oil Pump Differential Pressure Gage
  - 17 — Condenser Water Nozzles
  - 18 — Safety Relief Device (Rapture Disc)
  - 19 — Condenser Refrigerant Temperature Sensor
  - 20 — Chilled Water Temperature Sensor (Hidden)
  - 21 — Cooler Water Nozzles
  - 22 — Support Plates
- \*Available on DM compressors only

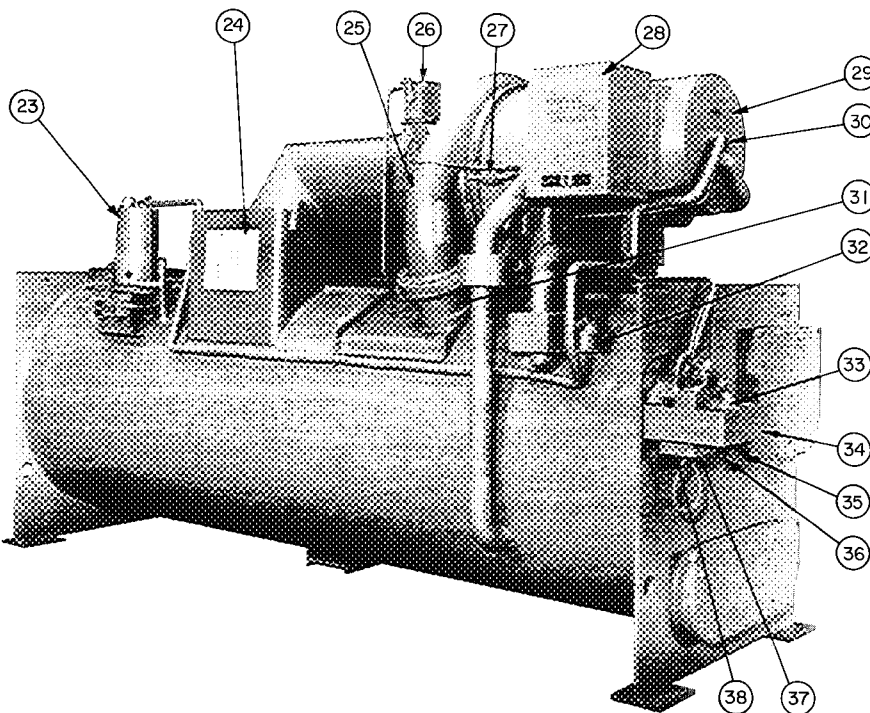

- 23 — Purge Assembly
- 24 — Machine Informative Plate Location
- 25 — Vane Seal Oil Cap (Hidden)
- 26 — Guide Vane Actuator
- 27 — Inlet Volute Drain Strainer
- 28 — Compressor Terminal Box
- 29 — Motor End Cover
- 30 — Motor Rotation Sight Glass
- 31 — Discharge Temperature Sensor (Hidden)
- 32 — Refrigerant Filter
- 33 — Oil Cooler Solenoid Valve and Plug Valve
- 34 — Oil Pump, Cooler and Filter Assembly
- 35 — Oil Charging Valve
- 36 — Oil Cooler Drain Plug
- 37 — Oil Pump Starter, Factory Installed
- 38 — Oil Pressure Regulating Valve (Factory Set)

# Physical data

## COMPRESSOR WEIGHTS\*

MODEL	COMPRESSOR SIZE	ASSEMBLY (Less Motor)	
		lb	kg
19DK	172-258	1750	794
	282-408	2510	1139
19DM	204-286	2585	1173
	314-506	3665	1662

\*Net weights may vary from those listed by  $\pm 5\%$  depending upon casting process. For total compressor weight, add applicable motor weight (see Motor Weight table)

## MOTOR COMPRESSOR COMBINATIONS

MODEL	MOTOR SIZE	USED WITH COMPRESSOR
19DK	AA through AD	112 through 168
	AE	112 through 258
	CA through CL*	172 through 258
	CD through CQ	282 through 408
19DM	AE through CL*	240 through 286
	CD through CQ	314 through 506

\*CA available in high-voltage only; CL not available in 50 Hz with compressors 172-258

## MOTOR WEIGHTS\*

MOTOR SIZE	TOTAL WEIGHT		ROTOR WEIGHT		MOTOR END BELL	
	lb	kg	lb	kg	lb	kg
AA	520	236	110	50		
AB	530	240	115	52	70	32
AC	540	245	120	54		
AD	580	263	130	59	70	32
AE	610	277	140	64	70	32
CA	920	417	170	77	90	41
CB	940	426	170	77		
CC	980	445	180	82	90	41
CD	1020	463	190	86		
CE	1060	481	200	91		
CL	1100	499	210	95	90	41
CM	1130	513	220	100		
CN	1190	540	230	104		
CP	1210	549	230	104	90	41
CQ	1240	562	240	109		

\*Listed weights are for low-voltage (200 through 600-v) motors. To calculate the weight of high-voltage motors, add 200 lb (91 kg) to size CA through CD total weight, and add 150 lb (68 kg) to size CE through CQ total weight

## 19DK MACHINE AND HEAT EXCHANGER WEIGHTS

UNISHELL SIZE	MACHINE TOTAL WEIGHT				MACHINE CHARGE				HEAT EXCHANGER WEIGHT		WATER BOX COVER			
	Operating		Rigging		Refrigerant*		Water				Cooler		Condenser	
	lb	kg	lb	kg	lb	kg	lb	kg	lb	kg	lb	kg		
42	9,136	4,144	8,276	3,754	500	227	360	163	6,126	2,779				
44	9,281	4,210	8,376	3,799	525	238	380	172	6,206	2,815	53	24	76	34
46	9,446	4,285	8,476	3,845	550	249	420	191	6,326	2,869				
50	10,961	4,972	9,856	4,471	575	261	530	240	6,556	2,974				
51	11,191	5,076	10,056	4,561	575	261	560	254	6,756	3,064				
53	11,456	5,196	10,256	4,652	600	272	600	272	6,956	3,155	73	33	76	34
55	11,716	5,314	10,456	4,743	625	283	635	288	7,156	3,246				
57	11,971	5,430	10,656	4,833	625	283	690	313	7,356	3,337				
61	15,412	6,990	13,652	6,192	775	352	985	447	9,352	4,242				
63	15,792	7,163	13,952	6,328	810	367	1,030	467	9,602	4,355	123	56	137	62
65	16,122	7,312	14,152	6,419	850	386	1,120	508	9,852	4,468				
71	17,693	8,025	15,578	7,066	975	442	1,140	517	11,278	5,115	138	63	137	62
72	17,953	8,143	15,778	7,157	985	447	1,190	540	11,478	5,206	138	63	137	62
73	18,338	8,318	16,078	7,293	1,010	458	1,250	567	11,678	5,297	138	63	137	62
76	19,078	8,653	16,578	7,519	1,100	499	1,400	635	12,348	5,601	208	94	268	122
77	19,648	8,912	17,978	7,701	1,150	522	1,520	689	12,698	5,760	208	94	268	122
78	20,108	9,121	17,278	7,837	1,200	544	1,630	739	13,058	5,923	208	94	268	122

\*Refrigerant Charge — The refrigerant weight listed is the charge required for optimum machine performance at nominal conditions of 44 F (7 C) leaving chilled water, 95 F (35 C) leaving condenser water and maximum machine tons. The amount of refrigerant shipped with the machine exceeds the amount required at these conditions. Therefore, do not charge the full quantity without observing machine performance to determine the exact amount needed.

## 19DM MACHINE AND HEAT EXCHANGER WEIGHTS

UNISHELL SIZE	MACHINE TOTAL WEIGHT				MACHINE CHARGE				HEAT EXCHANGER WEIGHT		WATER BOX COVER			
	Operating		Rigging		Refrigerant*		Water				Cooler		Condenser	
	lb	kg	lb	kg	lb	kg	lb	kg	lb	kg	lb	kg		
50	12,216	5,541	11,111	5,040	575	261	530	240	6,556	2,974				
51	12,446	5,646	11,311	5,131	575	261	560	254	6,756	3,064				
53	12,711	5,766	11,511	5,221	600	272	600	272	6,956	3,155	73	33	76	34
55	12,971	5,884	11,711	5,312	625	283	635	288	7,156	3,246				
57	13,226	5,999	11,911	5,403	625	283	690	313	7,356	3,337				
61	16,900	7,666	15,140	6,868	775	352	985	447	9,352	4,242				
63	17,280	7,838	15,440	7,004	810	367	1,030	467	9,602	4,355	123	56	137	62
65	17,610	7,988	15,640	7,094	850	386	1,120	508	9,852	4,468				
71	19,219	8,718	17,104	7,758	975	442	1,140	517	11,278	5,115	138	63	137	62
72	19,479	8,836	17,304	7,849	985	447	1,190	540	11,478	5,206	138	63	137	62
73	19,864	9,010	17,604	7,985	1,010	458	1,250	567	11,678	5,297	138	63	137	62
76	20,604	9,346	18,104	8,212	1,100	499	1,400	635	12,348	5,601	208	94	268	122
77	21,174	9,605	18,504	8,393	1,150	522	1,520	689	12,698	5,760	208	94	268	122
78	21,634	9,813	18,804	8,529	1,200	544	1,630	739	13,058	5,923	208	94	268	122

\*Refrigerant Charge — The refrigerant weight listed is the charge required for optimum machine performance at nominal conditions of 44 F (7 C) leaving chilled water, 95 F (35 C) leaving condenser water and maximum machine tons. The amount of refrigerant shipped with the machine exceeds the amount required at these conditions. Therefore, do not charge the full quantity without observing machine performance to determine the exact amount needed.

# Dimensions

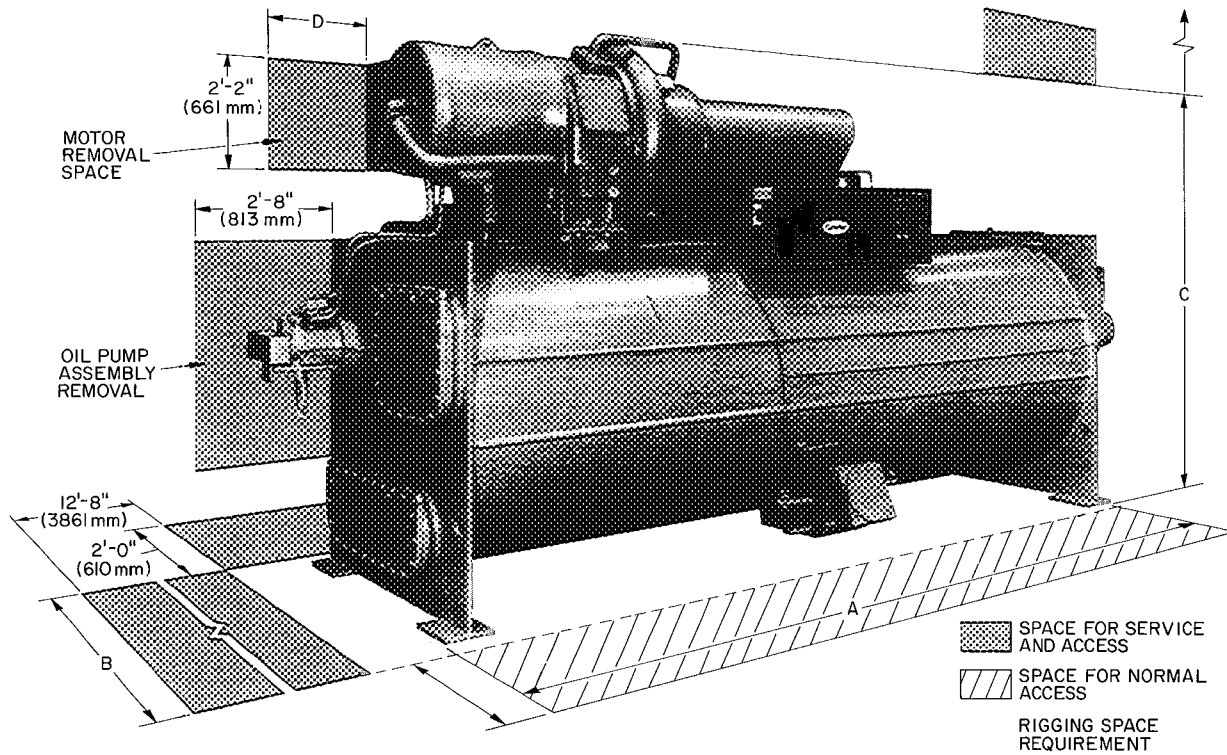

MACHINE MODEL	UNISHELL SIZES	DIMENSIONS						NOZZLE SIZE (in.)							
		Length A		Width B		Height C		Cooler Passes				Condenser Passes			
		ft-in.	mm	ft-in.	mm	ft-in.	mm	1	2	3	4	1	2	3	4
19DK	42, 44, 46	14-4	4369	3-8	1118	6-5	1956	6	4	—	—	8	6	—	—
	50, 51, 53, 55, 57	14-4	4369	3-8	1118	6-11	2108	8	6	6	—	8	6	4	—
19DK/DM	61, 63, 65	14-4	4369	4-6	1372	8-1	2464	8	6	6	6	10	8	6	6
	71, 72, 73	14-4	4369	5-0	1524	8-10	2692	10	8	8	6	10	8	6	6
	76, 77, 78	14-6	4420	5-0	1524	8-10	2692	12	8	8	6	12	10	8	6

\*Length shown is chiller with nozzles on drive end only. For length with nozzles on both ends, add 2 in (51 mm)

## 19DK SERVICE CLEARANCE FOR MOTORS

DESIGN CENTER VOLTAGES	UNISHELL	COMPR	MOTOR	CLEAR-ANCE D	
				ft-in.	mm
200, 230, 346, 380, 400, 460, 575	42 through 65	112 through 168	AA through AE	1-11	585
	50 through 78	172 through 258	AE		
	61 through 78	282 through 408	CB through CL	2-1	635
2400, 3000, 3300, 4160	50 through 78	172 through 258	CA through CL	2-1	635
	61 through 78	282 through 408	CD through CQ		

NOTE: Service access should be provided per ANSI Standard B9.1 NFPA 70 (NEC) and local safety codes. Clear space adequate for inspection, servicing and rigging of all major components of the chiller is required

## 19DM SERVICE CLEARANCE FOR MOTORS

DESIGN CENTER VOLTAGES	UNISHELL	COMPR	MOTOR	CLEAR-ANCE D	
				ft-in.	mm
200, 230, 346, 380, 400, 460, 575	50 through 78	204 through 286	AE	2-8	813
	61 through 78	314 through 506	CB through CL	2-8	813
2400, 3000, 3300, 4160	50 through 78	204 through 286	CA through CL	3-5	1042
	61 through 78	314 through 506	CD through CQ		

NOTE: Service access should be provided per ANSI Standard B9.1 NFPA 70 (NEC) and local safety codes. Clear space adequate for inspection, servicing and rigging of all major components of the chiller is required

# Performance data

## SELECTION EXAMPLES — ENGLISH

NOMINAL TONS	19DK CHILLER MODELS	
	Medium Efficiency (0.66-0.68 kW/Ton)*	High Efficiency (0.62-0.64 kW/Ton)*
150	19DK50123AE	19DK57123AE
200	19DK55173AE	19DK57173CB
250	19DK61203CC	19DK61203CC
300	19DK65254CL	19DK71253CD
350	19DK65284CP†	19DK73313CL
400	19DK71354CN	19DK73353CM
450	19DK73354CP	19DK78353CN
500	19DK78404CQ	—

NOMINAL TONS	19DM CHILLER MODELS	
	Medium Efficiency (0.64-0.66 kW/Ton)*	High Efficiency (0.60-0.62 kW/Ton)*
150	—	—
200	19DM53205AE	19DM61204AE
250	19DM57255CC†	19DM61254CC
300	19DM61286CE	19DM71285CD
350	19DM65355CL†	19DM71354CL
400	19DM71455CN†	19DM73454CM
450	19DM73505CP†	19DM77454CN
500	—	19DM78505CQ

### LEGEND

**kW** — Compressor motor power input (kilowatts)

\*In some instances, the chiller model listed will have an input power consumption per net cooling load that is less than the range indicated

†High Performance (HPT) tubing is used in the condenser

#### NOTES:

- Motors are 460-3-60
- All heat exchangers are 2-pass and the standard field fouling allowance is employed
- Maximum pressure drop is 33 ft wg
- All units, unless otherwise indicated, have Ultrachill (ULTC) tubing in the cooler and turbochill5 (TCT5) tubing in the condenser
- Above table is based on the following water conditions:  
Cooler: 54 – 44 F  
Condenser: 85 F entering water, 3 gpm/ton
- Contact the local Carrier sales office to obtain a computerized selection for other voltages, chiller configurations, or water conditions

## SELECTION EXAMPLES — SI METRIC

NOMINAL USRT	kW	19DK CHILLER MODELS	
		Medium Efficiency (0.66-0.68 kW/USRT)*	High Efficiency (0.62-0.64 kW/USRT)*
150	530	19DK50123AD	19DK57113AE
200	700	19DK55173AE	19DK57173CB
250	880	19DK57203CD	19DK57203CD
300	1060	19DK71253CD	19DK71253CD
350	1230	19DK71314CN†	19DK73313CL
400	1410	19DK71314CP†	19DK73313CM
450	1580	19DK73354CP	19DK77353CN
500	1760	19DK78404CQ	—

NOMINAL USRT	kW	19DM CHILLER MODELS	
		Medium Efficiency (0.64-0.66 kW/USRT)*	High Efficiency (0.60-0.62 kW/USRT)*
150	530	—	—
200	700	19DM61254AE†	19DM61254CB
250	880	19DM63286CC†	19DM71285CC
300	1060	19DM65355CD†	19DM71354CD
350	1230	19DM65355CM†	19DM71354CL
400	1410	19DM65455CN†	19DM73454CM
450	1580	19DM73505CP†	19DM76454CN
500	1760	19DM77505CQ†	19DM78505CP

### LEGEND

**kW** — Compressor motor power input (kilowatts)

**kW** — Capacity (kilowatts)

**USRT** — United States rated tons

\*In some instances, the chiller model listed will have an input power consumption per net cooling load that is less than the range indicated

†HPT tubing is used in the condenser

#### NOTES:

- Motors are 380-3-50
- All heat exchangers are 2-pass and the standard field fouling allowance is employed
- Maximum pressure drop is 93 kPa wg.
- All units, unless otherwise indicated, have ULTC tubing in the cooler and TCT5 tubing in the condenser
- Above table is based on the following water conditions:  
Cooler: 12.5 – 7 C  
Condenser: 29.5 C entering water, 189 l/s/USRT
- Contact the local Carrier sales office to obtain a computerized selection for other voltages, chiller configurations, or water conditions

# Performance data (cont)

## AUXILIARY RATINGS — 3 PHASE, 50/60 HZ

ITEM	AVERAGE KW	DESIGN CENTER VOLTAGE	SUPPLY V-PH-HZ	SEALED KVA	INRUSH KVA
Oil Pump	0.37	230	220/240-3-50	0.81	5.22
		410	380/440-3-50		
Oil Pump	0.37	220	200/240-3-60	0.81	5.22
		460	440/480-3-60		
		575	550/600-3-60		

KVA — Kilo volt-amperes

### NOTES:

- 1 Average power consumed by auxiliaries is included in the values shown in the Selection Example tables.
- 2 Control circuit ratings provide for 3200MP controls, ESPII options, compressor vane operators, purge unit, two 1CR relays (15-VA each), and one K2, PR-1, PR-2, and PR-3 relays. The purge operates only when non-condensables are present. A 15 amp lighting circuit can be used instead of a transformer.
- 3 Oil heater must be on a circuit that can provide continuous service when the compressor starter is disconnected. During compressor shutdown, the thermostatic control allows the heater to operate only when required.

## AUXILIARY RATINGS — 115 VOLT, 1 PHASE, 50/60 HZ

ITEM	INRUSH KVA	SEALED KVA	AVERAGE KW
Controls	0.30	0.23	0.05
Oil Heater	—	1.00	1.00

## TYPICAL PART-LOAD PERFORMANCE CURVE

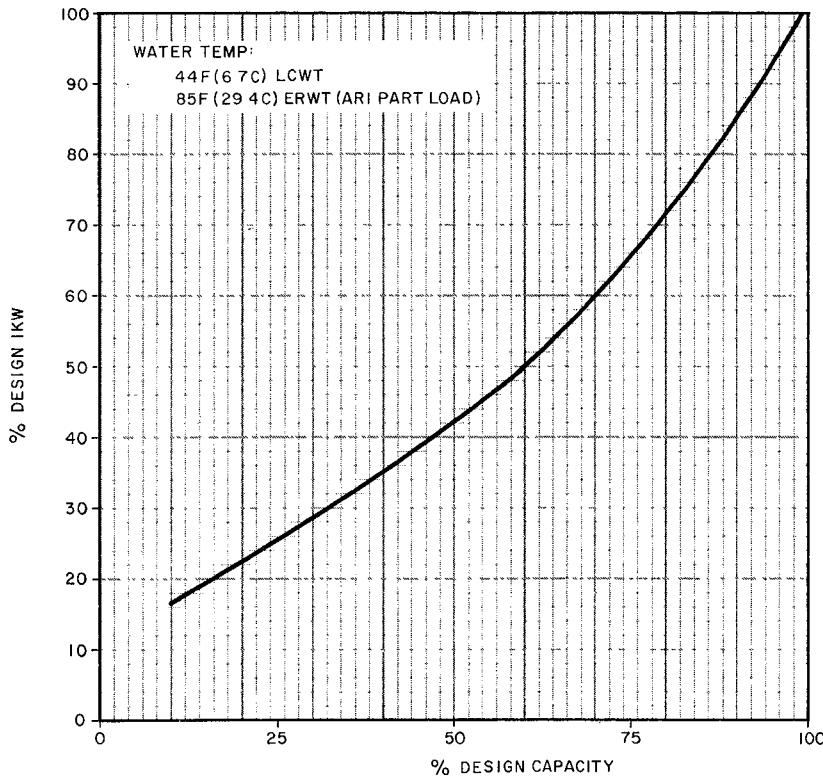

LCWT — Leaving Chilled Water Temperature  
ERWT — Entering Condenser Water Temperature

NOTE: Curve represents the specific part-load performance of the 19DK73353CM, a 400 ton, high efficiency unit specified on the Selection Examples — English tables. The curve also represents typical part-load performance. It is not meant to imply that all applications follow this exact curve. Part-load performance for specific application conditions may be determined from a computerized selection.

## Integrated part-load performance

The Integrated Part-Load Value (IPLV) is the weighted average of chiller input power consumption per evaporator load over the complete part-load range of chiller operation. The IPLV was established by ARI and is included in the latest version of ARI 550 Standards. Calculate IPLV as follows:

$$IPLV = 0.1 \left( \frac{A+B}{2} \right) + 0.5 \left( \frac{B+C}{2} \right) + 0.3 \left( \frac{C+D}{2} \right) + 0.1 (D)$$

Where:

A = chiller power consumption/evaporator load at 100% load point.

B = chiller power consumption/evaporator load at 75% load point.

C = chiller power consumption/evaporator load at 50% load point.

D = chiller power consumption/evaporator load at 25% load point.

(All water conditions as defined by ARI Standard 550).

To determine specific full-load and part-load machine performance you must obtain a computerized selection from your local Carrier sales office.

### IPLV calculation example

A computerized selection for a 400 ton high-efficiency machine produces the following information:

Model: 19DK73353CM

100% load at 400 tons = .63 kW/ton = A

75% load at 300 tons = .55 kW/ton = B

50% load at 200 tons = .53 kW/ton = C

25% load at 100 tons = .68 kW/ton = D

IPLV

$$= 0.1 \left( \frac{.63 + .55}{2} \right) + .5 \left( \frac{.55 + .53}{2} \right) + 0.3 \left( \frac{.53 + .68}{2} \right) + 0.1 (.68)$$

$$= 0.1 (.59) + 0.5 (.54) + 0.3 (.605) + 0.1 (.68)$$

$$= 0.059 + 0.27 + 0.182 + 0.068$$

$$= 0.579$$

### UNISHELL CONDENSER

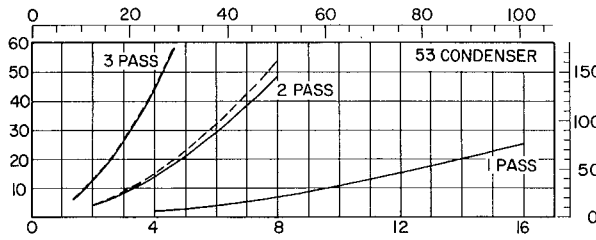
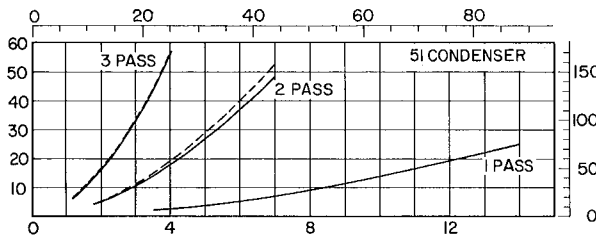
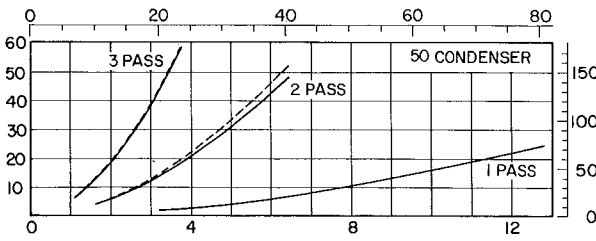
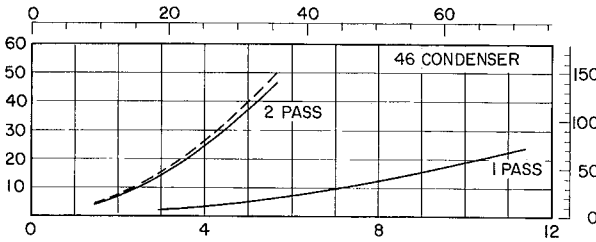
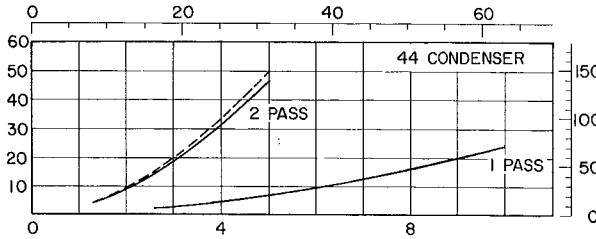
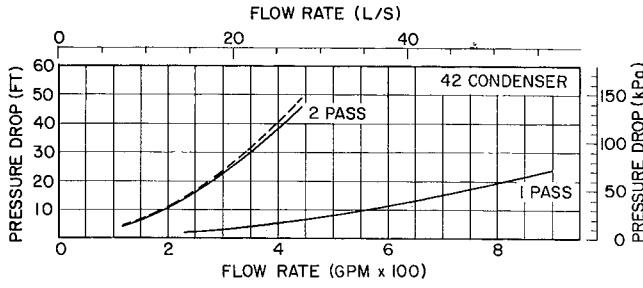

### UNISHELL COOLER

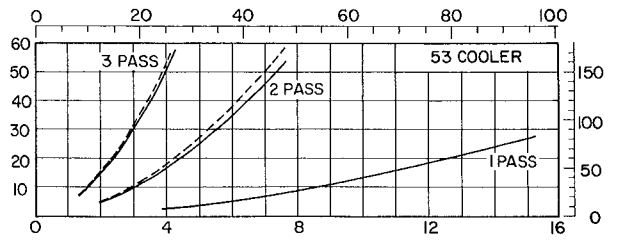
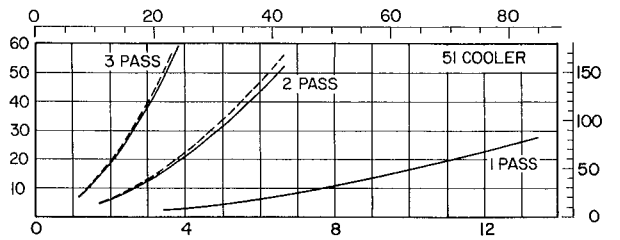
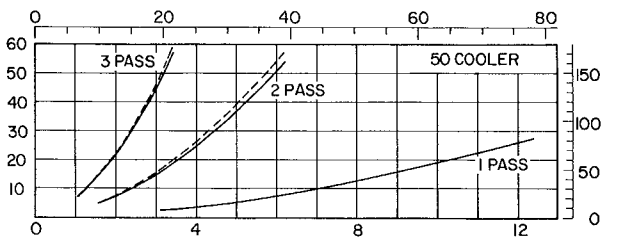
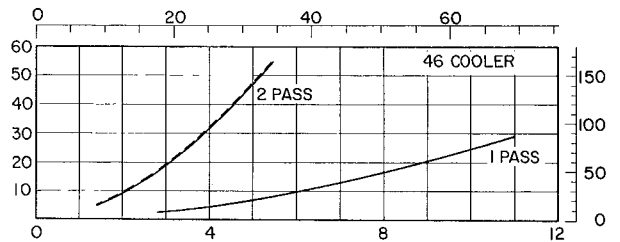
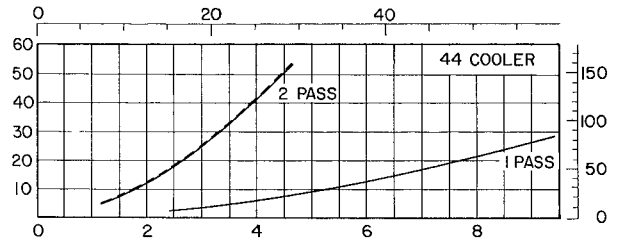
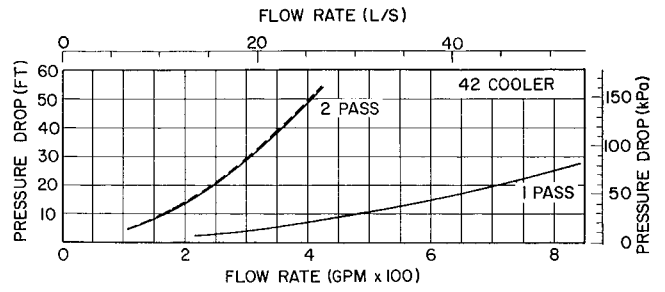

**NOTES:**

- 1 Solid lines show pressure drop with standard water box. Dashed lines show pressure drop with marine water box option
- 2 Cooler pressure drop is based on ULTC tubing. Condenser pressure drop is based on TCT5 tubing
- 3 To determine pressure drops more accurately and to compensate for actual water temperature, use the computerized selection service available through your local Carrier sales office

# Performance data (cont)

## UNISHELL CONDENSER

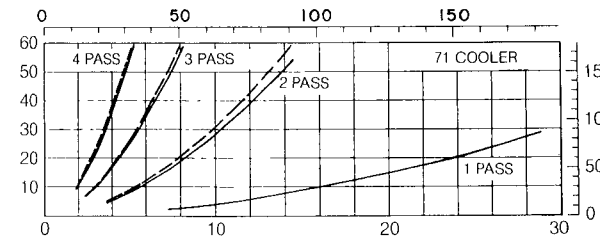
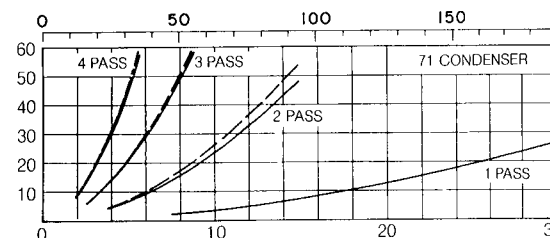
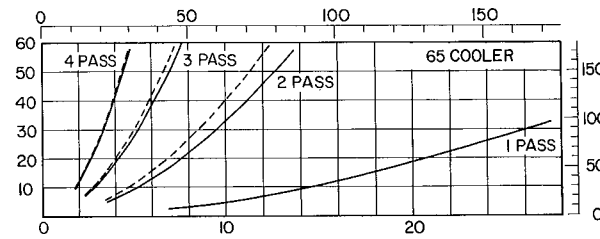
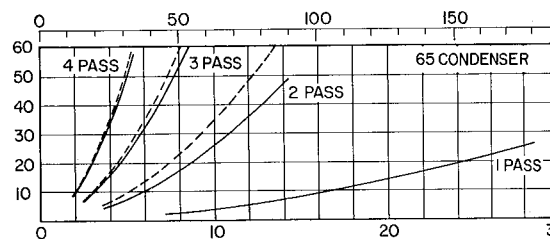
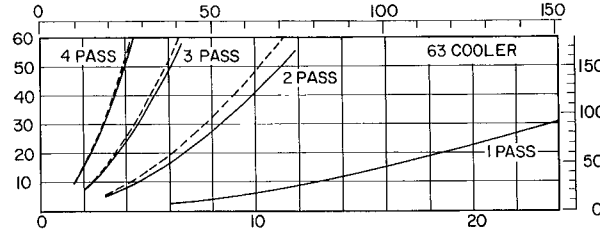
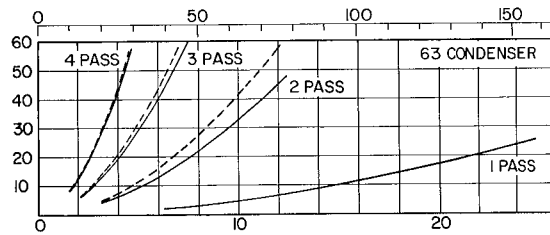
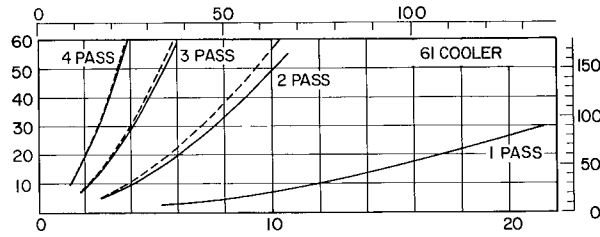
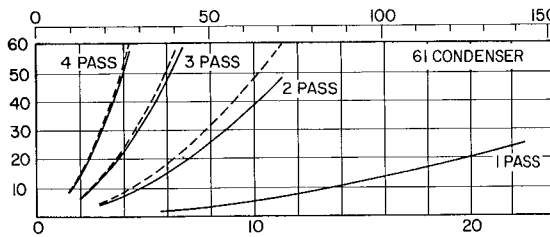
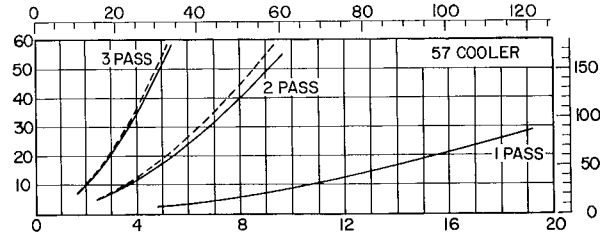
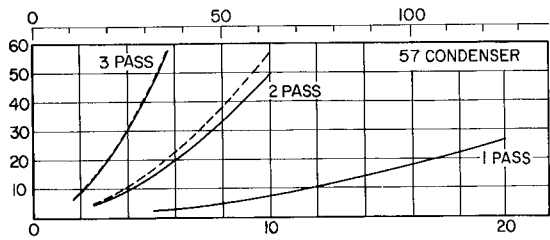
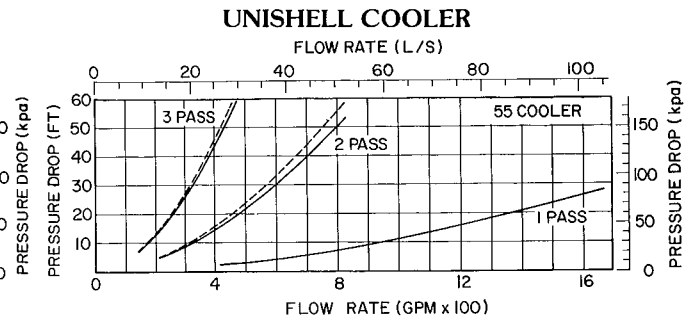
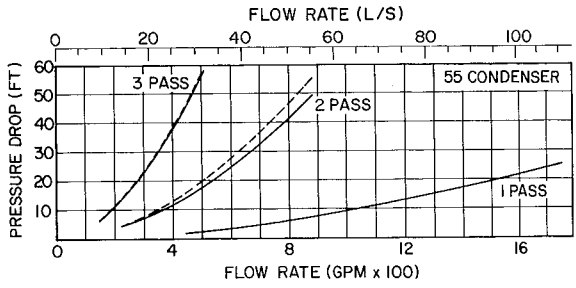

### NOTES

- 1 Solid lines show pressure drop with standard water box. Dashed lines show pressure drop with marine water box option.
- 2 Cooler pressure drop is based on ULTC tubing. Condenser pressure drop is based on TCT5 tubing.
- 3 To determine pressure drops more accurately and to compensate for actual water temperature, use the computerized selection service available through your local Carrier sales office.

## UNISHELL CONDENSER

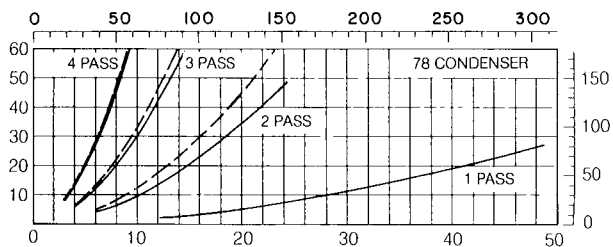
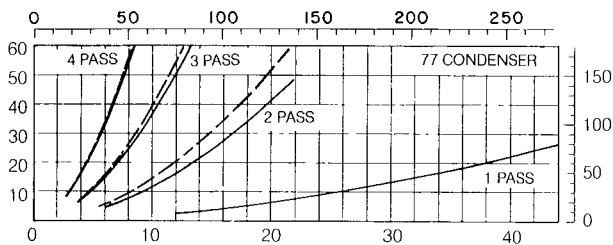
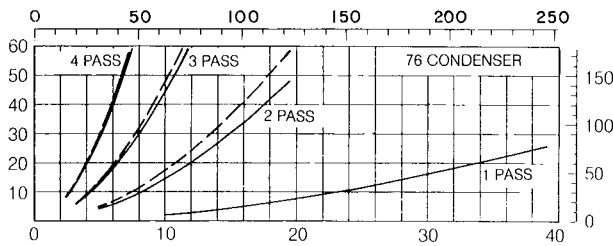
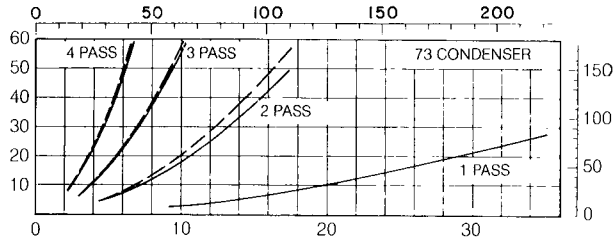
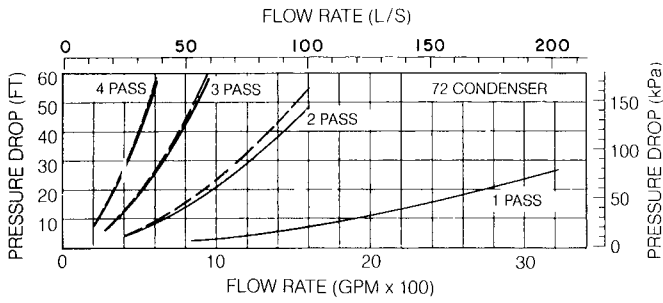

## UNISHELL COOLER

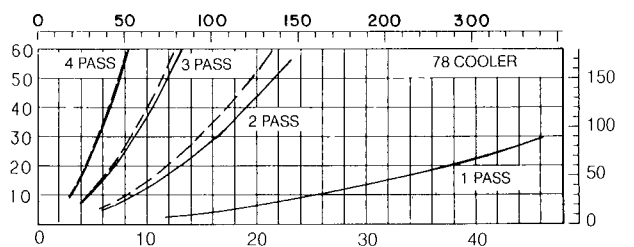
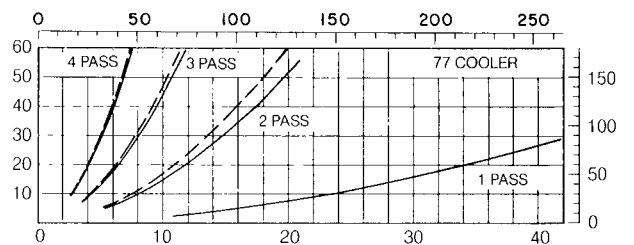
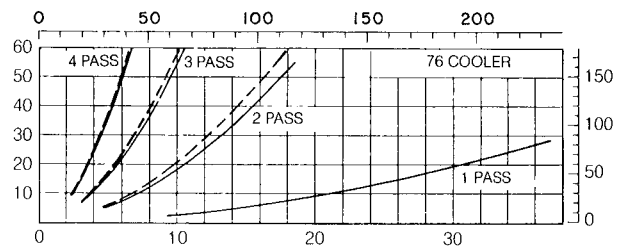
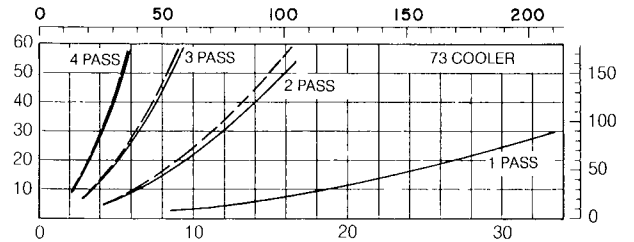
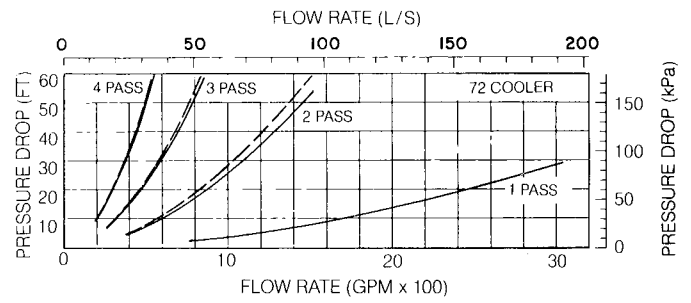

### NOTES:

1. Solid lines show pressure drop with standard water box. Dashed lines show pressure drop with marine water box option.
2. Cooler pressure drop is based on ULTC tubing. Condenser pressure drop is based on TCT5 tubing.
3. To determine pressure drops more accurately and to compensate for actual water temperature, use the computerized selection service available through your local Carrier sales office.

# Performance data (cont)

## TYPICAL MINIMUM ENTERING CONDENSER WATER TEMPERATURE

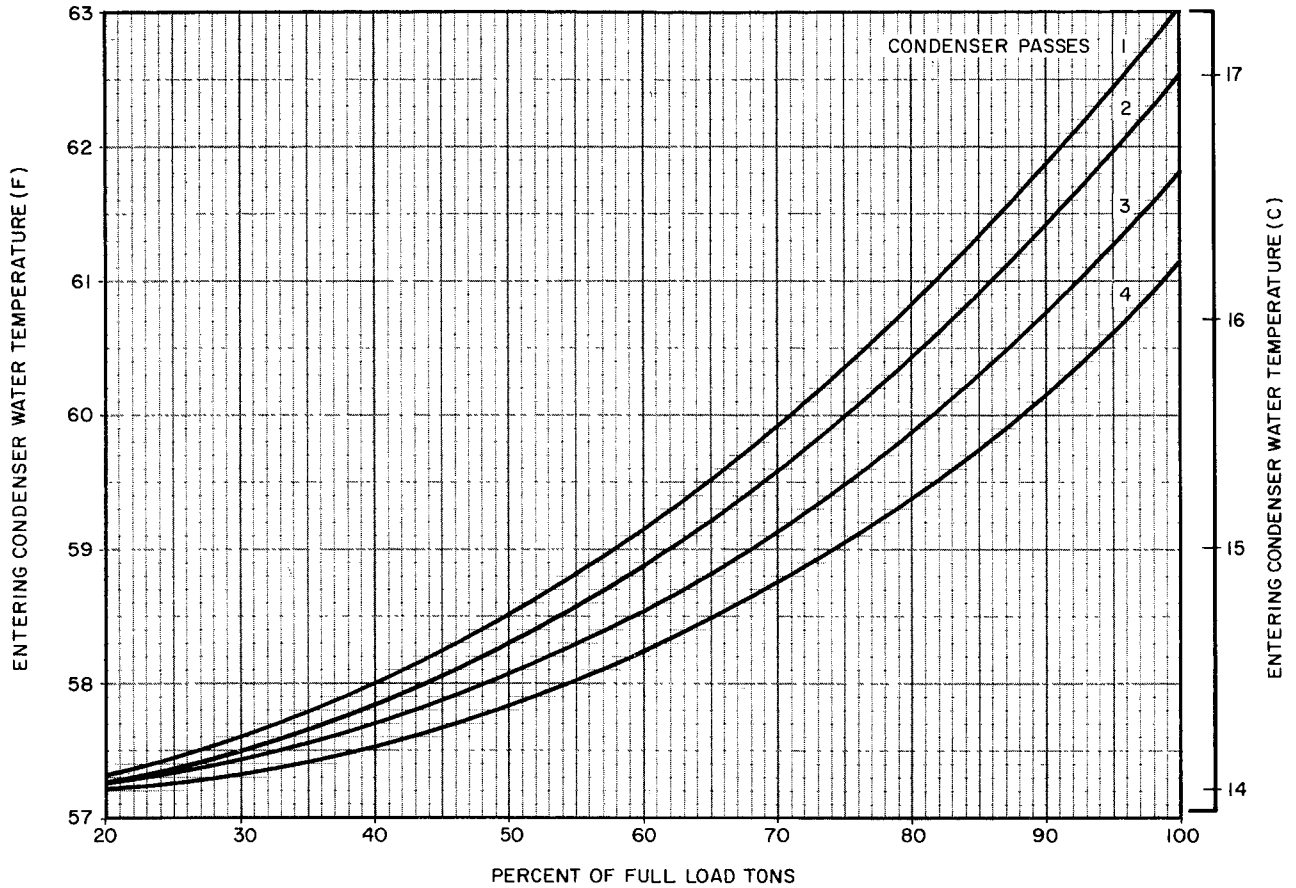

NOTE: Curve is based on water as the cooler fluid. Low temperature brine applications result in a slightly lower minimum entering condenser water temperature curve.

# Controls

## Basic microprocessor controls

**Purpose:** To provide the safety, interlock, capacity control and indications necessary to operate the chiller in a safe and efficient manner.

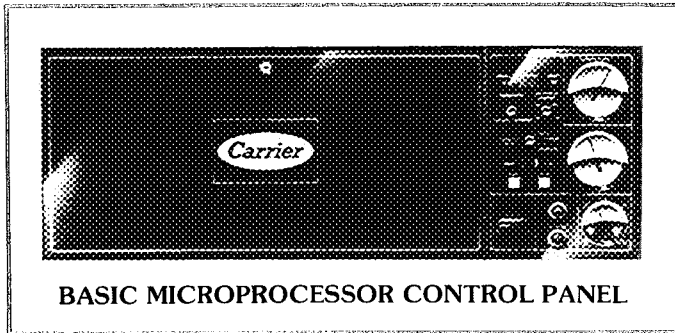

**BASIC MICROPROCESSOR CONTROL PANEL**

## Control system

The microprocessor control on each Carrier centrifugal chiller is factory mounted, wired and tested to assure machine protection and efficient capacity control. In addition, the program logic assures proper starting, stopping and recycling of the machine.

The capacity control system is fully automatic, using the microprocessor for precise control of machine capacity at optimized efficiency for all load conditions.

The operating capacity of each chiller is matched directly with the need for cooling. As cooling needs change, guide vanes in the refrigerant vapor stream entering the compressor change position to maintain the selected chilled water (brine) temperature.

The changes in vane position are initiated by a thermistor located in the leaving chilled water nozzle. This probe constantly relays any variations in water temperature to the microprocessor. The microprocessor causes the guide vane actuator to adjust the guide vane position as required.

If the chilled water temperature drops below the selected design temperature by more than the dead band (adjustable  $\pm 0.5$  to  $\pm 1.0$  degrees F;  $\pm 0.27$  to  $\pm 0.54$  degrees C), the guide vane actuator moves the guide vanes toward a closed position; the rate of refrigerant evaporation slows and chiller capacity decreases. A rise in chilled water temperature above the set point causes the actuator to move the vanes toward a more open position. Refrigerant begins to evaporate at a more rapid rate and chiller capacity increases.

In addition, on 19DM machines, the microprocessor independently senses the load on the compressor (motor amps) and lift on the compressor (cooler temperature and condenser temperature). This information is used to com-

pute the optimum diffuser wall position. The microprocessor then sends a signal to move the variable diffuser wall to this position where the optimum efficiency is obtained for the particular compressor size at the particular set of operating conditions.

Built-in overrides in the capacity control system prevent motor overload. When motor full-load current is reached, the guide vanes stop opening immediately. If motor current continues to increase, the guide vanes begin to close until motor current is reduced.

To minimize at start-up current demand, the soft loading feature is employed. This feature loads the machine/motor in a pre-programmed, gradual manner. This prevents any costly power demand spikes which might otherwise occur during initial loop pull down.

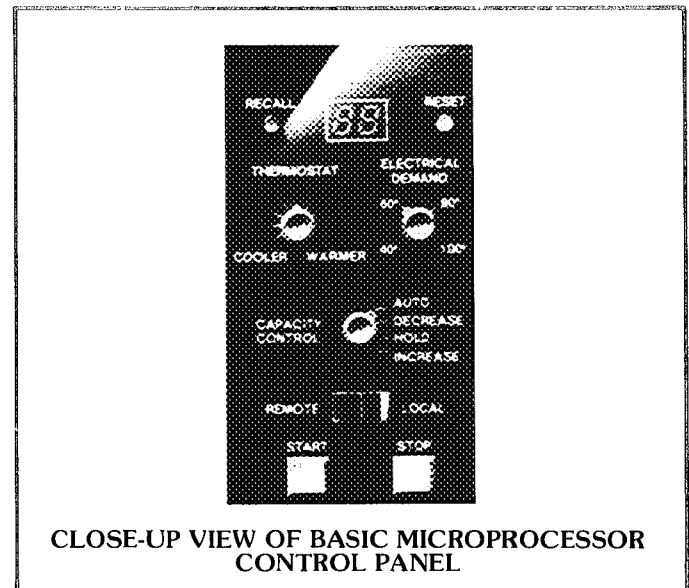

**CLOSE-UP VIEW OF BASIC MICROPROCESSOR CONTROL PANEL**

## Equipment self-diagnostic check

It is recommended that, at initial start-up, the chiller self-diagnostic check be executed. The control panel must be placed in local mode. The moment power is applied to the control it is in an initialization mode for the first 2 minutes. Any time during this initial 2-minute period, or within 2 minutes after a power-on-reset (POR), the RESET button (located on the face of the panel) may be depressed. This action puts the equipment into the self-diagnostic check, which consists of 34 tests. (Details of this test are available in the product Application Data, available from your Carrier salesperson.)

After the tests have been completed, depress the POR button again and the machine is now ready to start.

## Features

### Safety cutouts:

Bearing High Temperature  
Motor High Temperature\*  
Refrigerant (Condenser) High Pressure  
Refrigerant (Cooler) Low Temperature\*  
Lube Oil Low Pressure  
Compressor (Refrigerant) Discharge Temperature  
Under Voltage  
Over Voltage  
Oil Pump Motor Overload  
Cooler and Condenser Water Flow†  
Motor Overload\*  
Motor Acceleration Time  
Intermittent Power Loss  
Welded Compressor Starter

### Capacity control:

Leaving Chilled Water Control  
Soft Loading Control  
Guide Vane Actuator Module  
Diffuser Wall Actuator Module (19DM only)  
Manual — Power (Demand) Limiter  
Manual — Chilled Water Reset

### Interlocks:

Manual/Automatic Remote Start

### Starting/Stopping Sequence

- Pre-Lube/Post-Lube
- Pre-Flow/Post-Flow
- Compressor Starter Interlock
- Oil Cooler Water Flow Solenoid

Pre-Start Check of Sensors Status  
Low Chilled Water (Load) Recycle  
Monitor-Number Compressor Starts  
Manual Reset of Safeties  
Purge Malfunction Override

### Indication:

Chiller Operating Status  
Power-on  
Pre-Start Diagnostic Check  
Compressor Motor Amps  
Pre-Alarm\*‡  
Alarm  
Contact for Remote Alarm  
Safety Shutdown Code  
Elapsed Time (Hours of Operation)

\*Override protection: Causes compressor to first unload automatically and then, if necessary, shutdown

†Required: Field or factory supplied (installed at jobsite)

‡By display code only

## ESP — Expanded Services Panel

Purpose: To enhance the operation capabilities of the chiller and satisfy various customer control requirements.

The ESP can be mounted in the machine control panel, or remotely, as the owner prefers.

It provides:

### Remote indication:

- Chiller operating status
- Shutdown codes
- Key operating parameters
- Self-diagnostics

### Keypad programming capabilities of:

Leaving chilled water temperature

Reset of chilled water temperature from:

- Return chilled water temperature (maintains constant return chilled water temperature)
- EMS, building management system; (4-20 mA) or (1-5 Vdc)
- Remote temperature (i.e., outside air, supply air)
- Load on chiller

Power demand limit

Reset of power demand limit from:

- Stepped-position contact closure (80/60/40% selectable)
- EMS, building management system; (4-20 mA) or (1-5 Vdc)

Two chiller lead-lag operation and control (remote ESP required)

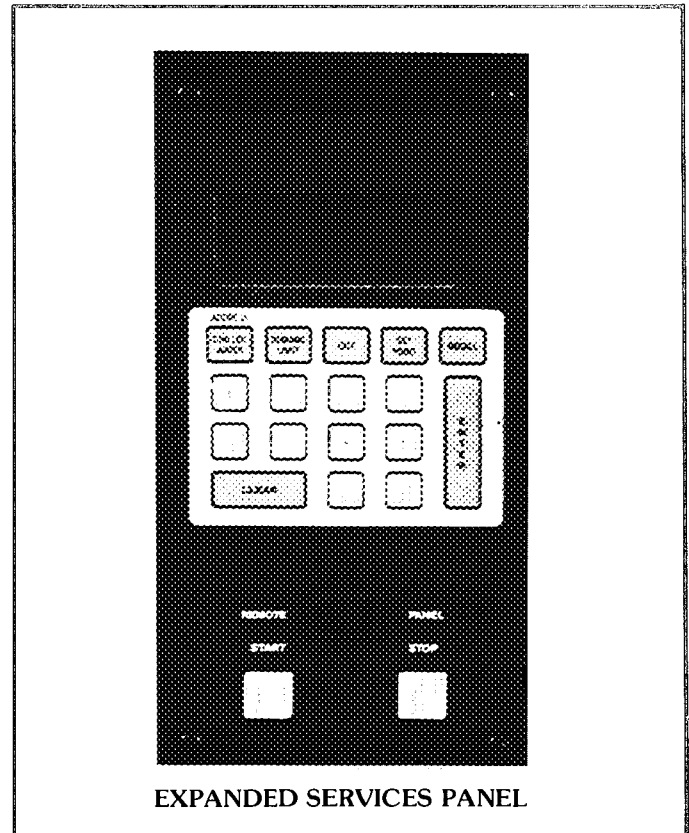

EXPANDED SERVICES PANEL

# Controls (cont)

## Control sequence

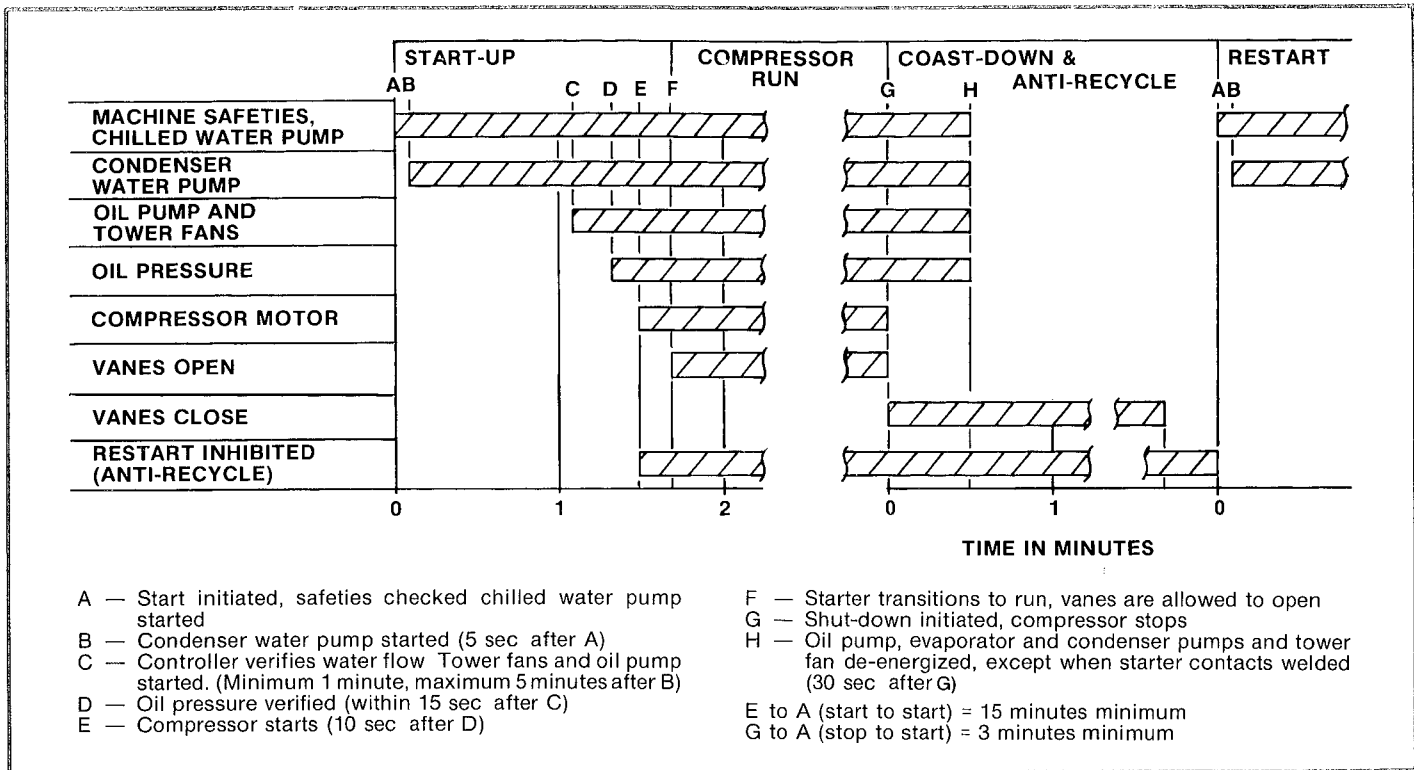

**To start:** Push Start Button — Start initiated; all safeties are checked to see that they are satisfied (if one is not, an indication of the fault will be displayed and the start aborted). The signal is sent to start chilled water pump.

After 5 seconds, the signal is sent to start the condenser water pump and the tower fans.

The microprocessor then puts the start on hold. It checks that water flows reestablished. If satisfied, it will send the signal to start the oil pump and the tower fans. If not satisfied, it will continue to monitor water flows for a maximum of 5 minutes. If water flows are established within the 5 minutes, the microprocessor will send the signal to start the oil pump; if not it will abort the start and give an indication of the reason.

Ten seconds after oil pressure is satisfied, the microprocessor sends a signal to the starter to start the compressor motor. If oil pressure is not satisfied, it will again abort the start and give an indication of the reason

**Once started** the microprocessor initializes the primary restart protection (15 minutes — start to start). It monitors the motor acceleration time and if it is excessive, aborts the start. If the starter fails to transition to run, the start is aborted. Once the starter transitions, the vanes open in a soft loading mode and are then transferred to the capacity control mode.

**To stop:** Push Stop Button — Signal sent to de-energize compressor motor.

The microprocessor ensures that the power to the compressor motor is off, and after 30 seconds sends signal to de-energize the oil pump, the chilled water and condenser water pumps and the tower fan. (If an abnormality keeps the compressor motor energized, the microprocessor will also attempt to keep all 3 pumps energized.

The microprocessor then initializes the secondary restart protection (3 minutes — stop to start), logs the reason for the stop into memory (if it was a safety shutdown) and recycles itself to be ready for the next start.

# Typical piping and wiring

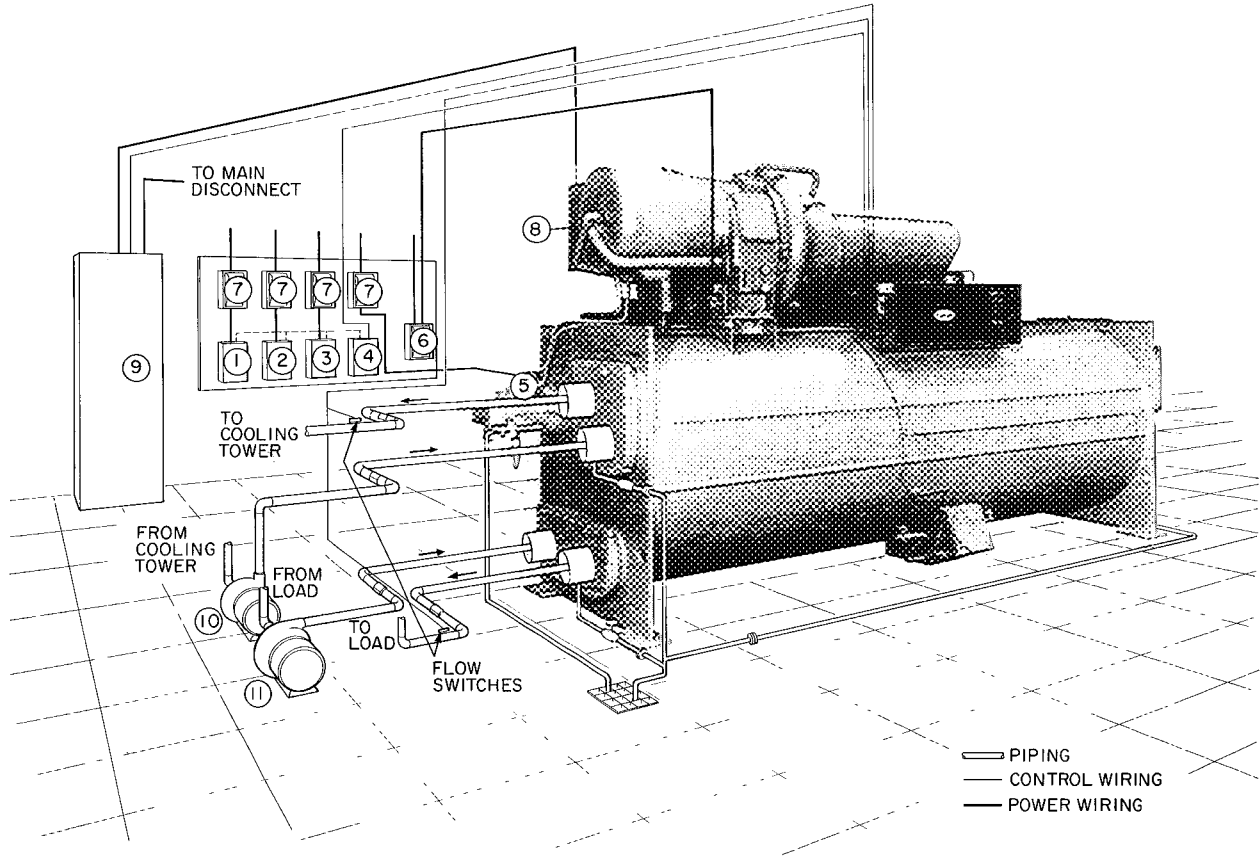

- 1 — Cooling Tower Fan Starter
- 2 — Condenser Water Pump Starter
- 3 — Cooler Water Pump Starter
- 4 — Pilot Relay(s) (Note 6)
- 5 — Oil Pump Starter
- 6 — Fused Disconnect for Oil Heater and Thermostat
- 7 — Fused Disconnect
- 8 — Compressor Motor Terminal Box
- 9 — Compressor Motor Starter
- 10 — Cooler Water Pump
- 11 — Condenser Water Pump

## NOTES

- 1 Wiring and piping shown are for general point-of-connection only and are not intended to show details for a specific installation. Certified field wiring and dimensional diagrams are available on request.
- 2 All wiring must comply with applicable codes.
- 3 Refer to Carrier System Design Manual for details regarding piping techniques.
- 4 A separate 115-volt fused power source for controls is required unless compressor motor controller is furnished with a transformer.
- 5 Oil heater must be on a circuit that can provide continuous service when the compressor starter is disconnected.
- 6 Pilot relays are optional (depending on contactor rating) and may be installed in the main starter enclosure or externally.

# Application data

## Range of application

The 19DK/DM refrigeration machine is designed for stand-ard water chilling applications using Refrigerant-11.

## ASME stamping

All 19DK/DM heat exchangers are constructed in accor-dance with the ANSI/ASHRAE 15-1978 Safety Code for Mechanical Refrigeration. This code, in turn, requires conformance with the ASME Code for Unfired Pressure Vessels wherever applicable.

The heat exchangers have water-side volumes less than 120 gallons (454 L), and refrigerant-side design pressures of not more than 15 psig (103 kPa). The unit is, therefore, exempt from the ASME code requirements and is not stamped.

## Design pressure

Design and test pressures for 19DK/DM unishell heat ex-changers are listed below.

### DESIGN AND TEST PRESSURES

PRESSURES	SHELL SIDE (Refrigerant)		TUBE SIDE (Water)	
	psi	kPa	psi	kPa
Design	15	103	150	1034
Hydrostatic Test	—	—	225	1551
Air Test	30	207	—	—

### UNISHELL MATERIAL SPECIFICATIONS

ITEM	MATERIAL	SPECIFICATION
Shell Water Box Shell Water Box Flange Water Box Cover Tube Sheet Tube Support Sheet	HR Steel	ASME SA285 Grade C
Tubes	Finned Copper	ASME SB359

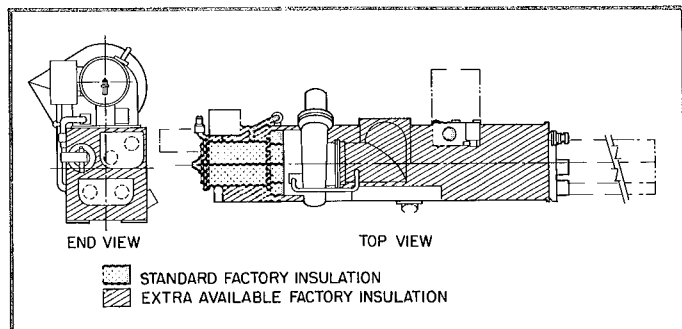

### INSULATION REQUIREMENTS

UNISHELL SIZE	EXTRA INSULATION	
	ft <sup>2</sup>	m <sup>2</sup>
50-57	131	12.2
61-65	213	19.8
71-78	218	20.3

## Insulation

**Standard insulation** — The compressor motor and purge condensing chamber are factory insulated. The insulation applied at the factory is 3/4 in. (19.0 mm) thick and has a thermal conductivity K value of 0.28 Btu • in./hr • ft<sup>2</sup> • °F (0.0404 W/m • °C). Insulation conforms with UL Standard 94. Classification 94HBF.

**Additional factory insulation (when ordered)** — The suction elbow, tube sheets, and the evaporator portion of the unishell are factory insulated if specified.

**Insulation at jobsite** — As indicated in Condensation vs Relative Humidity table, the factory insulation provides excellent protection against condensation under most operating conditions. If temperatures in the equipment area exceed the maximum design conditions, extra insula-tion is recommended and is available at customer request as shown in Insulation Requirements table.

If the cooler and the suction elbow are to be field insu-lated, obtain the approximate areas from Insulation drawing.

Insulation of water box covers is made only in the field and this area is not included in Insulation table. When insu-lating the covers, allow for service access and removal of covers.

### CONDENSATION VS RELATIVE HUMIDITY\*

AMOUNT OF CONDENSATION	ROOM DRY-BULB TEMP			
	80 F (27 C)	90 F (32 C)	100 F (38 C)	
	%Relative Humidity			
None	80	76	70	
Slight	87	84	77	
Extensive	94	91	84	

\*These approximate figures are based on 35 F (1.7 C) saturated suction temperature. A 2 F (1.1 C) change in saturated suction temperature changes the relative humidity values by 1% in the same direction.

## NOZZLE ARRANGEMENTS

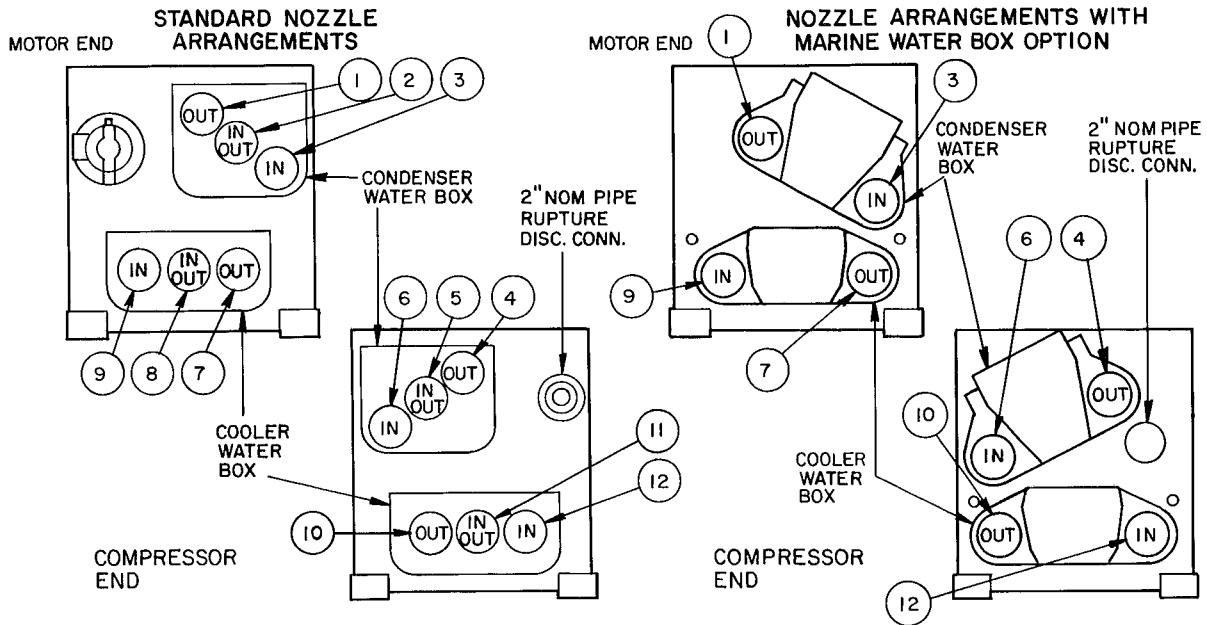

COOLER NOZZLE NO.			ARR
Pass	In	Out	
1*	11	8	P
	8	11	Q
2	12	10	R
	9	7	S
3	12	7	T
	9	10	U
4†	12	10	H
	9	7	J

CONDENSER NOZZLE NO.			ARR
Pass	In	Out	
1*	2	5	W
	5	2	X
2	6	4	A
	3	1	B
3	3	4	C
	6	1	D
4†	6	4	E
	3	1	F

\*1-pass not available for marine water box option  
 †4-pass available on 61 through 78 Size unishells only  
 Complete nozzle arrangement consists of the cooler arrangement followed by the condenser arrangement  
 For example:  
 2-pass cooler with leaving nozzle Number 10 = arr R  
 1-pass condenser with leaving nozzle Number 2 = arr X  
 Complete nozzle arrangement = RX

### Vent and drain connections

With the exception of the cooler vent connection, located in the water box shell, all vent and drain connections are found in the water box covers. Connection size is 3/4-in FPT.

Provide high points of the machine piping system with vents and the low points with drains. If shutoff valves are provided in the main water pipes near the unit, a minimum amount of system water is lost when the heat exchangers are drained. This reduces the time required for drainage and saves on the cost of re-treating the system water.

It is recommended that pressure gages be provided at points of entering and leaving water to measure pressure drop through the heat exchanger. Gages may be installed as shown in Pressure Gage Location table. Pressure gages installed at the vent and drain connections do not include nozzle pressure losses.

Use a reliable manometer to measure pressure differential when determining water flow. Regular gages are insensitive and do not provide accurate measurement of flow conditions.

### PRESSURE GAGE LOCATION

NUMBER OF PASSES	GAGE LOCATION (Cooler or Condenser)
1 and 3	One gage in each water box
2 and 4	Two gages in water box with nozzles

### Oil cooler water supply

City water or system chilled water may be used. If city water is used, it must be clean and noncorrosive. *Water-side erosion or corrosion of the oil cooler coil can lead to extensive machine damage not covered by the standard warranty.*

In addition to being clean and noncorrosive, oil cooler water must meet the following requirements.

- Max inlet temperature . . . . . 85 F (29 C)
- Max inlet working pressure . . . . . 200 psi (1379 kPa)
- Velocity in tube, fps (m/s) . . . . . 10 max — 6 min  
(3.0 max — 1.8 min)
- Flow, gpm (L/s) . . . . . 7 max — 4 min  
(26.5 max — 15.1 min)
- Pressure drop, psi (kPa) diff . . . . . 5 max — 2 min  
(34.5 max — 13.8 min)

A factory-supplied solenoid valve and a 1/4-in. FPT plug valve are provided at the oil cooler water inlet. The plug valve permits manual regulation of oil cooler water flow for close control of oil temperature. The solenoid valve permits the start and stop of oil cooler water flow.

If chilled water is used as the oil cooling medium, it enters oil cooler from the entering water of machine cooler, and drains from oil cooler into the leaving water of machine cooler. Place drain connection downstream from chilled water control element so that oil cooler water does not affect temperature readings.

# Application data (cont)

If machine has a single-pass cooler, it is advisable to pipe oil cooler drain into suction side of the chilled water pump to ensure adequate pressure drop through the oil cooler.

## Refrigerant temperature sensors

All 19DK/DM chillers are supplied with evaporator and condenser temperature sensors. With the addition of an Expanded Services Panel (ESP), all factory-installed sensor readings can be displayed by the ESP.

## Thermometers

Thermometers (field supplied) should have a temperature range of 0°F to 200 F (-18 C to 93 C).

Thermometers for measuring chilled water and condensing water temperatures are field purchased, as required, for individual jobs. It is recommended that thermometer wells be provided in cooler and condenser water piping. Wells in the leaving water pipes should be 6 to 10 pipe diameters from the water boxes. This provides sufficient distance for complete mixing of water as it leaves the heat exchanger tubes. Extend thermometers into pipe at least 2 inches (51 mm).

## Relief devices

19DK/DM machines are furnished with a rupture disc assembly. In accordance with ASME requirements, the

rupture disc is certified to burst within 5% of design bursting pressure. If local codes require other relief devices such as relief valves, they must be furnished in the field.

The total volume of the unishell (cooler and condenser together) has been taken into account in sizing the rupture disc assembly since the cooler is not isolated from the condenser.

See table on page 21 for the maximum allowable equivalent length of discharge pipe from rupture disc to atmosphere. Do not use pipe sizes smaller than the rupture disc exit fitting.

Vent relief device to outdoors in accordance with the ANSI safety code and all other codes applicable to mechanical refrigeration. *Refrigerant discharged from a safety device can displace oxygen in closed spaces and cause asphyxiation.*

## Data logging

With the addition of a Carrier Computerized Data Logging System, all sensor readings and operator codes can be automatically displayed on a personal computer screen and stored on disk for analysis. The log is an aid in scheduling maintenance and in diagnosing machine problems.

### OPERATING WEIGHT DISTRIBUTION

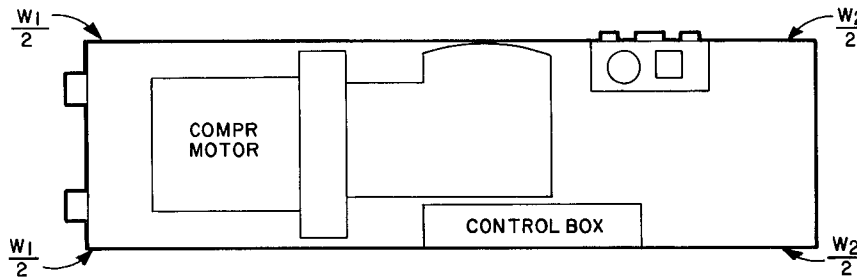

NOTE: W1 is the weight resting on the compressor motor end support plates W2 is the weight resting on the support plates at the end opposite the compressor motor

19DK UNISHELL SIZE	WEIGHT DISTRIBUTION					
	Total Operating Weight		W1		W2	
	lb	kg	lb	kg	lb	kg
42	9,136	4,144	4,928	2,235	4,208	1,909
44	9,281	4,210	5,128	2,326	4,153	1,884
46	9,446	4,285	5,328	2,417	4,118	1,868
50	10,961	4,972	6,168	2,798	4,793	2,174
51	11,191	5,076	6,373	2,891	4,818	2,185
53	11,456	5,196	6,518	2,956	4,938	2,240
55	11,716	5,314	6,663	3,022	5,053	2,292
57	11,971	5,430	6,813	3,090	5,158	2,340
61	15,412	6,990	8,791	3,988	6,621	3,002
63	15,792	7,163	8,996	4,081	6,796	3,082
65	16,122	7,312	9,186	4,167	6,936	3,145
71	17,693	8,025	10,104	4,583	7,589	3,442
72	17,953	8,143	10,249	4,649	7,704	3,494
73	18,338	8,318	10,469	4,749	8,869	3,569
76	19,078	8,653	10,789	4,894	8,289	3,760
77	19,648	8,912	11,089	5,021	8,580	3,891
78	20,108	9,121	11,389	5,166	8,719	3,955

19DM UNISHELL SIZE	WEIGHT DISTRIBUTION					
	Total Operating Weight		W1		W2	
	lb	kg	lb	kg	lb	kg
50	12,216	5,541	6,865	3,114	5,351	2,427
51	12,446	5,646	7,082	3,212	5,364	2,433
53	12,711	5,766	7,233	3,281	5,478	2,485
55	12,971	5,884	7,380	3,348	5,590	2,536
57	13,226	5,999	7,526	3,414	5,700	2,586
61	16,900	7,666	9,633	4,370	7,267	3,296
63	17,280	7,838	9,850	4,468	7,430	3,370
65	17,610	7,988	10,038	4,553	7,572	3,435
71	19,219	8,718	10,974	4,978	8,245	3,740
72	19,479	8,836	11,123	5,045	8,356	3,790
73	19,864	9,010	11,342	5,145	8,522	3,866
76	20,604	9,346	11,662	5,290	8,942	4,056
77	21,174	9,605	11,921	5,407	9,253	4,197
78	21,634	9,813	12,245	5,554	9,389	4,259

## MAXIMUM ALLOWABLE EQUIVALENT LENGTH OF DISCHARGE PIPE

UNISHELL SIZE	RUPTURE DISC NOMINAL SIZE	REQUIRED AIR DISCHARGE CAPACITY		SCHEDULE 40 PIPE SIZE (in.)					
				2		3		4	
				Maximum Allowable Equivalent Pipe Length					
lb/min	kg/min	ft	m	ft	m	ft	m		
42 — 57	2	38.6	17.5	12	3.66	100	30.5	390	118.9
61 — 65	2	50.5	22.9	8	2.44	59	18.0	238	72.5
71 — 78	2	58.5	26.5	6	1.83	44	13.4	170	51.8

### STANDARD CONTACT SURFACES

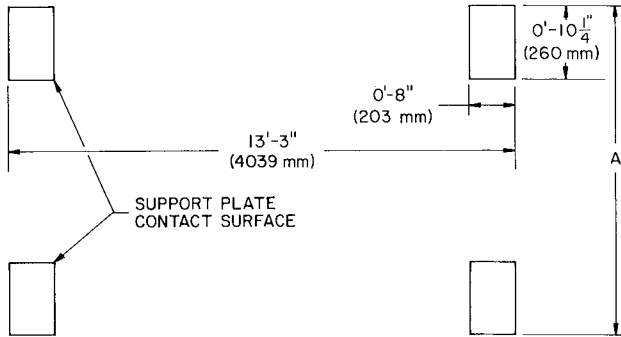

UNISHELL SIZE*	DIMENSION A	
	ft-in.	mm
42 — 57	3-0	914
61 — 65	3-10	1168
66 — 78	4-6½	1384

\*See machine informative plate

### TYPICAL SPRING ISOLATION

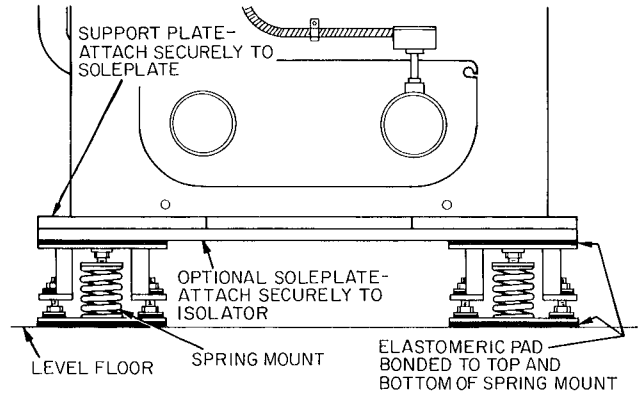

### TYPICAL ISOLATION ASSEMBLIES (Without Spring Mounts)

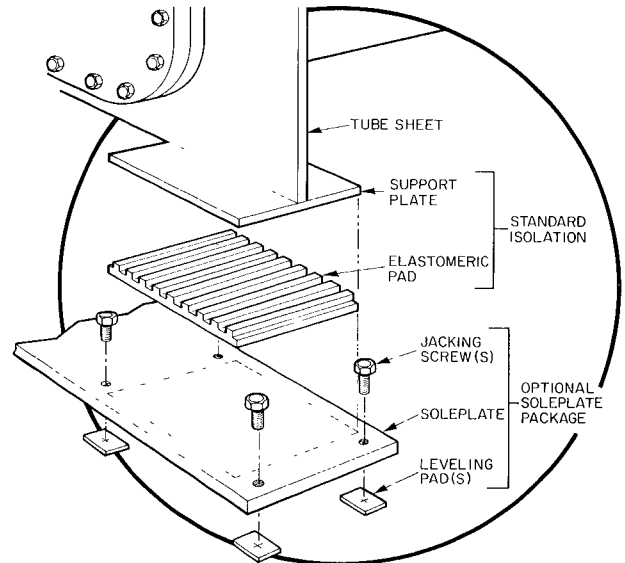

### CONTACT SURFACES WITH SOLEPLATES

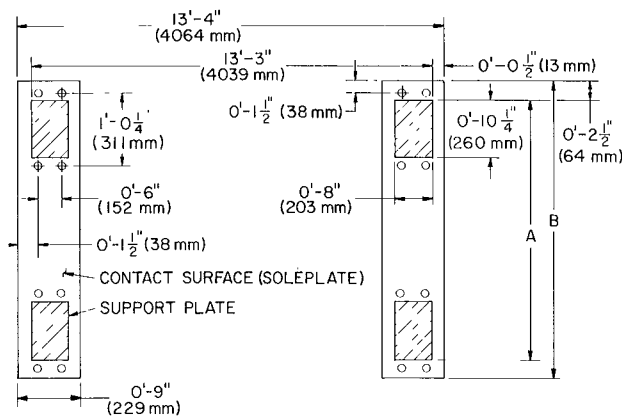

UNISHELL SIZE*	DIMENSIONS			
	A		B	
	ft-in.	mm	ft-in.	mm
42 — 57	3-0	914	3-5	1041
61 — 65	3-10	1168	4-3	1295
66 — 78	4-6½	1384	4-11½	1511

\*See machine informative plate

## Isolation

**Standard isolation** — All 19DK,DM machines are supplied with 4 elastomeric pads of resilient cross-ribbed

neoprene and 4 steel support plates that provide vibration isolation.

**Optional isolation** — When ordered, a soleplate package, containing 2 soleplates, 16 leveling pads and jacking screws,

# Application data (cont)

is shipped with the unit. The package is used in conjunction with the standard isolation.

**Spring isolation** — Certain critical machine locations may require a greater degree of vibration isolation than that provided by standard arrangements. Generally, spring isolation mounts are used in such situations. When required, mounts are field selected for the desired degree of isolation and are furnished and installed by others.

While spring isolators may be placed directly under the support plates, soleplates provide a broader support base, increase unit stability, and decrease the natural

(bounding) frequency of the unit. For individual isolator loadings, see Operating Weight Distribution table.

When applying isolators, securely fasten soleplates to the heat exchanger. If bolts are used for this purpose, drill or tap soleplates, as required, in the field.

Spring isolation requires that special consideration be given to the support and isolation of the system piping. Refer to Carrier System Design Manual for general system piping information. Also, contact the isolation equipment manufacturer for detailed information on a specific installation.

## Guide specifications

### Hermetic Water-Cooled Centrifugal Chiller

#### HVAC Guide Specifications — Section 15683

Size Range: **150 to 500 Tons, Nominal**

Carrier Model Number: **19DK/DM**

Note: Items throughout this specification which apply to the 19DM variable diffuser model are indicated with brackets [i.e.].

#### Part 1 — General

##### 1.01 SYSTEM DESCRIPTION

- A. Microprocessor controlled liquid chiller utilizing hermetic type centrifugal compressors.

##### 1.02 QUALITY ASSURANCE

- A. Chiller performance shall be rated in accordance with Air Conditioning & Refrigeration Institute (ARI) Standard 550, latest edition.
- B. Equipment and installation shall be in compliance with Safety Code for Mechanical Refrigeration, ANSI/ASHRAE 15-1978.
- C. Starter enclosure shall be NEMA 1 type.
- D. Compressor impellers shall be over-speed tested by manufacturer to a minimum of 20% above operating conditions.

##### 1.03 DELIVERY, STORAGE AND HANDLING

- A. Unit shall be stored and handled in accordance with manufacturer's instructions.
- B. Unit shall be shipped with all refrigerant piping and control wiring factory installed.
- C. Unit shall be shipped with firmly attached metal plates that indicate name of manufacturer, chiller unit model number, compressor type and refrigerant used.

#### Part 2 — Products

##### 2.01 EQUIPMENT

###### A. General:

Factory assembled, single piece, liquid chillers shall consist of compressor, motor, cooler, condenser, purge unit, lubrication system, isolation pads and microprocessor control system. Motor starter shall

be factory furnished, installed on the unit or shipped separately for field installation. An initial charge of refrigerant and oil shall be factory furnished for field installation.

###### B. Compressor:

1. One (1) single stage R-11 compressor.
2. Compressor, motor, and transmission shall be hermetically sealed into a common assembly and arranged for easy servicing.
3. Journal bearings shall be babbitt-lined and pressure lubricated.
4. Transmission gears shall be of the double helical type and must be arranged for visual inspection without disassembly or removal of compressor casing or impeller.
5. Compressor shall be provided with a factory-installed lubrication system to deliver oil under pressure to bearings and transmission gears. Included in the system shall be:
  - a. Hermetic motor driven oil pump.
  - b. Oil cooler
  - c. Oil filter.
  - d. Oil pressure regulator.
  - e. Automatic water control valve.
  - f. Thermostatically controlled oil heater.
  - g. Reservoir oil temperature gage.
  - h. Oil pump shall be provided with a separate 220, 460 or 575 volt, 3 phase, 60 Hz power source (or 230 or 400, 3 phase, 50 Hz power source).
  - i. Oil pump starter:
    - 1) Factory mounted on the chiller and factory wired to pump motor and control circuit.
    - 2) If oil pump starter is not factory mounted, all required extra field mounting and wiring is to be done at no cost to the owner
6. Compressor to be supplied with variable inlet guide vanes for capacity control
7. [When specified, compressor to be supplied with variable diffuser configuration.]

#### C. Motor:

1. Compressor motor shall be of the single speed, non-reversing, squirrel cage induction type suitable for the voltage shown on the equipment schedule.
2. Motor design speed shall be 3550 rpm at 60 Hz (or 2950 rpm at 50 Hz).
3. Motor shall be suitable for operation in a refrigerant atmosphere and shall be cooled by atomized sub-cooled refrigerant in contact with the motor windings.
4. Motor stator shall be arranged for service or removal with only minor compressor disassembly and without breaking of main refrigerant piping connections.
5. Full load operation of the motor shall not exceed nameplate rating.
6. Low voltage motors (600 v or less) shall be built for connection to Wye-Delta type reduced inrush starters.

#### D. Cooler and Condenser:

1. Cooler and condenser shall be of unishell (single vessel) construction, fabricated with high performance finned copper tubing, steel shell and tube sheets and fabricated steel water boxes.
2. Tubing shall be copper, high-efficiency type, with integral internal and external fins. Tubes shall be nominal 3/4-in. OD with wall thickness of 0.028-in. (22 ga.) (0.71 mm) measured at the root of the fin. Tubes shall be rolled into tube sheets and shall be individually replaceable.
3. Water boxes and nozzle connections shall be designed for 150 psig (1034 kPag) maximum working pressure, unless otherwise noted.
4. Water boxes shall have vents, drains and covers to permit tube cleaning within the space shown on the drawings. Suitable tappings shall be provided in water boxes and nozzles for control sensors, gages and thermometers.
5. Cooler shall be designed to prevent liquid refrigerant from entering the compressor. Devices that introduce pressure losses (such as eliminators) are not acceptable because they are subject to structural failures that result in compressor damage requiring extensive repair.
6. Tubes shall be removable from either end of the heat exchanger without affecting strength and durability of the tube sheet and without causing leakage in adjacent tubes.
7. A thermal economizer shall be provided as part of the assembly to increase cycle efficiency.

#### E. Purge System:

1. A purge system shall be furnished for chillers operating under vacuum where the ambient temperature is 75 F (24 C).
2. System shall be self-contained thermal type, provided with all necessary devices for the evacuation of air and water vapor from the system and

for condensing, separating and returning refrigerant to the system. Purge chamber shall be constructed of stainless steel.

3. Compressor type purges are acceptable but all piping and wiring between purge and chiller shall be the responsibility of the contractor.

#### F. Pumpout System:

1. A refrigerant pumpout system shall be installed on the chiller when refrigerants of higher pressure than R-11 are used. The pumpout system shall include compressor and drive, piping, wiring, motor starter and a refrigerant storage vessel. The storage vessel shall be external to the unit shells and shall be large enough to hold the entire refrigerant charge.
2. A single pumpout system, with sufficient capacity for the largest chiller, may be used in a multiple chiller application.

#### G. Insulation:

1. The compressor motor, purge chamber and miscellaneous piping shall be factory insulated by the chiller manufacturer.
2. The cooler shell, tube sheets, and suction elbow insulation can be factory applied or field applied by the contractor. The cooler water box cover shall be field insulated by the contractor after final field leak testing.
3. Insulation shall be 3/4-in. thick, fireproof, and shall have a thermal conductivity not exceeding 0.28 Btu • in./hr • ft<sup>2</sup> • °F (0.0404 W/m °C).

#### H. Vibration Isolation:

If equipment room floor is level, chiller manufacturer shall furnish isolator pads for mounting equipment on a level concrete pad. If the equipment room floor is not level, the chiller should be ordered with optional soleplates, jack screws and leveling pads for field installation.

#### I. Controls and Safeties:

1. Controls:
  - a. Control system shall be microprocessor based and fully automatic.
  - b. Start-up and shutdown shall be manual or automatic. When start-up and shutdown are automatic, external signal is required (i.e., time clock).
  - c. Capacity control shall be by means of variable inlet guide vanes located in compressor suction. Load modulation shall be from 100% to 10% of full load under normal ARI conditions without the use of hot gas bypass.
  - d. Control system shall automatically sequence the operation of the compressor depending on load and/or lift required to minimize energy usage.
  - e. Refrigerant flow control shall be accomplished through the use of a positive metering device.

# Guide specifications (cont)

- f. Factory furnished controls shall be pre-piped and pre-wired with connections to a terminal strip for interlock with other equipment
  - g. Oil pump shall have momentary contact switches to permit manual operation of the pump when the compressor is not operating. Oil pump shall be energized prior to chiller motor start-up and shall have delayed action stopping to ensure that oil pressure is provided during machine coast-down.
  - h. Installation of field wiring as shown on the manufacturer's control diagrams shall be the responsibility of the electrical contractor.
  - i. [On machines equipped with variable wall diffuser configurations, the microprocessor shall independently sense the load on the compressor (motor amps) and lift on the compressor (cooler temperature and condenser temperature.) This information shall be fed into a pre-programmed matrix. The microprocessor shall send a signal to move the variable diffuser wall to the position where optimum efficiency for that particular compressor at that particular operating condition is obtained.]
  - j. Microprocessor system shall include a programmed sequence to meet pre-lube and post-lube, pre-flow and post-flow needs prior to machine start-up and during coast-down after machine stop. The system shall assure a smooth pull down of loop temperature to prevent any power demand spikes. After shutdown, system must indicate time remaining until restart
2. Safeties:
- a. Unit shall automatically shutdown upon tripping of any of the following-listed safety devices. Each of these devices shall require manual reset and cause an alarm indication.
    - 1) Motor over-current.
    - 2) Over voltage.
    - 3) Under voltage.
    - 4) Bearing high temperature.
    - 5) Low refrigerant temperature.
    - 6) High condenser pressure.
    - 7) High motor temperature
    - 8) High compressor discharge temperature.
    - 9) Low oil pressure.
  - b. Controls shall provide override condition to automatically reduce load on chiller in the event of high motor temperature or low refrigerant temperature and shall cause a pre-alarm indication. If either condition persists, the control shall then shut down the machine.
  - c. Controls shall provide low chilled water temperature shutdown with automatic recycling to provide freeze protection at low load.
  - d. Microprocessor system shall prevent machine re-start until a safe, preset time period has elapsed.
  - e. A safety rupture disc shall be installed on the unit.
3. Diagnostics:
- a. Diagnostic display module shall be capable of indicating a safety lockout condition through the display of a two (2) digit code for which a legend shall be provided in the control panel. All of the devices listed in paragraphs I 2a. above shall be covered by the diagnostic display. Shutdown of any device shall provide a flashing display of first out indication.
  - b. A record of the last 5 failure modes (machine shutdowns) shall be stored in the memory of the diagnostics system for manual recall by an operator.
  - c. Diagnostic display module, in conjunction with the microprocessor control system, shall be capable of displaying the output of a pre-programmed start-up test to verify operation of all switches, thermistors, potentiometers, fans, pumps, motors, etc. prior to machine start-up.
  - d. Indication of elapsed time, compressor motor amps, power-on, pre-alarm and alarm conditions shall be provided.
- J. Compressor Motor Starter:
- 1. The chiller manufacturer shall furnish a separate wye-delta closed transition type starter, complete with suitable 3 leg overload protectors and NEMA 1 enclosure, for installation by the electrical contractor. Across-the-line starters shall be furnished for voltages above 600 volts.
  - 2. Chiller manufacturer shall furnish starter and control wiring diagrams for the electrical contractor.
  - 3. SPECIAL NOTE:  
If chiller control system does not contain under/over voltage protection and motor current display, then provide under/over voltage protection and an ammeter as a part of the compressor motor starter.
- K. Electrical Requirements:
- 1. The machine shall be supplied with a unit mounted and wired starter or:
    - a. Electrical contractor shall handle and install the compressor motor starter in accordance with the diagrams and instructions of the chiller manufacturer.
    - b. Electrical contractor shall supply and install all electric lines, disconnect switches, circuit breakers, electrical protection devices, and motor terminal lugs.
    - c. Electrical contractor shall provide power supply to both oil pump starter and oil heater with the characteristics as noted in the equipment schedule. Supply shall be independent of main compressor motor starter.
  - 2. Electrical contractor shall wire the flow switches in the control circuit to ensure that chiller will

not operate until flows are established and maintained.

3. Electrical power shall be supplied to the unit at the voltage, phase, and frequency listed in the equipment schedule.

#### L. Piping:

Contractor shall:

1. Supply and install the water piping to the nozzles of the cooler and condenser and shall make provisions for removal and replacement of piping when required to provide access for cleaning of cooler and condenser tubes.
2. Make water connections to oil cooler and other water supply drain and vent connections as required by equipment drawings and local codes.
3. Supply and install refrigerant vent (relief) lines to outdoors as required on equipment drawings.
4. Supply and install thermometers and gages in readily accessible locations in piping adjacent to the chiller such that they can be easily read from a standing position on the floor.
  - a. Thermometers:
    - 1) Thermometers shall be Weksler or equal; 9-in. adjustable, indicating type with glass faced metal case and separate socket.
    - 2) Thermometers shall be installed in the entering and leaving waterlines to the cooler and condenser.
    - 3) Bulbs shall project sufficiently into the pipe to accurately measure fluid temperature.
    - 4) Cases shall have extensions of sufficient length to clear insulation.
    - 5) Supply and install McDonald and Miller equal flow switches in chilled water and condenser water piping. Switches shall make contact when flow is established. Flow switches shall be installed in horizontal runs at least 5 pipe diameters downstream from any bend or tee.

Note: Optional flow switches may be factory supplied for field installation.

#### b. Gages:

- 1) Gages shall be Marsh Master or equal with 4-1/2 in. nominal diameter dial face. Scale range shall be such that design values shall be indicated at approximately mid-scale.
- 2) Gages shall be installed in the entering and leaving water lines in the cooler and condenser.

#### M. Start-up:

1. Manufacturer shall provide a factory-trained representative employed by the chiller manufacturer to perform the following services:
  - a. Leak test.
  - b. Refrigerant pressure test.
  - c. Evacuation.

- d. Dehydration.
- e. Charge chiller with refrigerant and oil.

2. Contractor shall supply the owner and the following literature as furnished by the manufacturer prior to start-up:
  - a. One (1) complete set of installation drawings.
  - b. Wiring diagrams.
  - c. Installation instructions.
  - d. Start-up instructions.
  - e. Operation and maintenance instructions.

#### N. Special Features:

Certain standard features are not applicable when the features designated by \* are specified.

1. Chiller control system shall be supplied with an Expanded Services Panel (ESP) which provides the following features:
  - a. Remote set point to permit selection and alteration of chilled water temperature from a central EMS (Energy Management System) or as a function of return chilled water temperature, remote temperature, or temperature difference across the evaporator.
  - b. Indicator panel to provide the chiller operator with instant self-diagnostic capabilities. Panel shall be located at machine or remotely (up to 1000 ft from machine).
  - c. Power demand limit to permit selection of power limit from central EMS or from stepped contact closure of 80/60/40%.
  - d. Lead-lag control shall be provided when 2 machines are installed in series or parallel. Centralized control panel with the following capabilities shall be provided:
    - 1) Parallel operation.
    - 2) Series operation with split or common control point.
    - 3) Two chiller operation.
    - 4) Uneven sized chillers working together.
    - 5) Independent control of chillers either manually or automatically.
    - 6) Reassignment of lead-lag hierarchy.
    - 7) Automatic standby.
  - e. Auto restart after power loss.

#### \* 2. Insulation:

Unit manufacturer shall furnish and install insulation on the cooler shell and suction elbow.

#### \* 3. Starter Accessories:

Starter shall be supplied by the unit manufacturer with the following accessories (specifier to indicate):

- Ammeter with 3-phase switch in starter door.
- Circuit breaker — main.
- Fusible disconnect — main.

## Guide specifications (cont)

Phase failure and phase reversal protection.  
Oil pump disconnect switch.

4. Soleplate Package:  
Unit manufacturer shall furnish for field installation a soleplate package consisting of soleplates, jacking screws, leveling pads and neoprene pads.
- \* 5. Marine Water Boxes:  
Unit manufacturer shall furnish marine water boxes on the cooler and/or condenser as specified on the equipment schedule.
- \* 6. Piping Connections:  
Unit manufacturer shall furnish Victaulic grooved piping connections on the water box covers for the cooler and/or condenser.
- \* 7. Piping Connections:  
Unit manufacturer shall furnish standard flanged piping connections on the water box covers for the cooler and/or condenser.
- \* 8. Water Boxes:  
Unit manufacturer shall furnish water boxes rated at 250 psig.
- \* 9. Cooler Tubes:  
Unit manufacturer shall provide cooler tubes of the material and with the wall thickness specified on the equipment schedule.
- \* 10. Condenser Tubes:  
Unit manufacturer shall provide condenser tubes of the material and with the wall thickness specified on the equipment schedule.
11. Spring Isolators:  
Spring Isolators, selected for the desired degree of isolation, shall be field furnished and installed.
12. Hot Gas Bypass:  
Hot gas bypass valve and piping, designed to artificially load the evaporator, shall be factory furnished and installed to permit chiller operation at less than 10% of full-load capacity for extended periods of time.
13. Computerized Data Logging:  
Data logging system, capable of handling up to 16 chillers from one centrally located personal computer, shall be provided. System shall include user programmable pre-alarm limits and selectable log print-outs. (Personal computers shall be customer supplied.)

Carrier Corporation • Syracuse, New York 13221

1194 9-88



Manufacturer reserves the right to discontinue, or change at any time, specifications or designs without notice and without incurring obligations

Book | 2  
Tab | 5a

Page 28

Catalog No 521-914

Printed in U.S.A

PC 211

Form 19DK,DM-1PD

Replaces: 19DK-1PD, 19DM-1PD