

**Carrier**

A United Technologies Company

REPLACEMENT COMPONENTS DIVISION

SERVICE BULLETIN

SUBJECT: Pre-Whirl Vane Cable Assembly**NUMBER:** CA-SB-19-C-71-58**DATE:** 10-27-98**SUPERSEDES:****DATE:****PAGE:** 1 **OF:** 20**MODELS AFFECTED:** 19C, 19CB, 17CA, 17CB Compr's

Installation, repair and service and equipment referenced in this Service Bulletin should be undertaken only by qualified persons. Carrier Corporation: (1) makes no representations or warranties, expressed or implied, concerning the accuracy, completeness or right to use the information contained herein. (2) Disclaims all liability for injuries, damages, infringements and other losses which may arise on account of, or which may result from, the use or application of any information, method or apparatus disclosed herein.

PURPOSE:

To outline a revised procedure for replacing the prewhirl vane cable assembly.

GENERAL:

Recently there have been several significant improvements in the vane cable design. This bulletin outlines the new parts needed and gives a suggested method of installing a new vane cable and the recently improved parts.

NOTE: Complete vane cable assemblies are available from Carrier Parts Center which can be installed instead of restringing this assembly in the field.

SPECIAL MATERIALS REQUIRED:

1. Torque wrench – ½” drive (0-110 Ft.-Lbs.)
2. 5/16” Allen wrench for ½” drive.
3. Vice grip pliers.
4. Special fixture to hold vanes in closed position (Fig. 4).
5. Shim stock (.010) to space pulley hubs (Fig. 7).
6. Special socket to fit drive pulley slot (Fig. 6).
7. Two cotter pins 3/32” x 1-1/4” long (steel).

SERVICE BULLETIN

8. Two or three spare shims, Carrier part no. 19C47-2062 for hydraulic motor piston.
9. 30 inches of 20 gauge wire. (To secure fillister head screws which hold shims on bottom of piston.)
10. Container to drain hydraulic cylinder.
11. Wire jumper.
12. 3/8" and 1/2" flare plug (two of each to plug oil lines).
13. Short piece of 3/8" copper tubing for siphoning oil nut of hydraulic cylinder.
14. Leveling type protractor. (Protractor with a leveling bubble on its base).

Order from Service Parts, Syracuse, one (1) cable and pulley package, fifteen (15) or seven (7) vane pulley packages (depending on size of compressor) and (16) idler pulley packages. See chart on Fig. 8 for part numbers according to machine size.

ELECTRONIC MACHINES:

Before starting the step-by-step procedure outlined below, the hydraulic cylinder must be drained of oil. With the machine under vacuum, use the following procedure:

1. Operate the oil pump and run the hydraulic motor to the fully open position (Top of cylinder). This can be done by installing a jumper wire between terminals 1 and 18 on the control panel and then depressing the "higher" manual button.

On 19CB-jumper between  and  and 

2. Shut off oil pump and remove the wire jumpers.
3. Remove and plug the oil line to the rack and gear chamber. This line may be 3/8" or 1/2".
4. Open the needle valve to the hydraulic piston. With the machine under vacuum the piston will be forced to the cover end of the cylinder, draining the oil to the reservoir.
5. Remove the rack and gear chamber cover plate and siphon the oil left on top of the piston.
6. Break the machine vacuum.

SERVICE BULLETIN

PNEUMATIC MACHINES:

On pneumatic machines it is only necessary to remove the rack and gear inspection cover and remove the small amount of oil in this chamber. The spring will keep the vanes and the piston in the closed position. Then break vacuum.

REPLACING THE PREWHIRL VANE CABLE:

Disassembly – Refer to Figures 1, 2 and 3.

1. Remove the inlet venturi from the compressor.
2. Force the hydraulic piston all the way to the bottom of the hydraulic cylinder. This is the normal position of the piston when the vanes are closed.
3. No mark on the drive pulley is needed because a new one will be installed.
4. Remove the blade ring assembly from the inlet venturi. Place on a table or bench with the gas entering side up. (Idler pulleys (4) up.)
5. Place the vanes in a closed position. The thick edge of the blade should turn toward the entering gas when opening. Looking at the end of the drive pulley vane shaft, it turns clockwise to close and counterclockwise to open. Some vanes have one side oval and one side flat. These vanes should have the flat side toward the entering gas when closed.
6. Place the fixture (Fig. 4) in position with one disc on each side of the blades. Install braces and tighten down holding bolt.
7. Loosen pipe plugs on all pulleys including the drive pulley until the pulleys turn free. Install vice grips the opposite way shown in Fig. 11. The vice grips should be resting against idler pulley #2 and the wrench turning counterclockwise.
8. Remove the cable and discard. Save the nuts and washers.
9. MARK THE BLADE RING SO THAT THE NEW DRIVE PULLEY WILL BE INSTALLED IN THE SAME POSITION AS THE OLD ONE. Remove all pulleys (idler pulleys also).

SERVICE BULLETIN

10. Remove fixture and remove all vanes. Number the vanes and holes in order to return them to their original location.
11. Inspect vane shaft bushings (18) and (6). On R-114 machines there will be a ball bearing and a needle bearing on each vane. Replace any that show wear or are hard to turn. Use the 19C Service Parts catalog to order correct bushings and for the ball or needle bearing part numbers.

Assembly – Refer to Figures 1, 2 and 3 for item numbers.

1. Install guide vanes (7) and thrust washers (17) (R-11, R-113). Be sure the thick edge of the blade turns toward the entering gas when vane opens. The vane shaft turns clockwise to close and counterclockwise to open when looking at the end of the vane.
2. Install new idler pulleys (4) using nut (13), bolt (11), and washer (12). Be sure retaining clip (23) is in place as shown on Fig. 2. Use new bushing supplied with idler pulley package. See Fig. 12. See that they turn freely once they are tightened.
3. Install new vane pulleys (3). Be sure thrust washer (17) (R-113, R-11) is in place. Also install new drive pulley (2).
4. Install pipe plugs (14) with teflon tape. Do not tighten yet.
5. Bend retaining clips (23) on idler pulleys (4) outward slightly so that the cable may be placed into the groove on the idler pulley.
6. String the new vane cable (8) as shown in Fig. 9. Note that the alternate idler pulleys are on different bolt circles. The cable is thus guided into the vane pulleys, either on the inside or the outside of the vane pulley grooves so that the cable will not come in contact with itself and rub. (Note that Fig. 9 shows the old style vane pulleys and does not show the new retaining clips.)
7. Check to be sure that the beads on the cable are lined up properly in the slots on each pulley (Fig. 5).
8. Tighten the cable (8) by taking up evenly on the nuts (15) and (9) at each end of the cable. Be sure cotter pins (16) are in place as shown on Fig. 3, view D-D.

SERVICE BULLETIN

9. Place the special socket (Fig. 6) in the slot on the drive pulley and rotate the pulleys and blades back and forth through approximately 90 degrees fifteen or twenty times. This will distribute the cable tension evenly on the pulleys.
10. With all the pipe plugs still loose, secure a vane pulley next to the drive pulley with vice grips as shown in Fig. 10. This prevents the whole cable from moving as torque is applied to the drive pulley.
11. Apply 42 Ft. Lbs of torque to the drive pulley. Tighten up slack, using nuts (9) and (15) until snug. (Fig. 10.)
12. Rotate the drive pulley ten or fifteen times to distribute the cable tension.
13. Repeat steps 10 and 11 and recheck tension (Fig. 10).
14. Install the fixture (Fig. 4) to hold the vanes closed.
15. Set the new drive pulley (2) to an index angle of $37\text{-}1/2^\circ$ from the horizontal plane or $52\text{-}1/2^\circ$ from the vertical plane, using the leveling type protractor (item 14 on the special materials list), see Fig. 3. Scribe an index mark on the new drive pulley and blade ring once the correct angle has been made.
16. Insert .010 in shim between blade ring and drive pulley.
17. Strike vane hub inside the blade ring to seat the vane shoulder against the inner thrust washer (17).
18. Strike the drive pulley with rubber mallets to move it against shim.
19. Be sure .010 clearance is maintained between drive pulley and outer thrust washer (17) (R-11, R-113). On R-114 machines clearance is between drive pulley and the blade ring.
20. With the vice grips still installed on a vane pulley, Fig. 11, line up the scribe marks on the drive pulley and blade ring.
21. Torque drive pulley pipe plug to 100 Ft. Lbs. Use a torque wrench. Be sure to remove .010 shim.

Be sure the scribe marks still line up on the drive pulley and blade ring. The wrong index angle may cause the cable to lift off one of the radii of the drive pulley.

SERVICE BULLETIN

22. Torque the remainder of the pipe plugs to 100 Ft. Lbs. (Fig. 11). Be sure to remove shim after each plug is tightened.
23. Remove the fixture holding the vanes closed.
24. Be sure the entire assembly turns freely and there is no binding. The cable must not rub together when it crosses in the pulleys. Separate the cable with a screwdriver if it touches anywhere. Rotate the drive pulley for this check.
25. With the vanes fully closed, adjust the socket head screw (19) until there is .010 to .030" between blades (Fig. 13). Lock the screw with nut (20).

Rotate the drive pulley. If it should interfere with the blade ring casting, grind off until it does not rub. Grind either the pulley or the blade ring – whichever is more convenient.

26. Install retaining clip (15) on each vane pulley. Use the bolt (21) and nut supplied in the pulley package. The vane pulley will have a slot and hole drilled in it. (Fig. 12) Peen over the bolt so that the nut could never back off.
27. Install the vane assembly into the inlet venturi.
28. Place the vanes on their closed mechanical stop (step 25). Be sure the piston is bottomed in the cylinder at this point. If it is not, the shims must be adjusted.

NOTE: If shims are adjusted, it will affect the vanes closed switch. This will affect those machines with the 7L type purge only.
29. Assemble compressor except for suction elbow.
30. Operate the vanes several times and observe the operation.
31. Check the operation of the vane closed switch.

IT IS MANDATORY THAT THE TORQUE REQUIREMENTS IN THIS BULLETIN ARE ADHERED TO.

SERVICE BULLETIN**LEGEND**

ITEM	REQ.	DESCRIPTION
1	1	BLADE RING
2	1	DRIVE PULLEY
3	15	PULLEY (VANE)
4	16	IDLER PULLEY
5	16	BUSHING
6	16	BUSHING
7	16	PRE-WHIRL BLADE
8	1	CABLE ASS'Y
9	2	NUT 5/16 – 24
10	2	WASHER – 5/16
11	16	SHOULDER SCREW
12	16	LOCKWASHER – ½
13	16	LOCKNUT ½-13
14	16	PIPE PLUG – 3/8
15	2	JAM NUT 5/16 – 24
16	2	COTTER PIN 3/32 DIA. X 1-1/4 STL.
17	32	THRUST WASHER
18	16	BUSHING
19	1	SCR. HEX. SOCKET ¼ - 20 X 2 LG.
20	1	HEX. NUT ¼ - 20
21	15	#4 – 40 BOLT X 1 ½ LG. - #4 – 40 NUT
22	15	RETAINING CLIP
23	16	RETAINING CLIP

FIGURE 1

SERVICE BULLETIN

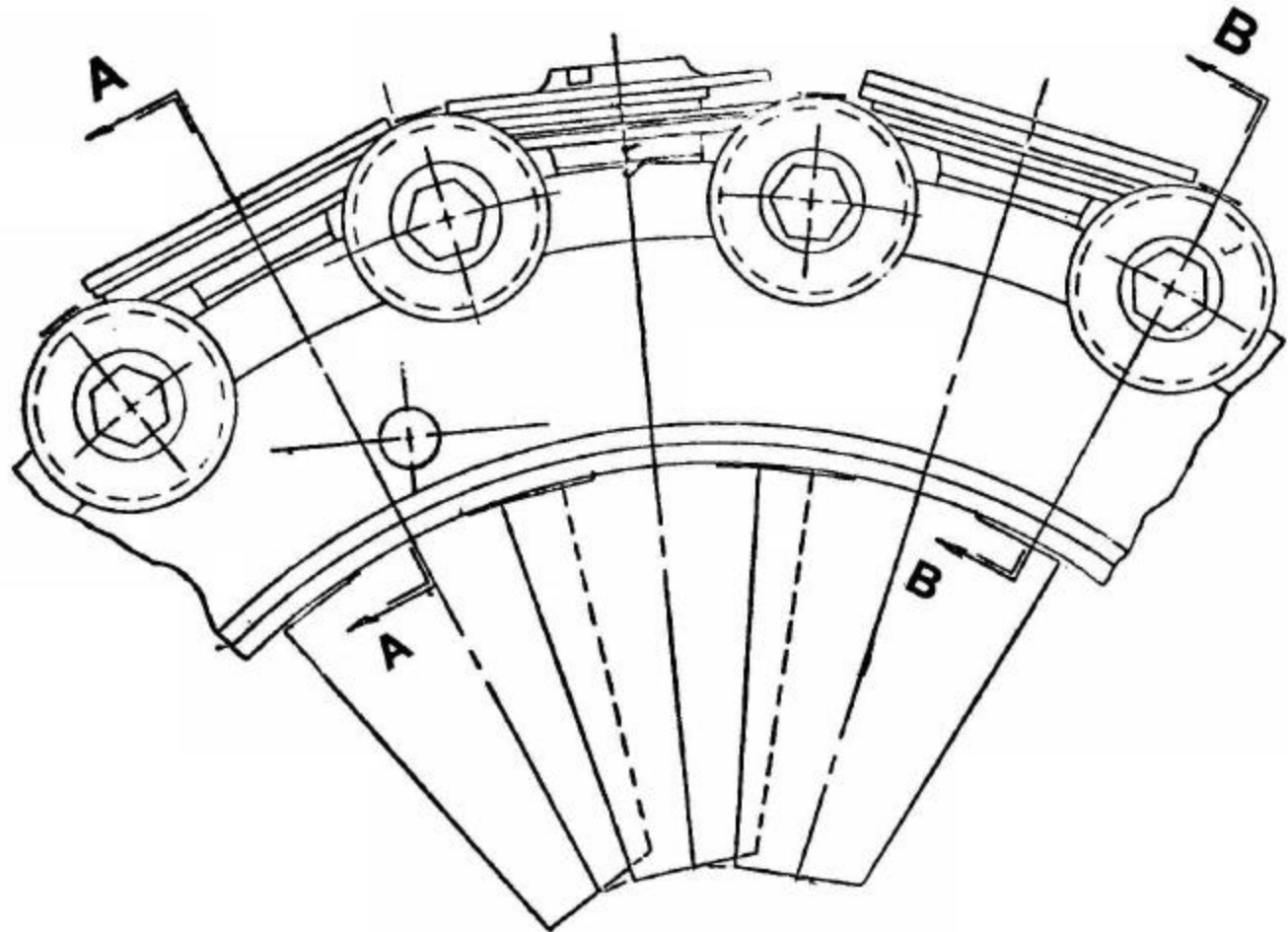
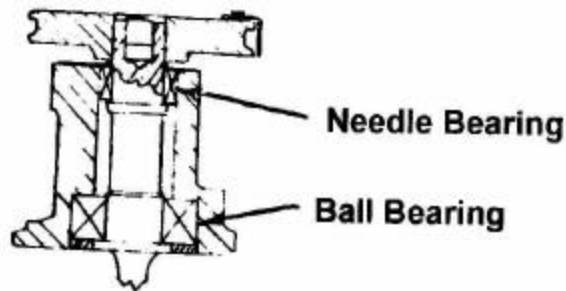
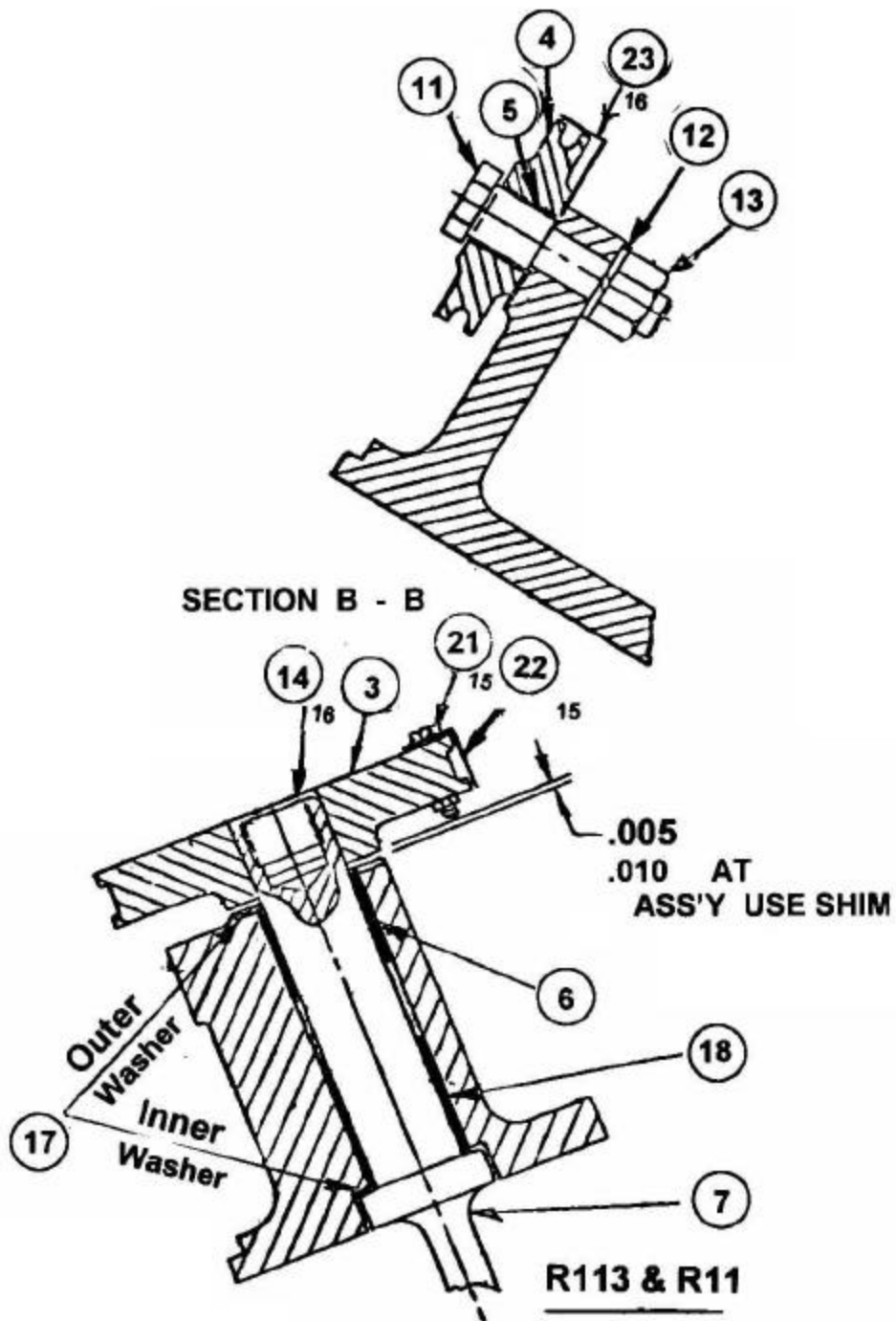

Figure 2



R-114

SERVICE BULLETIN



SECTION A - A

SERVICE BULLETIN

METHOD OF HOLDING VANES

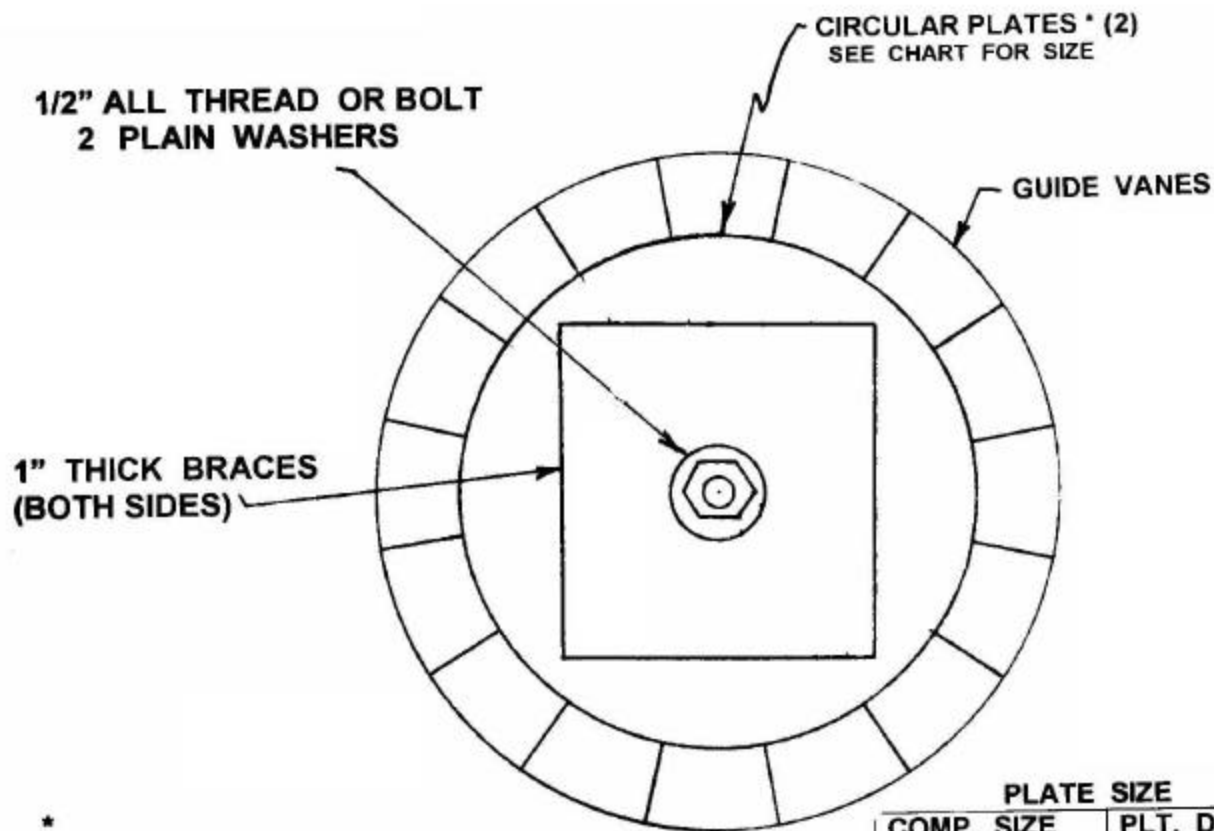

*
**PLATES MAY BE 1" PLYWOOD
 OR 3/8" STEEL PLATE**

PLATE SIZE		
COMP. SIZE		PLT. DIAM.
3	R-113	12"
4	R-113	12"
6	R-11	12"
5	R-113	17"
7	R-11	17"
8	R-11 R114	17"

FIGURE 4

SERVICE BULLETIN

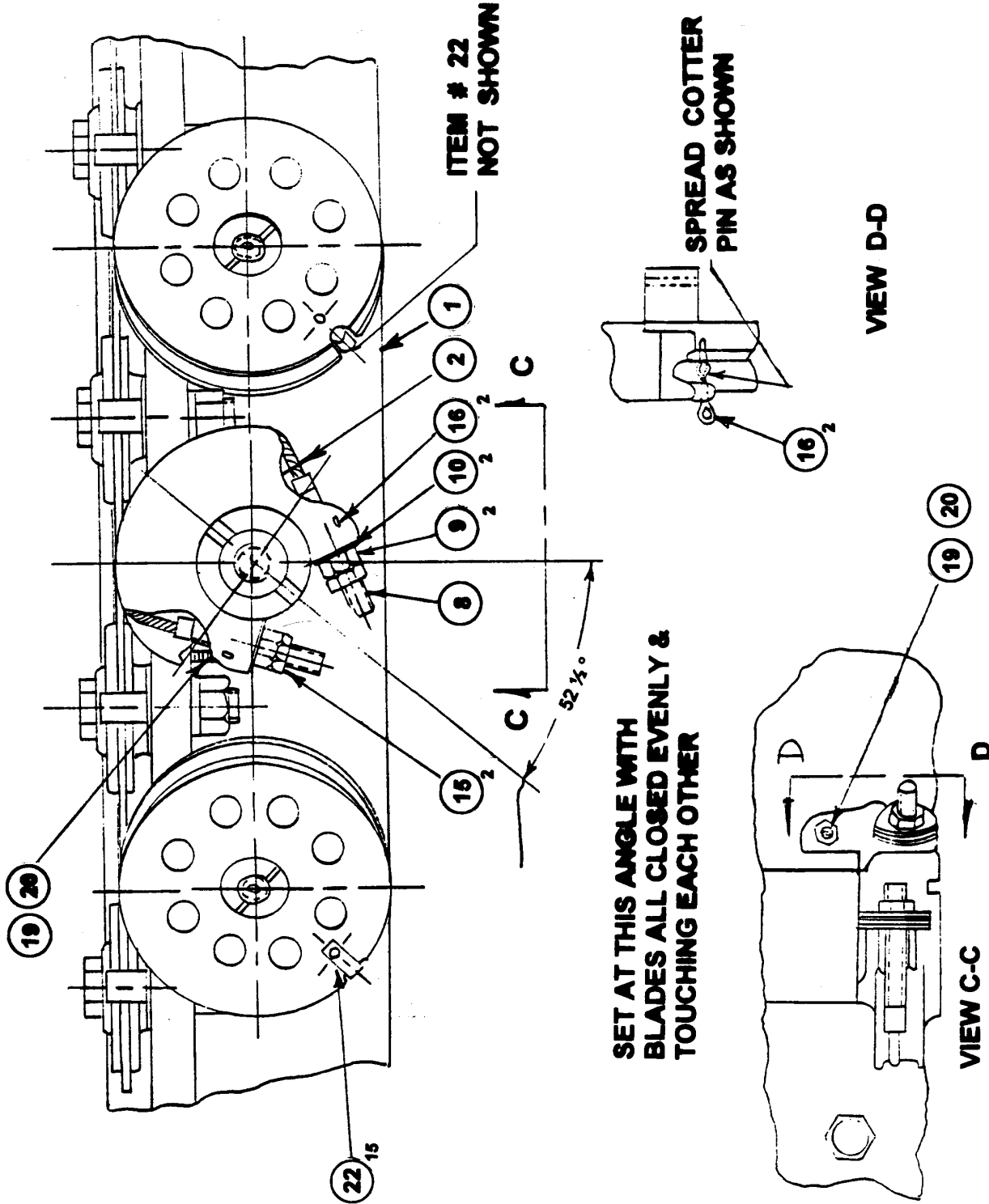
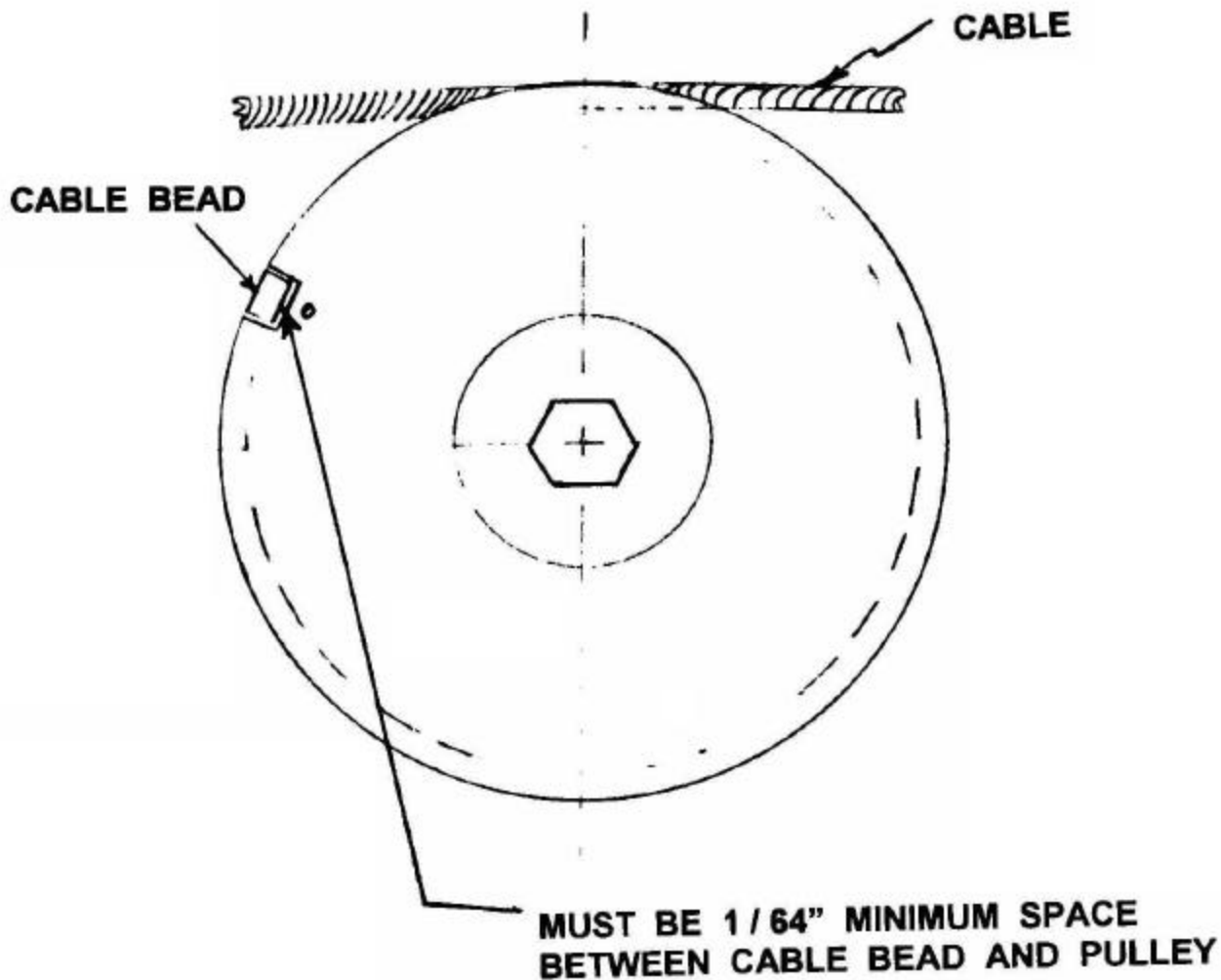

FIGURE 3

SERVICE BULLETIN



VANE PULLEY (SHOWN WITHOUT CLIP INSTALLED)

FIGURE 5

SERVICE BULLETIN

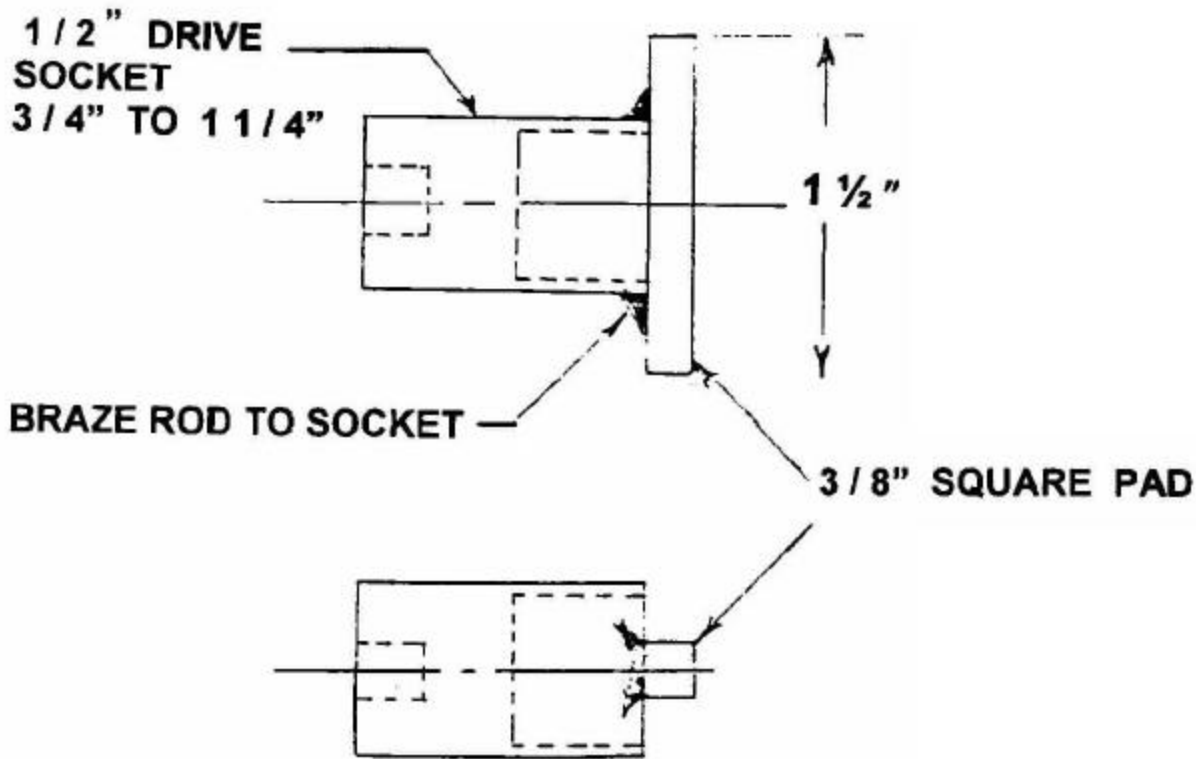

SPECIAL SOCKET

FIGURE 6

SERVICE BULLETIN

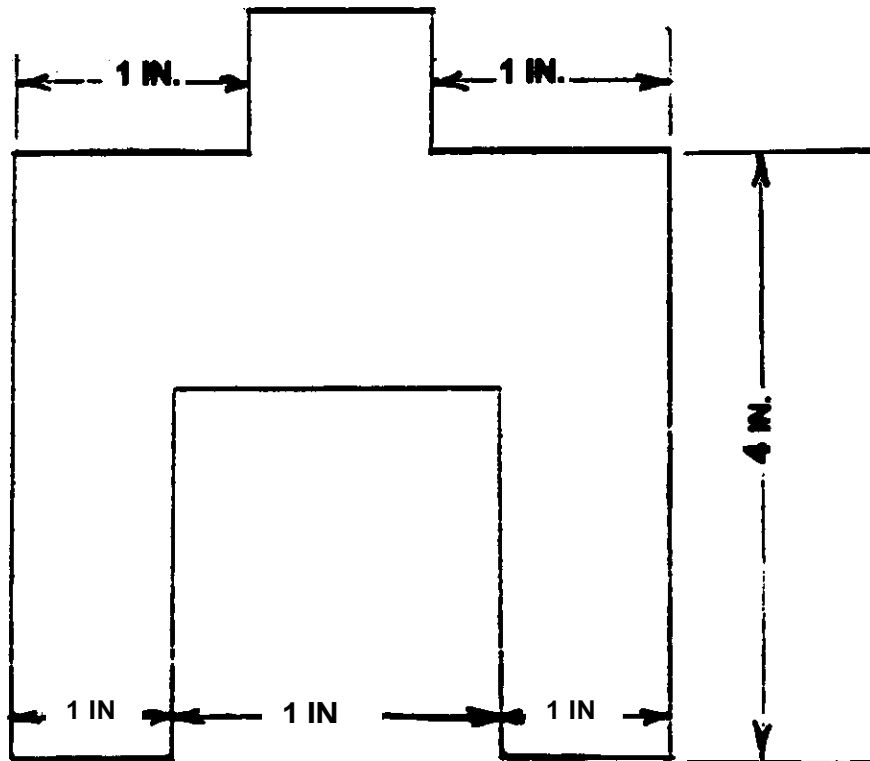

BRASS SHIM

.010 IN. THICK

1 REQUIRED

FIGURE 7

SERVICE BULLETINNEW PARTS NEEDED FOR 19C VANE ASSY.

		19C SIZE					
	PART NO.	3	4	5	6	7	8
VANE PULLEY PACKAGE Consisting of: Pulley, Clip, Nut, Bolt	19C36-791	7	7	15	15	15	15
IDLER PULLEY PACKAGE Consisting of: Pulley Bushing Clip	19C47-771	16	16	16	16	16	16
CABLE & DRIVE PULLEY PACKAGE	19C37-761	1	1				
Consisting of:	19C76-761			1		1	
Cable, Drive Pulley	19C46-761				1		
Nut, Bolt	19C87-761						1
DRIVE PULLEY PACKAGE Consisting of: Drive Pulley Nut Bolt	19C87-781	1	1	1	1	1	1
		Quantity Needed Per Job					

FIGURE 8

SERVICE BULLETIN

STRINGING NEW CABLE

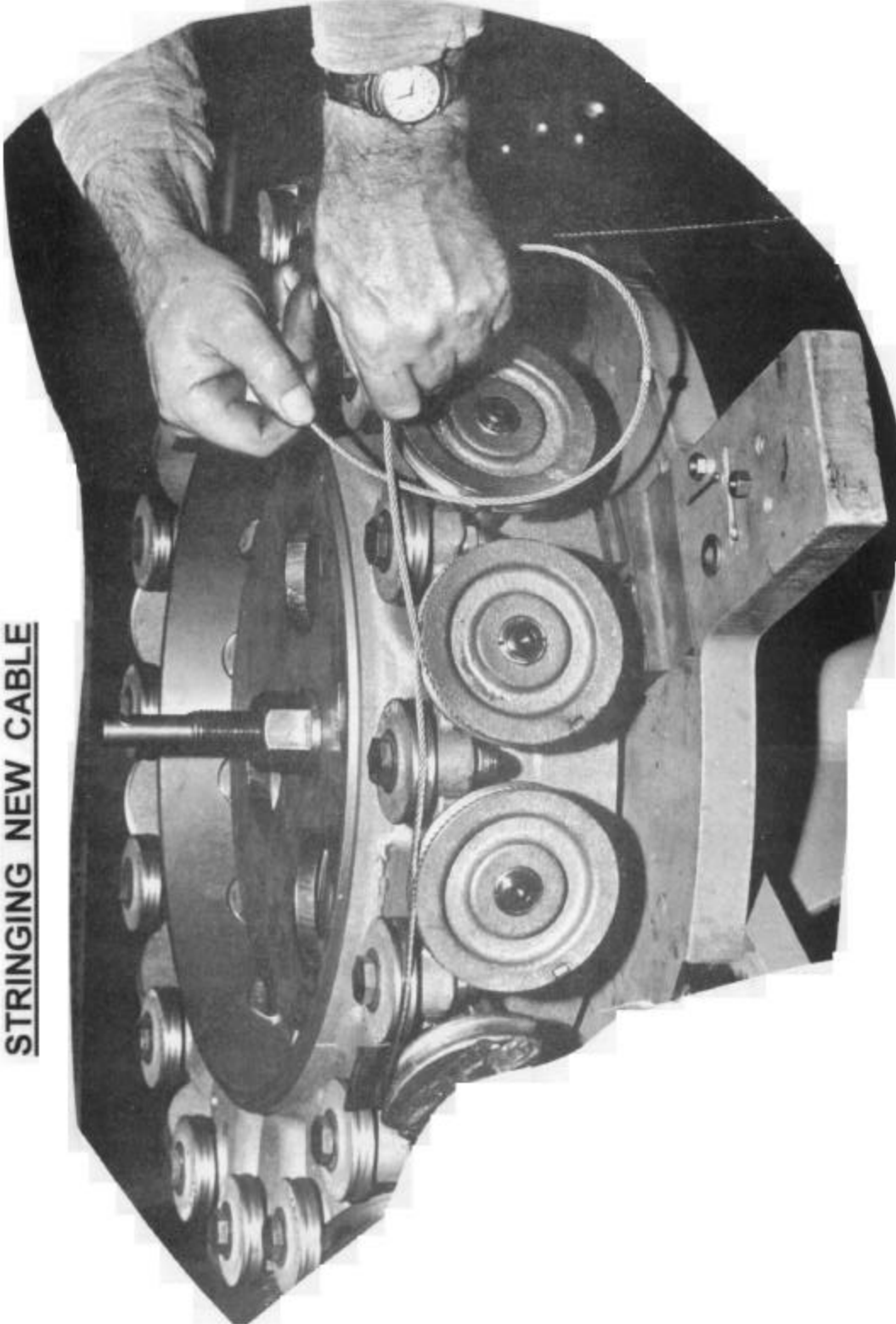
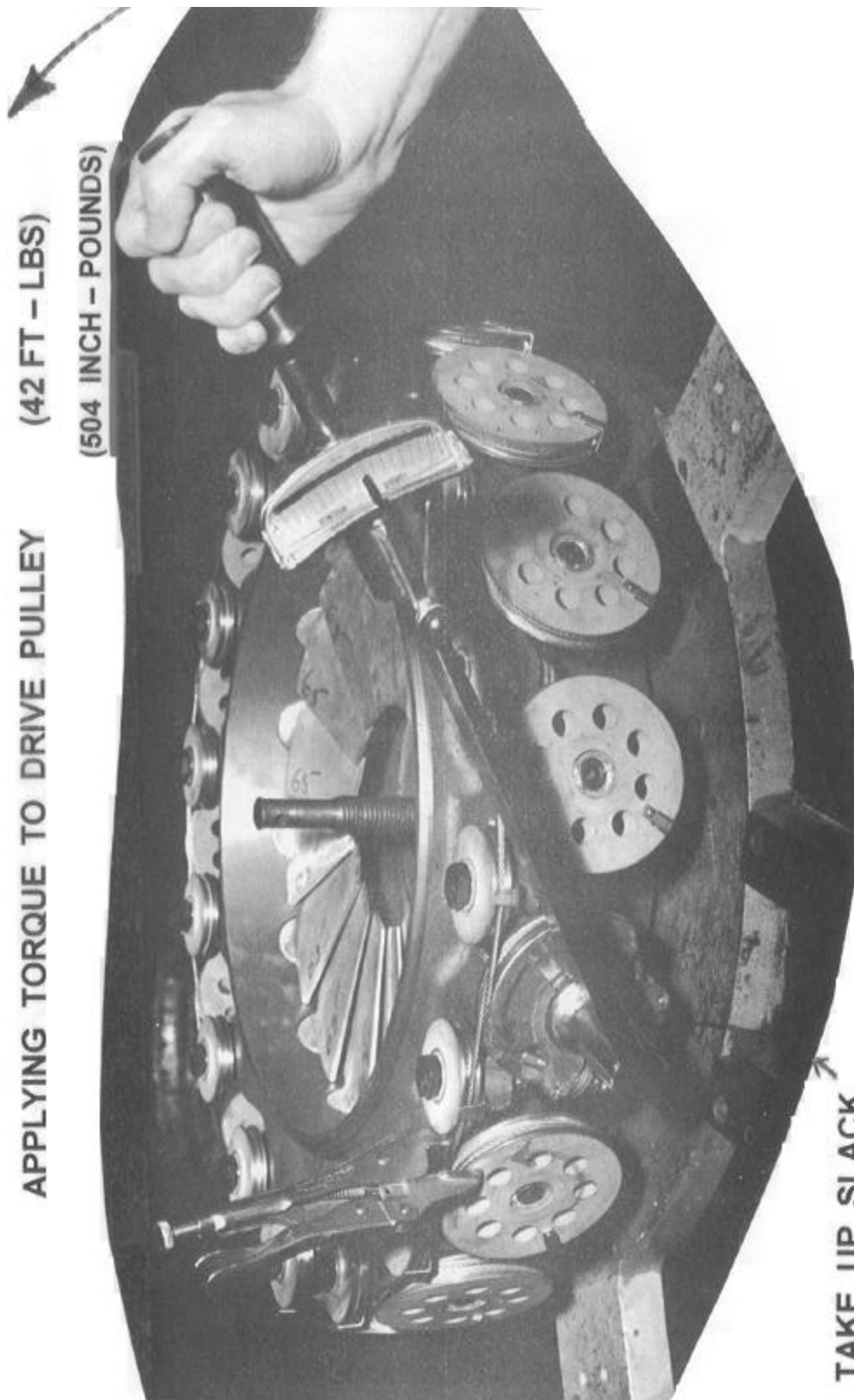

FIGURE 9

SERVICE BULLETIN



APPLYING TORQUE TO DRIVE PULLEY
(42 FT - LBS)
(504 INCH - POUNDS)

TAKE UP SLACK
HERE

FIGURE 10

SERVICE BULLETIN

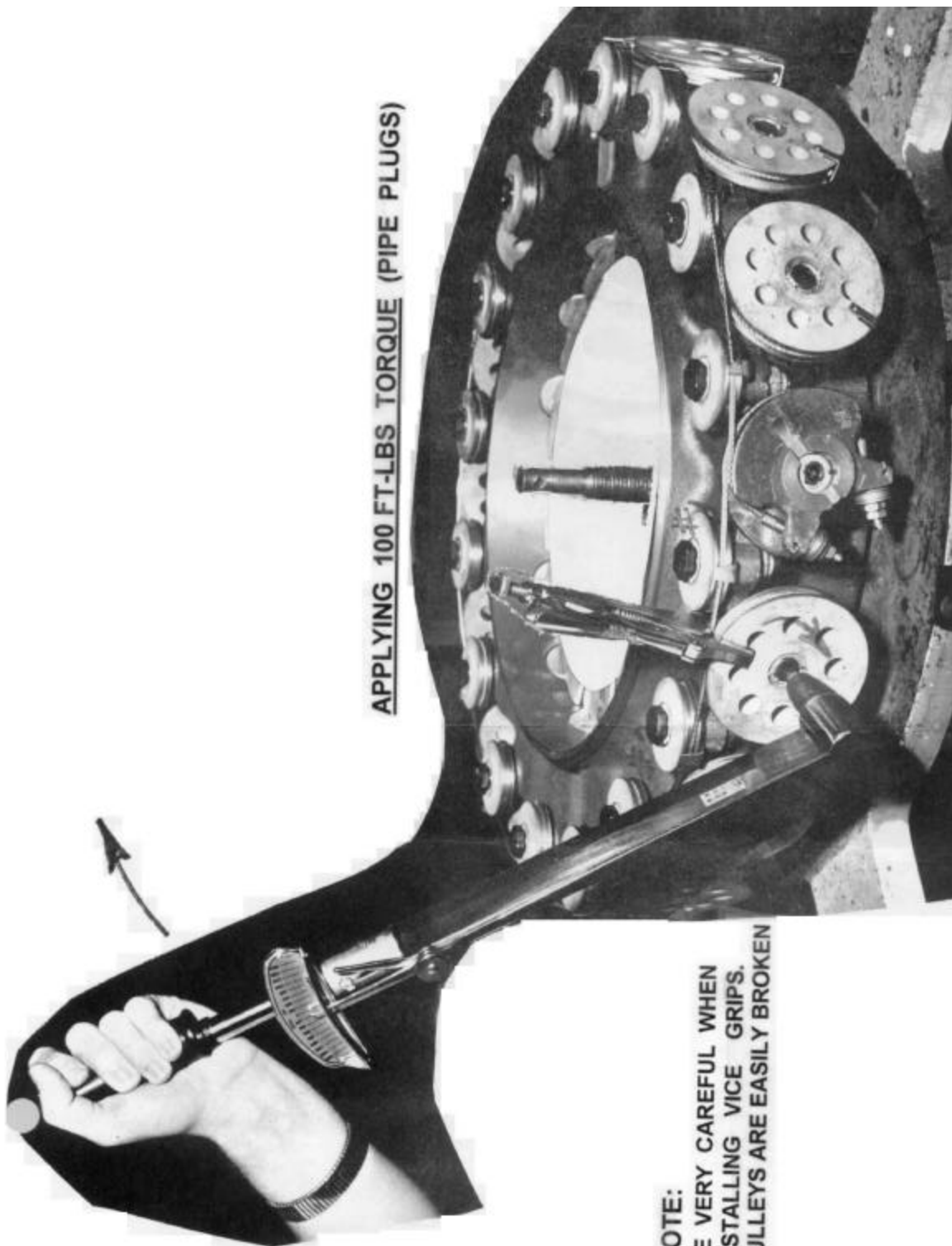

FIGURE 11

SERVICE BULLETIN

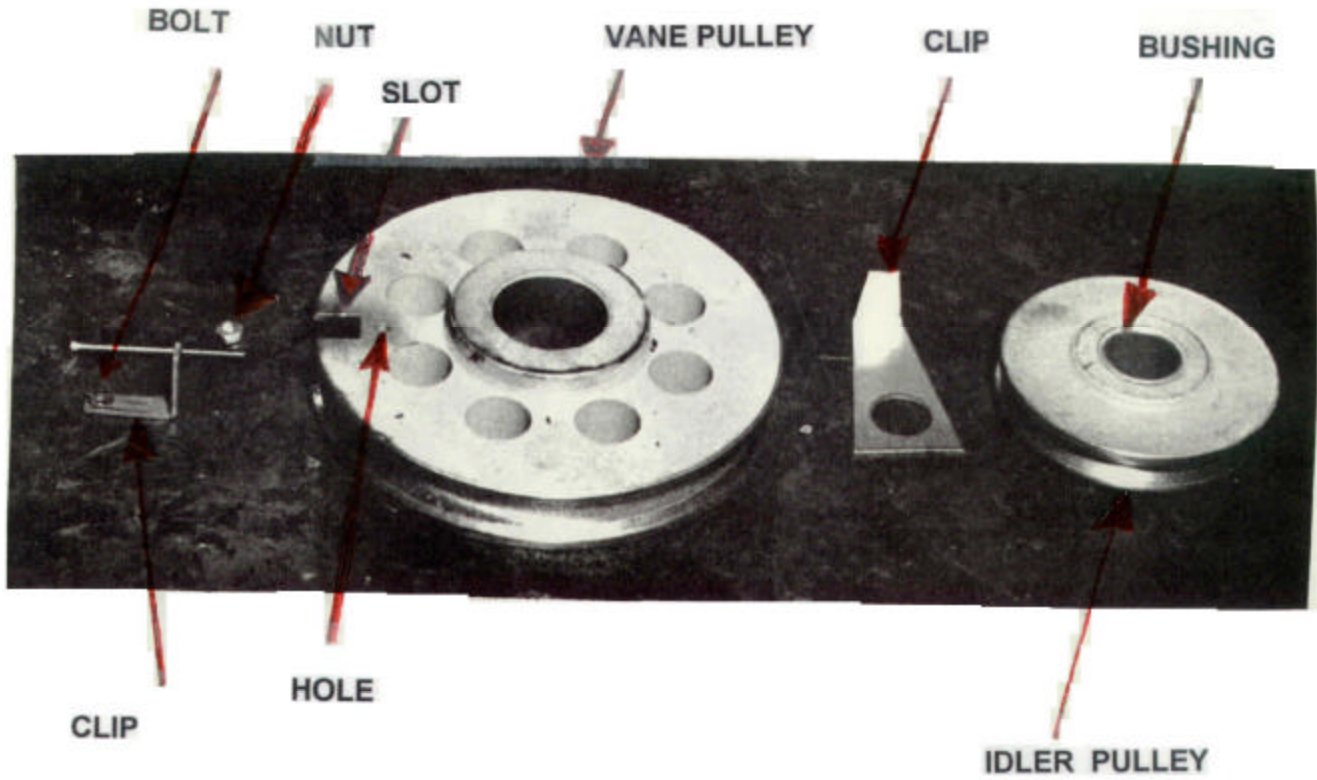

FIGURE 12

SERVICE BULLETIN

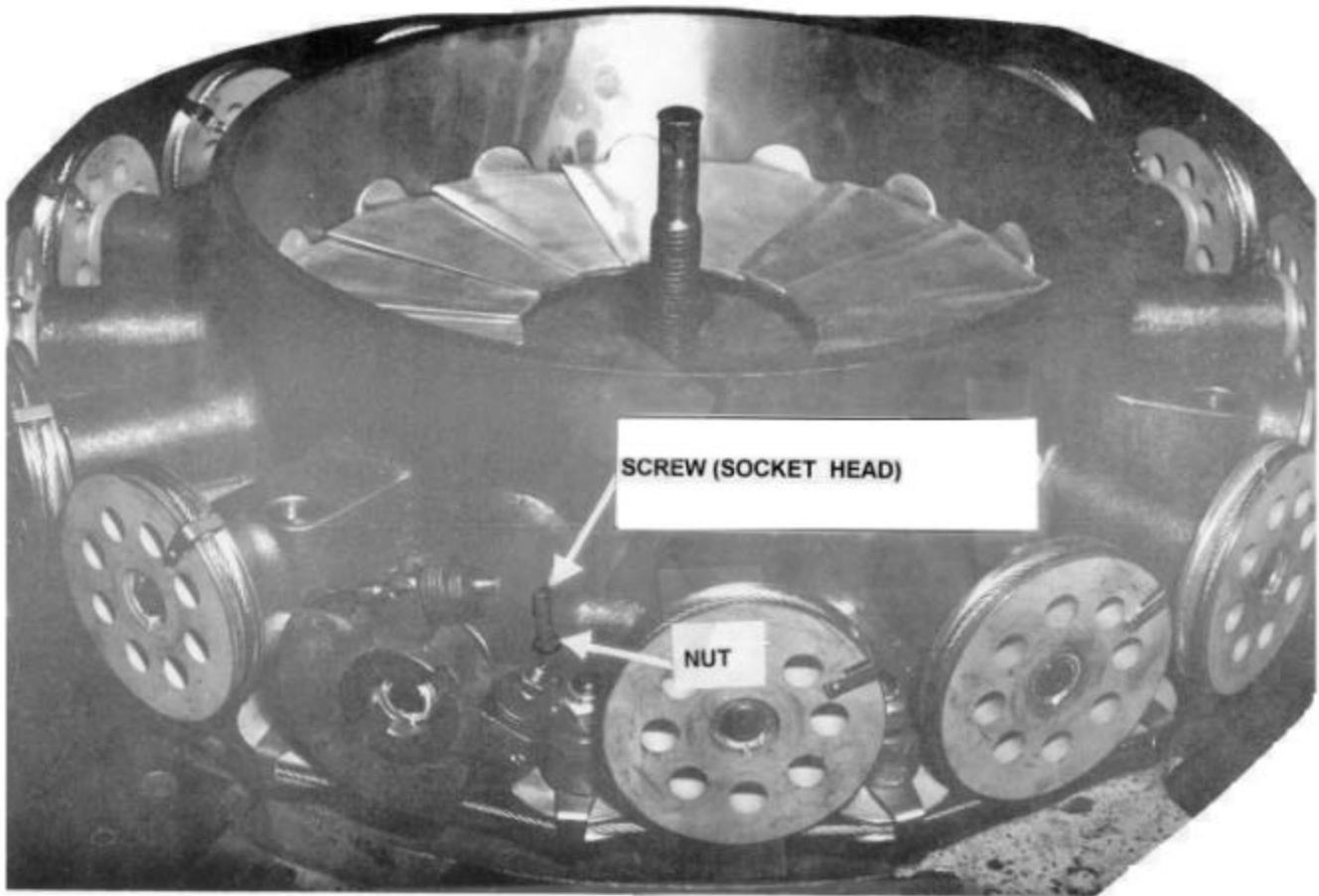

FIGURE 13