



Number: **C0124** Date: **6/21/01**

Supersedes: C9408

Date: 8/25/94

Title: 19EA/EB Oil Overheating

Category:

Termination Date:

Author: Scott Nieforth

Dept: CSS Service Engineering

Models: CAC: 19EA / EB5

Affected: BDP:

PURPOSE:

This bulletin describes modifications required to prevent high thrust bearing oil temperatures when 19EA/EB5 chillers are converted to higher speed gears or converted to ice storage duty. This revision includes piping instructions for an alternate oil cooler.

BACKGROUND:

Changing a chiller's refrigerant to R-134a or its application to ice storage duty may require impeller speeds to be increased. Higher shaft speeds will increase thrust bearing oil temperatures.

PROCEDURE:

In anticipation of this problem, the diameter of the oil flow orifice in the bearing housing can be enlarged from 0.136" to 0.170" as shown in Figure 1. This modification will increase oil flow to the thrust bearing.

Alternatively, if the problem appears after the conversion is completed, the existing oil cooler can be replaced with a larger 17DA71-2012 oil cooler. The 1-1/2" NPT water flow connections are on the end of the oil cooler. Figure 2 shows the water entering the top connection and leaving the center connection of this 4 pass cooler. The 2" NPT oil connections are on the top of the oil cooler shell.

FILE: Compressor, Motor, Drive, Gears

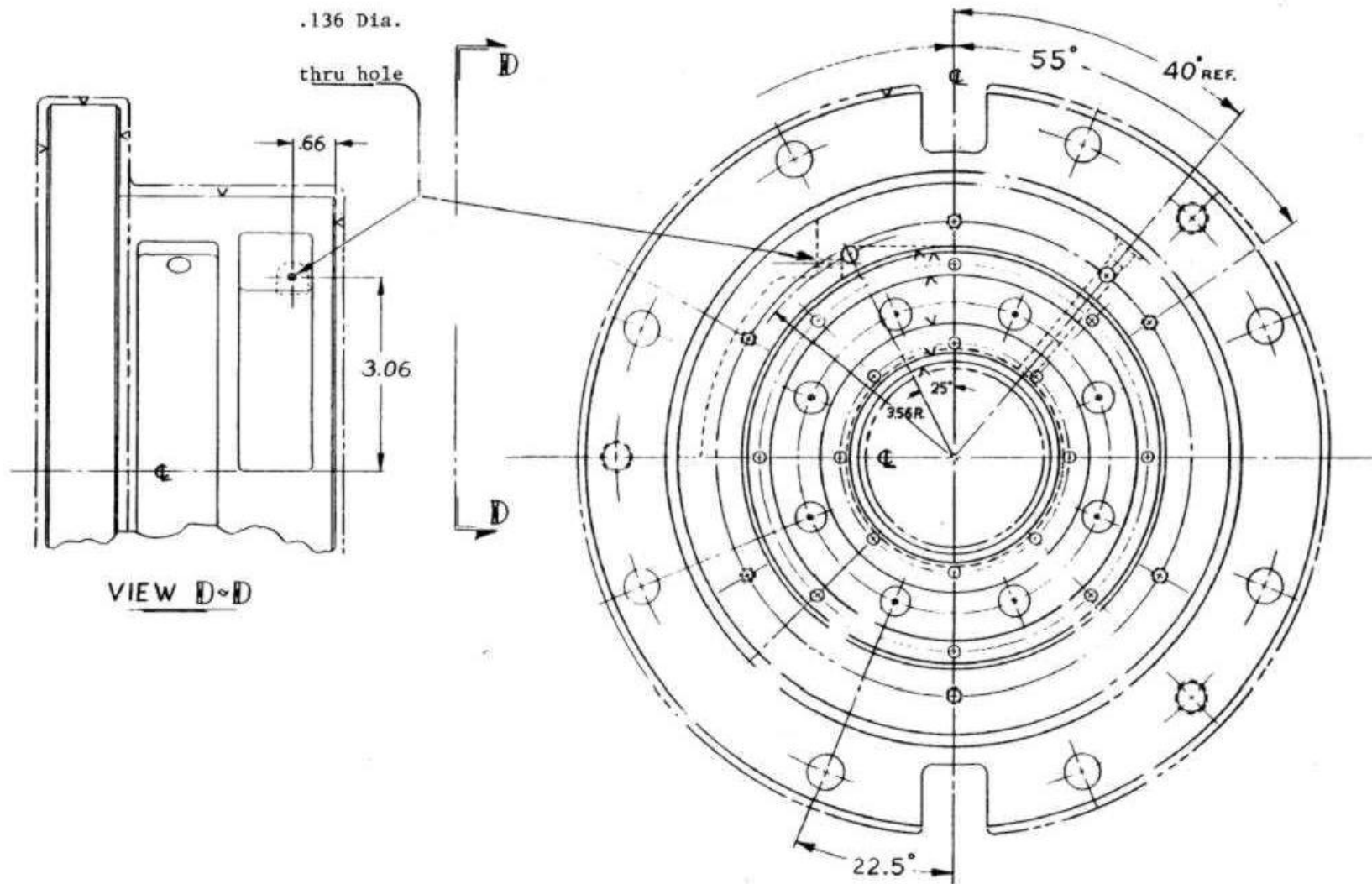

FIGURE 1: 19EA / EB5 THRUST BEARING HOUSING

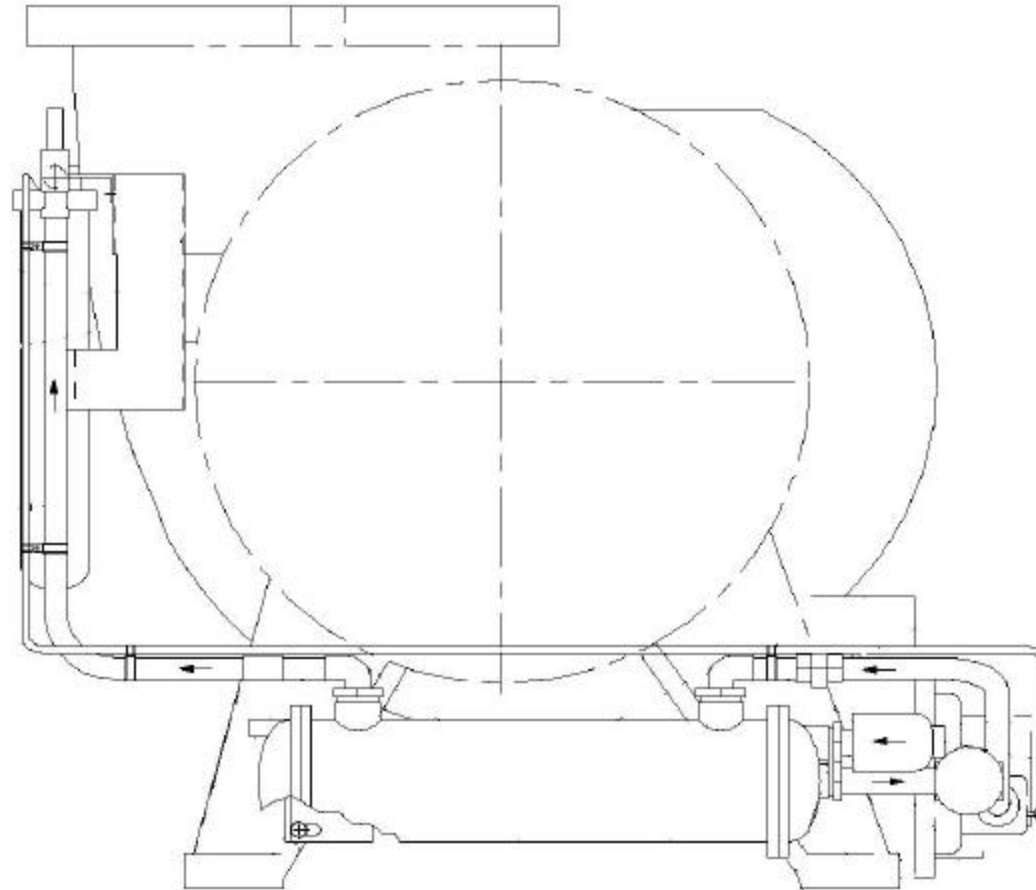

FIGURE 2: 17DA71-2012 OIL COOLER INSTALLATION