



SERVICE BULLETIN

Title: VaporSaver Installation
Models Affected: 17/19 Series

Number: C9508
Date: 3/16/95
Supersedes: New
Date:

Purpose:

To advise that the outlet piping configuration of some VaporSavers may be incorrect.

Background:

It has been discovered that some VaporSavers are installed incorrectly. The inlet and outlet adapters have been interchanged. With this case, the valve might not open properly.

File: Cooler-Condenser-Economizer

Prepared By: Richard Martin

Approved By: Alan Johnson

This document and the material contained herein are the property of Carrier Corporation and may not be copied, reproduced, or released without written permission of Carrier Corporation.

Requirement:

SERVICE MANAGERS MUST VERIFY PROPER INSTALLATION!

It is REQUIRED that a 4" section of pipe at least 13" in length be installed directly at the discharge of the relief valve, even if the vent pipe is less than 4".

Information:

When VaporSaver's are ordered, two sizes, (dimensions) are given; the inlet pipe size and the discharge pipe size. These determine the adapters provided. The inlet adapter will transition from the inlet pipe to the relief valve and the discharge adapter will transition back to the discharge pipe. All relief valves are 4" nominal. So, adapters are required. All inlet adapters are threaded flanges. The discharge adapters transition from the 4" flange of the relief valve, through a 15" long reducing bell, to the discharge pipe size specified, (2" or 3" threads). Only the 4" discharge adapter is a threaded flange. In this last case, at least 13" of 4" pipe at the discharge is required. The 4" pipe and discharge adapters cause flow patterns to make the valve "snap acting".

What has been happening is the inlet and outlet adapters are reversed. This places a threaded flange, (2" or 3") on the discharge of the relief valve. The small hole will not let the valve open fully, limiting the flow.

It is IMPERATIVE that these valves be installed correctly.

See drawing and instructions attached, and in the VaporSaver guide dated 4/30/93.

OSECO/BPS CFC CONTAINMENT UNIT ASSEMBLY & INSTALLATION INSTRUCTIONS

All new OSECO/BPS CFC Containment Unit installations should be located to allow full unrestricted discharge when overpressure conditions occur within the system protected by this unit. Never locate this unit where the discharge from the unit outlet directly impacts personnel or equipment.

Please remember that the rupture disk within this unit is a precision piece of equipment. Avoid scratching, bending denting or otherwise damaging the dome and/or flat seat areas of the rupture disk. **Do not install any rupture disk which has visible signs of damaged!**

The assembly of the OSECO/BPS CFC Containment Unit should be performed by qualified personnel. All instructions should be read and understood before assembly, installation, operation or service is performed. The following procedure should be followed for the assembly of the OSECO/BPS CFC Containment Unit:

1. Preassemble the OSECO Rupture Disk/Holder assembly as per instructions included in the Rupture Disk box. These are items 2 and 4 of the Installation Drawing SK-0403F, Sheets 1 and 2, included herewith. Check for proper Rupture Disk and Holder orientation to assure that the inlet and outlet is properly aligned. The rupture disk, item 4, will fit within the FRDI holder, item

2, only one way without a force fit which will damage the rupture disk. **Never install a damaged rupture disk!**

2. Make up the eight (8) 5/8" x 5 1/2" stud bolt with nuts, item 9, with only one nut on the end of each stud. The remaining nut will be utilized once assembly/installation is complete at the unit inlet.
3. Insert the 5/8" x 5 1/2" stud bolts with a single nut, item 9, into the inlet side of the Inlet Adapter Flange, either item 12, 13, 14, 15 or 16, depending on the size of the containment unit required. Lay Inlet Adapter Flange with inserted stud bolts with a single nut, item 9, on a flat surface for further assembly.
4. Place Flange Gasket (item 8, 1 of 4) on Inlet Adapter Flange, either item 12, 13, 14, 15 or 16, depending on size.
5. Place preassembled Rupture Disk/Holder Assembly, items 2 & 4, on top of first Flange Gasket, item 8. Please check for proper orientation of flow for inlet and outlet of holder and rupture disk. The arrow on the rupture disk holder name tag should be pointing toward the containment unit outlet.
6. Place second Flange Gasket, item 8 on downstream side of preassembled Rupture Disk/Holder Assembly, items 2 & 4.
7. Position the Flanged Canister, item 1, above the second Flange Gasket, item 8, and while aligning this unit with the inserted stud bolts with single nut, item 9, lower this unit on to the

second Flange Gasket, item 8, such that the inserted studs protrude through the bolt holes of the flange.

- 8.** Install the remaining nut for each of the eight 5/8" x 5 1/2" studs, item 9, and tighten in a typical sequential procedure to recommended torque. Refer to Rupture Disk/Holder, items 2 & 4, Assembly Installation Instructions for proper torque. See Step 1 on previous page.
- 9.** Place third Flange Gasket, item 8, on top of Flanged Canister, item 1.
- 10.** Insert 4" BPS Model MBF Pressure Relief Valve, item 3, into Flanged Canister, item 1, so that bottom face of Pressure Relief Valve contacts the Flange Gasket, item 8.
- 11.** Place fourth Flange Gasket, item 8, on outlet side of Pressure Relief Valve, item 3.
- 12.** Place Outlet Flanged Adapter, either item 12, 13, 14, 15 or 16 on top of Flange Gasket, item 8, and align bolt holes with those of Flanged canister, item 1. The Outlet Flanged Adapter is a pipe flange with a suitable concentric reducer attached for the 2 and 3 inch sizes, whose overall length is approximately fifteen (15) inches. The 4 inch Outlet Flanged Adapter is simply a threaded 4 inch flange.
- 13.** Insert eight (8) 5/8" x 4" studs with two nuts each, item 10, into the aligned bolt holes of the Flanged Canister, item 1, and the Outlet Flanged Adapter, either items 12, 13, 14, 15 or 16. After making the nuts up to a "finger tight" condition, tighten in a typical sequential procedure to a recommended torque. In the absence of piping torque specifications, use the same torque published for the rupture disk (see step 1 or 8 above).

14. Install 3/8" x 1/4" Reducer Bushing, item 11, in the 3/8" NPT opening in the Flanged Canister, item 1, shell.
15. Make the Telltale Assembly, item 5, which consists of 1 1/4" x 4" Nipple, 1 1/4" Tee, and 1 1/4" Excess Flow Valve. The Excess Flow Valve is a bi-directional valve and must be installed to maintain code requirements. The Telltale Assembly must be installed in the horizontal plane.
16. Install the assembled Telltale Assembly, item 5, in the outlet side of the 3/8" x 1/4" Reducer Bushing, item 11, installed in step 14.
17. Install the Pressure Gauge, item 7, into open branch outlet of the 1/4" Tee in the Telltale Assembly, item 5.
18. Install the 3/8" Pipe Plug, item 6, into remaining 3/8" NPT opening of the Flanged Canister, item 1, shell.
19. **Please note that the Outlet Flanged Adapter described in step 12 above, cannot mount directly to the chiller. The concentric reducer portion of the Outlet Flanged Adapter is designed to mount directly on the valve discharge via the flange portion of the adapter to allow proper functioning of the valve.**

Mounting the Outlet Flanged Adapter directly to the chiller will prevent the valve from functioning properly and void the warranty. The discharge from the Containment Unit must have a fifteen (15) inch long concentric reducer section to properly function in sizes 2" and 3". The 4" size unit may be discharged directly into 4" piping. All discharge piping must be

sized in accordance with published guidelines such as ASHRAE 15, latest revision.

Carefully connect the preassembled OSECO/BPS CFC Containment Unit to the chiller housing NPT outlet. Adequate structural support must be provided for the Containment Unit to prevent damaging the chiller.

20. It is recommended that Teflon tape or pipe thread dope be used when making up all threaded connections.

It is recommended that the Model "MBF" Pressure Relief Valve be removed from service, visually inspected, cleaned, and pressure tested annually. If factory service is required, the Pressure Relief Valve should be returned to the manufacturer.

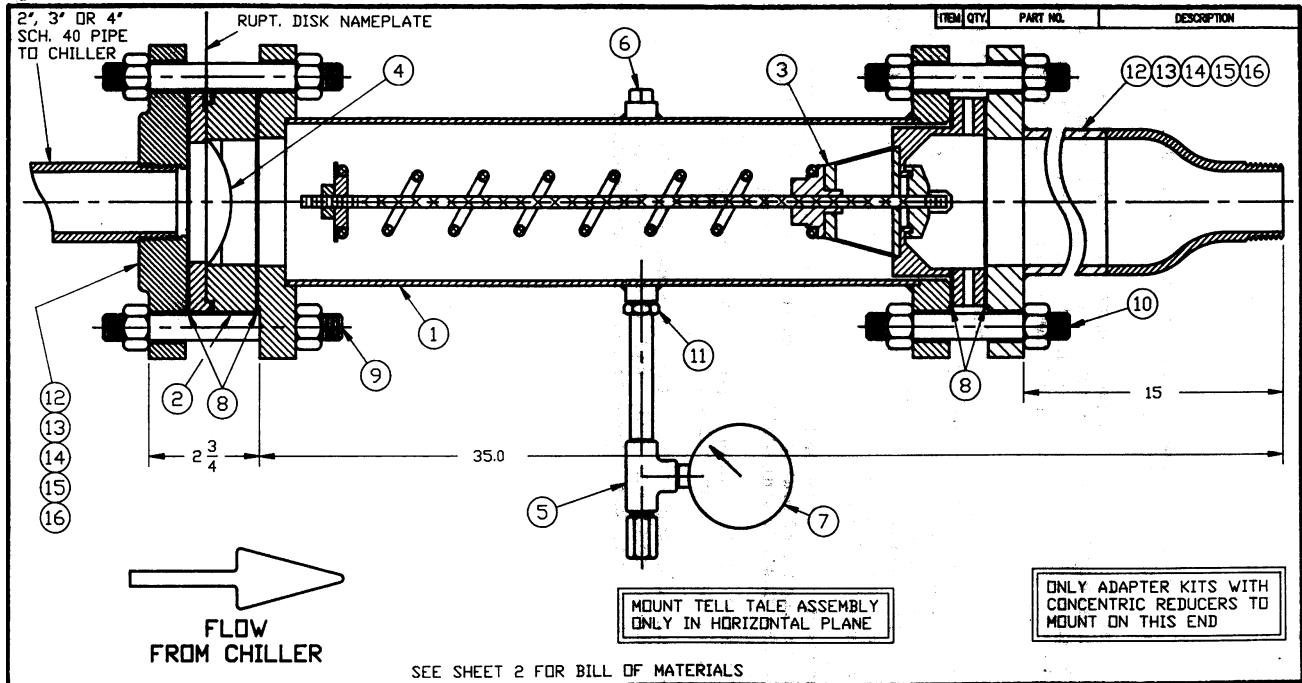

| | | | | | | | | |
|-----|---|----|------|---|---|--------------------|---|--|
| B | Revised per installation instruction. Comments added sheet 3 of 3 | BM | 4/95 | Tolerance Unless Otherwise Noted: .xxxx ±.0005 .xxx ±.005 .xx ±.01 .x ±.03 Angles: ±2° Fractions: ±1/32 Finish: 125 RMS | Oklahoma Safety Equipment Co. 1701 West Tacoma 74012 Broken Arrow, Oklahoma (918)-258-5626 | Drawn By: B Miller | Installation Illustration for 4" (F) Disk/Valve Ass'y | |
| A | Added notes "Adapter Kits" & "Mount Tell Tale Ass'y" & Flow From Chiller" | BM | 2/95 | | | Date: 8/92 | | |
| Rev | Description | By | Date | | | | | |

| CARRIER P/N | ITEM | QTY | OSECO P/N | DESCRIPTION |
|-------------|------|-----|--------------|--|
| | 1 | 1 | J91-0407-005 | 4"150 FLG CANISTER, CS-NI PLATED, (2) 3/8" NPT |
| | 2 | 1 | J91-0407-X04 | ASS'Y, 4" 150# FRDI DR PRDI SPECIAL, CS |
| | 3 | 1 | G96-0933-015 | 4" MBF RELIEF VALVE, SET 15#, CS-NI PLATED |
| | 4 | 1 | D04-XX90-XXX | DISK, 4"(F) COV DR SSR, NON-FRAGMENTING |
| | | | | BURST PRESSURE 15 PSIG @ 60°F |
| | 5 | 1 | A02-0107-001 | TELL TALE ASS'Y, NIPPLE-TEE-EXCESS FLOW VALVE |
| | 6 | 1 | A43-0207-001 | PIPE PLUG, 3/8" NPT, SQ. HD., CS |
| | 7 | 1 | A52-0030-113 | GAGE, 30"HG-30#, BRONZE TUBE, 1/4" NPT |
| | 8 | 4 | A06-0414-991 | GASKET, 4" 150# |
| | 9 | 8 | X50-0516-022 | STUD/ 2 NUTS, ALLOY STEEL |
| | 10 | 8 | X50-0516-016 | STUD/ 2 NUTS, ALLOY STEEL |
| | 11 | 1 | A43-0487-004 | REDUCER BUSHING, 1/4"NPT FEMALEx3/8"NPT MALE |
| CT32EA020 | 12 | 1 | X99-0009-069 | 2" INLET x 2" OUTLET FLANGED ADAPTER KIT |
| | 13 | 1 | X99-0009-070 | 2" INLET x 4" OUTLET FLANGED ADAPTER KIT |
| CT32EA030 | 14 | 1 | X99-0009-071 | 3" INLET x 3" OUTLET FLANGED ADAPTER KIT |
| CT32EA040 | 15 | 1 | X99-0009-073 | 4" INLET x 4" OUTLET FLANGED ADAPTER KIT |
| CT32EA035 | 16 | 1 | X99-0009-077 | 3" INLET x 4" OUTLET FLANGED ADAPTER KIT |

CARRIER TO PROVIDE THEIR PART NUMBERS

OSECO PART NO. J04-05000-00X

CARRIER PART NO. SEE SHEET #3

Sheet 2 of 3 B – See Sheet 1 of 3 OSECO Part No. J04-05000-00X

A – See Sheet 1 of 3 Carrier Part No. See Sheet # 3

| MODEL | MX SIZE | REFRIGERANT | RELIEF PRES. | CARRIER P/N | INLET/OUTLET |
|-----------------|--|-------------------------------|--------------|--|------------------------------|
| 17M | Q3-Q8 | CFC-11 HCFC-123 | 15 PSIG | 19DK660-011 | 3' / 3' |
| 17M | Q8.5-Q11 | CFC-11 HCFC-123 | 15 PSIG | 19DK660-012 | 4' / 4' |
| 19C | Q1-Q13 DESIGN #1 Q1-Q15 DESIGN #2 | CFC-11 CFC-113 HCFC-123 | 15 PSIG | 19DK660-011 (#1) 19DK660-015 (#2) | 3' / 3' (#1) 2' / 2' (#2) |
| 17CA | Q12-Q15 | CFC-11 CFC-113 HCFC-123 | 15 PSIG | 19DK660-011 | 3' / 3' |
| 19C | Q14-Q23 DESIGN #1 Q16-Q23 DESIGN #2 | CFC-11 HCFC-123 | 15 PSIG | 19DK660-012 (#1) 19DK660-011 (#2) | 4' / 4' (#1) 3' / 3' (#2) |
| 17CA | Q16-Q23 | CFC-11 HCFC-123 | 15 PSIG | 19DK660-012 | 4' / 4' |
| 17CA, 19C | Q22-Q23 | CFC-114 | 50 PSIG | 19DK660-013 | 4' / 4' |
| 17CB, 19CB | 211, 311, 411, 511 | CFC-11 HCFC-123 | 15 PSIG | 19DK660-011 | 3' / 3' |
| 17CB, 19CB | 611, 711 | CFC-114 | 50 PSIG | 19DK660-014 | 3' / 4' |
| 19D, DA, DG, DH | | CFC-11 HCFC-123 | 15 PSIG | 19DK660-015 | 2' / 2' |
| 19DK, DM | 42, 44, 46, 50, 51, 53, 55, 57 | CFC-11 HCFC-123 | 15 PSIG | 19DK660-015 | 2' / 2' |
| 19DK, DM | 61, 63, 65, 71, 72, 73, 76, 77, 78 | CFC-11 HCFC-123 | 15 PSIG | 19DK660-011 19DK660-015 | 3' / 3' 2' / 2' |
| 19/17DR | ALL SIZES | CFC-11 HCFC-123 | 15 PSIG | 19DK660-011 | 3' / 3' |

Sheet 3 of 3 B – See Sheet 1 of 3

A – See Sheet 1 of 3