



SERVICE BULLETIN

Title: 19XL High Voltage Terminal Installation
Models Affected: 19XL

Number: C9504
Date: 1/11/95
Supersedes:
Date:

Situation:

Procedure for the assembly and installation of 19XL High Voltage Motor Terminals:

(See **Figure 1**)

To ensure a leaktight seal, the mating surfaces of the motor housing and the insulator must be clean, smooth, and lightly coated with O-ring lubricant.

File: Compressor, Motor, Drive, Gears

Prepared By: Don Berdan

Approved By: Alan Johnson

This document and the material contained herein are the property of Carrier Corporation and may not be copied, reproduced, or released without written permission of Carrier Corporation.

Procedure:

1. Inspect the terminal insulator in the bottom of the O-ring area. Smooth any sharp edges seen in this area with emery cloth or fine sandpaper. Lubricate the insulator threads lightly with O-ring lubricant.
2. Sufficient torque to seal the O-ring and preload the threads to prevent loosening is obtained by seating the insulator to the motor casting HAND TIGHT.

WARNING



WARNING

Under no circumstances should the insulator be tightened more than hand tight or more than 4 Ft-Lbs (5.4 Newton-meters) torque, as overtightening will not help to seal the terminal, and will cause breakage of the insulator material. Serious injury from refrigerant burns or asphyxiation could result if the terminal breaks with refrigerant in the machine, as well as causing machine damage due to freezing water within the cooler tubes.

3. Assemble the retainers, packing ring and packing nut. Tighten the packing nut to 5 ft-lbs. (6.8 Newton-meters) while holding holding the insulator across its flats. Do not overtighten, as this can lead to insulator weakening and failure.
4. Tighten the brass jam nut to 10 ft-lbs (13.5 Newton-meters) while holding the packing nut across its wrench flats with another open end wrench. Again, Do not overtighten.
5. If damage or leaking occurs during or after this procedure has been followed, the parts used are defective and should be replaced. The service engineering department should then be notified.

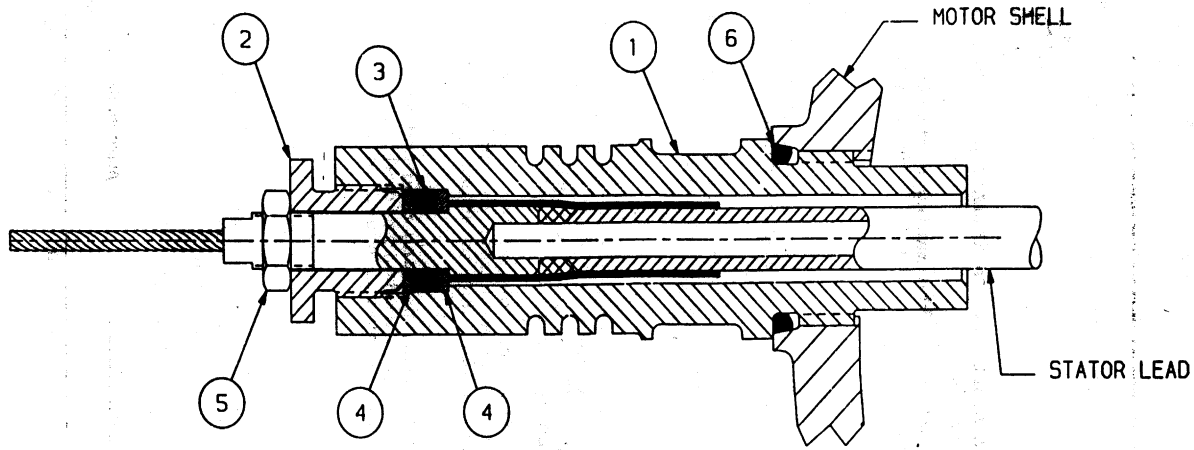

LEGEND:

- ITEM 1 - Terminal Insulator
- ITEM 2 - Packing Nut
- ITEM 3 - Packing Ring
- ITEM 4 - Terminal Retainer
- ITEM 5 - Jam Nut
- ITEM 6 - O-Ring

Figure 1 — 19XL High Voltage Terminal