



SERVICE BULLETIN

Title: Guide Vane Shaft Bearing/Seal Oil Cup
Models Affected: 17/19 DK, DM

Number: C9205
Date: 5/14/92
Supersedes:
Date:

Purpose:

This bulletin is to advise the field organization that after July 1992 a new guide vane shaft bearing/seal housing and oil cup will be implemented on all 17/19 DK, DM compressors.

File Instructions: Service–Parts

Prepared By: Otto Rosasco

Approved By: Alan Johnson

This document and the material contained herein are the property of Carrier Corporation and may not be copied, reproduced, or released without written permission of Carrier Corporation.

Background:

Recently the bearing/seal housing had a cap on the oil supply located at the 12 o'clock position of the housing. The cap held only a few drops of oil so regular maintenance was required.

Redesign Information:

The new shaft bearing/seal housing has a larger, clear oil cup that allows the operator to see the oil level at a glance. Although most items remain the same for the new housing assembly, below find a listing of the parts that are different:

(Refer to [Figure 1](#))

	New Part #	Old Part #
1 Guide vane shaft Assy.	19DM222-253	19DM212-253
2 Bearing housing*	19DM222-1093	19DM212-1093
3 Oil cap/cup	CW51EG603	CW51ZZ001

* O-Rings for both assemblies are the same, when retrofitting it is advised to change these elastomers.

See the unit's parts book for other parts.

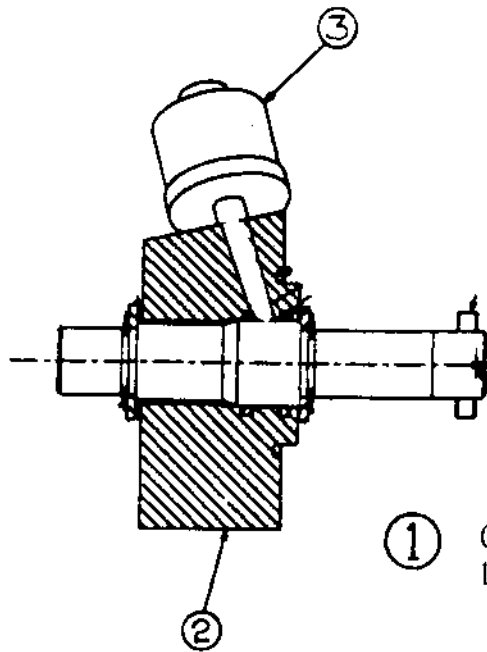

① Guide vane shaft assembly
19DM222-253

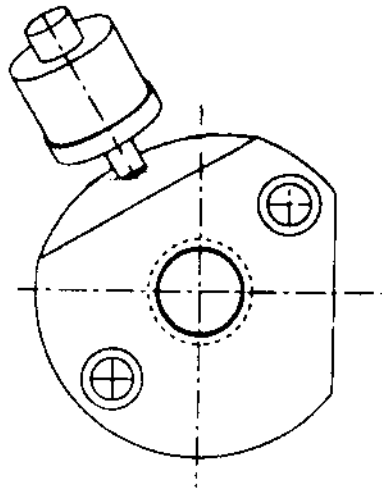

FIGURE 1.0