



**UNITED
TECHNOLOGIES
CARRIER**

Commercial Division
Carrier Corporation

BULLETIN: CA-SB-19-D-67-40
DATE: 10/19/67
PAGE: 1 OF: 5

SERVICE BULLETIN

SUBJECT:

19DA PURGE CONDENSING CHAMBER

SUPERSEDE
BULLETIN:
DATE:
PAGE: OF:

Installation, repair and service and equipment referenced in this Service Bulletin should be undertaken only by qualified persons. Carrier Corporation (1) makes no representations or warranties, expressed or implied, concerning the accuracy, completeness or right to use the information contained herein, and (2) disclaims all liability for injuries, damages, infringements and other losses which may arise on account of, or which may result from, the use or application of any information, method or apparatus disclosed herein.

PURPOSE

To supplement existing service information concerning the 19DA purge condensing chamber.

MACHINES AFFECTED

All 19DA machines.

PROCEDURE

The 19DA purge condensing chamber and purge float chamber are constructed as a single unit which is welded to the cooler section of the unishell. A portion of this unit actually extends into the cooler. Refer to Chapter 4 of the Operation and Maintenance Instructions (19DA-1SO, dated 1/67) for functional descriptions and pictorial views of this chamber.

Figure 1 shows a cutaway view of this chamber. Note that the condensing chamber is a sealed unit separated from the float chamber by a welded center plate. The condensing chamber contains a finned condensing coil. Liquid refrigerant flows through the coil and is discharged directly into the cooler. This coil cannot be removed for service.

The purge float chamber, however, is accessible for service through a cover plate which is held in place by a V-band clamp and sealed with an O-ring as shown in Fig. 3. The purge float valve assembly is mounted on the inside of the cover plate. The float chamber should be serviced as recommended on page 27 of the Operation and Maintenance Instructions, 19DA-1SO, dated 1/67.

NOTE: When replacing the float valve and cover assembly and reconnecting the refrigerant return line, care should be taken that the float is oriented in an upright position.



**UNITED
TECHNOLOGIES
CARRIER**

Commercial Division
Carrier Corporation

BULLETIN: CA-SB-19-D-67-40
DATE: 10/19/67
PAGE: 2 OF: 5

SERVICE BULLETIN

SUPERSEDE
BULLETIN:
DATE:
PAGE: OF:

A cross-section of the settling chamber is shown in Figure 2. Condensed liquid drains into this chamber; any water present will rise and be visible in the water sight glass. This glass and the refrigerant sight glass in the float chamber cover plate are the same items and are available through the Parts Center.



SERVICE BULLETIN

SUPERSEDE

BULLETIN:

DATE:

PAGE: OF:

Fig. 1. Cutaway View of 19DA Purge Condensing Chamber Assembly

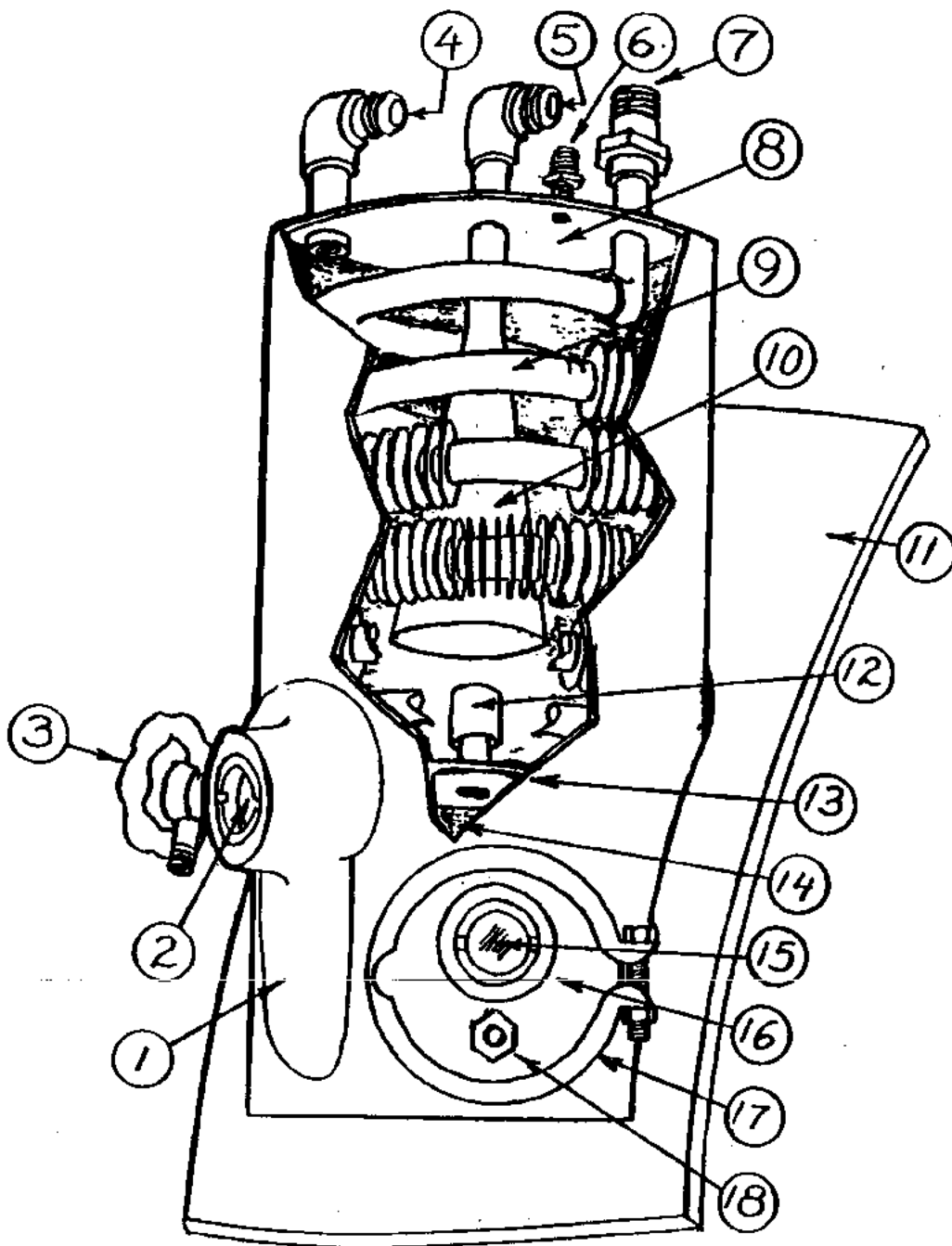



**UNITED
TECHNOLOGIES
CARRIER**

Commercial Division
Carrier Corporation

BULLETIN: CA-SB-19-D-67-40
DATE: 10/19/67
PAGE: 4 OF: 5

SERVICE BULLETIN

SUPERSEDE
BULLETIN:
DATE:
PAGE: OF:

1. Settling Chamber
2. Water Sight Glass
3. Water Drain Valve
4. Exhaust to Purge Pump
5. Intake from Purge Collection Chamber
6. Connection to Purge Pressure Gage and
Purge Operating Switch
7. Liquid Refrigerant Line Connection
8. Purge Condensing Chamber
9. Finned Condensing Coil
10. Cone
11. Mounting Plate (Welded to Cooler)
12. Vent
13. Welded Center Plate
14. Purge Float Chamber
15. Refrigerant Sight Glass
16. Float Chamber Cover Plate
17. V-Band Clamp
18. Refrigerant Return Tubing Connection



SERVICE BULLETIN

SUPERSEDE
BULLETIN:
DATE:
PAGE: OF:

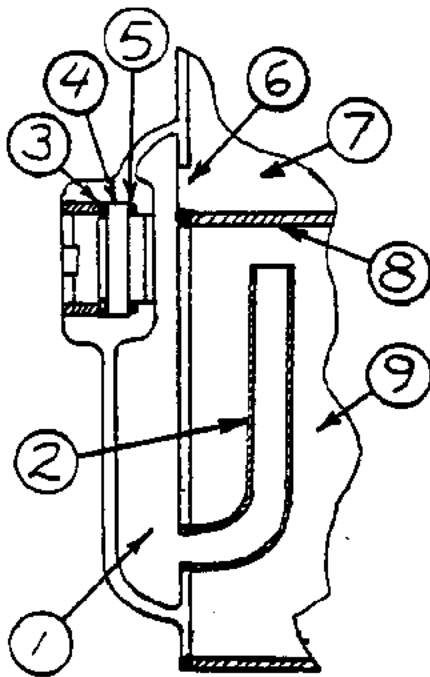

1. Settling Chamber
2. Refrigerant Return Elbow
3. Outer Sight Glass Gasket
4. Sight Glass
5. Inner Sight Glass Gasket
6. Condenser Drain Hole
7. Condensing Chamber
8. Center Plate
9. Float Chamber

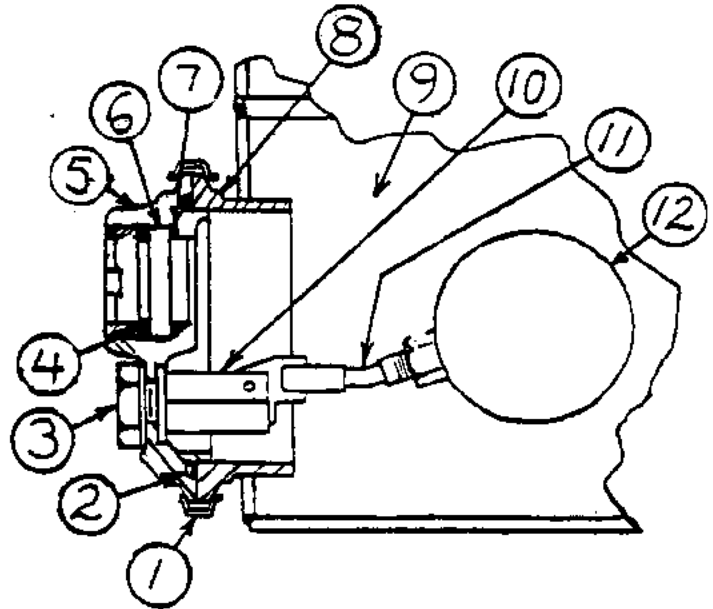

1. V-Band Clamp
2. O-Ring
3. Refrigerant Return Tubing Connection
4. Outer Sight Glass Gasket
5. Cover Plate
6. Sight Glass
7. Inner Sight Glass Gasket
8. Float Chamber Flange
9. Float Chamber
10. Valve and Seat Assembly
11. Float Arm
12. Float Ball

Fig. 2. Section Showing Water Sight Glass, Settling Chamber, and Refrigerant Return Elbow

Fig. 3. Section Showing Refrigerant Sight Glass, Float Chamber Cover, and Float Valve