



**UNITED
TECHNOLOGIES
CARRIER**

Commercial Division
Carrier Corporation

BULLETIN: CA-SB-19-C-67-33
DATE: 3/9/67
PAGE: 1 OF 5

SERVICE BULLETIN

SUBJECT:

MAIN BEARING THERMOSTAT

SUPERSEDE
BULLETIN:

DATE:
PAGE: OF:

Installation, repair and service and equipment referenced in this Service Bulletin should be undertaken only by qualified persons. Carrier Corporation (1) makes no representations or warranties, expressed or implied, concerning the accuracy, completeness or right to use the information contained herein, and (2) disclaims all liability for injuries, damages, infringements and other losses which may arise on account of, or which may result from, the use or application of any information, method or apparatus disclosed herein.

PURPOSE: To forward information concerning the newly designed main bearing potted thermostat and transmit instructions for installing this new thermostat to an existing machine in the field.

**MACHINES
AFFECTED:** All 1906, 7 and 8 (50 and 60 cycle) size compressors with serial number 41053 and higher.

**MATERIALS
REQUIRED:**

- 1) Thermostat (Part No. 19065-446), one required.
- 2) Insulated Wire Joint (Part No. HY89TBO09), two required.
- 3) Normal mechanics tools, plus wire cutting pliers and crimping tool.
- 4) 59/64" tap drill, 3/4" N.P.T. tap.

PROCEDURE: Background

The design of the main bearing thermostat has been changed. The present thermostat senses the temperature of the top surface of the main bearing cap. The new design, referred to as a "potted thermostat", senses the temperature of the oil within the bearing.



**UNITED
TECHNOLOGIES
CARRIER**

Commercial Division
Carrier Corporation

BULLETIN: CA-SB-19-C-67-33
DATE: 3/9/67
PAGE: 2 OF: 5

SERVICE BULLETIN

SUPERSEDE
BULLETIN:

DATE:
PAGE: OF:

The potted thermostat is designed to open at $180^{\circ}\text{F} \pm 8^{\circ}\text{F}$, and close again at $160^{\circ}\text{F} \pm 5^{\circ}\text{F}$.

The new thermostat can be installed in any existing 19C6, 7 and 8 compressor. However, machining is involved. It is not recommended unless the compressor has a history of bearing thermostat nuisance tripouts.

Installation

The following is a step-by-step guide to be used for installing the potted thermostat to an existing machine in the field.

I. Disassembly

- a) Disconnect electric power to machine by removing circuit breakers (mark the junction box so that power will not be applied inadvertently).
- b) Remove main bearing inspection cover.
- c) Remove existing bearing thermostat by:
 1. Snipping wires to existing thermostat within 2 inches of thermostat (Figure 1).
 2. Unscrew the two machine screws that hold thermostat to bearing cap and remove the thermostat (Figure 1).

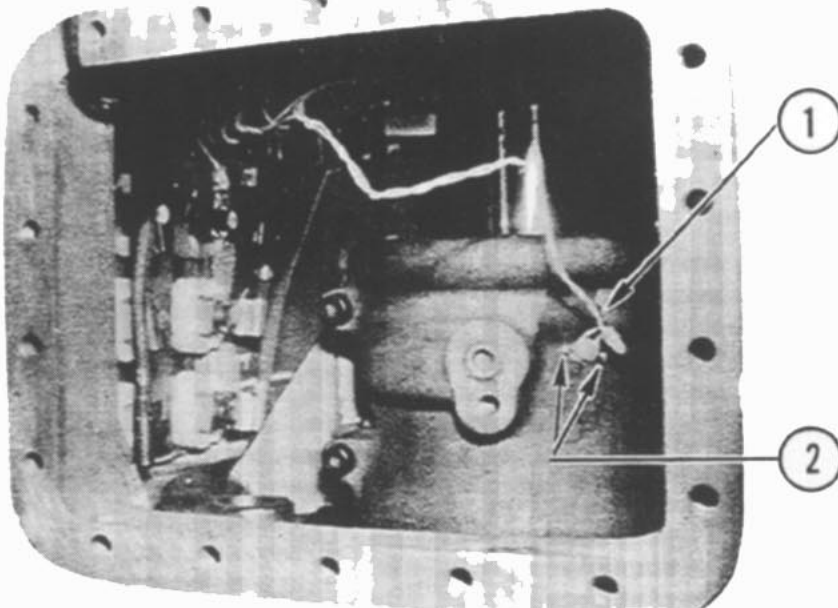

VIEW LOOKING THROUGH MAIN
BEARING INSPECTION COVER

1. Snip lead wires here. Strip back insulation 1/2 inch to provide for splicing.
2. Unscrew these two machine screws to remove existing thermostat.



**UNITED
TECHNOLOGIES
CARRIER**

Commercial Division
Carrier Corporation

BULLETIN: CA-SB-19-C-67-33
DATE: 3/9/67
PAGE: 3 OF: 5

SERVICE BULLETIN

SUPERSEDE
BULLETIN:
DATE:
PAGE: OF:

- d) Remove main bearing cap.
 - 1. Care must be taken to prevent any foreign matter from entering the bearing assembly while removing the bearing cap.
 - 2. After removal, an opportunity exists to inspect the main bearing.
 - 3. Cover the exposed assembly to prevent foreign matter from entering while the bearing cap is off.
- e) Wrap bearing cap sufficiently to prevent any damage occurring while transporting the cap to a machine shop.

II. Machining

- a) Figure 2 shows all pertinent measurements necessary to properly machine the bearing cap. The view shown is based on observing the bearing from the motor end. (NOTE - Figure 2 is not a scale drawing.)
- b) There are two critical measurements necessary to properly position the center of the hole to drill.
 - 1. The horizontal distance from the face of the bearing (motor end) to the centerline of the oil groove (nominally 2-1/4 inches).
 - 2. 22° left of top dead center (looking from motor end).

III. Re-Assembly

- a) Examine bearing cap after machining; remove any loose chips or filings which could fall into bearing assembly.
- b) Snip long wire on new thermostat so that both wires are equal in length.
- c) Install potted thermostat into bearing cap. Do not use thread sealing compound.
- d) Examine inside of bearing cap to insure proper fit of thermostat (sensing element should extend slightly below inside surface so it will be in direct contact with the oil).
- e) Install bearing cap in compressor.
- f) Splice lead wires to the thermostat using insulated wire joints. The insulation must be stripped back 1/2 inch on the wires to be spliced. Twist the ends together and insert them into the wire joint. Use a crimping tool to crimp the wire joint and wire ends, thereby providing a secure splice.



**UNITED
TECHNOLOGIES
CARRIER**

Commercial Division
Carrier Corporation

BULLETIN: CA-SB-19-C-67-33
DATE: 3/9/67
PAGE: 4 OF: 5

SERVICE BULLETIN

SUPERSEDE
BULLETIN:
DATE:
PAGE: OF:

- g) Replace main bearing inspection plate.
- h) Re-connect electric power to machine.

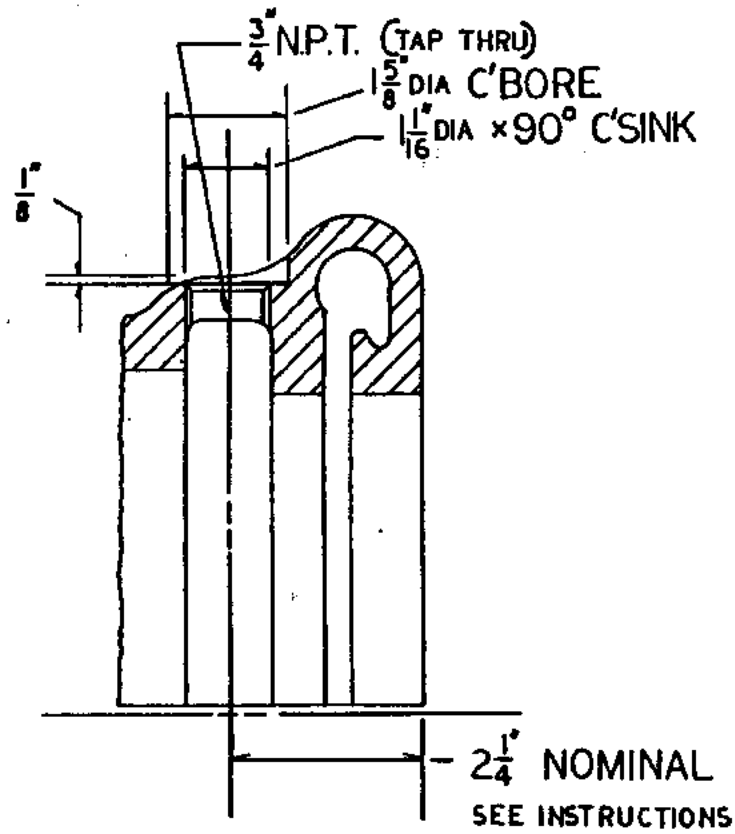
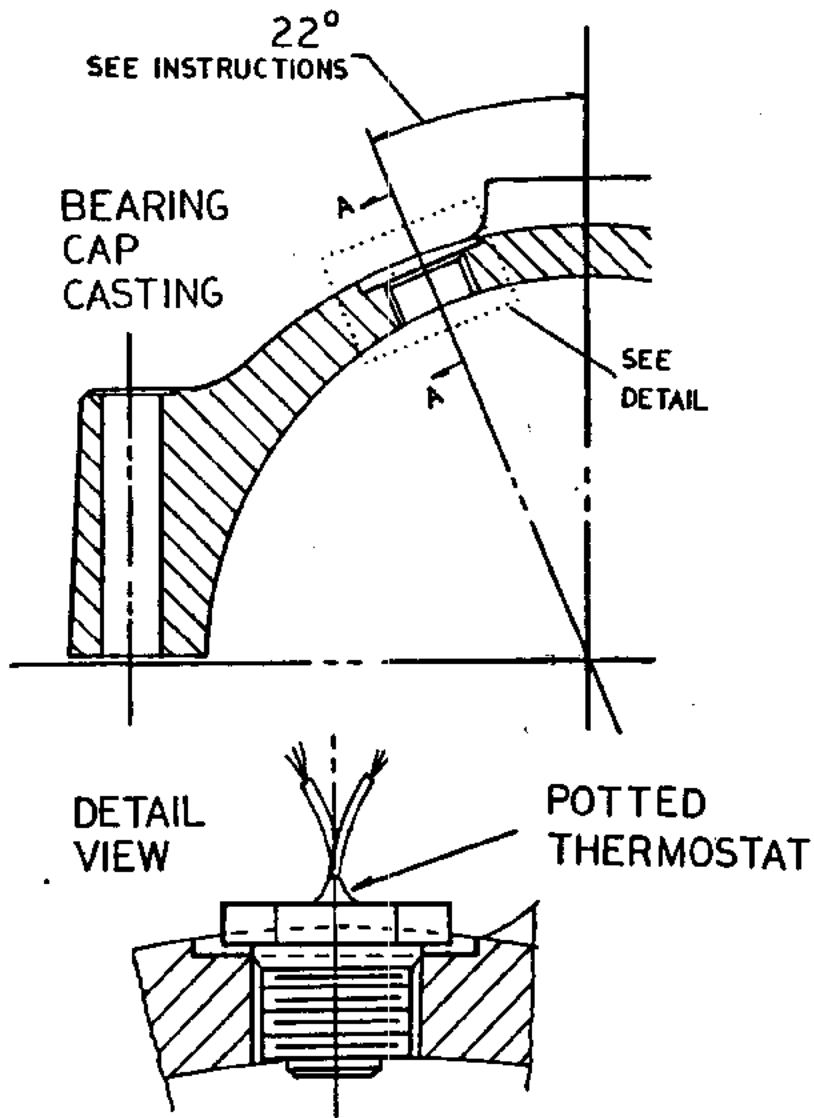

UNITED TECHNOLOGIES
CARRIER

Commercial Division
Carrier Corporation

SERVICE BULLETIN

BULLETIN: CA-SB-19-C-67-33
 DATE: 3/9/67
 PAGE: 5 OF: 5

SUPERSEDE BULLETIN:
 DATE:
 PAGE: OF:

FIGURE 2